

Quick guide

SILENO/SILENO+

R100Li/LiC, R130Li/LiC, R160Li/LiC



GETTING STARTED WITH THE GARDENA ROBOTIC LAWNMOWER

1. Placement of and connecting the charging station

See chapter 3.2 in the Operator's Manual

1. Place the charging station at a central position in the work area, with a lot of open space in front of the charging station and on a relatively horizontal surface.
2. Connect the power supply's low voltage cable to the charging station and the power supply.
3. Connect the power supply to a 100-240 V wall socket.

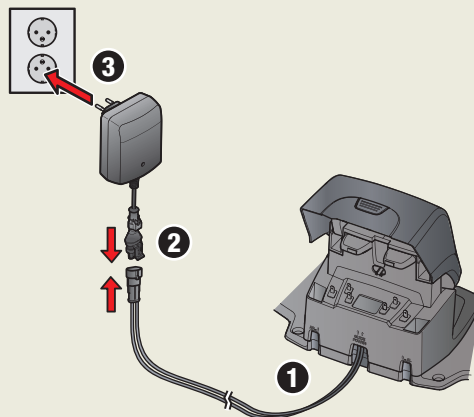

2. Charging the battery and placement of the boundary wire

See chapter 3.3 and 3.4 in the Operator's Manual

1. Place the robotic lawnmower in the charging station to charge the battery while the boundary wire is laid. Set the main switch to position 1.
2. Run the boundary wire ensuring it forms a loop around the work area.
3. Make an eyelet at the point where the guide wire will be connected later (see point 3.4).

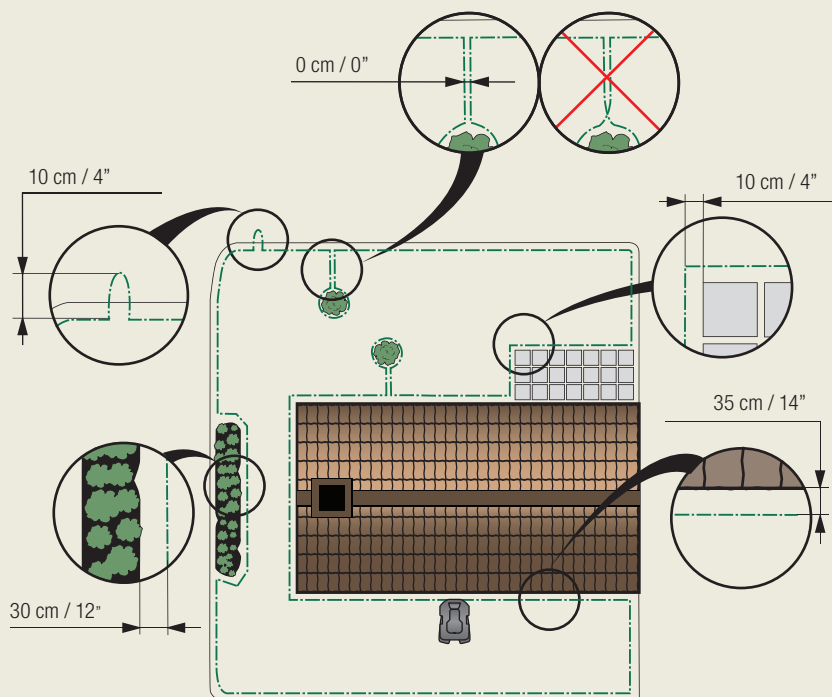

1. Main switch
2. STOP button
3. LED for function check of the boundary and guide wires
4. Display
5. Keypad



Charging station



3. Connecting the boundary wire

See chapter 3.5 in the Operator's Manual

1. Open the connector and lay the wire ends in the recesses on each connector.
2. Press the connectors together using a pair of pliers.
3. Cut off any surplus boundary wire. Cut 1 to 2 cm above the connectors.
4. Press the connectors onto the contact pins, marked AL (left) and AR (right), on the charging station. It is important that the right-hand wire is connected to the right-hand contact pin, and the left-hand wire to the left-hand pin.
5. Mark the wires with the accompanying cable markers. This makes it easier to reconnect the wires correctly.

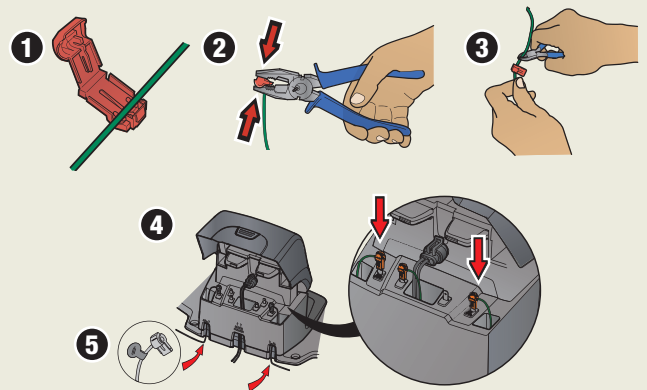

4. Placement of and connecting the guide wire

See chapter 3.6 in the Operator's Manual

1. Place the guide wire under the charging station, using any of the two guide channel positions marked with "GUIDE".
2. Fit the connector to the guide wire in the same way as for the boundary wire, according to the instructions above.
3. Fasten the connector to the contact pin marked G1 (guide) on the charging station.
4. Lay the guide wire at least 2 metres straight out from the front edge of the charging station.
5. Run the guide wire to the point on the boundary loop where the connection will be made. Avoid laying the wire at tight angles.
6. Cut the boundary wire with a wire cutters at the centre of the eyelet that was made in point 2.3.
7. Connect the guide wire to the boundary wire using the accompanying couplers. Press the couplers completely together with a pair of pliers.

„As a complement to this Quick Guide, there are step by step installation movies available on the GARDENA website, www.gardena.com.“

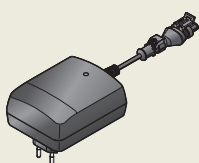
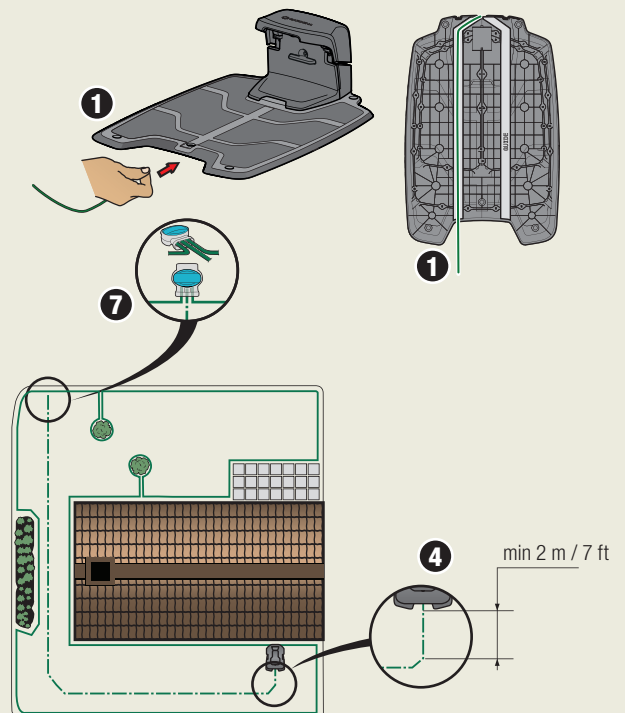

Power supply

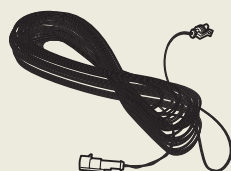

Low voltage cable

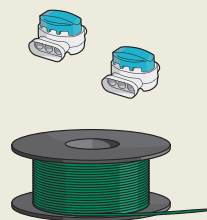

Boundary wire and couplers

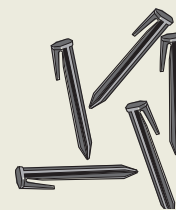

Pegs

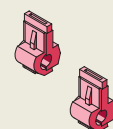

Connectors



Measurement gauge

5. Starting and stopping

See chapter 4.4 and 4.5 in the Operator's Manual

Starting

1. Open the cover by pressing the *STOP* button.
2. Set the main switch to position 1. When you do this for the first time, a start up sequence starts where you select a four digit PIN code among other things.
3. Press the *START* button.
4. Close the cover.

Stopping

Press the *STOP* button.



6. Adjust the robotic lawnmower to suit your garden

See chapter 6.3, 6.5, 6.7 and 6.8 in the Operator's Manual

Here you will find some tips on important settings for your robotic lawnmower. All settings for your robotic lawnmower are made via the menu functions.

Adjust the mower to suit the size of your lawn

The mowing results depend on mowing time. Adjust the mowing time to suit your garden using the *Timer* function. If the mower cuts too often, the lawn will appear trampled down. If the mower cuts too seldom, the lawn will not be properly mown.

Timer

You decide what times during the day and days of the week the mower is to work. When setting the timer, calculate that the robotic lawnmower mows about the listed amount of the number of square meters per hour and day listed in table Work capacity.

Table Work capacity

Model	About m ² per hour and day
GARDENA R100Li / R100LiC	59
GARDENA R130Li / R130LiC	68
GARDENA R160Li / R160LiC	70

Test run the mower through narrow passages

Narrow passages in the garden make it difficult for the mower to find the charging station. Use the *Test* function to test that the mower can travel through the narrowest passage.

1. Place the mower in the charging station.
2. Select *Test* in the robotic lawnmower's menu (Lawn coverage > Area X > More > Test) and press OK. Then press the **Start** button and close the cover.
3. Check that the mower follows the guide wire through the passage.
 - a. If the mower travels through the passage, the test is complete.
 - b. If the robotic lawnmower does not get through the passage: Check that the guide wire has been laid according to the instructions in chapter 3.6 in the Operator's Manual.

It is also possible to adjust the corridor width for the guide wire. See chapter 6.7 in the Operator's Manual.

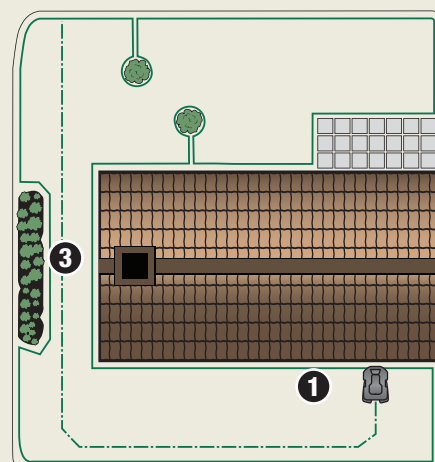

WWW.GARDENA.COM

 **GARDENA**[®]