



Operator's manual
HUSQVARNA AUTOMOWER®
310/315/315X



EN, English

Read the operator's manual carefully and make sure that you understand the instructions before you use the product.

Contents

1 Introduction

1.1 Introduction.....	3
1.2 Support.....	3
1.3 Product description.....	3
1.4 Finding the charging station.....	3
1.5 Product overview	4
1.6 Symbols on the product.....	5

2 Safety

2.1 Safety definitions.....	6
2.2 General safety instructions.....	6
2.3 Safety instructions for operation.....	6

3 Installation

3.1 Presentation.....	9
3.2 Preparations.....	9
3.3 Charging station.....	10
3.4 Charging the battery.....	12
3.5 Boundary wire.....	12
3.6 Connecting the boundary wire.....	17
3.7 Installation of the guide wire.....	17
3.8 Checking the installation.....	19
3.9 First start-up and calibration.....	19
3.10 Pairing with the Automower® Connect app.....	19
3.11 Automower® Connect menu.....	20
3.12 Connectivity.....	21
3.13 Test docking with the charging station.....	22
3.14 Control panel.....	22
3.15 Menu structure.....	23
3.16 Timer.....	24
3.17 Security.....	25
3.18 Messages.....	26
3.19 Weather timer.....	27
3.20 Installation.....	27
3.21 Settings.....	32
3.22 Accessories.....	34
3.23 Menu structure overview.....	37
3.24 Menu structure overview.....	38
3.25 Yard layout examples.....	39

4 Operation

4.1 Main switch.....	43
4.2 Start.....	43
4.3 Operating mode - Start.....	43
4.4 Operating mode Park.....	44
4.5 Stop.....	44
4.6 Switch off.....	44
4.7 Timer and Standby.....	44
4.8 Charge a flat battery.....	45
4.9 Adjust the cutting height.....	45

5 Maintenance

5.1 Introduction - maintenance.....	46
5.2 Clean the robotic lawnmower.....	46
5.3 Replace the blades.....	46
5.4 Battery.....	47
5.5 Winter service.....	47

6 Troubleshooting

6.1 Introduction - troubleshooting.....	48
6.2 Fault messages.....	48
6.3 Information messages.....	51
6.4 Indicator lamp in the charging station.....	52
6.5 Symptoms.....	52
6.6 Find breaks in the loop wire.....	53

7 Transportation, storage and disposal

7.1 Transportation.....	56
7.2 Storage.....	56
7.3 Disposal.....	56

8 Technical data

8.1 Technical data.....	57
-------------------------	----

9 Warranty

9.1 Guarantee terms.....	59
--------------------------	----

10 EC Declaration of Conformity

10.1 EC Declaration of Conformity.....	60
--	----

1 Introduction

1.1 Introduction

Serial number:

PIN code:

The serial number is on the product rating plate and on the product registration key.

- Use the product registration key and the serial number to register your product on www.husqvarna.com.

1.2 Support

For support about the Husqvarna product, speak to your servicing dealer.

1.3 Product description

Note: Husqvarna regularly updates the appearance and function of the products. Refer to *Support on page 3*.

The product is a robotic lawn mower. The product has a battery power source and cuts the grass automatically. Collection of grass is not necessary.

The operator selects the operation settings with the keys on the keypad.

The display shows the selected and possible operation settings, and the operation mode of the product.

The boundary wire and the guide wire controls the movement of the product within the working area.

1.4 Finding the charging station

The robotic lawnmower can be set to search for the charging station in up to 3 different ways. The robotic lawnmower automatically combines these 3 search methods to locate the charging station as fast as possible, but also to avoid as much tracks forming as possible.

Using the manual settings options, the 3 search methods can be combined to optimize the search for the shape of the garden in question, see *Installation on page 9*.

1.4.1 Search method 1 - Irregular

Irregular search method means that the robotic lawnmower operates irregularly until it gets close to the charging station.

The benefit with this search method is that there is no risk of tracks on the lawn from the robotic lawnmower. The disadvantage is that search times can be somewhat long.

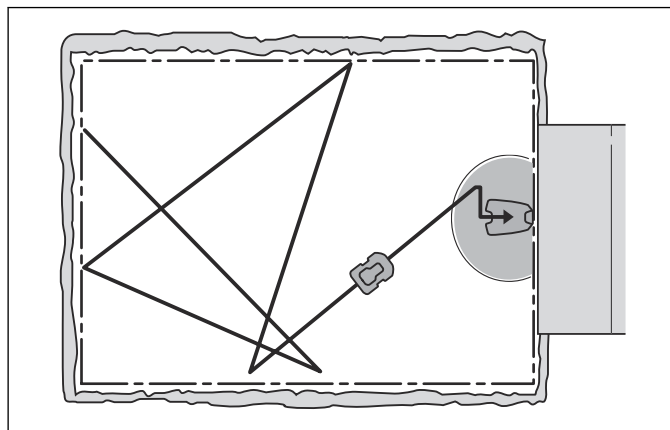

1.4.2 Search method 2 - Follow guide wire

Follow guide wire means that the robotic lawnmower operates irregularly until it reaches the guide wire. Then the robotic lawnmower follows the guide wire to the charging station.

The guide wire is a wire that is laid from the charging station towards, for instance, a remote part of the working area or through a narrow passage. The guide wire is then connected with the boundary loop. See *Installation of the guide wire on page 17*.

This search method makes it easier for the robotic lawnmower to find the charging station despite many or large islands, narrow passages or steep slopes.

The benefit of this search method is shorter search times.

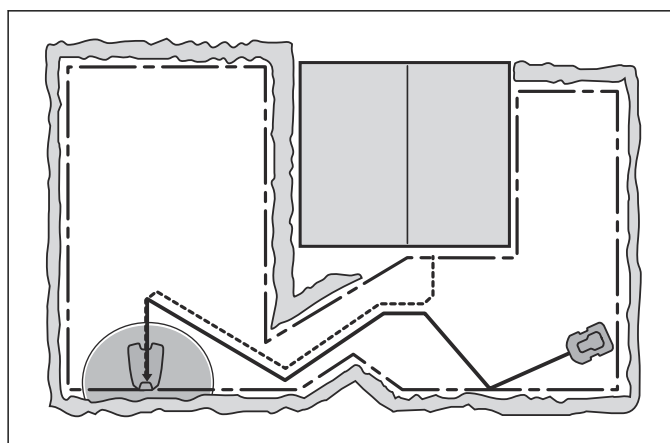

1.4.3 Search method 3 - Follow boundary wire

Follow boundary wire means that the robotic lawnmower operates irregularly until it reaches the boundary loop. Then it follows the boundary loop to the charging station. The robotic lawnmower randomly selects to travel clockwise or anticlockwise.

This search method is suitable in an installation with an open lawn space, wide passages (wider than about 3 m /10 ft.), and no or only a few small islands.

The benefit of this search method is that there is no need to install a guide wire.

The disadvantage is that some tracks can be formed alongside the boundary loop. The search time will also be longer if there are narrow passages or numerous islands in the installation.

As a rule, this search method is used only if the robotic lawnmower cannot find the charging station using search method 1 or 2 within the expected time period.

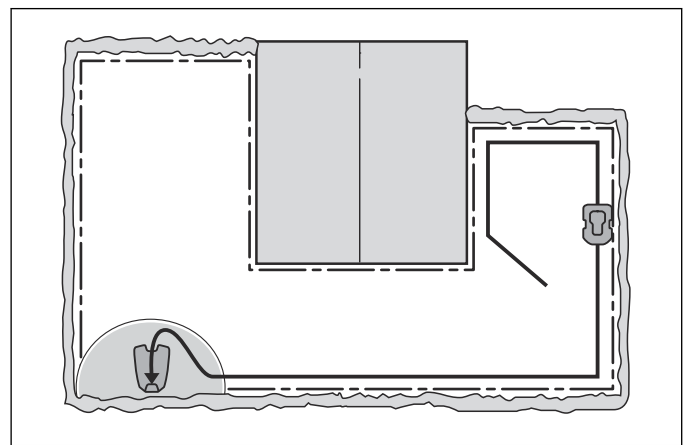

1.5 Product overview

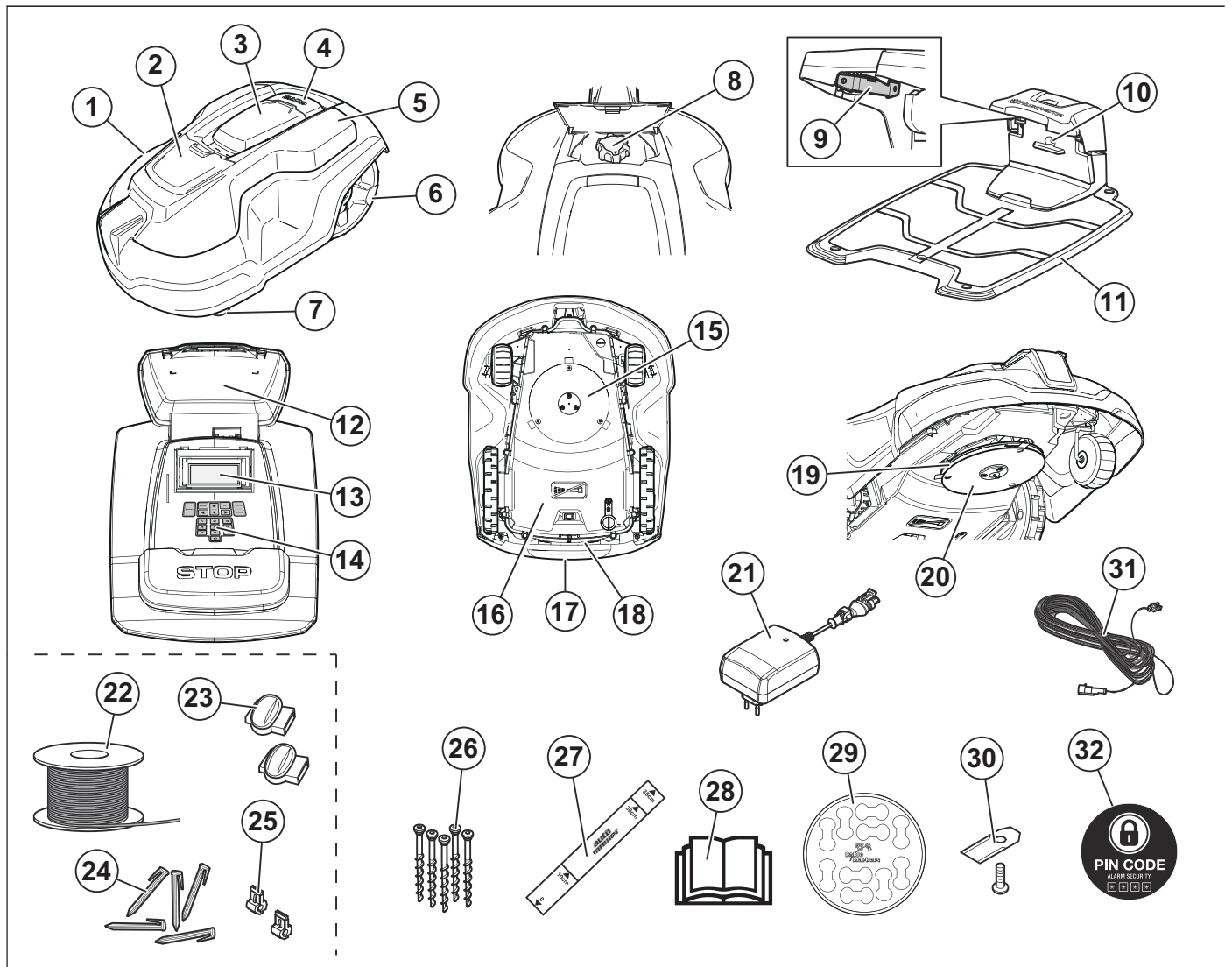

The numbers in the figure represent:

1. Body
2. Hatch to cutting height adjustment
3. Hatch to display and keypad
4. Stop button
5. Replaceable cover
6. Rear wheels
7. Front wheels
8. Cutting height adjustment
9. Contact strips

10. LED for operation check of the charging station and boundary wire
11. Charging station
12. Rating plate
13. Display
14. Keypad
15. Cutting system
16. Chassis box with electronics, battery and motors
17. Handle
18. Main switch
19. Blade disc

20. Skid plate
21. Power supply (the appearance of the power supply may differ depending on market)
22. Loop wire for boundary loop and guide wire ¹
23. Couplers for loop wire ²
24. Stakes³
25. Connector for the loop wire ⁴
26. Screws for securing the charging station
27. Measurement gauge for help when installing the boundary wire (the measurement gauge is broken loose from the box)
28. Operator's Manual and Quick Guide
29. Cable markers
30. Extra blades
31. Low voltage cable
32. Alarm decal



Noise emission to surroundings. The product's emissions are set out in *Technical data on page 57* and on the rating plate.



It is not permitted to dispose this product as normal household waste. Ensure that the product is recycled in accordance with local legal requirements.



The chassis contains components which are sensitive to electrostatic discharge (ESD). The chassis must also be resealed in a professional manner. For these reasons the chassis shall only be opened by authorized service technicians. A broken seal can result in the entire or parts of the guarantee no longer being valid.

1.6 Symbols on the product

These symbols can be found on the robotic lawnmower. Study them carefully.



WARNING: Read the user instructions before operating the robotic lawnmower.



WARNING: Operate the disabling device before working on or lifting the machine.

The robotic lawnmower can only start when the main switch is set to *1* and the correct PIN code has been entered. Turn the main switch to *0* before carrying out any inspections and/or maintenance.



The low voltage cable must not be shortened, extended or spliced.

Do not use a trimmer nearby the low voltage cable. Be careful when trimming edges where the cables are placed.

Operate the disabling device before you use or lift the product.



WARNING: Keep a safe distance from the machine when operating. Keep your hands and feet away from the rotating blades.



WARNING: Do not ride on the machine. Never put your hands or feet close to or under the machine.

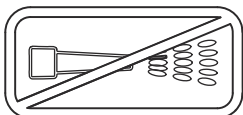

Never use a high-pressure washer or even running water to clean the robotic lawnmower.



This product conforms to the applicable EC Directives.

¹ Is a part of the Installation kit which is purchased separately.

² See note 1

³ See note 1

⁴ See note 1

2 Safety

2.1 Safety definitions

Warnings, cautions and notes are used to point out specially important parts of the manual.



WARNING: Used if there is a risk of injury or death for the operator or bystanders if the instructions in the manual are not obeyed.



CAUTION: Used if there is a risk of damage to the product, other materials or the adjacent area if the instructions in the manual are not obeyed.

Note: Used to give more information that is necessary in a given situation.

2.2.1 IMPORTANT. READ CAREFULLY BEFORE USE. KEEP FOR FUTURE REFERENCE

The operator is responsible for accidents or hazards occurring to other people or property.

This appliance is not intended for use by persons (including children) with reduced physical, sensory or mental capabilities, or lack of experience and knowledge, unless they have been given supervision or instruction concerning use of the appliance by a person responsible for their safety. Children should be supervised to ensure that they do not play with the appliance.

This appliance can be used by children aged from 8 years and above and persons with reduced physical, sensory or mental capabilities or lack of experience and knowledge if they have been given supervision or instruction concerning use of the appliance in a safe way and understand the hazards involved. Local regulations may restrict the age of the operator. Clearing and maintenance shall not be made by children without supervision.

Never connect the power supply to an outlet if plug or cord is damaged. Worn or damaged cord increase the risk of electric shock.

Only charge the battery in the included charging station. Incorrect use may result in electric shock, overheating or leaking of corrosive liquid from the battery. In the event of leakage of electrolyte flush with water/neutralizing agent, seek medical help if it comes in contact with the eyes.

Use only original batteries recommended by the manufacturer. Product safety cannot be guaranteed with other than original batteries. Do not use non-rechargeable batteries.

The appliance must be disconnected from the supply mains when removing the battery.



WARNING: The robotic lawnmower can be dangerous if used incorrectly.



WARNING: Never use the robotic lawnmower when persons, especially children or pets, are in the cutting area.



WARNING: Keep your hands and feet away from the rotating blades. Never put your hands or feet close to or under the machine when the motor is running.

2.2 General safety instructions

The following system is used in the Operator's Manual to make it easier to use:

- Text written in *italics* is a text that is shown on the robotic lawnmower's display or is a reference to another section in the Operator's Manual.
- Text written in **bold** is one of the buttons on the robotic lawnmower's keypad.
- Text written in *UPPERCASE* and *italics* refer to the different operating modes available in the robotic lawnmower.

2.3 Safety instructions for operation

2.3.1 Use

- This robotic lawnmower is designed to mow grass in open and level ground areas. It may only be used with the equipment recommended by the manufacturer. All other types of use are incorrect. The manufacturer's instructions with regard to operation/maintenance must be followed precisely.
- Warning signs shall be placed around the working area of the robotic lawnmower if it is used in public areas. The signs shall have the following text:
Warning! Automatic lawnmower! Keep away from the machine! Supervise children!

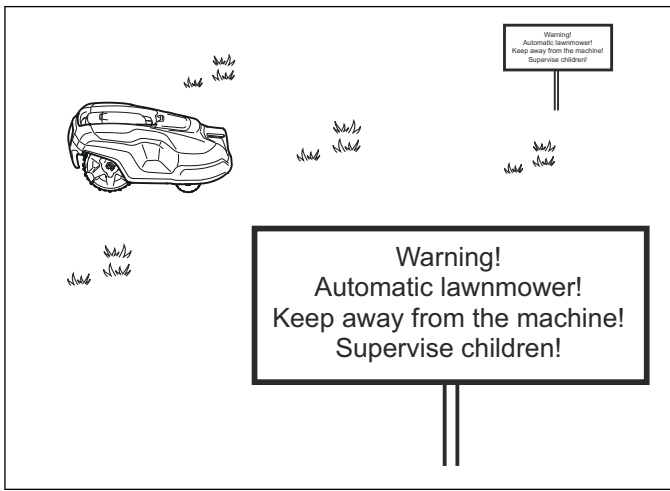

- Use the **PARK** function or switch off the main switch when persons, especially children or pets, are in the cutting area. It is recommended to program the lawnmower for use during hours when the area is free from activity, e.g. at night. See *Timer on page 24*.
- The robotic lawnmower may only be operated, maintained and repaired by persons that are fully conversant with its special characteristics and safety regulations. Please read the Operator's Manual carefully and make sure you understand the instructions before using the robotic lawnmower.
- It is not permitted to modify the original design of the robotic lawnmower. All modifications are made at your own risk.
- Check that there are no stones, branches, tools, toys or other objects on the lawn that can damage the blades. Objects on the lawn can also lead to the robotic lawnmower getting stuck in them and help may be required to remove the object before the mower can continue mowing. Always set the main switch in position 0 before clearing a blockage.

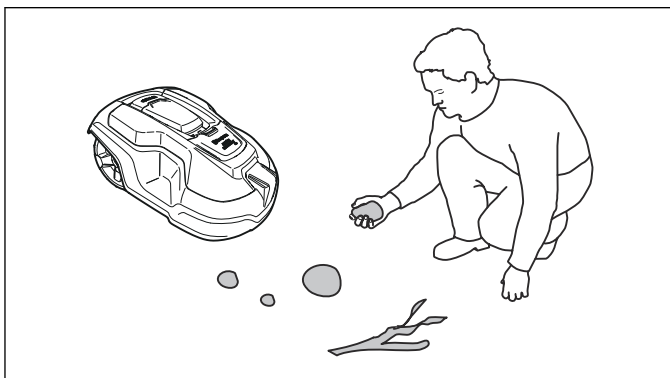

- Start the robotic lawnmower according to the instructions. When the main switch is set to 1; make sure to keep your hands and feet away from the rotating blades. Never put your hands and feet under the robotic lawnmower.
- Never touch moving hazardous parts, such as the blade disc, before it has come to a complete stop.
- Never lift up the robotic lawnmower or carry it around when the main switch is in position 1.
- Do not let persons who do not know how the robotic lawnmower works and behaves use it.

- The robotic lawnmower must never be allowed to collide with persons or other living creatures. If a person or other living creature comes in the lawnmower's way it shall be stopped immediately. See *Stop on page 44*.
- Do not put anything on top of the robotic lawnmower or its charging station.
- Do not allow the robotic lawnmower to be used with a defective guard, blade disc or body. Neither should it be used with defective blades, screws, nuts or cables. Never connect a damaged cable, or touch a damaged cable before it is disconnected from the supply.
- Do not use the robotic lawnmower if the main switch does not work.
- Always switch off the robotic lawnmower using the main switch when the robotic lawnmower is not in use. The robotic lawnmower can only start when the main switch is set to 1 and the correct PIN code has been entered.
- The robotic lawnmower must never be used at the same time as a sprinkler. Use the timer function (see *Timer on page 24*) so the mower and sprinkler never run simultaneously.
- Husqvarna does not guarantee full compatibility between the robotic lawnmower and other types of wireless systems such as remote controls, radio transmitters, hearing loops, underground electric animal fencing or similar.
- The built-in alarm is very loud. Be careful, especially if the robotic lawnmower is handled indoors.
- Metal objects in the ground (for example reinforced concrete or anti-mole nets) can result in a stoppage. The metal objects can cause interference with the loop signal which then can lead to a stoppage.
- The robotic lawnmower must never be stored, operated or charged in temperatures below 0 °C / 32 °F or above 45 °C / 113 °F. This might cause damage to the product.

2.3.2 How to lift and move the robotic lawnmower

To safely move from or within the working area:

1. Press the **STOP** button to stop the robotic lawnmower. If security is set to the medium or high level (see *Security on page 25*) the PIN code has to be entered. The PIN code contains four digits and is selected when you start the robotic lawnmower for the first time. See *First start-up and calibration on page 19*.

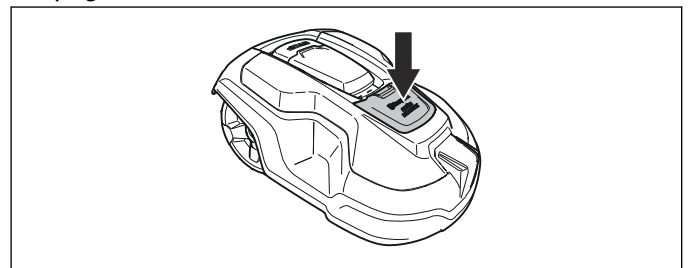

2. Set the main switch in position 0.

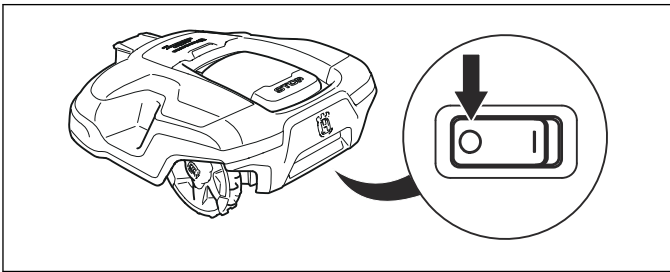

3. Carry the robotic lawnmower by the handle under the robotic lawnmower with the blade disc away from the body.

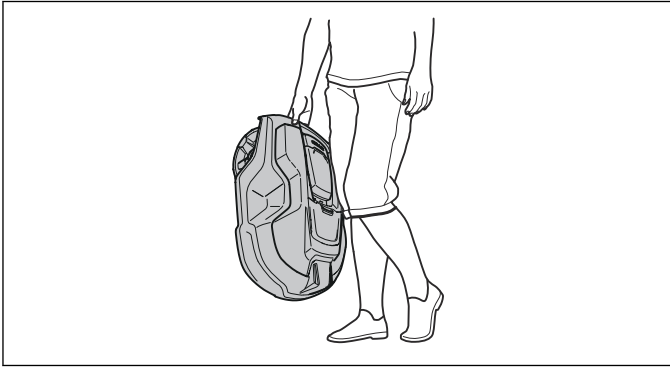

CAUTION: Do not lift the robotic lawnmower when it is parked in the charging station. It can damage the charging station and/or the robotic lawnmower. Press **STOP** and pull the robotic lawnmower out of the charging station before lifting it.

2.3.3 Maintenance



WARNING: When the robotic lawnmower is turned upside down the main switch must always be in the 0 position.

The main switch should be set in the 0 position during all work on the mower's chassis, such as cleaning or replacing the blades.

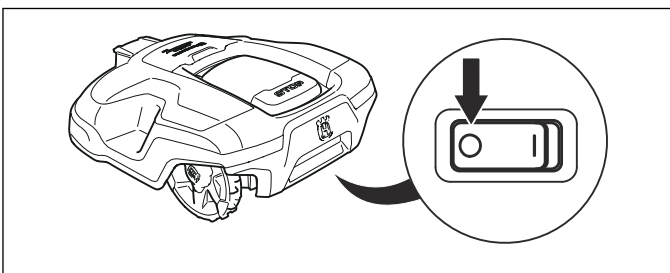

CAUTION: Never use a high-pressure washer or even running water to clean the robotic lawnmower. Never use solvents for cleaning.

Inspect the robotic lawnmower each week and replace any damaged or worn parts. See *Introduction - maintenance* on page 46.

2.3.4 In the event of a thunderstorm

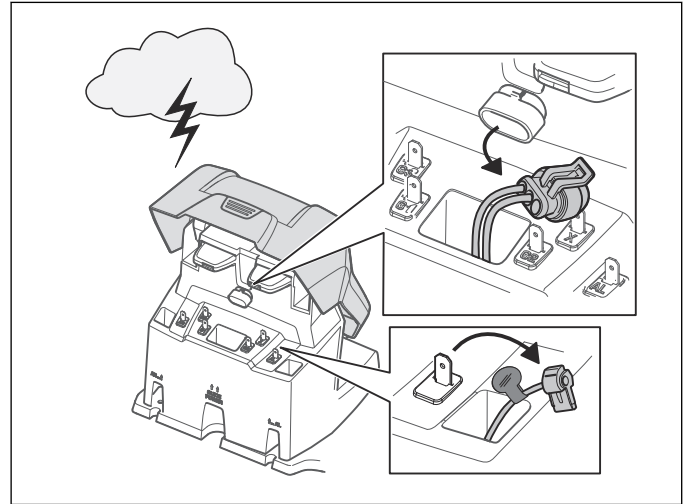

To reduce the risk of damage to electrical components in the robotic lawnmower and its charging station, we recommend that all connections to the charging station are disconnected (power supply, boundary wire and guide wires) if there is a risk of a thunderstorm.

1. Make sure the wires are marked with the supplied markers to simplify reconnecting. The charging station's connections are marked AR, AL and G1.
2. Disconnect all connected wires and the power supply.
3. Connect all the wires and the power supply if there is no longer a risk of thunder. It is important that each wire is connected to the right place.

3 Installation

3.1 Presentation

This chapter contains information that is important to be aware of when planning the installation.

Before starting the installation make yourself familiar with what is included in the carton.

Automower® 310/315/315X	
Robotic lawnmower	✓
Charging station	✓
Power supply	✓
Low voltage cable	✓
Charging station screws	5 pcs
Allen key	✓
Measurement gauge	✓
Cable markers	✓
Operator's manual and Quick guide	✓
Extra blades	9 pcs
Alarm decal	✓

3.1.1 Main components for installation

The installation of the robotic lawnmower involves 4 main components:

1. A robotic lawnmower that mows the lawn by essentially operating in a random pattern.

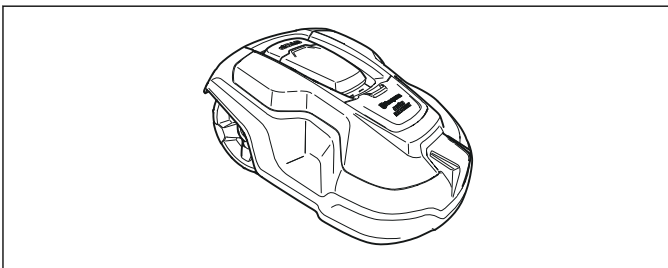

2. A charging station, to where the robotic lawnmower returns when the battery level becomes too low.

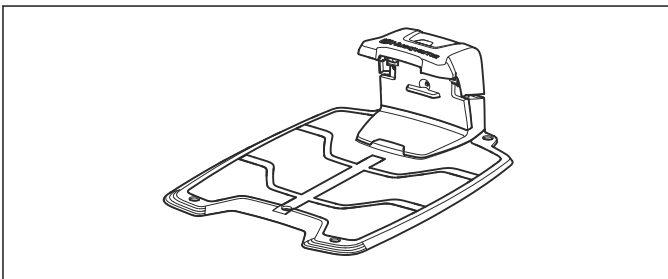

3. A power supply, which is connected to the charging station and a 100-240V wall socket. The power supply is connected to the wall socket and to the charging station using a 10 m / 33 ft. long low voltage cable. Low voltage cables with 3 m / 10 ft. and 20 m / 66 ft. length are available as optional accessories. No parts of the power supply must be

changed or tampered with. For example, the low voltage cable must not be shortened or extended.

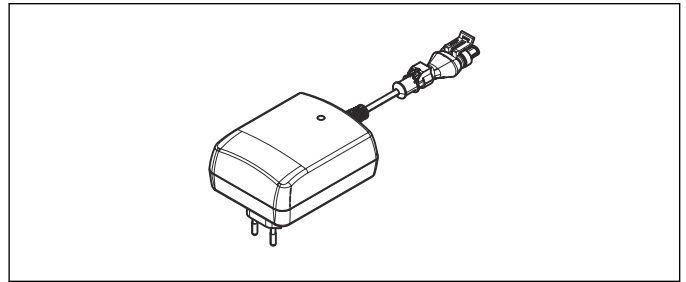

4. Loop wire, which is laid around the edges of the lawn and around objects and plants that the robotic lawnmower must not run into. The loop wire is used both as a boundary wire and a guide wire. The maximum permitted length for the boundary loop is 800 m / yd.

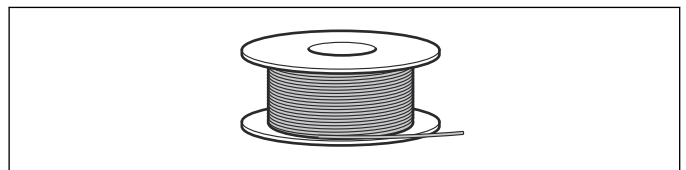

3.2 Preparations

Read through this entire chapter before beginning the installation. How the installation is done affects how well the robotic lawnmower works. It is therefore important to plan the installation carefully.

Planning is simplified if you make a sketch of the working area, including all obstacles. This makes it easier to see the ideal positions for the charging station, the boundary wire and the guide wire. Draw on the sketch where the boundary and guide wires should be routed.

Visit www.husqvarna.com for further descriptions and tips regarding installation.

1. If the lawn in the working area is longer than 10 cm / 4 in. mow it using a standard lawnmower. Collect the grass.
2. Fill in holes and hollows to stop rainwater from forming pools of water. The product may be damaged if it operates in pools of water. See *Guarantee terms on page 59*.

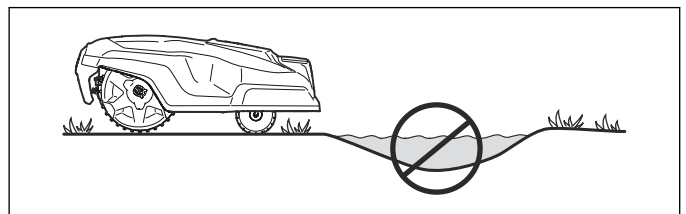

3. Read carefully through all the steps before the installation.
4. Check that all parts for the installation are included. See *Main components for installation on page 9*.
 - Robotic lawnmower
 - Charging station

- Power supply
- Low voltage cable
- Screws for the charging station
- Measurement gauge

3.2.1 Installation tools

During installation you will also need:

- Hammer/plastic mallet (to simplify putting the pegs in the ground).
- Combination pliers for cutting the boundary wire and pressing the connectors together.
- Multigrip pliers (for pressing the couplers together).
- Edge cutter/straight spade if the boundary wire is to be buried.

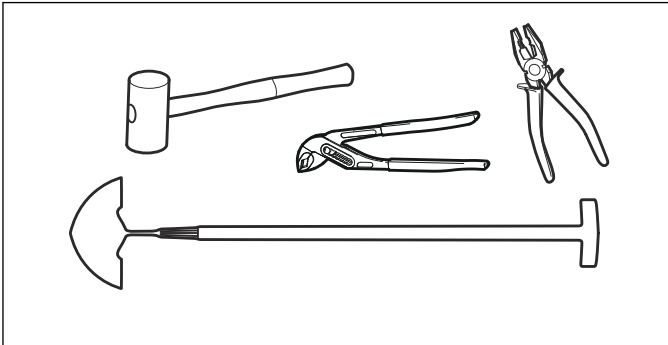

3.3 Charging station

The charging station has 3 functions:

- To send control signals along the boundary wire.
- To send control signals in the guide wire so that the robotic lawnmower can find the charging station.
- To charge the robotic lawnmower battery.

3.3.1 Best charging station location

Consider the following recommendations when identifying the best location for the charging station:

- Allow minimum 3 m / 10 ft. of free space in front of the charging station.
- Lay minimum 1.5 m / 5 ft. of boundary wire straight out to the right and left of the charging station.
- Place the charging station close to a wall socket. The supplied low voltage cable is 10 m / ft. long.
- Place the charging station on a level surface free from sharp objects.
- Protect the charging station from water spray, for instance from irrigation.
- Protect the charging station from direct sunlight. The charging process is affected by the ambient temperature.
- Place the charging station in the lower part of a working area that has a major slope.
- Consider if the charging station should be placed out of sight for outsiders.

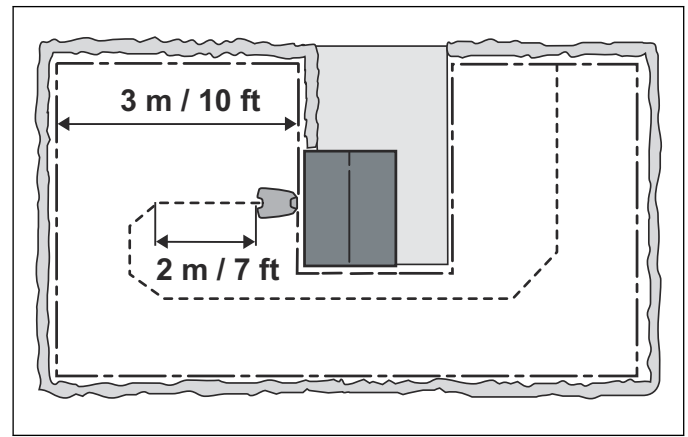

Avoid putting the charging station in confined spaces or in a corner. This can make it difficult for the robotic mower to find the charging station.



The charging station must be positioned on level ground. The front end of the charging station cannot be positioned higher or lower than the back end according to picture below.

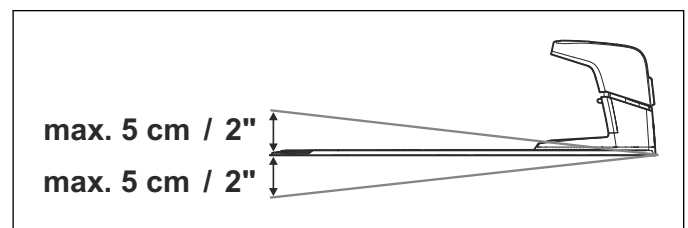

The charging station must not be positioned in a way that can bend its base plate.

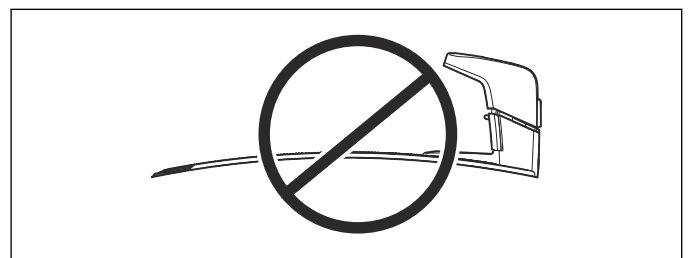

If the installation is done in a working area with a steep slope, the charging station should be placed at the bottom of the slope. This makes it easier for the robotic lawnmower to follow the guide wire to the charging station.

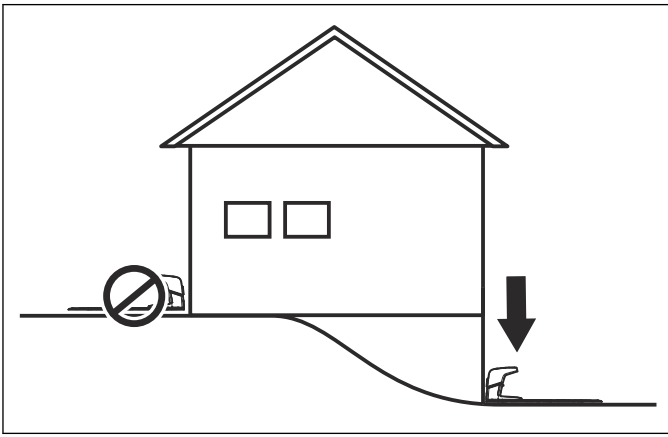

The charging station should not be placed on an island as this limits the laying of the guide wire in an optimal way. However, if the charging station has to be installed on an island, the guide wire also has to be connected to the island. Read more about islands in the *Boundaries within the working area* on page 14.

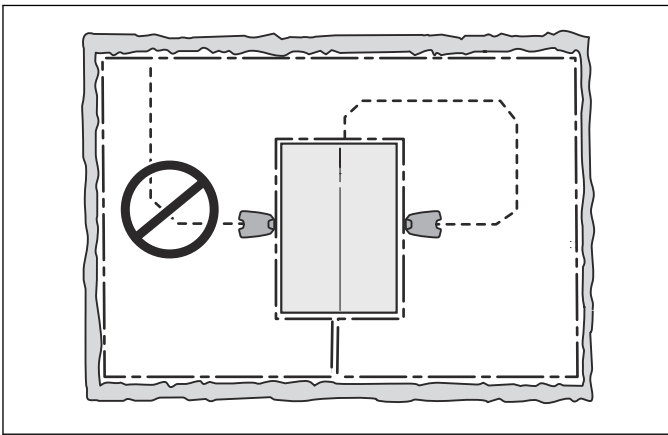

3.3.2 Connecting the power supply

Consider the following when planning where to place the power supply:

- Close to the charging station
- Protection from rain
- Protection from direct sunlight

The power supply must be placed where it is well ventilated and must be placed under a roof. If the power supply is connected to an electrical socket outdoors, this must be approved for outdoor use. It is recommended to use an earth fault-breaker (RCD) when connecting the power supply to the wall socket.



WARNING: Applicable to USA/Canada. If power supply is installed outdoors: Risk of electric shock. Install only to a covered Class A GFCI receptacle (RCD) that has an enclosure that is weatherproof with the attachment plug cap inserted or removed.

No parts of the power supply must be changed or tampered with. For example the low voltage cable must not be shortened or extended. Low voltage cables with 3 m or 20 m length are available as optional accessories.

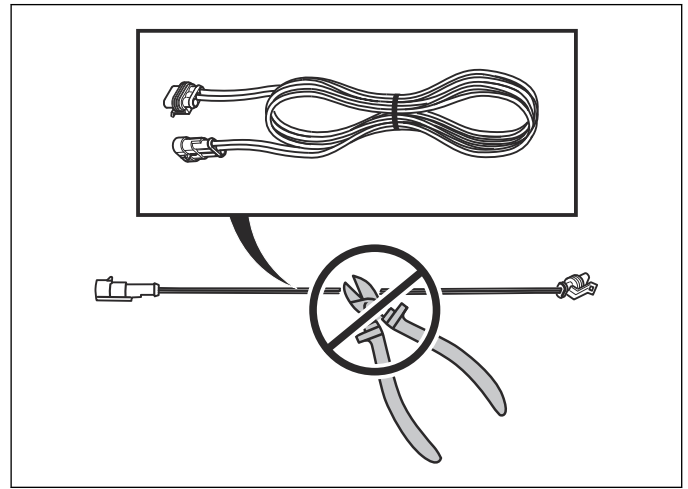

It is possible to let the low voltage cable cross the working area if it is stapled down or buried. The cutting height should be such that the blades can never come in contact with the low voltage cable.

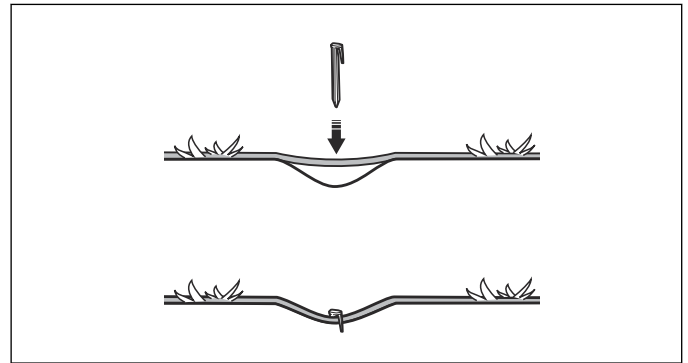

The low voltage cable must never be stored in a coil or under the charging station's base plate as this can interfere with the signals from the charging station.

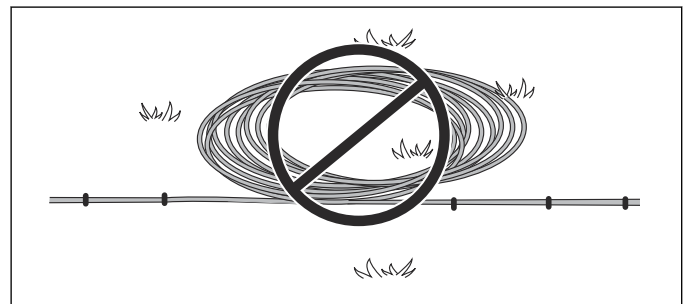

WARNING: Do not under any circumstances mount the power supply at a height where there is a risk it can be submerged in water (minimum 30 cm from the ground). It is not permitted to place the power supply on the ground.

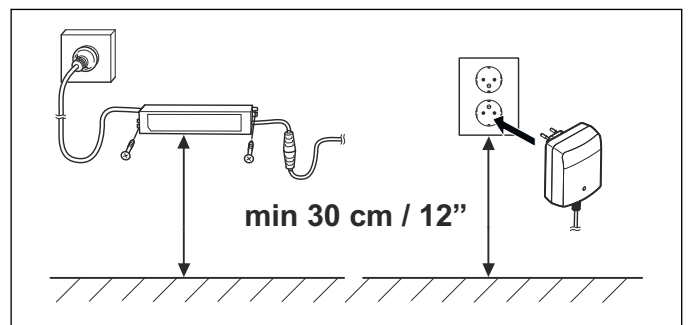

The appearance of the power supply may differ depending on the market.



WARNING: No parts of the power supply must under any circumstances be changed or tampered with. The low voltage cable must not be shortened or extended.



WARNING: Use the plug to disconnect the charging station, for instance before cleaning the charging station or repairing the loop wire.



CAUTION: Place the low voltage cable and adjust the cutting height so that the blades can never come in contact with it.

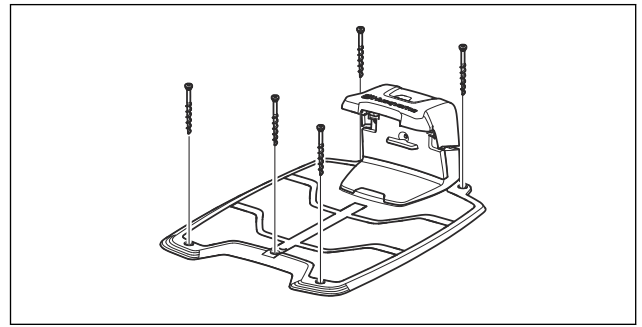

CAUTION: It is not permitted to make new holes in the charging station's plate. Only the existing holes may be used to secure it to the ground.



CAUTION: Do not tread or walk on the charging station's plate.



3.3.3 Installing and connecting the charging station

1. Position the charging station in a suitable spot. See *Best charging station location on page 10*.
2. Tilt the protective cover on the charging station forward and connect the low voltage cable to the charging station.

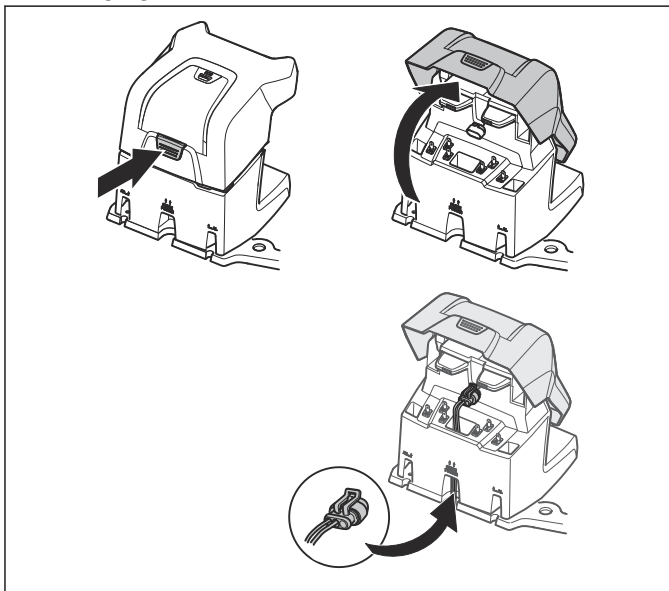

3. Connect the power supply's power cable to a 100-240V wall socket. If the power supply is connected to an electrical socket outdoors, this must be approved for outdoor use. See *Connecting the power supply on page 11*.
4. Attach the charging station to the ground using the supplied screws. Ensure the screws are screwed all the way down in the countersink.

Note: The guide wire must be laid and connected to the charging station before securing the charging station to the ground. See *Laying and connecting the guide wire on page 18*.

3.4 Charging the battery

When the charging station is connected, it is possible to charge the robotic lawnmower. Set the main switch to position 1.

Place the robotic lawnmower in the charging station while the boundary and guide wires are being laid.

If the battery is flat, it takes about 80 to 100 minutes to fully charge it.



WARNING: Only charge the robotic lawnmower using a charging station which is intended for it. Incorrect use may result in electric shock, overheating or leakage of corrosive liquid from the battery. In the event of leakage of electrolyte flush with water and seek medical help if it comes in contact with the eyes etc.

Note: The robotic lawnmower cannot be used before the installation is complete.

3.5 Boundary wire

The boundary wire can be installed in the following ways:

- Secure the wire to the ground with pegs.

Staple down the boundary wire if you want to make adjustments to the boundary loop during the first few weeks of operation. After a few weeks the grass will have grown over the wire making it no longer visible. Use a hammer/plastic mallet and pegs.

- Bury the wire.

Bury the boundary wire if you want to dethatch or aerate the lawn. If necessary, both methods can be combined so one part of the boundary wire is stapled down and the other is buried. The wire can be buried for instance using an edge cutter or a straight spade. Make sure to lay the boundary wire at least 1 cm and a maximum of 20 cm in the ground.

3.5.1 Plan where to lay the boundary wire

The boundary wire must be laid so that:

- The wire forms a loop around the working area. Use original boundary wire. It is specially designed to resist dampness from the soil.
- The robotic lawnmower is never more than 35 m / ft. from the wire at any point in the working area.
- The wire is no more than 800 m / ft. long.
- About 20 cm / 8 in. of extra wire is available to which the guide wire will be connected later. See *Laying the boundary wire on page 16*.

The illustration below shows how the boundary wire must be laid around the working area and around obstacles. Use the supplied measurement gauge to obtain the correct distance. See *Product overview on page 4*.

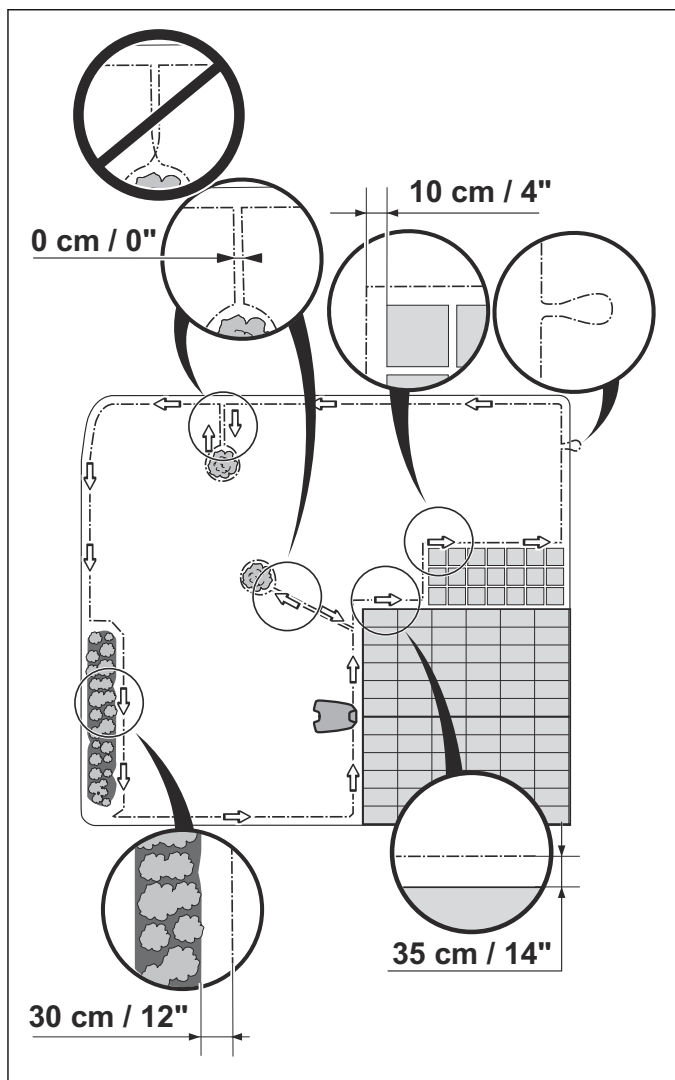

3.5.2 Working area boundaries

Depending on what the working area is adjacent to, the boundary wire must be laid at different distances from obstacles.

If a high obstacle (5 cm / 2 in. or more), for example a wall or fence, borders the working area, the boundary wire should be laid 35 cm / 14 in. from the obstacle. This will prevent the robotic lawnmower from colliding with the obstacle and reduce body wear. About 20 cm / 8 in. of the lawn around the fixed obstacle will not be mown.

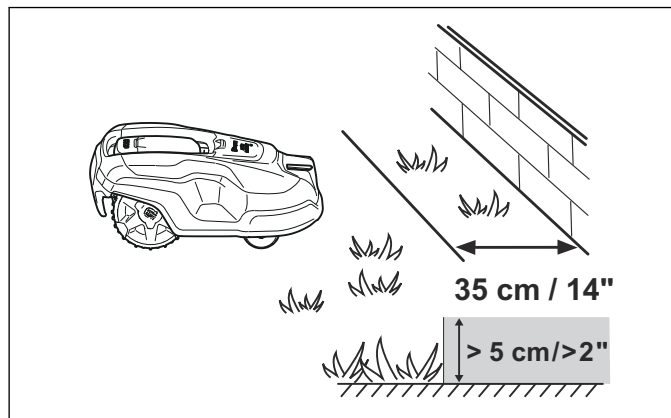

If the working area borders a small ditch, a flower bed or a small elevation, for example a low kerbstone (1-5 cm / 0.4-2 in.), the boundary wire should be laid 30 cm / 12 in. inside the working area. This prevents the wheels from driving into the ditch or up onto the kerbstone, which might lead to excessive wear on the robotic lawnmower. About 15 cm / 6 in. of the lawn along the ditch/kerbstone will not be mown.

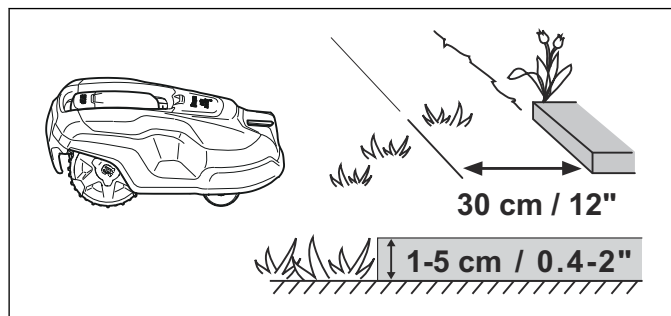

If the working area borders on a paving stone path or similar that is level with the lawn (+/- 1 cm / 0.4 in.), it is possible to allow the robotic lawnmower to run a little over the path. The boundary wire should then be laid 10 cm / 4 in. from the edge of the path. All the grass along the side of the paving stone path will be cut.

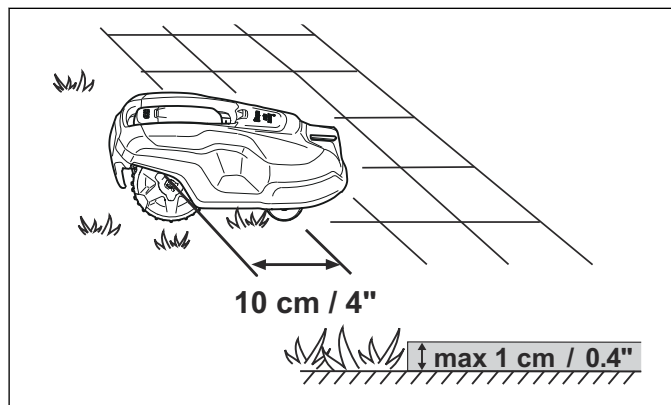

When the working area is divided by a paving stone path that is level with the lawn, it is possible to allow the robotic lawnmower to run over the path. It can be an advantage to lay the boundary wire under the paving stones. The boundary wire can also be laid in the joint between the paving stones. Ensure that the tiles are in level with the lawn to avoid excessive wear on the robotic lawnmower.

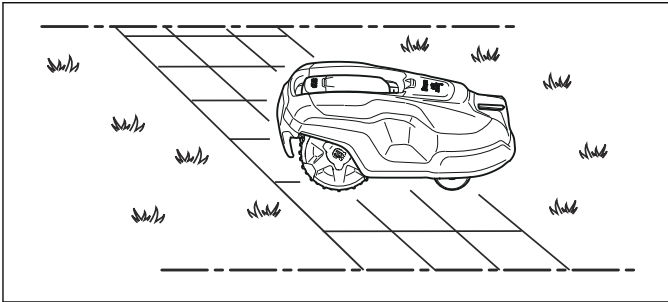

CAUTION: The robotic lawnmower must never run over gravel, mulch or similar material which can damage the blades.

CAUTION: If the working area is adjacent to water bodies, slopes, precipices or a public road, the boundary wire must be supplemented with an edging or the like. It must then be at least 15 cm / 6 in. in height. This will prevent the robotic lawnmower from ending up outside the working area under any circumstance.

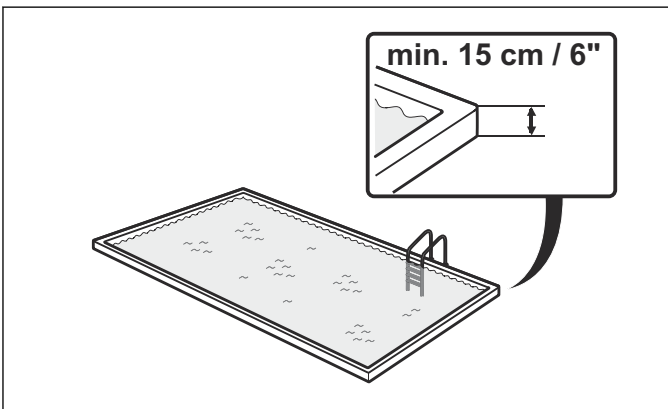

3.5.3 Boundaries within the working area

Use the boundary wire to isolate areas inside the working area by creating islands around obstacles which cannot withstand a collision, for example flowerbeds, bushes and fountains. Lay the wire up to and around the area to be isolated, and then return it back along the same route. If pegs are used, the wire should be laid under the same pegs on the return route. When the boundary wires to and from the island are laid close together, the robotic lawnmower can drive over the wire.

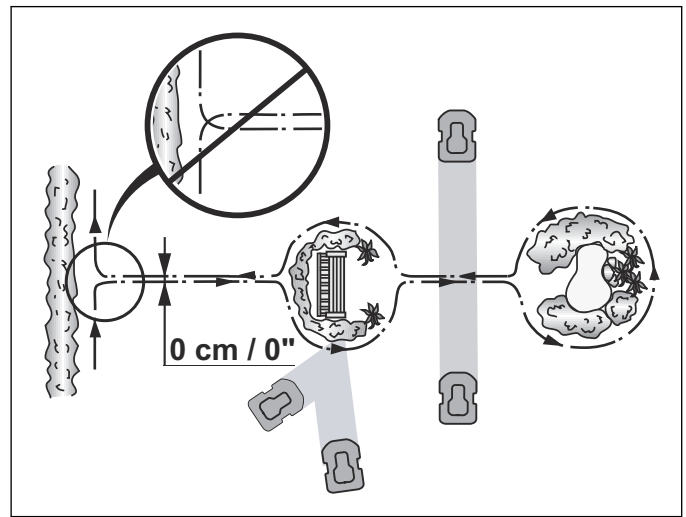

CAUTION: The boundary wire may not be crossed on its way to and from an island.

Obstacles that can withstand a collision, for example, trees or bushes taller than 15 cm / 6 in., do not need to be isolated with the boundary wire. The robotic lawnmower will turn around when it collides with this type of obstacle.

However, to achieve careful and silent operation, it is recommended to isolate all fixed objects in and around the working area.

Obstacles that slope slightly, for example stones or large trees with raised roots, must be isolated or removed. Otherwise the robotic lawnmower can slide up onto this kind of obstacle causing the blades to be damaged.

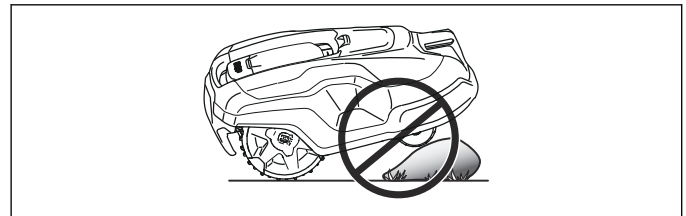

3.5.3.1 Secondary areas

If the working area consists of two areas which the robotic lawnmower has difficulty travelling between, it is recommended to set up a secondary area. Instances of this are 40% slopes or a passage that is narrower than 60 cm / in. Lay the boundary wire then around the secondary area so that it forms an island outside of the main area. The robotic lawnmower must be moved manually between the main and secondary area when the lawn in the secondary area has to be cut.

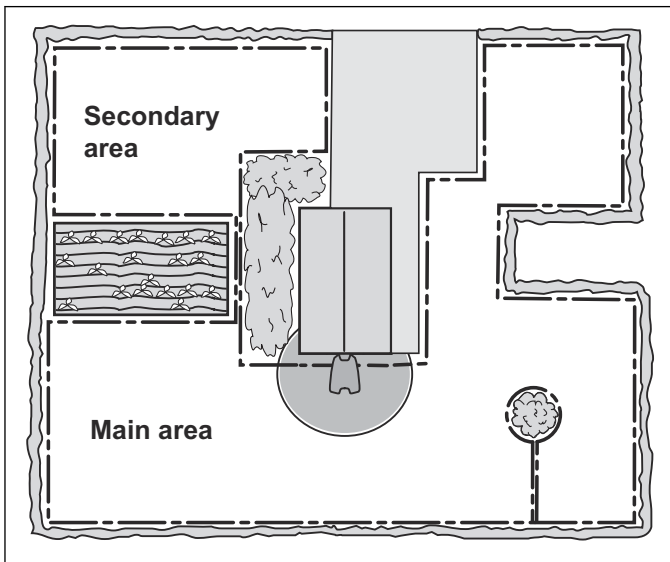

The *Secondary area* operating mode must be used as the robotic lawnmower cannot travel on its own from the secondary area to the charging station. See *Operating mode - Start* on page 43. In this mode, the robotic lawnmower will never look for the charging station but will mow until the battery runs out. When the battery is flat, the robotic lawnmower will stop and the *Needs manual charging* message will appear in the display. Place the robotic lawnmower in the charging station to charge the battery. If the main area has to be cut straight after charging, the **START** button must be pressed and the *Main area* selected before closing the hatch.

3.5.3.2 Passages when mowing

Long and narrow passages and areas narrower than 1.5 - 2 m / 3.2 - 6.5 ft. should be avoided. It is then a risk that the robotic lawnmower travels around in the passage or area for a period of time. The lawn will then look flattened. The narrowest possible passage for the robotic lawnmower is 60 cm / 24 in (between boundary wires).

Note: In passages narrower than 2 m / 6.5 ft. (between boundary wires) Husqvarna recommends that a guide wire is installed.

3.5.3.3 Slopes

The robotic lawnmower can operate in slopes. The maximum gradient is defined as percentage units (%) and is calculated as difference in elevation in centimetres for every meter. Inside the working area the robotic lawnmower can mow areas which slope up to 40%. Areas that slope more must be isolated with the boundary wire.

The boundary wire can be laid across a slope that slants less than 15%.

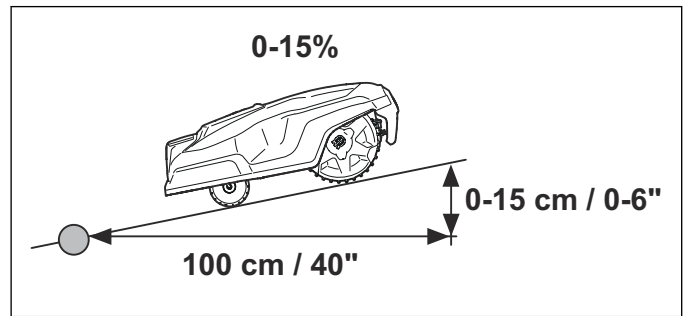

The boundary wire should not be laid across a slope that is steeper than 15%. There is a risk that the robotic lawnmower will find it difficult to turn there. The robotic lawnmower will then stop and the *Outside working area* fault message is displayed. The risk is at its greatest in damp weather conditions, as the wheels can slip on the wet grass.

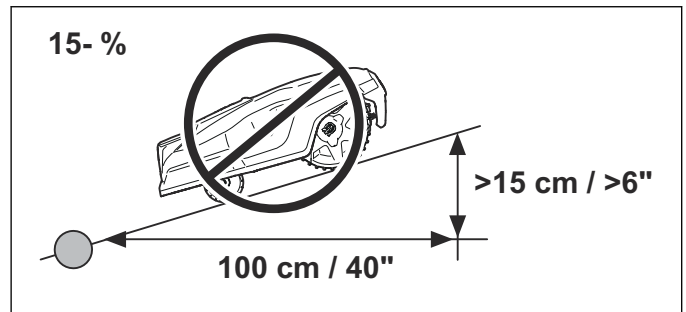

However, the boundary wire can be laid across a slope steeper than 15% if there is an obstacle that the robotic lawnmower is allowed to collide with, for example, a fence or a dense hedge.

When a part of the working area's outer edge slopes more than 15%, the boundary wire must be laid about 20 cm / 8 in. in on the flat ground before the beginning of the slope.

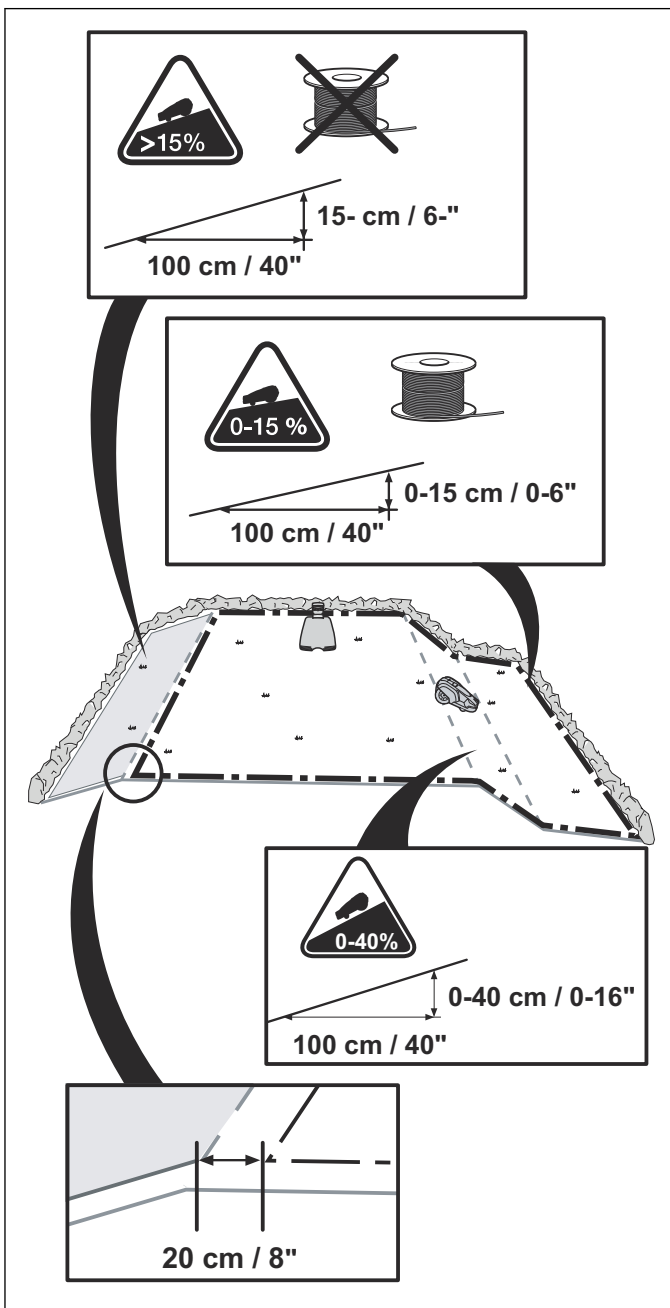

3.5.4 Laying the boundary wire

If you intend to staple down the boundary wire:

- Cut the grass very low with a standard lawnmower or a trimmer where the wire is to be laid. It will then be easier to lay the wire close to the ground and the risk of the robotic lawnmower cutting the wire or damaging the insulation of the wire is reduced.
- The boundary wire must lie close to the ground so as not to be cut before the grass roots have grown over it. Mowing the grass too low right after the installation can damage the wire insulation. Damage to the insulation may not cause disruptions until several weeks or months later. To avoid this, always select the maximum cutting height the first weeks after installation and then lower the height one step at a time every second week until the desired cutting height has been reached.
- Use a hammer to knock the pegs into the ground. Exercise care when knocking the pegs and make sure the wire is not under strain.

If the boundary wire is to be buried:

- Make sure to lay the boundary wire at a minimum of 1 cm / 0.4 in. and a maximum of 20 cm / 8 in. in the ground. The wire can be buried for instance using an edge cutter or a straight spade.

Note: Extra wire must not be placed in coils outside the boundary wire. This can disrupt the robotic lawnmower.

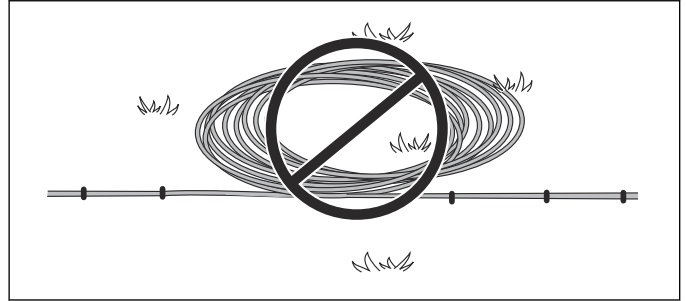

3.5.4.1 Eyelet for connecting the guide wire

To facilitate the connection of the guide wire to the boundary wire, it is recommended to create an eyelet with about 20 cm / 8 in. of extra boundary wire at the point where the guide wire will later be connected. It is a good idea to plan where the guide wire will be placed before laying out the boundary wire. See *Laying the boundary wire* on page 16.

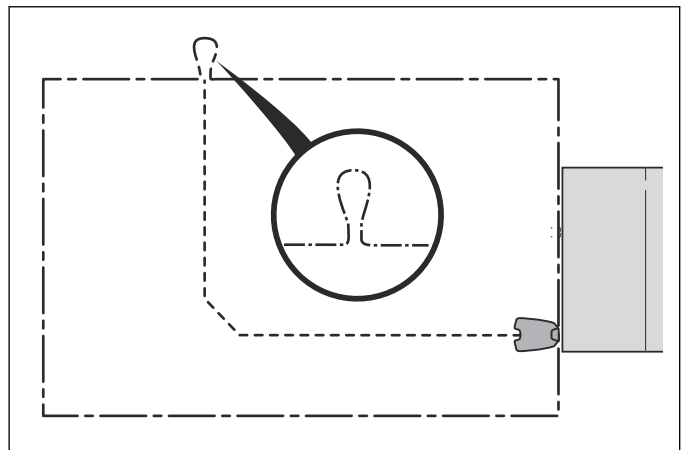

3.5.4.2 Laying the boundary wire in towards the charging station

The boundary wire can be laid completely outside the charging station (see option 1 in the figure). If there is a need to partly locate the charging station outside the working area, it is also possible to lay the wire under the charging station plate (see option 2 in the figure).

However most of the charging station must not be placed outside the working area as the robotic lawnmower can then find it difficult to find the charging station (see figure).

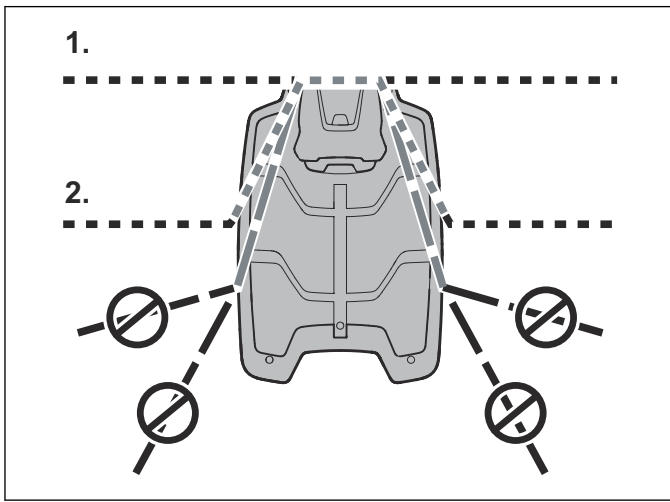

3.5.4.3 Splicing the boundary wire



CAUTION: Twinned cables, or a screw terminal block that is insulated with insulation tape are not satisfactory splices. Soil moisture will cause the wire to oxidise and after a time result in a broken circuit.

Use an original coupler if the boundary wire is not long enough and needs to be spliced. It is waterproof and gives a reliable electrical connection.

Insert both wire ends in the coupler. Check that the wires are fully inserted into the coupler so that the ends are visible through the transparent area on the other side of the coupler. Now press down the button on top of the coupler fully. Use a multigrip pliers to completely press down the button on the coupler.

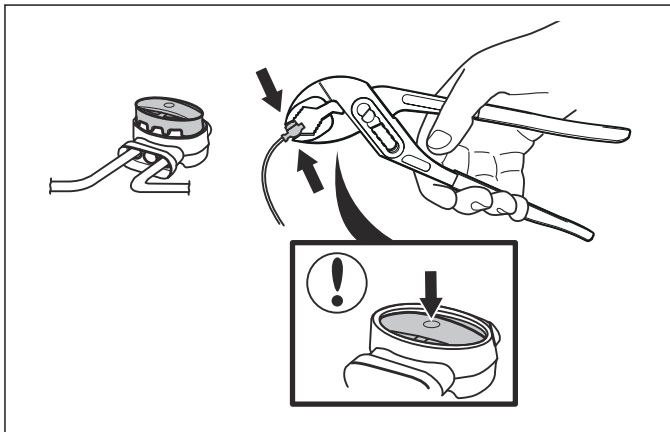

3.6 Connecting the boundary wire



CAUTION: The boundary wire must not be crossed when connecting it to the charging station. The right hand wire end must be connected to the right hand pin on the charging station and the left hand wire end to the left pin.

Connect the boundary wire to the charging station:

1. Open the connector and place the wire in the connector grip.

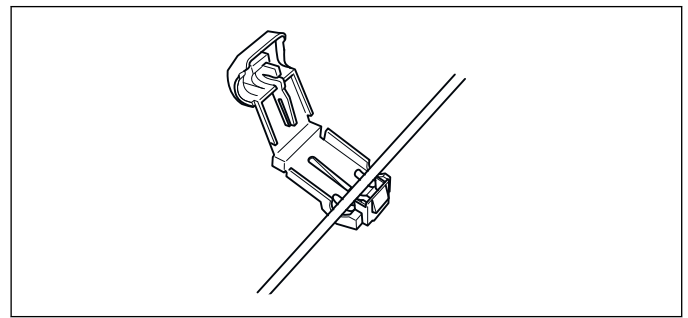

2. Press the connectors together using a pair of pliers. Press until you hear a click.

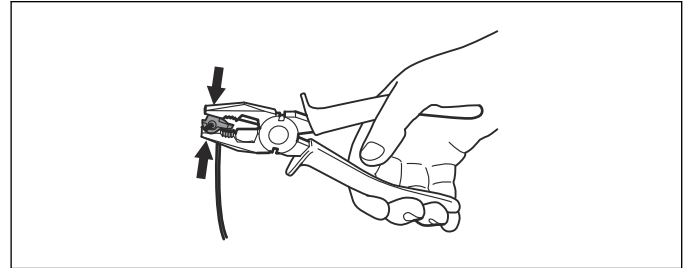

3. Cut off any surplus boundary wire. Cut 1-2 cm above each connector.

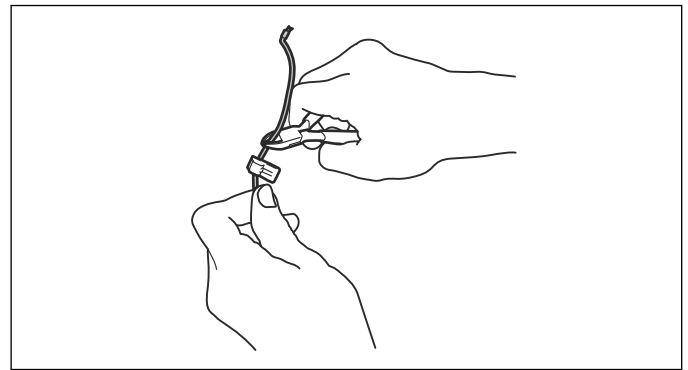

4. Tilt the protective cover on the charging station forward and run the wire ends up each channel at the rear of the charging station. Press the connector onto the metal pins, marked AL (left) and AR (right), on the charging station.
5. Mark the wires with the accompanying cable markers. This makes it easier to connect the wires correctly when for instance the charging station has been stored indoors for the winter.

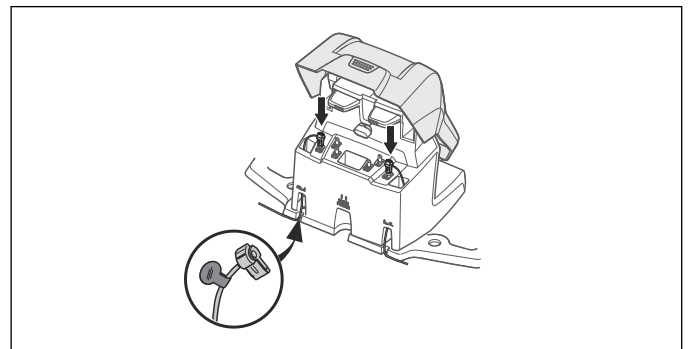

3.7 Installation of the guide wire

The guide wire is used by the robotic lawnmower to find its way back to the charging station but also to guide the robotic lawnmower to remote areas of the garden.

The same cable roll is used for both the boundary and guide wires. The guide wire, as the boundary wire, can be stapled to or buried in the ground.

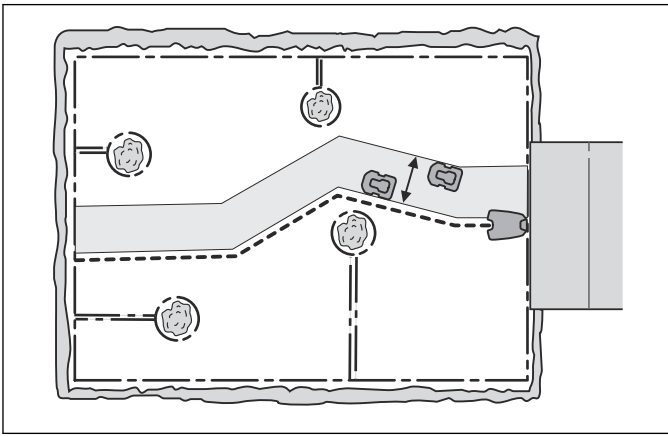

The robotic lawnmower runs at varying distances from the guide wire to reduce the risk of tracks forming. The area beside the wire which the robotic lawnmower then uses is called the Corridor. The wider the corridor allowed by the installation, the less the risk of tracks forming.

The robotic lawnmower always runs to the left of the guide wire as seen facing the charging station. Thus the corridor is to the left of the guide wire. When installing, it is therefore important to create as much free space as possible to the left of the guide wire, as seen facing the charging station.

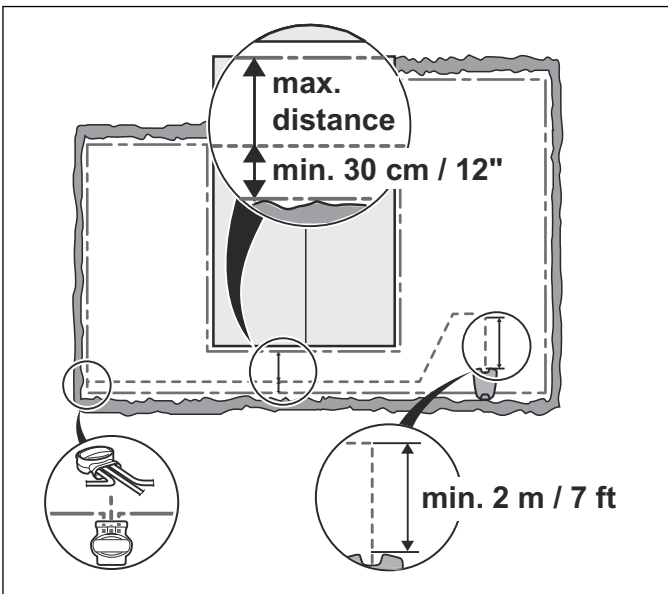

The guide wire, as the boundary wire, can be stapled to or buried in the ground.



CAUTION: Make as much space as possible to the left of the guide wire (as seen facing the charging station). Also, it is not allowed to lay the guide wire closer than 30 cm / 12 in. to the boundary wire.

3.7.1 Laying and connecting the guide wire

1. Before laying and connecting the guide wire, it is important to considerate the length of the guide wire, especially in large or complex installations. If the guide wire is longer than 400 m / 218 yd. the robotic lawnmower can have difficulty following it. The current in the guide wire always goes to the left at

the connection from the guide wire to the boundary loop.

2. Tilt the top cover on the charging station forward and run the guide wire through one of two channels marked GUIDE leading to the guide connection.
3. Fit a connector to the guide wire in the same way as for the boundary wire in *Connecting the boundary wire on page 17*. Connect it to the contact pin on the charging station that is labelled G1.
4. Mark the wires with the accompanying cable markers. This makes it easier to reconnect the wires correctly when for instance the charging station has been stored indoors for the winter.
5. Run the guide wire through the slot under the charging plate and then at least 2 m / 6.5 ft. straight out from the front edge of the plate.

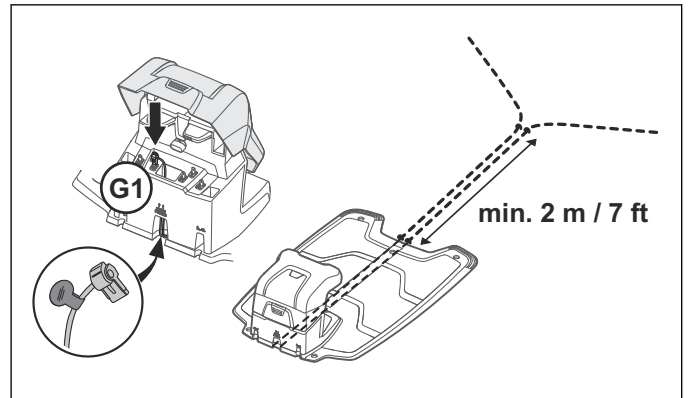

If the guide wire has to be installed on a steep slope, it is an advantage to lay the wire at an angle to the slope. This makes it easier for the robotic lawnmower to follow the guide wire on the slope.

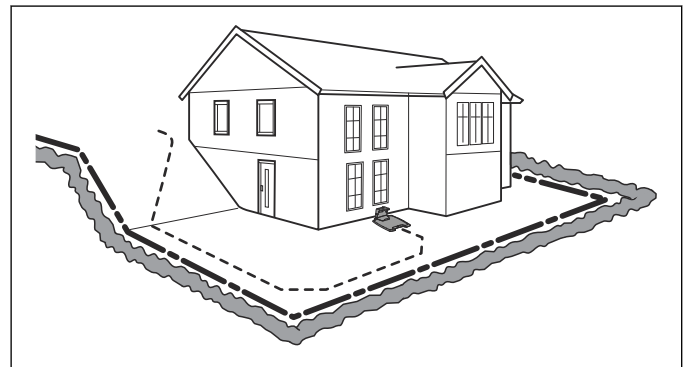

Avoid laying the wire at sharp angles. This can make it difficult for the robotic lawnmower to follow the guide wire.

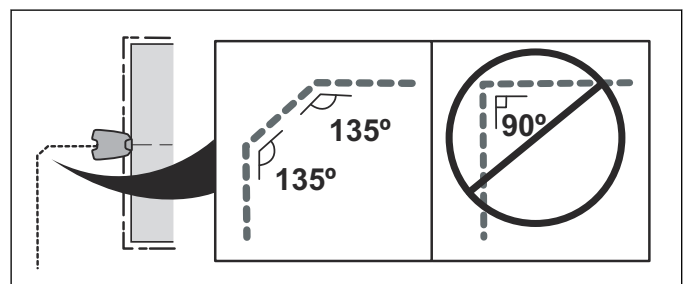

6. Run the guide wire to the point on the boundary loop where the guide wire is to be connected.
7. Cut the boundary wire using for instance a pair of wire cutters. Connecting the guide wire is made

easier if an eyelet has been made on the boundary wire as outlined in the previous description. See *Laying the boundary wire on page 16*.

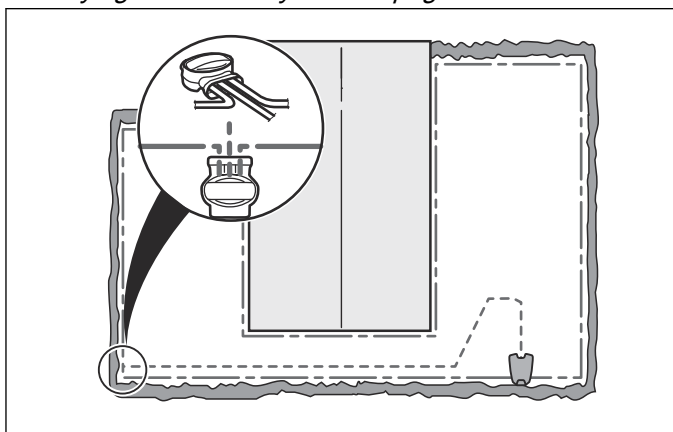

8. Connect the guide wire to the boundary wire using a coupler:
 - a) Insert the boundary wire and guide wire in the coupler. Check that the wires are fully inserted into the coupler so that the ends are visible through the transparent area on the other side of the coupler.
 - b) Use a multigrip pliers to completely compress the button on the coupler. It does not matter which holes are used to connect each wire.

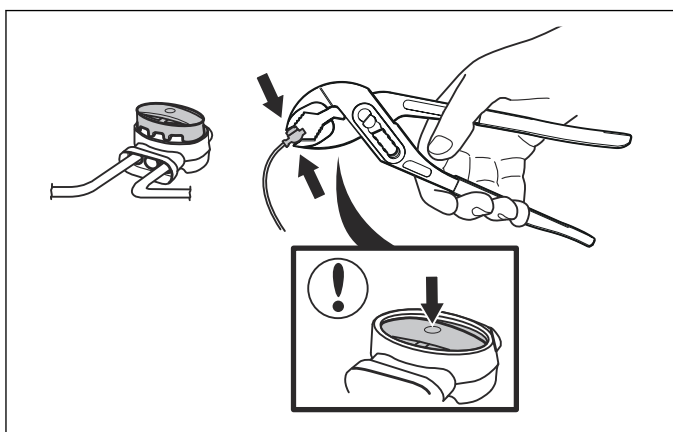

9. Staple down or bury the splice in the lawn.



CAUTION: The guide wire may not cross the boundary wire, for instance a boundary wire that is laid out to an island.

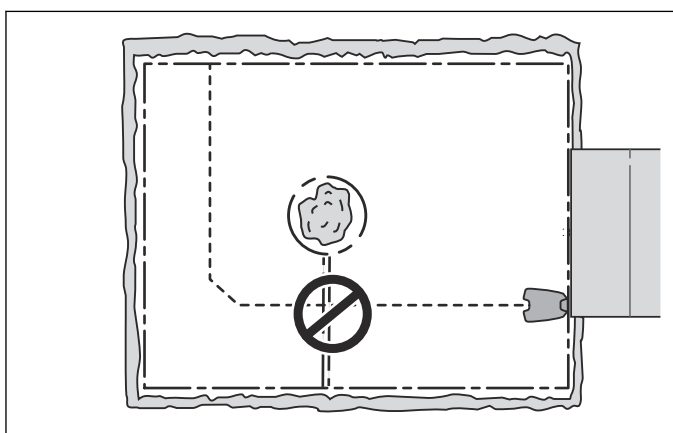

3.8 Checking the installation

Check the loop signal by inspecting the indicator lamp on the charging station.

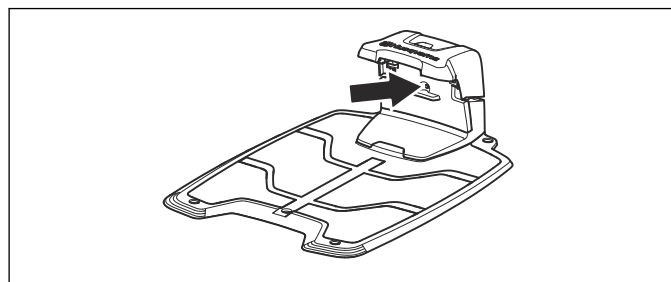

See *Indicator lamp in the charging station on page 52* if the lamp does not indicate a solid or flashing green light.

3.9 First start-up and calibration

When the main switch is set to position 1 for the first time, a start-up sequence in the robotic lawnmower's menu must be carried out as well as an automatic calibration of the guide signal.

1. Open the hatch by pressing the **STOP** button.
2. Set the main switch to position 1.

A start-up sequence begins when the robotic lawnmower is started for the first time. The following is requested:

- Language.
- Country
- Date
- Time
- Selection and confirmation of personal PIN code. All combinations except 0000 are permitted.

Note: Use the *MEMO* page at the beginning of the manual to make a note of the PIN code.

3. Place the robotic lawnmower in the charging station and press **START**. The robotic lawnmower will now begin to calibrate the guide wire.

Press **START** and close the hatch. The calibration is performed by the robotic lawnmower backing out of the charging station and running a calibration process in front of the charging station. When this is completed, mowing can begin.

3.10 Pairing with the Automower® Connect app

If the first start-up process already has been carried through, the next operator follows the normal pairing process.

The normal pairing process between the Automower® Connect app and the product involves the following steps:

1. Download the Automower® Connect app and create an account. Refer to *Connectivity on page 21*.
2. Log in to your Automower® Connect account in the app.
3. Set the **Main switch** to position 1 on the product.

Note: The product is available for pairing for 3 minutes. If pairing has not been successful within this time period, turn off the product (**Main switch**, position 0). Wait until the LED indicator lamp goes out, and then set the **Main switch** to position 1 again.

4. Enter the PIN code for the product.
5. Select *My mowers* in the Automower® Connect app, and then select the plus sign (+).
6. Select model. The Automower® Connect app is now searching for available products within short-range.
7. For Automower® 310 and Automower® 315 without Automower® Connect:
 - a. Enable Bluetooth® mode on your mobile device.

The Automower® Connect app is now searching for available products within short-range.
 - b. Select the product.
8. For Automower® 315X, Automower® 310 and Automower® 315 equipped with accessory Automower® Connect:
 - Follow the pairing instructions in the app.
9. Name your product, and select *Done*.

3.11 Automower® Connect menu

The main menu in Automower® Connect offers 4 options:

- *Dashboard*
- *Map* (only available with Automower® Connect)
- *Settings*
- *Messages* (only available for Bluetooth short-range connectivity)

3.11.1 Dashboard

The dashboard shows the current status of the robotic lawnmower both visually and in text. It is very easy to control the robotic lawnmower by tapping the controls, for example *Park*.

In the lower part of the dashboard there are shortcuts to the *Timer settings* and the *Map*. The dashboard also shows symbols according to below:

1. The battery status shows the remaining battery charge. A flash is shown over the battery symbol when the robotic lawnmower charges its battery. A plug is shown over the battery symbol when the robotic lawnmower is standing in the charging station without charging.

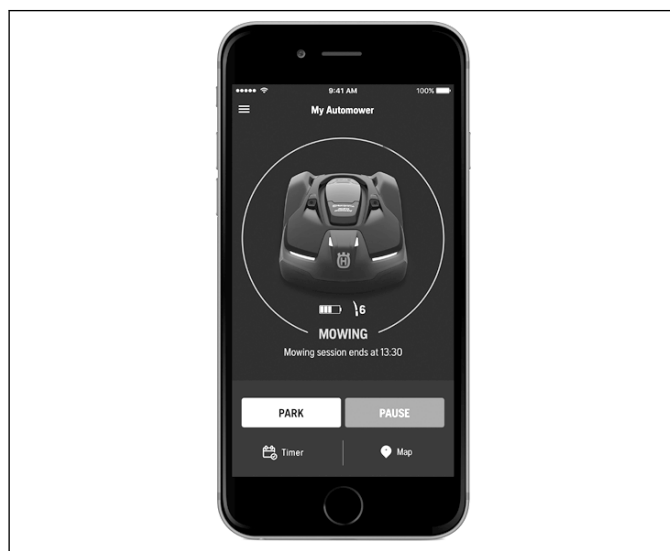

For more information about the operating modes *Start*, *Park* and *Pause*, see *Operation on page 43*.

3.11.2 Map

The map shows the current position of the robotic lawnmower and the set centerpoint (origin) for GeoFence.

3.11.2.1 Map settings

1. Open *Map* in the main menu.
2. Tap the settings symbol down to the right.
3. Enable/disable *Movement path*.
4. Choose *Map view* or *Satellite view*.

3.11.3 Settings - overview

For many working areas there is no need to change the default settings. However sometimes, depending on the lawn complexity, the mowing result can be improved by making manual settings. The following settings can be done in the Automower® Connect app:

- *Timer*
- *Operation*
- *Installation*
- *Accessories*

The timer function is an ideal tool to control which periods the robotic lawnmower should not mow, for example when children are playing in the garden. See *Timer and Standby on page 44*

For an overview of possible settings, refer to *Menu structure overview on page 37*.

3.11.4 Messages

In this menu the previous fault and information messages can be found. For some of the messages, there are tips and advice to help to rectify the fault.

Note: The *Messages* menu is only available for Bluetooth short-range connectivity.

If the robotic lawnmower is disrupted in any way, for example it is trapped or the battery is low, a message is saved relating to the disruption and the time it happened.

If the same message is repeated several times, this may indicate that an adjustment to the installation or the robotic lawnmower is required. See *Troubleshooting on page 48* or *Messages on page 26*.

3.11.5 My mowers

When choosing *My mowers* you can manage all the robotic lawnmowers paired to your account, as well as add new ones. If there are several paired robotic lawnmowers it is possible to select one of them as *Current mower*.

To pair a new product to the Automower® Connect app, refer to *Pairing with the Automower® Connect app on page 19*.

3.12 Connectivity

The Automower® Connect app allows you to monitor, control and configure your robotic lawnmower conveniently on your mobile device. You will also receive push notifications from the app, for example if the robotic lawnmower is stopped.

The app provides two modes of connectivity: Long-range cellular connectivity and Short-range Bluetooth connectivity. Automower® 310 and Automower® 315 support Bluetooth communication. If equipped with Automower® Connect, they support also cellular communication. Refer to *Automower® Connect on page 21*.

If the robotic lawnmower is equipped with Automower® Connect, it is also possible to monitor and control your robotic lawnmower if you are subscribing to Husqvarna Fleet Services. Refer to *Husqvarna Fleet Services on page 21*.

3.12.1 Automower® Connect

Automower® Connect is included in Automower® 315X and is available as accessory for Automower® 310 and Automower® 315.

Automower® Connect brings the product's menu system to your mobile device, making it easy to read and change the product's settings remotely. Through this application, you can receive the status of your Automower® and send commands to the product from anywhere in the world. In case of theft, you will get an alarm and be able to track your product's position. Some countries do not support Automower® Connect due to region specific cellular systems. Please, contact your local Husqvarna representative for more information.

3.12.2 Getting started

Download the Automower® Connect app from AppStore or GooglePlay. Once you have downloaded the app, you can specify an e-mail address and a password to create an account. You will receive a validation e-mail to the e-mail address you specified. Follow the instructions in the e-mail within 24 hours to validate your account. If not validated within 24 hours, you will have to create your account again. When the account has been created in the app, you can pair the robotic lawnmower and your mobile device. See *Pairing with the Automower® Connect app on page 19*.

To get started with Husqvarna Fleet Services™ app, see *Husqvarna Fleet Services on page 21*.

3.12.3 Automower® Direct

Automower® Direct uses short-range Bluetooth communication, and is available for Automower® 310 and Automower® 315.

Note: If Automower® 310 or Automower® 315 has been equipped with the accessory Automower® Connect, disable Automower® Connect in the *Accessories* menu in the product.

Husqvarna cannot guarantee the uptime or coverage of the 3rd party data connection (long-range connectivity). However, it is always possible to communicate with the product via Bluetooth, as long as you are within short-range of the product. Automower® Direct is, for example, useful if the operator has the Automower® Connect app and the PIN code, but has not created a Husqvarna account.

1. Select Automower® Direct.
2. Activate Bluetooth pairing on the product:
 - a. Turn off the robotic lawnmower (**Main switch**, position 0).
 - b. Wait until the LED indicator lamp goes out, and then set the **Main switch** to position 1 again. Bluetooth pairing mode is active for 3 minutes.
 - c. Select the product to pair with.
 - d. Enter the PIN code for the product. When the pairing has been confirmed, you have access to the menus and functions as long as you are within short-range (Bluetooth).

How to pair with the robotic lawnmower when using Husqvarna Fleet Services™ app:

Note: Both the Husqvarna Fleet Services™ app and the Automower® Connect app must be downloaded to your smartphone.

1. Log in to the Husqvarna Fleet Services™ app, and follow the instructions for how to pair with a robotic lawnmower. Pairing is done by using Automower® Connect in conjunction with the Husqvarna Fleet Services™ app.
2. Follow step 2-4 above.
3. Select *Settings > Automower® Connect > Initiate new pairing*.
4. Confirm pairing.

3.12.4 Husqvarna Fleet Services

Husqvarna Fleet Services™ is a cloud solution that gives the commercial fleet manager an updated overview of all the machines. Automower® 315X can be added to Husqvarna Fleet Services™ and upload valuable data. If Automower® 310 and Automower® 315 are equipped with Automower® Connect, they can also be added to Husqvarna Fleet Services™. The data is transferred automatically and wirelessly to the Husqvarna Fleet Services™ pages. All this gives the best possible prerequisites for planning the business ahead, to ensure high uptime, productivity and good profitability. The

products are paired to the rest of the fleet by using the Automower® Connect app in conjunction with the Husqvarna Fleet Services™ app, which is available at AppStore and GooglePlay. There is more information about Husqvarna Fleet Services™ and how to subscribe to the services on www.husqvarna.com.



3.13 Test docking with the charging station

Before using the robotic lawnmower, check that the robotic lawnmower can follow the guide wire all the way to the charging station and easily docks with the charging station.

The test function is found in the robotic lawnmower's *Installation > Find charging station > Guide > More > Test guide* menu. For more information, see *Boundary > More > Test right / Test left on page 30*.

If no guide wire is installed the test should be carried out on the boundary wire, both clockwise and anti-clockwise.

The guide system must first be calibrated if the above test is to provide a satisfactory result. See *First start-up and calibration on page 19*.

3.14 Control panel

3.14.1 Control panel

All commands and settings for the robotic lawnmower are done on the control panel. The control panel consists of a display and a keypad. All information is shown on the display and all input is done using the buttons.

3.14.2 Keypad

The keypad consists of 6 groups of buttons:

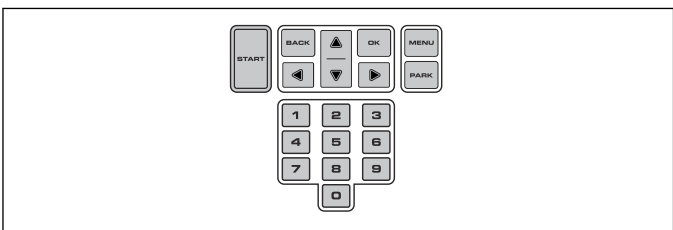

- The **START** button is used to activate the robotic lawnmower. This is normally the last button to be pressed before closing the hatch.

- The **BACK** and **OK** buttons are used to navigate in the menu. The **OK** button is also used to confirm settings.
- The **arrow keys** are used to navigate in the menu but also to make selections in certain setting options.
- The **MENU** button is used to go to the main menu.
- The **PARK** button is used to send the robotic lawnmower to the charging station.
- The **number keys** are used to enter settings, for example PIN code, time or exit direction.

3.14.3 Display

When the **STOP** button has been pressed and the hatch is opened, the display is showing the following information:



- Operating information, e.g. *MOWING*, *PARKED* or *TIMER*. If the stop button is pressed when the robotic lawnmower is running, what it did just before it was stopped e.g. *MOWING* or *SEARCHING* is displayed. The text *READY* is displayed if the robotic lawnmower is not in any specific operating mode, e.g. if the main switch has just been turned on.
- Date and clock show the current time:

3.14.4 Symbols shown on the display

The black clock symbol (A) indicates when the mower is not allowed to mow due to a timer setting. If the mower is not allowed to mow due to Weather timer, symbol (B) is shown (not applicable for Automower® 310). If the operation mode Override timer is chosen, symbol (C) is shown.

The battery status shows the remaining battery charge. If the robotic lawnmower is loading, a flash is also shown over the battery symbol (D). If the robotic lawnmower is placed in the charging station without charging, (E) is shown.

The ECO symbol (F) is displayed if the robotic lawnmower is set in *ECO mode*.

Below symbols are valid for Automower® 315X:

The satellite symbol is shown when GPS assisted navigation is enabled. Symbol (G) is displayed when the robotic lawnmower has established contact with a sufficient number of GPS satellites. Symbol (H) is displayed if the robotic lawnmower does not have contact with a sufficient number of satellites. Symbol (G) flashes during the first days the robotic lawnmower is working as it gathers GPS information concerning the installation

With Automower® Connect activated, additional symbols (I, J, K) are displayed on the product's display:

The bars show the signal strength of the GPRS reception. An X next to the bars indicates that there is

no GPRS reception. The SIM symbol (K) indicates there is a problem with the SIM card or the SIM module. Make sure the SIM card support local data communication, and that there is sufficient funds on the card (applies to pre-paid SIM cards). Also make sure that APN settings agree.

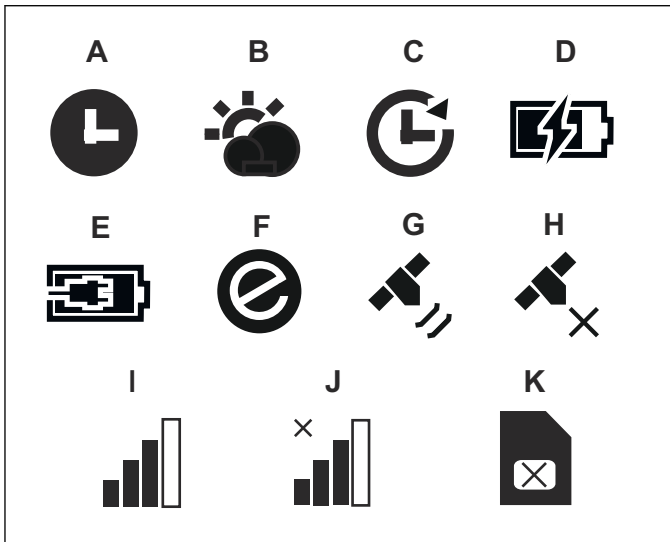

3.14.5 Submenus

There are a number of submenus under each option. You can access all the functions to set the robotic lawnmower settings via the submenus.

Certain submenus contain options that are ticked off to the left. This means that these options are selected. Check or uncheck the box by pressing the **OK** button.

3.15 Menu structure

The main menu for Automower® 315 offers 7 options:

- *Timer*
- *Security*
- *Messages*
- *Weather timer*
- *Installation*
- *Settings*
- *Accessories*

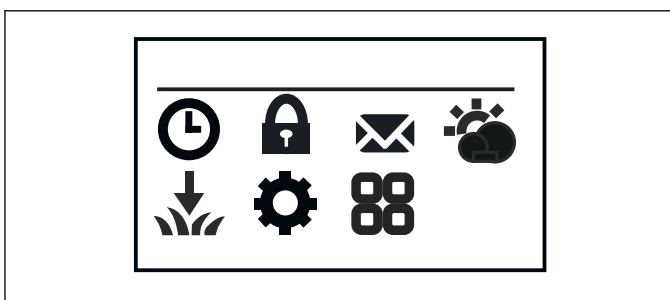

The main menu for Automower® 310 offers 6 options:

- *Timer*
- *Security*
- *Messages*
- *Installation*
- *Settings*
- *Accessories*

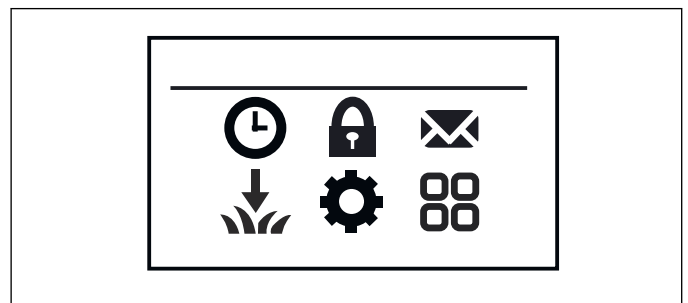

3.15.1 Main menu



Timer

The timer function is an ideal tool to control which periods the robotic lawnmower should not mow, for example when the children are playing in the garden. See *Timer on page 24*



Security

In this menu, settings relating to security and the connection between the robotic lawnmower and the charging station can be made. There are 3 security levels to choose from: *Low, Medium, High*. See *Security on page 25*.



Messages

Historical fault and information messages can be read in this menu. For some of the most common fault messages, there are tips and advice to help you rectify the fault. See *Messages on page 26*.



Weather timer

Only for Automower® 315

This function allows the robotic lawnmower to automatically adjust its mowing times based on how much the lawn grows. When the weather is good for grass growth, the robotic lawnmower mows more often and when grass growth is slower the robotic lawnmower will automatically spend less time on the lawn. See *Weather timer on page 27*.



Installation

This menu function is used to customize the installation. For many working areas there is no need to alter the factory settings, but depending on the lawn complexity the mowing result can be improved by making manual settings. See *Installation on page 27*.

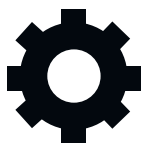

Settings

This selection allows you to make changes to the general robotic lawnmower settings such as date and time. You can also turn on/off *ECO mode* and *Spiral cutting*, or save your settings in different *Profiles* (Automower® 315 only). See *Settings on page 32*.



Accessories

This menu handles the settings for robotic lawnmower accessories, for examples Automower Connect. Contact your local Husqvarna representative for information on what accessories are available for your robotic lawnmower. See *Accessories on page 34*.

3.16 Timer

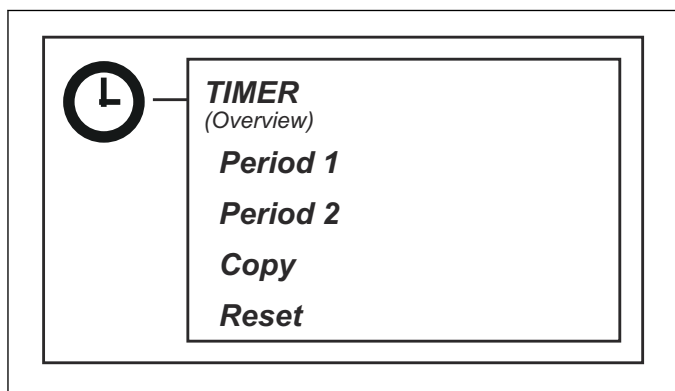

The lawn should not be cut too often to obtain the best mowing result. When the robotic lawnmower is allowed to mow too much, the lawn may appear flattened. Besides, the robotic lawnmower is subjected to unnecessary wear. If the working area is less than the robotic lawnmower's area capacity, the quality of the grass can be further improved if it is cut every other day instead of a few hours every day. In addition, the grass benefits from resting completely during at least a three-day period once a month.

The timer function is also an ideal way to control which periods the robotic lawnmower should not mow, for example, when the children are playing in the garden.

3.16.1 Timer suggestions Automower® 310

Work area	Work days per week	Work hours per day	Suggestion of time interval
250 m ²	5	6.5	07:00 - 13:00
	7	4.5	07:00 - 11:30
500 m ²	5	12.5	07:00 - 19:00
	7	9	07:00 - 15:30
750 m ²	5	18	06:00 - 24:00
	7	13.5	07:00 - 20:30
1000 m ²	7	18	06:00 - 24:00

The operating hours and days can be seen in an overview on the robotic lawnmower's display. Active mowing per day is illustrated by a black bar. The rest of the time, the robotic lawnmower is parked in the charging station.

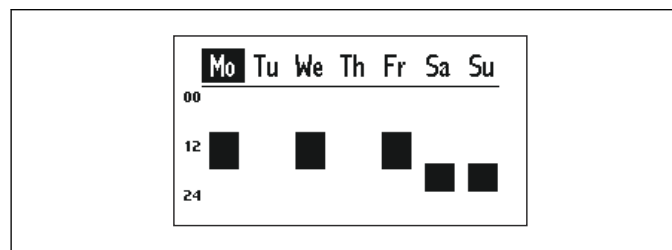

The factory timer setting is inactive, which means that the robotic lawnmower will operate around the clock 7 days a week. This is normally a suitable setting for a working area corresponding to the maximum capacity, see *Timer and Standby on page 44*.

If the working area is less than maximum capacity then the timer should be used to minimize wear on grass and lawnmower. When setting the timer, calculate that the robotic lawnmower mows about the number of square meters per hour and day listed in table Work capacity. See *To set the timer on page 44*.

The table below provides suggestions for different timer settings depending on the size of the lawn. The times should be seen as indicative. They may need to be adjusted to suit the garden and for example grass quality and growth during the season. Use the table as follows:

- Find a work area that closest matches the size of the lawn.
- Select an appropriate amount of work days (for some work areas 7 days may be needed).
- Work hours per day shows how many hours a day the robotic lawnmower will be allowed to work for the selected amount of work days.
- Suggested time interval shows a time interval that corresponds to the required work hours per day.

It is possible to configure 2 work periods a day. There can be unique work periods in each day, but it is also possible to copy the current day's work period to all the other days.

3.16.2 Timer suggestions Automower® 315

Work area	Work days per week	Work hours per day	Suggestion of time interval
250 m ²	5	5.5	07:00 - 12:30
	7	4	07:00 - 11:00
500 m ²	5	10.5	07:00 - 17:30
	7	7.5	07:00 - 14:30
750 m ²	5	15.5	07:00 - 22:30
	7	11	07:00 - 18:00
1000 m ²	5	21	03:00 - 24:00
	7	15	07:00 - 22:00
1250 m ²	7	18.5	05:30 - 24:00
1500 m ²	7	22	02:00 - 24:00

3.16.3 Edit day

First select the day to edit from the Overview screen using the left/right **arrow keys** followed by **OK**.

2 time intervals per day can be entered. To enter an interval for *Period 1*, first make sure that the check box next to *Period 1* is checked. To check/uncheck select the check box and press **OK**. Enter the time using the numeric keypad.

Period 2 is entered the same way as *Period 1*. Two intervals can be useful for enabling the lawn for other activities during certain hours, for example by entering *Period 1*: 00:00- 15:00 and *Period 2*: 21:00-24:00. The mower will then be parked in the charging station between 15:00 and 21:00.

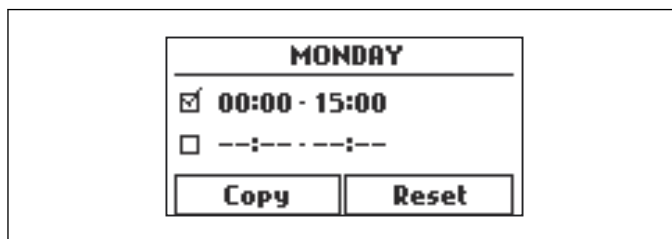

To disable mowing a whole day, uncheck both periods.

3.16.4 Copy

Use this function to copy the current day settings to other days.

Mark *Copy* by using **arrow keys** and press **OK**. Then use the up and down **arrow keys** to move the cursor between days. The times will be copied to the days that are marked with **OK**.

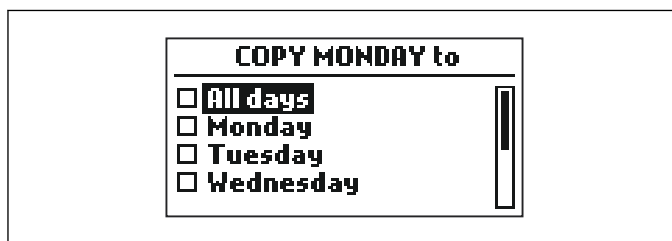

3.16.5 Reset

This function resets the timer to the factory setting, where the robotic lawnmower is allowed to operate 24 hours a day every day.

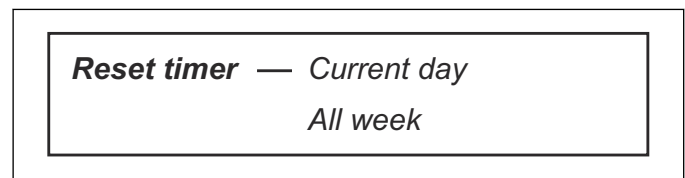

3.16.5.1 Current day

This resets the day that is selected in the tab system.

The factory setting is that the robotic lawnmower is allowed to operate 24 hours a day.

3.16.5.2 All week

This resets all days in the week.

The factory setting is that the robotic lawnmower is allowed to operate 24 hours a day every day.

3.17 Security

Through this selection, settings relating to security and the connection between the robotic lawnmower and the charging station can be made.

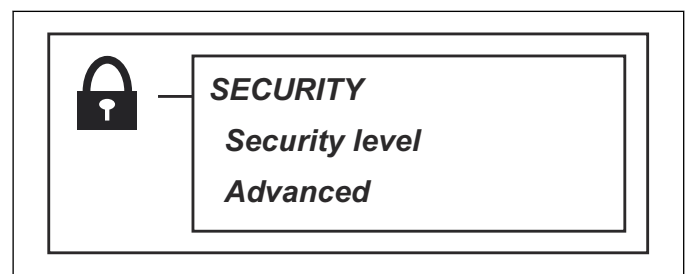

3.17.1 Security level

There are 3 security levels to choose from.

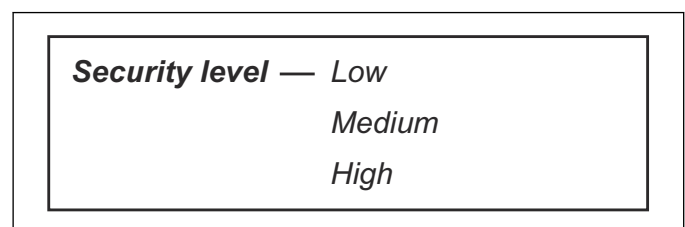

Low and *Medium* security prohibits access to the robotic lawnmower if the PIN code is unknown. *High* security also includes a warning that beeps if the correct PIN code is not entered after a designated time period.

If the wrong PIN code is entered 5 times in succession the robotic lawnmower is blocked for a time. The blockage time is extended for every new incorrect attempt.

Function	Low	Medium	High
Time lock	X	X	X
PIN request		X	X
Alarm			X

3.17.1.1 Time lock

This function means that the robotic lawnmower cannot be started after 30 days without first entering the correct PIN code. When the 30 days has passed the robotic lawnmower will continue to mow as normal, but the *Enter PIN code* message appears the next time **STOP** is pressed. Enter the PIN code and press **OK**.

3.17.1.2 PIN request

This function means that the robotic lawnmower requests a PIN code if the robotic lawnmower is in standby and has the security setting *High*. Standby (flashing indicator lamp) means that the operator must press the **ON/OFF** button to make the robotic lawnmower active again. The correct PIN code must be entered before it is possible to operate the robotic lawnmower.

3.17.1.3 Alarm

This function means that an alarm sounds if the PIN code is not entered within 10 seconds after the **STOP** button has been pressed or the robotic lawnmower has been lifted up for any reason. A ticking noise indicates that the PIN code must be entered to prevent triggering the alarm. The alarm can be turned off at any time by entering the correct PIN code.

3.17.2 Advanced

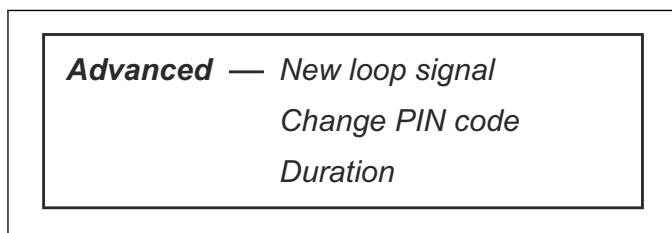

3.17.2.1 New loop signal

The loop signal is randomly selected to create a unique link between the robotic lawnmower and the charging station. In rare cases, there may be a need to generate a new signal, for instance if two adjacent installations have a very similar signal.

1. Place the robotic lawnmower in the charging station.
2. Select *New loop signal* in the menu.
3. Press **OK** and await confirmation that the loop signal has been generated. This normally takes about 10 seconds.

3.17.2.2 Change PIN code

1. Enter the current PIN code by using the up/down arrow keys and press **OK**.
2. Enter the new PIN code and press **OK**.
3. Confirm by entering the same code again and press **OK**.

When the PIN code is changed, the message *PIN code changed* appears in the display. Make a note of the new PIN code on the designated line in Memo. See *Introduction on page 3*.

3.17.2.3 Duration

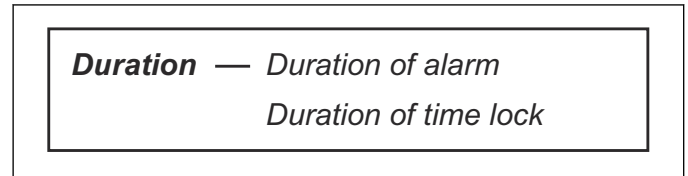

Duration of alarm

When *Alarm* is activated (*High* security) there is also the possibility to select how long the alarm signal should last. A figure between 1 and 20 minutes can be selected.

Duration of time lock

A time lock can be set to decide how many days will pass before the PIN must be entered before use. 1-90 days can be selected.

3.18 Messages

In this menu the previous fault and information messages can be found. For some of the messages, there are tips and advice to help to rectify the fault.

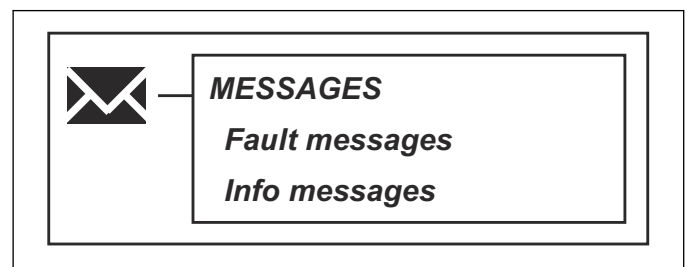

3.18.1 Fault messages

If the robotic lawnmower is disrupted in any way e.g. gets stuck under a fallen branch a message is shown in the lawnmower's display relating to the disruption and the time it happened.

If the same fault message is repeated several times, this may indicate that an adjustment to the installation or the robotic lawnmower is required. See *Fault messages on page 48* for more information on possible reasons for each message.

The list contains the latest 50 fault messages sorted by date with the last incident to occur first on the list.

The date and time when the fault messages are displayed can be shown by selecting a fault message and pressing the **OK** button.

Tips and advice to help you rectify the fault, are also displayed.

3.18.2 Info messages

Messages shown in the display not caused by an actual fault are instead saved under the *Info messages* heading. Examples for such messages is *Slope too steep*. See *Information messages on page 51* for more information on possible reasons for each message.

The list contains the latest 50 fault messages sorted by date with the latest incident to occur first on the list.

3.19 Weather timer

Only applicable for Automower® 315 and Automower® 315X

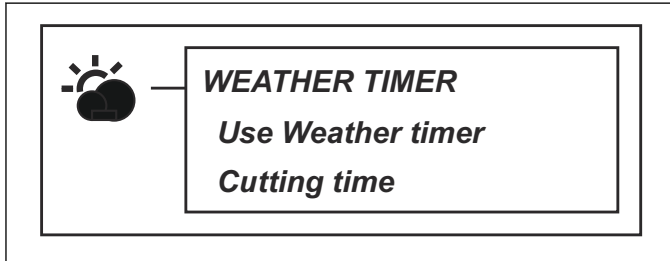

This function allows the product to automatically adjust its mowing times based on how quickly the lawn grows. When the weather is good for grass growth, the product mows more often and when the grass growth is slower the product will automatically spend less time on the lawn. The first mowing cycle of the day will however always be completed. After that, Weather timer will decide whether to continue or not.

For optimal Weather timer performance, it is recommended to only deselect the times when the product must not operate. All other time should be made available for the Weather timer. Manual timer settings always have priority over Weather timer so the product will not be allowed to mow more than the timer settings.

When the Weather timer is activated, the product needs time to decide what the optimal mowing time is for the working area in question. For this reason it can take a couple of days of calibration before the mowing results are optimal.

Please, note that Weather timer is reset if the product has been shut down for more than 50 hours or if a *Reset of all user setting* is done. Weather timer is not affected if a reset of timer setting is done.

When the Weather timer is activated, it is very important to regularly check that the blade disc is clean and that the blades are in good condition. Any grass twisted around the blade disc shaft or blunt blades can affect how the Weather timer functions.

3.19.1 To activate the weather timer

Check the box by pressing **OK** to activate the weather timer.

3.19.2 Cutting time

If the mowing results are not optimal when using the *Weather timer*, *Cutting time* settings may need adjusting.

The longer cutting time that is chosen, the longer the robotic lawnmower will be allowed to work.

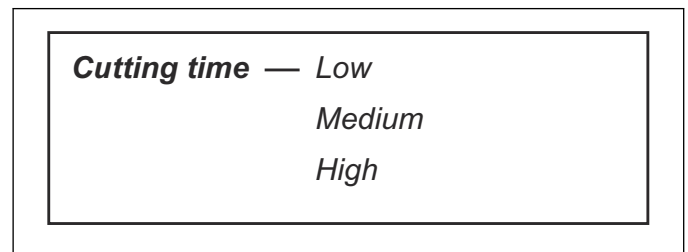

3.19.2.1 To adjust the cutting time

1. Place the cursor by *Cutting time* and press **OK**.
2. Use the right and left **arrow keys** to increase or decrease the cutting time in 3 preset intervals.

3.20 Installation

For many working areas there is no need to change the factory settings but sometimes, depending on the lawn complexity, the mowing result can be improved by making manual settings.

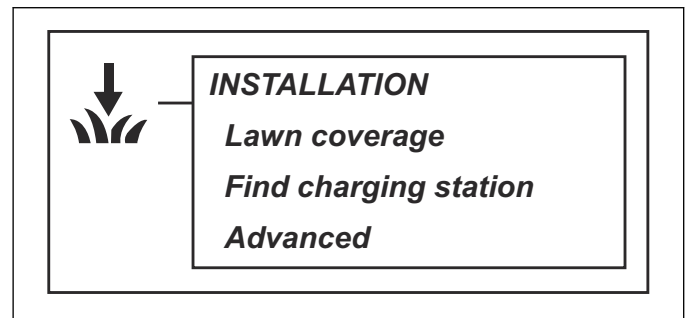

3.20.1 Lawn coverage (Automower® 310 and Automower® 315)

This menu function is used to steer the product to remote parts of a working area. In complex gardens with for instance many areas which are joined by narrow passages, the mowing result can be much improved by changing settings.

Up to 3 remote areas can be set. Select an area using the left and right **arrow keys** followed by **OK**.

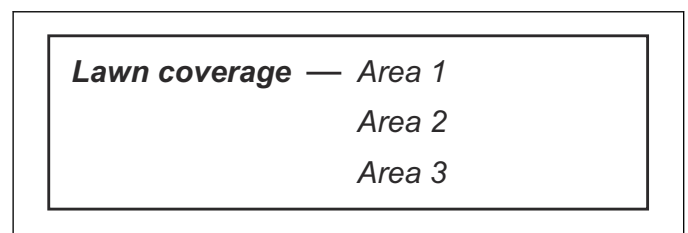

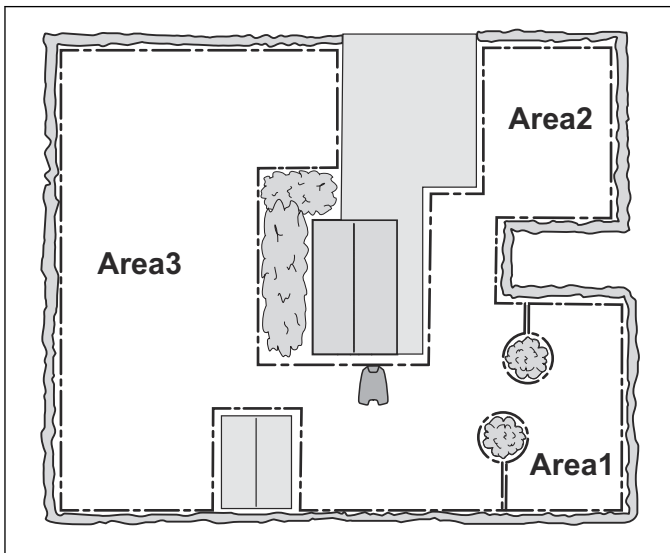

A number of unique selections are required to allow the product to reach the remote area.

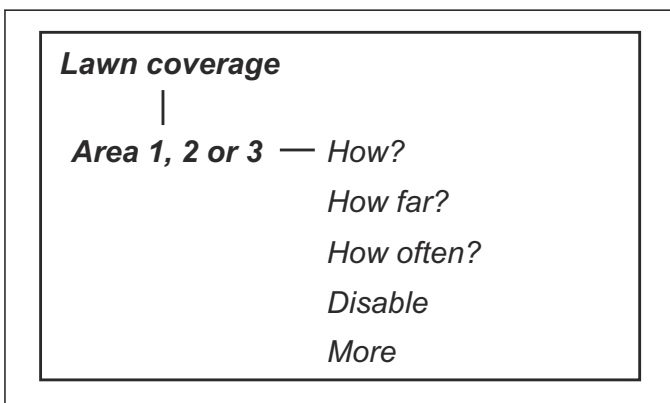

The factory settings allow the product to follow the guide wire 300 m in 20% of the times it leaves the charging station. If the guide wire in reality is less than 300 m the product will follow it to the point where the guide wire is connected to the boundary wire.

3.20.2 Lawn coverage (Automower® 315X)

The GPS assisted navigation helps the product find the most efficient way to cut the grass and obtain an optimal result. It creates a map of the yard, including the boundary and guide wires. The product knows which areas have not been mown yet, and therefore goes there so that all parts of the yard are covered.

3.20.2.1 Area 1, 2 or 3 > How?

Specify to the right, left or Guide depending on which direction the robotic lawnmower should go. The direction (right or left) is counted as that seen facing the charging station.

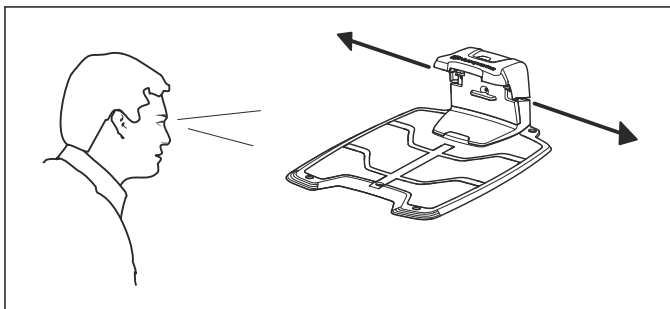

Use the right and left **arrow keys** to alternate between the different options.

3.20.2.2 Area 1, 2 or 3 > How far?

Enter the distance in metres along the current wire from the charging station to the remote area where the robotic lawnmower begins mowing.

Use the right and left **arrow keys** to alternate between the different options.

Tip! Use the *Test* function (*Area 1, 2 or 3 > More > Test*) to determine how far it is to the remote area. The distance, stated in metres, will be shown in the lawnmower display when **STOP** has been pressed. See *How to measure the distance to a remote area on page 29*. The measured distance shown in the display can be saved directly to the selected remote area. Any current value will be overridden by the new measured distance.

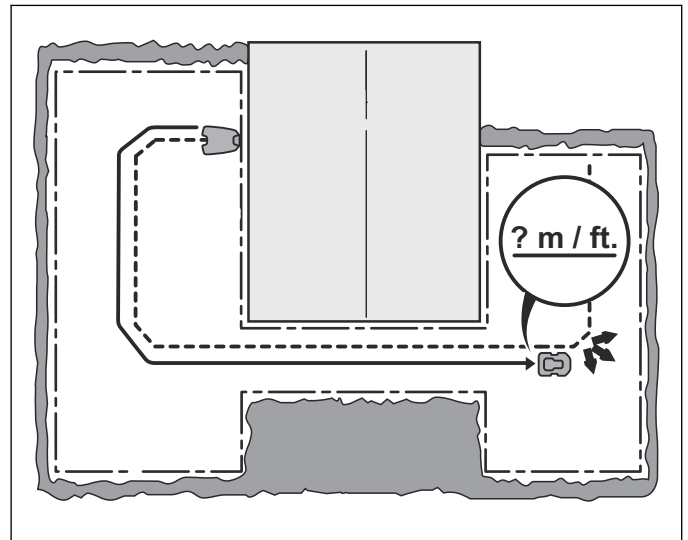

3.20.2.3 Area 1, 2 or 3 > How often?

How often the robotic lawnmower must be steered to the remote area is selected as a proportion of the total number of times it leaves the charging station. At all other times, the robotic lawnmower starts to mow at the charging station.

Select the percentage that corresponds to the size of the remote area relative to the total working area. If the remote area is for instance half of the total working area, 50% must be selected. A lower figure must be specified if the remote area is smaller. If more areas are used, take into account that the total figure cannot exceed 100%.

Compare with the examples in *Yard layout examples on page 39*.

Use the **number keys** to specify share as a percentage.

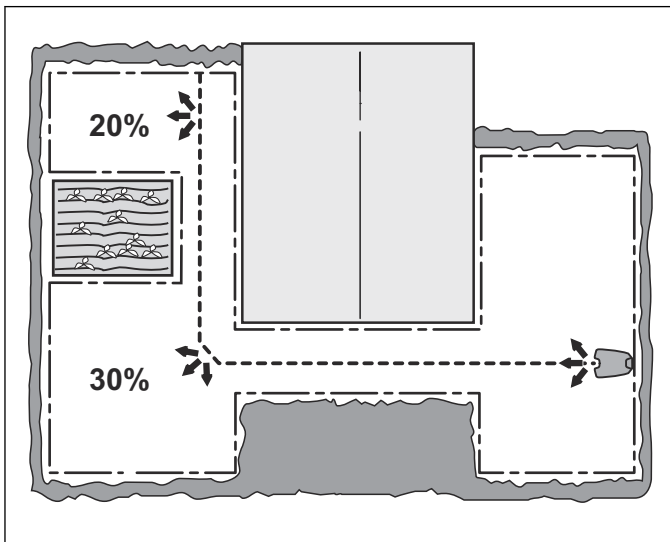

3.20.2.4 Area 1, 2 or 3 > Disable

Each area can be disabled and enabled without having to reenter the settings. Select *Disable* and press **OK**.

3.20.2.5 Area 1, 2 or 3 > More > Test

Testing selected settings can be seen as a natural part of the installation.

Using the *Test* function, the robotic lawnmower travels the farthest distance from the guide wire allowed by the selected corridor width.

3.20.2.6 Test: Area 1, 2 or 3

To test the selected settings:

1. Place the robotic lawnmower in the charging station.
2. Use the down and the right/left **arrow keys** to select the area to be tested from the *Lawn coverage overview* screen. Press **OK**.
3. Select *More* and press **OK**.
4. Select *Test* and press **OK**.
5. Press **START** and close the hatch.
6. The robotic lawnmower will now leave the charging station and begin following the guide wire toward the remote area. Check that the robotic lawnmower can follow the guide wire all along the required distance.
7. The test is approved when the robotic lawnmower can follow the guide wire to the required starting point without any problem.

3.20.2.7 How to measure the distance to a remote area

1. Park the robotic lawnmower in the charging station.
2. In the *Area 1, 2 or 3 > How far?* menu function, enter a distance which beyond any doubt exceeds the real figure. The maximum distance that can be entered is 500 metres.
3. Select *Area 1, 2 or 3 > More > Test* and press **OK**.
4. Press the **START** button and close the hatch.
5. Press **STOP** at the required position. The distance is now shown in the display. This figure can now be saved in *Area 1, 2 or 3 > How far?*

3.20.2.8 Area 1, 2 or 3 > More > Reset

An individual area setting can be reset to the factory setting using this function. To reset an area setting,

select *Area 1, 2 or 3 > More > Reset* using the left right **arrow keys** followed by **OK**.

3.20.3 Find charging station

The robotic lawnmower can be set to search for the charging station in one or more of the following three ways: Guide, Boundary loop and Charging station. The factory settings are set so that these 3 search options are automatically combined to find the charging station as quickly as possible but also with a minimum risk of tracks forming.

In very complex gardens e.g. with many areas joined by narrow passages, the amount of time required to find the charging station is decreased by carrying out a number of the manual settings outlined below.

The robotic lawnmower always starts the search for the charging station using an irregular search method.

When the robotic lawnmower still cannot find the charging station after a specific period of irregular searching, it also starts to search for the guide wires and after a further period also the boundary wire to follow one of them into the charging station instead. This time is specified in minutes and is known as delay time.

Example:

3 minute delay for Guide and 11 minutes for the boundary loop. The robotic lawnmower then searches irregularly for 3 minutes and then searches for the guide wires for 8 minutes. If it has not found a guide wire after this period, the robotic lawnmower now also searches for the boundary loop.

It is possible of course to specify the same delay time for both the guide wires and boundary loop, for instance 5 minutes. The robotic lawnmower then searches irregularly for 5 minutes and when it does not find the charging station, it continues to search either by following the guide wires or the boundary loop, depending on which one it reaches first.

In general a long delay time decreases the risk of tracks forming (the robotic lawnmower will find the charging station more often through irregular searches) but gives longer search times. A short delay time gives the opposite effect, i.e. short search times with increased risk of tracks forming along the guide wires and/or boundary wires.

3.20.3.1 Overview

This overview summarises the selected settings for each search method. To edit the settings for a method, select the method using left and right **arrow keys** followed by **OK**.

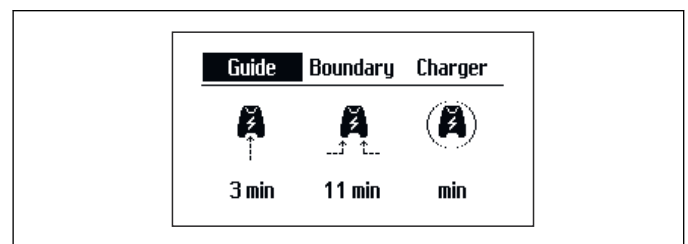

3.20.3.2 Guide

Use the **number keys** to enter the delay time.

The delay time is normally specified as a figure between 0 and 10 minutes.

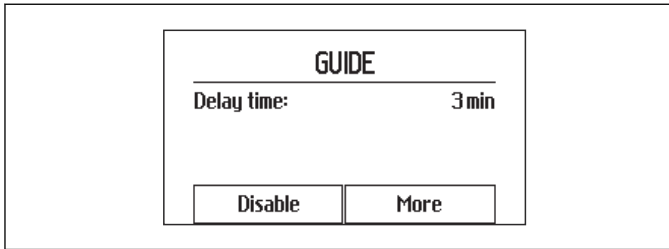

3.20.3.3 Guide > Disable / Enable

Normally the Guide method does not need to be deactivated even if there is no guide wire installed. However, to disable the Guide method, select *Disable* and press **OK**.

3.20.3.4 Guide > More > Test guide

Testing selected settings can be seen as a natural part of the installation.

1. Place the robotic lawnmower about 3 m from the guide wire, facing the wire.
2. The test function is found in *Installation > Find charging station > Guide*.
3. Select *More* and press **OK**.
4. Select *Test Guide*, and press **OK**.
5. Press **START** and close the hatch.
6. Check that the robotic lawnmower follows the guide wire all the way to the charging station and that it docks with the charging station. The test is approved only if the robotic lawnmower is able to follow the guide wire the entire distance to the charging station and docks at the first attempt. If the robotic lawnmower is unable to dock on the first attempt, it will automatically try again. The installation is not approved if the robotic lawnmower needs two or more attempts to dock with the charging station.

3.20.3.5 Guide > More > Reset

The specific settings for each method, *Guide* can be reset to factory settings.

1. To reset, select the method using the left and right **arrow keys** followed by **OK**.
2. Select *More*, then *Reset* and press **OK**.

3.20.3.6 Boundary loop

Use the **number keys** to enter the delay time.

This time is normally longer than for *Guide* as it is normally better if the robotic lawnmower follows the guide wire home to the charging station. The delay time is normally specified as a figure between 10 and 20 minutes but can be shorter if the guide wire is not installed and it is unlikely that the robotic lawnmower can find the charging station through an irregular search.

Note: If the robotic lawnmower passes a guide wire while following the boundary wire, it will stop searching

along the boundary wire and instead start to follow the guide wire into the charging station.

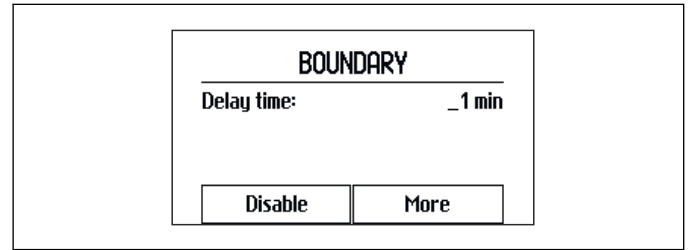

3.20.3.7 Boundary loop > Disable / Enable

If it is very inappropriate in the installation to follow the boundary loop, the Boundary method checkbox has to be deactivated. To disable the boundary method, select *Disable* and press **OK**.

3.20.3.8 Boundary > More > Test right / Test left

Testing selected settings can be seen as a natural part of the installation. Using the Test function, the robotic lawnmower travels the maximum distance from the wire defined by the selected corridor width.

1. Place the robotic lawnmower about 3 m from the boundary wire, facing the wire.
2. The test function is found in *Installation > Find charging station > Boundary*.
3. Select *More* and press **OK**.
4. Select *Test right/Test left*, and press **OK**.
5. Press **START** and close the hatch.
6. Check that the robotic lawnmower follows the guide wire all the way to the charging station and that it docks with the charging station. The test is approved only if the robotic lawnmower is able to follow the guide wire the entire distance to the charging station and docks at the first attempt. If the robotic lawnmower is unable to dock on the first attempt, it will automatically try again. The installation is not approved if the robotic lawnmower needs two or more attempts to dock with the charging station.

Normal causes as to why the robotic lawnmower cannot follow the wire are that obstacles close to the wire have not been isolated or that the guide wire has not been laid at an angle on a steep slope. Check that the charging station, the boundary wire and the guide wire are installed in accordance with the instructions in *Laying the boundary wire on page 16*, in *Plan where to lay the boundary wire on page 13* and in *Laying and connecting the guide wire on page 18*.

3.20.3.9 Boundary > More > Reset

The specific settings for each method, *Boundary* can be reset to factory settings.

1. To reset, select the method using the left and right **arrow keys** followed by **OK**.
2. Select *More*, then *Reset* and press **OK**.

3.20.3.10 Charging station range

There may be reasons to reduce the range of the charging station in rare cases. It may be necessary if for instance the charging station is placed close to a bush

or wall which prevents the robotic lawnmower from docking with the charging station despite making contact with the charging station's signals. In these cases, it is normally better to move the charging station, but if this is not possible, the range of the charging station can be reduced. The charging station range has three different intervals: *Max*, *Mid*, *Min*. The factory setting is *Max*.

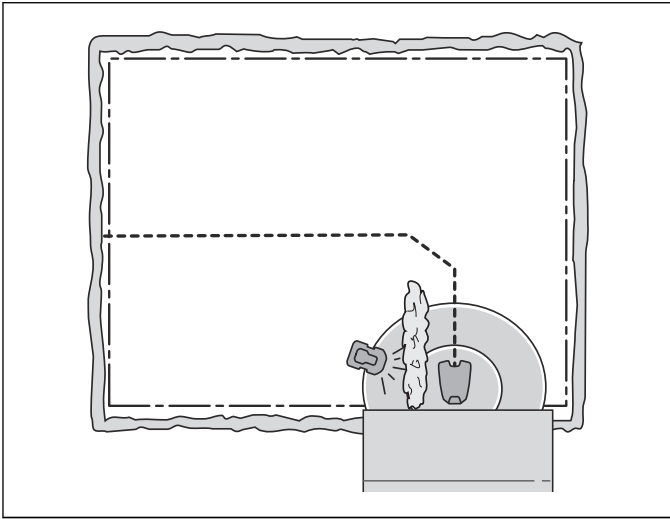

Note: The charging station's range must only be reduced in exceptional cases. It is normally better to move the charging station to a better place in the working area.

3.20.4 Advanced

Under the *Advanced* heading, there are more settings relating to the behaviour of the robotic lawnmower. The settings in this menu are only required if additional control of the lawnmower is needed for example in complex gardens. The factory settings are selected in a way that should suit most working areas.

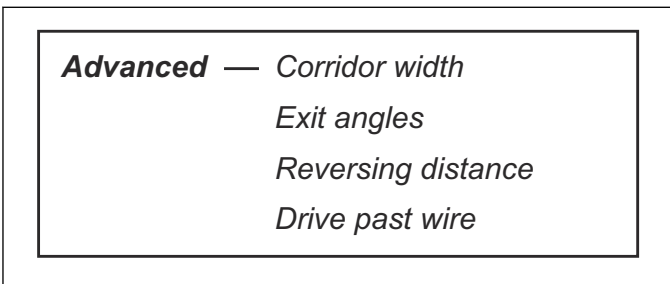

3.20.4.1 Corridor width

The corridor width is a measure of how far from the guide wire/boundary wire the robotic lawnmower is allowed to run when it follows this to and from the charging station. The area beside the wire, which the robotic lawnmower uses, is called the Corridor.

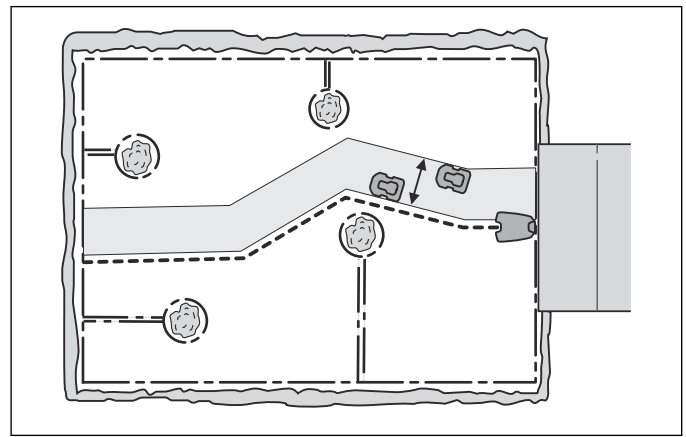

The aim of operating at varying distances from the wire is to reduce the risk of tracks forming. Therefore it is recommended to select the widest corridor possible.

The robotic lawnmower adjusts the corridor when following along a guide wire. The inbuilt automatic mechanism allows the robotic lawnmower to vary the distance from the wire depending on where in the working area it is located. It automatically makes the corridor narrower in narrow passages for instance.

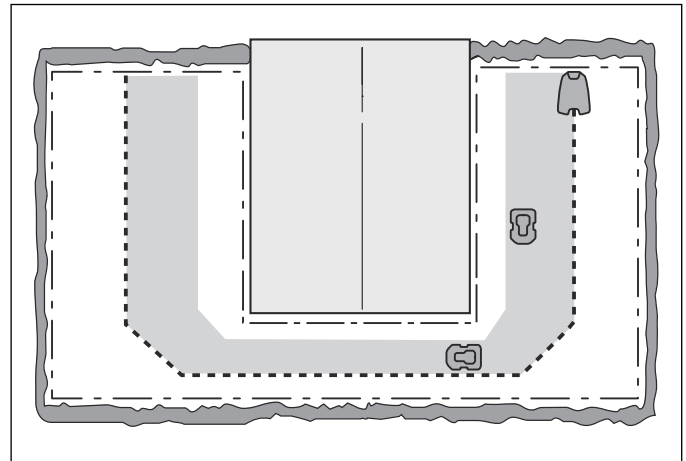

The default settings can be used for many working areas. In more complex gardens operation can be improved by carrying out some of the manual settings below.

3.20.4.2 Corridor width > Boundary

The boundary corridor width is specified in intervals from 1-9. The first number in the interval specifies the shortest distance to the boundary loop and the second number the longest distance.

The distance the robotic lawnmower maintains from the boundary loop varies depending on the layout of the working area.

Use the **number keys** to specify the required interval.

The factory setting is 3-6.

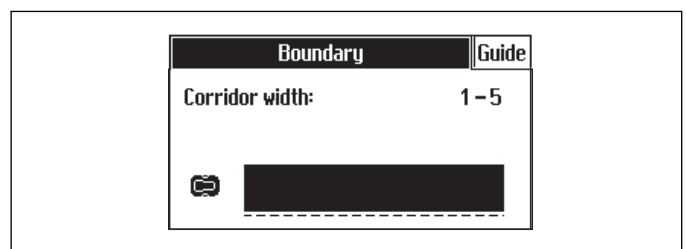

3.20.4.3 Corridor width > Guide

The guide corridor width is adjusted automatically. Only in rare occasions manual settings need to be entered. The guide corridor width can be set between 0 and 9.

If guide corridor width is set to 0, the robotic lawnmower will straddle the guide wire. This means that the robotic lawnmower runs right over the guide wire.

Use the **arrow keys** to specify the required value.

The factory setting is 9.

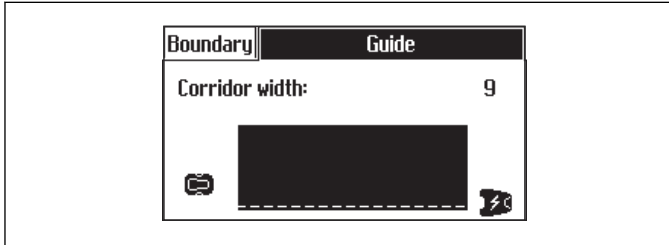

3.20.4.4 Exit angles

Normally the robotic lawnmower leaves the charging station in a direction within the 90°-270° exit sector. By changing the exit angles, it makes it easier for the robotic lawnmower to reach the working areas.

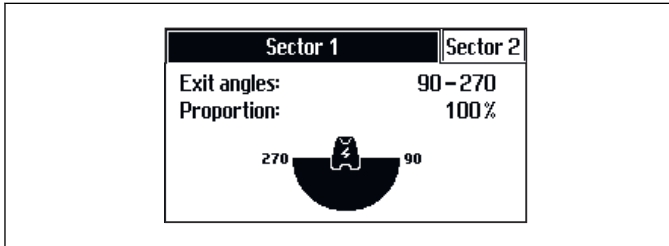

3.20.4.5 Exit angles > Sectors

The robotic lawnmower can be set for 1 or 2 exit sectors. If the charging station is placed in a passage, 2 exit angles, for instance 70° - 110° and 250° - 290°, can be used.

When 2 exit angles are used, there is a need to also specify how often the robotic lawnmower must leave the charging station in *Sector 1*. This is done using the *Proportion* function by initially specifying a percentage.

For instance the percentage of 75 % means that the robotic lawnmower leaves the charging station in *Sector 1* on 75% of the times and 25% of the times in *Sector 2*.

Use the **number keys** to specify the required angles in degrees for the sectors and proportion as a percentage.

3.20.4.6 Reversing distance

This functions allows you to control how far the robotic lawnmower reverses out from the charging station before it starts mowing. This is a useful function for instance if the charging station is placed way in under a veranda or in another limited space area.

Use the **number keys** to specify the required reverse distance in centimetres. The factory setting is 60 cm.

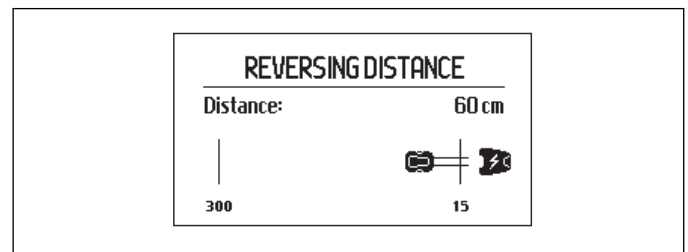

3.20.4.7 Drive past wire

The front of the robotic lawnmower always passes the boundary wire by a specific distance before the mower turns around. The default distance is 32 cm, but this can be changed if required. A figure between 25 and 50 can be selected.

Note that the distance given is only an approximate value and should be regarded as a guide. In reality, the actual distance the robotic mower passes the boundary wire can vary.

Specify the number of centimetres you want the robotic lawnmower to pass the boundary wire and press **OK**.

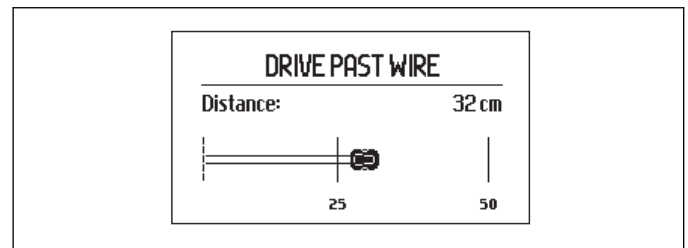

3.21 Settings

This selection allows you to carry out changes to the robotic lawnmower's general settings.

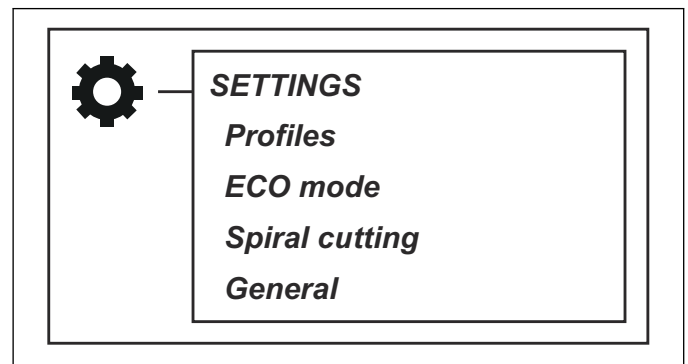

3.21.1 Profiles

Only applicable to Automower® 315 and Automower® 315X.

With the function *Profiles*, different sets of user settings can be saved. Up to 3 different profiles can be stored. The unique connection between the mower and the charging station is saved in the profiles. This means that the settings can be easily stored and reused if the robotic lawnmower for example will be used in different gardens. This enables up to 3 charging stations to be connected to the same robotic lawnmower.

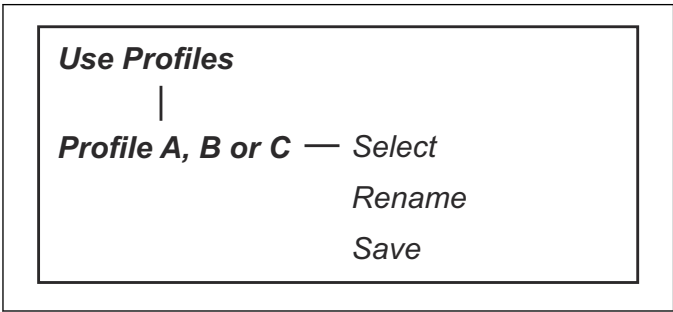

3.21.1.1 Save settings to a Profile

First make the settings in the mower that will be stored in the profile.

1. Select *Use Profiles* and press **OK**.
2. Select the profile to be stored, move the cursor with the up and down **arrow keys** and press **OK**.
3. Select *Save* and press **OK**, followed by **arrow key** left and **OK**. All user settings are now stored in the selected profile.

If settings that are not stored to the profile are made, the symbol * is shown next to the profile name.

3.21.1.2 Use a Profile

To activate and use a profile, and thus use the saved settings, the following action must be taken.

1. Select the profile to activate and press **OK**.
2. Select *Select* and press **OK**.

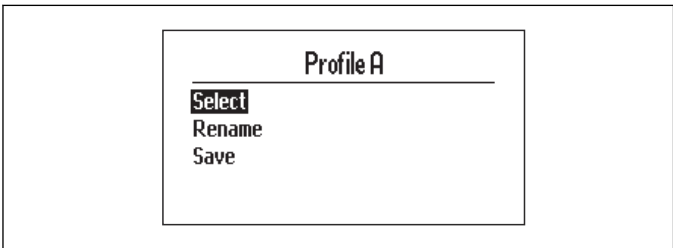

The robotic lawnmower will now use the settings stored in the profile.

3.21.1.3 Change the name of a Profile

The names of the profiles can be changed, to make it easier to remember what settings are stored in the respective profile.

1. Select the profile name to be changed and press **OK**.
2. Select *Rename* and press **OK**.
3. Move the cursor with the **arrow keys** and press **OK** to select a letter. Press **BACK** to save the new name.

The names of the profiles will be shown in the menu *Settings - Profiles*. The name of the selected profile is also visible on the start screen.

3.21.1.4 To connect a new charging station to the robotic lawnmower

1. First save a profile to be used with the original charging station.
2. Then set the mower in the new charging station that will be connected to the mower.
3. Select *New loop signal*, see *Advanced on page 26*

4. Save a profile for the new charging station.

To use the robotic lawnmower in the original charging station, the first profile must now be selected. To use the robotic lawnmower in the new charging station, that profile must be selected.

3.21.2 ECO mode

This function automatically turns off the signal in the boundary loop, the guide wires and the charging station when the robotic lawnmower is not mowing, i.e. when the lawnmower is charging or is not allowed to mow due to timer settings.

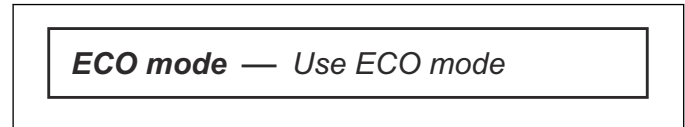

ECO mode is suitable to use where there is other wireless equipment not compatible with the robotic lawnmower e.g. certain hearing loops or garage doors.

When *ECO mode* is activated, the indicator lamp in the charging station flashes green. *ECO mode* means that the robotic lawnmower can only be started in the charging station and not out in the working area.

In *ECO mode*, it is very important to always press the **STOP** button before removing the robotic lawnmower from the charging station. It is otherwise not possible to start the robotic lawnmower. If the lawnmower has been removed by mistake without first pressing the **STOP** button, the lawnmower must be placed back in the charging station and the **STOP** button pressed. Only then can the robotic lawnmower be started inside the working area.

Select *ECO mode* and press **OK** to activate *ECO mode*.

Note: Always press the **STOP** button before removing the robotic lawnmower from the charging station. In *ECO mode* the robotic lawnmower otherwise can not be started inside the working area.

3.21.3 Spiral cutting

If the robotic lawnmower enters an area where it senses the grass is longer than average, it can change the movement pattern. It can then mow in a spiral pattern to faster cut the area of longer grass.

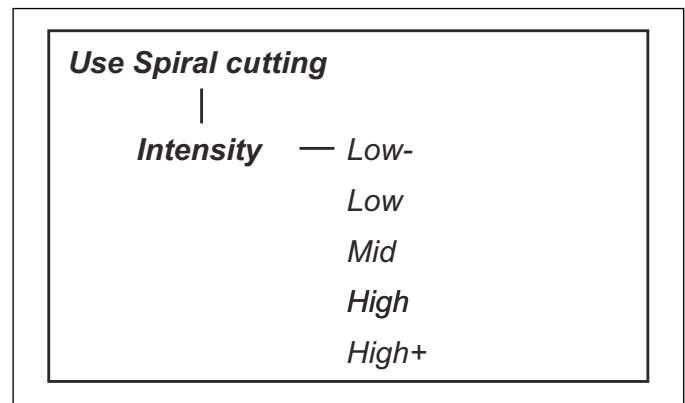

Spiral cutting is activated by default, uncheck the box to deactivate.

The level of intensity can be adjusted to set how much over the average height the grass has to be for spiral cutting to begin. *Low- / Low* sensitivity means that spiral cutting begins less often. *High / High+* sensitivity means that spiral cutting begins more often.

In order to minimize the risk for lawn wear in steep slopes, spiral cutting does not start in slopes steeper than 15%.

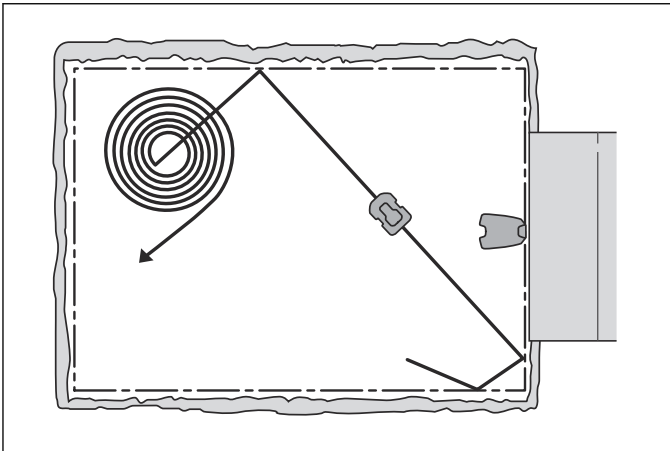

3.21.4 Slope control

In order to reduce lawn wear near boundary wire in slopes, the product avoids reversing when driving downhill. When approaching the boundary wire it therefore either bounces away or makes a U-turn. *Slope control* is activated by default. Uncheck the box to deactivate.

3.21.5 General

Set language and time or reset user settings to factory default.

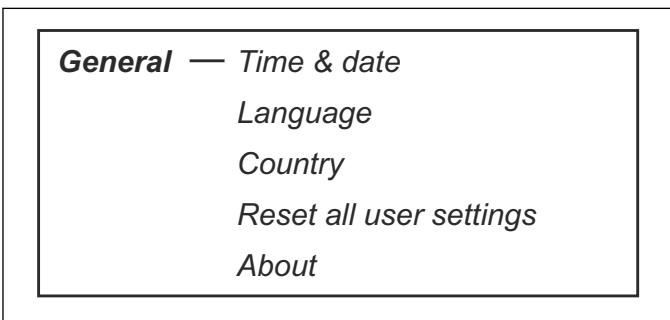

3.21.5.1 Time & Date

This function allows you to set current time and date and required formats.

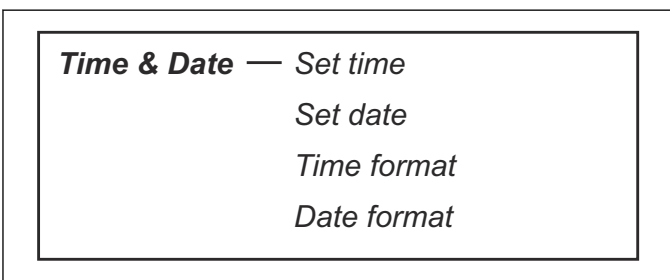

- **Set time:** Enter the correct time and press **OK** to exit.
- **Set date:** Enter correct date and press **OK** to exit.
- **Time format:** Place the cursor at the required time format: 12h 24h. Press **OK** to exit.

- **Date format:** Place the cursor at the required date format:
 YYYY-MM-DD (year-month-day)
 MM-DD-YYYY (month-day-year)
 DD-MM-YYYY (day-month-year)
 Exit by pressing **OK**.

3.21.5.2 Language

Set language with this function.

To select language: Place the cursor at the required language and press **OK**.

3.21.5.3 Country

With this function you can select in what country the robotic lawnmower will work.

Place the cursor at the required country and press **OK**.

3.21.5.4 Reset all user settings

This function allows you to reset the robotic lawnmower to the factory default settings.

The following settings are however not altered:

- Security level
 - PIN code
 - Loop signal
 - Messages
 - Date & Time
 - Language
 - Country
1. Select *Reset all user settings* in the menu and press **OK**.
 2. Confirm by pressing **OK**.

3.21.5.5 About

The *About* menu displays information about the robotic lawnmower's serial number and different software versions.

3.22 Accessories

Settings for accessories mounted on the mower can be made in this menu.

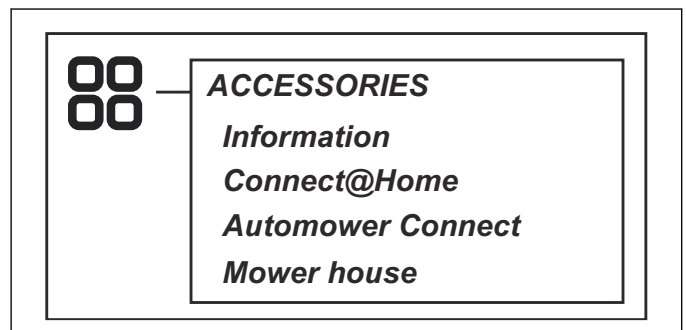

3.22.1 Information

This menu handles accessories mounted on the mower. Contact Husqvarna customer service for more information on available accessories.

3.22.2 Information

Only applicable to Automower® 310 and Automower® 315.

The Automower® Connect app provides two modes of connectivity: Long-range cellular connectivity and Short-range Bluetooth® connectivity. The short-range interaction with the product is called Automower® Connect@Home. When pairing between the product and app has been confirmed, you have access to the menus and functions as long as you are within short-range (Bluetooth).

3.22.3 Automower Connect

Automower Connect is included in Automower® 315X, and available as an accessory for Automower® 310/315.

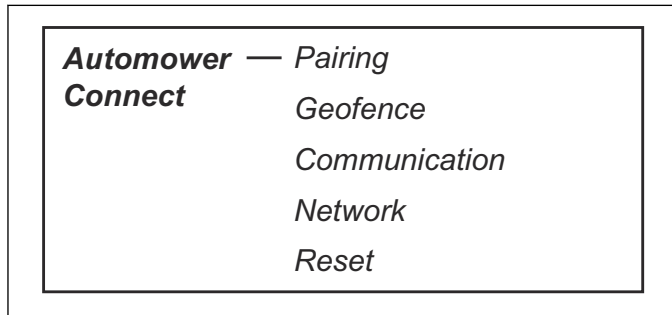

Automower Connect brings the mower's menu system to your smartphone, making it easy to read and change the mower settings remotely. Through this smartphone mobile application, you can receive your Automower's current status and send commands to the mower from anywhere in the world. In case of theft, you will get an alarm and be able to track your mower's position.

Download the Automower Connect app from AppStore or GooglePlay. Once you have downloaded the app, you can specify an e-mail address and a password to create an Automower Connect account. You will receive a validation e-mail to the e-mail address you specified. Follow the instructions in the e-mail within 24 hours to validate your account. If not validated within 24 hours, you will have to create your account again.

3.22.3.1 Main menu

The main menu in Automower Connect consists of:

- **Status:** Shows detailed robotic lawnmower status and you can send commands to the robotic lawnmower.
- **GeoFence:** The house pin on the map shows the starting point of the robotic lawnmower. A circle around the house pin indicates the radius of the GeoFence. The second pin on the map shows the actual position of the robotic lawnmower. You can track the movement of the robotic lawnmower with this feature, e.g. in case of theft. Click the pin to show the robotic lawnmower coordinates.
- **Settings:** Display and change all available settings in the mower menu, with the exception of the security settings.

3.22.3.2 My mowers

When choosing *My mowers* you can manage all the robotic lawnmowers coupled to your account as well as add new ones.

3.22.3.3 Pairing

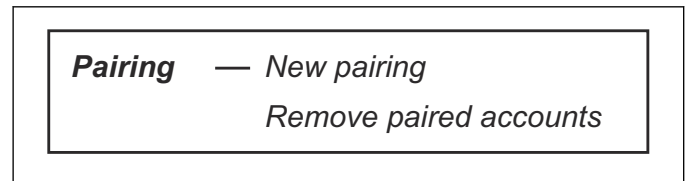

When the account has been created in the app you can pair your robotic lawnmower and smartphone. When the app prompts you to do so, enter the 6-digit code shown on the robotic lawnmower display after selecting the function *Accessories > Automower Connect* (mower PIN required) > *Pairing > New pairing*. Also enter the name of the mower into the app.

3.22.3.4 GeoFence

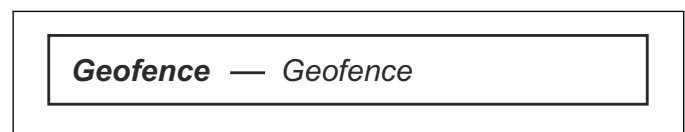

Before GeoFence can be used, its center point (origin) and sensitivity must be set. This can only be done from the mower menu.

Place the mower centrally in your yard. Select *Accessories > Automower Connect* (robotic lawnmower PIN required) > *GeoFence*. Activate the function by selecting *Activate GeoFence* and pressing **OK**. Select *New center point* to set the origin for GeoFence. GeoFence sensitivity can be changed to suit your yard. Sensitivity can be set to *Low*, *Medium* or *High*. The higher the sensitivity, the easier the alarm is activated. If the alarm is activated too easily, you should select a lower setting for the GeoFence sensitivity.

When putting the robotic lawnmower into storage for a long period, such as during the winter, we recommend turning off the main switch. With the GeoFence function activated, you will need the PIN code in order to turn off the robotic lawnmower. Once the main switch has been turned off, the Connect function will stay active for another 12 hours. After that it will not be possible to communicate with the robotic lawnmower and the GeoFence function will not be active.

3.22.3.5 Communication

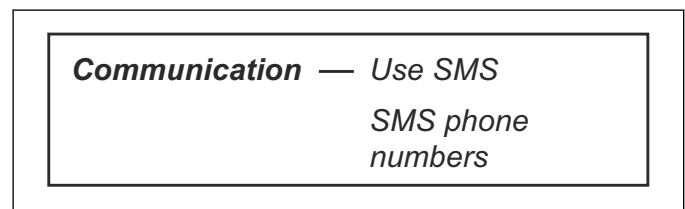

Use SMS

The SMS function must be activated from the mower menu before it can be used. Select *Accessories > Automower Connect* (robotic lawnmower PIN required) > *Communication > Use SMS*.

SMS phone numbers

The telephone numbers to the mobiles allowed to communicate via SMS must be entered into the list of SMS numbers. The numbers must be entered with their country codes, e.g. (+)46701234567. Use the Test-SMS function to verify the specified telephone number. A text will then be sent to all the telephone numbers on the list. The list can have up to three numbers.

With the SMS function activated, an SMS will be sent to all the telephone number in the list if the mower is found outside the GeoFence. Certain information can also be retrieved from the robotic lawnmower by sending it an SMS. An SMS with the command "GET GPS INFO" to the mower will give information concerning its position, the origin of GeoFence and its radius together with the GPS signal strength. Note that the telephone of the sender must be specified in the robotic lawnmower. A maximum of 10 SMS per month can be sent from the mower.

3.22.3.6 Network

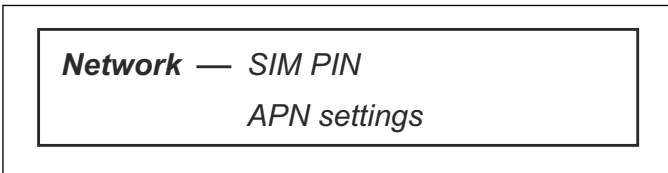

SIM PIN

This menu is only applicable if you use a non-Husqvarna SIM.

APN settings

The robotic lawnmower must specify APN settings to be able to use and send data via the mobile net. Settings for Husqvarna SIM is default.

3.22.3.7 Reset

If you choose the function *Reset* you will then need to confirm that you want to *Proceed with reset of Automower® Connect settings*.

3.22.4 Mower house

This function handles the settings for the mower house.

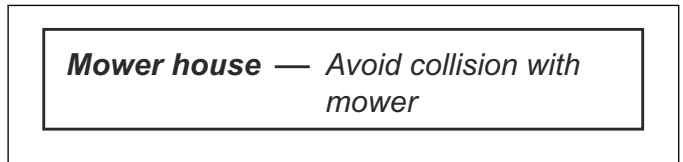

3.22.4.1 Headlights

It is possible to choose schedule for the headlights. The available options are: *Always ON*, *Evening only*, *Evening & night*, and *Always OFF*.

3.22.4.2 Headlights

In this menu it is possible to enable/disable that the product should flash with the headlights in fault mode. The product then clearly shows that it needs attention from a far distance, and even by night.

3.22.5 Mower house

This function handles the settings for the mower house.

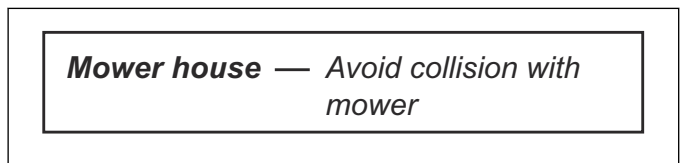

3.22.5.1 Avoid collisions with mower house

If this option is selected, the wear on the mower and the house is reduced, but it can result in more uncut grass around the charging station.

3.23 Menu structure overview

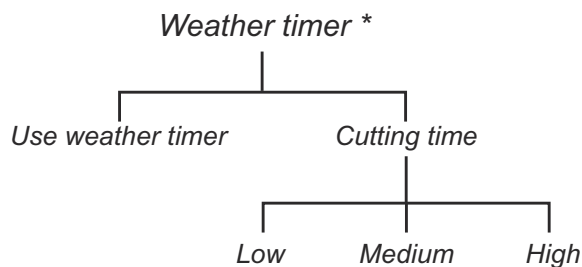
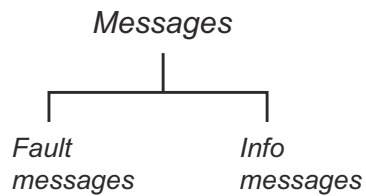
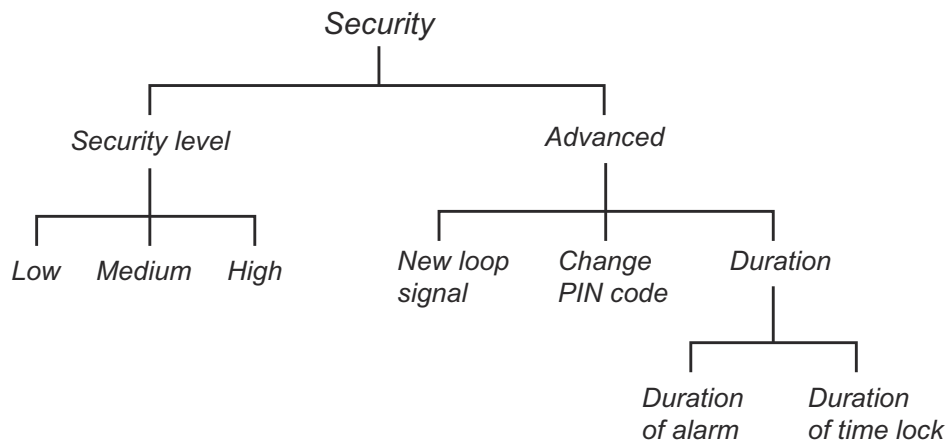
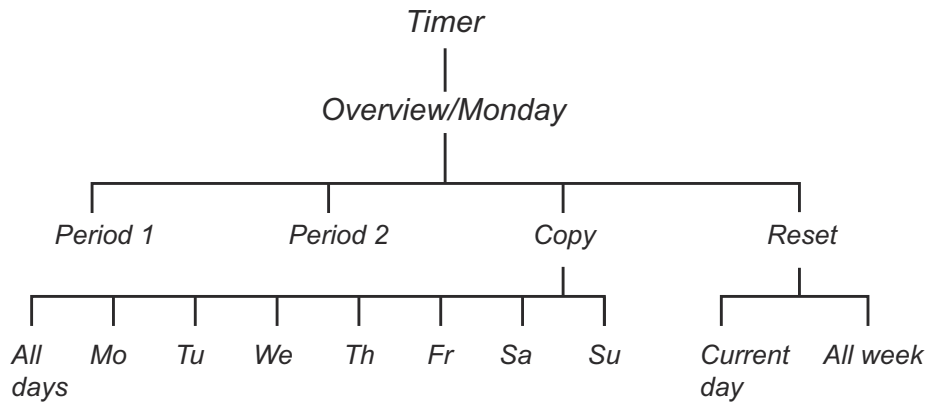

* Automower 315/315X

3.24 Menu structure overview

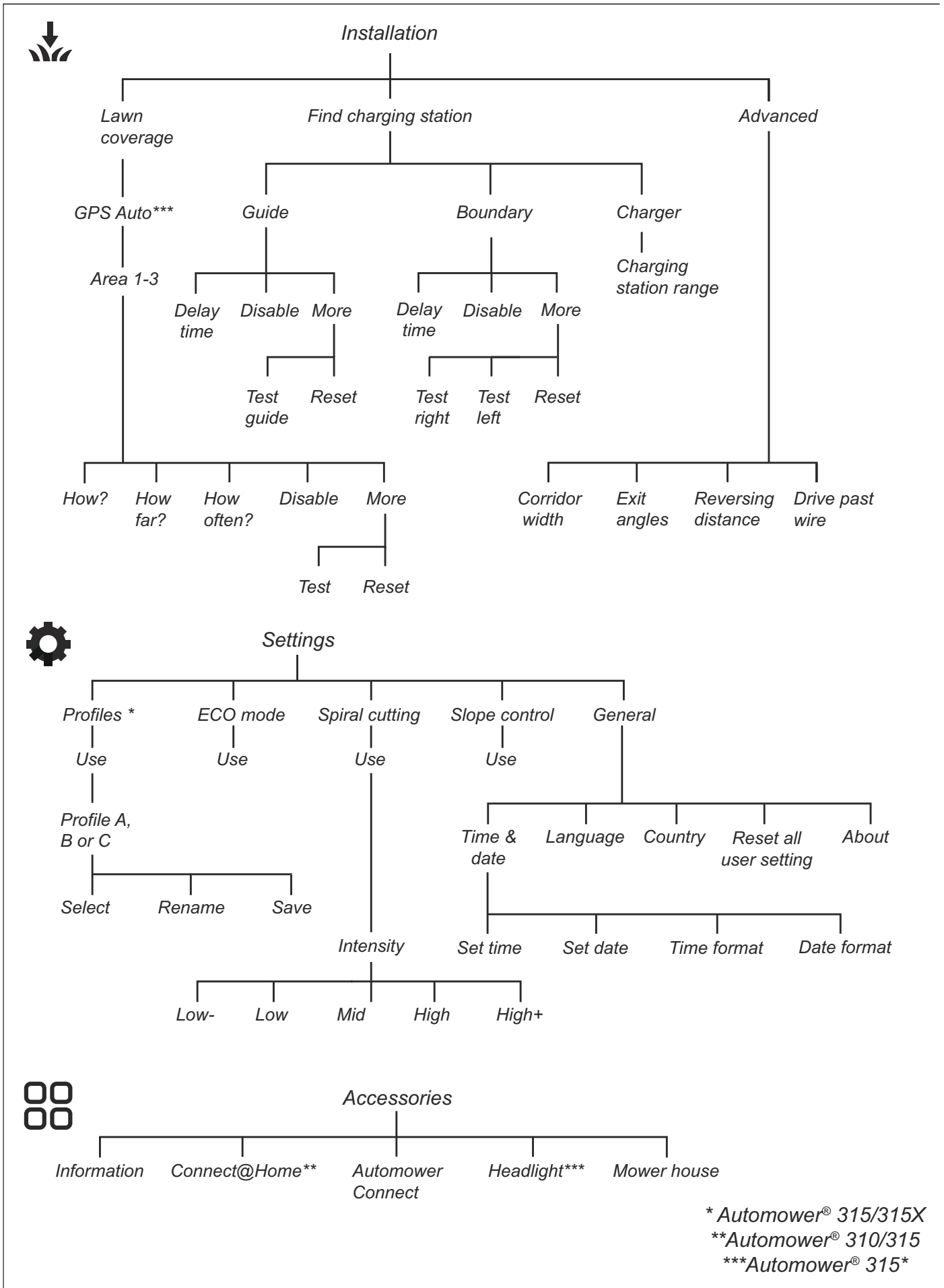

* Automower® 315/315X
 **Automower® 310/315
 ***Automower® 315*

3.25 Yard layout examples

Different layouts require different settings. Adapting the robotic lawnmower's settings according to the shape of the lawn makes it easier for the robotic lawnmower to frequently reach all parts and therefore achieve a perfect mowing result. The following pages outline a number of layout examples with installation proposals and settings.

The recommended timer settings in the following examples are applicable to Automower® 310/315/315X unless otherwise stated. There is more installation help on www.husqvarna.com.

Note: The default settings for the robotic lawnmower have been chosen to work in as many different gardens as possible. The settings only need to be adjusted when special installation conditions exist.

3.25.1 Open and level area

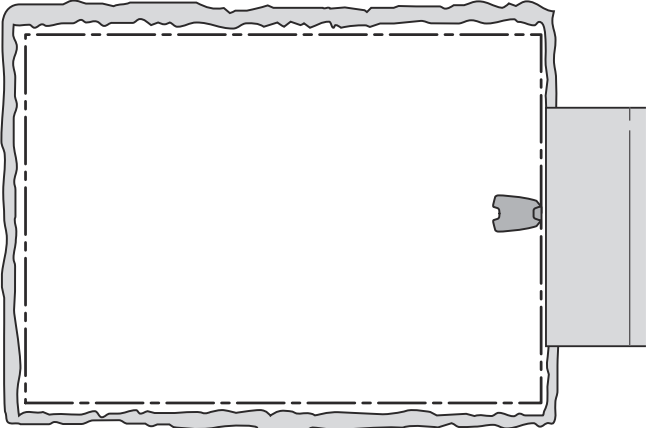
Area	150 m²	
Timer	Automower® 310 08:00 - 14:00, Monday, Wednesday, Friday	
	Automower® 315/315X 08:00 - 13:00, Monday, Wednesday, Friday	
Lawn coverage	Factory setting	
Remarks	<p>The timer should be used to prevent the grass looking trampled since the area is less than the maximum capacity of the robotic lawnmower.</p> <p>As the area is open and uncomplicated there is no need for a guide wire in this installation.</p>	

3.25.2 A number of islands and a 35% slope

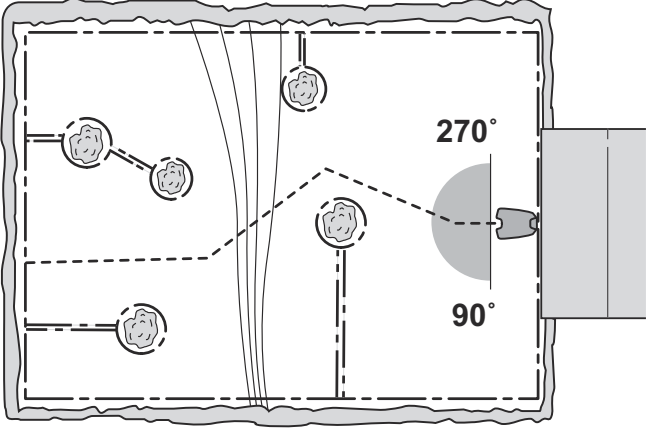
Area	500 m²	
Timer	Automower® 310 08:00 - 18:30, Monday to Sunday	
	Automower® 315/315X 08:00 - 16:30, Monday to Sunday	
Lawn coverage	Factory setting	
Find charging station	Factory setting	
Remarks	<p>Place the charging station in the lower part of the working area. Lay the guide wire at an angle over the steep slope. Make sure guide wire is laid according to recommendations in <i>Laying and connecting the guide wire on page 18</i></p>	

3.25.3 L-shaped garden with a couple of islands and the charging station installed in the narrow area

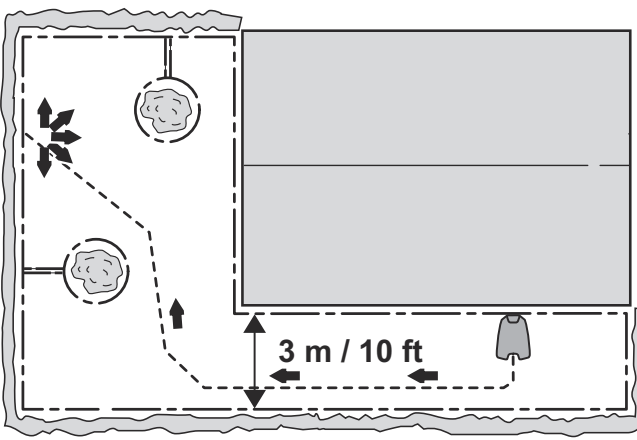
Area	800 m²	 The diagram shows an L-shaped garden layout. A dashed line represents the guide wire path. A charging station is located in the narrow vertical section of the 'L'. A dimension line indicates a width of 3 m / 10 ft for this narrow section. There are two circular islands in the horizontal section of the 'L'. A tree is shown on the left side of the horizontal section.
Timer	Automower® 310 07:00 - 24:00, Monday to Sunday Automower® 315/315X 08:00 - 22:00, Monday to Sunday	
Lawn coverage	Area 1: How? Guide How far? X m How often? 40%	
Find charging station	Factory setting	
Remarks	The <i>Lawn coverage</i> (How often?) for <i>Guide</i> must be specified as a value corresponding to the largest part of the working area as most of the working area can easily be reached by the robotic lawnmower following the guide wire out from the charging station. Make sure guide wire is laid according to recommendations in <i>Laying and connecting the guide wire</i> on page 18.	

3.25.4 U-shaped garden linked with a narrow passage

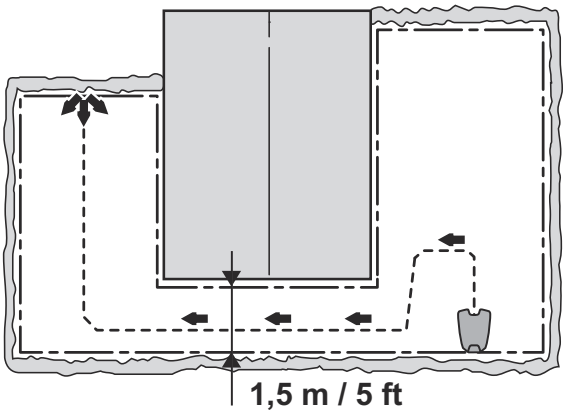
Area	1 000 m²	 The diagram shows a U-shaped garden layout. A dashed line represents the guide wire path. A charging station is located in the narrow passage at the bottom of the 'U'. A dimension line indicates a width of 1,5 m / 5 ft for this passage. There are two circular islands in the top horizontal section of the 'U'. A tree is shown on the left side of the top horizontal section.
Timer	Automower® 310 06:00 - 24:00, Monday to Sunday Automower® 315/315X 07:00 - 24:00, Monday to Saturday	
Lawn coverage	Area 1: How? Guide How far? X m How often? 40%	
Find charging station	Factory setting	
Remarks	The guide wire must be placed along the narrow passage to ensure that the robotic lawnmower can with ease locate the charging station from the left hand side of the working area. 40% is selected for <i>Lawn coverage</i> , <i>How often?</i> as the left hand area is nearly half of the total area. Make sure guide wire is laid according to recommendations in <i>Laying and connecting the guide wire</i> on page 18.	

3.25.5 Unsymmetrical working area with a narrow passage and a number of islands

Area	800 m²		
<i>Timer</i>	Automower® 310 07:00 - 24:00, Monday to Saturday		
	Automower® 315/315X 08:00 - 22:00, Monday to Saturday		
<i>Lawn coverage</i>	Factory setting		
<i>Find charging station</i>	Factory setting		
Remarks	<p>The guide wire must be placed along the narrow passage to ensure that the robotic lawnmower can with ease locate the charging station from the right hand side of the working area. As the right hand area is only a small part of the working area, the <i>Lawn coverage</i> factory settings can be used. Make sure guide wire is laid according to recommendations in <i>Laying and connecting the guide wire</i> on page 18.</p>		

3.25.6 3 areas linked with two narrow passages

Area	800 m²		
<i>Timer:</i>	Automower® 310: 07:00 - 24:00, Monday to Saturday		
	Automower® 315/315X: 08:00 - 22:00, Monday to Saturday		
<i>Lawn coverage</i>	Area 1:	Area 2:	
	<i>How?</i> Guide	<i>How?</i> Guide	
	<i>How far?</i> X m	<i>How far?</i> X m	
	<i>How often?</i> 25 %	<i>How often?</i> 25 %	
Remarks	<p>As the working area contains three areas linked by two narrow passages, <i>Lawn coverage</i> must be used to create several areas to obtain an even mowing result across the entire working area. Make sure guide wire is laid according to recommendations in #.</p>		

3.25.7 A secondary area

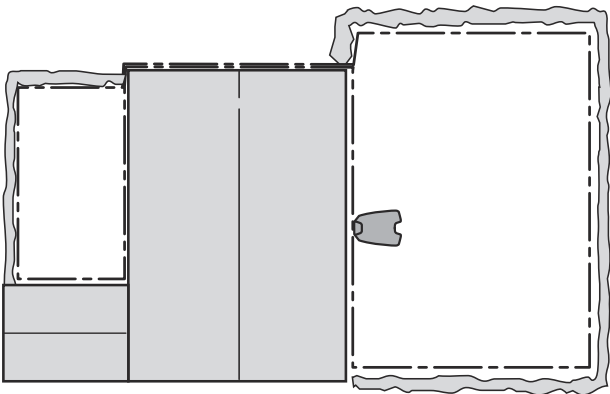
Area	500 + 100 m²	 A schematic diagram showing a central grey rectangular area. To its left is a smaller grey rectangle. To its right is a larger white rectangular area with a dashed border, representing a cut. A grey door-like shape is attached to the right side of the dashed area. The entire diagram is enclosed in a light blue, irregular border.
<i>Timer</i>	Automower® 310: 08:00 - 20:30, Monday, Tuesday, Thursday, Friday, Saturday	
	Automower® 315/315X: 08:00 - 18:30, Monday, Tuesday, Thursday, Friday, Saturday	
<i>Lawn coverage</i>	Factory setting	
<i>Find charging station</i>	Factory setting	
Remarks	The secondary area is cut using the <i>Secondary area</i> mode on Wednesday and Sunday. As the area is open and uncomplicated there is no need for a guide wire in this installation.	

4 Operation

4.1 Main switch



WARNING: Read the safety instructions carefully before you start your robotic lawnmower.



WARNING: Keep your hands and feet away from the rotating blades. Never put your hands or feet close to or under the machine when the motor is running.



WARNING: Never use the robotic lawnmower when persons, especially children, or pets, are in the cutting area.

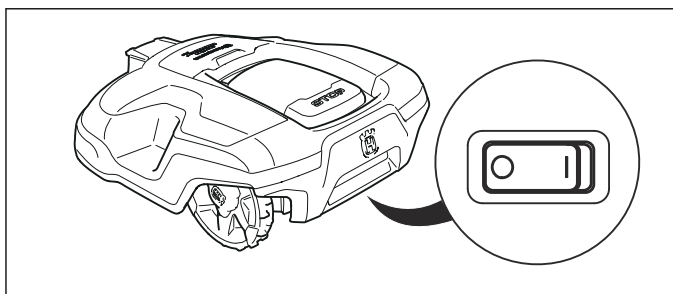

- Set the **Main switch** in the *1* position to start the robotic lawnmower.
- Set the **Main switch** in the *0* position when the robotic lawnmower is not in use or if any work, inspection or maintenance is being carried out.

When the main switch is set in the *0* position the motors on the robotic lawnmower cannot start.

4.2 Start

1. Press the **STOP** button to open the hatch.
2. Set the main switch to position *1*.
3. Enter the PIN code.
4. Press the **START** button.

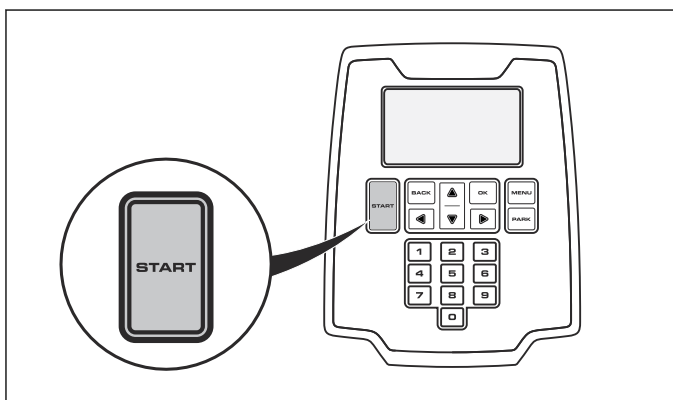

5. Select the desired operating mode. See *Operating mode - Start on page 43*.
6. Close the hatch within 10 seconds.

If the robotic lawnmower is parked in the charging station, it will only leave the charging station when the battery is fully charged and if the timer is set to allow the mower to operate.

Note: Always press the **START** button before closing the hatch to start the robotic lawnmower. If the **START** button is not pressed, a message beep is heard and the robotic lawnmower will not start. Before the blade disc starts a warning beep can be heard consisting of 5 short beeps for 2 seconds.

4.3 Operating mode - Start

When the **START** button has been pressed the following operation selections can be selected.

- Main area
- Secondary area
- Override timer
- Spot cutting (Automower® 315/315X)

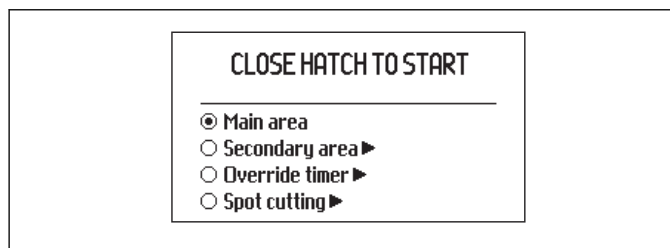

4.3.1 Main area

Main area is the standard operating mode where the robotic lawnmower mows and charges automatically.

4.3.2 Secondary area

When mowing secondary areas *Secondary area* setting must be used. Selecting *Secondary area* will cause the robotic lawnmower to mow until the battery is empty.

If the robotic lawnmower charges in the *Secondary area* mode, it will fully charge, drive out about 50 cm and then stop. This indicates that it is charged and ready to start mowing.

If the main working area has to be cut after charging, it is recommended to switch the operation selection to *Main area* before placing the robotic lawnmower in the charging station.

4.3.3 Override timer

Any timer settings can be temporarily overridden by selecting *Override timer*. It is possible to override the timer for 24 h or 3 days.

4.3.4 Spot cutting (Automower® 315/315X)

Spot cutting means that the robotic lawnmower will work in a spiral pattern in order to cut the grass in the area where it was started. When this is done, the robotic lawnmower will automatically switch to *Main area* or *Secondary area*.

This function is useful for quickly mowing an area where the grass has been mown less than in other parts of the garden.

The *Spot cutting* function is activated with the **START** button. You can select how the robotic lawnmower should continue to work once mowing is finished by

pressing right **arrow key** and then specifying *On Main area* or *On Secondary area*.

4.4 Operating mode Park

When the **PARK** button is pressed the following operation selections can be chosen.

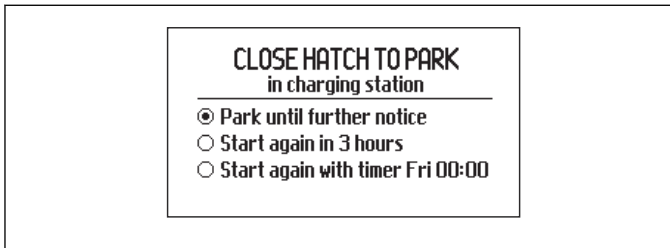

4.4.1 Park until further notice

The robotic lawnmower stays in the charging station until another operating mode is selected by pressing the **START** button.

4.4.2 Start again in 3 hours

The robotic lawnmower stays in the charging station for three hours and then automatically returns to normal operation. This operation selection is suitable when there is a need to pause operation, e.g. for temporary irrigation or for games on the lawn.

4.4.3 Start on next timer

The robotic lawnmower stays in the charging station until the next Timer setting permits operation. This operation selection is suitable if one wishes to cancel an ongoing mowing cycle and allow the robotic lawnmower to stay in the charging station until the next day.

4.5 Stop

1. Press the **STOP** button on top of the robotic lawnmower.

The robotic lawnmower stops and the blade motor stops.

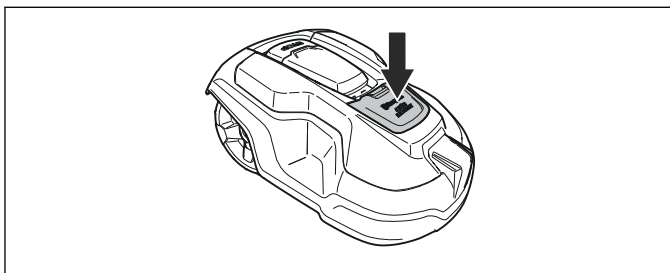

4.6 Switch off

1. Press the **STOP** button on top of the robotic lawnmower.
2. Set the **Main switch** to position 0.

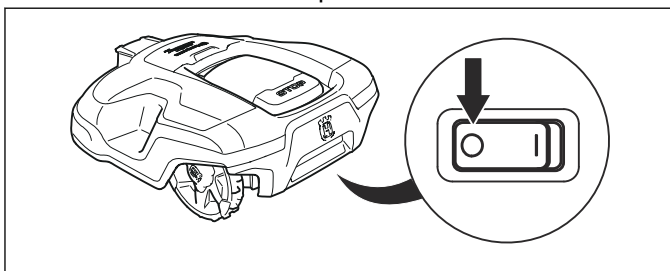

WARNING: Always switch off the robotic lawnmower using the main switch if it requires maintenance, or if the robotic lawnmower must be moved outside the working area.

4.7 Timer and Standby

Use the timer function (see *Timer on page 24*) to avoid a duntrodden lawn.

4.7.1 Standby

The robotic lawnmower has an inbuilt standby period according to the Standby time table. The standby period provides for instance a good opportunity to water or play games on the lawn.

Model	Standby time, hours per day
Automower® 310	min. 6
Automower® 315	min. 2

4.7.2 To set the timer

When setting the timer, calculate that the robotic lawnmower mows about the amount of the number of square meters per hour and day listed in table Work capacity.

Model	Work capacity, m ² per hour and day
Automower® 310	About 56
Automower® 315	About 68

If the working area is for example 800 m² in size, Automower® 310 must operate for 14 hours a day. The times are approximate and depend for instance on grass quality, blade sharpness and battery age.



WARNING: Use the timer to avoid mowing when there are usually children, pets and anything else that could be damaged by the rotating blades on the lawn.

The factory settings for the timer allow the robotic lawnmower to operate around the clock 7 days a week. However, the robotic lawnmower will not operate during the built-in standby period.

4.7.3 Example 1

The times used in this example are applicable to Automower® 310, but the principle is the same for other models.

Timer setting, *Period 1*: 00:00 - 00:00

Active period (A): 00:00 - 18:00

The factory setting ensures that the robotic lawnmower begins cutting the lawn at 00:00. However the mower is parked in standby mode in the charging station from 18:00 and rests until it starts cutting again at 00:00.

If the timer setting is divided into 2 work periods, the standby period can be divided into a number of periods. The minimum standby period time must however be according to the Standby time table.

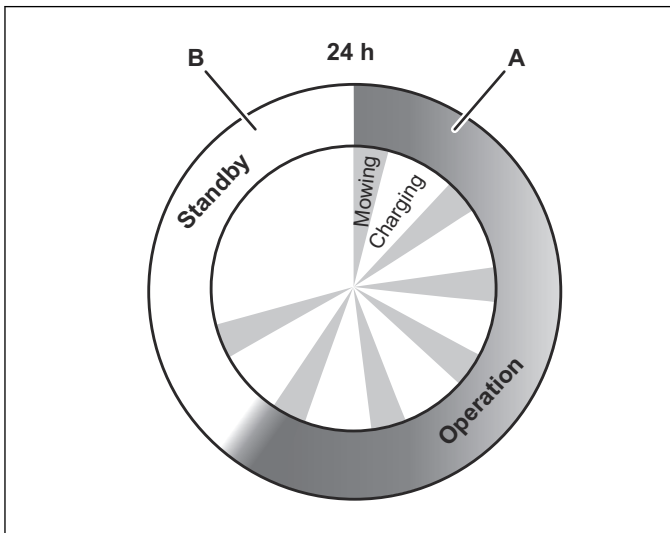

Automower® 310	
Operation, A = max. hours	18
Charging/Standby, B = min. hours	6

4.7.4 Example 2

The times used in this example are applicable to Automower® 310, but the principle is the same for the other models.

Timer setting *Period 1* (A): 00:00 - 16:00

Timer setting *Period 2* (C): 20:00 - 23:00

Active period (A): 00:00 - 16:00

Active period (C): 20:00 - 22:00

The robotic lawnmower will operate between 00:00 and 16:00. It will begin again at 20:00 but stops running at 23:00 due to standby mode until it starts again at 00:00.

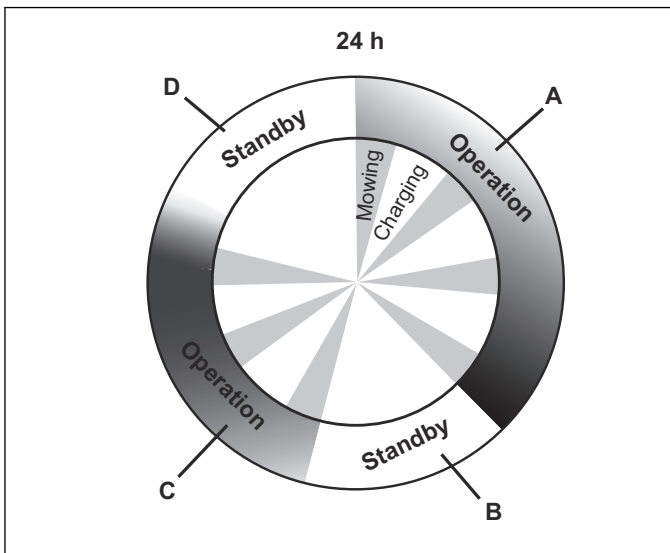

Automower® 310	
Operation, A + C = max. hours	18
Charging/Standby, B + D = min. hours	6

4.8 Charge a flat battery

When the Husqvarna robotic lawnmower is new or has been stored for a long period, the battery will be flat and needs to be charged before starting.



WARNING: Only charge the robotic lawnmower using a charging station which is intended for it. Incorrect use may result in electric shock, overheating or leakage of corrosive liquid from the battery.

In the event of leakage of electrolyte flush with water and seek medical help if it comes in contact with the eyes etc.

1. Set the main switch to position 1.
2. Place the robotic lawnmower in the charging station. Open the hatch and slide the robotic lawnmower in as far as possible to ensure proper contact between the robotic lawnmower and the charging station. See contact and charging strips in *Charging the battery on page 12*
3. The display shows a message that charging is in progress.

4.9 Adjust the cutting height

The cutting height can be varied from MIN (2 cm) to MAX (6 cm).



CAUTION: During the first weeks after a new installation, the cutting height must be set to MAX to avoid damaging the loop wire. After this, the cutting height can be lowered step by step every week until the desired cutting height has been reached.

4.9.1 To adjust the cutting height

1. Press the **STOP** button to stop the robotic lawnmower.
2. Open the hatch.

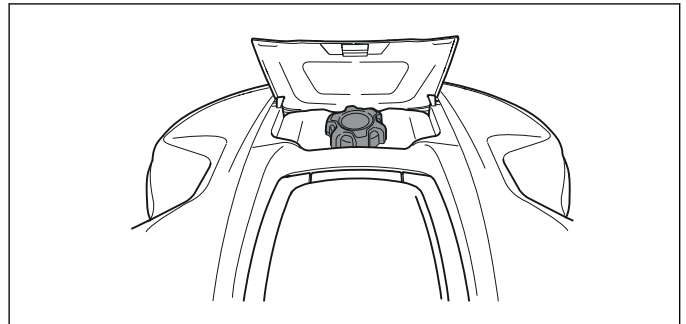

3. Turn the knob to the required position.
 - Turn clockwise to increase the cutting height.
 - Turn counter-clockwise to decrease the cutting height.
4. Close the hatch.

5 Maintenance

5.1 Introduction - maintenance

For better operating reliability and longer service life: check and clean the robotic lawnmower regularly and replace worn parts if necessary. All maintenance and servicing must be done according to Husqvarna's instructions. See *Guarantee terms on page 59*.

When the robotic lawnmower is first used, the blade disc and blades should be inspected once a week. If the amount of wear during this period has been low, the inspection interval can be increased.

It is important that the blade disc rotates easily. The edges of the blades should not be damaged. The lifetime of the blades varies immensely and depends for instance on:

- Operating time and size of the working area.
- Type of grass and seasonal growth.
- Soil, sand and use of fertilizers.
- The presence of objects such as, toys, tools, stones, roots and the like.

The normal life is 3 to 6 weeks when used under favorable conditions. See *Replace the blades on page 46* on how to replace the blades.



WARNING: Wear protective gloves.

Note: Working with blunt blades gives a poorer mowing result. The grass is not cut cleanly and more energy is needed, resulting in the robotic lawnmower not being able to maintain such a large area.

5.2 Clean the robotic lawnmower

It is important to keep the robotic lawnmower clean. A mower with large amounts of grass stuck to it will not cope as well with slopes. It is recommended to clean using a brush.

Husqvarna offers a special cleaning and maintenance kit as an accessory. Please, contact Husqvarna customer service.



CAUTION: Never use a high-pressure washer to clean the robotic lawnmower. Never use solvents for cleaning.

5.2.1 Chassis and blade disc

1. Set the **Main switch** to position 0.
2. Lift the robotic lawnmower onto its side.
3. Clean the blade disc and chassis using for example a dish brush. At the same time, check that the blade disc rotates freely in relation to the foot guard. Also, check that the blades are intact and can pivot freely. If long grass or other objects find their way in, these may impede the blade disc. Even a slight braking effect leads to a higher consumption of energy and

at worst will prevent the robotic lawnmower from being able to mow a large lawn.

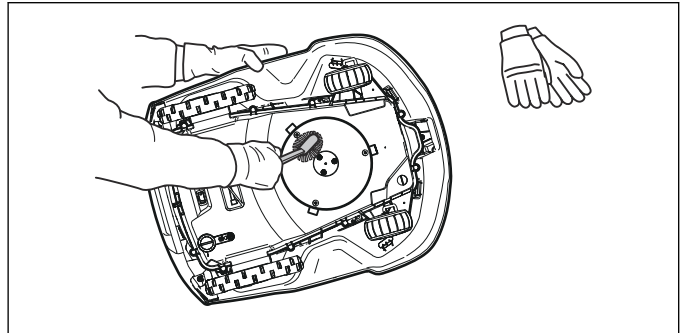

5.2.2 Chassis

Clean the underside of the chassis. Brush or wipe with a damp cloth.

5.2.3 Wheels

Clean around the front wheels and rear wheel as well as the rear wheel bracket. Grass on the wheels can impact on how the lawnmower works in slopes.

5.2.4 Body

Use a damp, soft sponge or cloth to clean the body. If the body is very dirty it may be necessary to use a soap solution or washing-up liquid.

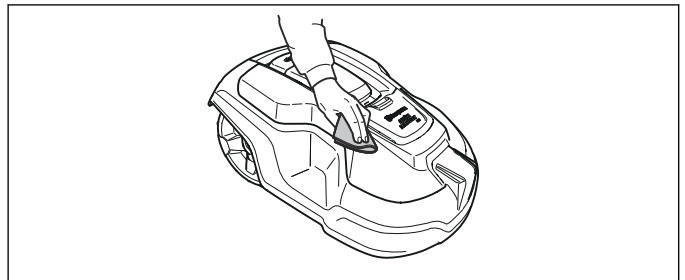

5.2.5 Charging station

Clean the charging station regularly from grass, leaves, twigs and other objects that may impede docking.

5.3 Replace the blades



WARNING: Always use blades and screws of the right type. Husqvarna can only guarantee safety when using original blades. Only replacing the blades and reusing the screw can result in a screw wearing during mowing and shearing. The blades can then be propelled from under the body and cause serious injury.

Replace worn or damaged parts for safety reasons. Even if the blades are intact, they should be replaced on a regular basis for the best mowing result and low energy usage.

All 3 blades and screws must be replaced at the same time to obtain a balanced cutting system.

Use Husqvarna original blades embossed with the crowned H-mark logotype, see *Guarantee terms on page 59*.

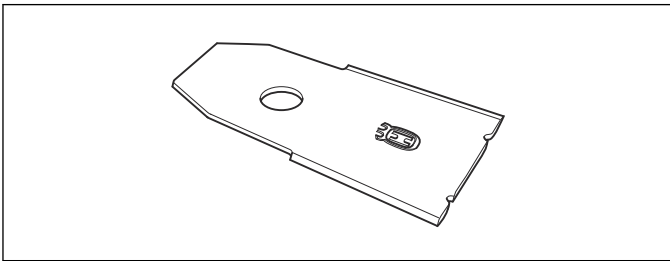

5.3.1 To replace the blades

1. Set the **Main switch** to position 0.

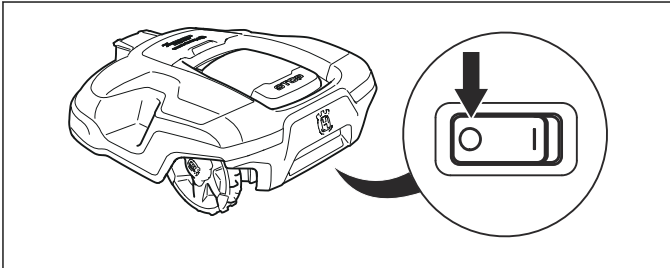

2. Turn the robotic lawnmower upside down. Place the robotic lawnmower on a soft and clean surface to avoid scratching the body and the hatch.
3. Rotate the skid plate so that its holes align with the screws for the blade.
4. Remove the 3 screws. Use a straight slot or cross-tip screwdriver.

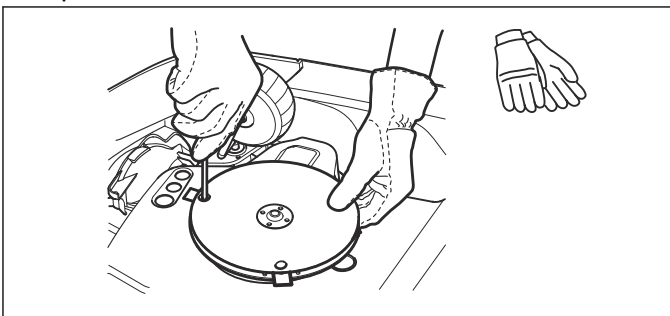

5. Remove each blade and screw.
6. Fasten new blades and screws.
7. Check that the blades can pivot freely.

5.4 Battery

The battery is maintenance-free, but has a limited life span of 2 to 4 years.



WARNING: Only charge the robotic lawnmower using a charging station which is intended for it. Incorrect use may result in electric shock, overheating or leakage of corrosive liquid from the battery. In the event of leakage of electrolyte flush with water and seek medical help if it comes in contact with the eyes etc.



WARNING: Use only original batteries recommended by the manufacturer. Product safety cannot be guaranteed with other batteries. Do not use non-rechargeable batteries.



CAUTION: The battery must be charged fully before winter storage. If the battery is not fully charged it can be damaged and in certain cases be rendered useless.

Below indicates that the battery is getting old and eventually needs replacing:

- The operating time for the robotic lawnmower is shorter than normal between charges. This leads to more charging cycles than normal, which increases the risk of tracks forming near the charging station.
- The robotic lawnmower is found standing out on the lawn with *Empty battery* message. This indicates that the robotic lawnmower does not have battery capacity enough to find the charging station.

The battery is fine as long as the robotic lawnmower maintains a well-cut lawn.

Note: Battery life is dependent on the length of the season and how many hours a day the robotic lawnmower is operating. A long season or many hours of use a day means that the battery must be replaced more regularly.

Contact your local Husqvarna representative to replace the battery.

5.5 Winter service

Take your robotic lawnmower to your local Husqvarna representative for service prior to winter storage. Regular winter service will maintain the robotic lawnmower in good condition and create the best conditions for a new season without any disruptions.

Service usually includes the following:

- Thorough cleaning of the body, the chassis, the blade disc and all other moving parts.
- Testing of the mower's function and components.
- Checking and, if required, replacing wear items such as blades and bearings.
- Testing the mower's battery capacity as well as a recommendation to replace battery if necessary.
- If new software is available, the local Husqvarna representative updates the robotic lawnmower.

6 Troubleshooting

6.1 Introduction - troubleshooting

In this chapter, a number of messages are listed which may be shown in the display if there is a malfunction. There is a proposal as to the cause and steps to take for each message. This chapter also presents some symptoms that can guide you if the robotic lawnmower does not work as expected. More suggestions for steps to take in the event of malfunction or symptoms can be found on www.husqvarna.com.

6.2 Fault messages

Below a number of fault messages are listed which may be shown in the display of the robotic lawnmower. Contact your local Husqvarna representative if the same message appears often.

Message	Cause	Action
<i>Wheel motor blocked, left</i>	Grass or other object has wrapped around the drive wheel.	Check the drive wheel and remove the grass or other object.
<i>Wheel motor blocked, right</i>	Grass or other object has wrapped around the drive wheel.	Check the drive wheel and remove the grass or other object.
<i>Cutting system blocked</i>	Grass or other object has wrapped around the blade disc.	Check the drive wheel and remove the grass or other object.
	The blade disc lies in a pool of water.	Move the robotic lawnmower and prevent the collection of water in the working area.
<i>No loop signal</i>	The power supply is not connected.	Check the wall socket connection and whether an earth-fault breaker has tripped or not. Check that the low voltage cable is connected to the charging station.
	The low voltage cable is damaged or not connected.	Check that the low voltage cable is not damaged. Check that it is also properly connected to the charging station and to the power supply.
	The boundary wire is not connected to the charging station.	Check that the boundary wire connectors are fitted properly to the charging station. Replace connectors if damaged. See <i>Connecting the boundary wire on page 17</i> .
	Boundary wire broken.	Find out where the break is. Replace the damaged section of the loop with a new loop wire and splice using an original coupler. See <i>Find breaks in the loop wire on page 53</i> .
	<i>ECO mode</i> is activated and the robotic lawnmower has attempted to start outside the charging station.	Place the robotic lawnmower in the charging station, press the START button and close the hatch. See <i>Settings on page 32</i> .
	The boundary wire is crossed on its way to and from an island.	Check that the boundary wire is laid according to instructions, e.g. in the right direction around the island. See <i>Installation on page 27</i> .
	The connection between the robotic lawnmower and the charging station has been broken.	Place the robotic lawnmower in the charging station and generate a new loop signal, see <i>Security on page 25</i> .
	Disturbances from metal objects (fences, reinforcement steel) or buried cables close by.	Try moving the boundary wire.
<i>Trapped</i>	The robotic lawnmower has got caught in something.	Free the robotic lawnmower and rectify the reason for it becoming trapped.
	The robotic lawnmower is stuck behind a number of obstacles.	Check if there are any obstacles which make it hard for the robotic lawnmower to move on from this location.

Message	Cause	Action
<i>Outside working area</i>	The boundary wire connections to the charging station are crossed.	Check that the boundary wire is connected correctly.
	The boundary wire is too close to the edge of the working area.	Check that the boundary wire has been laid according to the instructions. See <i>Installation on page 27</i> .
	The working area slopes too much by the boundary loop.	
	The boundary wire is laid in the wrong direction around an island.	
	Disturbances from metal objects (fences, reinforcement steel) or buried cables close by.	Try moving the boundary wire.
	The robotic lawnmower finds it hard to distinguish the signal from another robotic lawnmower installation close by.	Place the robotic lawnmower in the charging station and generate a new loop signal, see <i>Security on page 25</i> .
<i>Empty battery</i>	The robotic lawnmower cannot find the charging station.	Check that the charging station and the guide wire are installed in accordance with the instructions. See <i>Installation of the guide wire on page 17</i> .
	The guide wire is broken or not connected.	Find out where the break is and rectify it.
	The battery is spent.	Replace the battery. See <i>Battery on page 47</i> .
	The charging station's antenna is defective.	Check if the indicator lamp in the charging station flashes red. See <i>Indicator lamp in the charging station on page 52</i> .
<i>Wrong PIN code</i>	Wrong PIN code has been entered. Five attempts are permitted, and the keypad is then blocked for five minutes.	Enter the correct PIN code. Contact your local Husqvarna representative if you forget the PIN code.
<i>No drive</i>	The robotic lawnmower has got caught in something.	Free the robotic lawnmower and rectify the reason for the lack of drive. If it is due to wet grass, wait until the lawn has dried before using the robotic lawnmower.
	The working area includes a steep slope.	Maximum guaranteed slope is 40%. Steeper slopes should be isolated. See <i>Slopes on page 15</i> .
	The guide wire is not laid at an angle on a slope.	If the guide wire is laid on a slope, it must be laid at an angle across the slope. See <i>Installation of the guide wire on page 17</i> .
<i>Wheel motor overloaded, right</i>	The robotic lawnmower has got caught in something.	Free the robotic lawnmower and rectify the reason for the lack of drive. If it is due to wet grass, wait until the lawn has dried before using the robotic lawnmower.
<i>Wheel motor overloaded, left</i>		
<i>Charging station blocked</i>	The contact between the charging strips and contact strips may be poor and the robotic lawnmower has made a number of attempts to charge.	Put the robotic lawnmower in the charging station and check that the charging strips and contact strips make good contact.
	An object is obstructing the robotic lawnmower.	Remove the object.
	The charging station is tilted or bent.	Confirm that the charging station is placed on a fully flat and horizontal ground. The charging station must not be tilted or bent.

Message	Cause	Action
<i>Stuck in charging station</i>	There is an object in the way of the robotic lawnmower preventing it from leaving the charging station.	Remove the object.
<i>Upside down</i>	The robotic lawnmower is leaning too much or has turned over.	Turn the robotic lawnmower the right way up.
<i>Needs manual charging</i>	The robotic lawnmower is set to the <i>Secondary area</i> operating mode.	Place the robotic lawnmower in the charging station. This behaviour is normal and no action is required.
<i>Next start hh:mm</i>	The timer setting prevents the robotic lawnmower from operating.	Change the timer settings. See <i>Timer on page 24</i> .
	The rest period is in progress. The robotic lawnmower has an inbuilt standby period according to the Standby time table.	This behaviour is normal and no action is required. See <i>Standby on page 44</i> .
	The clock on the robotic lawnmower is not correct.	Set the time. See <i>Time & Date on page 34</i> .
<i>The day's mowing is complete</i>	The rest period is in progress. The robotic lawnmower has an inbuilt standby period according to the Standby time table.	This behaviour is normal and no action is required. See <i>Standby on page 44</i> .
<i>Lifted</i>	The lift sensor has been activated as the mower has become trapped.	Free the mower
<i>Collision sensor problem, front/rear</i>	Mower body can not move freely around its chassis.	Check that the mower body can move freely around its chassis. If the problem remains, the message requires action by authorized service technician.
<i>Wheel drive problem, right/left</i>	Grass or other object is wrapped around the drive wheel.	Clean the wheels and around the wheels.
<i>Alarm! Mower switched off</i>	The alarm was activated because the mower was switched OFF.	Adjust the mower security level in the <i>Security</i> menu, see <i>Security on page 25</i> .
<i>Alarm! Mower stopped</i>	The alarm was activated because the mower was stopped.	
<i>Alarm! Mower lifted</i>	The alarm was activated because the mower was lifted.	
<i>Alarm! Mower tilted</i>	The alarm was activated because the mower was tilted.	
<i>Electronic problem</i>	Temporary electronic or software related issue in the mower.	Restart the mower.
<i>Loop sensor problem, front/rear</i>		If the problem remains, the message requires action by authorized service technician.
<i>Charging system problem</i>		
<i>Tilt sensor problem</i>		
<i>Temporary problem</i>		
<i>Temporary battery problem</i>	Temporary battery or software related issue in the mower.	Restart the mower.
<i>Battery problem</i>		Disconnect and reconnect the battery. If the problem remains, the message requires action by authorized service technician.
<i>Charging current too high</i>	Wrong or faulty power supply unit.	Restart the mower. If the problem remains, the message requires action by authorized service technician.

Message	Cause	Action
<i>Connectivity problem</i>	Potential problem on the connectivity circuit board in the mower.	Restart the mower. If the problem remains, the message requires action by authorized service technician.
<i>Connectivity settings restored</i>	The connectivity settings was restored due to a fault.	Please check and change the settings if needed.
<i>Poor signal quality</i>	The connectivity circuit board in the mower is assembled upside down, or the mower itself is tilted or upside down.	Verify the mower is not upside down or tilted. If not, the message requires action by authorized service technician.

6.3 Information messages

Below a number of information messages are listed which may be shown in the display of the robotic lawnmower. Contact your local Husqvarna representative if the same message appears often.

Message	Cause	Action
<i>Low battery</i>	The robotic lawnmower cannot find the charging station.	Check that the charging station and the guide wire are installed in accordance with the instructions. See <i>Installation on page 27</i> .
	The guide wire is broken or not connected.	Find out where the break is and rectify it.
	The battery is spent.	Replace the battery. See <i>Battery on page 47</i> .
	The charging station's antenna is defective.	Check if the indicator lamp in the charging station flashes red. See <i>Indicator lamp in the charging station on page 52</i> .
<i>Settings restored</i>	Confirmation that a <i>Reset all user settings</i> has been carried out.	This is normal. No action required.
<i>Guide not found</i>	The guide wire is not connected to the charging station.	Check that the guide wire's connector is tightly connected to the charging station. See <i>Laying and connecting the guide wire on page 18</i> .
	Break in the guide wire.	Find out where the break is. Replace the damaged section of the guide wire with a new loop wire and splice using an original coupler.
	The guide wire is not connected to the boundary loop.	Check that the guide wire is connected correctly to the boundary loop. See <i>Laying and connecting the guide wire on page 18</i> .
<i>Guide calibration failed</i>	The robotic lawnmower has failed to calibrate the guide wire.	Check that the guide wires are installed according to the instructions, See <i>Installation of the guide wire on page 17</i> .
<i>Guide calibration accomplished</i>	The robotic lawnmower has succeeded to calibrate the guide wire.	No action required.
<i>Difficult finding home</i>	The robotic lawnmower has been following the boundary wire several laps without finding the charging station.	The installation has not been done correctly. See <i>Plan where to lay the boundary wire on page 13</i> .
		Wrong corridor width setting on boundary wire. See <i>Find charging station on page 29</i> .
		The mower was started on a Secondary area with the Main area setting.

6.4 Indicator lamp in the charging station

For a fully functional installation, the indicator lamp in the charging station must emit a solid or flashing green light. If something else appears, follow the troubleshooting guide below.

There is more help on www.husqvarna.com. If you still need help, please contact your local Husqvarna representative.

Light	Cause	Action
<i>Solid green light</i>	Good signals	No action required
<i>Green flashing light</i>	The signals are good and <i>ECO mode</i> is activated.	No action required. For more information on <i>ECO mode</i> , see <i>Settings on page 32</i> .
<i>Blue flashing light</i>	The boundary loop is not connected to the charging station.	Check that the boundary wire connectors are fitted properly to the charging station. See <i>Connecting the boundary wire on page 17</i> .
	Break in the boundary loop.	Find out where the break is. Replace the damaged section of the loop with a new loop wire and splice using an original coupler.
<i>Red flashing light</i>	Interruption in the charging station's antenna.	Contact your local Husqvarna representative.
<i>Solid red light</i>	Fault in the circuit board or incorrect power supply in the charging station. The fault should be rectified by an authorized service technician.	Contact your local Husqvarna representative.

6.5 Symptoms

If your robotic lawnmower does not work as expected, follow the symptoms guide below.

There is a FAQ (Frequently Asked Questions) on www.husqvarna.com which provides more detailed answers to a number of standard questions. Contact your local Husqvarna representative if you still cannot find the reason for the fault.

Symptoms	Cause	Action
The robotic lawnmower has difficulty docking.	The boundary wire is not laid in a long straight line that is far enough out from the charging station.	Check that the charging station has been installed according to the instructions in <i>Installing and connecting the charging station on page 12</i>
	The guide wire is not inserted in the slot under the charging station.	It is absolutely critical for operation that the guide wire is perfectly straight and is in the correct position under the charging station. Therefore make sure that the guide wire is always in its slot in the charging station. See <i>Laying and connecting the guide wire on page 18</i> .
	The charging station is on a slope.	Place the charging station on a surface that is entirely level. See <i>Best charging station location on page 10</i> .
The robotic lawnmower runs at the wrong time	The robotic lawnmower clock needs to be set.	Set the clock. See <i>Time & Date on page 34</i> .
	The start and stop times for mowing are incorrect.	Reset the start time and stop time settings for mowing. See <i>Timer on page 24</i> .
The robotic lawnmower vibrates.	Damaged blades lead to imbalance in the cutting system.	Inspect the blades and screws and replace them if necessary. See <i>To replace the blades on page 47</i> .
	Too many blades in the same position lead to imbalance in the cutting system.	Check that only one blade is fitted at each screw.
	Different versions (thickness) of Husqvarna blades are used.	Check if the blades are of different versions.

Symptoms	Cause	Action
The robotic lawnmower runs, but the blade disc does not rotate.	The robotic lawnmower searches for the charging station.	No action. The blade disc does not rotate when the robotic lawnmower is searching for the charging station.
The robotic lawnmower mows for shorter periods than usual between charges.	Grass or other foreign object blocks the blade disc.	Remove and clean the blade disc. See <i>Clean the robotic lawnmower on page 46</i> .
	The battery is spent.	Replace the battery. See <i>Battery on page 47</i> .
Both the mowing and charging times are shorter than usual.	The battery is spent.	Replace the battery. See <i>Battery on page 47</i> .
The robotic lawnmower is parked for hours in the charging station.	The robotic lawnmower has an inbuilt standby period according to the Standby time table. See <i>Standby on page 44</i> .	No action.
	The hatch has been closed without the START button first being pressed.	Open the hatch, press the START button and then close the hatch.
The robotic lawnmower often moves in circles or spirals.	Spiral cutting is a natural part of the robotic lawnmower's movement.	Adjust how often spiral cutting shall be performed. The function can be disabled if necessary. See <i>Spiral cutting on page 33</i> .
Uneven mowing results.	The robotic lawnmower works too few hours per day.	Increase the mowing time. See <i>Timer on page 24</i> .
	The <i>How often?</i> setting is incorrect in relation to the layout of the working area.	Check that the correct <i>How often?</i> value is selected.
	The shape of the working area requires the use of <i>Area 1-3</i> for the robotic lawnmower to find its way to all remote areas.	Use <i>Area 1-3</i> to steer the robotic lawnmower to a remote area. See <i>Lawn coverage (Automower® 310 and Automower® 315) on page 27</i> .
	Working area too large.	Try limiting the working area or extending the working time. See <i>Timer on page 24</i> .
	Dull blades.	Replace all the blades. See <i>To replace the blades on page 47</i> .
	Long grass in relation to the set cutting height.	Increase the cutting height and then successively lower.
	Accumulation of grass by the blade disc or around the motor shaft.	Check that the blade disc rotates freely and easily. If not, screw off the blade disc and remove grass and foreign objects. See <i>Clean the robotic lawnmower on page 46</i> .

6.6 Find breaks in the loop wire

Breaks in the loop wire are usually the result of unintentional physical damage to the wire such as when gardening with a shovel. In countries with ground frost, also sharp stones that move in the ground can damage the wire. Breaks can also occur due to the wire being stretched excessively during installation.

Mowing the grass too low right after the installation can damage wire insulation. Damage to the insulation may not cause disruptions until several weeks or months later. To avoid this, always select the maximum cutting height the first weeks after installation and then lower the height one step at a time every second week until the desired cutting height has been reached.

A defective splicing of the loop wire can also lead to disruptions several weeks after the splice was done. A faulty splice can, for example, be the result of the

original coupler not being pressed together hard enough with a pair of pliers, or that a coupler of lower quality than the original coupler has been used. Please first check all known splices before further troubleshooting is done.

A wire break can be located by gradually halving the distance of the loop where the break may have occurred until there is only a very short section of the wire left.

The following method does not work if *ECO mode* is activated. Make sure first that *ECO mode* is turned off. See *ECO mode on page 33*.

1. Check that the indicator lamp in the charging station flashes blue, which indicates a break in the boundary loop. See *Indicator lamp in the charging station on page 52*.

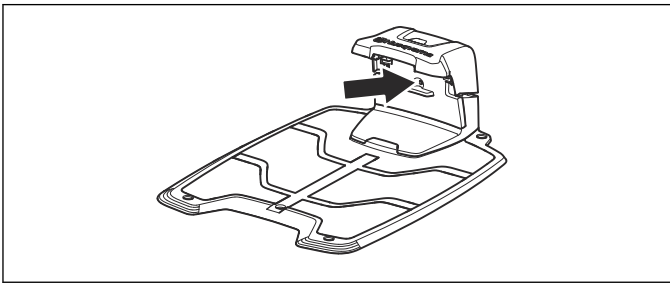

2. Check that the boundary wire connections to the charging station are properly connected and not damaged. Check that the indicator lamp in the charging station is still flashing blue.

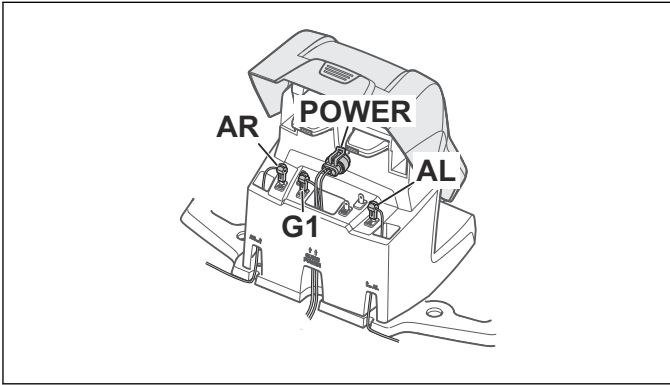

3. Switch the connections between the guide wire and the boundary wire in the charging station.

Start by switching connection AL and G1.

If the indicator lamp is lit with a solid green light, then the break is somewhere on the boundary wire between AL and the point where the guide wire is connected to the boundary wire (thick black line in the illustration).

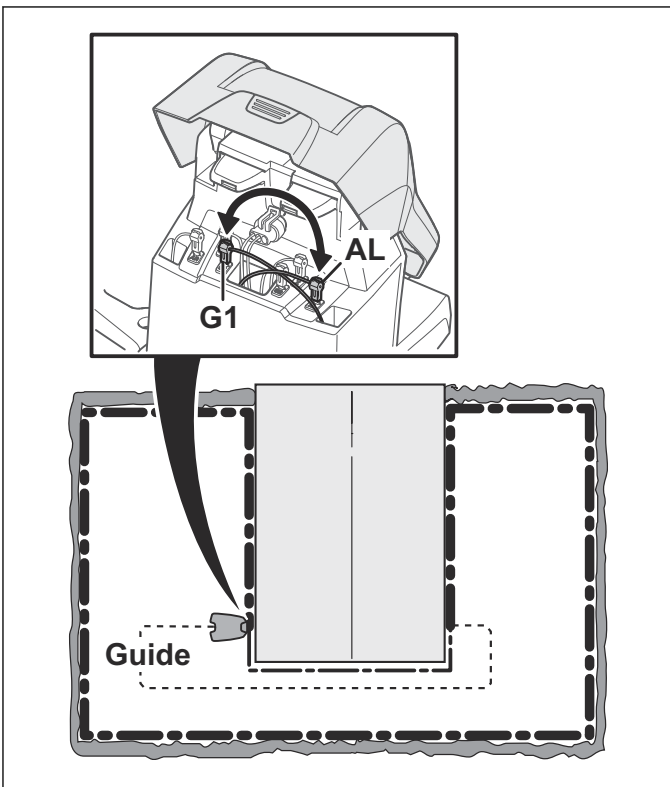

To rectify the fault you will need boundary wire, connector(s) and coupler(s):

a) If the suspected boundary wire is short then it is easiest to exchange all of the boundary wire between AL and the point where the guide wire is connected to the boundary wire (thick black line).

b) If the suspected boundary wire is long (thick black line) then do as follows: Put AL and G1 back to their original positions. Then disconnect AR. Connect a new loop wire to AR. Connect the other end of this new loop wire at the middle of the suspected wire section.

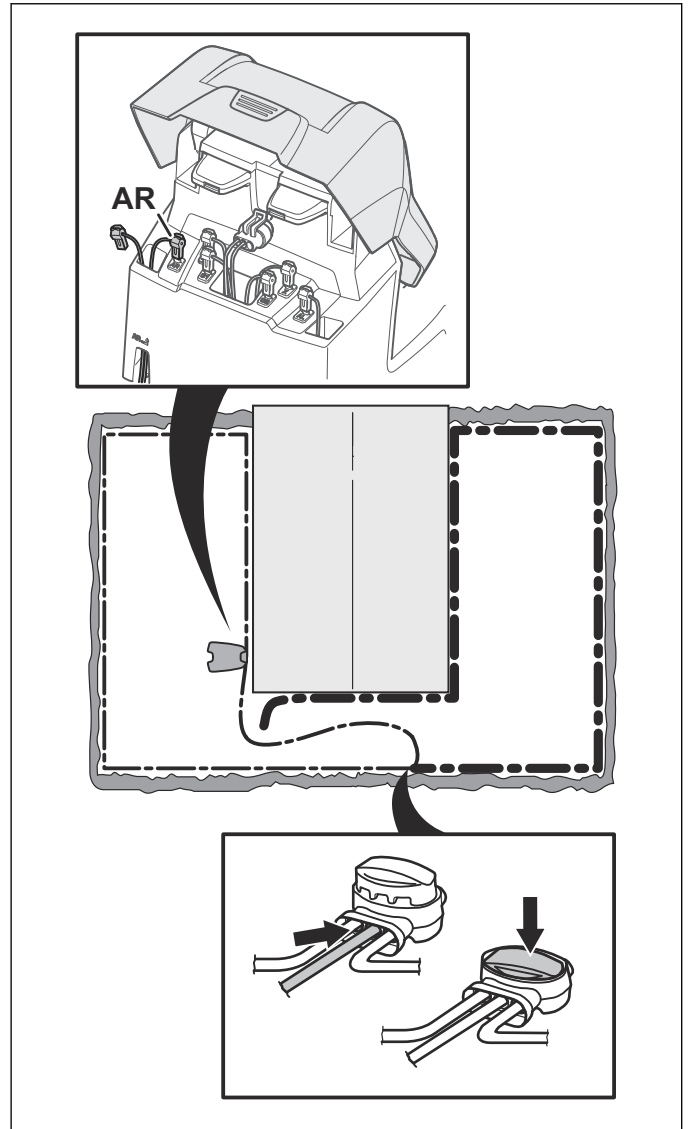

If the indicator lamp now is green, then the break is somewhere in the wire between the disconnected end to the point where the new wire is connected (thick black line below). In that case, move the connection for the new wire closer to the disconnected end (roughly at the middle of the suspected wire section) and check again if the indicator lamp is green.

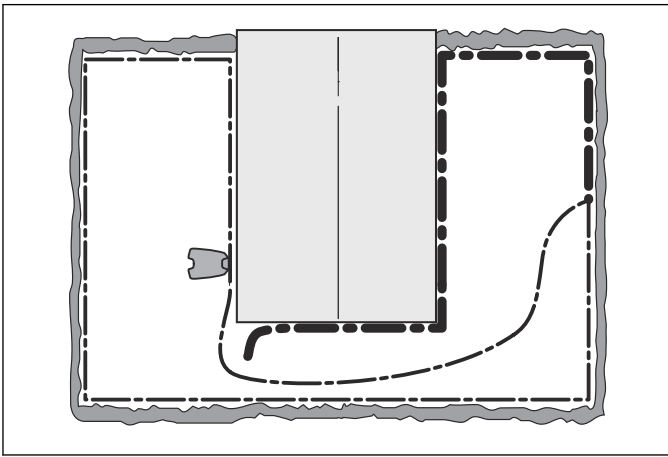

Continue until only a very short section of the wire remains which is the difference between a solid green light and a flashing blue light. Then follow instruction in step 5 below.

4. If indicator lamp still flashes blue in step 3 above: Put AL and G1 back in their original positions. Then switch AR and G1. If indicator lamp now is lit with a solid green light then disconnect AL and connect a new boundary wire to AL. Connect the other end of this new wire at the middle of the suspected wire section. Follow the same approach as in 3a) and 3b) above.
5. When the break is found, the damaged section must be replaced with a new wire. Always use original couplers.

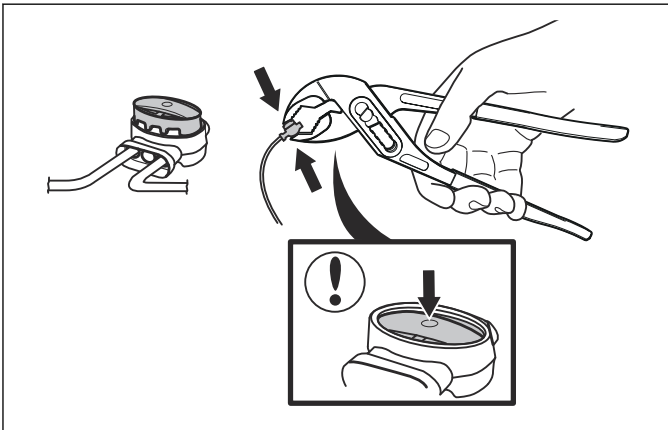

7 Transportation, storage and disposal

7.1 Transportation

The supplied Li-ion batteries obey the Dangerous Goods Legislation requirements.

- Obey all applicable national regulations.
- Obey the special requirement on package and labels for commercial transportations, including by third parties and forwarding agents.

7.2 Storage

- Fully charge the product. Refer to *Charging the battery on page 12*.
- Disconnect the product with the **main switch**. Refer to *Main switch on page 43*.
- Clean the product. Refer to *Clean the robotic lawnmower on page 46*.
- Keep the product in a dry, frost free space.
- Keep the product with all wheels on level ground during storage, or use a Husqvarna wall hanger.
- If you keep the charging station indoors, disconnect and remove the power supply and all the connectors from the charging station. Put the end of each connector wire in a container with grease.
- If you keep the charging station outdoors, do not disconnect the power supply and the connectors.

7.3 Disposal

- Obey the local recycling requirements and applicable regulations.
- For questions about how to remove the battery, refer to *Removal of battery for recycling on page 56*.

7.3.1 Removal of battery for recycling

Follow these steps for removal of the battery from the robotic lawnmower.

1. Set the **Main switch** in position 0.
2. Clean the area around the grommet for the charging cable found at the very front under the mower.
3. Pull out the rubber grommet on the charging cable and carefully loosen the connector.

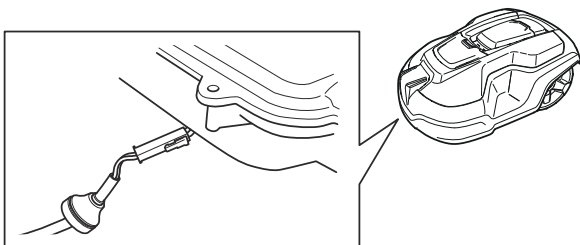

4. The body is fitted to the chassis using 4 quick-mounted, snap-on brackets. Loosen the body from the chassis by lifting the body one corner at a time

while holding the chassis in place.

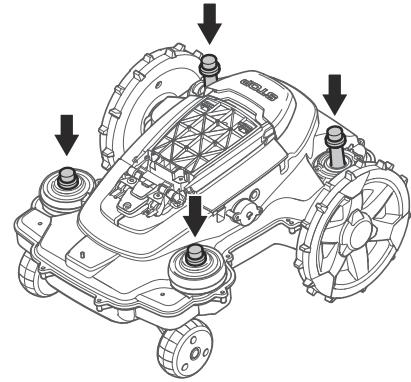

5. Loosen all 14 screws (Torx 20).

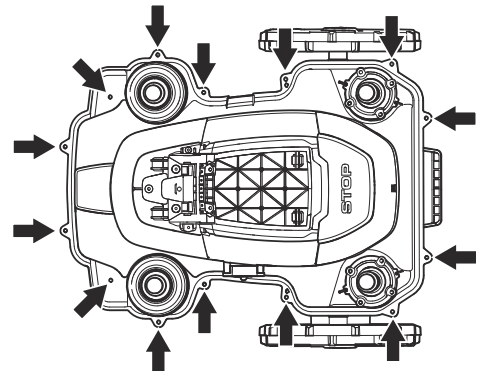

6. Remove the guarantee seal at the point of separation between the chassis halves on the right-hand side.
7. Carefully lift the rear edge of the upper section of the chassis.
8. Disconnect the MMI cable from the main circuit board and remove the upper section of the chassis.
9. Loosen the 3 screws (Torx 20) holding the battery cover in place.

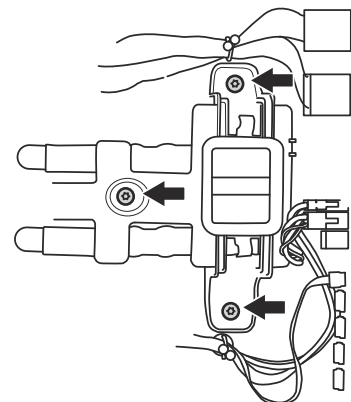

10. Disconnect the battery connection from the main circuit board. Open the battery cover and remove the battery.

8 Technical data

8.1 Technical data

Dimensions	Automower® 310	Automower® 315	Automower® 315X
Length, cm	63	63	63
Width, cm	51	51	51
Height, cm	25	25	25
Weight, kg	8.5	8.5	10.1

Electrical system	Automower® 310	Automower® 315	Automower® 315X
Battery, Lithium-Ion 18 V/2.1 Ah Art.No	584 85 28-01, 584 85 28-02	584 85 28-01, 584 85 28-02	584 85 28-01, 584 85 28-02
Power supply, V/28 V DC	100-240	100-240	100-240
Low voltage cable length, m	10	10	10
Mean energy consumption at maximum use	8 kWh/month in a 1000 m ² working area	10 kWh/month in a 1500 m ² working area	10 kWh/month in a 1600 m ² working area
Charge current, A DC	1.3	1.3	1.3
Average mowing time, min	70	70	70
Average charging time, min	60	60	60

Boundary wire antenna	Automower® 310	Automower® 315	Automower® 315X
Operating Frequency Band, Hz	300-28900	300-28900	300-80000
Maximum Radio-frequency power, mW @60m ⁵	<25	<25	<25

Noise emissions measured in the environment as sound power ⁶	Automower® 310	Automower® 315	Automower® 315X
Measured sound power noise level, dB (A)	58	58	58
Noise emissions uncertainties K _{WA} , dB (A)	2	2	2
Guaranteed sound power noise level, dB (A)	60	60	60
Sound pressure noise level at the operator's ear, dB (A) ⁷	47	47	47

The noise emission declarations conforms to EN 50636-2-107:2015

⁵ Maximum active output power to antennas in the frequency band in which the radio equipment operates.

⁶ **Noise emissions in the environment measured as sound power (L_{WA}) in conformity with EC directive 2000/14/EC. The guaranteed sound power level includes variation in production as well as variation from the test code with 1-3 dB(A).**

⁷ Sound pressure noise uncertainties K_{pA}, 2-4 dB (A)

Mowing	Automower® 310	Automower® 315	Automower® 315X
Cutting system	3 pivoted cutting blades		
Blade motor speed, rpm	2300	2300	2300
Power consumption during cutting, W +/- 20 %	25	25	25
Cutting height, cm	2-6	2-6	2-6
Cutting width, cm	22	22	22
Narrowest possible passage, cm	60	60	60
Maximum angle for cutting area, %	40	40	40
Maximum angle for boundary wire, %	15	15	15
Maximum length boundary wire, m	800	800	800
Maximum length guide wire, m	400	400	400
Working capacity, m ² +/- 20%	1000	1500	1600

IP-classification	Automower® 310	Automower® 315	Automower® 315X
Robotic lawnmower	IPX4	IPX4	IPX4
Charging station	IPX1	IPX1	IPX1
Power supply	IPX4	IPX4	IPX4

Frequency Band Support	
Bluetooth® Frequency range	2400.0-2483.5 MHz
Automower® Connect 3G	Band 19 (800 MHz)
	Band 5 (850 MHz)
	Band 8 (900 MHz)
	Band 2 (1900 MHz)
	Band 1 (2100 MHz)
Automower® Connect 2G	GSM 850 MHz
	E-GSM 900 MHz
	DCS 1800 MHz
	PCS 1900 MHz

Power Class		
Bluetooth® Output power	8 dBm	
Automower® Connect 3G	Power Class 3	24 dBm
Automower® Connect 2G	Power Class 4 (for GSM/E-GSM)	33 dBm
	Power Class 1 (for DCS/PCS)	30 dBm

Husqvarna AB does not guarantee full compatibility between the robotic lawnmower and other types of wireless systems such as remote controls, radio transmitters, hearing loops, underground electric animal fencing or similar.

9 Warranty

9.1 Guarantee terms

Husqvarna guarantees this product's functionality for a period of two years (from date of purchase). The guarantee covers serious faults relating to materials or manufacturing faults. Within the guarantee period, we will replace the product or repair it at no charge if the following terms are met:

- The robotic lawnmower and the charging station may only be used in compliance with the instructions in this Operator's Manual. This manufacturer's guarantee does not have an effect on the user's existing warranty claims against the dealer/seller.
- End-users or non-authorized third parties must not attempt to repair the product.

Examples of faults which are not included in the guarantee:

- Damage caused by water seepage from using a high-pressure washer, or from being submerged under water, for example when heavy rain forms pools of water.
- Damage caused by lightning.
- Damage caused by improper battery storage or battery handling.
- Damage caused by using a battery that is not a Husqvarna original battery.
- Damage caused by not using Husqvarna original spare parts and accessories, such as blades and installation material.
- Damage to the loop wire.
- Damage caused by non-authorized changing or tampering with the product or its power supply.

The blades and wheels are seen as disposable and are not covered by the guarantee.

If an error occurs with your Husqvarna robotic lawnmower, please contact Husqvarna customer service for further instructions. Please have the receipt and the robotic lawnmower's serial number at hand when contacting Husqvarna customer service.

10 EC Declaration of Conformity

10.1 EC Declaration of Conformity

Husqvarna AB, SE-561 82 Huskvarna, Sweden, tel: +46-36-146500, declares that the Robotic lawnmowers **Husqvarna Automower® 310** and **Husqvarna Automower® 315** with serial numbers dating 2017 week 45 and onwards (the year and week is clearly stated on the rating plate, followed by the serial number), comply with the requirements of the COUNCIL'S DIRECTIVE:

- Directive "relating to machinery" **2006/42/EC**.
 - Particular requirements for robotic battery powered electrical lawnmowers **EN 50636-2-107: 2015**
 - Electromagnetic fields **EN 62233: 2008**.
- Directive on "restriction of use of certain hazardous substances" **2011/65/EU**.
- Directive "relating to noise emissions from outdoor equipment" **2000/14/EC**. See also *Technical data on page 57* for information regarding noise emissions and the cutting width.

The notified body 0404, SMP Svensk Maskinprovning AB, Box 7035, SE-750 07 Uppsala, Sweden, has issued a report regarding the assessment of conformity according to annex VI to the Council's Directive of May 8, 2000 "relating to noise emissions into the environment" 2000/14/EC. The certificate is numbered: 01/901/225 for Husqvarna Automower® 310 and Husqvarna Automower® 315

- Directive "relating to radio equipment" **2014/53/EU**. The following standards have been applied:
 - Draft **ETSI EN 303 447 V1.1.1_0.0.7 (2016-07)**
- Electromagnetic compatibility:
- **ETSI EN 301 489-1** (draft version 2.1.0)

For **Husqvarna Automower® 310** and **Husqvarna Automower® 315** equipped with the **Automower® Connect** module also:

- **EN 301 489-1 v1.9.2**.
- **EN 301 489-7 v1.3.1**
- **EN 301 511 V9.0.2** (Radio Spectrum Efficiency)



Huskvarna 2017-11-01

Lars Roos

Global R&D Director, Electric category

(Authorized representative for Husqvarna AB and responsible for technical documentation.)



Husqvarna[®]

AUTOMOWER[®] is a trademark owned by Husqvarna AB.
Copyright[©] 2018 HUSQVARNA. All rights reserved.

www.husqvarna.com

Original instructions

1140542-26



2018-06-29