

**DIXON®**

**ZTR®**

**560**

**OPERATORS MANUAL**

---

## **IMPORTANT - READ CAREFULLY**

The Dixon ZTR Mower is both easy and fun to operate. However, any power mower must be operated properly to be safe. It is not a toy or a recreational vehicle. Before you start to use the mower, read the operator's manual carefully, and become completely familiar with the controls.

The information in this operator's manual applies to all Dixon ZTR Model 560 Mowers. Your Dixon dealer will gladly provide a check-out ride, and answer any questions.

See your dealer for warranty service, parts and repairs.



DIXON INDUSTRIES, INC  
A BLOUNT COMPANY  
AIRPORT INDUSTRIAL PARK  
PO BOX 1569  
COFFEYVILLE KS 67337 0945  
316 251 2000  
FAX 316 251 4117

**BLOUNT**

---

# INDEX

1. SAFETY .....	Pages	1- 3
2. WARRANTY POLICY.....	Page	4
3. SPECIFICATIONS.....	Page	5
4. SET UP AND SERVICE.....	Pages	6-12
5. OPERATION INSTRUCTIONS.....	Pages	13-14
6. CARE AND MAINTENANCE .....	Pages	15-22
7. TROUBLESHOOTING .....	Pages	23-25
8. PARTS ILLUSTRATIONS.....	Pages	26-32
9. PARTS LIST.....	Pages	33-36

---

# SAFETY

## *RIDING LAWNMOWERS, IF IMPROPERLY OPERATED, CAN CAUSE SERIOUS INJURY*

The following examples are the most common causes of injury to the operator or bystander...

1. **BLADE CONTACT:** The operator or bystander inserts a hand or foot into the discharge chute or under the mower deck and into the path of the cutting blade. Never run the mower blades when there are people nearby. Always turn the engine off when cleaning or working around the mower deck.
2. **RUN-OVER:** This situation occurs when a bystander is run-over or backed over by the mower. The most frequently cited examples are with small children who wander into, or are allowed to play in an area where the mower is being operated. Never run the mower blades when there are people nearby, especially children. Young children should be indoors and watched by an adult. Always look behind you before backing up.
3. **TIP-OVER:** This occurs when the mower tips over, usually sideways or to the rear. This situation is due to operation of the mower on steep inclines or near a drop-off. Mow across the slope to slightly uphill. Mow slopes when the grass is dry and watch for bumps, holes and other obstacles. Test the slope with the blades off. A good rule of thumb is "Don't mow on a slope you can't back up". Stay clear of drop-offs, especially if they are on the down side of a slope.
4. **THROWN OBJECTS:** The fast spinning mower deck blade can strike stones or other objects which can be hurled into the path of a bystander. To prevent this from happening, never remove the safety discharge chute from the mower deck, or operate the mower when other people are around.
5. **FIRES:** Most accidents of this type occur during re-fueling of the mower or placing the mower in a storage situation. The exhaust system and related engine components operate at very high temperatures which can ignite any fuel spilled on or near them. Always allow the mower to cool before re-fueling or placing in storage.
6. **OPERATION BY CHILDREN:** This mower is not a toy or a recreational vehicle. Never allow children to operate the mower in any manner or to ride as a passenger.

**NOTE:** The six examples are the most frequently cited injury causing situations. Please review all the safety precautions outlined on the following pages prior to operation of the mower. Our aim is to enhance the safe and satisfactory use of this product.

---

# SAFETY

## SAFETY REMINDERS: READ CAREFULLY BEFORE OPERATION

1. Wear appropriate, safe clothing when mowing - close fitting jeans or slacks and heavy leather or safety shoes with rough soles. Never operate this mower with bare feet or open sandals.
2. Do not operate on wet or slippery grass.
3. Always mow at the slowest speed that will cut satisfactorily.
4. Keep hands and feet away from the blade at all times.
5. Keep persons clear of the discharge chute. Do not operate mower unless deflector is in place.
6. When mowing hills or slopes, use extreme caution. Reduce speed, do not make sudden starts, stops or turns.
7. Always disengage blades before taking the mower across walks or objects that project above the surface.
8. Stay alert for holes, rocks and roots in the terrain, and other hazards. Keep away from drop-off s.
9. When the mower is not in use, turn the engine off and remove key. Never leave the engine running unattended. Your Dixon mower is equipped with a weight-sensitive switch that kills the engine when operator leaves the seat while blades are engaged.  
  
Note: This important safety feature must be tested prior to each mowing. This may be done by starting engine, engaging blades and then rising slightly from seat. If engine does not stop, see your dealer for necessary repair.
10. Before adjusting or servicing your mower, turn off the engine and let it cool. Be sure all moving parts are stopped. Never run the 560 with the body open.
11. Never run the engine indoors; the fumes are dangerous.
12. Before backing your Dixon Mower; stop, turn around and look.
13. Handle gasoline with care - it is highly flammable.
  - A. Use approved gasoline container.
  - B. Never remove the fuel cap of, or add gasoline to, a running or hot engine, or an engine that has not been allowed to cool after running. Never fill the tank indoors and always clean up spilled gasoline.
  - C. Never store the mower, with gasoline in the tank, inside the building where fumes may reach an open flame or spark. Allow the engine to cool before storing in any enclosure.

---

**SAFETY REMINDERS:** (Continued)

14. Never lift lawnmower by the body, lift only by the frame.
15. *Never carry passengers.*
16. Use care when pulling loads or using heavy equipment.
  - A. Use ONLY approved drawbar hitch points.
  - B. Limit loads to those you can safely control.
  - C. Do not turn sharply. Use care when backing.
17. Watch out for traffic when crossing or near roadways.
18. Keep the mower in good operating condition, and keep safety devices in place and working.
19. Keep all nuts, bolts and screws tight to be sure the mower is in safe working condition.
20. To reduce fire hazard, keep the engine free of grass, leaves or excessive grease.
21. The mower should be stopped and inspected for damage after striking a foreign object or if it starts vibrating, and any damage should be repaired before restarting and operating the mower.
22. When mowing, proceed as follows:
  - A. Mow only in daylight or in good artificial light.
  - B. Shut the engine off when removing the grass catcher or unclogging chute.
  - C. Check the blade mounting bolts for proper tightness at frequent intervals.
  - D. Never operate the machine when using medication or under the influence of alcohol or drugs.

---

# DIXON LIMITED WARRANTY POLICY -- HYDRO-GEAR MODELS

This warranty policy applies to all Hydro-Gear mowers or any 50" model, purchased on or after March 1, 1990.

WARRANTY: Dixon Warranty term is for a period of one (1) year from date of purchase or 400 hours of use, whichever occurs first. Mowers used for residential homeowner applications (used only at owner's primary place of residence) are warranted for two (2) years from date of purchase or 400 hours of use, whichever occurs first. DIXON ZTR MOWERS ARE WARRANTED AGAINST DEFECTS IN MATERIALS AND WORKMANSHIP AND PROVIDES FOR REPLACEMENT OR REPAIR OF PARTS INCLUDING LABOR COSTS. THIS WARRANTY IS SUBJECT TO THE FOLLOWING CONDITIONS AND LIMITATIONS:

1. Warranty applies only to original retail purchaser of new and unused mowers and accessories.
2. All Dixon warranty must be accomplished by authorized Dixon dealers and in accordance with Dixon warranty policy and allowances. All warranty claims must be approved by Dixon Industries, Inc.
3. Battery warranty: Limited to 90 days from date of purchase.
4. Accessories Warranty (Grass Catchers, Snow Blades, Tine Rakes, Covers, etc.): Limited to 90 days from date of purchase.
5. Warranty does not apply to damage in transit or incidents of misuse, negligence, accidents, or alteration. The use of parts or components other than those supplied by Dixon Industries, Inc. VOIDS ALL WARRANTY.
6. The following items are not covered by this warranty policy:
  - (a) Pick up and delivery charges for transportation of mower to and from an Authorized Dixon Dealer's place of business.
  - (b) Routine maintenance or adjustments.
  - (c) Belts / chains / sprockets / cutting blades.
  - (d) Engines -- All engines used on Dixon ZTR mowers are warranted by each individual engine manufacturer.
  - (e) Any costs or expense of providing substitute equipment while repair work is being performed on a warranted mower.
7. There is no other express warranty. Implied warranties, including those of merchantability and fitness for a particular purpose, are limited to the same duration of the express warranty, and to the extent permitted by law any and all implied warranties are excluded. Liabilities for consequential damages under any and all warranties are excluded.

WARRANTY VALIDATION: At the time of sale, selling dealer must review each portion of this warranty document, complete the information section below, secure customer's signature and send copy to Dixon Industries, Inc.

DATE OF PURCHASE _____	Model _____	S/N _____	DM- _____
_____ (Owner's Name)		_____ (Dealership)	
_____ (Address)		_____ (Address)	
_____ (Owner's Signature)		_____ (Dealer's Signature)	

**SEE DEALER FOR DETAILS**

---

---

# SPECIFICATIONS

CHASSIS:	11 GA - rectangular tube.
BODY:	Two piece - made of rotational molded polyethylene. Front body contains access panels for battery service and engine to mower deck belt removal. Rear body tilts up to allow service on the entire drive system.
SEAT:	Economically designed for operator comfort by use of high density closed cell foam, contoured back rest and arm rests. Seat is adjustable fore and aft.
MOWER DECK:	11 GA stamped steel construction, 3 blades, 60" cut width, cut height 1 " to 4" via 7 position lift handle. Self cleaning design, aides discharge of grass.
BLADE DRIVE:	Electric clutch.
DRIVE SYSTEM:	<p>Each rear wheel is independently driven by a Hydro Gear BDU-10L Series 70 hydrostatic transmission. The hydrostatic transmissions, in turn, power a fully enclosed Hydro Gear gearbox. The gears in the Hydro Gear gearbox are permanently lubricated using a special grease which completely eliminates the need for any type of maintenance.</p> <p>The Hydro Gear BDU-1 OL Series 70 hydrostatic transmissions are serviced with any high quality 10W-30 motor oil. The oil is filtered by a 10 micron oil filter. Recommended service interval for filter is after the first 250 hours of operation, then after every 400 hours of operation. If the system becomes contaminated by dirt or other foreign debris, both oil and filter must be replaced immediately.</p>
ENGINE:	20 HP Kohler Magnum, 4-Cycle, air-cooled, gasoline, vertical shaft, twin cylinder opposed, aluminum crankcase, removable cast-iron cylinder barrels, L-head.
STARTING SYSTEM:	Electric by key switch operation with safety interlocks on parking brake and blade drive clutch.
TIRES:	Front 11 X 4.10 X 4 ribbed tread. Rear 20 X 1 0 X 8 turf savers.
CAPACITIES:	Fuel - 4.8 gallons total (dual tanks). Hydrostat oil tank - 3 quart with inline 10 micron filter. Hydrostat oil recommendation - name brand SAE 10W-30 motor oil.
DIMENSIONS:	Width 72" Height 45" Length 73 1/2" Weight 685 lbs.
NOTE:	Additional information provided in service instructions under the individual component.

**SPECIFICATIONS SUBJECT TO CHANGE WITHOUT NOTICE.**



---

## **SET UP AND SERVICE**

1. Seat Assembly Instructions
2. Upper Control Lever Installation
3. Mower Deck Installation
4. Deck Leveling
5. Final Preparation

# SEAT ASSEMBLY INSTRUCTIONS

1. Place seat back against frame of seat bottom. Align top & bottom holes in frame with the t-nuts in seat back. Insert (4) 1/4-20 Phillips machine screws to attach frame to seat back. DO NOT TIGHTEN SECURELY.
2. Place (1) armrest bracket against seat back, aligning mounting holes in bracket and seat back.
3. Insert (2) 5/16-18 X 5/8" tapping screws through holes in bracket & frame and start screw threads. DO NOT TIGHTEN SECURELY.
4. Insert (1) 1/4-20 X 3/4" Phillips machine screw through remaining hole in bracket and start screw threads. DO NOT TIGHTEN SECURELY.
5. Repeat steps 2 through 4 for the other armrest.
6. Tighten all screws.
7. Align back cover to seat back. Secure with (4) #14 X 5/8" wood screws and (4) 5/16" SAE washers in recesses provided.
8. Slide armrest onto mounting bracket pin.
9. Insert set screw in rear of armrest, securing armrest to mounting bracket.
10. Repeat steps 8 & 9 for other armrest.
11. Center utility box on seat back cover and fasten with drill & tap screws and washers provided in separate hardware package.

DET	QTY	P/N	DESCRIPTION
1	1	8406	LEFTBRACKET
2	1	8407	RIGHTBRACKET
3	2	8408	ARMREST
4	1	8409	BACKCOVER
5	1	8410	SEATBACK
6	2	-	3/8-16x3/4" SET SCREW
7	4	-	5/16-18 HEX HEAD TAP SCREW
8	6	-	1/4-20 PHILLIPS MACHINE SCREW
9	4	-	5/16" SAE WASHER
10	4	-	#14 x 5/8" WOOD SCREW
11	1	4256	UTILITY BOX
12	4	3008	1/4" ID x 3/4" OD FLAT WASHER
13	4	3356	#12-14 x 3/4" DR & TAP SCREW
14	1	8414	SEAT BOTTOM FRAME

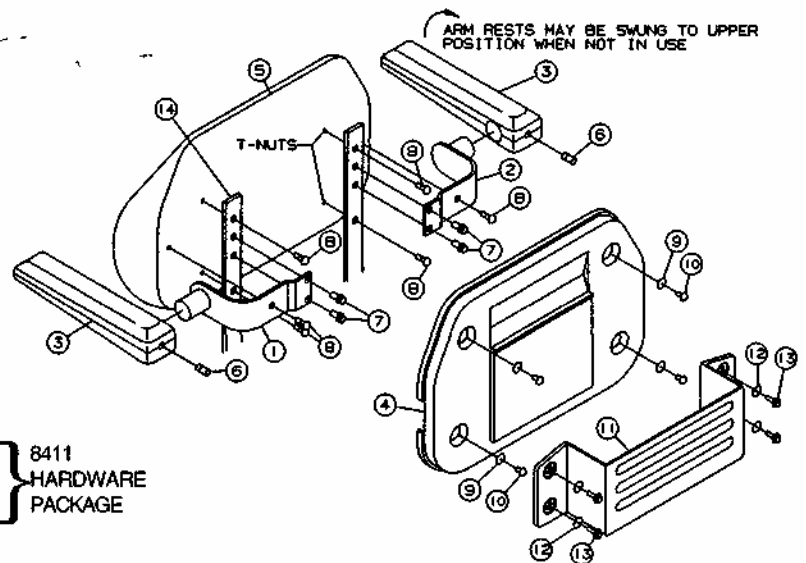

## SEAT ASSEMBLY INSTRUCTIONS:

DET	QTY	P/N	DESCRIPTION
15	2	1834	SEATSTRAP
16	2	3359	5/16-18x3" HHB ALL-THREAD
17	2	3360	5/16-18x4" HHB ALL-THREAD
18	4	3248	5/16 ID x 1/8" THICK WASHER
19	8	3205	5/16-18 HEX NUT W/NYLOK
20	4	3362	5/16-18x1" TAPPING SCREW
21	4	1849	SEATSPACER
22	4	3020	5/16 STD FLAT WASHER
23	2	3874	SEAT KNOB 5/16-18

12. Install all-thread hex head bolts into seat straps. Place (1) 5/16-18 x 3" bolt through hole located 1-5/8" from end of strap. Place (1) 5/16-18 x 4" bolt through hole located 2-7/8" from opposite end of strap. Secure each bolt to strap using (1) 1/8" thick washer and (1) 5/16-18 hex nut w/nylok. See illustration. Repeat procedure for other seat strap.

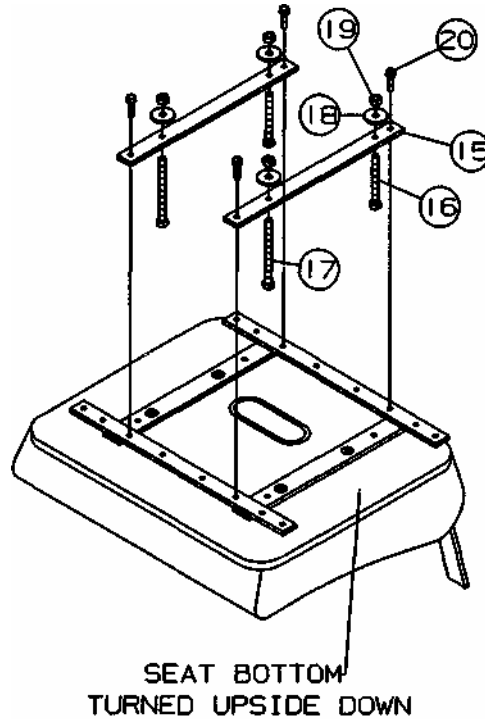

13. Attach seat straps to seat bottom as illustrated. The 3" stud protruding through strap must be located near the rear of seat while the 4" stud should be nearest the front edge of seat. Align remaining seat strap holes with holes in bottom of seat as shown, and attach seat straps using (4) 5/16-18 X 1" tapping screws.

14. Place seat assembly on body, and *connect safety switch.*

15. Place (1) seat spacer (1849) on each stud protruding through seat bottom, and insert studs through slots in body. Firmly hold seat assembly against body with one hand while body is raised to fully open position. Continue to hold seat against body to prevent damage to seat safety switch wiring.

16. Install (1) 5/16 standard flat washer (3020), (1) seat knob (3874), and (1) nylok nut (3205) on each of the front studs extending through body and seat frame, and tighten these nuts.

17. Install (1) 5/16 standard flat washer (3020) and (1) nylok nut (3205) on each of the rear studs. Do not fully tighten these nuts, thus allowing for easy slide action of seat, as provided by knobs on front studs.

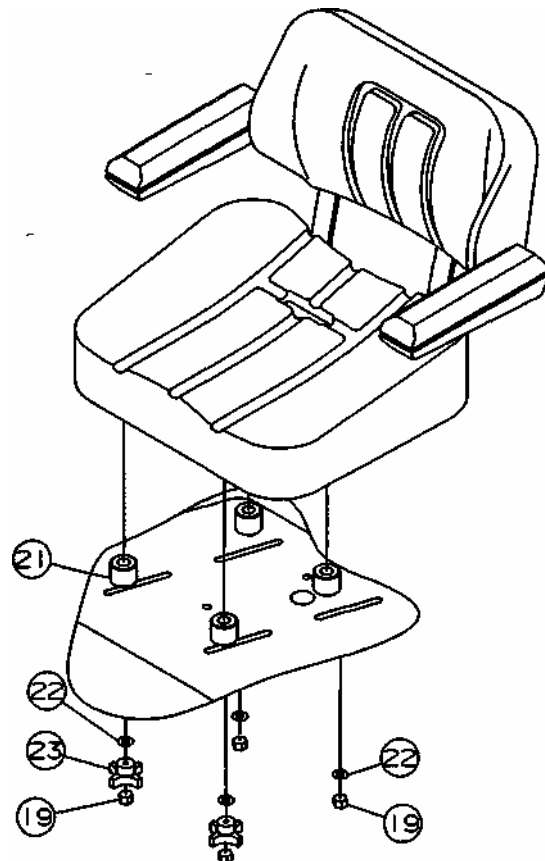

---

## UPPER CONTROL LEVER INSTALLATION

1. Raise rear body cover to fully open position.
2. Install flat washer on right hand swivel plate weldment. Next install right hand control lever, then second flat washer.
3. Push control lever into the neutral slot and install (2) cup washers, (1) flat washer and jam nut. (See illustration)
4. Tighten jam nut. Proper tightness or tension on jam nut is achieved when swing out movement of upper control levers requires some pressure. Levers should not fall to the side or be sloppy in movement.
5. Repeat above procedure on left side.

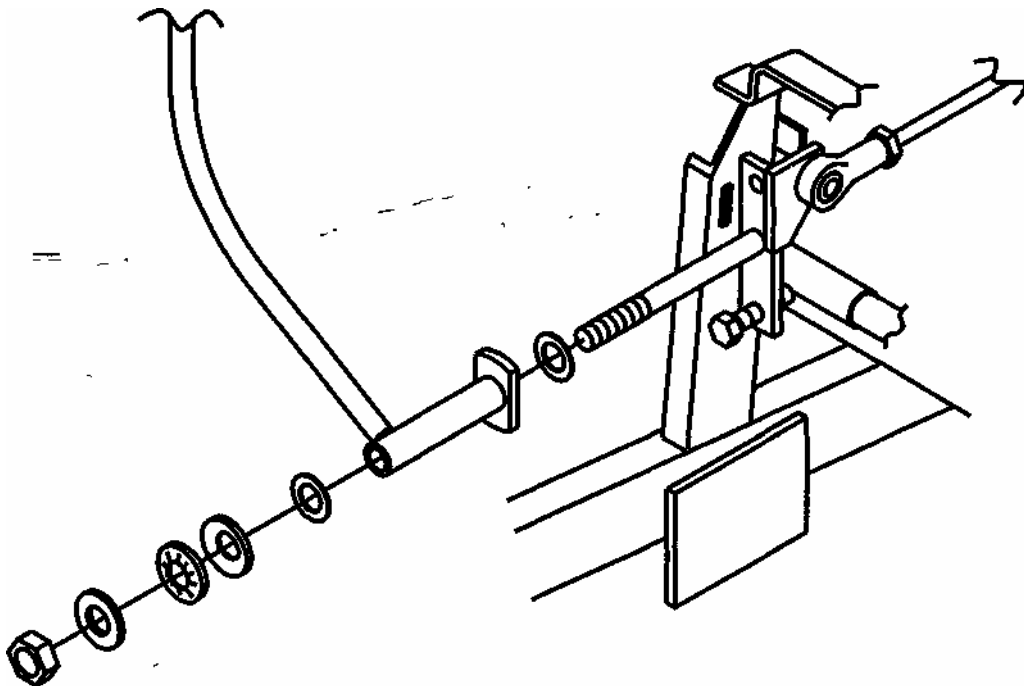

## MOWER DECK INSTALLATION

**NOTE:** Brake link (P/N 5283) normally used for installation of engine to mower deck drive belt, has been placed in position during assembly of the lift frame at the factory. For shipment purposes, the brake link has been secured with a cotter pin and washer. REMOVE AND DISCARD cotter pin and washer after engine to mower drive belt has been installed.

1. Loosen and remove front body mounting bolts (P/N 3368) and washers (P/N 3066). Disconnect headlight wiring plug from wiring harness. Lift front body from chassis.
2. Install rear hanger rods on lift frame. Slide lift plate on hanger rods, small holes in lift plate will face rear of mower, and start nylok nuts on each hanger rod until approximately 1/2 inch of threads are exposed.
3. Position mower deck under chassis.
4. Raise front of mower deck and slide front support rod through lift frame and tabs on mower deck. Install hair pin clips on front and rear of support rods.
5. Move lift lever to lowest cut position, install engine to mower deck drive belt on top center pulley. Check belt routing after installation to make certain that belt is centered in groove of electric clutch pulley.
6. Move lift lever toward high cut position and remove brake link from hole on lift lever.
7. Install front body, connect headlight wiring.

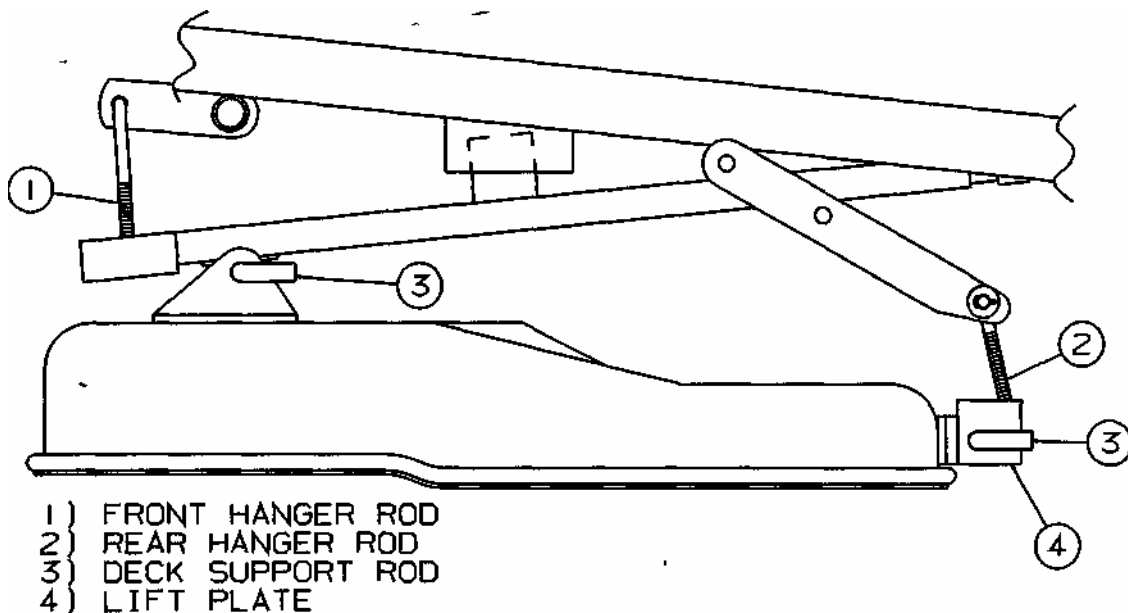

---

# MOWER DECK LEVELING PROCEDURE

## LEVELING PRINCIPALS:

- A. There are a total of (4) threaded adjusters which will control the attitude or pitch of the mower deck. The adjusters have lock nuts on the bottom which can be turned up or down to raise or lower the front and rear of the mower deck. Deck should be level or pitched slightly higher in rear.

## LEVELING THE DECK:

- A. Place the mower on a smooth level surface, check tire pressures to insure the mower has a correct stance. Inflate tires as required:
- Front -19 - 21 lbs maximum  
Rear- 10 -14 lbs maximum
- B. Rotate or turn each outer blade tip to align with the edge of the deck or side to side.
- C. Measure from the surface up to the bottom of the blade tip on the discharge side of the mower deck. Retain this measurement. Move to the opposite side, check that measurement is the same. If adjustment is required, turn the nut on the bottom of the front threaded adjuster up or down until both side to side measurements are equal. Retain measurement.
- D. Rotate or turn both outer blades to align with the deck in front to rear manner. Move to the left rear threaded adjuster, "left rear is designated from operator position on the mower". Turn adjuster nut up or down until rear of mower deck is positioned level to 1 /8th of an inch higher than the side to side measurement. At this time, the mower deck will hang or be suspended on (3) points. Move the right rear adjuster and take out the slack which will be present by turning adjuster lock nut up. Confirm the measurement used on the left rear of the deck.

**NOTE:**This will place the mower deck in a base measurement position. Additional adjustment may be required to achieve desired cut for the type of grass or conditions being mowed.

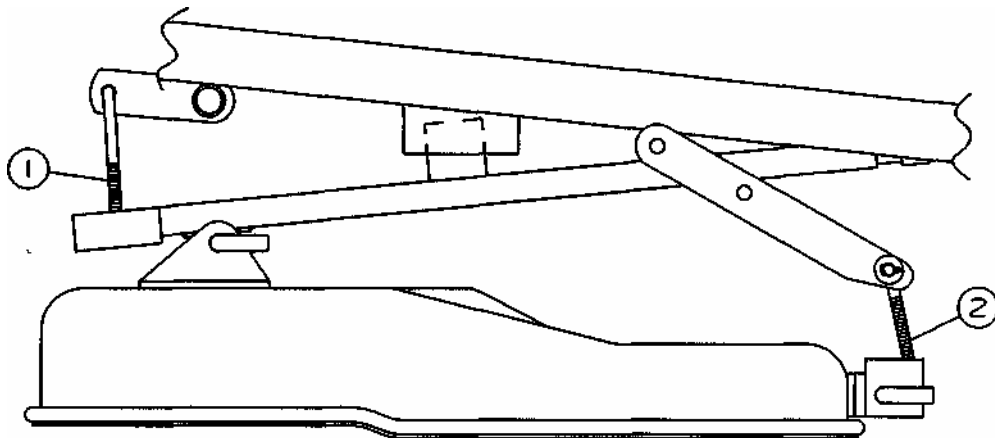

DECK LEVELING ADJUSTMENT POINTS

---

## **FINAL PREPARATION**

### **MOWER DECK DEFLECTOR:**

Remove hair pin cotter (P/N 3072) from deflector pin (P/N 6297), remove pin. Position deflector (P/N 8799) on mower deck. Reinstall deflector pin and hair pin cotter.

### **BATTERY:**

1. Remove battery from chassis.
2. Fill each cell with electrolyte (acid) to ring at bottom of fill cap.
3. Allow battery to sit for (10) minutes, re-check acid level and top off any cells that are low.
4. Trickle charge battery using a charger of less than (6) amps until all cells are gassing freely. Hydrometer readings may be taken, if desired.
5. Install permanent battery caps and wash any accumulated acid from battery before re-installation on chassis.
6. Observe proper battery polarity when re-connecting leads on chassis. Always connect positive lead first.

### **ENGINE SERVICE:**

Final preparation of engine should be completed using engine service manual provided - with mower.

### **INITIAL START AND HYDROSTAT TRANSMISSION CHECK:**

1. Final hydrostat checks have been performed at the factory, however, it is necessary to check that the pressure relief bypass on each hydrostatic transmission is completely released before attempting to drive mower.
2. Each hydrostat has a bypass relief pin located at the rear of the hydrostatic unit. A bypass keeper is provided to allow the mower to be rolled around without complete servicing of the unit. To accomplish this, the bypass keeper springs must be positioned to depress the bypass relief pins. Remove bypass keeper springs prior to actual operation of the mower.

---

## **OPERATION INSTRUCTIONS**

The safe and successful operation of the Model 560 will depend upon the operator having the correct knowledge of all controls used on the mower and making good judgements about the terrain to be mowed. *NEVER* allow anyone to operate the mower without complete knowledge of all controls and their functions.

Sound judgement by the owner will prevent accidents. All

controls are described from operators position:

### **PARKING BRAKE:**

The parking brake used on the Model 560 is designed to hold the mower from moving and is not intended for use in stopping the mower while it is in motion. An additional safety feature of the parking brake is that the engine cannot be started unless the brake is applied.

### **HYDROSTATIC DRIVE SYSTEM:**

Allows the mower to turn on its own axis (zero radius). Each lever controls one side of the mower. The pressure required to operate the mower is very light and a minimum of 112 hour should be spent simply driving the mower in a non-mowing application to gain the confidence necessary to mow like a pro.

### **LEVER MOVEMENTS:**

No shifting or clutching required.

### **TO GO FORWARD:**

Release parking brake. From neutral position, gently push both drive levers forward; to increase speed, move levers farther forward.

### **TO GO BACKWARD:**

From neutral position, gently pull both drive levers toward you.

### **TURNING:**

Turning is controlled by moving one drive lever slightly forward or rearward of the other. To turn left, move left lever rearward of the right lever. To turn "square corners" move lever of desired direction to neutral. To turn on mower's own axis (zero radius) reduce speed and move one lever to reverse position and the other to forward position.



## **OPERATION INSTRUCTIONS:** (Continued)

### **BRAKING:**

To brake mower, move both levers in direction opposite of travel, release levers to neutral, set parking brake. Park only on level surfaces.

### **GROUND SPEED:**

Ground speed (controlled by movement of hand levers) must be carefully controlled for safety and best mowing results. Never operate at high speed in unfamiliar areas or on slopes.

### **CHOKE CONTROL LEVER:**

Used to start a cold engine. (Engine has not been operated for a length of time). Located on control panel to operators right.

### **THROTTLE CONTROL LEVER:**

Controls engine speed, slow to maximum. Lever should be set to the maximum or wide open setting to insure adequate cooling of the engine and to maintain mower deck blade speed while mowing.

### **MOWER DECK CUT HEIGHT LIFT LEVER:**

Controls the cutting height of the mower deck. Seven positions of adjustment in which the very top, or highest notch, is used for transporting the mower in a non-mowing situation. Located in front of operator on the right side of mower.

### **BLADE DRIVE:**

To engage the mower deck cutter blades, lift switch up lightly and push forward. To disengage blades, pull switch backward. Switch is clearly marked "on and off".

### **CIRCUIT BREAKER:**

Protection of the electrical system is by (1) 15 amp circuit breaker. If circuit breaker engages, push button to reset. If this condition repeats, consult dealer for inspection and repair.

---

## **CARE AND MAINTENANCE - MODEL 560**

This portion of the Model 560 owners manual deals with normal service items which can be performed by the owner. Please remember that if you are in doubt as to the correct service procedures to be followed, these and other service situations can be handled by a Dixon ZTR Dealer who is familiar with the service of your mower.

**NOTE:** Due to the precision nature of the hydrostatic transmissions used on the Model 560, internal service repairs cannot be recommended. Current service requirements will necessitate replacement of an entire hydro unit if failure should occur.

### **MAINTENANCE SCHEDULE:**

To insure a long and trouble free service life on all the components used on the Model 560 a regular and thorough maintenance schedule should be followed. As with any type of precision made equipment, a certain amount of initial bedding in or seating of the components will take place. The following items should be checked after the first (10) hours of operation and on a weekly basis, or each (40) hours of use:

1. Drive system, belts and controls.
  2. Mower deck belts.
  3. Tire pressures.
  4. Hydrostat oil.
  5. Tightness of all nuts and bolts.
  6. Electric blade clutch air gap setting.
- \* Refer to Page 16 for details

Refer to engine service manual provided with your mower for maintenance schedules and procedures to be used on the engine.

# PROCEDURE FOR ELECTRIC CLUTCH ADJUSTMENT

Dixon has used two types of electric clutches. One type is the Borg Warner and the second one is the Ogura. Even though these clutches come from different manufacturers, the test procedures are the same for both. Few people realize that clutches have maintenance procedures to extend the life of the clutch as they wear over time. Below is the information to make these maintenance adjustments and also a procedure to check for a faulty coil. In the case that the clutch has failed a part, the entire clutch must be replaced since there are no parts available.

## A. AIR GAP ADJUSTMENT

1. Remove the clutch from the engine. This is recommended because it is easier to verify the gap.
2. Locate the three rivet joints which fasten the leaf springs to the armature (figure 1).
3. Rotate the pulley until these rivet joints are located midway along the edge of the triangular field adapter (figure 1).
4. Locate the three holes in the brakeplate, one near each adjustment nut (figure 2).
5. Insert a .012 inch feeler gauge into one of the three windows. Be careful to position the feeler gauge between the rotor and armature faces (figure 3).
6. Tighten the adjusting nut adjacent to the window with the feeler gauge inserted until the gauge fits snugly between the rotor and armature. The gap should not be so tight that the feeler gauge cannot be reinserted after removal.
7. Repeat Steps 5 and 6 at the other two windows.
8. Recheck the air gap at each window and make minor adjustments as necessary to achieve a consistent .012 inch air gap.
9. Reinstall the clutch to the engine. Be sure to torque the mounting bolt back to 50 ft. lbs.

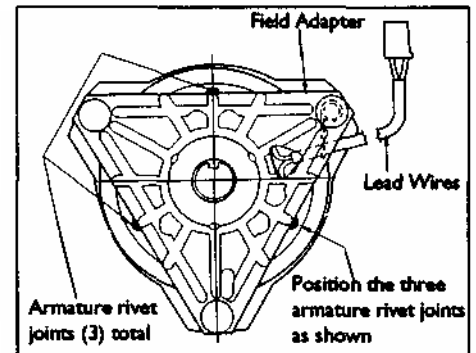

figure 1

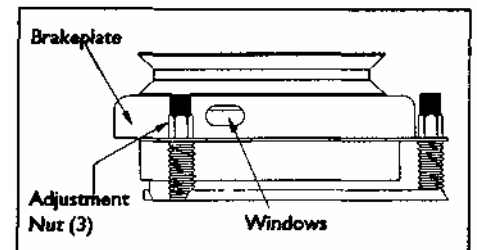

figure 2

## B. OHMS TEST:

1. Disconnect clutch from mower wiring harness which is located on the right side of the mower frame.
2. Set the multi-meter on RX1 and attach the two leads to the two wires coming from the electric clutch.
3. The reading you receive should be between 2.4 to 2.9 OHMS.
4. If the resistance is outside this range the clutch coil is faulty.
5. If the clutch coil is faulty, the clutch must be replaced.

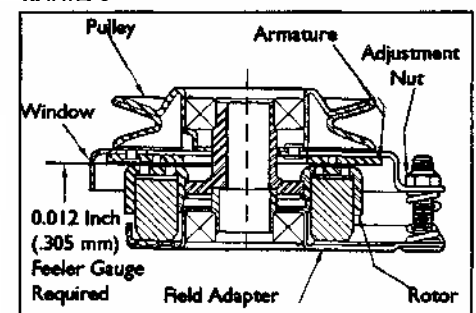

figure 3

---

# **CARE AND MAINTENANCE - MODEL 560**

## **MOWER DECK SERVICE**

### **CUTTER BLADE REMOVAL - BELT TENSION:**

**"CAUTION"** The removal of the cutter blades for either sharpening or replacement is best accomplished by removing the deck assembly from the mower. *DO NOT* attempt to raise or lift the front of the mower unless proper safety equipment is available to support the mower. If you do not have the necessary equipment, entrust this task to your dealer.

### **DECK REMOVAL:**

1. Remove front belt access cover from body. Stand in front of mower, grasp lift quadrant lever with left hand. Move lever to align with the 5th hole from the bottom on the quadrant plate. At this time, connect brake link into hole on lift lever. Move lift lever toward lowest cut position and remove belt from the top of center deck hub assembly.
2. Remove the hair pin cotter pins from the ends of the deck support rods. Slide deck support rods from deck while supporting deck assembly with a suitable brace, or by the use of an assistant to hold the deck while rods are removed. Slide deck from under chassis.
3. Reverse procedure to re-install deck assembly.

### **CUTTER BLADE REMOVAL:**

1. Carefully place deck assembly in a manner which will allow access to the blade bolts. Hold blade from turning while bolt is removed from the center of each hub assembly. *"Caution"* wear heavy, thick gloves when holding onto cutter blade, avoid the sharp edge of the blade.
2. When reassembling blades to hub assemblies, fully tighten blade bolts to a minimum of 50 ft. lbs. torque. The use of air impact tools is recommended for installation to insure bolt tightness.

### **BELT TENSION:**

1. The engine to mower deck drive belt on the Model 560 is automatically held in proper tension by springs which push the deck assembly forward, and does not require any additional adjustment to be made. Both the belt and the idler system should be periodically inspected due to the nature of the job they perform.
2. Serpentine deck belt tension is maintained by a manual adjustment rod which is located on the top of the mower deck assembly. Proper belt tension is critical to insure cut quality. If adjustment is required, tighten lock nut on adjustment rod until belt free play or movement between pulleys is approximately 1/4 of an inch.

---

## **CARE AND MAINTENANCE - MODEL 560**

### **DRIVE SYSTEM ADJUSTMENTS:**

Adjustment of the drive system is limited to the actual function of the hydrostatic transmissions as outlined below.

1. Tighten the (2) J-bolts on the T-box mounting plate until each belt has 1/8th to 1/4th of an inch free play or movement at a mid-point between the pulleys on the hydrostats and T-box.
2. Position parking brake lever in the off or disengaged position. This will allow the belt idler used on the engine to T-box to swing fully and apply tension to the belt. At this time, check that the cable which pulls the idler to a neutral position has approximately 1 -1/2 to 2 inches of free play. If adjustment is required, loosen the lock nuts on the cable block and turn cable sleeve in or out to achieve desired measurement. Re-tighten lock nuts.

NOTE: Cable must have the above dimension with parking brake released or drive belt may slip, causing loss of power.

3. Neutral adjustment. Swing upper control levers out into the neutral slots. Raise upper body to the fully open position. Start engine and disengage parking brake. Caution should be used when releasing parking brake as mower may tend to creep or move prior to adjustment. If adjustment is required, loosen lock nuts at each end of the control rods and back off the tension on each spring block. Turn control rods in or out until neutral is obtained on each hydrostat. Re-tighten lock nuts and tension bolts on spring blocks.
4. Forward travel speed adjustments. Stop engine, move levers to drive position, lightly push each upper control lever forward until a resistance is felt on the lever. At this time, check that the forward lever stops on the bottom of each lever are hitting the stop blocks. If adjustment is required, loosen the lock nuts on the lever stop and turn the bolt in until the lever hits the stop block before resistance is felt in the hydrostat.
5. Balance of travel speed. If mower tends to pull to either side, re-adjust lever stop on fast side to slow the hydrostat down and even out the ground speed. **DO NOT SPEED UP THE SLOW SIDE, AS OVER STROKING OF THE HYDROSTAT COULD RESULT IN DAMAGE TO THE UNIT.** If upper control levers are slightly off-set following this adjustment, they can be realigned by bending them slightly.

Refer to the diagrams on the following page for the location of adjustment points.

---

① ADJUSTMENT POINTS FOR T-BOX BELT TENSION

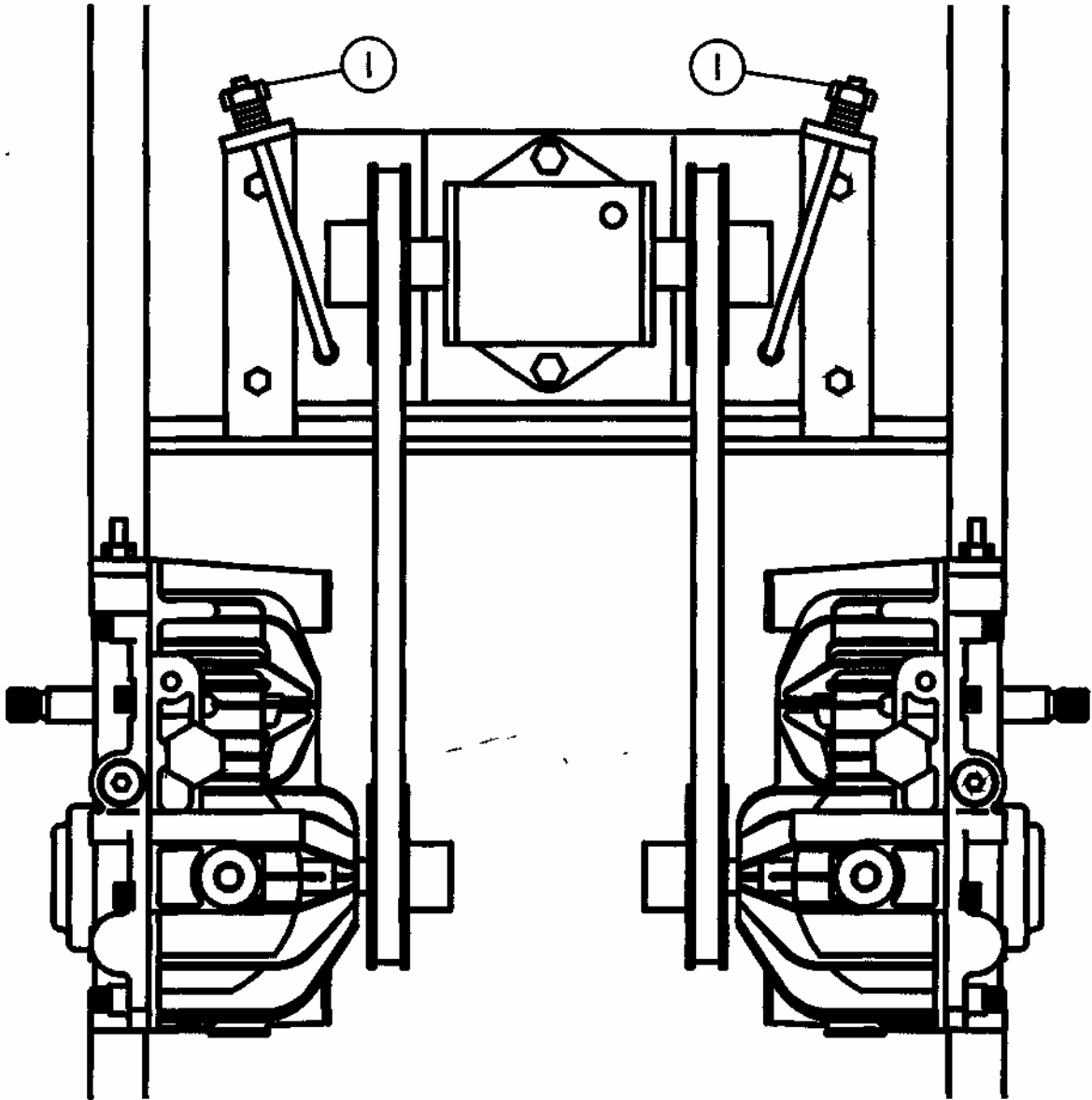

---

①

FORWARD LEVER STOP ADJUSTMENT

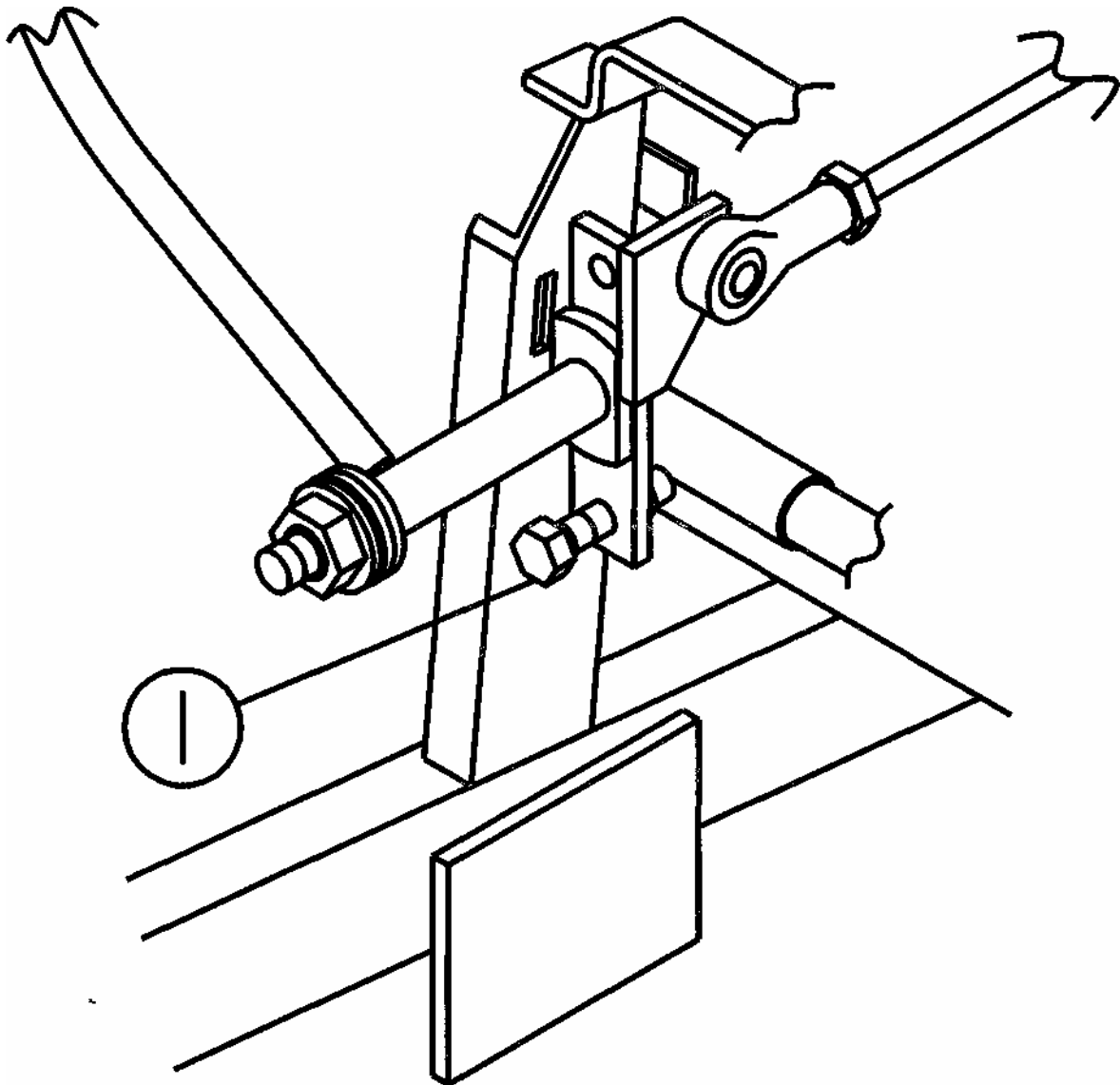

---

## **CARE AND MAINTENANCE - MODEL 560**

### **LUBRICATION:**

**CHASSIS AND MOWER DECK:** Number of grease zerks used: (7)

**LOCATIONS:** (1) each front wheel caster, front wheel, and deck hub for front wheels

**SERVICE INTERVALS:** Every 50 hours of operation

**RECOMMENDED GREASE:** Name brand wheel bearing or multi-purpose grease

**CAUTION:** The use of compressed air pressure greasing methods is not recommended as damage to seals and bearings could occur.

Using a hand pressure grease gun, lubricate each front wheel to allow even distribution of grease within the wheel, rotate or spin each front wheel after (3) pumps of the grease gun. Repeat process until the appearance of grease is noted completely around each caster axle.

**ENGINE OIL CHANGES:**  
**OIL RECOMMENDATIONS:**  
**SERVICE INTERVALS:** "Refer to separate owners manual furnished by the engine manufacturer."

*PLEASE DISPOSE OF USED OILS AT PROPER COLLECTION CENTERS.  
PROTECT YOUR ENVIRONMENT*



---

## CARE AND MAINTENANCE - MODEL 560

### CLEANING THE MOWER:

A clean machine is a source of pride to the owner. However, cleaning by use of high pressure commercial washes is not recommended. The high water pressure, combined with solvents or alkaline detergents, can lead to corrosion of electrical components or damage to the sealed bearings used on your mower. A better approach is the use of the mild household soaps and low water pressure. A stiff brush can be used to loosen excess grass and dirt build up. Avoid directing water pressure onto the mower deck hub assemblies, electrical wiring and engine components such as air filter openings. To remove excess water which accumulated during washing of the mower, either blow off with compressed air, if available, or start the engine, allowing a long enough operation time to dry thoroughly. It is advisable to engage the mower deck for a short time to disperse all water from pulleys and belts.

*PLEASE HELP PROTECT THE ENVIRONMENT BY AVOIDING ALL CHEMICALS WHICH MAY DAMAGE OR CAUSE HARM TO PLANTS AND ANIMALS IN YOUR AREA.*

---

# TROUBLESHOOTING

## **MOWER CUT QUALITY:**

There are many variables that can effect the cut quality of any multi-blade mower. Type and conditions of grass, cut height setting, engine RPM and ground speed are some of the variables that interact creating differences in cut quality. Examination of one or more of the above will generally produce a quality cut.

The Troubleshooting Chart suggests practices and adjustments that may be helpful in improving cut quality. Your Dixon ZTR Dealer is also available to provide assistance to you.

<u>SITUATION</u>	<u>CAUSES</u>	<u>REMEDY</u>
Poor cut quality	Ground speed	Reduce mowing speed
Poor cut quality	Loose belts	Adjust per operators manual
Poor cut quality	Engine RPM too low	Increase engine RPM to maximum
Poor cut quality	Dull or bent blades	Sharpen or replace as required
Poor cut quality	Unlevel mower deck	Adjust per operators manual
Poor cut quality	Grass build-up under mower deck	Clean out underside of mower deck
Poor cut quality	Improper blades	Replace with original equipment blades which are designed for the Model 560
Poor cut quality	Uneven tire pressures	Check and adjust as required per operators manual

---

---

# TROUBLESHOOTING

## DRIVE SYSTEM:

SITUATION	CAUSES	REMEDY
Mower pulls to one side or the other	Drive adjustment	Adjust per operators manual Consult your dealer for repair
Loss of drive power on one side or the other	T-Box belts slipping	Adjust per operators manual Consult your dealer for repair
Loss of power on both wheels after being operated for a length of time	Belt from engine to T-Box is slipping	Adjust per operators manual Consult your dealer for repair
Poor driving performance	Operation of mower	Review operators section of owners manual
Oil leaks	Loose or missing hose clamps	Tighten or replace as required

---

# TROUBLESHOOTING

## ELECTRICAL SYSTEM:

SITUATION	CAUSES	REMEDY
Starter will not turn engine over	Circuit breaker engaged	Push button to reset Consult your dealer for repair
Starter will not turn engine over	Dead battery	Charge battery
Battery discharge	Poor connections on battery Battery water low Wrong battery installed in mower	Tighten or replace as required
Battery discharge	Engine electrical system not functioning correctly	Have electrical system checked by your dealer
Battery discharge	Engine being operated at too low an RPM	Increase engine RPM Contact your dealer for information
Electric clutch will not engage mower deck blades	Low battery condition Poor connections on clutch switch Broken wiring	Repair or replace as required Consult your dealer for repair

NOTE: Electrical system failures are generally simple in nature, always check the obvious first and then move onto the more complicated parts used. Poor battery service, loose connections, corrosion, frayed or broken wiring, are more likely than component failure.

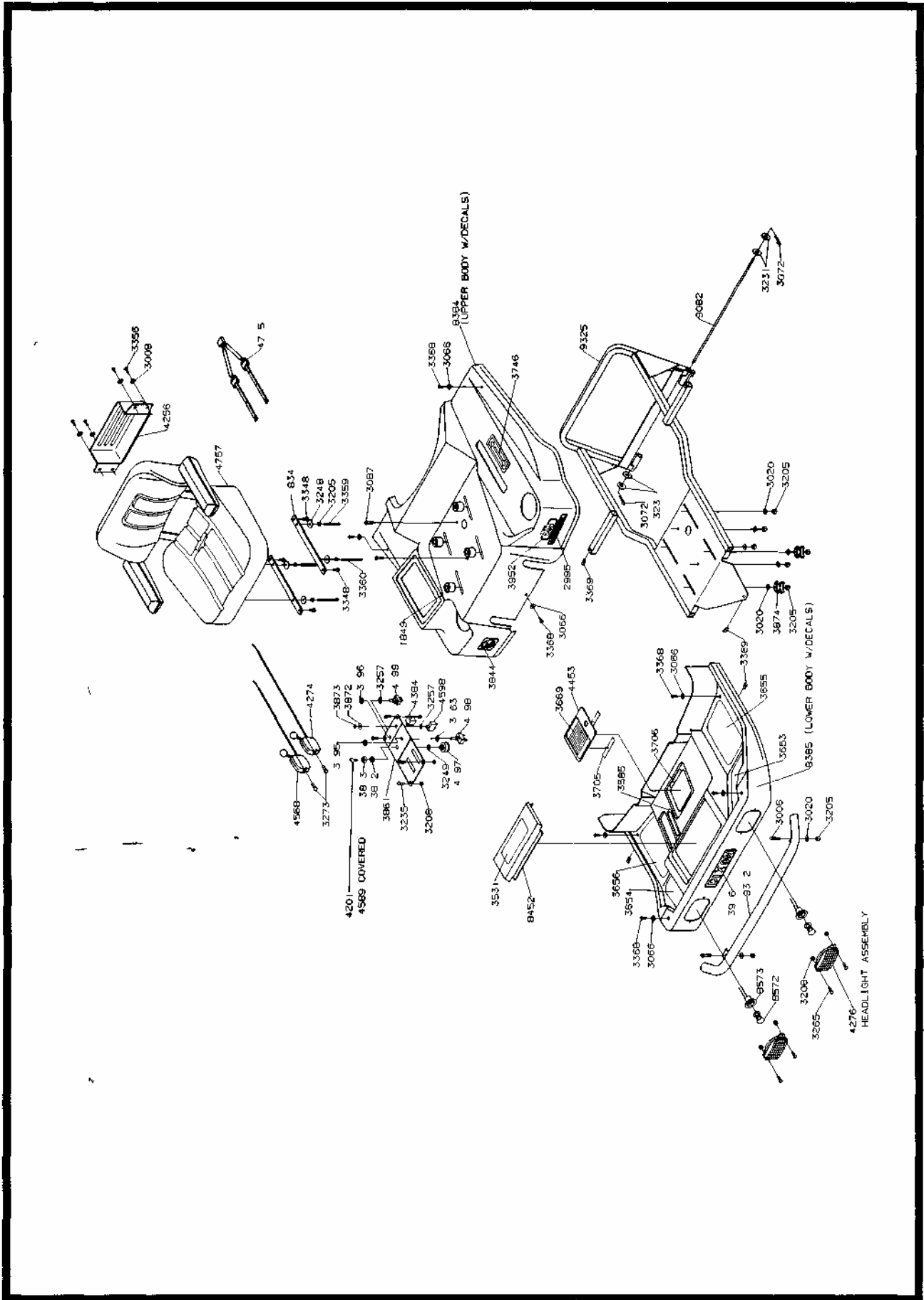

560 Body Assembly

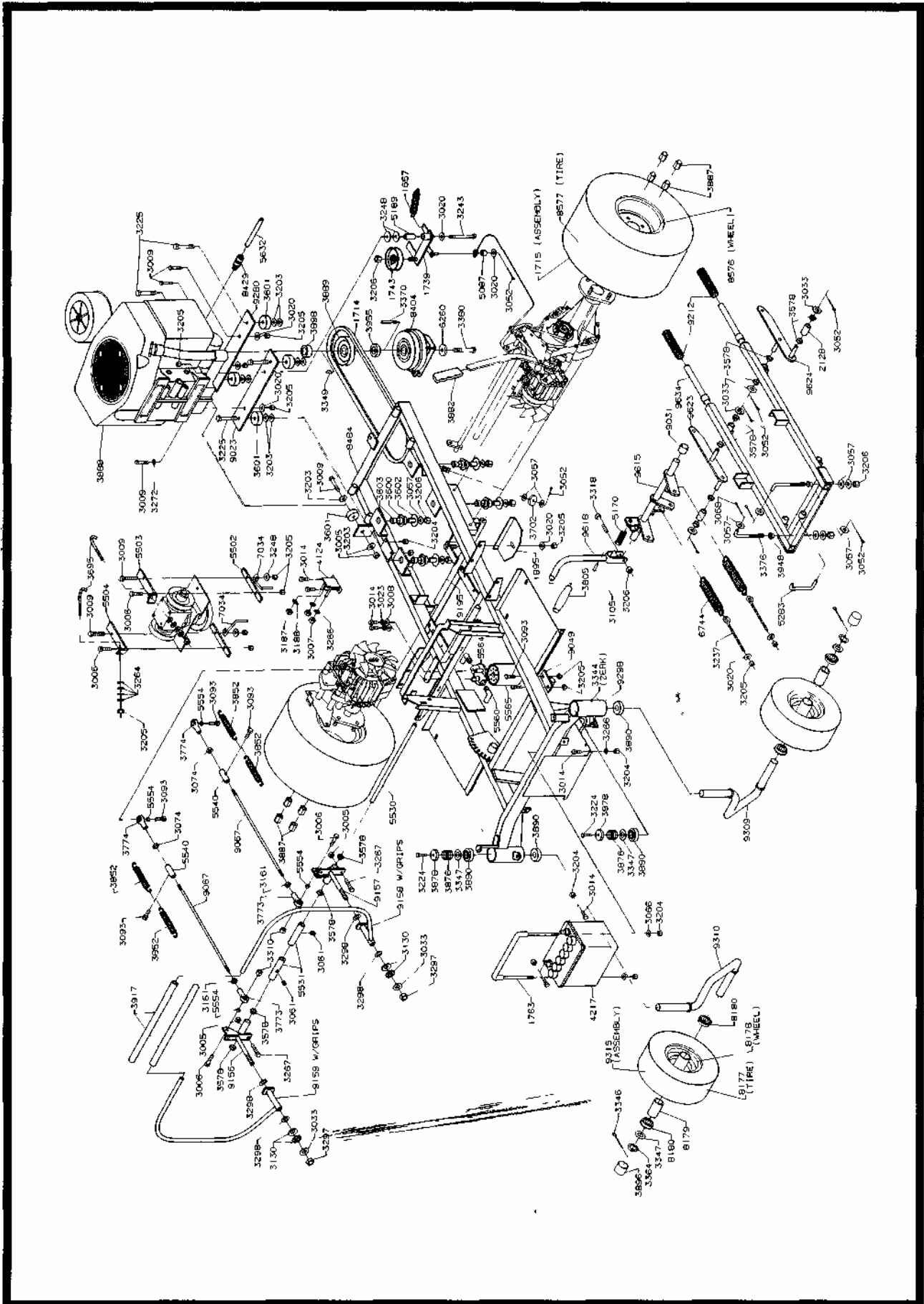

560 Chassis Assembly

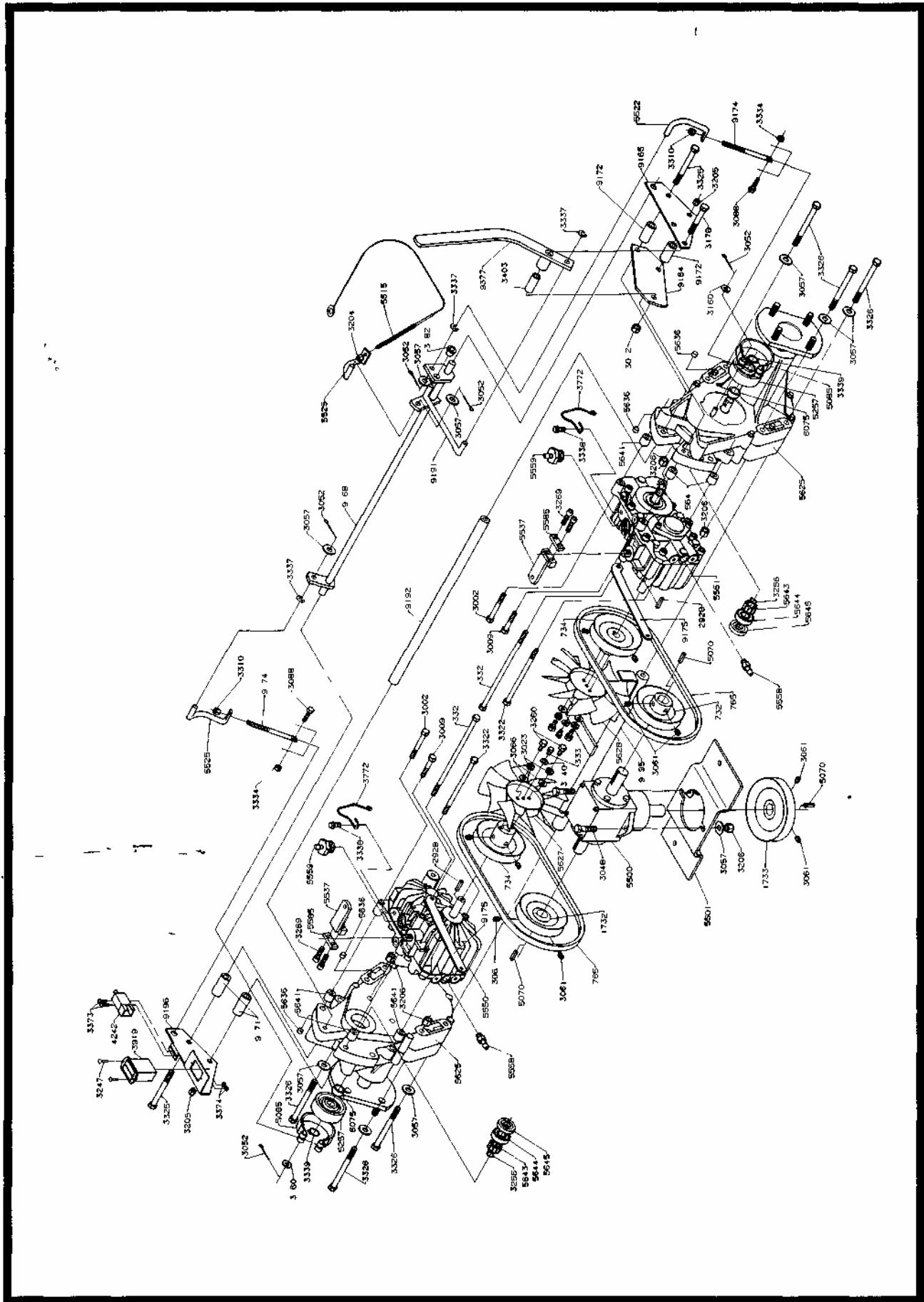

560 T-Box, Gearbox and Hydrostats Assembly

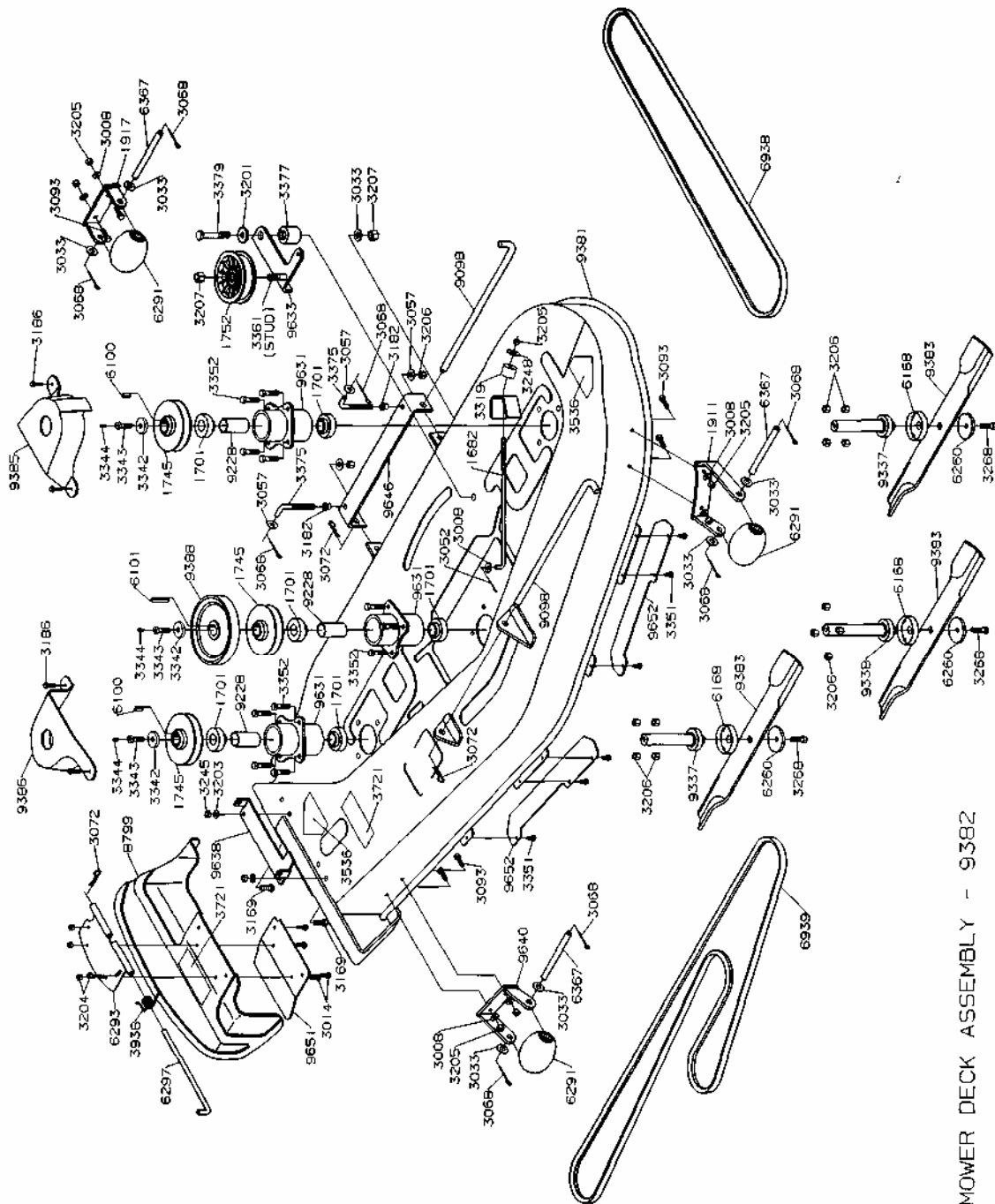

MOWER DECK ASSEMBLY - 9382

560 Mower Deck Assembly 60"



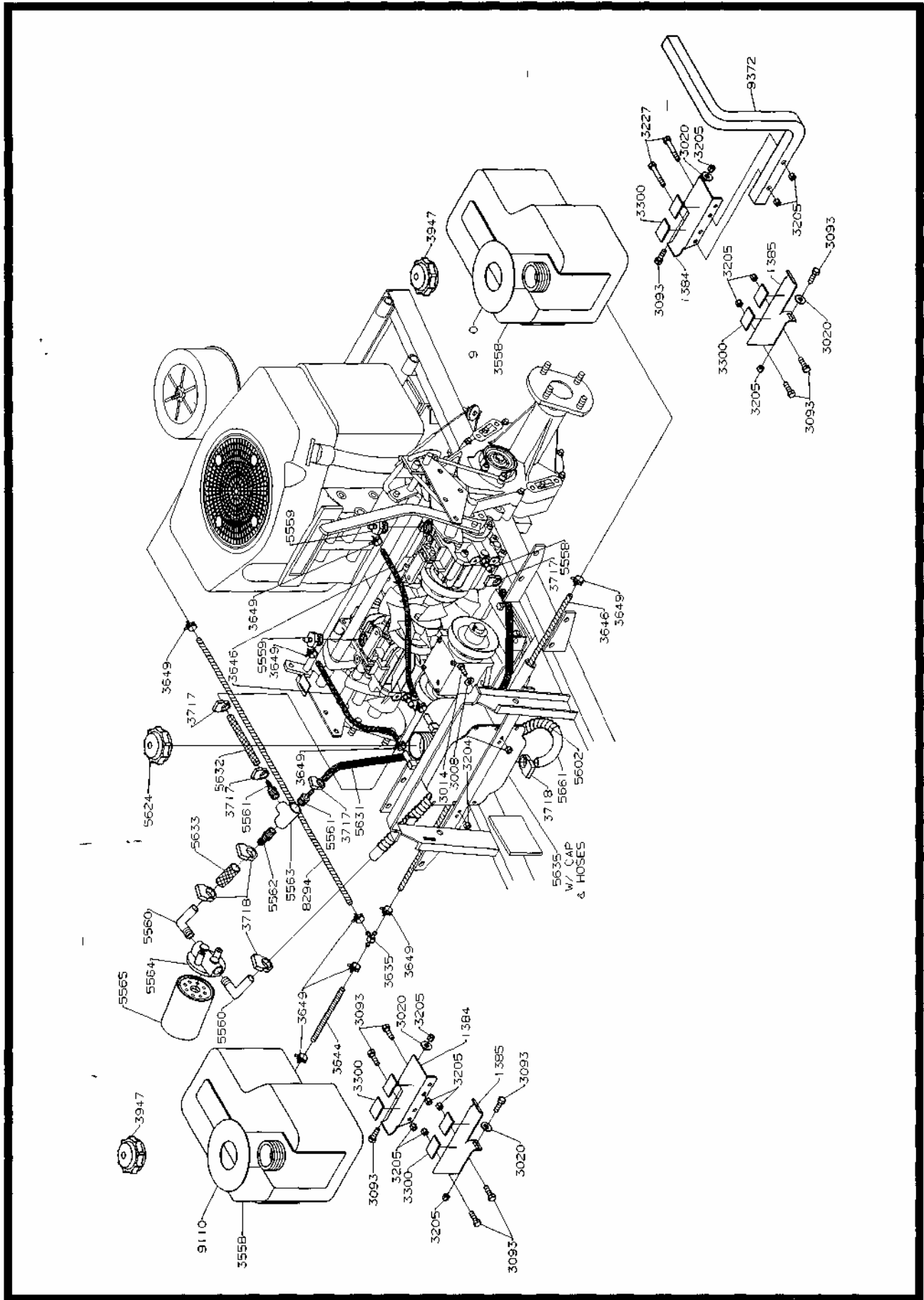

**560 Fuel and Hydraulics Tanks and Fitting Assembly**

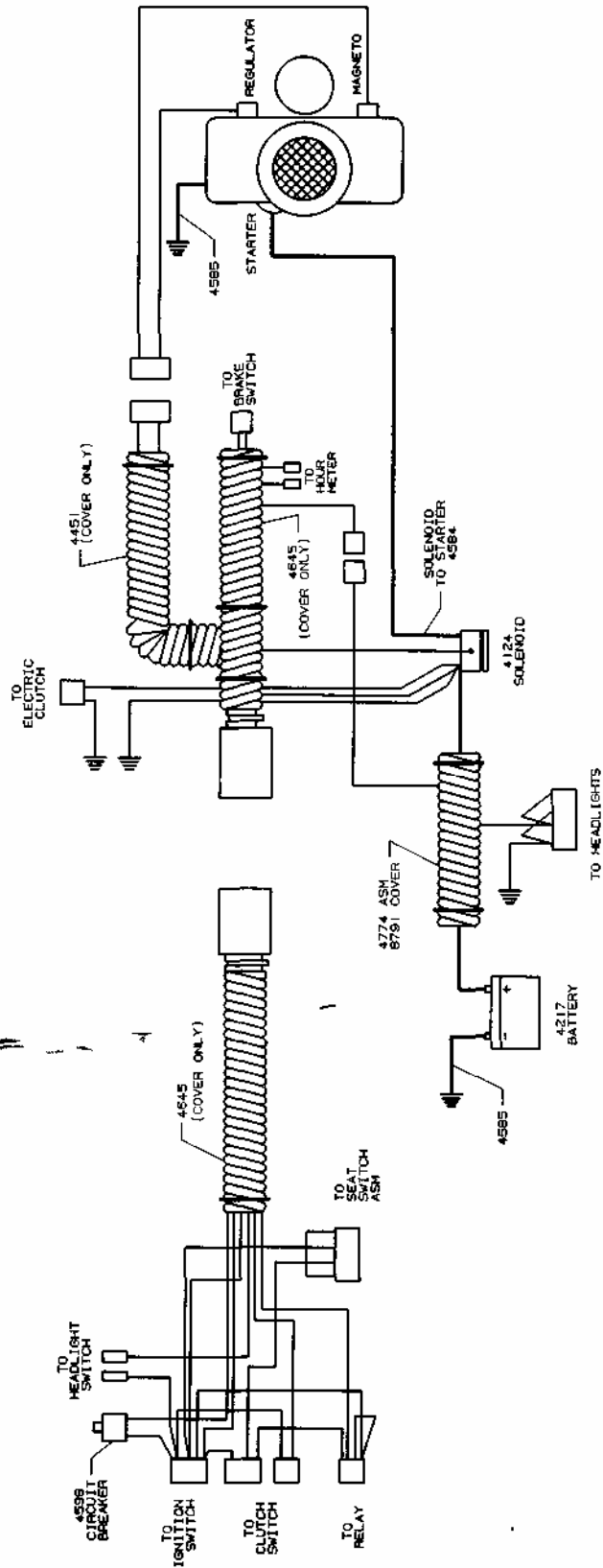

LOWER WIRING LOOM - 4773

UPPER WIRING LOOM - 4728

WIRING KIT - B387

**560 Wiring Assembly**

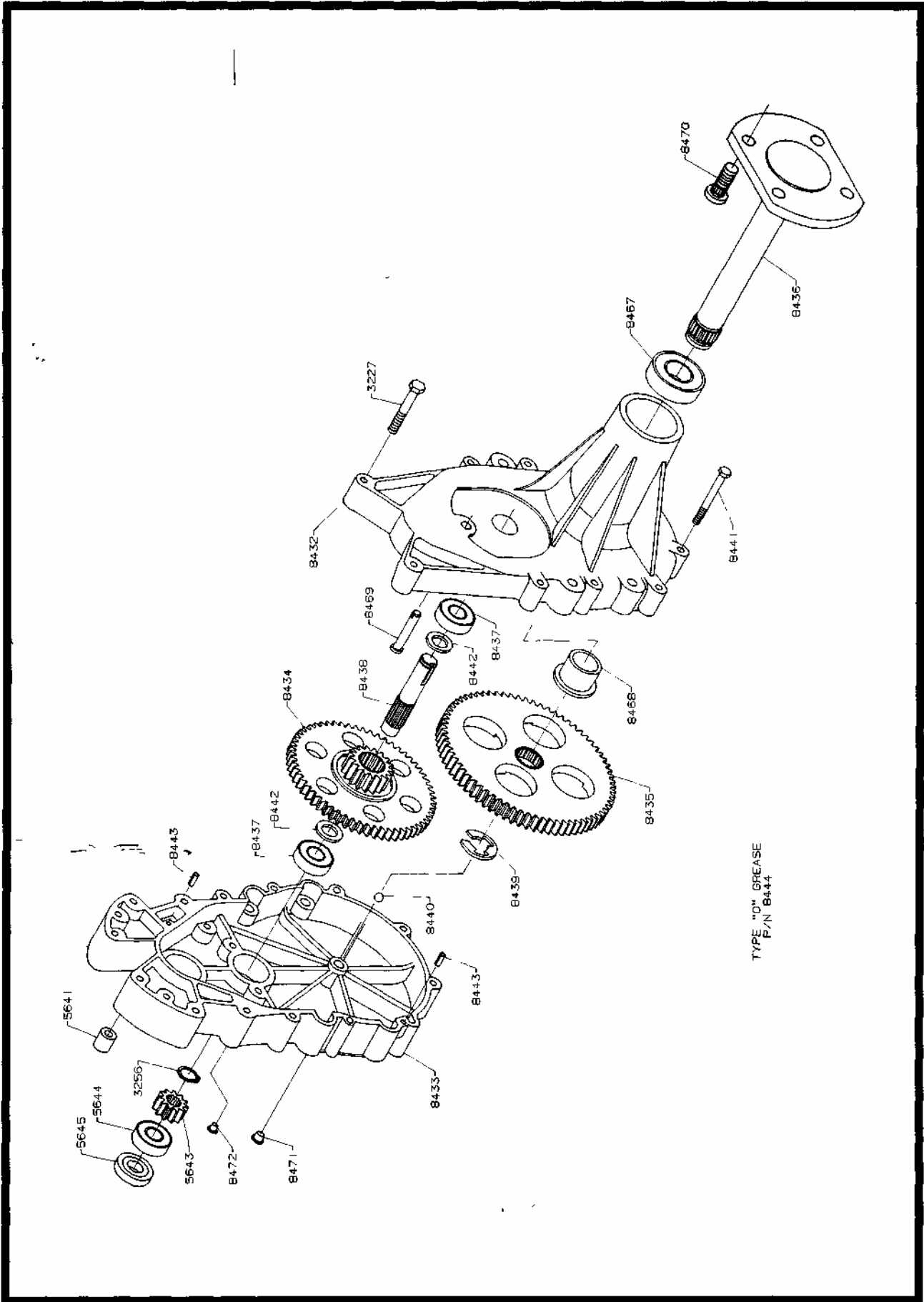

**500 Series Gearbox Assembly**

## ZTR 560 PARTS LIST

1384	Tank Mount Bracket (Short)	3093	5/16"-18 UNC X 1" HH Bolt GR5
1385	Tank Mount Bracket (Long)	3105	1/4" x 1 1/4" Spirol Pin
1657	Spring - Belt Idler	3130	1/2" Contact Belleville Spring
1682	L-Rod	3140	1/4" ID Disc Spring
1701	Wheel/Deck Hub Bearing	3160	5/16" Flat Washer
1714	T-Box Drive Belt	3161	5/16"-24UNFLH Thread
1715	Rear Wheel & Tire	3163	1/2" Int Tooth Lock Washer
1732	Pulley - T-Box	3169	3/8"-16X1"HHBoltGR5
1733	Pulley - T-Box Drive	3178	3/8"-16X2 1/2" HH Bolt GR5
1734	Pulley - Hydrostat	3182	Flip Lock Bushing
1739	Hydrostat Idler Bracket	3186	#12-14 X 1" Drill & Tap Screw
1743	Hydrostat Flat Idler Pulley HD	3187	#10-32 Hex Nut
1745	Pulley	3188	#10 Ext Tooth Lock Washer
1752	Plastic Idler 4" Flat	3195	Face Nut 1/2"-27
1763	Tie Down x/Insulator	3196	Face Nut 7/16"-28
1765	V-Belt	3201	Washer .533 ID X1. 37 OD
1834	Seat Strap	3203	3/8" ID Flat Washer (Narrow)
1849	Seat Spacer	3204	1/4"-20 Hex Nut x/Nylok
1895	Clutch Anchor	3205	5/16"-18HexNutw/Nylok
1911	Roller Bracket Weldment	3206	3/8"-16HexNutw/Nylok
1917	Rear Roller Bracket Weldment	3207	1/2"-13HexNutw/Nylok
2128	Sleeve	3208	#10-24 Hex Nut w/Nylok
2928	3/16" X 1" Key	3224	5/16"-18 X 1" HH Bolt w/Nylok GR5
3002	5/16"-18X2 1/2"HHBGR8	3225	3/8"-16X2 1/4"HHBolt
3005	5/16"-18UNCHexNut	3227	5/16"-18X2"HHBoltGR5
3006	5/16"-18X 1/4" HH Bolt GR5	3231	9/16" Std Flat Washer
3007	1/4"-20 UNC Hex Nut	3235	#10-24 X 5/8" Phillips Pan HD Screw
3008	1/4" ID X 3/4" OD Flat Washer	3237	Eye Bolt 5/16" X 6.00"
3009	5/16"-18 UNC X 1 3/4" HH Bolt GR8	3243	5/16"-18X3 1/4"HHBoltGR5
3012	3/8"-16UNCHexNut	3245	3/8"-16 Thin Profile Nylok Nut
3014	1/4"-20 UNC X 3/4" HH Bolt GR5	3247	#6-20 X 1/2" Phillips Pan Hd Screw
3020	5/16" Std Flat Washer	3248	5/16" ID X 1/8" Thick Washer
3023	1/4" Helical Lock Washer	3249	5/8" Int Tooth Lock Washer
3033	1/2" SAE Flat Washer	3256	Snap Ring
3048	3/8"-16UNCX1 1/2" HH Bolt	3257	7/16" Int Tooth Lock Washer
3052	3/32" X 1" Cotter Pin	3260	1/4"-20X1/2"HHBoltGR5
3057	3/8" Std Flat Washer	3264	5/16" Disc Spring HD
3061	5/16"-18 UNC 1 3/4" Soc Set Screw	3265	#10-24 X 3/4" Truss Hd Phillips Screw
3066	3/16" Std Flat Washer	3266	1/4" Int Tooth Lock Washer
3068	1/8"X1" Cotter Pin	3267	5/16"-18X1 3/8" HH Bolt GR5
3072	1/8" X 1 3/4" Hair Pin Cotter	3268	3/8"-24 X 1 1/4" HHB GR8 w/Nylok
3074	5/16"-24UNFHexJamNut	3269	5/16"-18X1" Soc Hd Bolt
3087	5/16"-18 UNC X 3/4" HH Bolt GR5	3272	5/16" Int Tooth Lock Washer
3088	1/4"-20X1"HHBoltGR5	3273	8-18 X 3/8" Phillips Pan HD

## ZTR 560 PARTS LIST

3297	1/2"-13Thin Profile Nylok	3600	Rebound Mount
3298	Washer .51 5 X. 874 X. 031	3601	Load Mount
3300	Foam Pad	3602	Spacer Tube
3310	5/16"-18Thin Profile Nylok	3603	ISO Mount Insert
3318	3/8"-16X2 1/4"HHBoltGR8	3635	Tee - Fuel Line
3319	Idler Shock Mount	3644	Fuel Line 7 1/2"
3321	5/16"-18X8"HHBoltGR8	3646	Fuel Line 20"
3322	5/16"-18X51/2"HHBGR8	3649	Fuel Line Clamp
3325	3/8"-16X31/2"HHBGR8	3653	Floor Pad Left Front
3326	3/8"-16X4"HHBGR8	3654	Floor Pad Right Front
3331	M6XP1 X8MMHHBGR8.8	3655	Floor Pad Left Rear
3334	Nylok Nut	3656	Floor Pad Right Rear
3337	Retaining Ring	3669	Decal - Caution
3338	M8 X 1 .25 P HWH Tap Screw	3695	J-Bolt
3339	Snap Ring - 5/8"	3702	Pulley
3342	Washer .525 X 1 .375 X .25	3705	Velcro Strip - Hook
3343	Hub Bolt-Drilled	3706	Velcro Strip - Latch
3344	Grease Zerk	3717	3/8" Hose Clamp
3346	1/8" DiaX1 1/4" Cotter Pin	3718	5/8" Hose Clamp
3347	Washer 1. 033X1. 5 X. 06	3721	Decal Danger
3348	5/1 6"-1 8X3/4" Tap Screw	3746	Decal - Parking Brake
3349	#806 Woodruff Key	3772	By-Pass Keeper
3351	1/4"-20 X 1/2" HWH Tap Screw	3773	LH Rod End
3352	3/8"-16X1 1/4" HH Bolt GR5	3774	RH Rod End
3356	#12-1 4X3/4" Tap Screw	3805	Hand Grip - Black
3359	5/16"-18 X 3" HHB GR5 Alt Head	3812	Ignition Nut
3360	5/16"-18 X 4" HHB GR5 Alt Head	3813	Protective Cap
3361	Stud 1/2"-1 3X2"	3844	Decal - Hydro-Gear
3364	Washer - Bent	3852	Spring
3368	1/4"-20 X 3/4" HWH Tap Screw	3861	Control Panel 50"
3369	1/4"-20 U Nut	3876	Caster Spring
3370	1/4" Square Key X 2.50"	3878	Caster Plug
3373	6-32 X 1/2" HWH Slotted	3882	Hand Grip (Notched)
3374	6-32 Hex Nut w/Nylok	3887	Chrome Lug Nut
3375	L-Rod 3.5"	3889	Drive Pulley 1.13 Bore
3376	L-Rod 5"	3890	Bearing
3377	Serpentine Idler Spacer	3896	Hub Cover
3379	1/2"-13X3"HHBGR5	3898	Clutch Spacer
3380	7/16"-20X31/4"HHBGR5	3916	Decal - DIXON
3403	Bushing	3917	Bar Sleeve
3531	Decal - Operating Instructions	3919	Hour Meter
3536	Decal - Danger	3938	Deflector Spring
3558	2 Gallon Tank w/Cap	3947	Fuel Cap
3578	Nylon Bushing	3948	Flip-Lok Bushing
3585	Decal - Cutting Height	3952	Model Decal - 560

## **ZTR 560 PARTS LIST**

3955	Clutch Spacer	5554	Spacer 1/2" ODX 1/4"
4124	Solenoid w/Hardware	5558	Hose Fitting
4197	Ignition Switch	5559	Hose Fitting
4198	Blade Drive Clutch Switch	5560	Elbow - Male
4199	Light Switch	5561	Adapter - Male (For 3/8" ID Hose)
4217	Battery	5562	Adapter - Male (For 5/8" ID Hose)
4242	Deck Switch	5563	Tee - Cast Iron
4256	Utility Box	5564	Filter Head
4274	Choke Cable	5565	Oil Filter
4276	Headlight Assembly	5585	Tab
4384	Relay	5602	Hose Guard Spring
4453	Access Cover Assembly	5624	Tank Cap
4568	Throttle	5625	Gearbox
4584	Start Cable	5627	Left Fan
4585	Battery Ground Cable	5628	Right Fan
4589	Covered Key	5631	3/8" Hose -21"
4594	Wiring Cover 14"	5632	3/8" Hose - 5"
4598	Circuit Breaker	5633	5/8" Hose - 2"
4645	Wire Cover 30"	5635	Reservoir Assembly
4715	Seat Switch Assembly	5636	Brass Ferrule
4728	Upper Wiring Loom	5641	G-Box Mount Spacer
4757	Seat Assembly 50"	5643	Input Gear - GB
4773	Lower Wiring Loom	5644	Bearing - Gearbox
4774	Battery Cable Assembly	5645	Bearing Spacer - GB
5070	Key 3/1 6" Sq X . 88"	5661	5/8" X 12.5" ID Black Hose
5085	Brake Band	6075	Engaging Idler Bracket Spacer
5087	Spacer 3/8" X 1/2"	6100	Outer Shaft Key
5170	Spring	6101	Center Shaft Key
5189	Bushing	6168	Trash Guard
5257	Brake Drum (Keyed)	6260	Blade Washer
5283	Link	6291	Deck Roller
5500	T-Box	6293	Deflector Mount Bracket
5501	Mount Plate	6297	Deflector Pin
5502	Mount Shim	6367	Roller Shaft
5503	T-Box Guide Left	6744	Spring
5504	T-Box Guide Right	6938	V-Belt, Deck Drive
5515	Idler Cable	6939	Serpentine Belt
5522	Brake Link Right	7034	Belt Keeper
5525	Brake Link Left	8177	Caster Tire - 50"
5530	Control Pivot Shaft	8178	Caster Rim - 50"
5531	Adjustable Collar	8179	Caster Bearing - 50"
5537	Control Arm Bracket	8180	Bearing Retainer - 50"
5540	Neutral Adjust Collar	8294	Fuel Line 35 1/2"
5550	Hydrostat	8384	Upper Body
5551	Hydrostat	8385	Lower Body W/Decals

## ZTR 560 PARTS LIST

8387	Wiring Kit	9171	Spacer 1 .75
8404	Clutch Kit	9172	Spacer 1 .50
8429	Oil Valve/Hose Assembly	9174	Brake Rod
8432	Axle Housing Assembly	9175	Spring Anchor
8433	Hydro Mount Housing	9191	Connecting Link
8434	Splined Reduction Gear	9192	Tie Bar
8435	Final Drive Gear	9196	Plate
8436	Axle Assembly	9212	Spring (Belt Tensioner)
8437	Ball Bearing	9228	Deck Hub Bearing Spacer
8438	Brake Shaft	9280	Engine Plate
8439	E-Ring	9298	Caster Tube Assembly
8440	Ball 3/8" Diameter	9309	Caster Axle LH
8441	Bolt 1/2"-20X2 1/2"	9310	Caster Axle RH
8442	Washer .62 X 1 .0 X .05	9312	Bumper Weldment
8443	Spring Pin 3/16" X 1/2"	9315	Caster Wheel & Tire
8444	Type "O" Grease (Tube)	9325	Seat Frame Weldment
8452	42"/50" Battery Cover	9337	Shaft - Tapped (Short)
8467	Ball Bearing	9338	Shaft - Tapped (Long)
8468	Flanged Bearing	9372	Body Brace
8469	Brake Pin	9377	Brake Lever
8470	Lug Bolt	9381	Mower Deck Weldment
8471	Cap Plug 3/8"	9382	Mower Deck Assembly
8472	Cap Plug 1/4"	9383	Hi-Lift Blade
8484	Frame Weldment - 560	9385	Belt Guard LH
8572	Headlight Bulb	9386	Belt Guard RH
8573	Headlight Bulb Socket	9388	Deck Pulley 6.25
8576	Rear Rim	9615	Lift Shaft Weldment
8577	Rear Tire	9618	Lift Handle Weldment
8788	Tie Bar/Anchor Kit	9623	Lift Cam Drilled RH
8791	Convuluted Loom 1/2" X 60"	9624	Lift Cam Drilled LH
8799	60" Deflector w/Decal	9631	Hub Weldment Machined
9023	Engine Mount Plate - Forward	9633	Serpentine Idler Assembly
9031	Spacer	9634	Lift Frame Weldment
9049	Lift Bushing Bracket	9638	Deflector Hinge
9067	Control Rod	9640	Roller Bracket Weldment
9082	Seat Frame Pivot Rod	9646	Lift Plate
9098	L-Rod 9/16" X 153/16"	9651	Deflector Bracket
9110	Tank Cover	9652	Blow-by Baffle
9156	Right Swivel Plate		
9157	Left Swivel Plate		
9158	Control Lever w/Grip Left		
9159	Control Lever w/Grip Right		
9164	Brake Plate		
9165	Brake Plate		
9168	Brake Shaft Weldment		

# NOTES

---



# NOTES

---

---



DIXON INDUSTRIES, INC  
A BLOUNT COMPANY  
AIRPORT INDUSTRIAL PARK  
PO BOX 1569  
COFFEYVILLE KS 67337 0945  
316 251 2000  
FAX 316 251 4117

**BLOUNT**