

# LR120

**OWNER'S MANUAL**



## Safe Operation Practices for Ride-On Mowers



**IMPORTANT:** THIS CUTTING MACHINE IS CAPABLE OF AMPUTATING HANDS AND FEET AND THROWING OBJECTS. FAILURE TO OBSERVE THE FOLLOWING SAFETY INSTRUCTIONS COULD RESULT IN SERIOUS INJURY OR DEATH.

### I. GENERAL OPERATION

- Read, understand, and follow all instructions in the manual and on the machine before starting.
- Only allow responsible adults, who are familiar with the instructions, to operate the machine.
- Clear the area of objects such as rocks, toys, wire, etc., which could be picked up and thrown by the blade.
- Be sure the area is clear of other people before mowing. Stop machine if anyone enters the area.
- Never carry passengers.
- Do not mow in reverse unless absolutely necessary. Always look down and behind before and while backing.
- Be aware of the mower discharge direction and do not point it at anyone. Do not operate the mower without either the entire grass catcher or the guard in place.
- Slow down before turning.
- Never leave a running machine unattended. Always turn off blades, set parking brake, stop engine, and remove keys before dismounting.
- Turn off blades when not mowing.
- Stop engine before removing grass catcher or unclogging chute.
- Mow only in daylight or good artificial light.
- Do not operate the machine while under the influence of alcohol or drugs.
- Watch for traffic when operating near or crossing roadways.
- Use extra care when loading or unloading the machine into a trailer or truck.

### II. SLOPE OPERATION

Slopes are a major factor related to loss-of-control and tipover accidents, which can result in severe injury or death. All slopes require extra caution. If you cannot back up the slope or if you feel uneasy on it, do not mow it.

#### DO:

- Mow up and down slopes, not across.
- Remove obstacles such as rocks, tree limbs, etc.
- Watch for holes, ruts, or bumps. Uneven terrain could overturn the machine. *Tall grass can hide obstacles.*
- Use slow speed. Choose a low gear so that you will not have to stop or shift while on the slope.
- Follow the manufacturer's recommendations for wheel weights or counterweights to improve stability.
- Use extra care with grass catchers or other attachments. These can change the stability of the machine.
- Keep all movement on the slopes *slow* and *gradual*. Do not make sudden changes in speed or direction.
- Avoid starting or stopping on a slope. If tires lose traction, disengage the blades and proceed slowly *straight* down the slope.

#### DO NOT:

- *Do not* turn on slopes unless necessary, and then, turn slowly and gradually downhill, if possible.
- *Do not* mow near drop-offs, ditches, or embankments. The mower could suddenly turn over if a wheel is over the edge of a cliff or ditch, or if an edge caves in.
- *Do not* mow on wet grass. Reduced traction could cause sliding.
- *Do not* try to stabilize the machine by putting your foot on the ground.
- *Do not* use grass catcher on steep slopes.

### III. CHILDREN

Tragic accidents can occur if the operator is not alert to the presence of children. Children are often attracted to the machine and the mowing activity. *Never* assume that children will remain where you last saw them.

- Keep children out of the mowing area and under the watchful care of another responsible adult.
- Be alert and turn machine off if children enter the area.
- Before and when backing, look behind and *down* for small children.
- Never carry children. They may fall off and be seriously injured or interfere with safe machine operation.
- Never allow children to operate the machine.
- Use extra care when approaching blind corners, shrubs, trees, or other objects that may obscure vision.

### IV. SERVICE

- Use extra care in handling gasoline and other fuels. They are flammable and vapors are explosive.
  - Use only an approved container.
  - Never remove gas cap or add fuel with the engine running. Allow engine to cool before refueling. Do not smoke.
  - Never refuel the machine indoors.
  - Never store the machine or fuel container inside where there is an open flame, such as a water heater.
- Never run a machine inside a closed area.
- Keep nuts and bolts, especially blade attachment bolts, tight and keep equipment in good condition.
- Never tamper with safety devices. Check their proper operation regularly.
- Keep machine free of grass, leaves, or other debris build-up. Clean oil or fuel spillage. Allow machine to cool before storing.
- Stop and inspect the equipment if you strike an object. Repair, if necessary, before restarting.
- Never make adjustments or repairs with the engine running.
- Grass catcher components are subject to wear, damage, and deterioration, which could expose moving parts or allow objects to be thrown. Frequently check components and replace with manufacturer's recommended parts, when necessary.
- Mower blades are sharp and can cut. Wrap the blade(s) or wear gloves, and use extra caution when servicing them.
- Check brake operation frequently. Adjust and service as required.



Look for this symbol to point out important safety precautions. It means **CAUTION!!! BECOME ALERT!!! YOUR SAFETY IS INVOLVED.**



**CAUTION:** Always disconnect spark plug wire and place wire where it cannot contact spark plug in order to prevent accidental starting when setting up, transporting, adjusting or making repairs.

**CONGRATULATIONS** on your purchase of a new Tractor. It has been designed, engineered and manufactured to give you the best possible dependability and performance.

Should you experience any problem you cannot easily remedy, please contact your nearest authorized service facility. We have competent, well-trained technicians and the proper tools to service or repair this unit.

Please read and retain this manual. The instructions will enable you to assemble and maintain your unit properly. Always observe the "SAFETY RULES".

## INTERNATIONAL SYMBOLS

These symbols may appear on your unit or in the literature supplied with the product. Learn and understand their meaning.

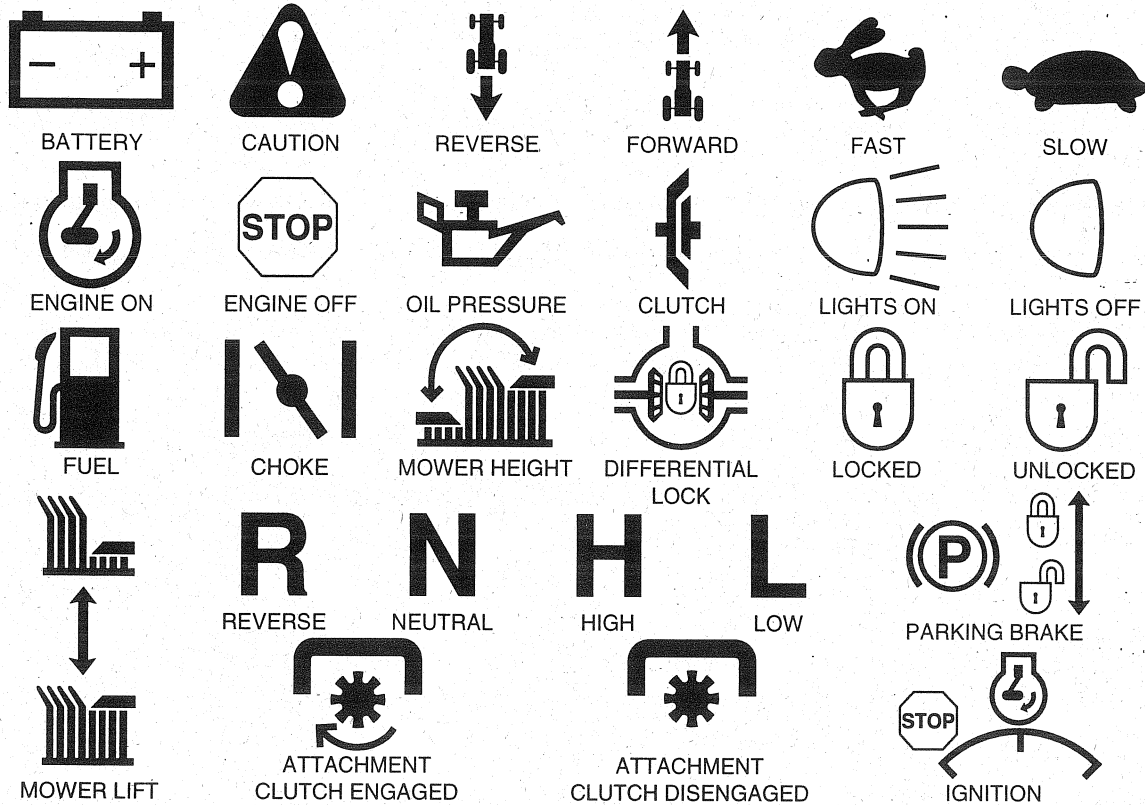

**NOTE:** The illustrations shown in this manual are to aid in the assembly and operation of your tractor. They may or may not show the actual model you have purchased.

**WARNING:** This unit is equipped with an internal combustion engine and should not be used on or near any unimproved forest-covered, brush-covered or grass-covered land unless the engine's exhaust system is equipped with a spark arrester meeting applicable local or state laws (if any). If a spark arrester is used, it should be maintained in effective working order by the operator.

In the state of California the above is required by law (Section 4442 of the California Public Resources Code). Other states may have similar laws. Federal laws apply on federal lands. A spark arrester for the muffler is available through your nearest authorized service facility.

## TABLE OF CONTENTS

SAFETY RULES .....	2	STORAGE .....	20
ASSEMBLY .....	5-8	SCHEMATIC .....	21
OPERATION .....	9-12	REPAIR PARTS .....	22-40
CUSTOMER RESPONSIBILITIES .....	13-15	TROUBLE SHOOTING .....	42-43
SERVICE AND ADJUSTMENTS .....	16-19	WARRANTY .....	46, 47

# CONTENTS OF HARDWARE PACK

## Parts Bag contents shown full size

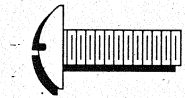

(2) Screws #10 x 5/8



(2) Lock Washers #10

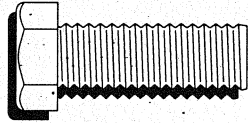

(2) Hex Bolts 5/16-18 x 1



(2) Locknuts 5/16-18

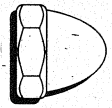

(2) Acorn Nuts 5/16-18

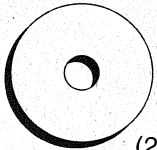

(2) Washers 3/16 x 3/4 x 16 Gauge

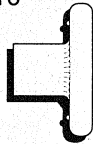

(2) Weld Nuts #10

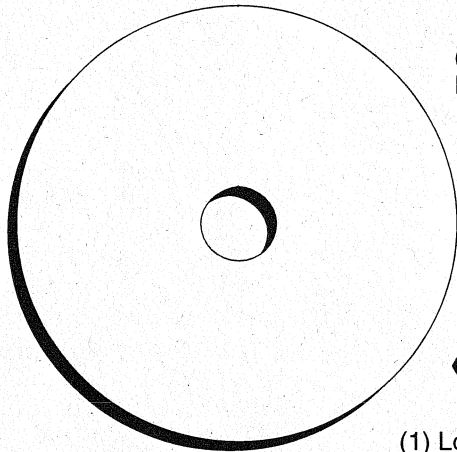

(1) Large Flat Washer



(1) Locknut 3/8-24

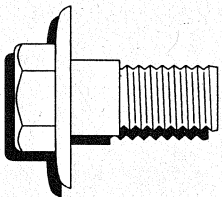

(1) Shoulder Bolt 5/16-18

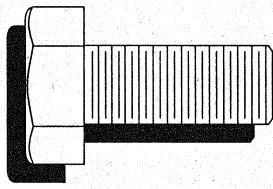

(1) Hex Bolt 1/2-13 x 1

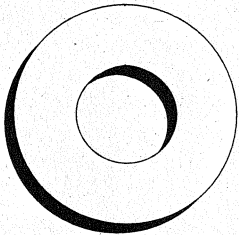

(1) Washer 17/32 x 1-3/16 x 12 Gauge

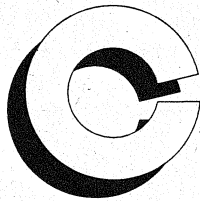

(1) Lock Washer 1/2



(2) Hex Bolts 1/4-20 x 3/4



(2) Hex Nuts 1/4-20



(2) Washers 9/32 x 5/8 x 16 Ga.



(2) Lock Washers 1/4

## Parts packed separately in carton

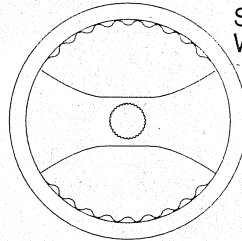

Steering Wheel

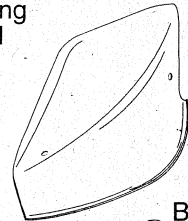

Mulcher Plate

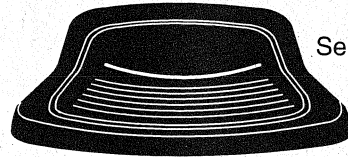

Seat

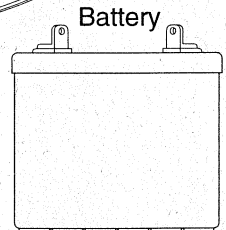

Battery

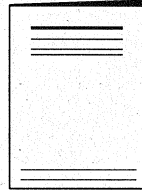

Owner's Manual



Steering Sleeve

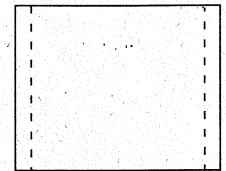

Parts Bag

## Parts bag contents not shown full size

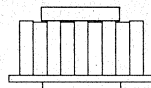

Steering Wheel Adapter

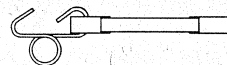

(2) Latch Hook Assemblies

Steering Wheel Insert

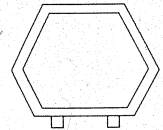

Steering Clip



(2) Keys

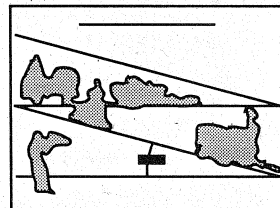

15° Slope Sheet

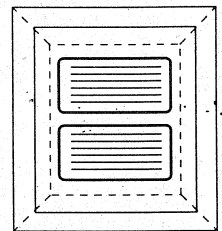

Battery Caps and Instructions

# ASSEMBLY

## TOOLS REQUIRED FOR ASSEMBLY

A socket wrench set will make assembly easier. Standard wrench sizes are listed.

- |                    |                     |
|--------------------|---------------------|
| (1) 9/16" wrench   | Pliers              |
| (2) 7/16" wrenches | Tire pressure gauge |
| (2) 1/2" wrenches  | Screwdriver         |
| (1) 3/4" wrench    | Utility knife       |

When right and left hand are mentioned in this manual, it means when you are in the operating position (seated behind the steering wheel).

## TO REMOVE UNIT FROM CARTON

### UNPACK CARTON

- Remove all accessible loose parts and parts cartons from carton (See page 4).
- Cut from top to bottom, all four corners of carton and lay panels flat.
- Check for any additional loose parts or cartons and remove.

## BEFORE ROLLING UNIT OFF SKID

### ATTACH STEERING WHEEL

POSITION STEERING SHAFT (See Fig. 1) -

- Lift hood.
- Pull steering shaft up to engage gears.
- Push steering clip through hole on steering shaft at 45° (hole is located under dash and above lower steering bushing).
- Push steering clip onto steering shaft until steering clip snaps into place.

INSTALL STEERING WHEEL (See Fig. 2) -

- Slide the steering sleeve over the steering shaft (Bottom of sleeve goes over ring on dash).
- Slide steering wheel adapter onto upper steering shaft.
- Position front wheels of the tractor so they are pointing straight forward.
- Position steering wheel so cross bars are horizontal (left to right) and slide onto adapter.
- Assemble large flat washer and 3/8-24 locknut and tighten securely.
- Snap insert into center of steering wheel.
- Remove protective plastic from tractor hood and grill.

**IMPORTANT:** CHECK FOR AND REMOVE ANY STAPLES IN SKID THAT MAY PUNCTURE TIRES WHERE UNIT IS TO ROLL OFF SKID.

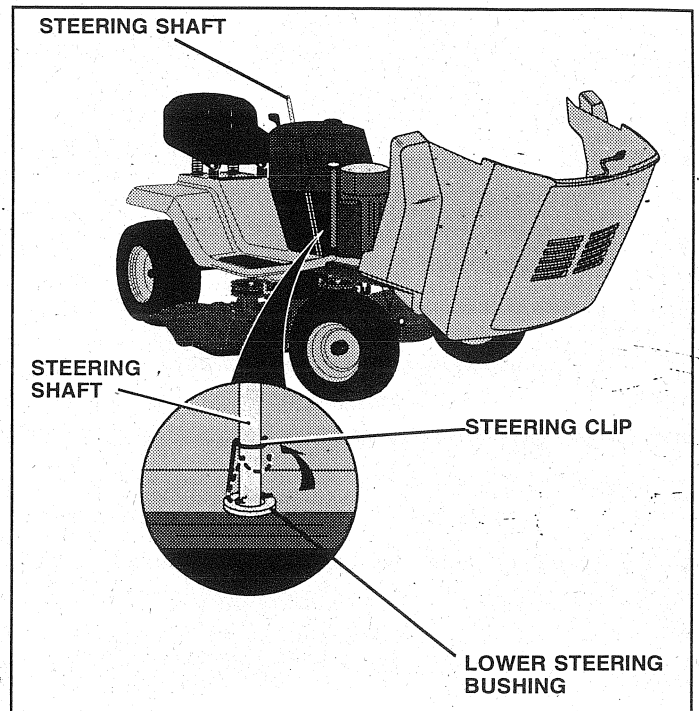

FIG. 1

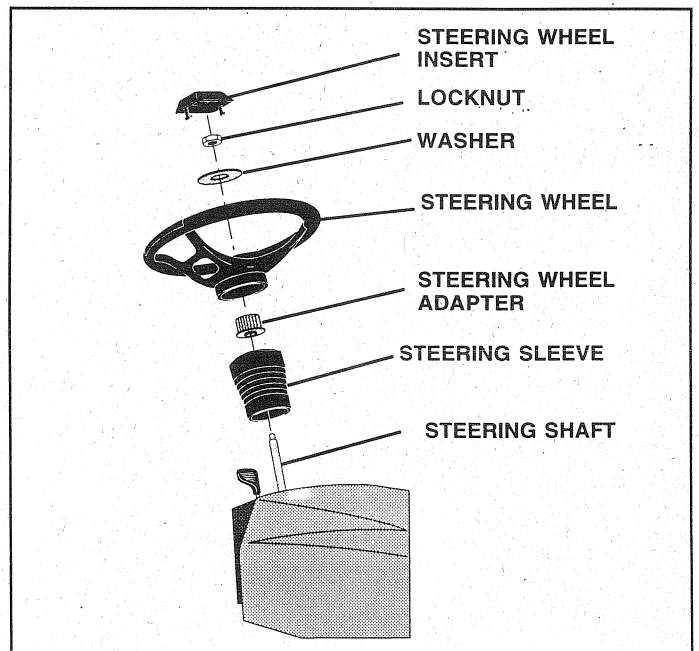

FIG. 2

## TO ROLL UNIT OFF SKID (See Fig. 7)

- Raise mower lift lever to its highest position.
- Release parking brake by depressing clutch/brake pedal.
- Place gearshift lever in "NEUTRAL" position.
- Roll unit backwards off skid.
- Remove banding holding discharge guard up against tractor.

# ASSEMBLY

## HOW TO SET UP YOUR TRACTOR

### PREPARE BATTERY (See Fig. 3)



**CAUTION: Wear eye and face shield. Wash hands or clothing immediately if accidentally in contact with battery acid. Do not smoke. Fumes from charged battery acid are explosive. Read the instructions included with the battery vent caps. Always wear gloves, clothing and goggles to protect your hands, skin and eyes.**

Your unit has a battery charging system which is sufficient for normal use. However, periodic charging of the battery with an automotive charger will extend its life.

- See instructions packed with vent caps in parts bag.
- Fill battery with acid. Fill each cell until it reaches the bottom of the vent wells. Do not overfill.
- Allow battery to stand and settle for at least thirty minutes. After standing, check the level of acid. If below the vent wells, add more acid until the correct level is reached.

While battery is standing (after adding acid) and later, while battery is being charged, continue with assembly of unit.

**IMPORTANT: TO MAXIMIZE THE LIFE OF YOUR BATTERY, IT IS NECESSARY THAT THE BATTERY BE CHARGED BEFORE USE. FAILURE TO CHARGE BATTERY CAN RESULT IN A SHORTENED BATTERY LIFE.**

- Charge battery at a rate of 6 amperes for 1 hour. Use a 12 volt battery charger. Observe all safety precautions required for battery charging.
- Check the acid level after the battery is charged. If the acid has fallen below the correct level, add distilled or iron free water.
- Install the vent caps to cover the vent wells. Wash the top of the battery with water to remove any acid, then wipe dry.
- Check battery case for leakage to make sure that no damage has occurred in handling.
- Dispose of excess battery acid. Neutralize acid for disposal by adding it to four inches of water in a five gallon plastic container. Stir with a wooden or plastic paddle while adding baking soda until the addition of more soda causes no more foaming.
- Follow instructions on how to install battery.

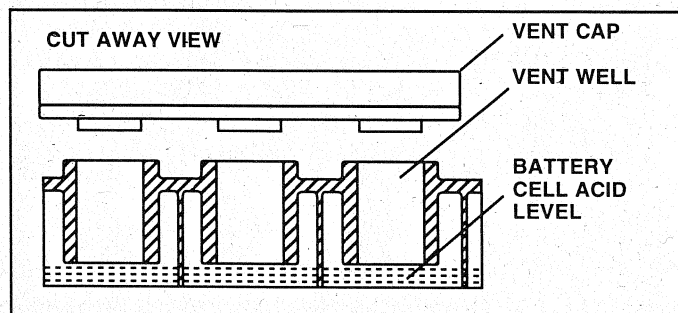

FIG. 3

### INSTALL SEAT (See Fig. 4)

Adjust seat before tightening adjustment bolt.

- Remove cardboard packing on seat pan.
- Place seat on pan and assemble shoulder bolt.
- Assemble adjustment bolt, lock washer and flat washer loosely. Do not tighten.
- Tighten shoulder bolt securely.
- Lower seat into operating position and sit on seat.
- Slide seat until a comfortable position is reached which allows you to press clutch/brake pedal all the way down (See Fig. 7).
- Get off seat without moving its adjusted position.
- Raise seat and tighten adjustment bolt securely.

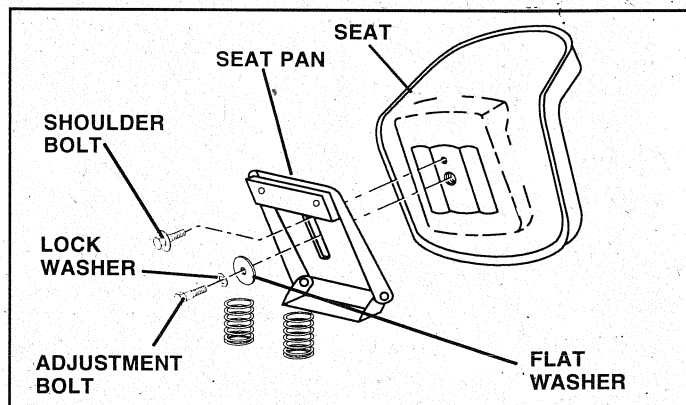

FIG. 4

### PREPARE MOWER DECK FOR MULCHER PLATE (See Fig. 5A)

- Using holes provided in mower deck, install 5/16-18x1 hex bolts, 5/16-18 locknuts, and 5/16-18 acorn nuts.
- Install hex bolt from under mower deck and tighten locknut securely. Assemble and tighten acorn nut on hex bolt.

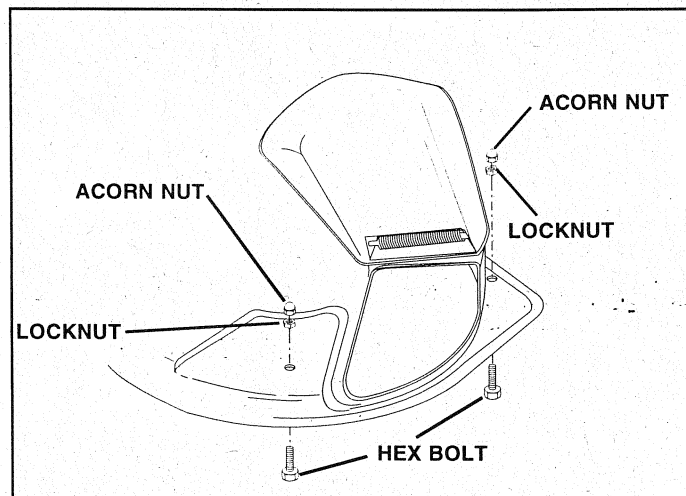

FIG. 5A

# ASSEMBLY

## INSTALL MULCHER PLATE (See Figs. 5B and 5C)

- Install two latch hooks to mulcher plate using screw, washer, lock washer, and weld nut as shown.

**NOTE:** Pre-assemble weld nut to latch hook by inserting weld nut from the top with hook pointing down:

- Tighten hardware securely.
- Raise and hold deflector shield in upright position.
- Place front of mulcher plate over front of mower deck opening and slide into place, as shown.
- Hook front latch hook onto hex bolt on front of mower deck.
- Hook rear latch hook onto hex bolt on back of mower deck.



**CAUTION:** Do not remove discharge guard from mower. Raise and hold guard when attaching mulcher plate and allow it to rest on plate while in operation.

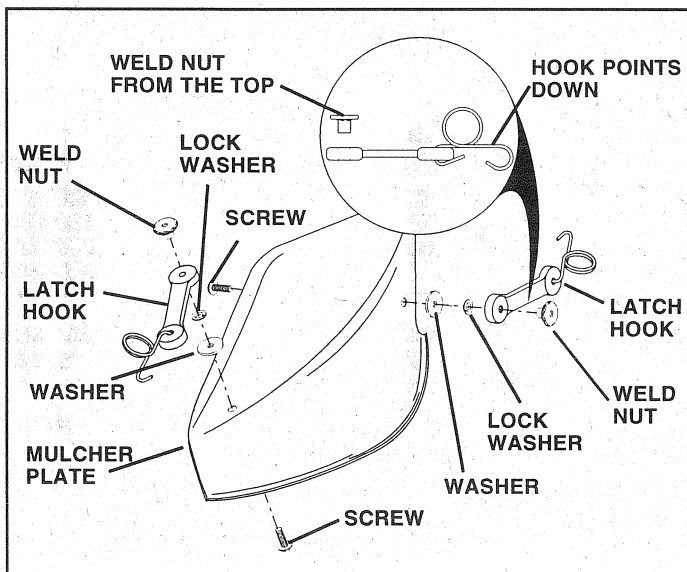

FIG. 5B

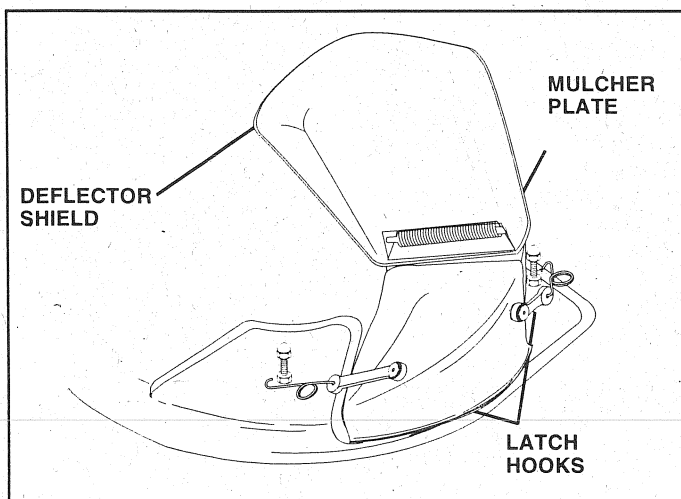

FIG. 5C

## TO CONVERT TO BAGGING OR DISCHARGING

Simply remove mulcher plate and store in a safe place. Your mower is now ready for discharging or installation of optional grass catcher accessory.

**NOTE:** It is not necessary to change blades. The mulcher blades are designed for discharging and bagging also.

## CHECK TIRE PRESSURE

The tires on your unit were overinflated at the factory for shipping purposes. Correct tire pressure is important for best cutting performance.

- Reduce tire pressure to 14 PSI in front tires and 12 PSI in rear tires.

## CHECK DECK LEVELNESS

For best cutting results, mower housing should be properly leveled. See "TO LEVEL MOWER HOUSING" in the Service and Adjustments section of this manual.

## CHECK FOR PROPER POSITION OF ALL BELTS

See the figures that are shown for replacing motion and mower blade drive belts in the Service and Adjustments section of this manual. Verify that the belts are routed correctly.

## CHECK BRAKE SYSTEM

After you learn how to operate your tractor, check to see that the brake is properly adjusted. See "TO ADJUST BRAKE" in the Service and Adjustments section of this manual.

# ASSEMBLY

## INSTALL BATTERY (See Figs. 6A and 6B)



**CAUTION:** Do not short battery terminals. Before installing battery, remove metal bracelets, wristwatch bands, rings, etc.

Positive terminal must be connected first to prevent sparking from accidental grounding.

- Lift seat to raised position.
- Open battery box door.
- Be sure drain tube is attached to bottom of battery box and tube passes through hole in chassis for proper drainage.
- Lower battery into battery box with battery terminals toward front of tractor.
- First connect RED battery cable and RED fused ignition wire to positive (+) battery terminal with hex bolt, flat washer, lock washer and hex nut as shown. Tighten securely.
- Connect BLACK grounding cable to negative (-) battery terminal with remaining hex bolt, flat washer, lock washer and hex nut. Tighten securely.
- Close battery box door.

Open battery box door for:

- Inspection for secure connections (to tighten hardware).
- Inspection for corrosion.
- Testing battery.
- Jumping (if required).
- Periodic charging.

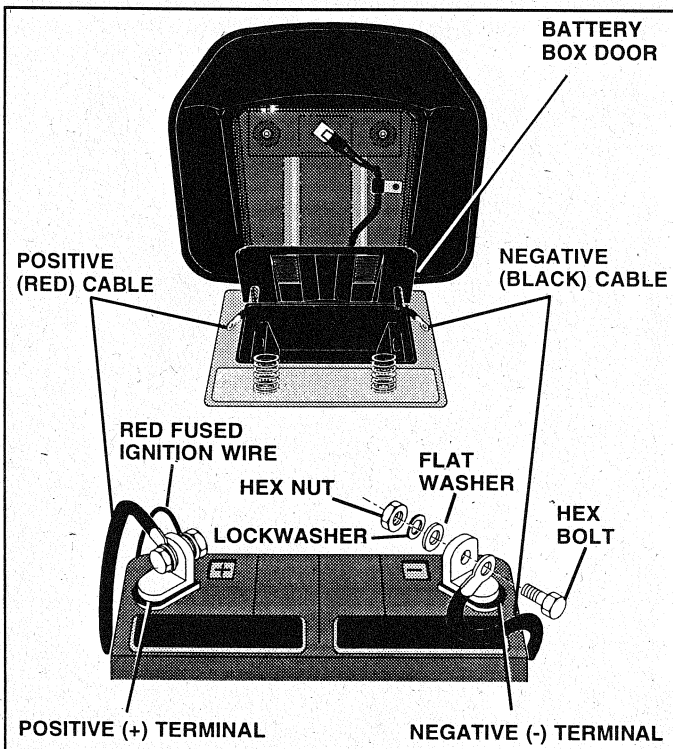

FIG. 6A

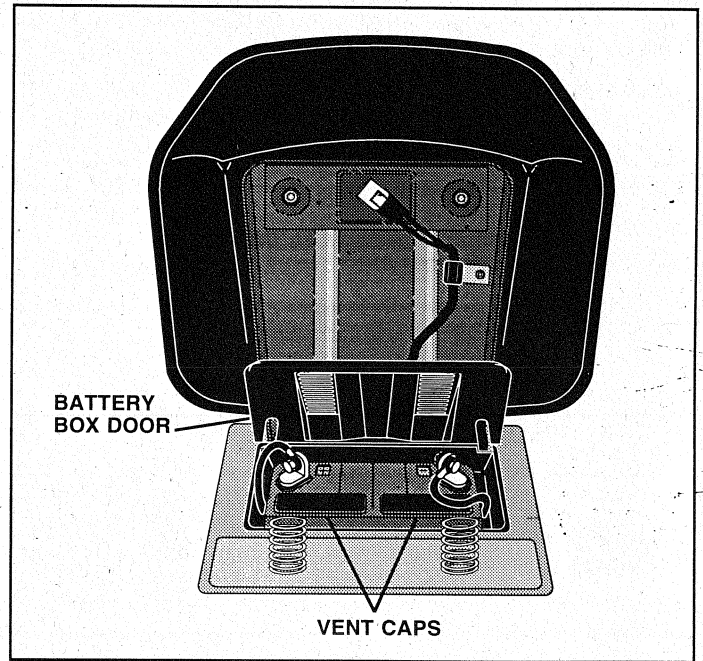

FIG. 6B

## ✓ CHECKLIST

*BEFORE YOU OPERATE AND ENJOY YOUR NEW TRACTOR, WE WISH TO ASSURE THAT YOU RECEIVE THE BEST PERFORMANCE AND SATISFACTION FROM THIS QUALITY PRODUCT.*

*PLEASE REVIEW THE FOLLOWING CHECKLIST:*

- ✓ All assembly instructions have been completed.
- ✓ No remaining loose parts in carton.
- ✓ Battery is properly prepared and charged. (Minimum 1 hour at 6 amps).
- ✓ Seat is adjusted comfortably and tightened securely.
- ✓ All tires are properly inflated. (For shipping purposes, the tires were overinflated at the factory).
- ✓ Be sure mower deck is properly leveled side-to-side/front-to-rear for best cutting results. (Tires must be properly inflated for leveling).
- ✓ Check mower and drive belts. Be sure they are routed properly around pulleys and inside all belt keepers.
- ✓ Check wiring. See that all connections are still secure and wires are properly clamped.

*WHILE LEARNING HOW TO USE YOUR TRACTOR, PAY EXTRA ATTENTION TO THE FOLLOWING IMPORTANT ITEMS:*

- ✓ Engine oil is at proper level.
- ✓ Fuel tank is filled with fresh, clean, regular unleaded gasoline.
- ✓ Become familiar with all controls - their location and function. Operate them before you start the engine.
- ✓ Be sure brake system is in safe operating condition.



# OPERATION

## KNOW YOUR TRACTOR

### READ THIS OWNER'S MANUAL AND SAFETY RULES BEFORE OPERATING YOUR TRACTOR.

Compare the illustrations with your Tractor to familiarize yourself with the location of various controls and adjustments. Save this manual for future reference.

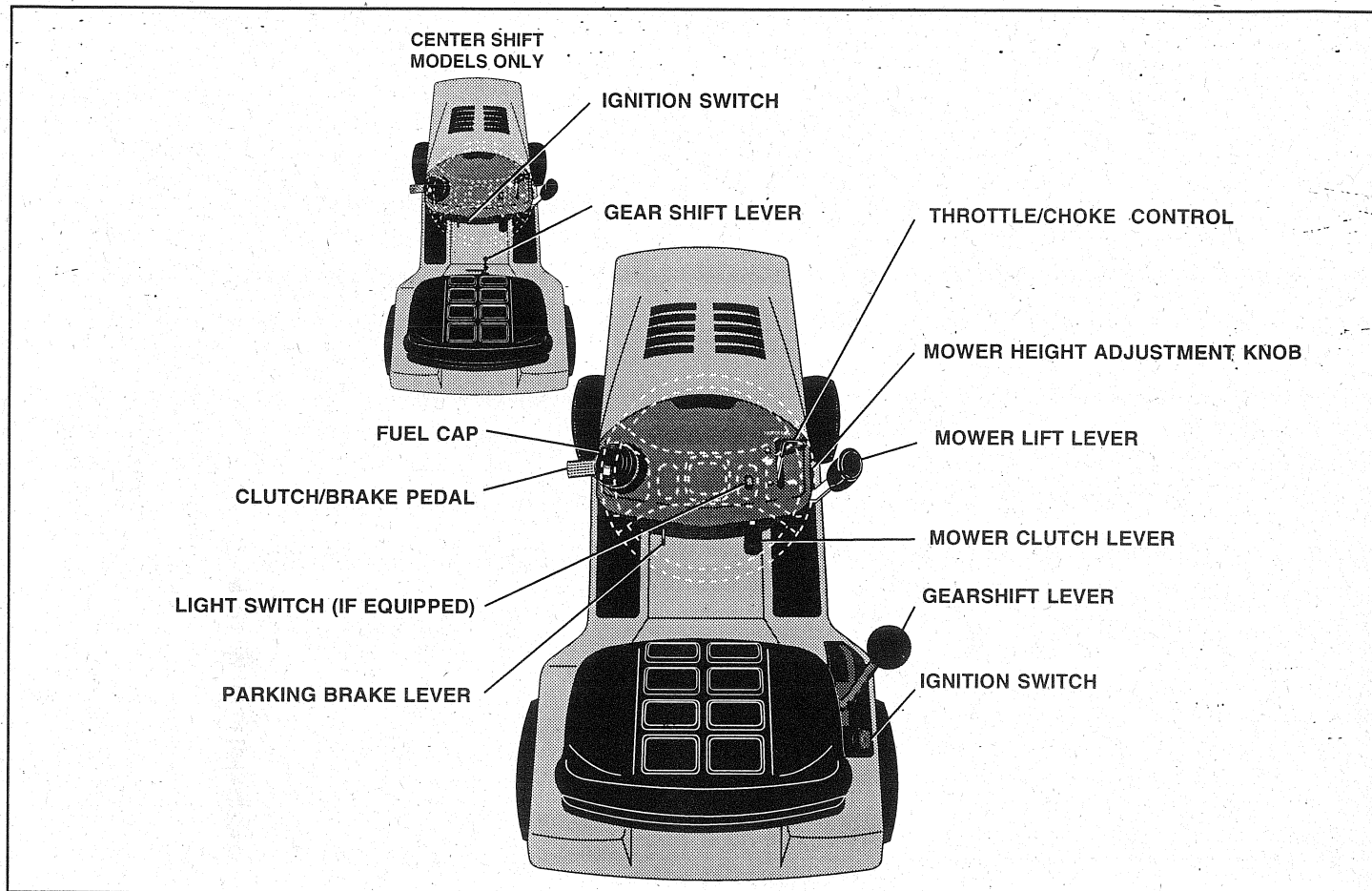

FIG. 7

Your tractor conforms to the safety standards of the American National Standards Institute.

**IGNITION SWITCH:** Used for starting and stopping the engine.

**THROTTLE/CHOKE CONTROL:** Used for starting and controlling engine speed.

**CLUTCH/BRAKE PEDAL:** Used for declutching and braking the lawn rider and starting the engine.

**GEARSHIFT LEVER:** Selects the speed and direction of the lawn rider.

**LIGHT SWITCH:** (If so equipped) Turns headlights on or off.

**PARKING BRAKE LEVER:** Locks clutch/brake pedal into the brake position.

**MOWER CLUTCH LEVER:** Used to engage the mower blades.

**MOWER LIFT LEVER:** Used to raise and lower the mower deck.

**MOWER HEIGHT ADJUSTMENT KNOB:** Used to set mower cutting height.

# OPERATION



The operation of any tractor can result in foreign objects thrown into the eyes, which can result in severe eye damage. Always wear safety glasses or eye shields before starting your tractor and while moving. We recommend wide vision safety mask for over the spectacles or standard safety glasses.

## HOW TO USE YOUR TRACTOR

### TO SET PARKING BRAKE (See Fig. 8)

- Depress clutch/brake pedal into full "BRAKE" position and hold.
- Place parking brake lever in "ENGAGED" position and release pressure from clutch/brake pedal. Pedal should remain in "BRAKE" position. Make sure parking brake will hold vehicle secure.

### STOPPING (See Figs. 8 and 9)

#### MOWER BLADES -

- Move mower clutch lever to "DISENGAGED" position.

#### GROUND DRIVE -

- Depress clutch/brake pedal into full "BRAKE" position.
- Move gearshift lever to "NEUTRAL" position.

#### ENGINE -

- Move throttle control to "SLOW" position.

**NOTE:** Failure to move throttle control to "SLOW" position and allowing engine to idle before stopping may cause engine to "backfire".

- Turn ignition key to "OFF" position and remove key. Always remove key when leaving vehicle to prevent unauthorized use.
- Never use choke to stop engine.

**NOTE:** Under certain conditions when unit is standing idle with the engine running, hot engine exhaust gases may cause "browning" of grass. To eliminate this possibility, always stop engine when stopping unit on grass areas.



**CAUTION:** Always stop unit completely, as described above, before leaving the operators position; to empty grass catcher; etc.

### TO USE THROTTLE CONTROL (See Fig. 9)

Always operate engine at full throttle.

- Operating engine at less than full throttle reduces the battery charging rate.
- Full throttle offers the best bagging and mower performance.

### TO MOVE FORWARD AND BACKWARD (See Figs. 8 and 9)

The direction and speed of movement is controlled by the gearshift lever.

- Start tractor with clutch/brake pedal depressed and gearshift lever in "NEUTRAL" position.
- Move gearshift lever to desired position.
- Slowly release clutch/brake pedal to start movement.

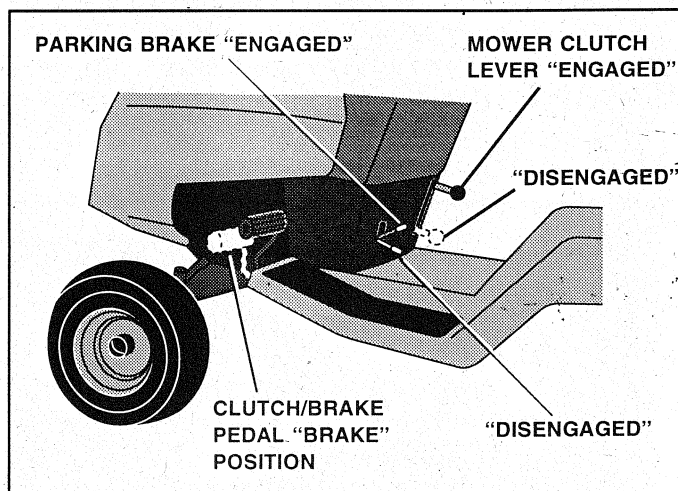

FIG. 8

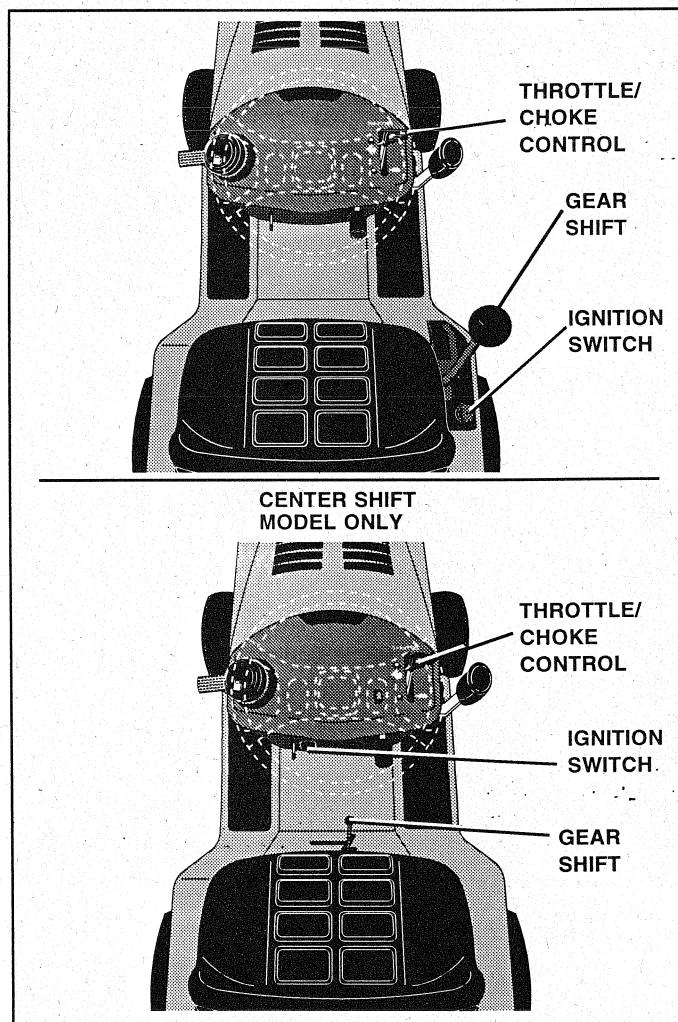

FIG. 9

# OPERATION

## TO ADJUST MOWER CUTTING HEIGHT (See Fig. 10)

The position of the mower lift lever determines the cutting height. The position of the mower lift lever can be adjusted by moving the height adjustment knob to desired position.

- With lift lever back and locked in highest position, pull out the adjustment knob and move to desired position.
- Move mower lift lever out and forward to adjustment knob.

The cutting height range is approximately 1" to 3-1/2". The heights are measured from the ground to the blade tip with the engine not running. These heights are approximate and may vary depending upon soil conditions, height of grass and types of grass being mowed.

- The average lawn should be cut to approximately 2-1/2 inches during the cool season and to over 3 inches during hot months. For healthier and better looking lawns, mow often and after moderate growth.
- For best cutting performance, grass over 6 inches in height should be mowed twice. Make the first cut relatively high; the second to desired height.

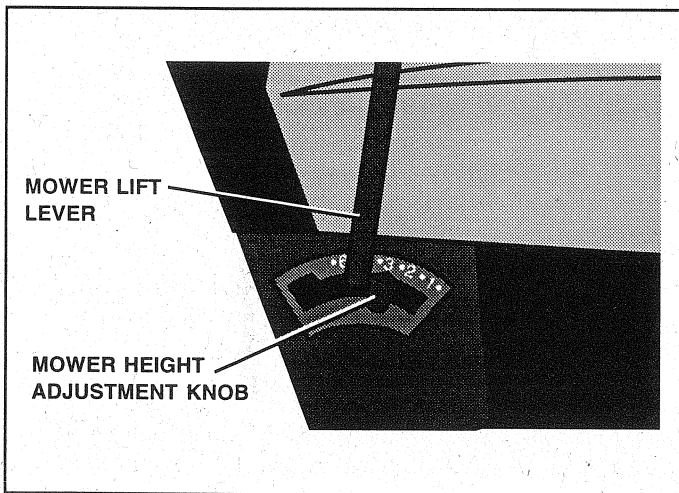

FIG. 10

## TO OPERATE MOWER (See Figs. 10 and 11)

Your unit is equipped with an operator presence sensing switch. Any attempt by the operator to leave the seat with the engine running and the mower clutch engaged will shut off the engine.

- Select desired height of cut.
- Engage mower by slowly moving mower clutch lever to "ENGAGED" position.
- TO STOP MOWER - Move mower clutch lever to "DISENGAGED" position.

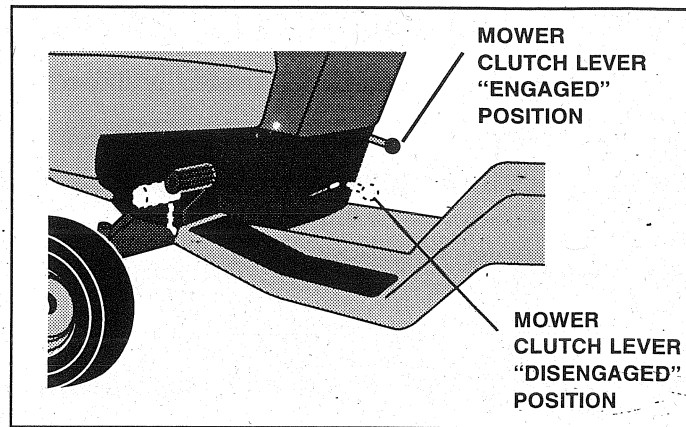

FIG. 11

## TO OPERATE ON HILLS



**CAUTION:** Do not drive up or down hills with slopes greater than 15° and do not drive across any slope.

- Choose the slowest speed before starting up or down hills.
- Avoid stopping or changing speed on hills.
- If slowing is necessary, move throttle control lever to slower position.
- If stopping is absolutely necessary, push clutch/brake pedal quickly to brake position and engage parking brake.
- Move gearshift lever to 1st gear and be sure you have allowed room for tractor to roll slightly as you restart movement.
- To restart movement, slowly release parking brake and clutch/brake pedal.
- Make all turns slowly.

**NOTE:** To protect hood from damage when transporting your tractor on a truck or a trailer, be sure hood is closed and secured to tractor. Use an appropriate means of tying hood to tractor (rope, cord, etc.).

## TO TRANSPORT

- Raise mower lift lever to highest position.
- When pushing or towing your unit, be sure gearshift lever is in "NEUTRAL" position.
- Do not push unit at more than five (5) MPH.

## BEFORE STARTING THE ENGINE

### CHECK ENGINE OIL LEVEL

- The engine in your unit has been shipped, from the factory, already filled with summer weight oil.
- Check engine oil with unit on level ground.
- Remove oil fill dipstick and wipe clean, replace and screw cap tight, wait for a few seconds, remove and read oil level. If necessary, add oil until "FULL" mark on dipstick is reached. Do not overfill.
- For cold weather operation you should change oil for easier starting (Refer to Engine Manual).
- To change engine oil, see the Customer Responsibility section in this manual.



**CAUTION:** Do not operate the mower without either the entire grass catcher, on mowers so equipped, or the discharge guard in place.

# OPERATION

## ADD GASOLINE

- Fill fuel tank. Use fresh, clean, regular unleaded gasoline. (Use of leaded gasoline will increase carbon and lead oxide deposits and reduce valve life).

**IMPORTANT:** WHEN OPERATING IN TEMPERATURES BELOW 32°F(0°C), USE FRESH, CLEAN WINTER GRADE GASOLINE TO HELP INSURE GOOD COLD WEATHER STARTING.

**WARNING:** Experience indicates that alcohol blended fuels (called gasohol or using ethanol or methanol) can attract moisture which leads to separation and formation of acids during storage. Acidic gas can damage the fuel system of an engine while in storage. To avoid engine problems, the fuel system should be emptied before storage of 30 days or longer. Drain the gas tank, start the engine and let it run until the fuel lines and carburetor are empty. Use fresh fuel next season. See Storage Instructions for additional information. Never use engine or carburetor cleaner products in the fuel tank or permanent damage may occur.



**CAUTION:** Fill to bottom of gas tank filler neck. Do not overfill. Wipe off any spilled oil or fuel. Do not store, spill or use gasoline near an open flame.

## TO START ENGINE (See Fig. 7)

When starting engine for the first time or if engine has run out of fuel, it will take extra cranking time to move fuel from the tank to the engine.

- Depress the clutch/brake pedal and set the parking brake.
- Place gearshift lever in "NEUTRAL" position.
- Move mower clutch to "DISENGAGED" position.
- Move throttle control lever to "CHOKE" position for cold engine start. For warm engine start, move throttle control to "FAST" position.
- Insert key into ignition and turn key clockwise to "START" position and release key as soon as engine starts. Do not run starter continuously for more than fifteen seconds per minute. If engine does not start after several attempts, move throttle control to "FAST" position, wait a few minutes and try again.
- When engine starts, move throttle control to desired position.
- Allow engine to warm up for a few minutes before engaging drive or attachment clutch.

**NOTE:** If at a high altitude (above 3000 feet) or in cold temperatures (below 32° F), the carburetor fuel mixture may need to be adjusted for best engine performance. See "TO ADJUST CARBURETOR" in the Service and Adjustments section of this manual.

## MOWING TIPS

- Mower should be properly leveled for best mowing performance. See "TO LEVEL MOWER HOUSING" in the Service and Adjustments section of this manual.
- The left hand side of mower should be used for trimming.
- Drive so that clippings are discharged onto the area that has been cut. Have the cut area to the right of the machine. This will result in a more even distribution of clippings and more uniform cutting.
- When mowing large areas, start by turning to the right so that clippings will discharge away from shrubs, fences, driveways, etc. After one or two rounds, mow in the

opposite direction making left hand turns until finished (See Fig. 12).

- If grass is extremely tall, it should be mowed twice to reduce load and possible fire hazard from dried clippings. Make first cut relatively high; the second to the desired height.
- Do not mow grass when it is wet. Wet grass will plug mower and leave undesirable clumps. Allow grass to dry before mowing.
- Always operate engine at full throttle when mowing to assure better mowing performance and proper discharge of material. Regulate ground speed by selecting a low enough gear to give the mower cutting performance as well as the quality of cut desired.
- When operating attachments, select a ground speed that will suit the terrain and give best performance of the attachment being used.

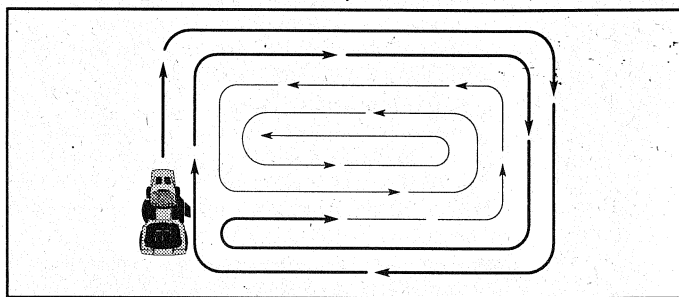

FIG. 12

## MULCHING MOWING TIPS

**IMPORTANT:** FOR BEST PERFORMANCE, KEEP MOWER HOUSING FREE OF BUILT-UP GRASS AND TRASH. CLEAN AFTER EACH USE.

- The special mulching blade will recut the grass clippings many times and reduce them in size so that as they fall onto the lawn they will disperse into the grass and not be noticed. Also, the mulched grass will biodegrade quickly to provide nutrients for the lawn. Always mulch with your highest engine (blade) speed as this will provide the best recutting action of the blades.
- Avoid cutting your lawn when it is wet. Wet grass tends to form clumps and interferes with the mulching action. The best time to mow your lawn is the early afternoon. At this time the grass has dried and the newly cut area will not be exposed to the direct sun.
- For best results, adjust the mower cutting height so that the mower cuts off only the top one-third of the grass blades (See Fig. 13). For extremely heavy mulching, reduce your width of cut on each pass and mow slowly.
- Certain types of grass and grass conditions may require that an area be mulched a second time to completely hide the clippings. When doing a second cut, mow across or perpendicular to the first cut path.
- Change your cutting pattern from week to week. Mow north to south one week then change to east to west the next week. This will help prevent matting and graining of the lawn.

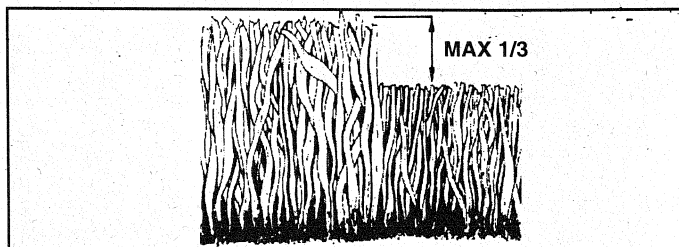

FIG. 13

# CUSTOMER RESPONSIBILITIES

MAINTENANCE SCHEDULE							SERVICE DATES							
		BEFORE EACH USE	FIRST 2 HOURS	EVERY 8 HOURS	EVERY 25 HOURS	EVERY 50 HOURS	EVERY 100 HOURS	EVERY SEASON	BEFORE STORAGE					
TRACTOR	Check Brake Operation	✓		✓										
	Check Tire Pressure	✓		✓										
	Check for Loose Fasteners	✓							✓					
	Sharpen/Replace Mower Blades				✓ <sub>4</sub>									
	Lubrication Chart				✓				✓					
	Check Battery Level/Recharge				✓									
	Clean Battery and Terminals				✓					✓				
	Check Transmission Cooling				✓									
	Adjust Blade Belt(s) Tension							✓ <sub>5</sub>						
	Adjust Motion Drive Belt(s) Tension							✓ <sub>5</sub>						
ENGINE	Check Engine Oil Level	✓		✓										
	Change Engine Oil		✓		✓ <sub>1,2,3</sub>				✓					
	Clean Air Filter				✓ <sub>2</sub>									
	Clean Air Screen				✓ <sub>2</sub>									
	Inspect Muffler/Spark Arrester					✓								
	Replace Oil Filter (If equipped)							✓ <sub>1,2</sub>						
	Clean Engine Cooling Fins							✓ <sub>2</sub>						
	Replace Spark Plug							✓	✓					
	Replace Air Filter Paper Cartridge							✓ <sub>2</sub>						
	Replace Fuel Filter								✓					

1 - Change more often when operating under a heavy load or in high ambient temperatures.  
 2 - Service more often when operating in dirty or dusty conditions.

3 - If equipped with oil filter, change oil every 50 hours.  
 4 - Replace blades more often when mowing in sandy soil.  
 5 - If equipped with adjustable system.

## GENERAL RECOMMENDATIONS

The warranty on this tractor does not cover items that have been subjected to operator abuse or negligence. To receive full value from the warranty, operator must maintain tractor as instructed in this manual.

Some adjustments will need to be made periodically to properly maintain your tractor.

All adjustments in the Service and Adjustments section of this manual should be checked at least once each season.

- Once a year you should replace the spark plug, clean or replace air filter, and check blades and belts for wear. A new spark plug and clean air filter assure proper air-fuel mixture and help your engine run better and last longer.

## BEFORE EACH USE

- Check engine oil level.
- Check brake operation.
- Check tire pressure.
- Check for loose fasteners.

## LUBRICATION CHART

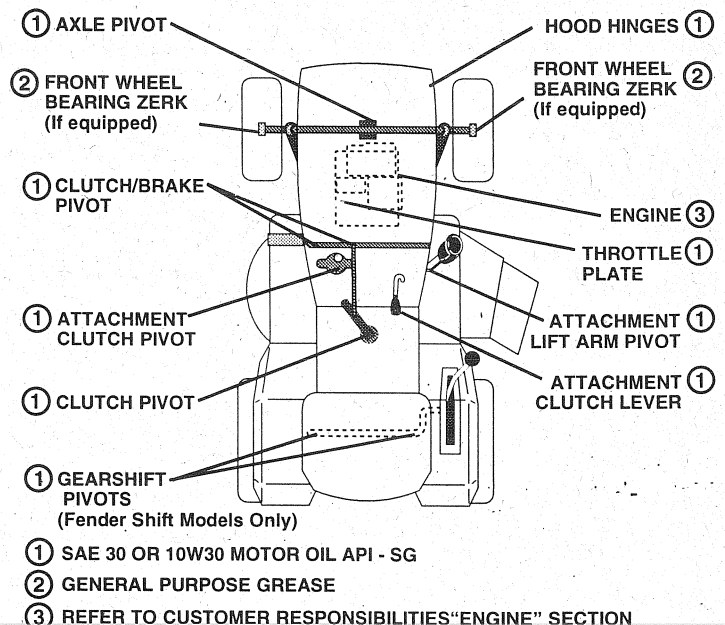

**IMPORTANT:** DO NOT OIL OR GREASE THE PIVOT POINTS WHICH HAVE SPECIAL NYLON BEARINGS. VISCOUS LUBRICANTS WILL ATTRACT DUST AND DIRT THAT WILL SHORTEN THE LIFE OF THE SELF-LUBRICATING BEARINGS. IF YOU FEEL THEY MUST BE LUBRICATED, USE ONLY A DRY, POWDERED GRAPHITE TYPE LUBRICANT SPARINGLY.

# CUSTOMER RESPONSIBILITIES

## TRACTOR

Always observe safety rules when performing any maintenance.

## BRAKE OPERATION

If unit requires more than six (6) feet stopping distance at high speed in highest gear, then brake must be adjusted. (See "TO ADJUST BRAKE" in Service and Adjustments section of this manual).

## TIRES

- Maintain proper air pressure in all tires - 14 PSI in front tires and 12 PSI in rear tires.
- Keep tires free of gasoline, oil, or insect control chemicals which can harm rubber.
- Avoid stumps, stones, deep ruts, sharp objects and other hazards that may cause tire damage.

## BLADE CARE

For best results mower blades must be kept sharp. Replace bent or damaged blades.

## BLADE REMOVAL (See Fig. 14A)

- Raise mower to highest position to allow access to blades.
- Remove hex bolt, lock washer and flat washer securing blade.
- Install new or resharpened blade with trailing edge up towards deck as shown.
- Reassemble hex bolt, lock washer and flat washer in exact order as shown.
- Tighten bolt securely (30-35 Ft. Lbs. torque).

**IMPORTANT:** BLADE BOLT IS GRADE 8 HEAT TREATED.

**NOTE:** We do not recommend sharpening blade -- but if you do, be sure the blade is balanced.

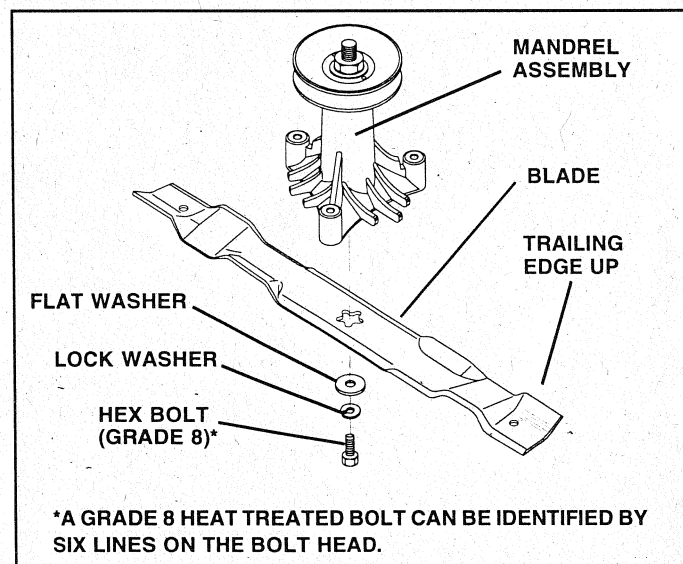

FIG. 14A

## TO SHARPEN BLADE (See Fig. 14B)

Care should be taken to keep the blade balanced. An unbalanced blade will cause excessive vibration and eventual damage to mower and engine.

- The blade can be sharpened with a file or on a grinding wheel. Do not attempt to sharpen while on the mower.
- To check blade balance, you will need a 5/8" diameter steel bolt, pin, or a cone balancer. (When using a cone balancer, follow the instructions supplied with balancer).
- Slide blade on to an unthreaded portion of the steel bolt or pin and hold the bolt or pin parallel with the ground. If blade is balanced, it should remain in a horizontal position. If either end of the blade moves downward, sharpen the heavy end until the blade is balanced.

**NOTE:** Do not use a nail for balancing blade. The lobes of the center hole may appear to be centered, but are not.

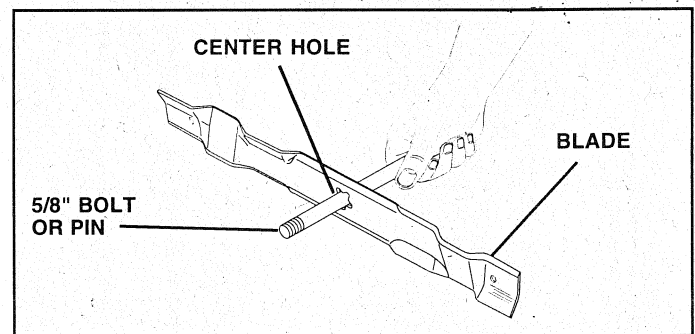

FIG. 14B

## BATTERY (See Fig. 15)

Your unit has a battery charging system which is sufficient for normal use. However, periodic charging of the battery with an automotive charger will extend its life.

- Acid solution level in each battery cell should be even with bottoms of vent wells. Add only distilled or iron free water if necessary. Do not overfill.
- Keep battery and terminals clean.
- Keep battery bolts tight.
- Keep vent caps tight and small vent holes in caps open.
- Recharge at 6 amperes for 1 hour.

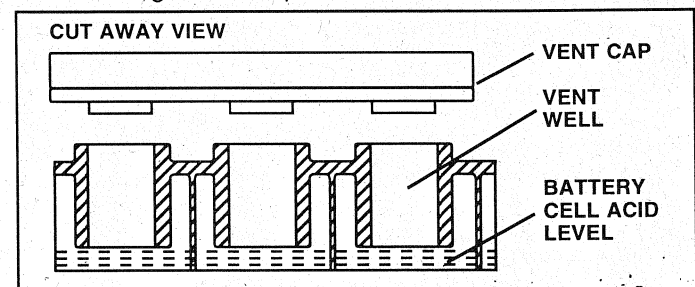

FIG. 15

# CUSTOMER RESPONSIBILITIES

## TO CLEAN BATTERY AND TERMINALS -

Corrosion and dirt on the battery and terminals can cause the battery to "leak" power.

- Remove terminal guard.
- Disconnect BLACK battery cable first then RED battery cable and remove battery from tractor.
- Wash battery with solution of four tablespoons of baking soda to one gallon of water. Be careful not to get the soda solution into the cells.
- Rinse the battery with plain water and dry.
- Clean terminals and battery cable ends with wire brush until bright.
- Coat terminals with grease or petroleum jelly.
- Reinstall battery (See "INSTALL BATTERY" in the Assembly section of this manual).

## V- BELTS

Check V-Belts for deterioration and wear after 100 hours. Replace if necessary. The belts are not adjustable. Replace belts if they begin to slip from wear.

## TRANSAXLE COOLING

Keep transaxle free from build-up of dirt and chaff which can restrict cooling.

## ENGINE

### LUBRICATION

Change the oil after the first two hours of operation and every 25 hours thereafter or at least once a year if the tractor is not used for 25 hours in one year. Refer to engine manual.

### AIR FILTER

Your engine will not run properly and may be damaged by using a dirty air filter. Remove cartridge every 25 hours and tap gently to clean. Replace paper cartridge once a year or after every 100 hours of operation, more often if used in very dusty, dirty conditions. See engine manual.

- Remove knobs and cover.
- Remove cartridge nut and clean or replace cartridge.
- Reassemble and tighten securely.

**NOTE:** Do not attempt to oil the paper cartridge. See engine manual.

### AIR SCREEN

The engine air screen must be kept free of dirt and chaff to prevent engine damage from overheating. Clean with a wire brush or compressed air to remove dirt and stubborn dried gum fibers. See engine manual.

## ENGINE COOLING FINS

Remove any dust, dirt or oil from engine cooling fins to prevent engine damage from overheating. See engine manual.

## MUFFLER

Inspect and replace corroded muffler and spark arrester (if equipped) as it could create a fire hazard and/or damage.

## SPARK PLUGS

Replace spark plugs at the beginning of each mowing season or after every 100 hours of use, whichever comes first. Gap should be set at .030 inch.

## IN-LINE FUEL FILTER (See Fig. 16)

Fuel filter should be replaced once each season. If fuel filter becomes clogged, obstructing fuel flow to carburetor, replacement is required.

- With engine cool, remove filter and plug fuel line sections.
- Place new fuel filter in position in fuel line.
- Be sure there are no fuel line leaks and clamps are properly positioned.
- Immediately wipe up any spilled gasoline.

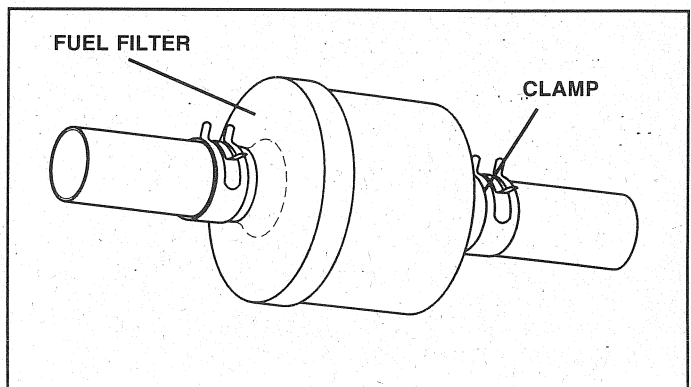

FIG. 16

## CLEANING

- Clean engine, battery, seat, finish, etc. of all foreign matter.
- Keep finished surfaces and wheels free of all gasoline, oil, etc.
- Protect painted surfaces with automotive type wax.

We do not recommend using a garden hose to clean your unit unless the electrical system, muffler, air filter and carburetor are covered to keep water out. Water in engine can result in a shortened engine life.

# SERVICE AND ADJUSTMENTS

## CAUTION: BEFORE PERFORMING ANY SERVICE OR ADJUSTMENTS:



- Depress clutch/brake pedal fully and set parking brake.
- Place gearshift lever in "NEUTRAL" position.
- Place attachment clutch in "DISENGAGED" position.
- Turn ignition key "OFF" and remove key.
- Make sure the blades and all moving parts have completely stopped.
- Disconnect spark plug wire from spark plug and place wire where it cannot come in contact with plug.

## TRACTOR

### TO REMOVE MOWER (See Fig. 17)

Mower will be easier to remove from the right side of unit.

- Park tractor on a level surface and engage parking brake.
- Remove key from ignition.
- Be sure that mower clutch lever is in "DISENGAGED" position.
- Lower mower deck to lowest cutting position.
- Remove retainer spring and washer that holds mower clutch spring to the mower clutch arm.
- Disconnect mower clutch spring from mower clutch arm.
- Remove retainer springs and washers from mower stabilizer link.
- Remove retainer springs and washers from rear lift links.
- Remove retainer spring and washer from front lift link.
- Withdraw front lift link, rear lift links and mower stabilizer link from brackets.
- Remove belt from engine pulley.
- Raise mower lift handle to transport position.
- Turn front tires to left.
- Slide mower deck out on right side of tractor.

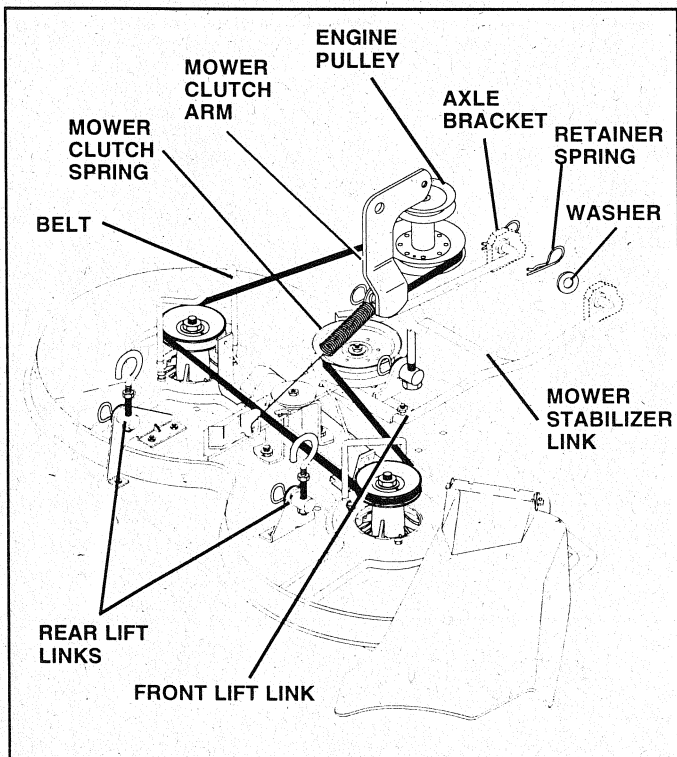

FIG. 17

### TO INSTALL MOWER (See Fig. 17)

- Reverse removal instructions.

### MOWER UPSTOP ADJUSTMENT (See Fig. 18)

- Raise mower lift lever to highest (transport) position.
- Measure distance from top of mower deck to lower flange of chassis (dim. "A").
- Dim. "A" should be 3-3/8 to 3-1/2 inches.
- To adjust dim. "A", if required, lower mower to lowest position. Remove washer and hairpin clip in trunnion, then withdraw trunnion pin from bracket. Loosen trunnion locknut and rotate trunnion counterclockwise on lift link to increase dim. "A" or clockwise on lift link to decrease dim. "A".
- Tighten lower trunnion locknut.

**NOTE:** Each full turn of trunnion will change dim. "A" by 1/16 inch. Re-insert trunnion into bracket with pin pointing to L.H. side of unit. Re-install washer and spring retainer.

- Raise lift lever to highest position and recheck dim. "A". Repeat adjustment if necessary.

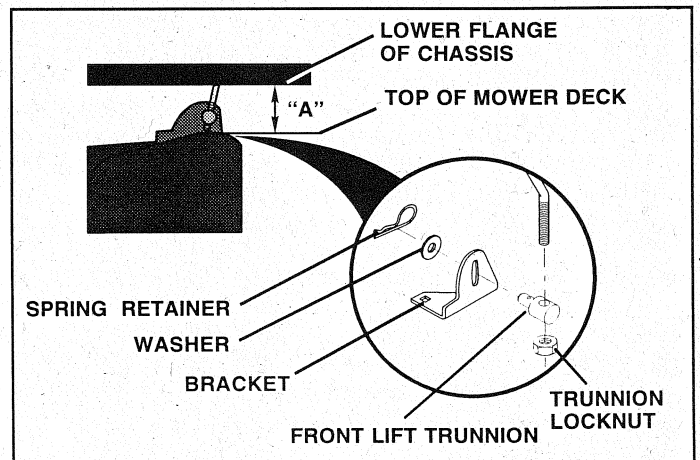

FIG. 18



# SERVICE AND ADJUSTMENTS

## TO LEVEL MOWER HOUSING (See Figs. 19 - Fig. 22)

Adjust the mower while tractor is parked on level ground or driveway. Make sure tires are properly inflated. If tires are over or under inflated, you will not properly adjust your mower.

**NOTE:** One rotation of trunnion nut is equivalent to approximately 1/8 inch of height change. Be sure upper and lower nuts are tightened against trunnion after adjustment has been completed.

- Place mower height adjustment knob in position "3" (See Fig. 19).
- Lower mower lift lever to height adjustment knob.

## SIDE-TO-SIDE ADJUSTMENT (See Figs. 20 and 21) -

- Measure distance from ground to lower flange of mower deck on both sides of mower (dim. "B" & "C"). Dim. "B" & "C" should be the same.

Level the mower side-to-side by adjusting the left rear lift link.

- To raise left side of mower, loosen upper trunnion nut tighten and lower trunnion nut.
- To lower left side of mower, loosen lower trunnion nut and tighten upper trunnion nut.

## FRONT-TO-BACK ADJUSTMENT (See Figs. 21 and 22)-

To obtain the best cutting results, the mower housing should be adjusted so the rear is approximately 1/4" to 3/4" higher than the front when the mower is in height adjustment position "3".

- Measure distance from ground line to lower flange of deck at right front and right rear (dim. "D" & "E") in line with front and rear tires.

Raise or lower rear of mower housing by adjusting the right rear lift link.

- To raise rear of mower housing, loosen upper trunnion nut and tighten lower trunnion nut.
- To lower rear of mower housing, loosen the lower trunnion nut and tighten upper trunnion nut.
- Recheck side-to-side adjustment.

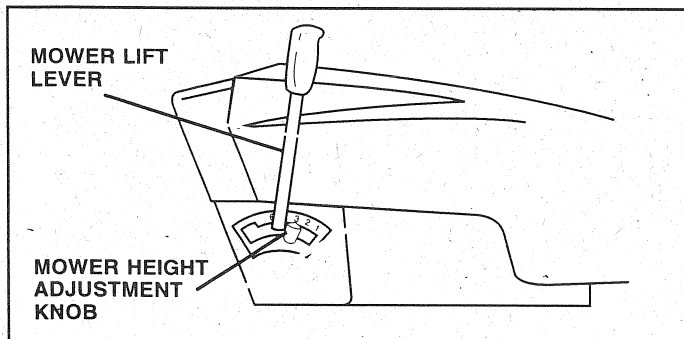

FIG. 19

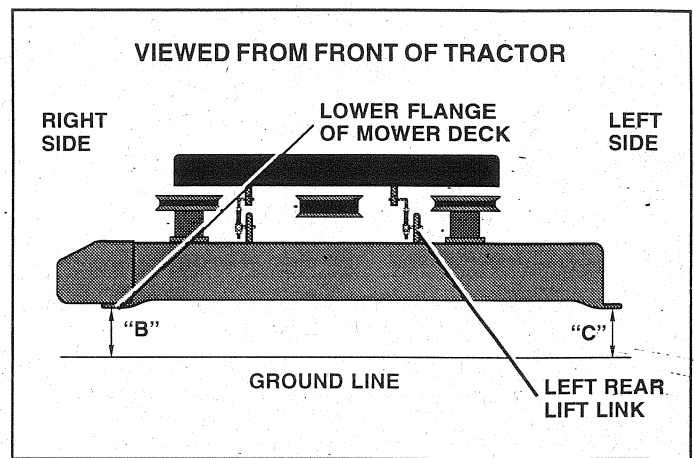

FIG. 20

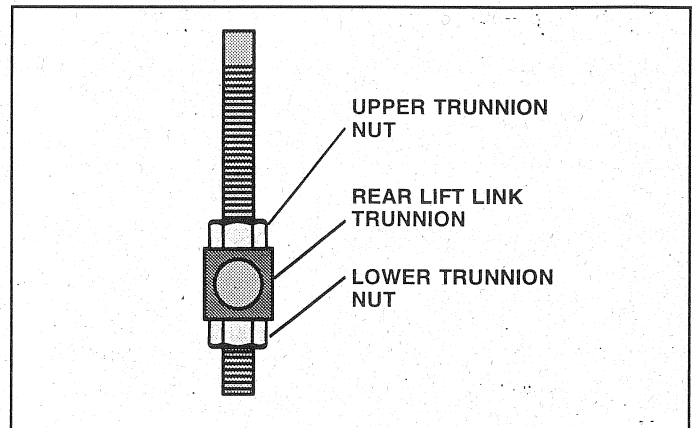

FIG. 21

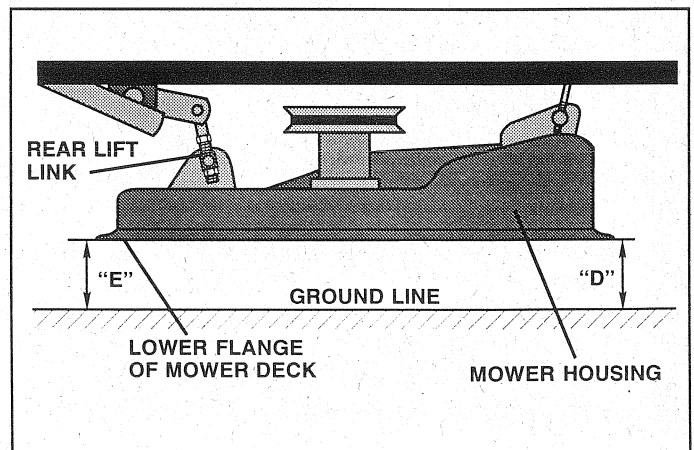

FIG. 22

# SERVICE AND ADJUSTMENTS

## TO ADJUST BRAKE (See Fig. 23)

Your unit is equipped with an adjustable brake system which is mounted on the right side of the transaxle.

If unit requires more than six (6) feet stopping distance at high speed in highest gear, then brake must be adjusted.

- Depress clutch/brake pedal and engage parking brake.
- Measure distance between brake operating arm and nut "A" on brake rod.
- If distance is other than 1-5/8", disengage parking brake, loosen jam nut and turn nut "A" until distance becomes 1-5/8". Retighten jam nut against nut "A".
- Engage parking brake and recheck distance.
- Road test unit for proper stopping distance as stated above. Readjust if necessary. If stopping distance is still greater than six (6) feet in highest gear, further maintenance is necessary. Contact your nearest authorized service center.

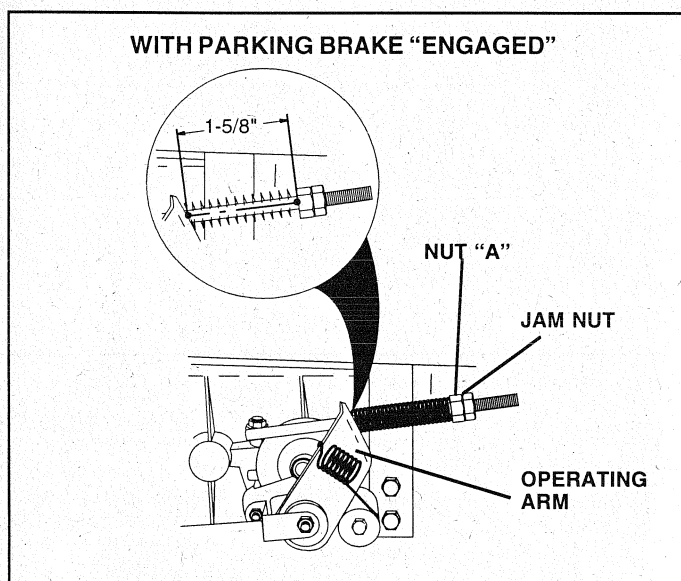

FIG. 23

## TO REPLACE MOTION DRIVE BELT (See Fig. 24)

Park the tractor on level area. Engage parking brake. For assistance, there is a belt installation guide decal on bottom side of left footrest.

- Engage parking brake.
- Lower mower lift lever to "lowest" position.
- Turn front wheels fully to left or right.
- Disconnect mower drive belt at engine pulley.
- Disconnect motion drive belt at clutching idler.
- Disconnect motion drive belt at transaxle. Push above transaxle pulley.
- Disconnect motion drive belt at frame belt keeper.
- Disconnect motion drive belt at engine pulley. Thread belt below mower drive sheave and through engine belt keeper and engine pulley.
- Remove belt.
- Install new belt by reversing above procedure.
- Make sure that belt is inside all belt keepers.

**IMPORTANT:** REPLACE ONLY WITH BELT SPECIFIED BY ORIGINAL EQUIPMENT MANUFACTURER.

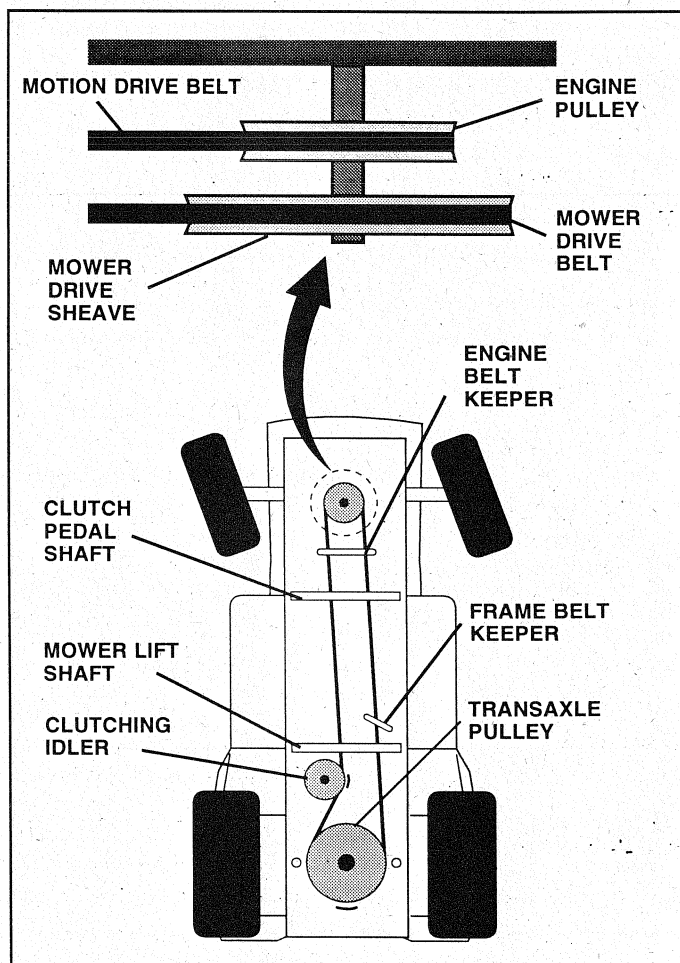

FIG. 24

# SERVICE AND ADJUSTMENTS

## TO ADJUST STEERING WHEEL ALIGNMENT

If steering wheel crossbars are not horizontal (left to right) when wheels are positioned straight forward, remove steering wheel and reassemble per instructions in the Assembly section of this manual.

## FRONT WHEEL TOE-IN/CAMBER

The front wheel toe-in and camber are not adjustable on your unit. If damage has occurred to affect the front wheel toe-in or camber, contact your nearest authorized service center.

## TO REMOVE WHEEL FOR REPAIRS (See Fig. 25)

- Block up axle securely.
- Remove axle cap, retaining ring and washers to allow wheel removal (rear wheel contains a square key - Do not lose).
- Repair tire and reassemble.
- On rear wheels only: align grooves in rear wheel hub and axle. Insert square key.
- Replace washers and snap retaining ring securely in axle groove.
- Replace axle cap.

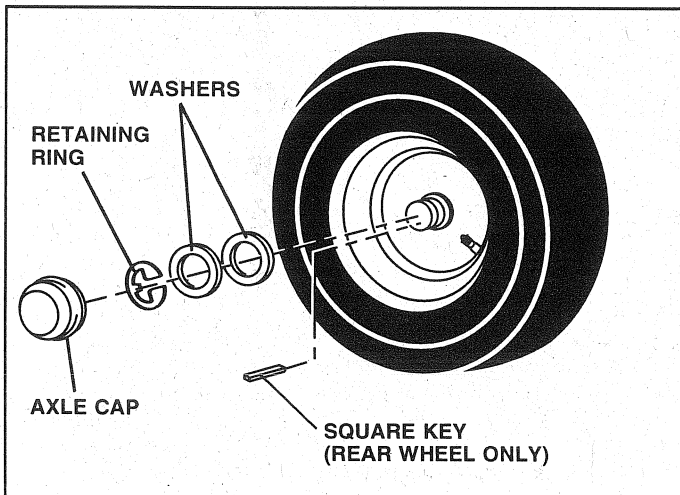

FIG. 25

## TO START ENGINE WITH A WEAK BATTERY (See Fig. 26)



**CAUTION:** Lead-acid batteries generate explosive gases. Keep sparks, flame and smoking materials away from batteries. Always wear eye protection when around batteries.

If your battery is too weak to start the engine, it should be recharged. If "jumper cables" are used for emergency starting, follow this procedure:

**IMPORTANT:** YOUR UNIT IS EQUIPPED WITH A 12 VOLT NEGATIVE GROUND SYSTEM. THE OTHER VEHICLE MUST ALSO BE A 12 VOLT NEGATIVE GROUND SYSTEM. DO NOT USE YOUR TRACTOR BATTERY TO START OTHER VEHICLES.

## TO ATTACH JUMPER CABLES -

- Connect each end of the RED cable to the POSITIVE (+) terminal of each battery, taking care not to short against chassis.
- Connect one end of the BLACK cable to the NEGATIVE (-) terminal of fully charged battery.
- Connect the other end of the BLACK cable to good CHASSIS GROUND, away from fuel tank and battery.

## TO REMOVE CABLES, REVERSE ORDER -

- BLACK cable first from chassis and then from the fully charged battery.
- RED cable last from both batteries.

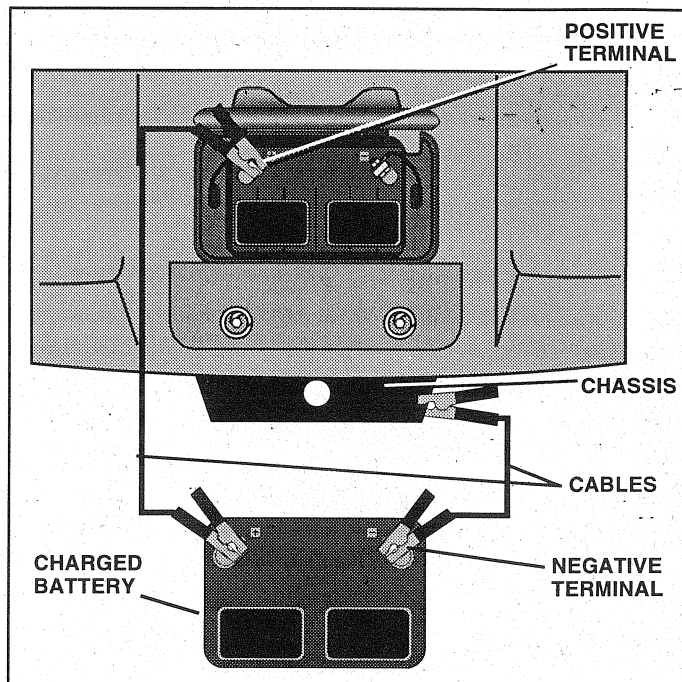

FIG. 26

## TO REPLACE FUSE

Replace with 30 amp automotive-type plug-in fuse. The fuse holder is located next to the battery box and is accessible from left rear wheel area.

## ENGINE

### TO ADJUST CARBURETOR

The carburetor has been preset at the factory and adjustment should not be necessary. However, minor adjustment may be required to compensate for differences in fuel, temperature, altitude or load. If the carburetor does need adjustment, see engine manual.

**IMPORTANT:** NEVER TAMPER WITH THE ENGINE GOVERNOR, WHICH IS FACTORY SET FOR PROPER ENGINE SPEED. OVERSPEEDING THE ENGINE ABOVE THE FACTORY HIGH SPEED SETTING CAN BE DANGEROUS. IF YOU THINK THE ENGINE-GOVERNED HIGH SPEED NEEDS ADJUSTING, CONTACT YOUR NEAREST AUTHORIZED SERVICE CENTER, WHICH HAS PROPER EQUIPMENT AND EXPERIENCE TO MAKE ANY NECESSARY ADJUSTMENTS.

# STORAGE

Immediately prepare your tractor for storage at the end of the season or if the tractor will not be used for 30 days or more.



**CAUTION:** Never store the tractor with gasoline in the tank inside a building where fumes may reach an open flame or spark. Allow the engine to cool before storing in any enclosure.

## TRACTOR

Remove mower from tractor for winter storage. When mower is to be stored for a period of time, clean it thoroughly, remove all dirt, grease, leaves, etc. Store in a clean, dry area.

- Clean entire tractor (See "CLEANING" in the Customer Responsibilities section of this manual).
- Inspect and replace belts, if necessary (See belt replacement instructions in the Service and Adjustments section of this manual).
- Lubricate as shown in the Customer Responsibilities section of this manual.
- Be sure that all nuts, bolts and screws are securely fastened. Inspect moving parts for damage, breakage and wear. Replace if necessary.
- Touch up all rusted or chipped paint surfaces; sand lightly before painting.

## BATTERY

- Fully charge the battery for storage.
- After a period of time in storage, battery may require recharging.
- To help prevent corrosion and power leakage during long periods of storage, battery cables should be disconnected and battery cleaned thoroughly (see "TO CLEAN BATTERY AND TERMINALS" in the Customer Responsibilities section of this manual).
- After cleaning, leave cables disconnected and place cables where they cannot come in contact with battery terminals.
- Be sure battery drain tube is securely attached.
- If battery is removed from tractor for storage, do not store battery directly on concrete or damp surfaces.

## ENGINE

### FUEL SYSTEM

**IMPORTANT:** IT IS IMPORTANT TO PREVENT GUM DEPOSITS FROM FORMING IN ESSENTIAL FUEL SYSTEM PARTS SUCH AS CARBURETOR, FUEL FILTER, FUEL HOSE, OR TANK DURING STORAGE. ALSO, EXPERIENCE INDICATES THAT ALCOHOL BLENDED FUELS (CALLED GASOHOL OR USING ETHANOL OR METHANOL) CAN ATTRACT MOISTURE WHICH LEADS TO SEPARATION AND FORMATION OF ACIDS DURING STORAGE. ACIDIC GAS CAN DAMAGE THE FUEL SYSTEM OF AN ENGINE WHILE IN STORAGE.

- Drain the fuel tank.
- Start the engine and let it run until the fuel lines and carburetor are empty.
- Never use engine or carburetor cleaner products in the fuel tank or permanent damage may occur.
- Use fresh fuel next season.

**NOTE:** Fuel stabilizer is an acceptable alternative in minimizing the formation of fuel gum deposits during storage. Add stabilizer to gasoline in fuel tank or storage container. Always follow the mix ratio found on stabilizer container. Run engine at least 10 minutes after adding stabilizer to allow the stabilizer to reach the carburetor. Do not drain the gas tank and carburetor if using fuel stabilizer.

### ENGINE OIL

Drain oil (with engine warm) and replace with clean engine oil. (See "ENGINE" in the Customer Responsibilities section of this manual).

### CYLINDERS

- Remove spark plug(s).
- Pour one ounce of oil through spark plug hole(s) into cylinder(s).
- Turn ignition key to "START" position for a few seconds to distribute oil.
- Replace with new spark plug(s).

## OTHER

- Do not store gasoline from one season to another.
- Replace your gasoline can if your can starts to rust. Rust and/or dirt in your gasoline will cause problems.
- If possible, store your tractor indoors and cover it to give protection from dust and dirt.
- Cover your tractor with a suitable protective cover that does not retain moisture. Do not use plastic. Plastic cannot breathe which allows condensation to form and will cause your tractor to rust.

**IMPORTANT:** NEVER COVER TRACTOR WHILE ENGINE AND EXHAUST ARE STILL WARM.

# SCHEMATIC

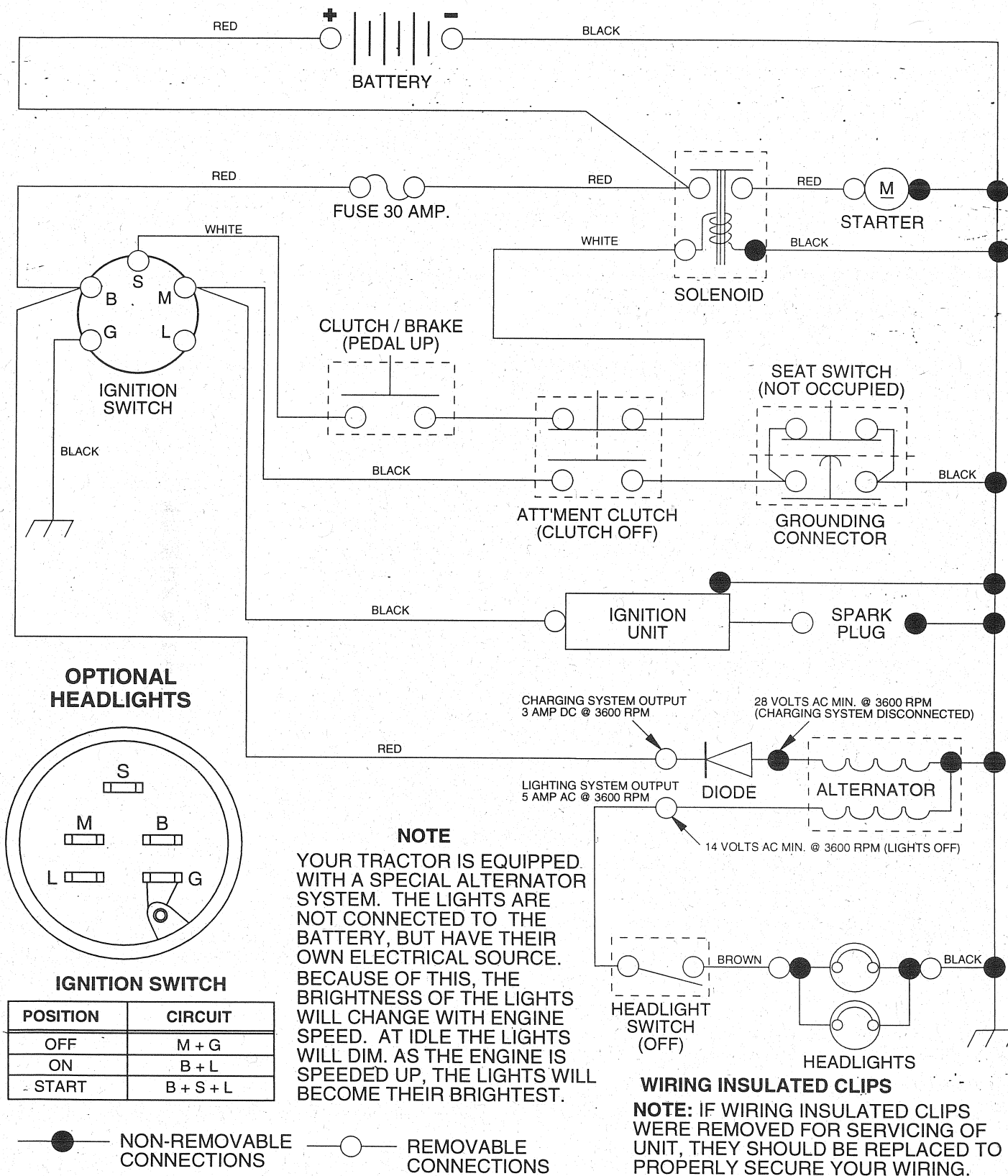

## OPTIONAL HEADLIGHTS

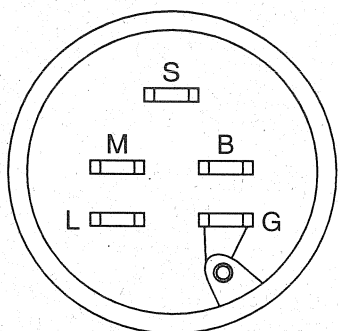

## IGNITION SWITCH

POSITION	CIRCUIT
OFF	M + G
ON	B + L
START	B + S + L

**NOTE**  
 YOUR TRACTOR IS EQUIPPED WITH A SPECIAL ALTERNATOR SYSTEM. THE LIGHTS ARE NOT CONNECTED TO THE BATTERY, BUT HAVE THEIR OWN ELECTRICAL SOURCE. BECAUSE OF THIS, THE BRIGHTNESS OF THE LIGHTS WILL CHANGE WITH ENGINE SPEED. AT IDLE THE LIGHTS WILL DIM. AS THE ENGINE IS SPEEDED UP, THE LIGHTS WILL BECOME THEIR BRIGHTEST.

## WIRING INSULATED CLIPS

**NOTE:** IF WIRING INSULATED CLIPS WERE REMOVED FOR SERVICING OF UNIT, THEY SHOULD BE REPLACED TO PROPERLY SECURE YOUR WIRING.

# TROUBLESHOOTING POINTS

PROBLEM	CAUSE	CORRECTION
<b>Will not start</b>	<ol style="list-style-type: none"> <li>1. Out of fuel.</li> <li>2. Engine not "CHOKED" properly.</li> <li>3. Engine flooded.</li> <li>4. Bad spark plug.</li> <li>5. Dirty air filter.</li> <li>6. Dirty fuel filter.</li> <li>7. Water in fuel.</li> <li>8. Loose or damaged wiring.</li> <li>9. Carburetor out of adjustment.</li> <li>10. Engine valves out of adjustment.</li> </ol>	<ol style="list-style-type: none"> <li>1. Fill fuel tank.</li> <li>2. See "TO START ENGINE" in Operation section.</li> <li>3. Wait several minutes before attempting to start.</li> <li>4. Replace spark plug.</li> <li>5. Clean/replace air filter.</li> <li>6. Replace fuel filter.</li> <li>7. Drain fuel tank and carburetor, refill tank with fresh gasoline and replace fuel filter.</li> <li>8. Check all wiring.</li> <li>9. Contact an authorized service center/department.</li> <li>10. Contact an authorized service center/department.</li> </ol>
<b>Hard to start</b>	<ol style="list-style-type: none"> <li>1. Dirty air filter.</li> <li>2. Bad spark plug.</li> <li>3. Weak or dead battery.</li> <li>4. Dirty fuel filter.</li> <li>5. Stale or dirty fuel.</li> <li>6. Loose or damaged wiring.</li> <li>7. Carburetor out of adjustment.</li> <li>8. Engine valves out of adjustment.</li> </ol>	<ol style="list-style-type: none"> <li>1. Clean/replace air filter.</li> <li>2. Replace spark plug.</li> <li>3. Recharge or replace battery.</li> <li>4. Replace fuel filter.</li> <li>5. Drain fuel tank and refill with fresh gasoline.</li> <li>6. Check all wiring.</li> <li>7. Contact an authorized service center/department.</li> <li>8. Contact an authorized service center/department.</li> </ol>
<b>Engine will not turn over</b>	<ol style="list-style-type: none"> <li>1. Clutch/brake pedal not depressed.</li> <li>2. Attachment clutch is engaged.</li> <li>3. Weak or dead battery.</li> <li>4. Blown fuse.</li> <li>5. Corroded battery terminals.</li> <li>6. Loose or damaged wiring.</li> <li>7. Faulty ignition switch.</li> <li>8. Faulty solenoid or starter.</li> <li>9. Faulty operator presence switch(es).</li> </ol>	<ol style="list-style-type: none"> <li>1. Depress clutch/brake pedal.</li> <li>2. Disengage attachment clutch.</li> <li>3. Recharge or replace battery.</li> <li>4. Replace fuse.</li> <li>5. Clean battery terminals.</li> <li>6. Check all wiring.</li> <li>7. Check/replace ignition switch.</li> <li>8. Check/replace solenoid or starter.</li> <li>9. Contact an authorized service center/department.</li> </ol>
<b>Engine clicks but will not start</b>	<ol style="list-style-type: none"> <li>1. Weak or dead battery.</li> <li>2. Corroded battery terminals.</li> <li>3. Loose or damaged wiring.</li> <li>4. Faulty solenoid or starter.</li> </ol>	<ol style="list-style-type: none"> <li>1. Recharge or replace battery.</li> <li>2. Clean battery terminals.</li> <li>3. Check all wiring.</li> <li>4. Check/replace solenoid or starter.</li> </ol>
<b>Loss of power</b>	<ol style="list-style-type: none"> <li>1. Cutting too much grass/too fast.</li> <li>2. Throttle in "CHOKE" position.</li> <li>3. Build-up of grass, leaves and trash under mower.</li> <li>4. Dirty air filter.</li> <li>5. Low oil level/dirty oil.</li> <li>6. Faulty spark plug.</li> <li>7. Dirty fuel filter.</li> <li>8. Stale or dirty fuel.</li> <li>9. Water in fuel.</li> <li>10. Spark plug wire loose.</li> <li>11. Dirty engine air screen/fins.</li> <li>12. Dirty/clogged muffler.</li> <li>13. Loose or damaged wiring.</li> <li>14. Carburetor out of adjustment.</li> <li>15. Engine valves out of adjustment.</li> </ol>	<ol style="list-style-type: none"> <li>1. Set in "Higher Cut" position/reduce speed.</li> <li>2. Adjust throttle control.</li> <li>3. Clean underside of mower housing.</li> <li>4. Clean/replace air filter.</li> <li>5. Check oil level/change oil.</li> <li>6. Clean and regap or change spark plug.</li> <li>7. Replace fuel filter.</li> <li>8. Drain fuel tank and refill with fresh gasoline.</li> <li>9. Drain fuel tank and carburetor, refill tank with fresh gasoline and replace fuel filter.</li> <li>10. Connect and tighten spark plug wire.</li> <li>11. Clean engine air screen/fins.</li> <li>12. Clean/replace muffler.</li> <li>13. Check all wiring.</li> <li>14. Contact an authorized service center/department.</li> <li>15. Contact an authorized service center/department.</li> </ol>
<b>Excessive vibration</b>	<ol style="list-style-type: none"> <li>1. Worn, bent or loose blade.</li> <li>2. Bent blade mandrel.</li> <li>3. Loose/damaged part(s).</li> </ol>	<ol style="list-style-type: none"> <li>1. Replace blade. Tighten blade bolt.</li> <li>2. Replace blade mandrel.</li> <li>3. Tighten loose part(s). Replace damaged parts.</li> </ol>

# TROUBLESHOOTING POINTS

PROBLEM	CAUSE	CORRECTION
Engine continues to run when operator leaves seat with attachment clutch engaged	<ol style="list-style-type: none"> <li>1. Faulty operator-safety presence control system.</li> </ol>	<ol style="list-style-type: none"> <li>1. Check wiring, switches and connections. If not corrected, contact an authorized service center/department.</li> </ol>
Poor cut - uneven	<ol style="list-style-type: none"> <li>1. Worn, bent or loose blade.</li> <li>2. Mower deck not level.</li> <li>3. Buildup of grass, leaves, and trash under mower.</li> <li>4. Bent blade mandrel.</li> <li>5. Clogged mower deck vent holes from buildup of grass, leaves, and trash around mandrels.</li> </ol>	<ol style="list-style-type: none"> <li>1. Replace blade. Tighten blade bolt.</li> <li>2. Level mower deck.</li> <li>3. Clean underside of mower housing.</li> <li>4. Replace blade mandrel.</li> <li>5. Clean around mandrels to open vent holes.</li> </ol>
Mower blades will not rotate	<ol style="list-style-type: none"> <li>1. Obstruction in clutch mechanism.</li> <li>2. Worn/damaged mower drive belt.</li> <li>3. Frozen idler pulley.</li> <li>4. Frozen blade mandrel.</li> </ol>	<ol style="list-style-type: none"> <li>1. Remove obstruction.</li> <li>2. Replace mower drive belt.</li> <li>3. Replace idler pulley.</li> <li>4. Replace blade mandrel.</li> </ol>
Poor grass discharge	<ol style="list-style-type: none"> <li>1. Engine speed too slow.</li> <li>2. Travel speed too fast.</li> <li>3. Wet grass.</li> <li>4. Mower deck not level.</li> <li>5. Low/uneven tire air pressure.</li> <li>6. Worn, bent or loose blade.</li> <li>7. Buildup of grass, leaves and trash under mower.</li> <li>8. Mower drive belt worn.</li> <li>9. Blades improperly installed.</li> <li>10. Improper blades used.</li> <li>11. Clogged mower deck vent holes from buildup of grass, leaves, and trash around mandrels.</li> </ol>	<ol style="list-style-type: none"> <li>1. Place throttle control in "FAST" position.</li> <li>2. Shift to slower speed.</li> <li>3. Allow grass to dry before mowing.</li> <li>4. Level mower deck.</li> <li>5. Check tires for proper air pressure.</li> <li>6. Replace/sharpen blade. Tighten blade bolt.</li> <li>7. Clean underside of mower housing.</li> <li>8. Replace mower drive belt.</li> <li>9. Reinstall blades sharp edge down.</li> <li>10. Replace with blades listed in this manual.</li> <li>11. Clean around mandrels to open vent holes.</li> </ol>
Headlight(s) not working (if so equipped)	<ol style="list-style-type: none"> <li>1. Switch is "OFF".</li> <li>2. Bulb(s) burned out.</li> <li>3. Faulty light switch.</li> <li>4. Loose or damaged wiring.</li> <li>5. Blown fuse.</li> </ol>	<ol style="list-style-type: none"> <li>1. Turn switch "ON".</li> <li>2. Replace bulb(s).</li> <li>3. Check/replace light switch.</li> <li>4. Check wiring and connections.</li> <li>5. Replace fuse.</li> </ol>
Battery will not charge	<ol style="list-style-type: none"> <li>1. Bad battery cell(s).</li> <li>2. Poor cable connections.</li> <li>3. Faulty regulator (if so equipped).</li> <li>4. Faulty alternator.</li> </ol>	<ol style="list-style-type: none"> <li>1. Replace battery.</li> <li>2. Check/clean all connections.</li> <li>3. Replace regulator.</li> <li>4. Replace alternator.</li> </ol>
Engine "backfires" when turning engine "OFF"	<ol style="list-style-type: none"> <li>1. Engine throttle control not set at "SLOW" position for 30 seconds before stopping engine.</li> </ol>	<ol style="list-style-type: none"> <li>1. Move throttle control to "SLOW" position and allow to idle for 30 seconds before stopping engine.</li> </ol>

# SERVICE NOTES

---



# SUGGESTED GUIDE FOR SIGHTING SLOPES FOR SAFE OPERATION

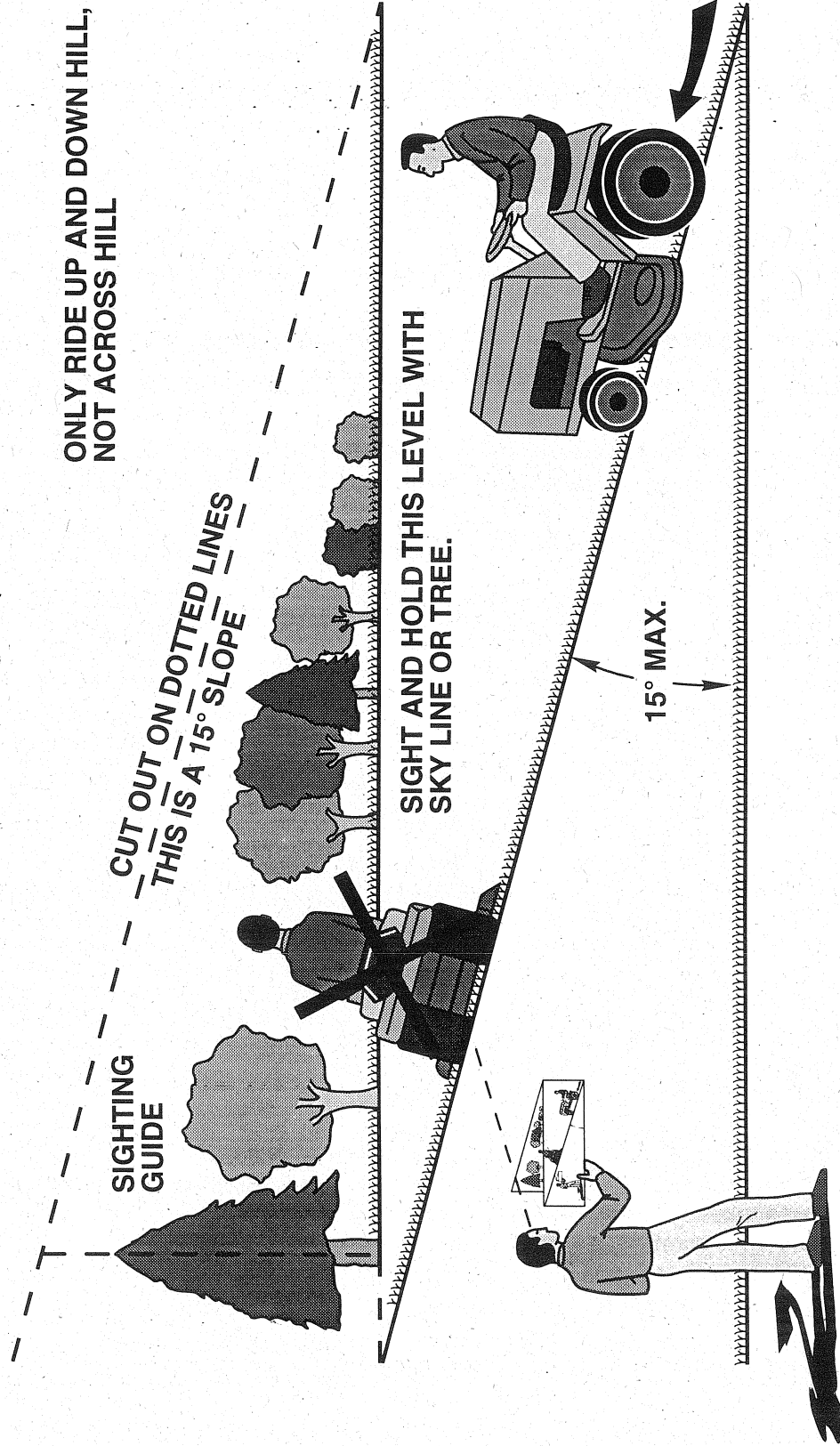

 Operate your Tractor up and down the face of slopes (not greater than 15°), never across the face. Make turns gradually to prevent tipping or loss of control. Exercise extreme caution when changing direction on slopes.

**LIMITED WARRANTY**  
**DANA CORPORATION**  
**Spicer-Off-Highway Axle Division**  
**Fredericktown, OH 43019**

Dana Corporation, Spicer-Off-Highway Axle Division, will at its options, replace or repair without charge to the original purchaser for materials or labor, any part or parts manufactured by it and found upon examination to be DEFECTIVE IN MATERIAL AND OR WORKMANSHIP, if received for examination within TWO YEARS\* from the date of original purchase.

All transportation charges on and damage or loss incurred in connection with the transportation of parts submitted for replacement or repair under this LIMITED WARRANTY shall be borne by the purchaser.

The EXPRESSED WARRANTY contained herein shall not apply to any damage resulting from accident, abuse, or neglect. Nor will this LIMITED WARRANTY apply to damage resulting from failure to follow the manufacturer's instructions for operation and maintenance nor from improper selection of a particular application.

The foregoing EXPRESSED WARRANTY IS IN LIEU OF ALL OTHER EXPRESSED WARRANTIES. Dana Corporation, Spicer-Off-Highway Axle Division, neither assumes nor authorizes any other persons, natural or corporate, to assume for it any obligations or liability in connection with or with respect to any parts covered hereunder.

DANA CORPORATION, SPICER-OFF-HIGHWAY AXLE DIVISION, HEREBY DISCLAIMS ANY AND ALL IMPLIED WARRANTIES, INCLUDING, BUT NOT LIMITED TO WARRANTIES OF MERCHANTABILITY AND FITNESS FOR ANY PARTICULAR PURPOSE, TO THE EXTENT THAT SUCH DISCLAIMER IS NOT FORBIDDEN BY ANY APPLICABLE LAW. ANY IMPLIED WARRANTIES, INCLUDING BUT NOT LIMITED TO WARRANTIES OF MERCHANTABILITY AND FITNESS FOR ANY PARTICULAR PURPOSE WHICH DANA CORPORATION, SPICER-OFF-HIGHWAY AXLE DIVISION, IS SO FORBIDDEN TO DISCLAIM BY ANY APPLICABLE LAW, ARE LIMITED TO THE PERIODS OF THE EXPRESSED WARRANTY. DANA CORPORATION, SPICER-OFF-HIGHWAY AXLE DIVISION, SHALL IN NO EVENT BE LIABLE FOR ANY CONSEQUENTIAL, INCIDENTAL OR SPECIAL DAMAGES AND OR EXPENSES.

Some states do not allow limitations on warranties so the above limitation may not apply to you. This Warranty gives you specific legal rights, and you may also have other rights which vary from state to state.

This warranty does not cover transmission units used for commercial purposes.

**FOR ASSISTANCE IN LOCATING THE NEAREST DANA AUTHORIZED SERVICE,  
PLEASE CONTACT ONE OF THE DISTRIBUTORS LISTED BELOW:**

**ATLANTIC POWER, INC.**  
650 Howard Avenue  
Somerset, NJ 08873-1111  
201-356-8400

**ATLANTIC POWER, INC.**  
77 Green St., Route 106  
Foxboro, MA 02035  
508-543-6911

**BEBCO AIR COOLED ENGINES**  
2221 Second Ave., South  
Birmingham, AL 35233  
205-251-4600

**BILLIOU'S**  
1343 South Main Street  
Porterville, CA 93257  
209-784-4102

**BLUEMONT COMPANY**  
11101 Frankstown Road  
Pittsburgh, PA 15235  
412-242-2522

**CHILTON AIR COOLED ENGINES**  
319 4th Ave. South  
Nashville, TN 37215  
615-254-1634

**DIXIE SALES CO., INC.**  
5920 Summit Ave.  
Browns Summit, NC 27214  
919-375-7500

**GARDNER, INC.**  
1150 Chesapeake Ave.  
Columbus, OH 43212  
614-488-7951

**GRAYSON COMPANY**  
215 Spring St.  
Shreveport, LA 71162  
318-222-3871

**GULF COAST ENG.**  
4202 Russel Drive  
Corpus Christi, TX  
78048 512-888-6999

**MARR BROTHERS, INC.**  
423 E. Jefferson  
Dallas, TX 75203  
214-948-7387

**MEDART ENGINES & PARTS**  
100 Larkin Williams Ind. Ct.  
Fenton, MO 63026  
314-343-0505

**MEDART ENGINES & PARTS**  
15500 W. 109Th St.  
Lenexa, KS 66219  
913-888-8828

**RADCO DISTRIBUTORS INC.**  
4909 Victor Street  
Jacksonville, FL 32207  
904-733-7957

**RBI CORPORATION**  
101 Cedar Ridge Rd.  
Ashland, VA 23005  
804-550-2210

**SEDCO, INC.**  
4305 Steve Reynolds Blvd.  
Norcross, GA 30093  
404-925-4706

**SPITZER INDUSTRIAL PROD.**  
6601 N. Washington  
Thornton, CO 80229  
303-287-3414

**WISCONSIN MAGNETO, INC.**  
4727 N. Teutonia Ave.  
Milwaukee, WI 53209  
414-445-2800

**CANADA**

**AIR COOLED ENGINE PARTS**  
474 Bank Street  
Ottawa, Ontario K2P 1Z3  
613-235-5111

**AIR COOLED ENG. UNLIMITED**  
750 Oakdale Rd Unit 62  
Downsview, Ontario M3N 2Z4  
416-741-8006

**ATELIERS BOND INC.**  
2875 Jasmin Street  
St. Laurent, Quebec H9R 1H8  
514-336-3660

**ATLANTIC AIR COOLED ENGINES**  
21 Driscoll Crescent  
Moncton, New Brunswick E1C 8N6  
506-382-5961

**DELL'S AUTO ELECTRIC LTD**  
1044 Cannon St. East  
Hamilton, Ontario L7L 7V6  
416-549-4107

**LOBOMBARDS, LTD**  
55 St. Clair Street  
Chatham, Ontario N7M 5K5  
519-352-1060

**LACHANCE & FILS INC.**  
505, 17e Rue  
Quebec, Ontario G1J 2G8  
418-647-4500

**LAKESHORE AUTO ELEC. LTD**  
P.O. Box 367  
Cobourg, Ontario K9A 4L1

**LAMBERT ELECTRIC LTD**  
814 47th Street East  
Saskatoon, Saskatchewan S7K 0X4  
306-242-0370

**MURDOCH'S SMALL ENGINES**  
370 Dunlop Street West  
Barrie, Ontario L4N 1C2  
705-726-1086

**UNIVERSAL IGNITION & BATTERY INC.**  
105 Falcon Street  
London, Ontario N5W 4Z2  
416-453-8711



**SECTION 1: LIMITED WARRANTY**

Husqvarna Forest & Garden Company ("Husqvarna") warrants Husqvarna product to the original purchaser to be free from defective material and workmanship from the date of purchase for the "Warranty Period" here stated dependent upon the type of product use. Warranty period is as follows for products listed:

- 5 Year Warranty:** Plastic walk behind mower decks for noncommercial, noninstitutional or nonincome producing use.
- 2 Year Warranty:** Riding lawn mowers, yard and garden tractors, walk behind mowers, tillers and attachments for noncommercial, noninstitutional or nonincome producing use. Ignition coils or modules on the chain saws, clearing saws and trimmers
- 1 Year Warranty:** Chain saws, clearing saws, trimmers, blowers and batteries for noncommercial, noninstitutional or nonincome producing use
- 90 Day Warranty:** All Husqvarna product used for rental, commercial, professional, or income producing use
- 30 Day Warranty:** Husqvarna professional bow bars
- 30 Day Replacement Part Warranty:** Unless otherwise stated, replacement parts are warranted for 30 days from date of purchase.

**SECTION 2: HUSQVARNA'S OBLIGATIONS UNDER THE WARRANTY**

Husqvarna will remedy defects in material and workmanship during the warranty period by repairing or replacing, at Husqvarna's option, the defective component without charge for parts or labor.

**SECTION 3: ITEMS NOT COVERED BY THIS WARRANTY**

The following items are not covered by this warranty:

- (1) Normal customer maintenance items (i.e. belts, blades, blades, bladi, adapters, bulbs, filters, guide bars, lubricants, rewind springs, saw chain, spark plugs, starter ropes and lines).
- (2) Normal wear, normal adjustment, standard hardware or items worn through regular use.
- (3) Natural discoloration of material due to ultraviolet light
- (4) The replacement or maintenance of worn items.
- (5) Briggs & Stratton, Kawasaki and Kohler engines, including starters, generators, alternators, and accessories. These items are covered by the engine manufacturer's warranty as stated with the product information supplied at the time of purchase. All claims for specified engines, starters, generators, alternators and accessories should be sent to the appropriate manufacturer.
- (6) Agri-Fab, Footo, and Tecumseh-Peerless drive systems. These items are covered by the drive system manufacturer's warranty as stated with the product information supplied at the time of purchase. All claims for specified drive systems should be sent to the appropriate manufacturer.

**SECTION 4: EXCEPTIONS AND LIMITATIONS**

This warranty shall be inapplicable to defects resulting from the following:

- (1) Accident, abuse, misuse, negligence and neglect, including stale fuel, dirt abrasives, moisture, rust, corrosion, or any adverse reaction due to incorrect storage habits.

- (2) Failure to operate or maintain the unit in accordance with the Owner's/Operator's manual or instruction sheet furnished by Husqvarna.
- (3) Alterations or modifications that affect the unit's performance, operation, safety, durability, change its intended use, or cause failure of compliance with current regulatory standards or applicable federal, state or local laws.
- (4) Use of parts or accessories which are not recommended by Husqvarna Forest & Garden Company.
- (5) Additional damage to parts or components due to continued use occurring after any of the above.

**REPAIR OR REPLACEMENT AS PROVIDED UNDER THIS WARRANTY IS THE EXCLUSIVE REMEDY OF THE CONSUMER. HUSQVARNA SHALL NOT BE LIABLE FOR ANY INCIDENTAL OR CONSEQUENTIAL DAMAGES FOR BREACH OF ANY EXPRESS OR IMPLIED WARRANTY ON THESE PRODUCTS EXCEPT TO THE EXTENT PROHIBITED BY APPLICABLE LAW. ANY IMPLIED WARRANTY OF MERCHANTABILITY OR FITNESS FOR A PARTICULAR PURPOSE ON THESE PRODUCTS IS LIMITED IN DURATION TO THE WARRANTY PERIOD AS DEFINED IN THE LIMITED WARRANTY STATEMENT. HUSQVARNA RESERVES THE RIGHT TO CHANGE OR IMPROVE THE DESIGN OF THE PRODUCT WITHOUT NOTICE, AND DOES NOT ASSUME OBLIGATION TO UPDATE PREVIOUSLY MANUFACTURED PRODUCTS.**

Some states do not allow the exclusion of incidental or consequential damages, or limitations on how long an implied warranty lasts, so the above limitations or exclusions may not apply to you. This warranty gives you specific legal rights, and you may also have other rights which vary from state to state.

**SECTION 5: CUSTOMER RESPONSIBILITIES**

The customer must exhibit reasonable care, maintenance, operation, storage and general upkeep as written in the maintenance section of the Owner's/Operator's manual. Should an operational problem or failure occur the product should not be used, but delivered as is to an authorized Husqvarna dealer for evaluation. Proof of purchase, as explained in section 6, is solely with the customer.

**SECTION 6: PROCEDURE TO OBTAIN WARRANTY CONSIDERATION**

It is the Owner's and Dealer's responsibility to make certain that the Warranty Registration Card is properly filled out and mailed to Husqvarna Forest & Garden Company. This card should be mailed within ten (10) days from the date of purchase in order to validate the warranty and to provide post-sale service.

Proof of purchase must be presented to the authorized Husqvarna dealer in order to obtain warranty service. This receipt must include date purchased, model number, serial number, and complete name and address of the selling dealer.

To obtain the benefit of this warranty, the product believed to be defective must be delivered in a timely manner, within thirty (30) days from date of operational problem or failure, and during the warranty period, to any authorized Husqvarna dealer. The product must be delivered to the dealer, at the owner's expense. An authorized Husqvarna dealer can be normally located through the "Yellow Pages" of the local telephone directory.

**HUSQVARNA FOREST & GARDEN CO.  
9006-J PERIMETER WOODS DRIVE  
CHARLOTTE, NORTH CAROLINA 28216**

