

YTH180

Owner's Manual

142648



SAFETY RULES

Safe Operation Practices for Ride-On Mowers



IMPORTANT: THIS CUTTING MACHINE IS CAPABLE OF AMPUTATING HANDS AND FEET AND THROWING OBJECTS. FAILURE TO OBSERVE THE FOLLOWING SAFETY INSTRUCTIONS COULD RESULT IN SERIOUS INJURY OR DEATH.

I. GENERAL OPERATION

- Read, understand, and follow all instructions in the manual and on the machine before starting.
- Only allow responsible adults, who are familiar with the instructions, to operate the machine.
- Clear the area of objects such as rocks, toys, wire, etc., which could be picked up and thrown by the blade.
- Be sure the area is clear of other people before mowing. Stop machine if anyone enters the area.
- Never carry passengers.
- Do not mow in reverse unless absolutely necessary. Always look down and behind before and while backing.
- Be aware of the mower discharge direction and do not point it at anyone. Do not operate the mower without either the entire grass catcher or the guard in place.
- Slow down before turning.
- Never leave a running machine unattended. Always turn off blades, set parking brake, stop engine, and remove keys before dismounting.
- Turn off blades when not mowing.
- Stop engine before removing grass catcher or unclogging chute.
- Mow only in daylight or good artificial light.
- Do not operate the machine while under the influence of alcohol or drugs.
- Watch for traffic when operating near or crossing roadways.
- Use extra care when loading or unloading the machine into a trailer or truck.

II. SLOPE OPERATION

Slopes are a major factor related to loss-of-control and tipover accidents, which can result in severe injury or death. All slopes require extra caution. If you cannot back up the slope or if you feel uneasy on it, do not mow it.

DO:

- Mow up and down slopes, not across.
- Remove obstacles such as rocks, tree limbs, etc.
- Watch for holes, ruts, or bumps. Uneven terrain could overturn the machine. *Tall grass can hide obstacles.*
- Use slow speed. Choose a low gear so that you will not have to stop or shift while on the slope.
- Follow the manufacturer's recommendations for wheel weights or counterweights to improve stability.
- Use extra care with grass catchers or other attachments. These can change the stability of the machine.
- Keep all movement on the slopes *slow* and *gradual*. Do not make sudden changes in speed or direction.
- Avoid starting or stopping on a slope. If tires lose traction, disengage the blades and proceed slowly *straight* down the slope.

DO NOT:

- *Do not* turn on slopes unless necessary, and then, turn slowly and gradually downhill, if possible.
- *Do not* mow near drop-offs, ditches, or embankments. The mower could suddenly turn over if a wheel is over the edge of a cliff or ditch, or if an edge caves in.
- *Do not* mow on wet grass. Reduced traction could cause sliding.
- *Do not* try to stabilize the machine by putting your foot on the ground.
- *Do not* use grass catcher on steep slopes.

III. CHILDREN

Tragic accidents can occur if the operator is not alert to the presence of children. Children are often attracted to the machine and the mowing activity. *Never* assume that children will remain where you last saw them.

- Keep children out of the mowing area and under the watchful care of another responsible adult.
- Be alert and turn machine off if children enter the area.
- Before and when backing, look behind and *down* for small children.
- Never carry children. They may fall off and be seriously injured or interfere with safe machine operation.
- Never allow children to operate the machine.
- Use extra care when approaching blind corners, shrubs, trees, or other objects that may obscure vision.

IV. SERVICE

- Use extra care in handling gasoline and other fuels. They are flammable and vapors are explosive.
 - Use only an approved container.
 - Never remove gas cap or add fuel with the engine running. Allow engine to cool before refueling. Do not smoke.
 - Never refuel the machine indoors.
 - Never store the machine or fuel container inside where there is an open flame, such as a water heater.
- Never run a machine inside a closed area.
- Keep nuts and bolts, especially blade attachment bolts, tight and keep equipment in good condition.
- Never tamper with safety devices. Check their proper operation regularly.
- Keep machine free of grass, leaves, or other debris build-up. Clean oil or fuel spillage. Allow machine to cool before storing.
- Stop and inspect the equipment if you strike an object. Repair, if necessary, before restarting.
- Never make adjustments or repairs with the engine running.
- Grass catcher components are subject to wear, damage, and deterioration, which could expose moving parts or allow objects to be thrown. Frequently check components and replace with manufacturer's recommended parts, when necessary.
- Mower blades are sharp and can cut. Wrap the blade(s) or wear gloves, and use extra caution when servicing them.
- Check brake operation frequently. Adjust and service as required.



Look for this symbol to point out important safety precautions. It means CAUTION!!! BECOME ALERT!!! YOUR SAFETY IS INVOLVED.



CAUTION: Always disconnect spark plug wire and place wire where it cannot contact spark plug in order to prevent accidental starting when setting up, transporting, adjusting or making repairs.

CONGRATULATIONS on your purchase of a new tractor. It has been designed, engineered and manufactured to give you the best possible dependability and performance.

Should you experience any problem you cannot easily remedy, please contact your nearest authorized service center. We have competent, well-trained technicians and the proper tools to service or repair this tractor.

Please read and retain this manual. The instructions will enable you to assemble and maintain your tractor properly. Always observe the "SAFETY RULES".

MODEL NUMBER	YTH180
SERIAL NUMBER	_____
DATE OF PURCHASE	_____
THE MODEL AND SERIAL NUMBERS WILL BE FOUND ON A PLATE UNDER THE SEAT.	
YOU SHOULD RECORD BOTH SERIAL NUMBER AND DATE OF PURCHASE AND KEEP IN A SAFE PLACE FOR FUTURE REFERENCE.	

CUSTOMER RESPONSIBILITIES

- Read and observe the safety rules.
- Follow a regular schedule in maintaining, caring for and using your tractor.
- Follow the instructions under "Customer Responsibilities" and "Storage" sections of this manual.

PRODUCT SPECIFICATIONS

HORSEPOWER:	18.0
GASOLINE CAPACITY AND TYPE:	3.5 GALLONS UNLEADED REGULAR
OIL TYPE (API-SG):	SAE 30 (above 32°F) SAE 5W-30 (below 32°F)
OIL CAPACITY:	W/ FILTER: 4.0 PINTS W/O FILTER: 3.5 PINTS
SPARK PLUG: (GAP: .025")	CHAMPION RV17YC
VALVE CLEARANCE:	INTAKE: .003" - .006" EXHAUST: .013" - .016"
GROUND SPEED (MPH):	FORWARD: 5.4 REVERSE: 2.2
TIRE PRESSURE:	FRONT: 14 PSI REAR: 12 PSI
CHARGING SYSTEM:	15 AMPS @3600 RPM
BLADE BOLT TORQUE:	30-35 FT. LBS.

WARNING: This tractor is equipped with an internal combustion engine and should not be used on or near any unimproved forest-covered, brush-covered or grass-covered land unless the engine's exhaust system is equipped with a spark arrester meeting applicable local or state laws (if any). If a spark arrester is used, it should be maintained in effective working order by the operator.

A spark arrester for the muffler is available through your nearest authorized service center/department (See REPAIR PARTS section of this manual).

TABLE OF CONTENTS

SAFETY RULES	2
PRODUCT SPECIFICATIONS	3
CUSTOMER RESPONSIBILITIES	3, 15-18
ASSEMBLY	6-9
OPERATION	10-14
MAINTENANCE SCHEDULE	15

SERVICE AND ADJUSTMENTS	19-25
STORAGE	26
TROUBLESHOOTING	27-28
REPAIR PARTS - TRACTOR	30-47
WARRANTY	51

INDEX

A	
Adjustments:	
Brake	21
Carburetor	24
Clutch	21
Mower:	
Front-To-Back	20
Side-To-Side	20
Throttle Control Cable	24
Air Filter, Engine	18
Assembly	6-9
B	
Battery:	
Charging	7
Cleaning	17
Installation	8
Levels	7,17
Preparation	7
Starting with Weak Battery	23
Storage	26
Terminals	17
Belt:	
Motion Drive	
Removal/Replacement	22
Mower Blade Drive	
Removal/Replacement	21
Blade:	
Sharpening	16
Replacement	16
Brake Adjustment	21
C	
Carburetor Adjustment	24
Controls, Tractor	10
Customer Responsibilities	15-18
Engine:	
Air Filter	18
Air Screen	18
Battery	17
Engine Oil	17
Fuel Filter	18
Spark Plugs	18
Tractor:	
Blade	16
Lubrication Chart	15
Maintenance Schedule	15
Tire Care	7,16,23
Cutting Height, Mower	11

E	
Electrical:	
Interlocks and Relays	24
Schematic	29
Wiring Diagram	30
Engine:	
Air Filter	18
Air Screen	18
Cooling Fins	18
Oil Change	17
Oil Level	12,17
Oil Type	17
Preparation	12
Starting	13
Storage	26

F	
Filter:	
Air Filter	18
Fuel	18
Fuel:	
Type	13
Storage	26
Fuse	24

H	
Hood Removal/Installation	24

L	
Leveling Mower Deck	20
Lights:	
Indicator	13
Lubrication Chart	15

M	
Maintenance Schedule	15
Mower:	
Adjustment, Front-to-Back	20
Adjustment, Side-to-Side	20
Blade Sharpening	16
Blade Replacement	16
Cutting Height	11
Gauge Wheels	8
Installation	19
Mulcher Plate	9
Operation	12
Removal	19
Mowing Tips	14
Muffler	18

O	
Oil:	
Cold Weather Conditions	12,17
Engine	17
Storage	26
Operation	10-14
Operating Mower	12

P	
Parking Brake	10-11
Parts Bag	5
Parts, Replacement/Repair	30-47
Product Specifications	3

R	
Repair Parts	30-47

S	
Safety Rules	2
Seat	7
Service and Adjustments	19-25
Carburetor	24
Fuse	24
Hood Removal/Installation	24
Motion Drive Belt	
Removal/Replacement	22
Mower Blade Drive Belt	
Removal/Replacement	21
Mower Adjustment:	
Front-to-Back	20
Side-to-Side	20
Mower Removal	19
Tire Care	7,16,23
Slope Guide Sheet	50
Spark Plugs	18
Specifications	3
Starting the Engine	13
Steering Wheel	6,23
Stopping the Tractor	11
Storage	26

T	
Throttle Control Cable Adjustment	24
Tires	7,16,23
Transaxle	13,17
Transport	12
Trouble Shooting Chart	27-28

W	
Warranty	51
Wiring Diagram	30
Wiring Schematic	29

CONTENTS OF HARDWARE PACK

Parts Bag contents shown full size

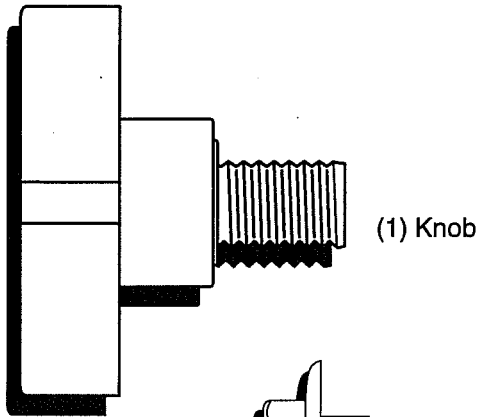

(1) Knob

(1) Shoulder Bolt
5/16-18

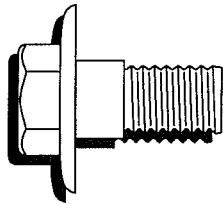

(1) Washer
17/32 x 1-3/16 x 12 Gauge

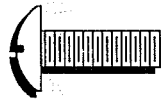
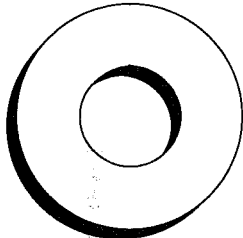

(2) Screws #10 x 5/8



(2) Lock Washers #10

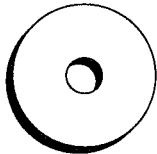

(2) Weld Nuts #10

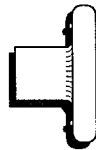

(2) Washers 3/16 x 3/4 x 16 Gauge



(2) Hex Bolts
1/4-20 x 3/4



(2) Washers
9/32 x 5/8 x 16 Gauge



(2) Hex Nuts 1/4-20

(2) Lock Washers 1/4



(2) Wing Nuts 1/4-20

Parts packed separately in carton

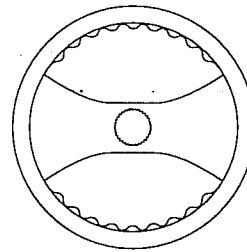

Steering Wheel

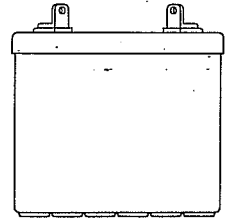

Battery



Mulcher Plate

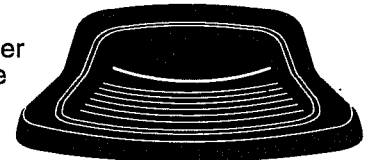

Seat

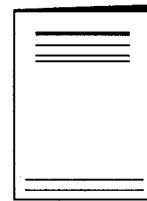

Owner's Manual

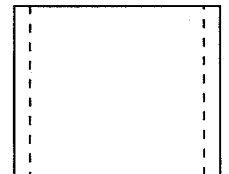

Parts Bag

Parts bag contents not shown full size

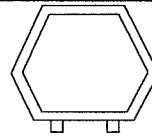

Steering Wheel Insert

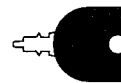

(2) Keys



(2) Gauge Wheels

(2) Shoulder Bolts



(2) Center Lock Nuts



Terminal Guard



(2) Washers
3/8 x 7/8 x 14 Gauge

(2) Battery Carriage Bolts 1/4-20 x 7-1/2

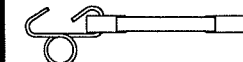

(2) Latch Hook Assemblies

(2) Washers
17/32 x 15/16 x 12 Gauge

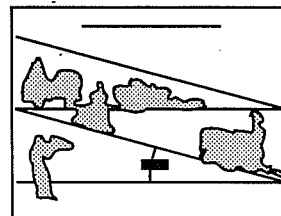

15° Slope Sheet

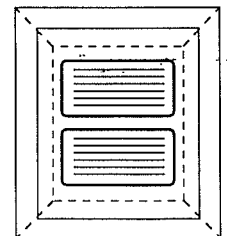

Battery Caps and Instructions

ASSEMBLY

Your new tractor has been assembled at the factory with exception of those parts left unassembled for shipping purposes. To ensure safe and proper operation of your tractor, all parts and hardware you assemble must be tightened securely. Use the correct tools as necessary to insure proper tightness.

TOOLS REQUIRED FOR ASSEMBLY

A socket wrench set will make assembly easier. Standard wrench sizes are listed.

- | | |
|---------------------------------|----------------------|
| (1) 3/4" socket w/drive ratchet | |
| (2) 7/16" wrenches | Phillips Screwdriver |
| (1) 1/2" wrench | Utility knife |
| (1) 9/16" wrench | Tire pressure gauge |

When right and left hand is mentioned in this manual, it means when you are in the operating position (seated behind the steering wheel).

TO REMOVE TRACTOR FROM CARTON

UNPACK CARTON

- Remove all accessible loose parts and parts cartons from carton (See page 5).
- Cut along lines on carton, from top to bottom, all four corners of carton and lay panels flat.
- Check for any additional loose parts or cartons and remove.

BEFORE ROLLING TRACTOR OFF SKID

ATTACH STEERING WHEEL (See Fig. 1)

- Remove locknut and large flat washer from steering shaft.
- Position front wheels of the tractor so they are pointing straight forward.
- Position steering wheel so cross bars are horizontal (left to right) and slide onto adapter.
- Secure steering wheel to steering shaft with locknut and large flat washer previously removed. Tighten securely.
- Snap steering wheel insert into center of steering wheel.
- Remove protective plastic from tractor hood and grill.

IMPORTANT: CHECK FOR AND REMOVE ANY STAPLES IN SKID THAT MAY PUNCTURE TIRES WHERE TRACTOR IS TO ROLL OFF SKID.

TO ROLL TRACTOR OFF SKID (See Fig. 9)

- Raise attachment lift lever to its highest position.
- Release parking brake by depressing clutch/brake pedal.
- Place freewheel control in freewheel position to disengage transmission (See "TO TRANSPORT" in Operation section of this manual).
- Roll tractor backwards off skid.
- Remove banding holding discharge guard up against tractor.

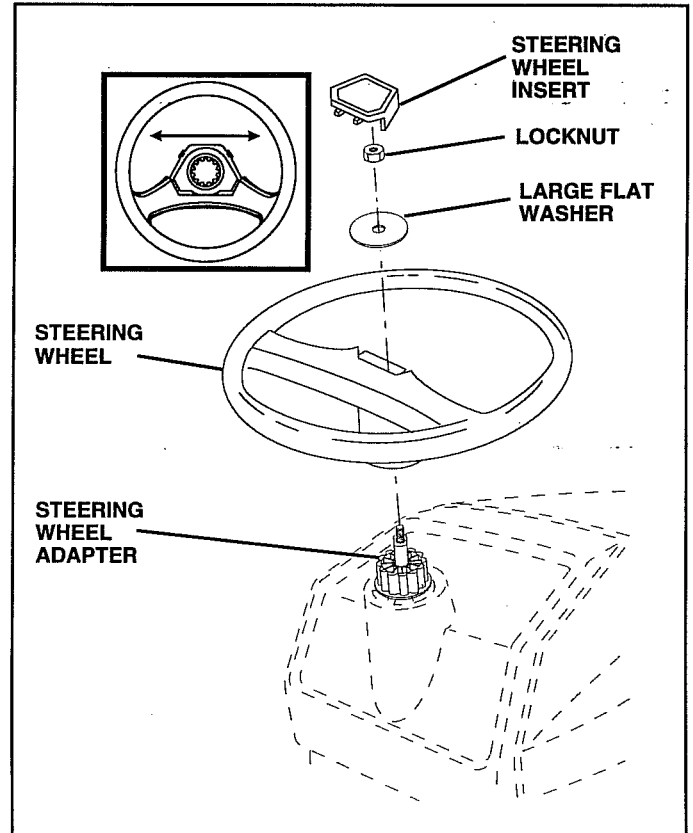

FIG. 1

ASSEMBLY

HOW TO SET UP YOUR TRACTOR

PREPARE BATTERY (See Fig. 2)



CAUTION: Wear eye and face shield. Wash hands or clothing immediately if accidentally in contact with battery acid. Do not smoke. Fumes from charged battery acid are explosive. Read the instructions included with the battery vent caps. Always wear gloves, clothing and goggles to protect your hands, skin and eyes.

Your tractor has a battery charging system which is sufficient for normal use. However, periodic charging of the battery with an automotive charger will extend its life.

- See instructions packed with vent caps in parts bag.
- Fill battery with acid. Fill each cell until it reaches the bottom of the vent wells. Do not overfill.
- Allow battery to stand and settle for at least thirty minutes. After standing, check the level of acid. If below the vent wells, add more acid until the correct level is reached.

While battery is standing (after adding acid) and later, while battery is being charged, continue with assembly of tractor.

IMPORTANT: TO MAXIMIZE THE LIFE OF YOUR BATTERY, IT IS NECESSARY THAT THE BATTERY BE CHARGED BEFORE USE. FAILURE TO CHARGE BATTERY CAN RESULT IN A SHORTENED BATTERY LIFE.

- Charge battery at a rate of 6 amperes for 1 hour. Use a 12 volt battery charger. Observe all safety precautions required for battery charging.
- Check the acid level after the battery is charged. If the acid has fallen below the correct level, add distilled or iron free water.
- Install the vent caps to cover the vent wells. Wash the top of the battery with water to remove any acid, then wipe dry.
- Check battery case for leakage to make sure that no damage has occurred in handling.
- Dispose of excess battery acid. Neutralize acid for disposal by adding it to 2 gallons of water in a five gallon plastic container. Stir with a wooden or plastic paddle while adding baking soda until the addition of more soda causes no more foaming.
- Follow instructions on how to install battery.

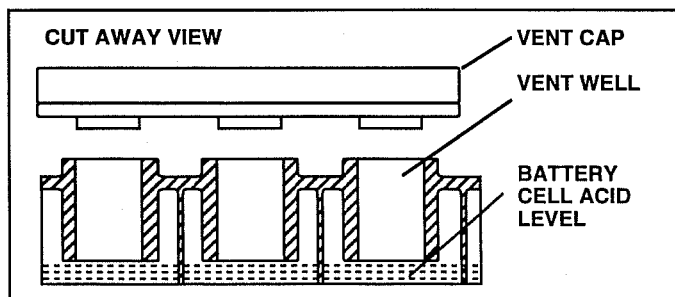

FIG. 2

INSTALL SEAT (See Fig. 3)

Adjust seat before tightening adjustment knob.

- Remove cardboard packing on seat pan.
- Place seat on pan and assemble shoulder bolt.
- Assemble adjustment knob and flat washer loosely. Do not tighten.
- Tighten shoulder bolt securely.
- Lower seat into operating position and sit on seat.
- Slide seat until a comfortable position is reached which allows you to press clutch/brake pedal all the way down.
- Get off seat without moving its adjusted position.
- Raise seat and tighten adjustment knob securely.

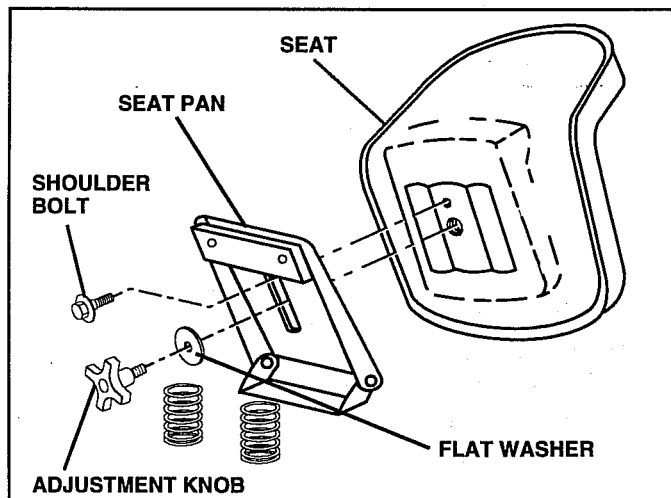

FIG. 3

CHECK TIRE PRESSURE

The tires on your tractor were overinflated at the factory for shipping purposes. Correct tire pressure is important for best cutting performance.

- Reduce tire pressure to PSI shown in "PRODUCT SPECIFICATIONS" on page 3 of this manual.

CHECK DECK LEVELNESS

For best cutting results, mower housing should be properly leveled. See "TO LEVEL MOWER HOUSING" in the Service and Adjustments section of this manual.

CHECK FOR PROPER POSITION OF ALL BELTS

See the figures that are shown for replacing motion and mower blade drive belts in the Service and Adjustments section of this manual. Verify that the belts are routed correctly.

CHECK BRAKE SYSTEM

After you learn how to operate your tractor, check to see that the brake is properly adjusted. See "TO ADJUST BRAKE" in the Service and Adjustments section of this manual.

ASSEMBLY

INSTALL BATTERY (See Figs. 4 & 5)



CAUTION: Do not short battery terminals. Before installing battery, remove metal bracelets, wristwatch bands, rings, etc.

Positive terminal must be connected first to prevent sparking from accidental grounding.

- Lift hood to raised position.
- Be sure battery drain tube has not come loose and is securely attached to drain in battery tray.
- Lower battery into battery tray with terminals to rear of tractor.
- First connect RED battery cable to positive (+) battery terminal with hex bolt, flat washer, lock washer and hex nut as shown. Tighten securely.
- Connect BLACK grounding cable to negative (-) battery terminal with remaining hex bolt, flat washer, lock washer and hex nut. Tighten securely.
- Slide the two battery bolts through the terminal guard and start the wing nuts onto the threads.
- Position terminal guard over the battery as shown, lower bolts into key holes and slide square shafts of bolts into slots of key holes.
- Tighten wing nuts by hand making sure battery bolts remain in slots of the key holes in the battery support.
- Be sure terminal access doors are closed.

Use terminal access doors for:

- Inspection for secure connections (to tighten hardware).
- Inspection for corrosion.
- Testing battery.
- Jumping (if required).
- Periodic charging.

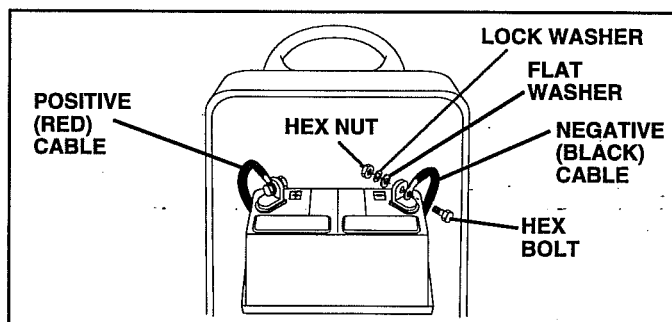

FIG. 4

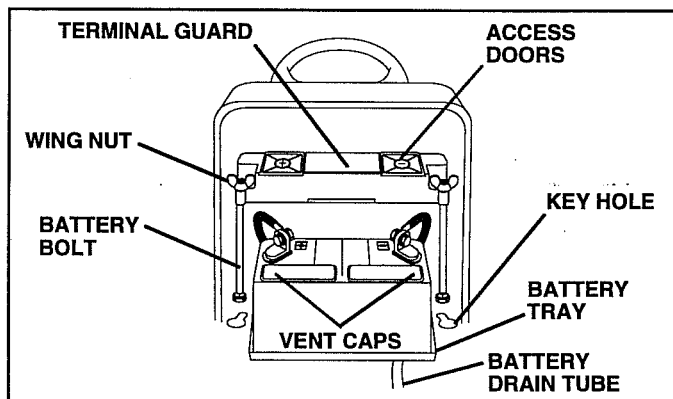

FIG. 5

ASSEMBLE GAUGE WHEELS TO MOWER DECK (See Fig. 6)

Assemble gauge wheels with tractor on a flat level surface.

- Adjust mower to desired cutting height (See "TO ADJUST MOWER CUTTING HEIGHT" in the Operation section of this manual).
- With mower in desired height of cut position, gauge wheels should be assembled so they are slightly off the ground. Install gauge wheel in appropriate hole with shoulder bolt, 17/32 washer, 3/8 washer, and 3/8-16 locknut and tighten securely.
- Repeat for opposite side installing gauge wheel in same adjustment hole.

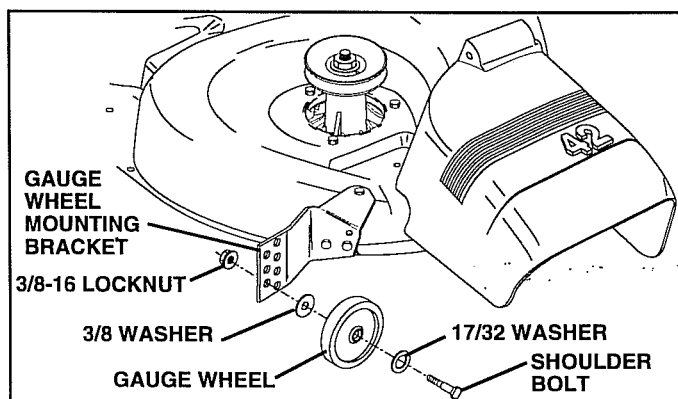

FIG. 6

ASSEMBLY

INSTALL MULCHER PLATE (See Figs. 7 & 8)

- Install two latch hooks to mulcher plate using screw, washer, lock washer, and weld nut as shown.

NOTE: Pre-assemble weld nut to latch hook by inserting weld nut from the top with hook pointing down.

- Tighten hardware securely.
- Raise and hold deflector shield in upright position.
- Place front of mulcher plate over front of mower deck opening and slide into place, as shown.
- Hook front latch into hole on front of mower deck.
- Hook rear latch into hole on back of mower deck.



CAUTION: Do not remove discharge guard from mower. Raise and hold guard when attaching mulcher plate and allow it to rest on plate while in operation.

TO CONVERT TO BAGGING OR DISCHARGING

Simply remove mulcher plate and store in a safe place. Your mower is now ready for discharging or installation of optional grass catcher accessory.

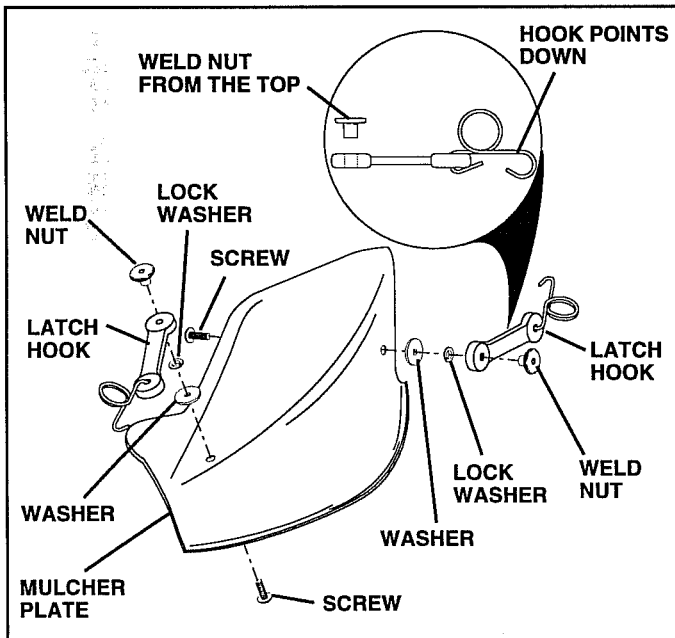

FIG. 7

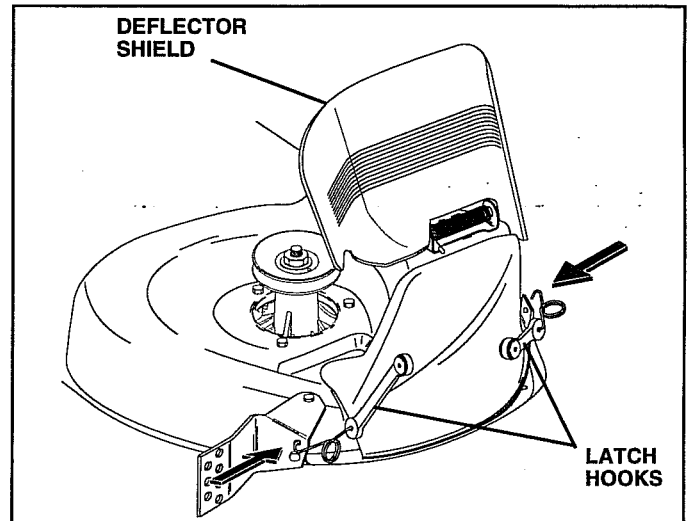

FIG. 8

✓ CHECKLIST

BEFORE YOU OPERATE AND ENJOY YOUR NEW TRACTOR, WE WISH TO ASSURE THAT YOU RECEIVE THE BEST PERFORMANCE AND SATISFACTION FROM THIS QUALITY PRODUCT.

PLEASE REVIEW THE FOLLOWING CHECKLIST:

- ✓ All assembly instructions have been completed.
- ✓ No remaining loose parts in carton.
- ✓ Battery is properly prepared and charged. (Minimum 1 hour at 6 amps).
- ✓ Seat is adjusted comfortably and tightened securely.
- ✓ All tires are properly inflated. (For shipping purposes, the tires were overinflated at the factory).
- ✓ Be sure mower deck is properly leveled side-to-side/front-to-rear for best cutting results. (Tires must be properly inflated for leveling).
- ✓ Check mower and drive belts. Be sure they are routed properly around pulleys and inside all belt keepers.
- ✓ Check wiring. See that all connections are still secure and wires are properly clamped.
- ✓ Before driving tractor, be sure freewheel control is in drive position.

WHILE LEARNING HOW TO USE YOUR TRACTOR, PAY EXTRA ATTENTION TO THE FOLLOWING IMPORTANT ITEMS:

- ✓ Engine oil is at proper level.
- ✓ Fuel tank is filled with fresh, clean, regular unleaded gasoline.
- ✓ Become familiar with all controls - their location and function. Operate them before you start the engine.
- ✓ Be sure brake system is in safe operating condition.
- ✓ It is important to purge the transmission before operating your tractor for the first time. Follow proper starting and transmission purging instructions (See "TO START ENGINE" and "PURGE TRANSMISSION" in Operation section of this manual).

OPERATION

KNOW YOUR TRACTOR

READ THIS OWNER'S MANUAL AND SAFETY RULES BEFORE OPERATING YOUR TRACTOR

Compare the illustrations with your tractor to familiarize yourself with the locations of various controls and adjustments. Save this manual for future reference.

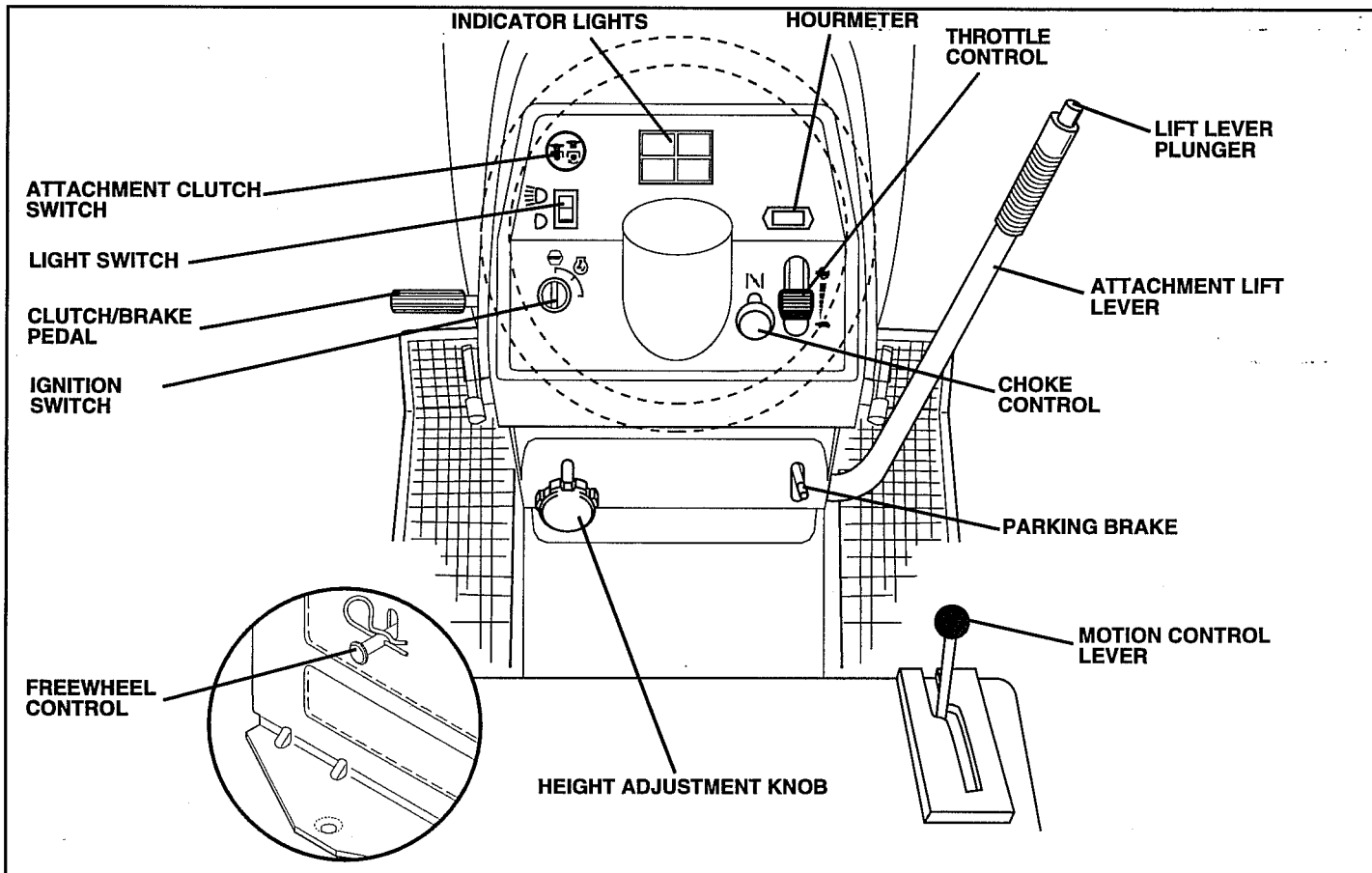

FIG. 9

Our tractors conform to the safety standards of the American National Standards Institute.

ATTACHMENT CLUTCH SWITCH: Used to engage the mower blades, or other attachments mounted to your tractor.

THROTTLE CONTROL - Used to control engine speed.

CHOKE CONTROL - Used when starting a cold engine.

CLUTCH/BRAKE PEDAL: Used for declutching and braking the tractor and starting the engine.

PARKING BRAKE: Locks clutch/brake pedal into the brake position.

HEIGHT ADJUSTMENT KNOB - Used to adjust the mower height.

MOTION CONTROL LEVER: Selects the speed and direction of tractor.

ATTACHMENT LIFT LEVER: Used to raise and lower the mower deck or other attachments mounted to your tractor.

LIFT LEVER PLUNGER: Used to release attachment lift lever when changing its position.

IGNITION SWITCH: Used for starting and stopping the engine.

INDICATOR LIGHTS - Indicates low fuel level, attachment engagement, low battery voltage, and low oil pressure.

HOURMETER - Indicates hours of operation.

LIGHT SWITCH: Turns the headlights on and off.

FREEWHEEL CONTROL: Disengages transmission for pushing or slowly towing the tractor with the engine off.

OPERATION

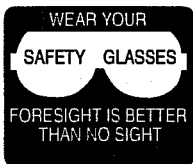

The operation of any tractor can result in foreign objects thrown into the eyes, which can result in severe eye damage. Always wear safety glasses or eye shields while operating your tractor or performing any adjustments or repairs. We recommend a wide vision safety mask for over the spectacles or standard safety glasses.

HOW TO USE YOUR TRACTOR TO SET PARKING BRAKE (See Fig. 10)

Your tractor is equipped with an operator presence sensing switch. When engine is running, any attempt by the operator to leave the seat without first setting the parking brake will shut off the engine.

- Depress clutch/brake pedal into full "BRAKE" position and hold.
- Place parking brake lever in "ENGAGED" position and release pressure from clutch/brake pedal. Pedal should remain in "BRAKE" position. Make sure parking brake will hold tractor secure.

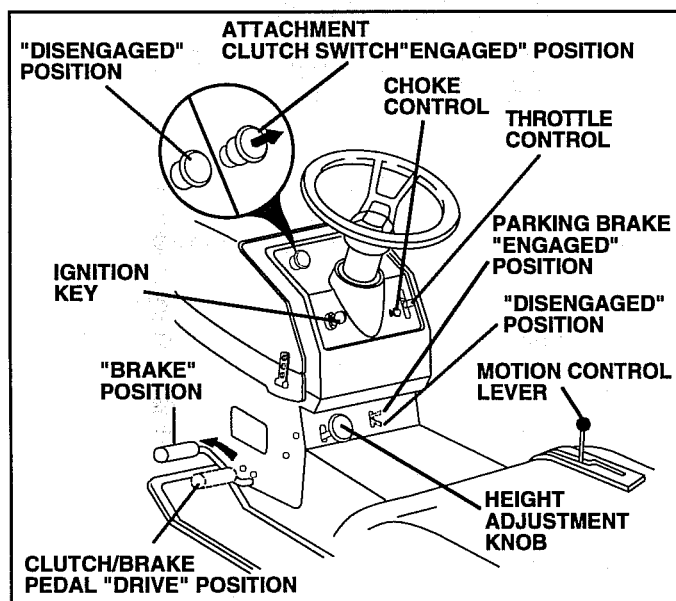

FIG. 10

STOPPING (See Fig. 10)

MOWER BLADES -

- Move attachment clutch switch to "DISENGAGED" position.

GROUND DRIVE -

- Depress clutch/brake pedal into full "BRAKE" position.
- Move motion control lever to neutral (N) position.

IMPORTANT: THE MOTION CONTROL LEVER DOES NOT RETURN TO NEUTRAL (N) POSITION WHEN THE CLUTCH/BRAKE PEDAL IS DEPRESSED.

ENGINE -

- Move throttle control to slow (☛) position.

NOTE: Failure to move throttle control to slow (☛) position and allowing engine to idle before stopping may cause engine to "backfire".

- Turn ignition key to "OFF" position and remove key. Always remove key when leaving tractor to prevent unauthorized use.
- Never use choke to stop engine.

NOTE: Under certain conditions when unit is standing idle with the engine running, hot engine exhaust gases may cause "browning" of grass. To eliminate this possibility, always stop engine when stopping tractor on grass areas.



CAUTION: Always stop tractor completely, as described above, before leaving the operator's position; to empty grass catcher, etc.

TO USE THROTTLE CONTROL (See Fig. 10)

Always operate engine at full throttle.

- Operating engine at less than full throttle reduces the battery charging rate.
- Full throttle offers the best bagging and mower performance.

TO USE CHOKE CONTROL (See Fig. 10)

Use choke control whenever you are starting a cold engine. Do not use to start a warm engine.

- To engage choke control, pull knob out. Slowly push knob in to disengage.

TO MOVE FORWARD AND BACKWARD (See Fig. 10)

The direction and speed of movement is controlled by the motion control lever.

- Start tractor with clutch/brake pedal depressed and motion control lever in neutral (N) position.
- Release parking brake and clutch/pedal.
- Slowly move motion control lever to desired position.

TO ADJUST MOWER CUTTING HEIGHT (See Fig. 10)

The cutting height is controlled by turning the height adjustment knob in desired direction.

- Turn knob clockwise (↻) to raise cutting height.
- Turn knob counterclockwise (↺) to lower cutting height.

The cutting height range is approximately 1-1/2" to 4". The heights are measured from the ground to the blade tip with the engine not running. These heights are approximate and may vary depending upon soil conditions, height of grass and types of grass being mowed.

- The average lawn should be cut to approximately 2-1/2 inches during the cool season and to over 3 inches during hot months. For healthier and better looking lawns, mow often and after moderate growth.
- For best cutting performance, grass over 6 inches in height should be mowed twice. Make the first cut relatively high; the second to desired height.

OPERATION

TO OPERATE MOWER (See Fig. 11)

Your tractor is equipped with an operator presence sensing switch. Any attempt by the operator to leave the seat with the engine running and the mower clutch engaged will shut off the engine.

- Select desired height of cut.
- Lower mower with attachment lift control.
- Start mower blades by engaging attachment clutch control.
- TO STOP MOWER BLADES - disengage attachment clutch control.



CAUTION: Do not operate the mower without either the entire grass catcher, on mowers so equipped, or the discharge guard in place.

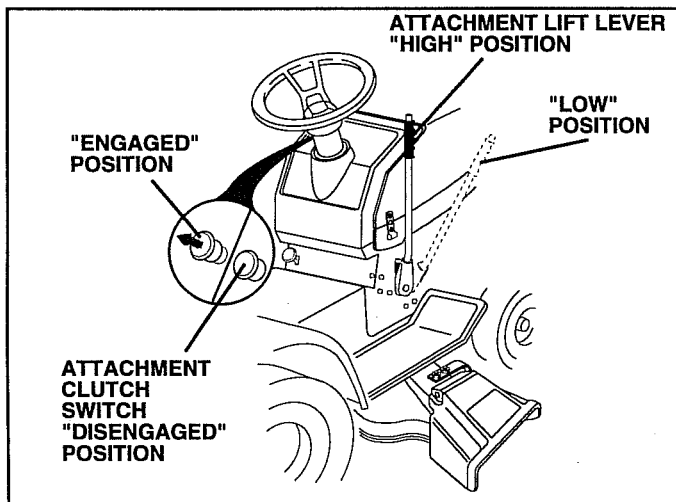

FIG. 11

TO OPERATE ON HILLS



CAUTION: Do not drive up or down hills with slopes greater than 15° and do not drive across any slope.

- Choose the slowest speed before starting up or down hills.
- Avoid stopping or changing speed on hills.
- If slowing is necessary, move throttle control lever to slower position.
- If stopping is absolutely necessary, push clutch/brake pedal quickly to brake position and engage parking brake.
- Move motion control lever to neutral (N) position.

IMPORTANT: THE MOTION CONTROL LEVER DOES NOT RETURN TO NEUTRAL (N) POSITION WHEN THE CLUTCH/BRAKE PEDAL IS DEPRESSED.

- To restart movement, slowly release parking brake and clutch/brake pedal.
- Slowly move motion control lever to slowest setting.
- Make all turns slowly.

TO TRANSPORT (See Figs. 9 & 12)

When pushing or towing your tractor, be sure to disengage transmission by placing freewheel control in freewheeling position. Free wheel control is located at the rear drawbar of tractor.

- Raise attachment lift to highest position with attachment lift control.
- Pull freewheel control knob out and hold in position by inserting retainer spring into forward hole of control rod.
- Do not push or tow tractor at more than two (2) MPH.
- To reengage transmission, reverse above procedure.

NOTE: To protect hood from damage when transporting your tractor on a truck or a trailer, be sure hood is closed and secured to tractor. Use an appropriate means of tying hood to tractor (rope, cord, etc.).

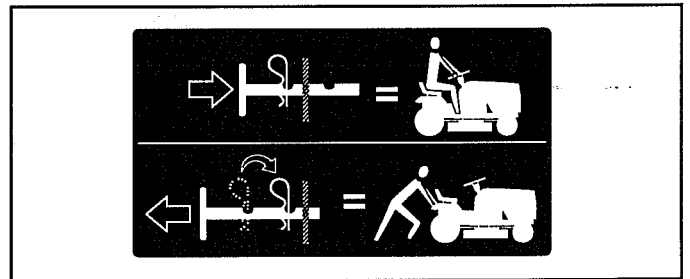

FIG. 12

BEFORE STARTING THE ENGINE

CHECK ENGINE OIL LEVEL (See Fig. 13)

- The engine in your tractor has been shipped, from the factory, already filled with summer weight oil.
- Check engine oil with tractor on level ground.
- Remove oil fill cap/dipstick and wipe clean, reinsert the dipstick and push it all the way down into the tube, wait for a few seconds, remove and read oil level. If necessary, add oil until "FULL" mark on dipstick is reached. Do not overfill.
- For cold weather operation you should change oil for easier starting (See "OIL VISCOSITY CHART" in the Customer Responsibilities section of this manual).
- To change engine oil, see the Customer Responsibilities section in this manual.

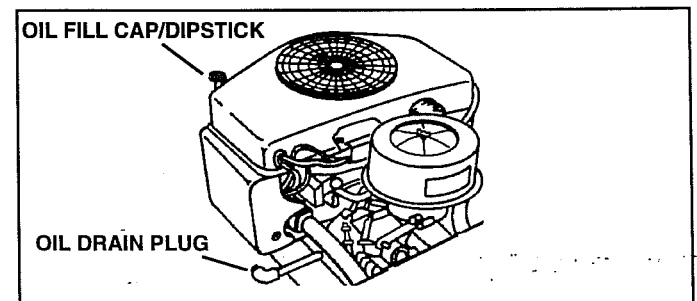

FIG. 13

ADD GASOLINE

- Fill fuel tank. Use fresh, clean, regular unleaded gasoline. (Use of leaded gasoline will increase carbon and lead oxide deposits and reduce valve life).

IMPORTANT: WHEN OPERATING IN TEMPERATURES BELOW 32°F(0°C), USE FRESH, CLEAN WINTER GRADE GASOLINE TO HELP INSURE GOOD COLD WEATHER STARTING.

OPERATION

WARNING: Experience indicates that alcohol blended fuels (called gasohol or using ethanol or methanol) can attract moisture which leads to separation and formation of acids during storage. Acidic gas can damage the fuel system of an engine while in storage. To avoid engine problems, the fuel system should be emptied before storage of 30 days or longer. Drain the gas tank, start the engine and let it run until the fuel lines and carburetor are empty. Use fresh fuel next season. See Storage Instructions for additional information. Never use engine or carburetor cleaner products in the fuel tank or permanent damage may occur.



CAUTION: Fill to bottom of gas tank filler neck. Do not overfill. Wipe off any spilled oil or fuel. Do not store, spill or use gasoline near an open flame.

INDICATOR LIGHTS

Located on the dash of your tractor, these lights alert you to necessary steps required to start your tractor or, while tractor is running, alerts you to a serious problem which requires immediate attention.



FUEL

- Indicates low level of gasoline in fuel tank. Fill tank with clean, fresh gasoline.



DISENGAGE ATTACHMENT

- Indicates you must disengage attachment clutch control to start tractor.



BATTERY DISCHARGING

- Indicates a drop in battery voltage. Increase throttle speed and/or check battery and wiring (See the Customer Responsibilities and Troubleshooting sections in this manual).



CHECK OIL

- Indicates low oil pressure in your engine. Light should come on when engine is not running and key switch is in "ON" position. This is a test to be sure light is working and a reminder to always check oil level before starting engine.

IMPORTANT: IF CHECK OIL LIGHT COMES ON WHILE THE ENGINE IS RUNNING, SHUT OFF ENGINE IMMEDIATELY AND CHECK FOR CAUSE OR SERIOUS ENGINE DAMAGE WILL OCCUR.

TO START ENGINE (See Fig. 10)

When starting engine for the first time or if engine has run out of fuel, it will take extra cranking time to move fuel from the tank to the engine.

- Depress clutch/brake pedal and set parking brake.
- Place motion control lever in neutral (N) position.
- Move attachment clutch to "DISENGAGED" position.
- Pull choke control out to choke (|X|) position for cold engine start. For warm engine start do not use choke control.
- Move throttle control to midway between fast (☛) and slow (☞) positions.
- Insert key into ignition and turn key clockwise to "START" position and release key as soon as engine starts. Do not run starter continuously for more than fifteen seconds per minute. If engine does not start after several attempts, move throttle control to fast (☛) position, wait a few minutes and try again.

- When engine starts, slowly push choke control in.
- Move throttle control to fast (☛) position.
- Allow engine to warm up for a few minutes before engaging drive or attachments.

IMPORTANT: COLD STARTING FOR HYDRO (BELOW 40°F) - AFTER STARTING ENGINE AND BEFORE DRIVING, LET TRANSMISSION WARM UP FOR ONE (1) MINUTE BY PLACING MOTION CONTROL LEVER IN NEUTRAL (N) POSITION AND RELEASING CLUTCH/ BRAKE PEDAL.

NOTE: If at a high altitude (above 3000 feet) or in cold temperatures (below 32°F), the carburetor fuel mixture may need to be adjusted for best engine performance. See "TO ADJUST CARBURETOR" in the Service and Adjustments section of this manual.

PURGE TRANSMISSION



CAUTION: Never engage or disengage freewheel lever while the engine is running.

To ensure proper operation and performance, it is recommended that the transmission be purged before operating tractor for the first time. This procedure will remove any trapped air inside the transmission which may have developed during shipping of your tractor.

IMPORTANT: SHOULD YOUR TRANSMISSION REQUIRE REMOVAL FOR SERVICE OR REPLACEMENT, IT SHOULD BE PURGED AFTER REINSTALLATION BEFORE OPERATING THE TRACTOR.

- Place tractor safely on level surface with engine off and parking brake set.
- Disengage transmission by placing freewheel control in freewheeling position (See "TO TRANSPORT" in this section of manual).
- Sitting in the tractor seat, start engine. After the engine is running, move throttle control to slow (☞) position. With motion control lever in neutral (N) position, slowly disengage clutch/brake pedal.
- Move motion control lever to full forward position and hold for five (5) seconds. Move lever to full reverse position and hold for five (5) seconds. Repeat this procedure three (3) times.

NOTE: During this procedure there will be no movement of drive wheels. The air is being removed from hydraulic drive system.

- Move motion control lever to neutral (N) position. Shut-off engine and set parking brake.
- Engage transmission by placing freewheel control in driving position (See "TO TRANSPORT" in this section of manual).
- Sitting in the tractor seat, start engine. After the engine is running, move throttle control to half (1/2) speed. With motion control lever in neutral (N) position, slowly disengage clutch/brake pedal.
- Slowly move motion control lever forward, after the tractor moves approximately five (5) feet, slowly move motion control lever to reverse position. After the tractor moves approximately five (5) feet return the motion control lever to the neutral (N) position. Repeat this procedure with the motion control lever three (3) times.
- Your tractor is now purged and now ready for normal operation.

OPERATION

MOWING TIPS

- Tire chains cannot be used when the mower housing is attached to tractor.
- Mower should be properly leveled for best mowing performance. See "TO LEVEL MOWER HOUSING" in the Service and Adjustments section of this manual.
- The left hand side of mower should be used for trimming.
- Drive so that clippings are discharged onto the area that has been cut. Have the cut area to the right of the machine. This will result in a more even distribution of clippings and more uniform cutting.
- When mowing large areas, start by turning to the right so that clippings will discharge away from shrubs, fences, driveways, etc. After one or two rounds, mow in the opposite direction making left hand turns until finished (See Fig. 14).
- If grass is extremely tall, it should be mowed twice to reduce load and possible fire hazard from dried clippings. Make first cut relatively high; the second to the desired height.
- Do not mow grass when it is wet. Wet grass will plug mower and leave undesirable clumps. Allow grass to dry before mowing.
- Always operate engine at full throttle when mowing to assure better mowing performance and proper discharge of material. Regulate ground speed by selecting a low enough gear to give the mower cutting performance as well as the quality of cut desired.
- When operating attachments, select a ground speed that will suit the terrain and give best performance of the attachment being used.

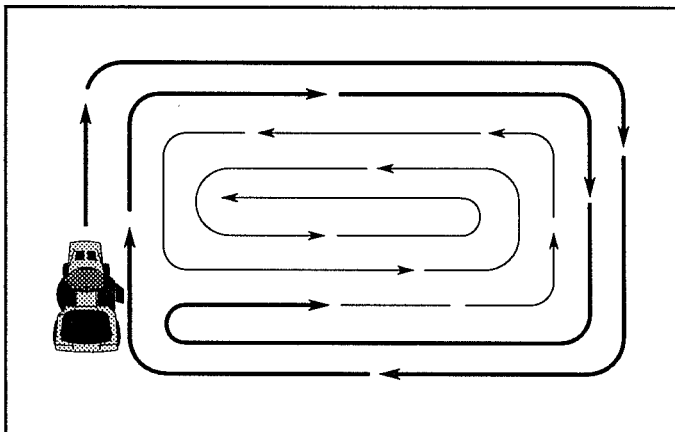

FIG. 14

MULCHING MOWING TIPS

IMPORTANT: FOR BEST PERFORMANCE, KEEP MOWER HOUSING FREE OF BUILT-UP GRASS AND TRASH. CLEAN AFTER EACH USE.

- The special mulching blade will recut the grass clippings many times and reduce them in size so that as they fall onto the lawn they will disperse into the grass and not be noticed. Also, the mulched grass will biodegrade quickly to provide nutrients for the lawn. Always mulch with your highest engine (blade) speed as this will provide the best recutting action of the blades.
- Avoid cutting your lawn when it is wet. Wet grass tends to form clumps and interferes with the mulching action. The best time to mow your lawn is the early afternoon. At this time the grass has dried and the newly cut area will not be exposed to the direct sun.
- For best results, adjust the mower cutting height so that the mower cuts off only the top one-third of the grass blades (See Fig. 15). For extremely heavy mulching, reduce your width of cut on each pass and mow slowly.

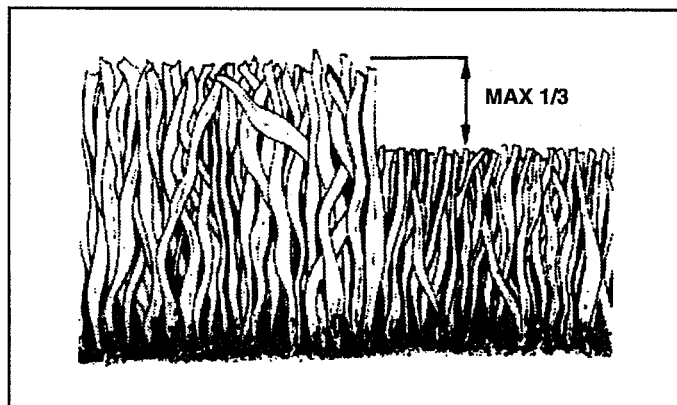

FIG. 15

- Certain types of grass and grass conditions may require that an area be mulched a second time to completely hide the clippings. When doing a second cut, mow across or perpendicular to the first cut path.
- Change your cutting pattern from week to week. Mow north to south one week then change to east to west the next week. This will help prevent matting and graining of the lawn.

CUSTOMER RESPONSIBILITIES

MAINTENANCE SCHEDULE FILL IN DATES AS YOU COMPLETE REGULAR SERVICE		SERVICE INTERVALS							SERVICE DATES				
		BEFORE EACH USE	FIRST 2 HOURS	EVERY 8 HOURS	EVERY 25 HOURS	EVERY 50 HOURS	EVERY 100 HOURS	EVERY SEASON	BEFORE STORAGE				
TRACTOR	Check Brake Operation	✓		✓									
	Check Tire Pressure	✓		✓									
	Check for Loose Fasteners	✓							✓				
	Sharpen/Replace Mower Blades				✓ ₄								
	Lubrication Chart				✓				✓				
	Check Battery Level/Recharge				✓								
	Clean Battery and Terminals				✓					✓			
	Check Transaxle Cooling				✓								
	Adjust Blade Belt(s) Tension							✓ ₅					
	Adjust Motion Drive Belt(s) Tension							✓ ₅					
ENGINE	Check Engine Oil Level	✓		✓									
	Change Engine Oil		✓		✓ _{1,2,3}				✓				
	Clean Air Filter				✓ ₂								
	Clean Air Screen				✓ ₂								
	Inspect Muffler/Spark Arrester					✓							
	Replace Oil Filter (If equipped)							✓ _{1,2}					
	Clean Engine Cooling Fins							✓ ₂					
	Replace Spark Plug							✓	✓				
	Replace Air Filter Paper Cartridge							✓ ₂					
	Replace Fuel Filter									✓			

1 - Change more often when operating under a heavy load or in high ambient temperatures.
2 - Service more often when operating in dirty or dusty conditions.

3 - If equipped with oil filter, change oil every 50 hours.
4 - Replace blades more often when mowing in sandy soil.
5 - If equipped with adjustable system.

GENERAL RECOMMENDATIONS

The warranty on this tractor does not cover items that have been subjected to operator abuse or negligence. To receive full value from the warranty, operator must maintain tractor as instructed in this manual.

Some adjustments will need to be made periodically to properly maintain your tractor.

All adjustments in the Service and Adjustments section of this manual should be checked at least once each season.

- Once a year you should replace the spark plug, clean or replace air filter, and check blades and belts for wear. A new spark plug and clean air filter assure proper air-fuel mixture and help your engine run better and last longer.

BEFORE EACH USE

- Check engine oil level.
- Check brake operation.
- Check tire pressure.
- Check for loose fasteners.

LUBRICATION CHART

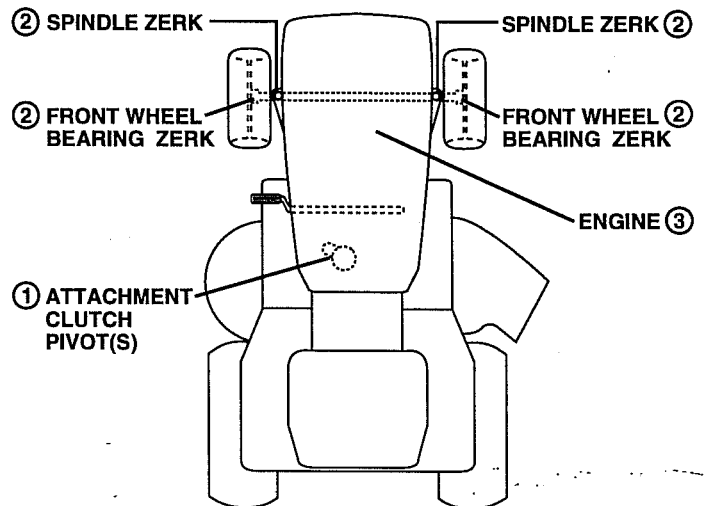

① SAE 30 OR 10W30 MOTOR OIL API - SG

② GENERAL PURPOSE GREASE

③ REFER TO CUSTOMER RESPONSIBILITIES "ENGINE" SECTION

IMPORTANT: DO NOT OIL OR GREASE THE PIVOT POINTS WHICH HAVE SPECIAL NYLON BEARINGS. VISCOUS LUBRICANTS WILL ATTRACT DUST AND DIRT THAT WILL SHORTEN THE LIFE OF THE SELF-LUBRICATING BEARINGS. IF YOU FEEL THEY MUST BE LUBRICATED, USE ONLY A DRY, POWDERED GRAPHITE TYPE LUBRICANT SPARINGLY.

CUSTOMER RESPONSIBILITIES

TRACTOR

Always observe safety rules when performing any maintenance.

BRAKE OPERATION

If tractor requires more than six (6) feet stopping distance at high speed in highest gear, then brake must be adjusted. (See "TO ADJUST BRAKE" in the Service and Adjustments section of this manual).

TIRES

- Maintain proper air pressure in all tires (See "PRODUCT SPECIFICATIONS" on page 3 of this manual).
- Keep tires free of gasoline, oil, or insect control chemicals which can harm rubber.
- Avoid stumps, stones, deep ruts, sharp objects and other hazards that may cause tire damage.

BLADE CARE

For best results mower blades must be kept sharp. Replace bent or damaged blades.

BLADE REMOVAL (See Fig. 16)

- Raise mower to highest position to allow access to blades.
- Remove hex bolt, lock washer and flat washer securing blade.
- Install new or resharpened blade with trailing edge up towards deck as shown.
- Reassemble hex bolt, lock washer and flat washer in exact order as shown.
- Tighten bolt securely (30-35 Ft. Lbs. torque).

IMPORTANT: BLADE BOLT IS GRADE 8 HEAT TREATED.

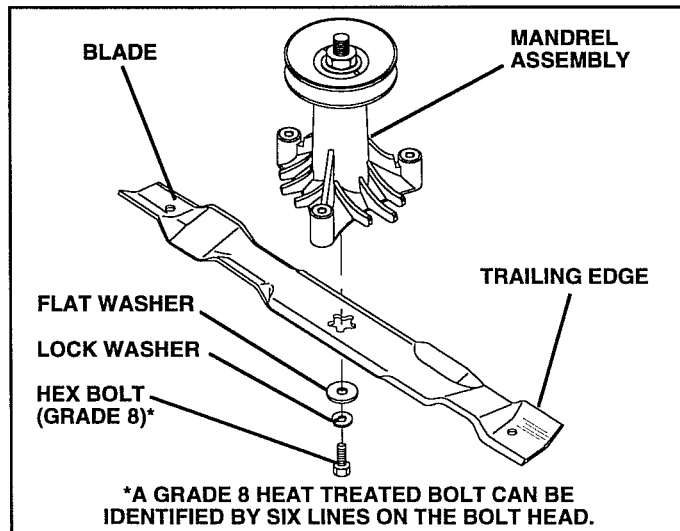

FIG. 16

TO SHARPEN BLADE (See Fig. 17)

Care should be taken to keep the blade balanced. An unbalanced blade will cause excessive vibration and eventual damage to mower and engine.

- The blade can be sharpened with a file or on a grinding wheel. Do not attempt to sharpen while on the mower.
- To check blade balance, you will need a 5/8" diameter steel bolt, pin, or a cone balancer. (When using a cone balancer, follow the instructions supplied with balancer).
- Slide blade on to an unthreaded portion of the steel bolt or pin and hold the bolt or pin parallel with the ground. If blade is balanced, it should remain in a horizontal position. If either end of the blade moves downward, sharpen the heavy end until the blade is balanced.

NOTE: Do not use a nail for balancing blade. The lobes of the center hole may appear to be centered, but are not.

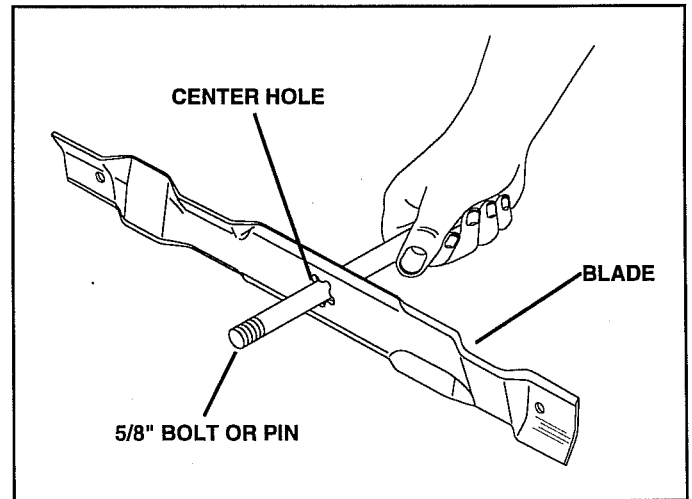

FIG. 17

CUSTOMER RESPONSIBILITIES

BATTERY (See Fig. 18)

Your tractor has a battery charging system which is sufficient for normal use. However, periodic charging of the battery with an automotive charger will extend its life.

- Acid solution level in each battery cell should be even with bottoms of vent wells. Add only distilled or iron free water if necessary. Do not overfill.
- Keep battery and terminals clean.
- Keep battery bolts tight.
- Keep vent caps tight and small vent holes in caps open.
- Recharge at 6 amperes for 1 hour.

TO CLEAN BATTERY AND TERMINALS -

Corrosion and dirt on the battery and terminals can cause the battery to "leak" power.

- Remove terminal guard.
- Disconnect BLACK battery cable first then RED battery cable and remove battery from tractor.
- Wash battery with solution of four tablespoons of baking soda to one gallon of water. Be careful not to get the soda solution into the cells.
- Rinse the battery with plain water and dry.
- Clean terminals and battery cable ends with wire brush until bright.
- Coat terminals with grease or petroleum jelly.
- Reinstall battery (See "INSTALL BATTERY" in the Assembly section of this manual).

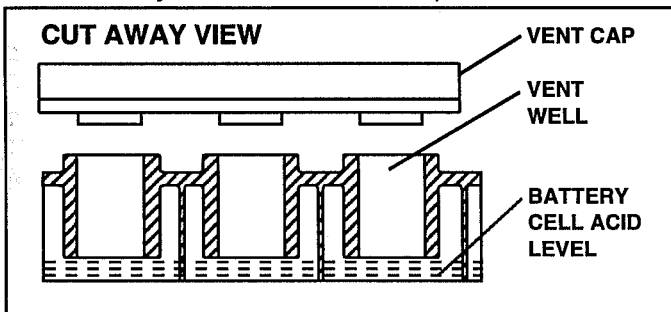

FIG. 18

V-BELTS

Check V-belts for deterioration and wear after 100 hours and replace if necessary. The belts are not adjustable. Replace belts if they begin to slip from wear.

TRANSAXLE COOLING

The fan and cooling fins of transmission should be kept clean to assure proper cooling.

Do not attempt to clean fan or transmission while engine is running or while the transmission is hot.

- Inspect cooling fan to be sure fan blades are intact and clean.
- Inspect cooling fins for dirt, grass clippings and other materials. To prevent damage to seals, do not use compressed air or high pressure sprayer to clean cooling fins.

TRANSAXLE PUMP FLUID

The transaxle was sealed at the factory and fluid maintenance is not required for the life of the transaxle. Should the transaxle ever leak or require servicing, contact your nearest authorized service center/department.

ENGINE

LUBRICATION

Only use high quality detergent oil rated with API service classification SG. Select the oil's SAE viscosity grade according to your expected operating temperature.

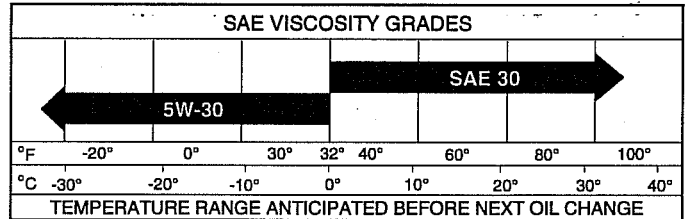

NOTE: Although multi-viscosity oils (5W30, 10W30 etc.) improve starting in cold weather, these multi-viscosity oils will result in increased oil consumption when used above 32°F. Check your engine oil level more frequently to avoid possible engine damage from running low on oil.

Change the oil after the first two hours of operation and every 50 hours thereafter or at least once a year if the tractor is not used for 50 hours in one year.

Check the crankcase oil level before starting the engine and after each eight (8) hours of continuous use. Tighten oil fill cap/dipstick securely each time you check the oil level.

TO CHANGE ENGINE OIL (See Fig. 19)

Determine temperature range expected before oil change. All oil must meet API service classification SG.

- Be sure tractor is on level surface.
- Oil will drain more freely when warm.
- Catch oil in a suitable container.
- Remove oil fill cap/dipstick. Be careful not to allow dirt to enter the engine when changing oil.
- Remove drain plug.
- After oil has drained completely, replace oil drain plug and tighten securely.
- Refill engine with oil through oil fill dipstick tube. Pour slowly. Do not overfill. For approximate capacity see "PRODUCT SPECIFICATIONS" on page 3 of this manual.
- Use gauge on oil fill cap/dipstick for checking level. Be sure dipstick is in all the way for accurate reading. Keep oil at "FULL" line on dipstick.

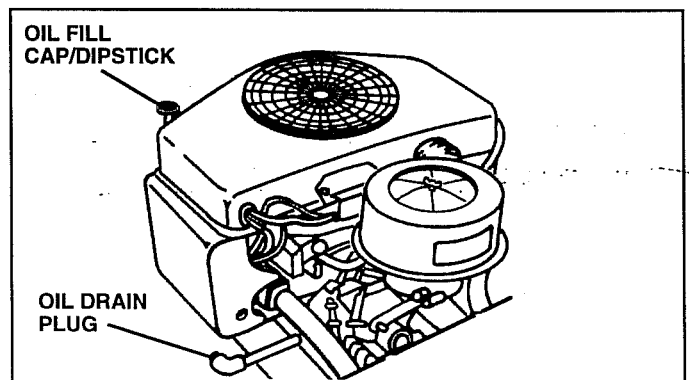

FIG. 19

CUSTOMER RESPONSIBILITIES

CLEAN AIR SCREEN (See Fig. 20)

Air screen must be kept free of dirt and chaff to prevent engine damage from overheating. Clean with a wire brush or compressed air to remove dirt and stubborn dried gum fibers.

ENGINE COOLING FINS (See Fig. 20)

Remove any dust, dirt or oil from engine cooling fins to prevent engine damage from overheating. Engine blower housing must be removed. Remove side panels and hood (See "TO REMOVE HOOD AND GRILL ASSEMBLY" in the Service and Adjustments section of this manual).

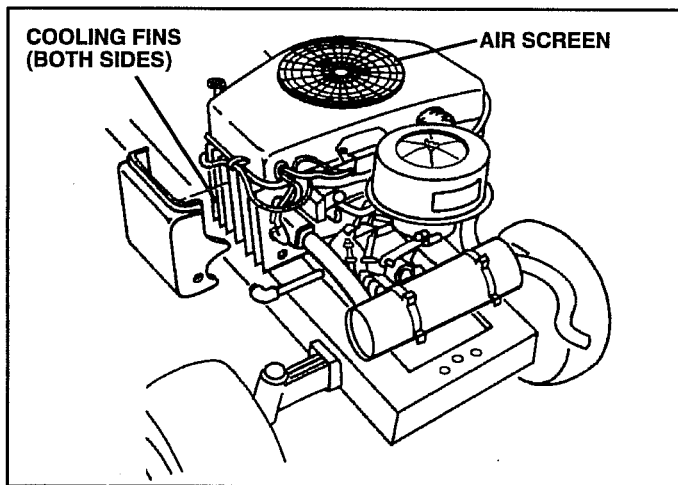

FIG. 20

AIR FILTER (See Fig. 21)

Your engine will not run properly using a dirty air filter. Clean the foam pre-cleaner after every 25 hours of operation or every season. Service paper cartridge every 100 hours of operation or every season, whichever occurs first.

Service air cleaner more often under dusty conditions.

- Remove wing nut and cover.
- Remove seal and cartridge plate.

TO SERVICE PRE-CLEANER

- Slide foam pre-cleaner off cartridge.
- Wash it in liquid detergent and water.
- Squeeze it dry in a clean cloth.
- Saturate it in engine oil. Wrap it in clean, absorbent cloth and squeeze to remove excess oil.

TO SERVICE CARTRIDGE

- Gently tap the flat side of the paper cartridge to dislodge dirt. Do not wash the paper cartridge or use pressurized air, as this will damage the cartridge. Replace a dirty, bent, or damaged cartridge.
- Reinstall the pre-cleaner (cleaned and oiled) over the paper cartridge.
- Reassemble air cleaner, cartridge plate, and seal.
- Install the air cleaner cover and wing nut. Tighten wing nut 1/2 turn to 1 full turn after nut contacts cover. Do not overtighten.

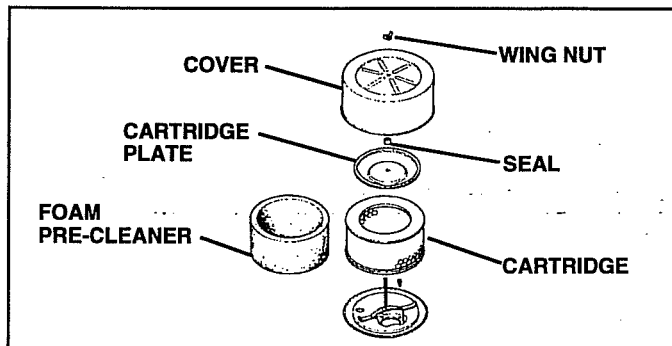

FIG. 21

ENGINE OIL FILTER

Replace the engine oil filter every season or every other oil change if the tractor is used more than 100 hours in one year.

MUFFLER

Inspect and replace corroded muffler and spark arrester (if equipped) as it could create a fire hazard and/or damage.

SPARK PLUGS

Replace spark plugs at the beginning of each mowing season or after every 100 hours of operation, whichever comes first. Spark plug type and gap setting are shown in "PRODUCT SPECIFICATIONS" on page 3 of this manual.

IN-LINE FUEL FILTER (See Fig. 22)

The fuel filter should be replaced once each season. If fuel filter becomes clogged, obstructing fuel flow to carburetor, replacement is required.

- With engine cool, remove filter and plug fuel line sections.
- Place new fuel filter in position in fuel line.
- Be sure there are no fuel line leaks and clamps are properly positioned.
- Immediately wipe up any spilled gasoline.

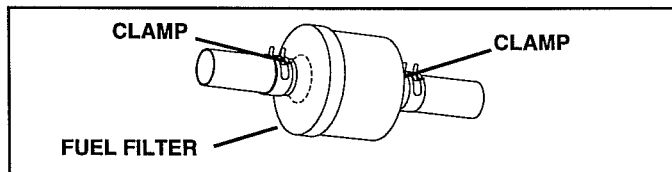

FIG. 22

CLEANING

IMPORTANT: FOR BEST PERFORMANCE, KEEP MOWER HOUSING FREE OF BUILD-UP, GRASS AND TRASH. CLEAN UNDERSIDE OF MOWER HOUSING AFTER EACH USE.

- Clean engine, battery, seat, finish, etc. of all foreign matter.
- Keep finished surfaces and wheels free of all gasoline, oil, etc.
- Protect painted surfaces with automotive type wax.

We do not recommend using a garden hose to clean your tractor unless the electrical system, muffler, air filter and carburetor are covered to keep water out. Water in engine can result in a shortened engine life.

SERVICE AND ADJUSTMENTS



CAUTION: BEFORE PERFORMING ANY SERVICE OR ADJUSTMENTS:

- Depress clutch/brake pedal fully and set parking brake.
- Place motion control lever in neutral (N) position.
- Place attachment clutch in "DISENGAGED" position.
- Turn ignition key "OFF" and remove key.
- Make sure the blades and all moving parts have completely stopped.
- Disconnect spark plug wire from spark plug and place wire where it cannot come in contact with plug.

TO REMOVE MOWER (See Fig. 23)

Mower will be easier to remove from the right side of tractor.

- Place attachment clutch switch in "DISENGAGED" position.
- Move attachment lift lever forward to lower mower to its lowest position.
- Roll belt off electric clutch pulley.
- Disconnect anti-sway bar from chassis bracket by removing retainer spring.
- Disconnect suspension arms from rear deck brackets by removing retainer springs.
- Disconnect front links from deck by removing retainer springs.
- Raise lift lever to raise suspension arms. Slide mower out from under tractor.

IMPORTANT: IF AN ATTACHMENT OTHER THAN THE MOWER IS TO BE MOUNTED TO THE TRACTOR, THE R.H. AND L.H. SUSPENSION ARMS MUST BE REMOVED FROM TRACTOR.

TO INSTALL MOWER (See Fig. 23)

- Raise attachment lift lever to its highest position.
- Slide mower under tractor with discharge guard to right side of tractor.
- Lower lift lever to its lowest position.
- Install mower in reverse order of removal instructions.

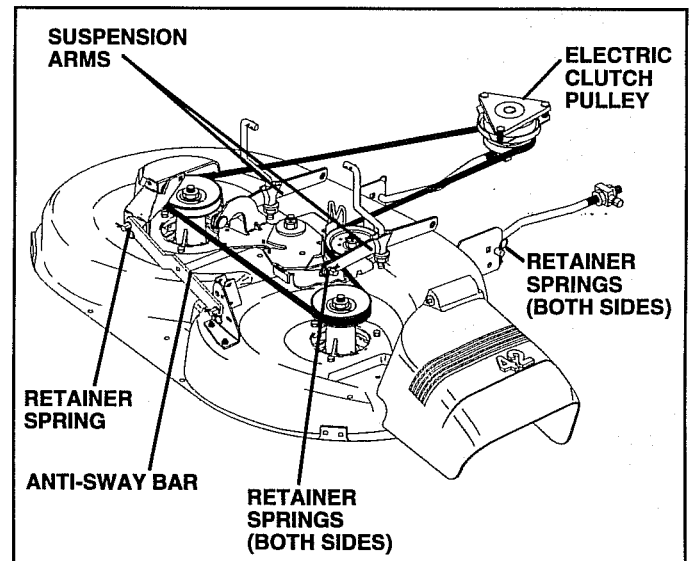

FIG. 23

SERVICE AND ADJUSTMENTS

TO LEVEL MOWER HOUSING

Adjust the mower while tractor is parked on level ground or driveway. Make sure tires are properly inflated (See "PRODUCT SPECIFICATIONS" on page 3 of this manual). If tires are over or underinflated, you will not properly adjust your mower.

SIDE-TO-SIDE ADJUSTMENT (See Figs. 24 and 25)

- Raise mower to its highest position.
- At the midpoint of both sides of mower, measure height from bottom edge of mower to ground. Distance "A" on both sides of mower should be the same or within 1/4" of each other.
- If adjustment is necessary, make adjustment on one side of mower only.
- To raise one side of mower, tighten lift link adjustment nut on that side.
- To lower one side of mower, loosen lift link adjustment nut on that side.

NOTE: Three full turns of adjustment nut will change mower height about 1/8".

- Recheck measurements after adjusting.

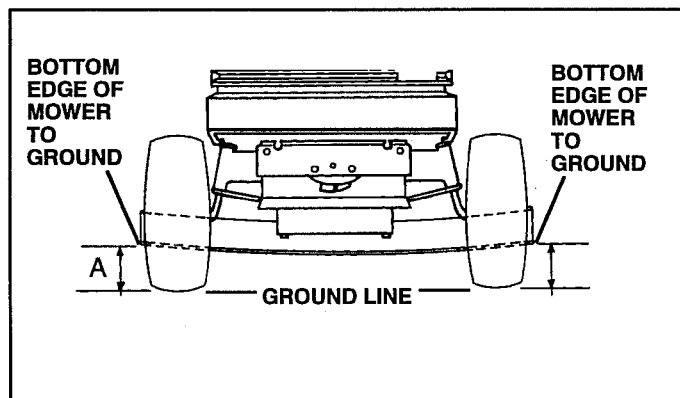

FIG. 24

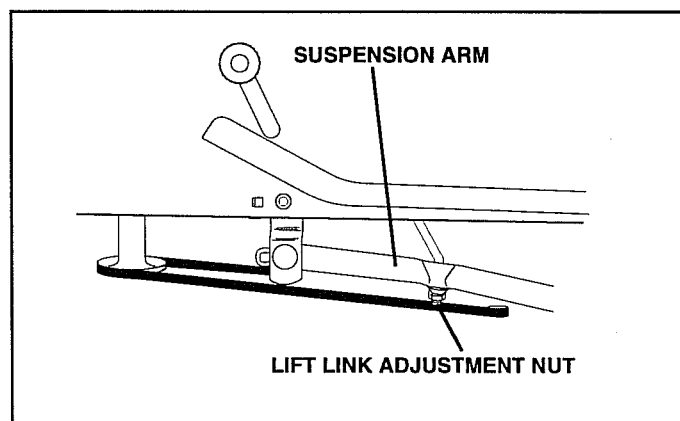

FIG. 25

FRONT-TO-BACK ADJUSTMENT (See Figs. 26 and 27)

IMPORTANT: DECK MUST BE LEVEL SIDE-TO-SIDE. IF THE FOLLOWING FRONT-TO-BACK ADJUSTMENT IS NECESSARY, BE SURE TO ADJUST BOTH FRONT LINKS EQUALLY SO MOWER WILL STAY LEVEL SIDE-TO-SIDE.

To obtain the best cutting results, the mower housing should be adjusted so that the front is approximately 1/4" to 3/4" lower than the rear when the mower is in its highest position.

Check adjustment on right side of tractor. Measure distance "D" directly in front and behind the mandrel at bottom edge of mower housing as shown.

- Before making any necessary adjustments, check that both front links are equal in length. Both links should be approximately 10-3/8".
- If links are not equal in length, adjust one link to same length as other link.
- To lower front of mower loosen nut "E" on both front links an equal number of turns.
- When distance "D" is 1/4" to 3/4" lower at front than rear, tighten nuts "F" against trunnion on both front links.
- To raise front of mower, loosen nut "F" from trunnion on both front links. Tighten nut "E" on both front links an equal number of turns.
- When distance "D" is 1/4" to 3/4" lower at front than rear, tighten nut "F" against trunnion on both front links.
- Recheck side-to-side adjustment.

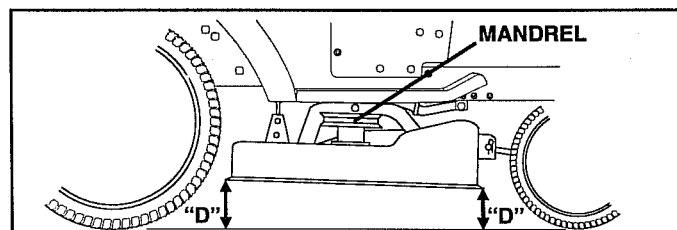

FIG. 26

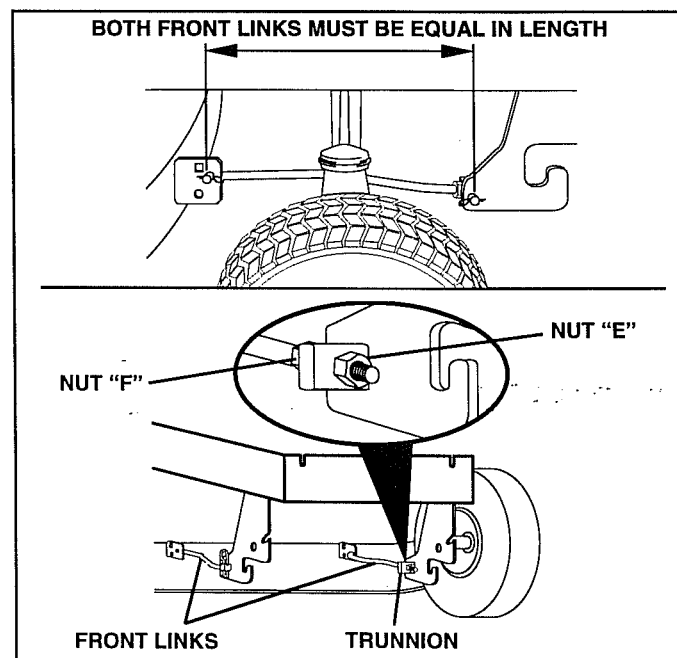

FIG. 27

SERVICE AND ADJUSTMENTS

TO REPLACE MOWER BLADE DRIVE BELT (See Fig. 28)

The mower blade drive belt may be replaced without tools. Park the tractor on level surface. Engage parking brake. For assistance, there is a belt installation guide decal on the mower housing.

BELT REMOVAL -

- Remove mower from tractor (See "TO REMOVE MOWER" in this section of this manual).
- Work belt off both mandrel pulleys and idler pulley.
- Pull belt away from mower.

BELT INSTALLATION -

- Install new belt in reverse order of removal.
- Make sure belt is in all pulley grooves and inside all belt guides.

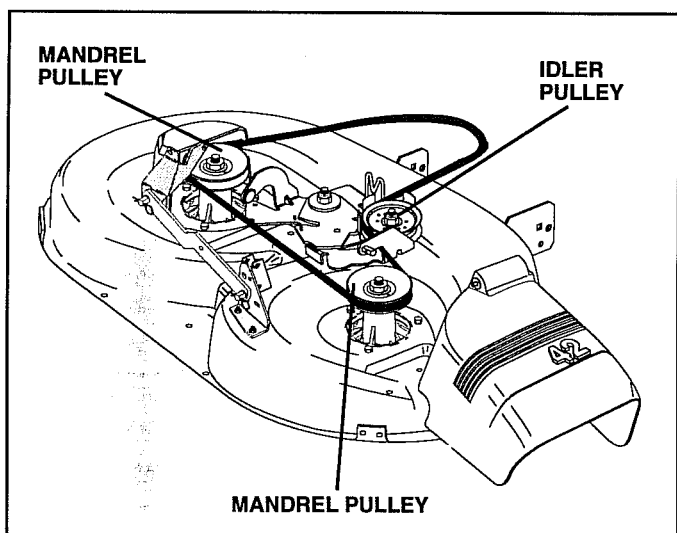

FIG. 28

TO ADJUST ATTACHMENT CLUTCH (See Fig. 29)

The electric clutch should provide years of service. The clutch has a built-in brake that stops the pulley within 5 seconds. Eventually, the internal brake will wear which may cause the mower blades to not engage, or, to not stop as required. Adjustments should be made by an authorized service technician.

- Make sure attachment clutch and ignition switches are in "OFF" position.
- Adjust the three nylon locknuts until space between clutch plate and rotor measures .012" at all three slot locations cut in the side of brake plate.

NOTE: After installing a new electric clutch, run tractor at full throttle and engage and disengage electric clutch 10 cycles to wear in clutch plate.

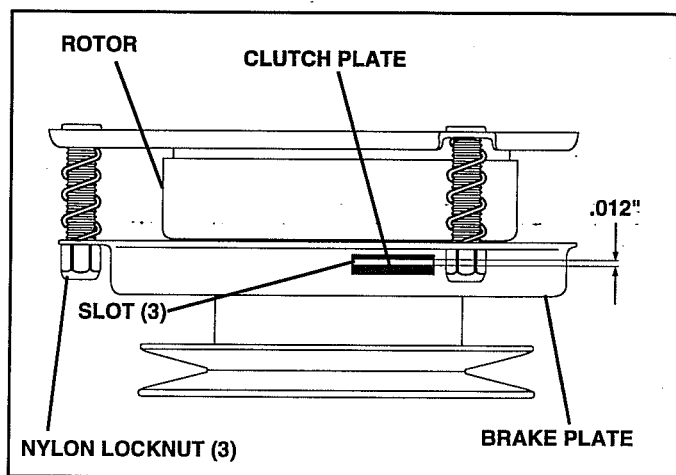

FIG. 29

TO ADJUST BRAKE (See Fig. 30)

Your tractor is equipped with an adjustable brake system which is mounted on the right side of the transaxle.

If tractor requires more than six (6) feet stopping distance at high speed in highest gear, then brake must be adjusted.

- Depress clutch/brake pedal and engage parking brake.
- Measure distance between brake operating arm and nut "A" on brake rod.
- If distance is other than 1-3/4", loosen jam nut and turn nut "A" until distance becomes 1-3/4". Retighten jam nut against nut "A".
- Road test tractor for proper stopping distance as stated above. Readjust if necessary. If stopping distance is still greater than six (6) feet in highest gear, further maintenance is necessary. Contact your nearest authorized service center.

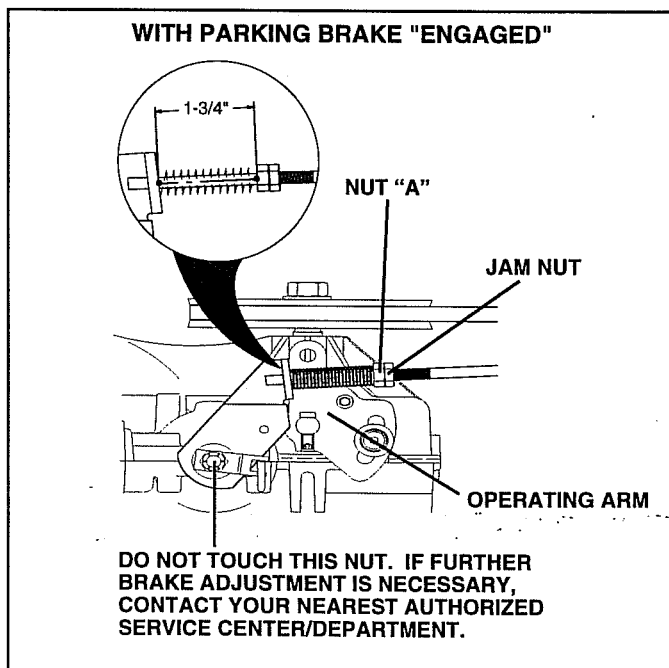

FIG. 30

SERVICE AND ADJUSTMENTS

TO REPLACE MOTION DRIVE BELT (See Fig. 31)

Park the tractor on level surface. Engage parking brake. For assistance, there is a belt installation guide decal on bottom side of left footrest.

- Remove mower (See "TO REMOVE MOWER" in this section of this manual.)
- Disconnect clutch wire harness.
- Remove clutch locator.
- Remove upper belt keeper.
- Remove belt from stationary idler and clutching idler.
- Pull belt slack toward rear of tractor. Carefully remove belt upwards from transmission input pulley and over cooling fan blades.
- Pull belt toward front of tractor and remove downwards from around electric clutch.
- Install new belt by reversing above procedure.

IMPORTANT: MAKE SURE UPPER BELT KEEPER IS POSITIONED PROPERLY BETWEEN LOCATOR TABS AND ELECTRIC CLUTCH WIRE CONNECTION IS SECURE.

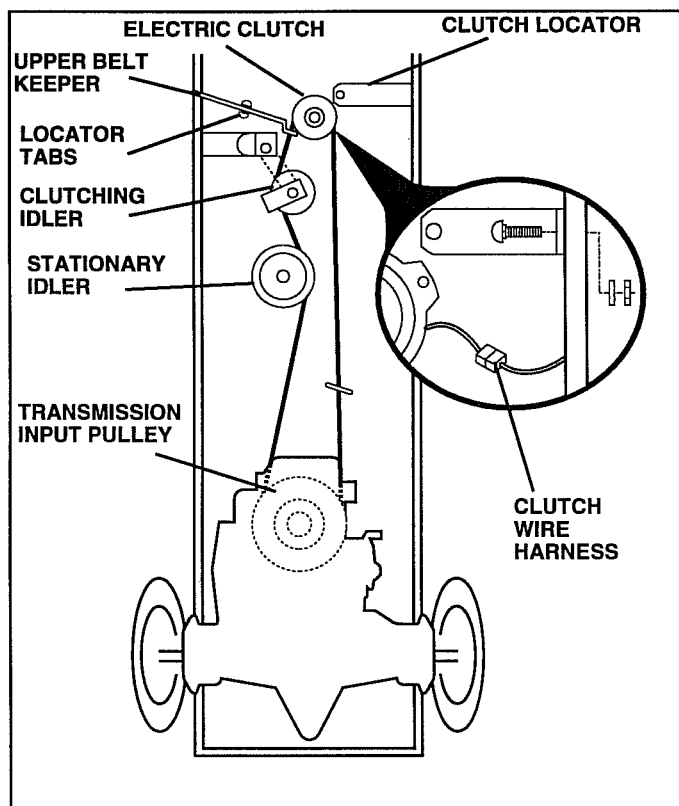

FIG. 31

TO ADJUST MOTION CONTROL LEVER (See Fig. 32)

The motion control lever has been preset at the factory and adjustment should not be necessary.

If for any reason the motion control lever will not hold its position while at a selected speed, it may be adjusted at the friction pack located on the right side of transmission.

- Park tractor on level surface. Stop tractor by turning ignition key to "OFF" position, and engage parking brake.
- Adjust motion control lever by tightening adjustment locknut one half (1/2) turn.

NOTE: If for any reason the effort to move the motion control lever becomes too excessive, reverse the above adjustment procedure by loosening locknut 1/4 to 1/2 turn.

Road test tractor after adjustment and repeat procedure if necessary.

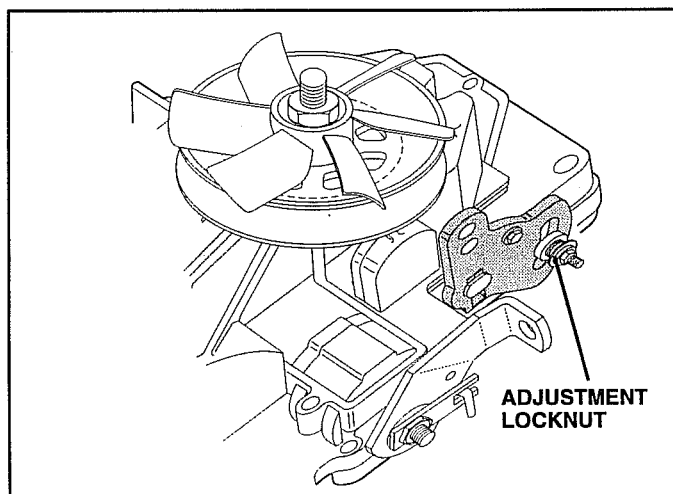

FIG. 32

TRANSMISSION REMOVAL/REPLACEMENT

Should your transmission require removal for service or replacement, it should be purged after reinstallation before operating the tractor. See "PURGE TRANSMISSION" in Operation section of this manual.

SERVICE AND ADJUSTMENTS

TO ADJUST STEERING WHEEL ALIGNMENT

If steering wheel crossbars are not horizontal (left to right) when wheels are positioned straight forward, remove steering wheel and reassemble per instructions in the Assembly section of this manual.

FRONT WHEEL TOE-IN/CAMBER

The front wheel toe-in and camber are not adjustable on your tractor. If damage has occurred to affect the front wheel toe-in or camber, contact your nearest authorized service center.

TO REMOVE WHEEL FOR REPAIRS (See Fig. 33)

- Block up axle securely.
- Remove wheel cover, retaining ring and washers to allow wheel removal (rear wheel contains a square key - Do not lose).
- Repair tire and reassemble.
- On rear wheels only: align grooves in rear wheel hub and axle. Insert square key.
- Replace washers and snap retaining ring securely in axle groove.
- Replace wheel cover.

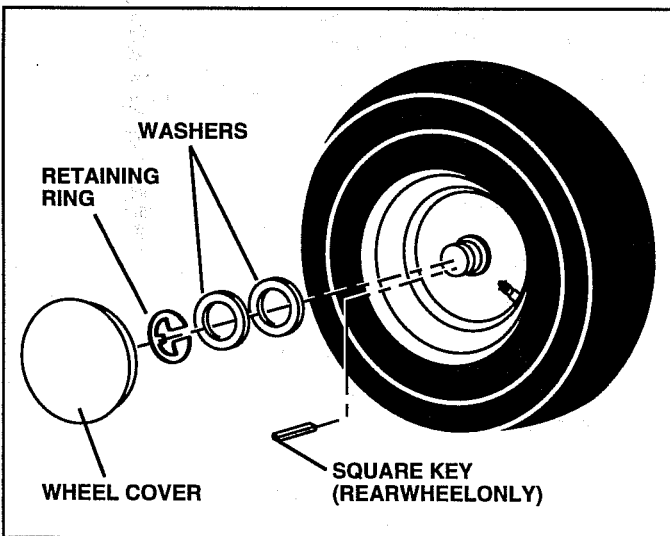

FIG. 33

TO START ENGINE WITH A WEAK BATTERY (See Fig. 34)



CAUTION: Lead-acid batteries generate explosive gases. Keep sparks, flame and smoking materials away from batteries. Always wear eye protection when around batteries.

If your battery is too weak to start the engine, it should be recharged. If "jumper cables" are used for emergency starting, follow this procedure:

IMPORTANT: YOUR TRACTOR IS EQUIPPED WITH A 12 VOLT NEGATIVE GROUNDED SYSTEM. THE OTHER VEHICLE MUST ALSO BE A 12 VOLT NEGATIVE GROUNDED SYSTEM. DO NOT USE YOUR TRACTOR BATTERY TO START OTHER VEHICLES.

TO ATTACH JUMPER CABLES -

- Connect each end of the RED cable to the POSITIVE (+) terminal of each battery, taking care not to short against chassis.
- Connect one end of the BLACK cable to the NEGATIVE (-) terminal of fully charged battery.
- Connect the other end of the BLACK cable to a good CHASSIS GROUND, away from fuel tank and battery.

TO REMOVE CABLES, REVERSE ORDER -

- BLACK cable first from chassis and then from the fully charged battery.
- RED cable last from both batteries.

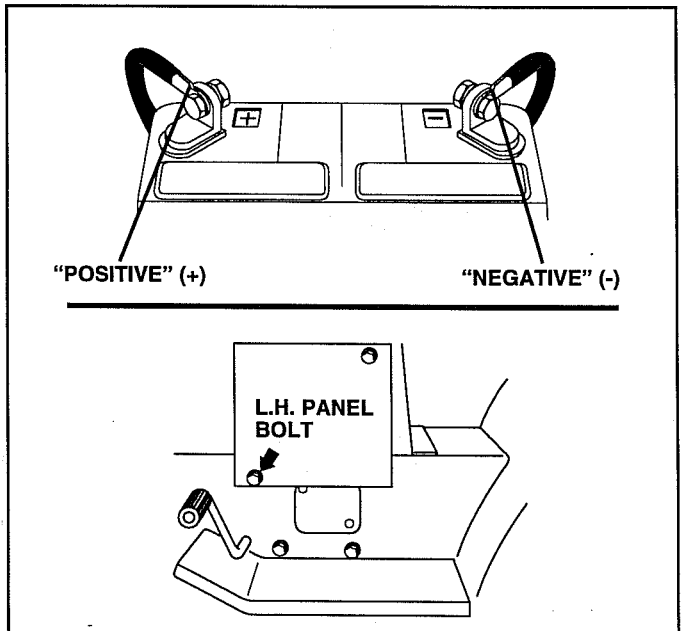

FIG. 34

SERVICE AND ADJUSTMENTS

TO REPLACE FUSE

Replace with 30 amp automotive-type plug-in fuse. The fuse holder is located in the engine compartment, directly in front of the dash.

TO REPLACE HEADLIGHT BULB

- Raise hood.
- Pull bulb holder out of the hole in the backside of the grill.
- Replace bulb in holder and push bulb holder securely back into the hole in the backside of the grill.
- Close hood.

INTERLOCKS AND RELAYS

Loose or damaged wiring may cause your tractor to run poorly, stop running or prevent it from starting.

- Check wiring. See the electrical wiring diagram in the Repair Parts section of this manual.

TO REMOVE HOOD AND GRILL ASSEMBLY (See Fig. 35)

- Lift hood. Disconnect headlight wiring connection.
- Remove wingnut at rear of each side panel.
- Remove retainer springs from hood pivot brackets.
- Pivot hood and side panel forward and lift off tractor.
- To replace, reverse above procedure.

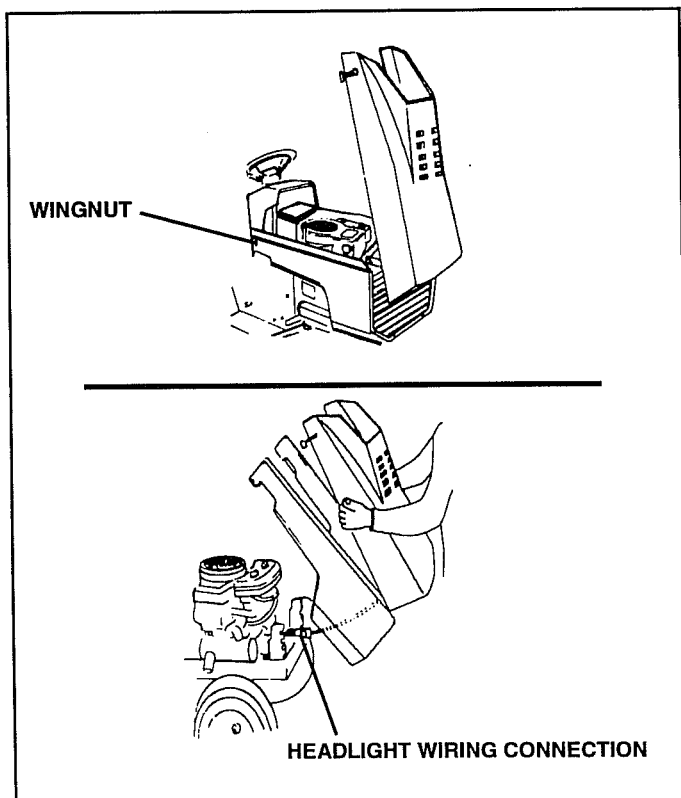

FIG. 35

ENGINE

TO ADJUST THROTTLE CONTROL CABLE (See Figs. 36,37 & 38)

The throttle control has been preset at the factory and adjustment should not be necessary. Check adjustment as described below before loosening cable. If adjustment is necessary, proceed as follows:

- With engine not running, move throttle control lever to fast (☛) position.
- Check that speed control lever is against stop screw. If it is not, loosen casing clamp screw and pull throttle cable until lever is against screw. Tighten clamp screw securely.

TO ADJUST CARBURETOR (See Figs. 36,37 & 38)

The carburetor has been present at the factory and adjustment should not be necessary. However, minor adjustment may be required to compensate for differences in fuel, temperature, altitude or load. If the carburetor does need adjustment, proceed as follows:

In general, turning the adjusting needles **in** (clockwise) decreases the supply of fuel to the engine giving a leaner fuel/air mixture. Turning the adjusting needles **out** (counterclockwise) increases the supply of fuel to the engine giving a richer fuel/air mixture.

IMPORTANT: DAMAGE TO THE NEEDLES AND THE SEATS IN CARBURETOR MAY RESULT IF SCREW IS TURNED IN TOO TIGHT.

PRELIMINARY SETTING -

- Be sure you have a clean air filter, and the throttle control cable is adjusted properly (see above).
- With engine off turn idle fuel adjusting needle **in** (clockwise) closing it finger tight and then turn **out** (counterclockwise) 1-1/4 turns.
- Turn main fuel adjusting needle **in** (clockwise) closing finger tight and then turn **out** (counterclockwise) 1 turn.

FINAL SETTING -

- Start engine and allow to warm for five minutes. Make final adjustments with engine running and shift/motion control lever in neutral (N) position.
- With throttle control lever in fast (☛) position, turn main fuel adjusting needle **in** (clockwise) until engine begins to die then turn **out** (counterclockwise) until engine runs rough. Turn needle to a point midway between those two positions.
- Idle speed setting - With throttle control lever in slow (☛) position, engine should idle at 1400 RPM. If engine idles too slow or fast, turn idle speed adjusting screw in or out until correct idle is attained.
- Idle fuel needle setting - With throttle control lever in slow (☛) position, turn idle fuel adjusting needle **in** (clockwise) until engine begins to die and then turn **out** (counterclockwise) until engine runs rough. Turn needle to a point midway between those two positions.
- Recheck idle speed. Readjust if necessary.

SERVICE AND ADJUSTMENTS

ACCELERATION TEST -

- Move throttle control lever from slow (←) to fast (→) position. If engine hesitates or dies, turn idle mixture screw out (counterclockwise) 1/8 turn. Repeat test and continue to adjust, if necessary, until engine accelerates smoothly.

High speed stop is factory adjusted. Do not adjust-damage may result.

IMPORTANT: NEVER TAMPER WITH THE ENGINE GOVERNOR, WHICH IS FACTORY SET FOR PROPER ENGINE SPEED. OVERSPEEDING THE ENGINE ABOVE THE FACTORY HIGH SPEED SETTING CAN BE DANGEROUS. IF YOU THINK THE ENGINE-GOVERNED HIGH SPEED NEEDS ADJUSTING, CONTACT YOUR NEAREST AUTHORIZED SERVICE CENTER/DEPARTMENT, WHICH HAS PROPER EQUIPMENT AND EXPERIENCE TO MAKE ANY NECESSARY ADJUSTMENTS.

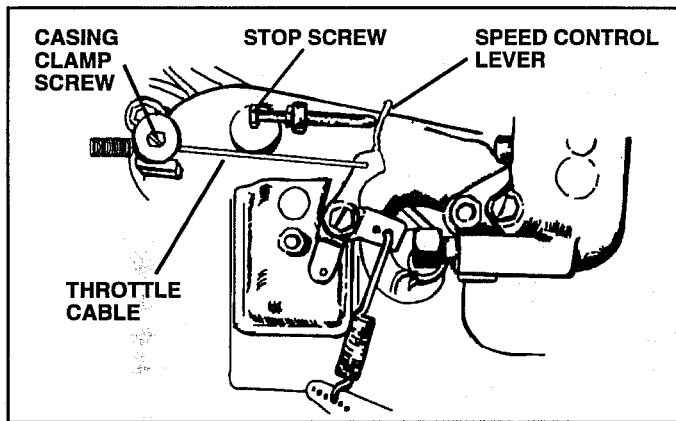

FIG. 36

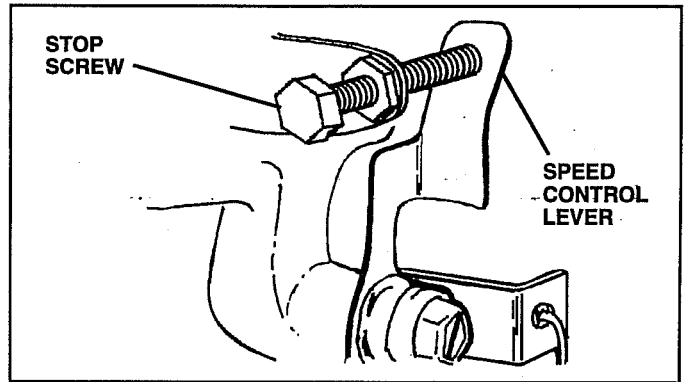

FIG. 37

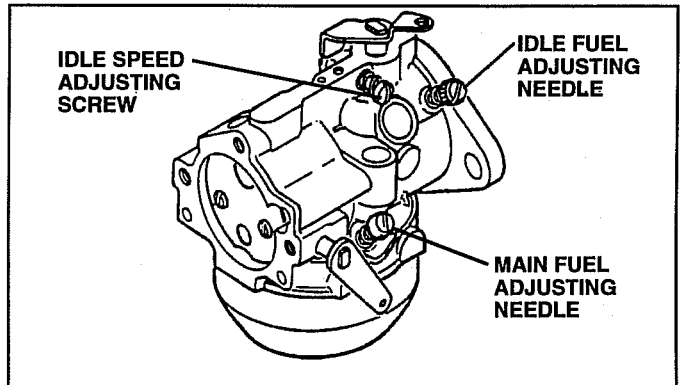

FIG. 38

STORAGE

Immediately prepare your tractor for storage at the end of the season or if the tractor will not be used for 30 days or more.



CAUTION: Never store the tractor with gasoline in the tank inside a building where fumes may reach an open flame or spark. Allow the engine to cool before storing in any enclosure.

TRACTOR

Remove mower from tractor for winter storage. When mower is to be stored for a period of time, clean it thoroughly, remove all dirt, grease, leaves, etc. Store in a clean, dry area.

- Clean entire tractor (See "CLEANING" in the Customer Responsibilities section of this manual).
- Inspect and replace belts, if necessary (See belt replacement instructions in the Service and Adjustments section of this manual).
- Lubricate as shown in the Customer Responsibilities section of this manual.
- Be sure that all nuts, bolts and screws are securely fastened. Inspect moving parts for damage, breakage and wear. Replace if necessary.
- Touch up all rusted or chipped paint surfaces; sand lightly before painting.

BATTERY

- Fully charge the battery for storage.
- After a period of time in storage, battery may require recharging.
- To help prevent corrosion and power leakage during long periods of storage, battery cables should be disconnected and battery cleaned thoroughly (see "TO CLEAN BATTERY AND TERMINALS" in the Customer Responsibilities section of this manual).
- After cleaning, leave cables disconnected and place cables where they cannot come in contact with battery terminals.
- Be sure battery drain tube is securely attached.
- If battery is removed from tractor for storage, do not store battery directly on concrete or damp surfaces.

ENGINE

FUEL SYSTEM

IMPORTANT: IT IS IMPORTANT TO PREVENT GUM DEPOSITS FROM FORMING IN ESSENTIAL FUEL SYSTEM PARTS SUCH AS CARBURETOR, FUEL FILTER, FUEL HOSE, OR TANK DURING STORAGE. ALSO, EXPERIENCE INDICATES THAT ALCOHOL BLENDED FUELS (CALLED GASOHOL OR USING ETHANOL OR METHANOL) CAN ATTRACT MOISTURE WHICH LEADS TO SEPARATION AND FORMATION OF ACIDS DURING STORAGE. ACIDIC GAS CAN DAMAGE THE FUEL SYSTEM OF AN ENGINE WHILE IN STORAGE.

- Drain the fuel tank.
- Start the engine and let it run until the fuel lines and carburetor are empty.
- Never use engine or carburetor cleaner products in the fuel tank or permanent damage may occur.
- Use fresh fuel next season.

NOTE: Fuel stabilizer is an acceptable alternative in minimizing the formation of fuel gum deposits during storage. Add stabilizer to gasoline in fuel tank or storage container. Always follow the mix ratio found on stabilizer container. Run engine at least 10 minutes after adding stabilizer to allow the stabilizer to reach the carburetor. Do not drain the gas tank and carburetor if using fuel stabilizer.

ENGINE OIL

Drain oil (with engine warm) and replace with clean engine oil. (See "ENGINE" in the Customer Responsibilities section of this manual).

CYLINDERS

- Remove spark plug(s).
- Pour one ounce of oil through spark plug hole(s) into cylinder(s).
- Turn ignition key to "START" position for a few seconds to distribute oil.
- Replace with new spark plug(s).

OTHER

- Do not store gasoline from one season to another.
- Replace your gasoline can if your can starts to rust. Rust and/or dirt in your gasoline will cause problems.
- If possible, store your tractor indoors and cover it to give protection from dust and dirt.
- Cover your tractor with a suitable protective cover that does not retain moisture. Do not use plastic. Plastic cannot breathe which allows condensation to form and will cause your tractor to rust.

IMPORTANT: NEVER COVER TRACTOR WHILE ENGINE AND EXHAUST AREAS ARE STILL WARM.

TROUBLESHOOTING POINTS

PROBLEM	CAUSE	CORRECTION
Will not start	<ol style="list-style-type: none"> 1. Out of fuel. 2. Engine not "CHOKED" properly. 3. Engine flooded. 4. Bad spark plug. 5. Dirty air filter. 6. Dirty fuel filter. 7. Water in fuel. 8. Loose or damaged wiring. 9. Carburetor out of adjustment. 10. Engine valves out of adjustment. 	<ol style="list-style-type: none"> 1. Fill fuel tank. 2. See "TO START ENGINE" in Operation section. 3. Wait several minutes before attempting to start. 4. Replace spark plug. 5. Clean/replace air filter. 6. Replace fuel filter. 7. Drain fuel tank and carburetor, refill tank with fresh gasoline and replace fuel filter. 8. Check all wiring. 9. Contact an authorized service center/department. 10. Contact an authorized service center/department.
Hard to start	<ol style="list-style-type: none"> 1. Dirty air filter. 2. Bad spark plug. 3. Weak or dead battery. 4. Dirty fuel filter. 5. Stale or dirty fuel. 6. Loose or damaged wiring. 7. Carburetor out of adjustment. 8. Engine valves out of adjustment. 	<ol style="list-style-type: none"> 1. Clean/replace air filter. 2. Replace spark plug. 3. Recharge or replace battery. 4. Replace fuel filter. 5. Drain fuel tank and refill with fresh gasoline. 6. Check all wiring. 7. Contact an authorized service center/department. 8. Contact an authorized service center/department.
Engine will not turn over	<ol style="list-style-type: none"> 1. Clutch/brake pedal not depressed. 2. Attachment clutch is engaged. 3. Weak or dead battery. 4. Blown fuse. 5. Corroded battery terminals. 6. Loose or damaged wiring. 7. Faulty ignition switch. 8. Faulty solenoid or starter. 9. Faulty operator presence switch(es). 	<ol style="list-style-type: none"> 1. Depress clutch/brake pedal. 2. Disengage attachment clutch. 3. Recharge or replace battery. 4. Replace fuse. 5. Clean battery terminals. 6. Check all wiring. 7. Check/replace ignition switch. 8. Check/replace solenoid or starter. 9. Contact an authorized service center/department.
Engine clicks but will not start	<ol style="list-style-type: none"> 1. Weak or dead battery. 2. Corroded battery terminals. 3. Loose or damaged wiring. 4. Faulty solenoid or starter. 	<ol style="list-style-type: none"> 1. Recharge or replace battery. 2. Clean battery terminals. 3. Check all wiring. 4. Check/replace solenoid or starter.
Loss of power	<ol style="list-style-type: none"> 1. Cutting too much grass/too fast. 2. Throttle in "CHOKE" position. 3. Build-up of grass, leaves and trash under mower. 4. Dirty air filter. 5. Low oil level/dirty oil. 6. Faulty spark plug. 7. Dirty fuel filter. 8. Stale or dirty fuel. 9. Water in fuel. 10. Spark plug wire loose. 11. Dirty engine air screen/fins. 12. Dirty/clogged muffler. 13. Loose or damaged wiring. 14. Carburetor out of adjustment. 15. Engine valves out of adjustment. 	<ol style="list-style-type: none"> 1. Set in "Higher Cut" position/reduce speed. 2. Adjust throttle control. 3. Clean underside of mower housing. 4. Clean/replace air filter. 5. Check oil level/change oil. 6. Clean and regap or change spark plug. 7. Replace fuel filter. 8. Drain fuel tank and refill with fresh gasoline. 9. Drain fuel tank and carburetor, refill tank with fresh gasoline and replace fuel filter. 10. Connect and tighten spark plug wire. 11. Clean engine air screen/fins. 12. Clean/replace muffler. 13. Check all wiring. 14. Contact an authorized service center/department. 15. Contact an authorized service center/department.
Excessive vibration	<ol style="list-style-type: none"> 1. Worn, bent or loose blade. 2. Bent blade mandrel. 3. Loose/damaged part(s). 	<ol style="list-style-type: none"> 1. Replace blade. Tighten blade bolt. 2. Replace blade mandrel. 3. Tighten loose part(s). Replace damaged parts.

TROUBLESHOOTING POINTS

PROBLEM	CAUSE	CORRECTION
Engine continues to run when operator leaves seat with attachment clutch engaged	<ol style="list-style-type: none"> 1. Faulty operator-safety presence control system. 	<ol style="list-style-type: none"> 1. Check wiring, switches and connections. If not corrected, contact an authorized service center/department.
Poor cut - uneven	<ol style="list-style-type: none"> 1. Worn, bent or loose blade. 2. Mower deck not level. 3. Buildup of grass, leaves, and trash under mower. 4. Bent blade mandrel. 5. Clogged mower deck vent holes from buildup of grass, leaves, and trash around mandrels. 	<ol style="list-style-type: none"> 1. Replace blade. Tighten blade bolt. 2. Level mower deck. 3. Clean underside of mower housing. 4. Replace blade mandrel. 5. Clean around mandrels to open vent holes.
Mower blades will not rotate	<ol style="list-style-type: none"> 1. Obstruction in clutch mechanism. 2. Worn/damaged mower drive belt. 3. Frozen idler pulley. 4. Frozen blade mandrel. 	<ol style="list-style-type: none"> 1. Remove obstruction. 2. Replace mower drive belt. 3. Replace idler pulley. 4. Replace blade mandrel.
Poor grass discharge	<ol style="list-style-type: none"> 1. Engine speed too slow. 2. Travel speed too fast. 3. Wet grass. 4. Mower deck not level. 5. Low/uneven tire air pressure. 6. Worn, bent or loose blade. 7. Buildup of grass, leaves and trash under mower. 8. Mower drive belt worn. 9. Blades improperly installed. 10. Improper blades used. 11. Clogged mower deck vent holes from buildup of grass, leaves, and trash around mandrels. 	<ol style="list-style-type: none"> 1. Place throttle control in "FAST" position. 2. Shift to slower speed. 3. Allow grass to dry before mowing. 4. Level mower deck. 5. Check tires for proper air pressure. 6. Replace/sharpen blade. Tighten blade bolt. 7. Clean underside of mower housing. 8. Replace mower drive belt. 9. Reinstall blades sharp edge down. 10. Replace with blades listed in this manual. 11. Clean around mandrels to open vent holes.
Headlight(s) not working (if so equipped)	<ol style="list-style-type: none"> 1. Switch is "OFF". 2. Bulb(s) burned out. 3. Faulty light switch. 4. Loose or damaged wiring. 5. Blown fuse. 	<ol style="list-style-type: none"> 1. Turn switch "ON". 2. Replace bulb(s). 3. Check/replace light switch. 4. Check wiring and connections. 5. Replace fuse.
Battery will not charge	<ol style="list-style-type: none"> 1. Bad battery cell(s). 2. Poor cable connections. 3. Faulty regulator (if so equipped). 4. Faulty alternator. 	<ol style="list-style-type: none"> 1. Replace battery. 2. Check/clean all connections. 3. Replace regulator. 4. Replace alternator.
Loss of drive	<ol style="list-style-type: none"> 1. Freewheel control in "disengaged" position. 2. Motion drive belt worn, damaged, or broken. 3. Air trapped in transmission during shipment or servicing. 	<ol style="list-style-type: none"> 1. Place freewheel control in "engaged" position. 2. Replace motion drive belt. 3. Purge transmission.
Engine "backfires" when turning engine "OFF"	<ol style="list-style-type: none"> 1. Engine throttle control not set at "SLOW" position for 30 seconds before stopping engine. 	<ol style="list-style-type: none"> 1. Move throttle control to "SLOW" position and allow to idle for 30 seconds before stopping engine.

SCHEMATIC

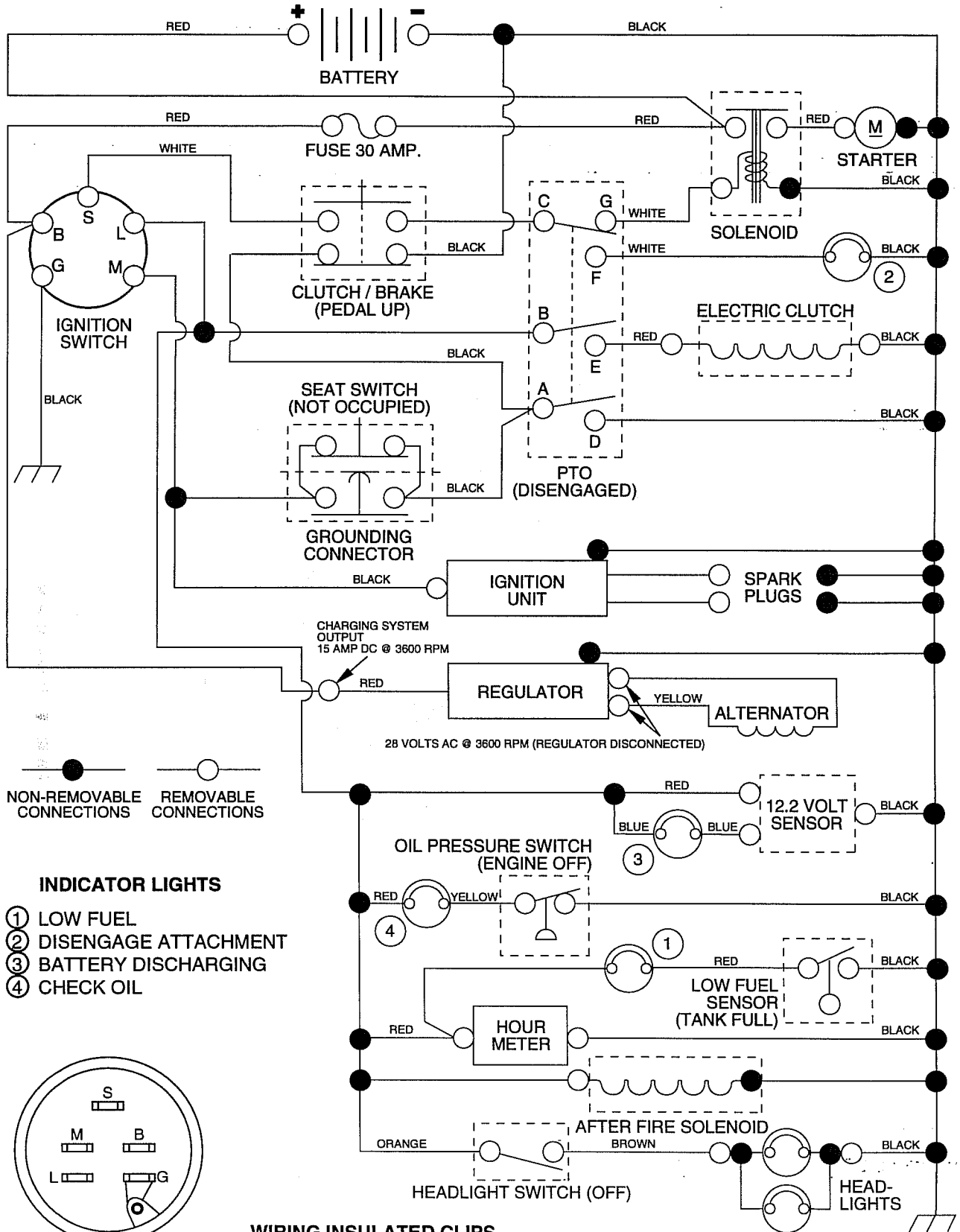

NON-REMOVABLE CONNECTIONS REMOVABLE CONNECTIONS

INDICATOR LIGHTS

- ① LOW FUEL
- ② DISENGAGE ATTACHMENT
- ③ BATTERY DISCHARGING
- ④ CHECK OIL

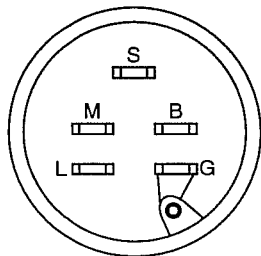

IGNITION SWITCH

POSITION	CIRCUIT
OFF	M + G
ON	B + L
START	B + S + L

WIRING INSULATED CLIPS
NOTE: IF WIRING INSULATED CLIPS WERE REMOVED FOR SERVICING OF UNIT, THEY SHOULD BE REPLACED TO PROPERLY SECURE YOUR WIRING.

PTO SWITCH

POSITION	CIRCUIT
OFF	C + G
ON	C + F, B + E, A + D

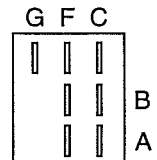

REPAIR PARTS

18 HP 42" TRACTOR - MODEL NO. YTH180(HN18H42A), PRODUCT NO. 954 00 06-62

ELECTRICAL

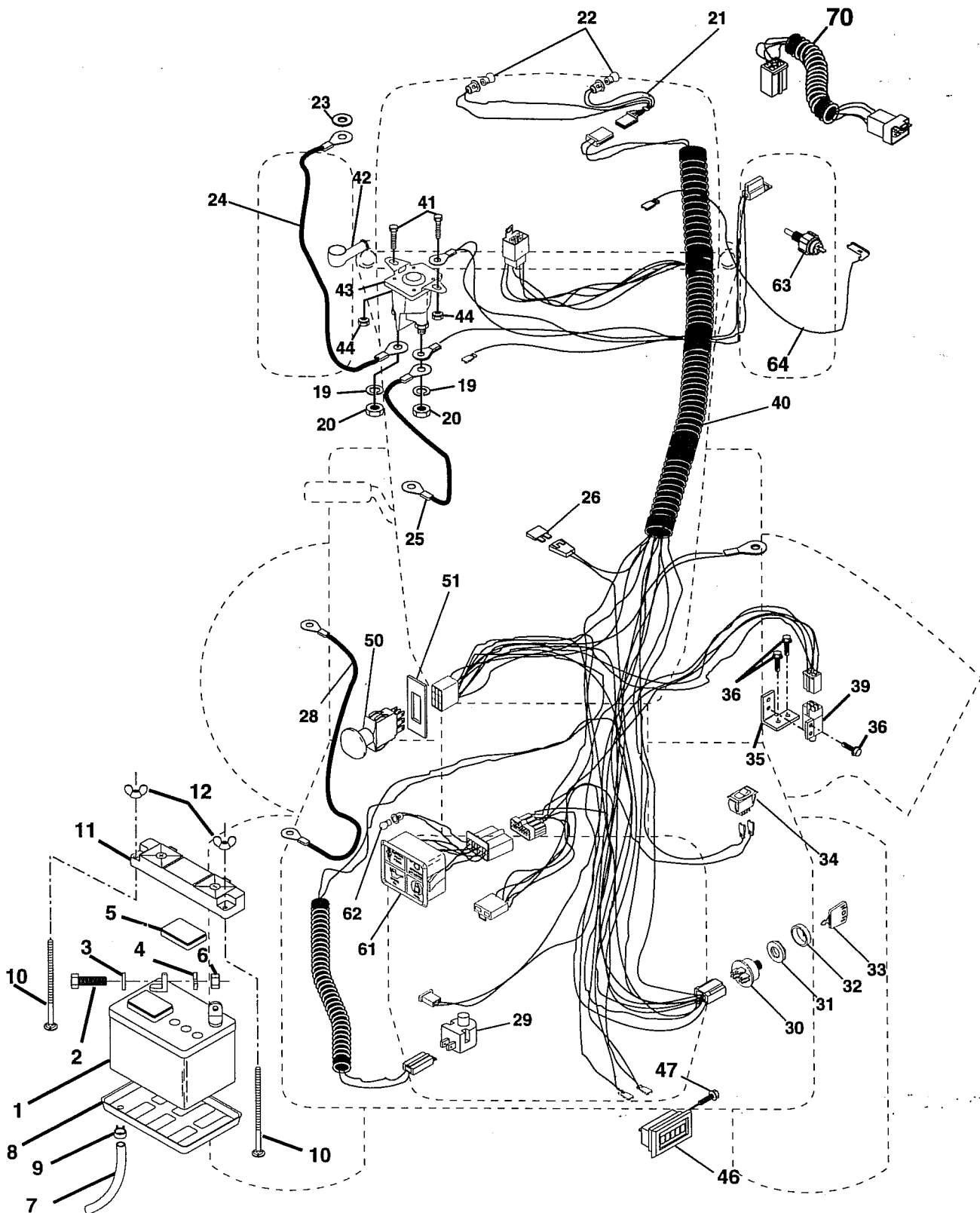

REPAIR PARTS

18 HP 42" TRACTOR - MODEL NO. YTH180(HN18H42A), PRODUCT NO. 954 00 06-62

ELECTRICAL

KEY NO.	PART NO.	DESCRIPTION
1	532121537	Battery
2	874760412	Bolt, Hex Head 1/4-20 x 3/4
3	819091016	Washer 9/32 x 5/8 x 16 Gauge
4	810040400	Washer, Lock 1/4
5	532121264	Caps, Battery
6	873220400	Nut, Hex 1/4-20
7	532007697	Tube, Tray, Battery
8	532124886	Tray, Battery
9	532109596	Clamp, Hose
10	872240460	Bolt, Carriage 1/4-20 x 7-1/2
11	532102476	Guard, Terminal
12	532123198	Nut, Wing 1/4-20
19	810090400	Washer, Lock 1/4
20	873350400	Nut, Hex, Jam 1/4-20
21	532136850	Harness, Socket, Light (Includes Key #11)
22	532004152	Bulb, Light
23	811150400	Washer, Lock, Internal Tooth 1/4
24	532124780	Cable, Starter, 6 Ga 11" Red
25	532124770	Cable, Battery
26	532108824	Fuse
28	532124773	Cable, Battery
29	532121305	Switch, Plunger
30	532140399	Switch, Ignition
31	532140400	Nut, Ignition
32	532141226	Cover, Switch, Ignition
33	532140401	Key, Molded
34	532110712	Switch, Light
35	532108236	Bracket Switch Interlock
36	817021008	Screw, Hex Tap #10-24 UNC
39	532109553	Switch, Interlock (4 Terminal)
40	532141571	Harness, Ignition
41	871110408	Bolt, Hex 1/4-20 x 1/2 Grade 5
42	532131563	Cover, Terminal
43	532138406	Solenoid
44	873640400	Nut, Hex, Keps 1/4-20
46	532110940	Meter, Hour
47	817011008	Screw #10-24 x 1/2
50	532140404	Switch, P.T.O.
51	532140405	Ring, Retainer, Pto
58	532127385	Sensor, Low Voltage
61	532126519	Package, Light
62	532110143	Bulb, Light Package
63	532142320	Switch, Oil Sensor
64	532142321	Wire, Lead, Sentry, Kohler
70	532142047	Harness, Engine

NOTE: All component dimensions given in U.S. inches.

1 inch = 25.4 mm

REPAIR PARTS

18 HP 42" TRACTOR - MODEL NO. YTH180(HN18H42A), PRODUCT NO. 954 00 06-62

CHASSIS AND ENCLOSURES

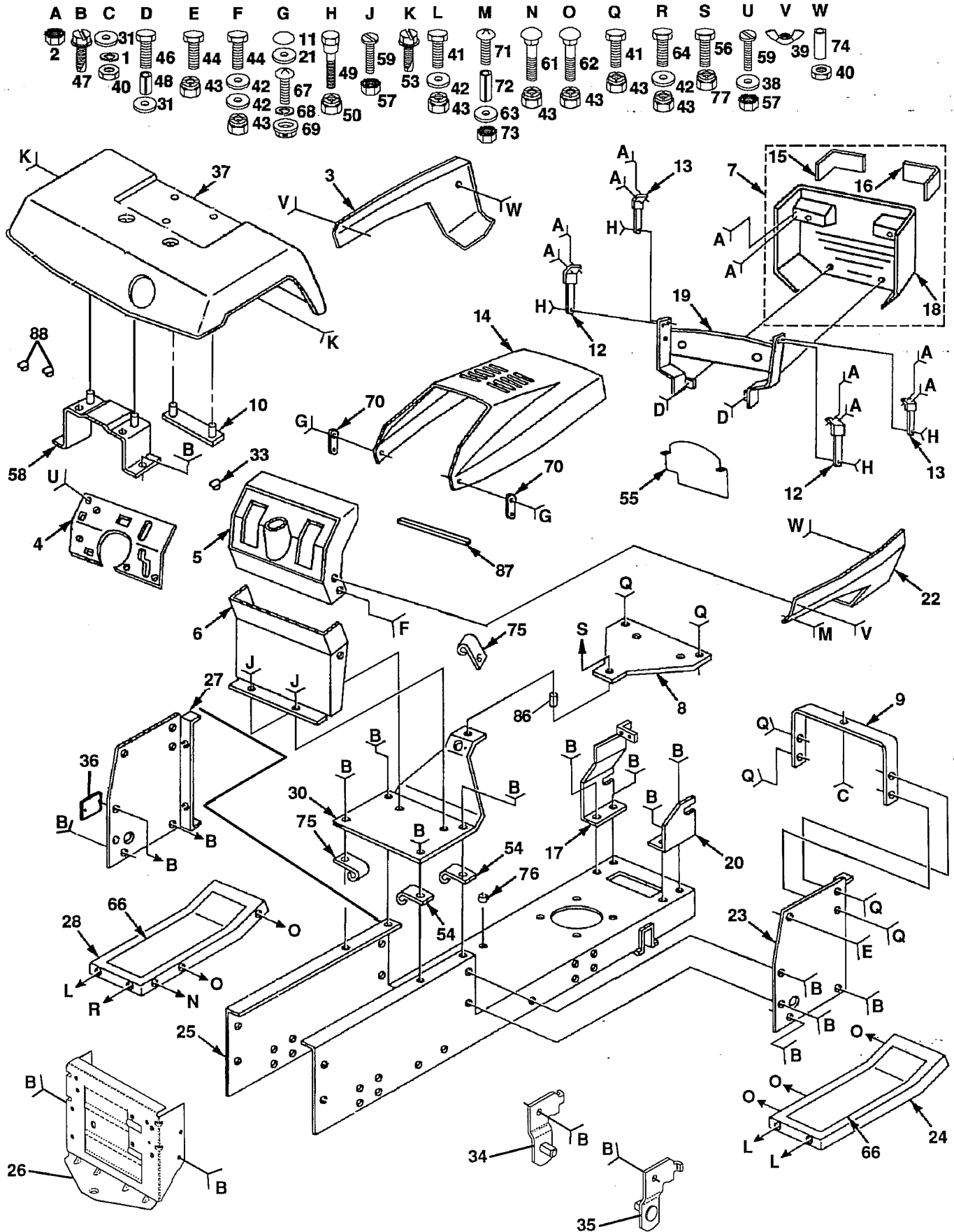

REPAIR PARTS

18 HP 42" TRACTOR - MODEL NO. YTH180(HN18H42A), PRODUCT NO. 954 00 06-62

CHASSIS AND ENCLOSURES

KEY PART NO. NO.	DESCRIPTION	KEY PART NO. NO.	DESCRIPTION		
1	810040400	Washer, Lock, Hvy Hlcl 1/4	42	819131312	Washer 13/32 x 13/16 x 12 Gauge
2	873510400	Nut, Hex, Keps 1/4-20 UNC	43	873680600	Nut, Crownlock 3/8-16 UNC
3	532143364	Side Panel, LH	44	874760616	Bolt, Hex, Fin. 3/8-16 x 1
4	532141626	Plate, Dash	46	874760440	Bolt, Hex 1/4-20 x 2-1/2
5	532140452	Dashboard	47	817490612	Screw, Thd., Roll. 3/8-16 x 3/4
6	532104805	Dash, Lower	48	532121235	Spacer, Split
7	532127320	Grill Assembly	49	532123481	Bolt, Shoulder 1/4-20 UNC
8	532140181	Plate, Battery Support	50	873680400	Nut, Crownlock 1/4-20 UNC
9	532124130	Support, Dash	53	817490608	Screw, Thd., Roll. 3/8-16 x 1/2
10	532140675	Strap, Fender	54	532126471	Clip, Insulator
11	532110356	Cap, Black	55	532126493	Baffle, Vertical
12	532106784	Strap Assembly, Hinge, Rear	56	874760532	Bolt, Hex, Fin. 5/16-18 UNC x 2
13	532104618	Strap Assembly, Hinge, Front	57	873510500	Nut, Hex, Keps 5/16-18 UNC
14	532125007	Hood	58	532137113	Bracket Fender
15	532124250	Lens, Headlight, LH, Smoked	59	874180512	Screw, Machine 5/16-18 UNC x 3/4
16	532124251	Lens, Headlight, RH, Smoked	61	872140608	Bolt, Carriage 3/8-16 UNC x 1
17	532110853	Pivot Bracket Assembly, LH	62	872110606	Bolt, Carriage 3/8-16 x 3/4
18	532127325	Grille	63	819070818	Washer 7/32 x 1/2 x 18 Gauge
19	532124574	Support Assembly, Grille	64	874760614	Bolt, Hex, Fin. 3/8-16 UNC x 7/8
20	532110852	Pivot Bracket Assembly, RH	66	532108256	Pad, Footrest
21	532110357	Washer, Cap	67	874191008	Screw, Machine, Cross Pan Head #10-24 x 1/2
22	532143365	Side Panel, RH	68	810071000	Washer, Lock #10
23	532136970	Dash Panel, RH	69	532125004	Nut, Weld
24	532124914	Footrest, RH	70	532109808	Latch, Chute
25	532140341	Chassis	71	874981020	Screw, Machine, Cross Pan Head #10-24 x 1-1/4
26	532140356	Drawbar	72	532007206	Spacer, Split #10 x 3/4
27	532136967	Dash Panel, LH	73	873731000	Nut, Hex, Keps #10-24 UNC
28	532124899	Footrest, LH	74	532001260	Spacer 17/64 x 1/2 x 3/8
30	532127543	Saddle	75	532124996	Clip, Fuel Line
31	819091216	Washer 9/32 x 3/4 x 16 Gauge	76	532110436	Bushing, Snap Split
33	532125085	Plug, Button	77	873800500	Nut, Lock, Hex w/Ins. 5/16-18
34	532139886	Pivot Bracket Assembly, Rear, LH	86	532121236	Spacer, Split
35	532139887	Pivot Bracket Assembly, Rear, RH	87	532105037	Strip, Foam 18"
36	532121794	Cover Access	88	532105531	Nut, Push, Nylon
37	532141449	Fender			
38	819111116	Washer 11/32 x 11/16 x 16 Gauge			
39	532123198	Wing Nut, Plastic 1/4-20			
40	873220400	Nut, Hex, Fin. 1/4-20 UNC			
41	874760612	Bolt, Hex, Fin. 3/8-16 UNC x 3/4			

NOTE: All component dimensions given in U.S. inches
1 inch = 25.4 mm

REPAIR PARTS

18 HP 42" TRACTOR - MODEL NO. YTH180(HN18H42A), PRODUCT NO. 954 00 06-62

DRIVE

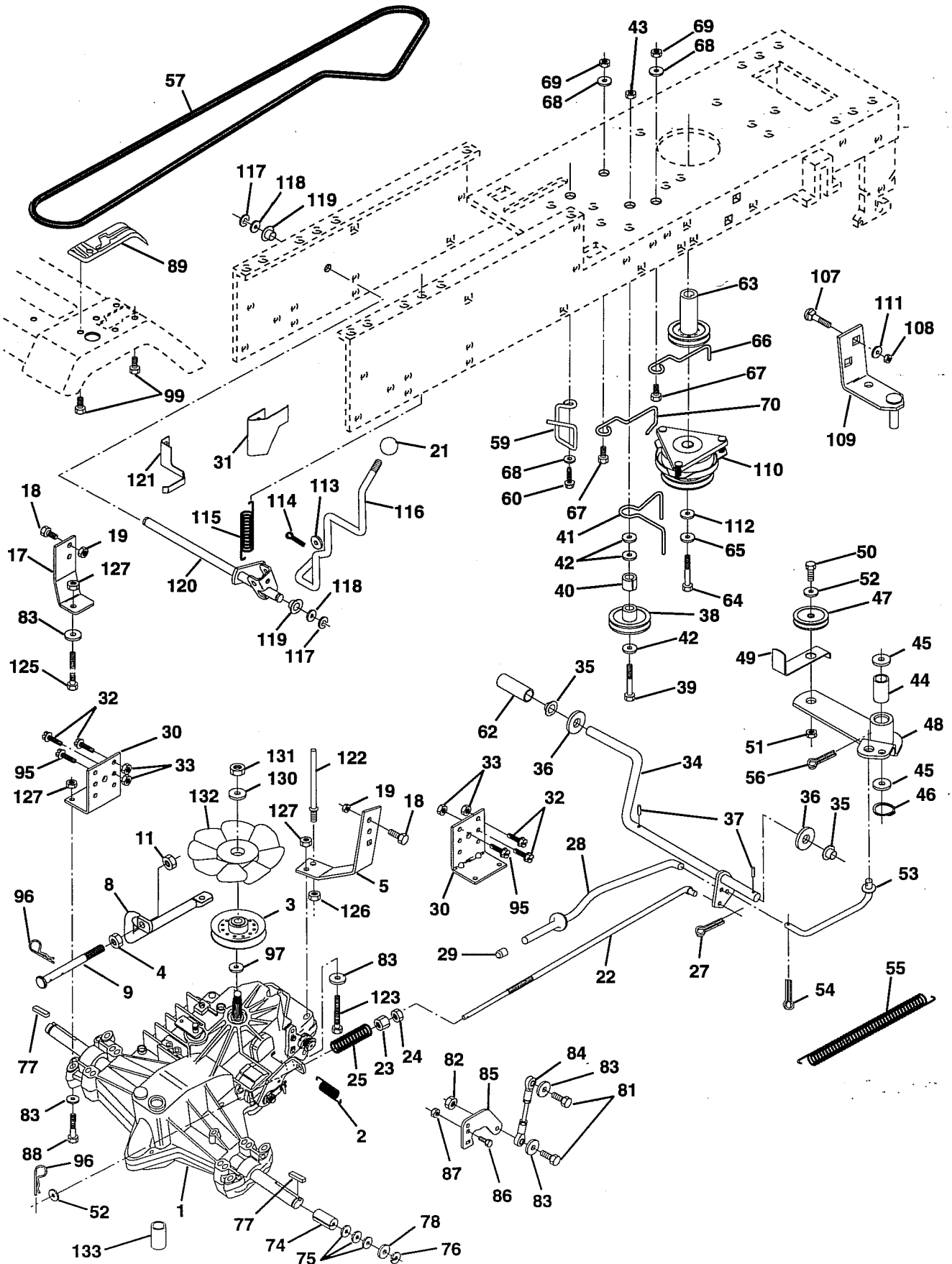

REPAIR PARTS

18 HP 42" TRACTOR - MODEL NO. YTH180(HN18H42A), PRODUCT NO. 954 00 06-62

DRIVE

KEY NO.	PART NO.	DESCRIPTION	KEY NO.	PART NO.	DESCRIPTION
1	532140295	Transaxle Assembly	64	871170768	Bolt, Hex
2	532142431	Spring, Return, Brake	65	810040700	Washer
3	532140293	Pulley, Transaxle	66	532105730	Keeper Belt Engine
4	873350500	Nut Hex Jam 5/16-18 Unc	67	874760616	Bolt
5	532140157	Strap Torque Rh Hydro 18/20" T	68	819131312	Washer 13/32 x 13/16 x 12 Gauge
8	532140357	Control Bypass Hydro 18" Tires	69	873800600	Nut
9	532140550	Rod Bypass Hydro 18/20"	70	532121218	Keeper Belt Engine
11	873800500	Nut Lock Hex W/Ins 5/16-18 Unc P	74	532121199	Spacer, Split
17	532140158	Strap Torque Lh Hydro 18/20" T	75	532121749	Washer 25/32 x 1-1/4 x 16 Gauge
18	874780616	Bolt Fin Hex 3/8-16 Unc x 1 Gr. 5	76	812000001	E-Ring
19	873800600	Nut Lock Hex W/Wsh 3/8-16 Unc	77	532123583	Key, Square
21	532140845	Knob, Duckhead 1/2-13	78	532121748	Washer 25/32 x 1-5/8 x 16 Gauge
22	532140217	Rod, Brake Hydro	81	874780520	Bolt Fin Hex 5/16-18 Unc x 1-1/4
23	873350600	Nut	82	873800500	Nut Lock Hex W/Ins. 5/16-18 Unc P
24	873800600	Locknut	83	819111216	Washer 11/32 x 3/4 x 16 Ga.
25	532106888	Spring, Brake Rod	84	532140548	Rod, Tie Hydro 20" Tires
27	876020412	Pin Cotter 1/8 x 3/4 CAD.	85	532140156	Arm, Control Hydro
28	532133261	Rod, Parking Brake	86	871070516	Screw Cap Hex 5/16 x 18 x 1
29	532071673	Cap, Parking Brake	87	873800500	Nut Lock Hex W/Ins. 5/16-18 Unc P
30	532130807	Bracket, Transaxle	88	874780544	Bolt Fin Hex 5/16-18 Unc
31	532127275	Keeper Belt Lh	89	532139989	Console, Shift
32	874780512	Bolt Hex Hd 5/16-18 Unc x 3/4	95	817490612	Screw, Thdroll. 3/8-16 x 1 Type TT
33	873800500	Nut Lock Hex W/Ins. 5/16-18 Unc	96	532124788	Retainer Spring 1" Zinc/Cad
34	532122424	Shaft, Foot Pedal	97	819211616	Washer 21/32 x 1 x 16 Ga.
35	532120183	Bearing, Nylon	99	532142432	Screw
36	819211616	Washer	107	872140506	Bolt Carriage 5/16-18
37	532124963	Pin, Roll	108	873680500	Nut, Crownlock 5/16-18
38	532123674	Pulley, Idler, Flat	109	532137141	Bracket, Asm Mtg Clutch
39	874760644	Bolt	110	532137140	Clutch, Electric
40	532124965	Spacer, Split	111	819111012	Washer 11/32 x 5/8 x 12 Ga.
41	532109070	Keeper, Belt Retainer	112	532126197	Washer 1-1/2 OD x 15/32 ID x .250
42	819131312	Washer 13/32 x 13/16 x 12 Gauge	113	819171216	Washer 17/32 x 3/4 x 16 Ga.
43	873800600	Nut	114	876020416	Pin Cotter 1/8 x 1 CAD
44	532105706	Bearing, Nylon	115	532123782	Spring Torsion T/A
45	532110812	Washer, Hardened	116	532141002	Rod Shift Fender YT
46	812000039	Ring, Klip	117	812000008	Ring Klip #5304-62
47	532127783	Pulley, Idler, V-Groove	118	819212016	Washer 21/32 x 1-1/4 x 16 Ga.
48	532123789	Bellcrank Assembly	119	532071208	Bushing Rod Steering 629/632 ID
49	532123205	Retainer, Belt	120	532140154	Shaft Asm. Cross Hydro 20" Tires
50	874760624	Bolt	121	532140470	Keeper Belt Lh Hydro 0750. 18/20"
51	873680600	Nut	122	532140469	Keeper Belt Rh Hydro 0750. 18/20"
52	819131316	Washer	123	874780536	Bolt Fin Hex 5/16-18 x 2-1/4
53	532105710	Link, Clutch	125	874780524	Bolt Fin Hex 5/6-18 Unc x 1-1/2
54	876020412	Pin	126	873510600	Nut Keps Hex 3/8-16 Unc
55	532105709	Spring, Return, Clutch	127	873800500	Nut Lock Hex W/Ins 5/16-18 Unc P
56	876020412	Pin	130	532141322	Washer Belleville .501D x 1.50D
57	532140294	V-Belt, Ground Drive	131	532050831	Nut Nylon Insert 1/2-20 Unf.
59	532140312	Keeper, Center Span	132	532140462	Fan, Hydro 7"
60	817490612	Screw Thdroll. 3/8-16 x 3/4 Ty. TT	133	532142564	Line Fuel Hydro 4"
62	532123533	Cover, Pedal			
63	532140189	Pulley, Engine			

NOTE: All component dimensions give in U.S. inches.
1 inch = 25.4 mm.

REPAIR PARTS

18 HP 42" TRACTOR - MODEL NO. YTH180(HN18H42A), PRODUCT NO. 954 00 06-62

STEERING ASSEMBLY

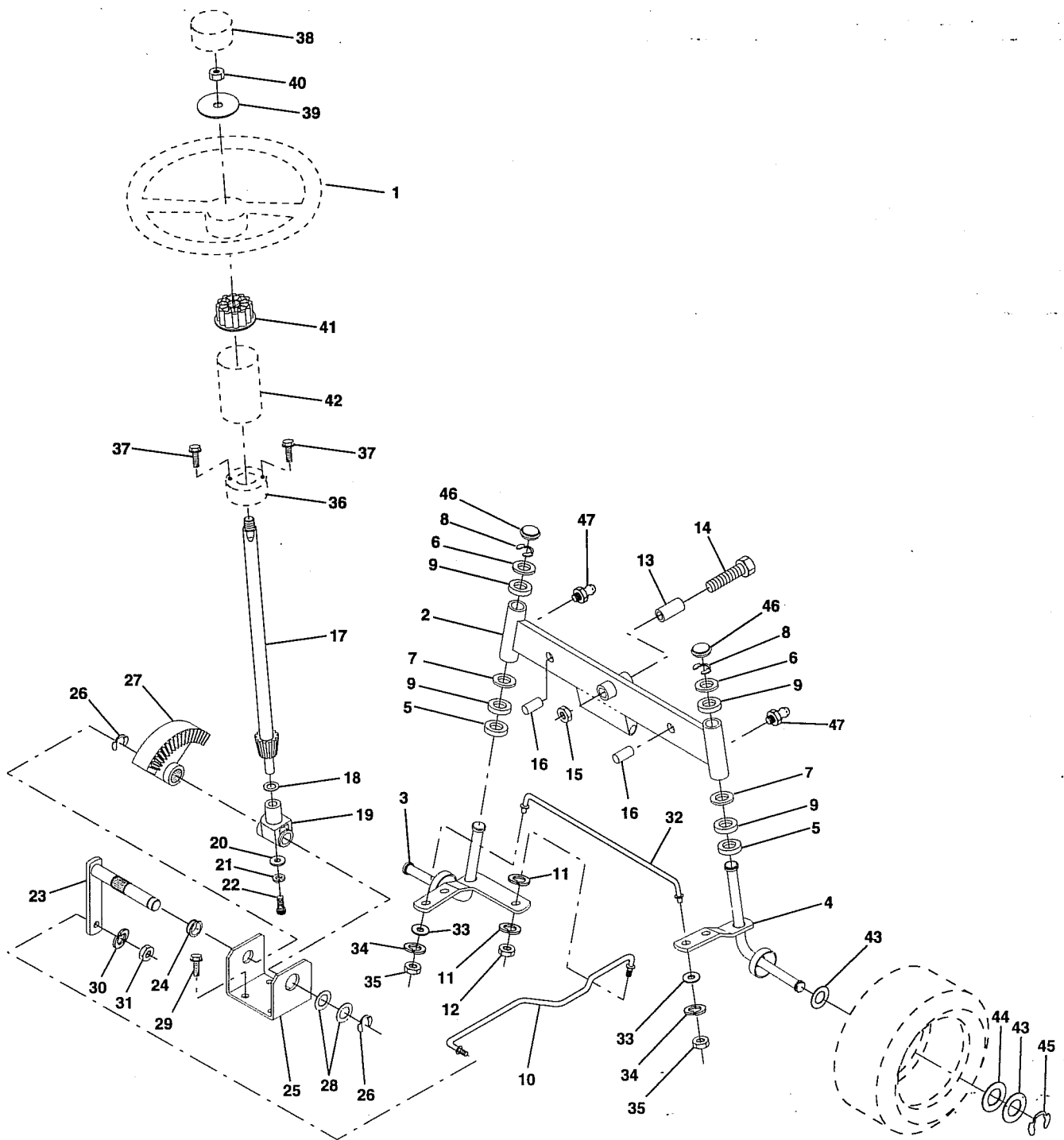

REPAIR PARTS

18 HP 42" TRACTOR - MODEL NO. YTH180(HN18H42A), PRODUCT NO. 954 00 06-62

STEERING ASSEMBLY

KEY PART NO. NO.	DESCRIPTION
1 532124415	Wheel Steering Auto Grey
2 532142033	Axle Asm Fr LT W/gzks 38/42
3 532135227	Spindle Asm LH
4 532135228	Spindle Asm RH
5 532124931	Bearing Race Thrust Harden
6 532121748	Washer 25/32 X 1-5/8 X 16 Ga
7 819272016	Washer 27/32 X 1-1/4 X 16 Ga
8 812000029	Ring Klip #t5304-75
9 532124937	Bearing Col Strg Blk
10 532130468	Link Drag Sol Ball Jt 20 064
11 810040600	Washer Lock Hvy Hlcl Spr 3/8
12 873610600	Nut Fin Hex 3/8-24 Unf
13 532110438	Spacer Bearing Axle Front
14 874011056	Bolt Hex 5/8-11 Unc X 3-1/2
15 873901000	Nut Lock Flange 5/8-11 Unc
16 532132624	Pin Axle 5/8 X 1 55/1 54 Lg
17 532128762	Shaft Asm Strg 20 31 x 3/4 YP YT
18 532057079	Washer Thrust 515x 750x 033
19 532124035	Support Shaft
20 532126684	Washer Shim 1/4 X 5/8 X 062
21 810040400	Washer Lock Hvy Helical 1/4
22 871070410	Screw Hex Socket 1/4-20 X 5/8
23 532127501	Shaft Asm Pittman
24 532109816	Nyliner Snap In
25 532124036	Bracket Steering
26 812000029	Ring Klip #t5304-75
27 532136874	Gear Sector
28 532124931	Bearing Race Thrust Harden
29 817490612	Screw Thdrol 3/8-16x3/4 Ty-tt
30 810040600	Washer Lock Hvy Hlcl Spr 3/8
31 873610600	Nut Fin Hex 3/8-24 Unf
32 532130467	Rod Tie Wire Form 19 75 Elec
33 819111216	Washer 11/32 x 3/4 x 16 Ga.
34 810040500	Washer, Lock Hvy Hlcl Spr 5/16
35 873810500	Locknut 5/16-24 Unf
36 532124720	Bushing Strg Blk 742/747 Id
37 817431008	Screw Slftp #10-16 X 1/2 Ty-b
38 532124416	Insert Cap Strg Wh Aut Hus Gry
39 532100712	Washer 53 X 2 25 X 160 Zinc
40 873940800	Nut Hex Jam Toplock 1/2-20 Unf
41 532100711	Adapter Wheel Strg 758/ 753id
43 532121749	Washer 25/32 X 1 1/4 X 16 Ga
44 532121748	Washer 25/32 X 1-5/8 X 16 Ga
45 812000029	Ring Klip #t5304-75
46 532121232	Cap Spindle Fr Top Blk
47 532124836	Fitting Grease

NOTE: All component dimensions given in U.S. inches
1 inch = 25.4 mm

REPAIR PARTS

18 HP 42" TRACTOR - MODEL NO. YTH180(HN18H42A), PRODUCT NO. 954 00 06-62

SEAT ASSEMBLY

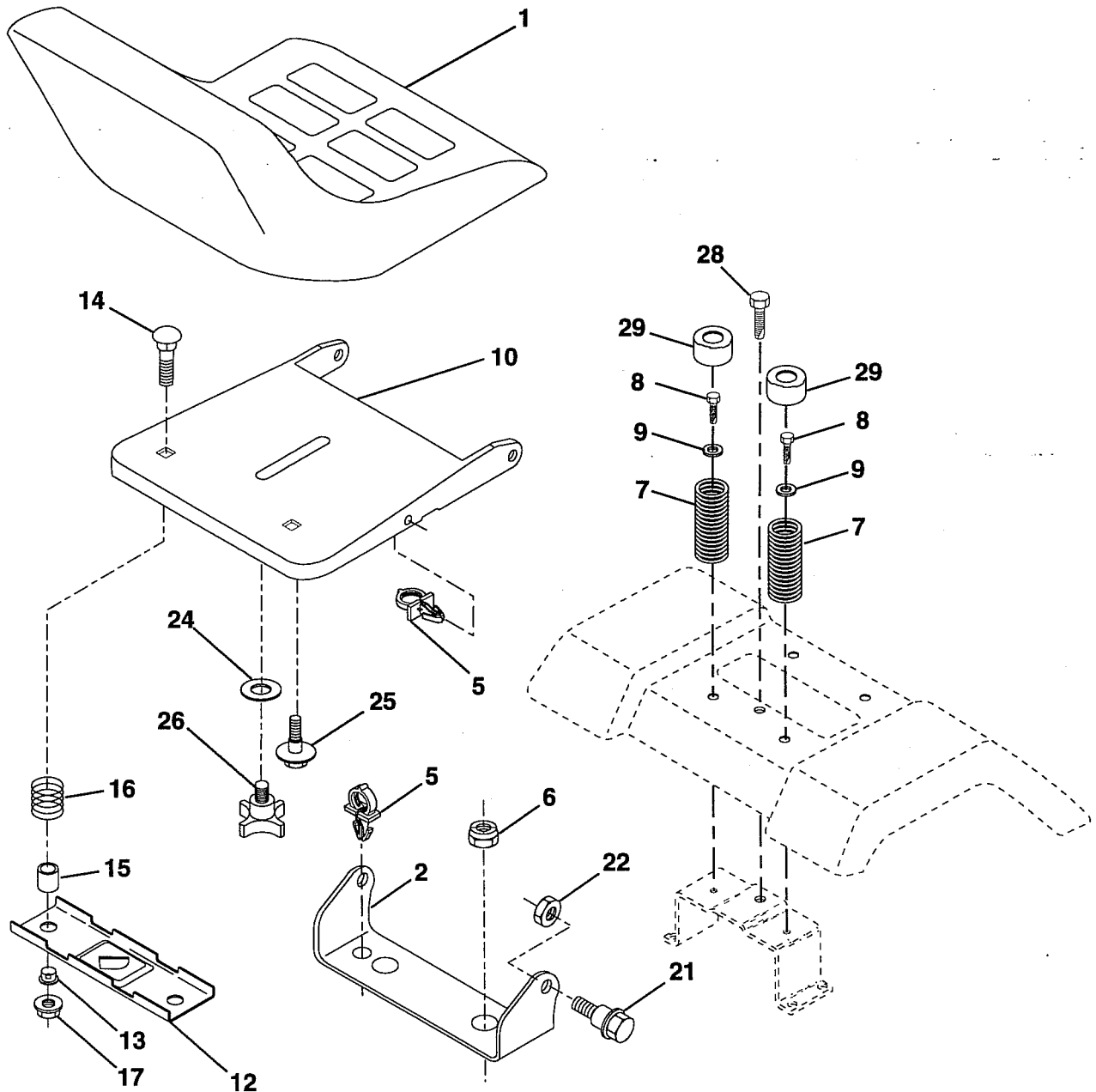

KEY NO.	PART NO.	DESCRIPTION
1	532124186	Seat V-550 Gry/blk Std
2	532140551	Bracket Pivot Seat
5	532140407	Clip, Push-In
6	873800600	Nut Lock Hex w/Wsh 3/8-16 Unc
7	532124181	Spring Seat Cprsn 2 250 Blk Zi
8	817490508	Screw Hwsh Thdrol 5/16-18 x 1/2
9	819131614	Washer 13/32 X 1 X 14 Ga
10	532140552	Pan Seat
12	532121246	Bracket Mounting Switch
13	532121248	Bushing Snap Blk Nyl 50 Id
14	872050411	Bolt Rdhd Sht Nk 1/4-20x1-3/8
15	532121249	Spacer Split 28x 88 Yel Zinc

KEY NO.	PART NO.	DESCRIPTION
16	532123740	Spring Cprsn 1 310 Blk Pnt
17	532123976	Nut Lock 1/4 Lge Flg Gr 5 Zinc
21	532139888	Bolt Shoulder 5/16-18 Unc Blkz
22	873680500	Nut Crown Lock 5/16-18
24	819171912	Washer 17/32 X 1-3/16 X 12 Ga
25	532127018	Bolt Shoulder 5/16-18 X 62
26	532120068	Knob Seat 1/2-13unc Blk
28	817490608	Screw Thdrol 3/8-36 x 1/2
29	532124238	Cap Spring Seat

NOTE: All component dimensions given in U.S. inches
1 inch = 25.4 mm

REPAIR PARTS

18 HP 42" TRACTOR - MODEL NO. YTH180(HN18H42A), PRODUCT NO. 954 00 06-62

DECALS

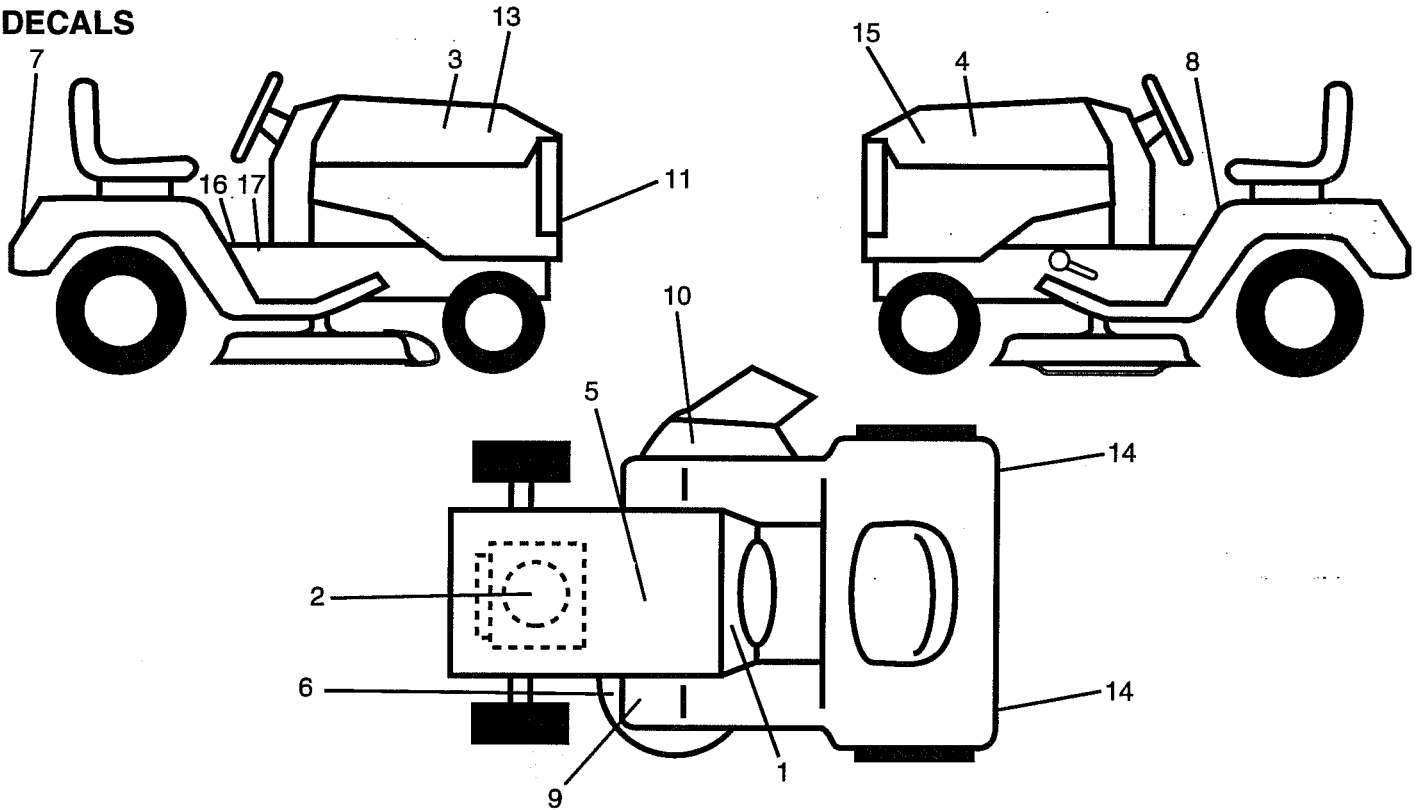

KEY NO.	PART NO.	DESCRIPTION	KEY NO.	PART NO.	DESCRIPTION
1	532138956	Decal Instruction Dash Eng/fr	15	532140729	Decal Hood RH Husqvarna
2	532132507	Decal HP Engine	16	532142337	Decal Sdl Cold Start Hyd E/F
3	532140855	Decal Hood RH Husq YT180 Insert	17	532140837	Decal Brake Parking Saddle
4	532140854	Decal Hood LH Husq YT180 Insert	--	532138311	Decal Lift Handle(Lift Handle)
5	532121549	Decal Caution Battery Fr/ger	--	532142341	Decal Drawbar Cntrl Mvt Hyd LT
6	532136830	Decal V-Belt Sch	--	532142648	Manual Owners, English
7	532131582	Decal Fender Husqvarna	--	532142649	Manual Owners, French
8	532133795	Decal Caution Fender Eng/fr			
9	532101892	Decal Clutch/brake Eng/fr			
10	532137259	Decal Warning MULT-LANGUAGE			
11	532125989	Decal Grille Husqvarna			
13	532140728	Decal Hood RH Husqvarna			
14	532106202	Reflector Tail Light Red/amber			

Available accessories not included with tractor:

- BD20 42" Snow blade
- LC05 33 lb. Weights (pairs)
- SB20 40" Snow Thrower
- CE42 42" Bagger
- TL21 21" P.T.O. Tiller
- MK420 42" Mulcher Kit

WHEELS & TIRES

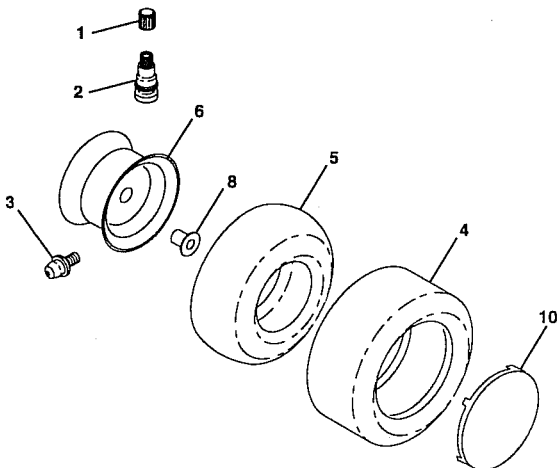

KEY NO.	PART NO.	DESCRIPTION
1	532059192	Cap Valve Tire
2	532065139	Stem Valve
3	532124957	Fitting Grease (Front Wheel Only)
4	532106222	Tire F Ts 15 X 6 0 - 6 Service
	532122082	Tire R Ts 20 X 10 - 8 Service
5	532059904	Tube Front (Service Item Only)
	532124926	Tube Rear (Service Item Only)
6	532141447	Rim Asm 8"rear White Service
	532141446	Rim Asm 6" front White Service
8	532124959	Bearing Flange (Front Wheel Only)
10	532124577	Cover Wheel 6"white
	532124578	Cover Wheel 8"white

NOTE: All component dimensions given in U.S. inches

1 inch = 25.4 mm

REPAIR PARTS

18 HP 42" TRACTOR - MODEL NO. YTH180(HN18H42A), PRODUCT NO. 954 00 06-62

ENGINE

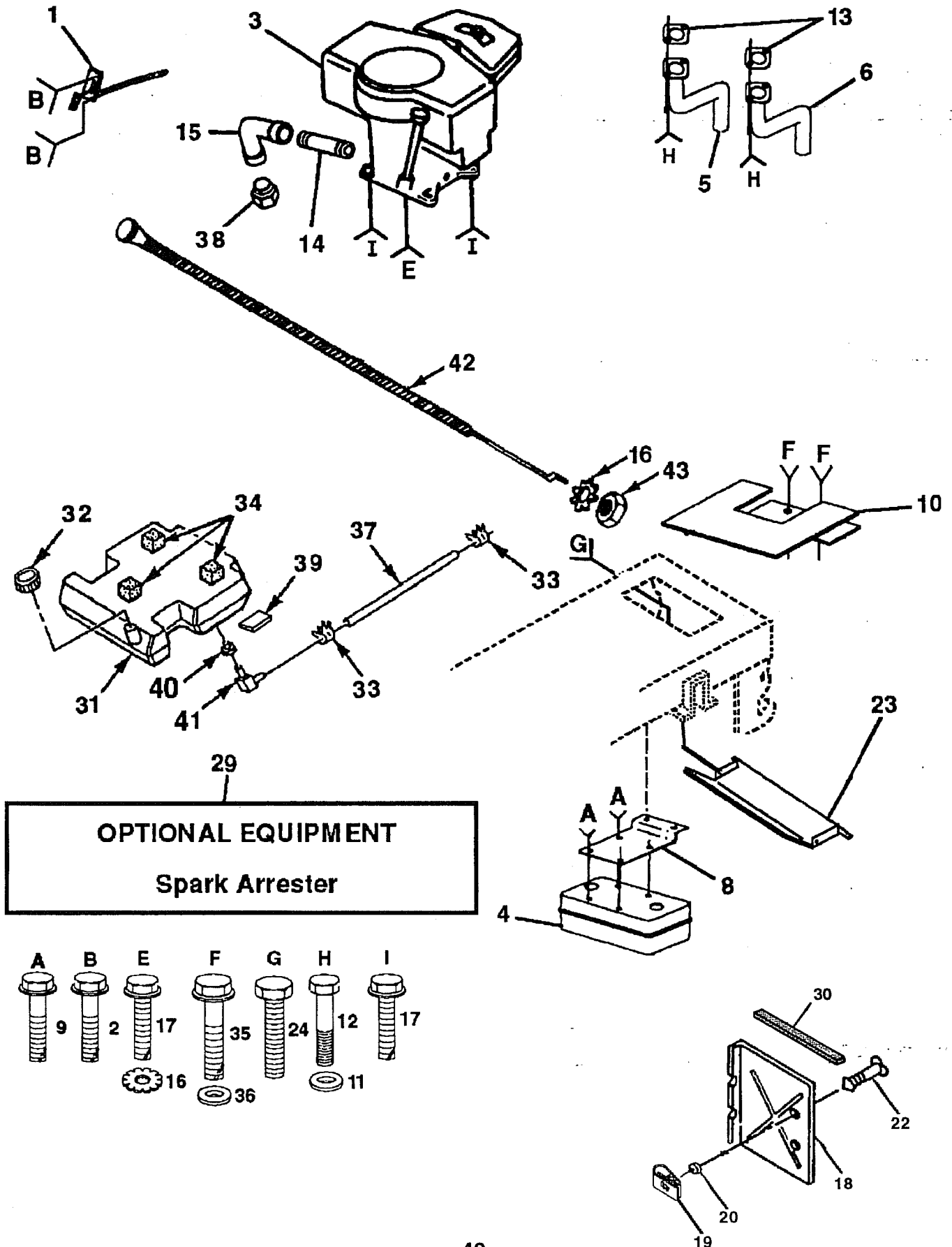

REPAIR PARTS

18 HP 42" TRACTOR - MODEL NO. YTH180(HN18H42A), PRODUCT NO. 954 00 06-62
ENGINE

KEY PART NO. NO.	DESCRIPTION
1 532137214	Control RH Blk Flg 37 88
2 817720410	Screw Hex Thd Cut 1/4-20x5/8 T
3 -----	Engine Kohler, Model No. PS58561
4 532137978	Muffler VGT YT Dual Inlet
5 532136215	Tube Manifold LH
6 532136216	Tube Manifold RH
8 532122439	Bracket Muffler Mounting
9 817190408	Screw Hex Wsh Thd Cut 1/4-20
10 532128199	Shield Heat LT
11 810040500	Washer Lock Hvy Spr 5/16-18
12 874570512	Screw Hex Skt 5/16-18 unc x 3/4
13 -----	Muffler Gasket (Order from Engine Manufacturer)
14 813280336	Nipple Pipe 3/8 Npt X 4-1/2"
15 813200300	Elbow Std 90 Degree 3/8-18 Npt
16 811050600	Washer Lock Ext Tooth 3/8
17 817490624	Screw Thdrol 3/8-16 x 1-1/2
18 532133746	Shield Heat Electric
19 532105839	Receptacle 1/4 Turn
20 532105838	Retainer 1/4 Turn
22 532123650	Stud 1/4 Turn
23 532128953	Shield Heat Browning LT/YT
24 817021008	Screw Tap Hex #10-24unc X 1/2
29 532137180	Kit Spark Arrestor (Flat Scrn)
30 532105037	Foam Strip 18"
31 532141070	Tank Fuel 3 50 Rear
32 532140527	Cap Asm Fuel
33 532123487	Clamp Hose Blk
34 532106082	Pad, Spacer
35 817490512	Screw Thdrol 5/16-18 x 3/4
36 819131614	Washer 13/32 x 1 x 14 Ga.
37 532008543	Line Fuel 54"
38 -----	Plug Oil Drain (Order From Engine Manufacturer)
39 532109227	Pad, Idler
40 532124952	Bushing
41 532139277	Stem Tank Fuel
42 532132782	Choke Control
43 873610600	Nut, Fin Hex 3/8-24 Unf

NOTE: All component dimensions given in U.S. inches.
1 inch = 25.4 mm

REPAIR PARTS

18 HP 42" TRACTOR - MODEL NO. YTH180(HN18H42A), PRODUCT NO. 954 00 06-62

MOWER LIFT ASSEMBLY

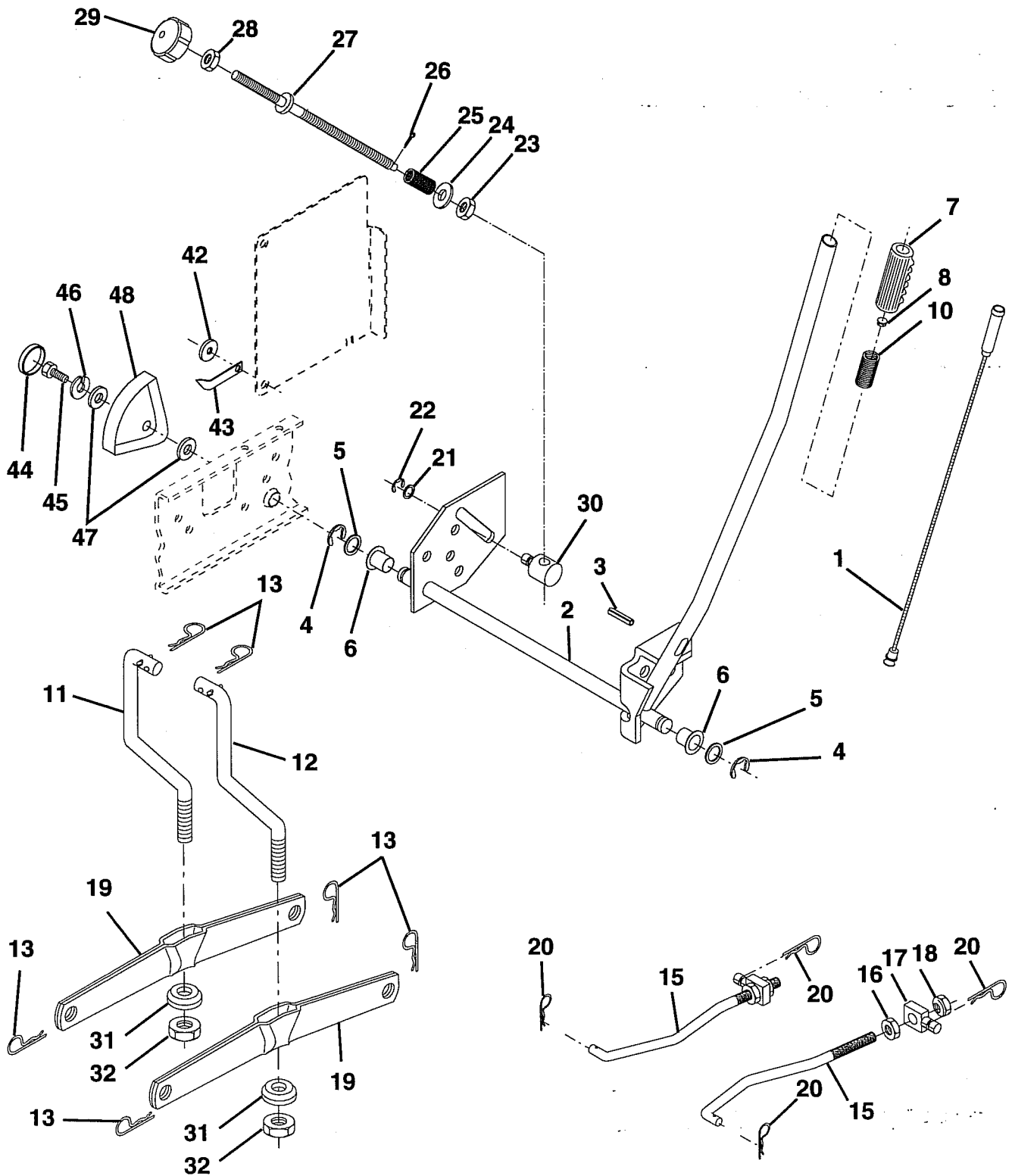

REPAIR PARTS

18 HP 42" TRACTOR - MODEL NO. YTH180(HN18H42A), PRODUCT NO. 954 00 06-62

MOWER LIFT ASSEMBLY

KEY NO.	PART NO.	DESCRIPTION
1	532136971	Wire Asm Inner W/plunger 20 56
2	532136968	Shaft Asm Lift RH w/Inf
3	532138284	Pin Groove 1 500 Zinc
4	812000002	E Ring #5133-62
5	819211416	Washer 21/32 X 7/8 X 16 Ga
6	532120183	Bearing Nylon Blk 629 Id
7	532125631	Grip Handle Fluted Blk
8	532124526	Button Plunger Black
10	532122512	Spring Cprsn 3 750 Oiled
11	532139865	Link Lift LH
12	532139866	Link Lift RH
13	532124670	Retainer Spring
15	532127218	Link Front
16	873350800	Nut Jam Hex 1/2-13 Unc
17	532130171	Trunnion Blk Zinc
18	873800800	Nut Lock W/wsh 1/2-13unc
19	532139868	Arm Suspension Rear
20	532124660	Retainer Spring
21	819151216	Washer 15/32 X 3/4 X 16 Ga
22	812000037	Ring Klip #t5304-37
23	532110807	Nut Special
24	819131016	Washer 13/32 X 5/8 X 16 Ga
25	532124874	Spring 2-1/8"
26	876020308	Pin Cotter 3/32 X 1/2
27	532110729	Rod Adj Lift Zinc 9 00 Wrk Lg
28	873350600	Nut Hex Jam 3/8-16 Unc
29	532138057	Knob Inf 3/8-16 Unc Blk W/sym
30	532110810	Trunnion Dp Stop Dbl Thds PLT
31	532140302	Bearing Pvt Lift Spherical
32	873810600	Nut Lock 3/8-24 w/Nylon Insert
42	532120529	Washer Nylon .44 x .75 x .032
43	532138346	Pointer Height Indicator
44	532123935	Plug Hole Blk 1.485/1.515
45	874780516	Bolt Fin Hex 5/16-18 unc x 1
46	810040500	Washer Lock Hvy Hlcl Spr 5/16
47	819112410	Washer 11/32 x 1-1/2 x 10 Ga.
48	532123934	Scale Ind. Height Blk

NOTE: All component dimensions given in U.S. inches

1 inch = 25.4 mm

REPAIR PARTS

18 HP 42" TRACTOR - MODEL NO. YTH180(HN18H42A), PRODUCT NO. 954 00 06-62
42" MOWER

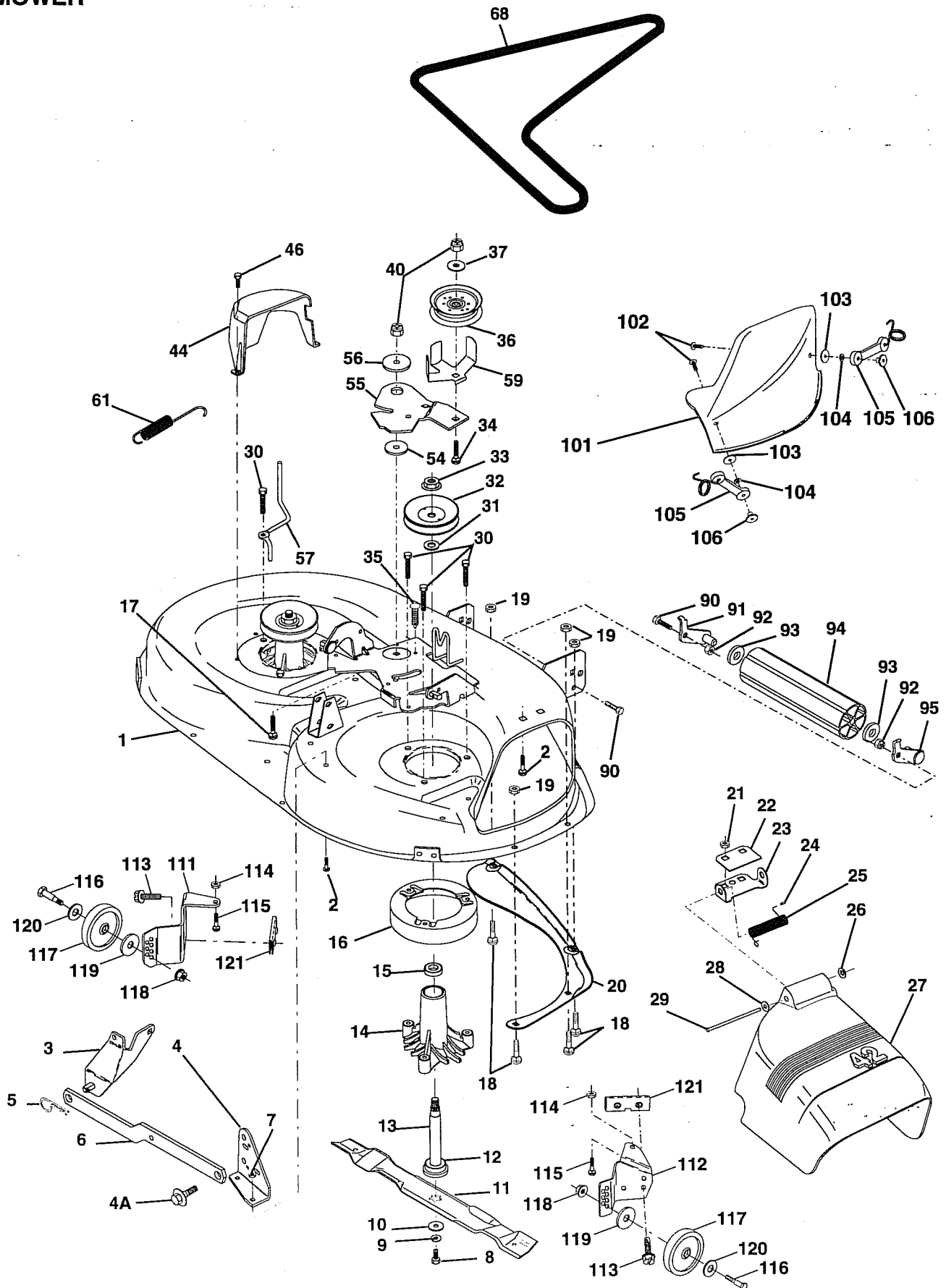

REPAIR PARTS

18 HP 42" TRACTOR - MODEL NO. YTH180(HN18H42A), PRODUCT NO. 954 00 06-62

42" MOWER

KEY PART NO. NO.	DESCRIPTION	KEY PART NO. NO.	DESCRIPTION
1	532140081 Deck Asm MWR 42"weldment	54	532133943 Washer Hardened
2	872140506 Bolt Rdhd Sqnk 5/16-18unc X3/4	55	532140084 Arm Idler 42"mower LT/YT
3	532138017 Bracket Asm Fr Sway Bar 38/42	56	532122052 Spacer Retainer Pm Mower
4	532138440 Bracket Asm Deck 42"sway Bar	57	532140090 Guide, Belt
4A	532132827 Bolt Shoulder	59	532141043 Guard, Belt
5	532124670 Retainer Spring	61	532131950 Spring Ext. Elect
6	532130832 Arm Suspension Rear	68	532140067 V-Belt Mower 42" 92 40
7	873800500 Locknut-hex W/ins 5/16-18unc P	90	874760616 Bolt Fin Hex 3/8-16unc X 1
8	532850857 Bolt 3/8-24x1 25 Gr8 Patched	91	532132274 Bracket Asm Noseroller LH
9	810030600 Washer Lock Hvy 3/8 Unplated	92	873680600 Nut Crownlock 3/8-16 Unc
10	532140296 Washer Hard Blade Mower Vented	93	819171416 Washer 17/32 X 7/8 X 16 Ga
11	532134149 Blade Mower Mulching 42"	94	532132264 Roller Nose 38 & 42
12	532129895 Bearing Ball #6204 (Mandrel)	95	532132273 Bracket Asm Noseroller RH
13	532137645 Shaft Asm W/lower Bearing	101	532136420 Cover Mulching 42" Blk
14	532128774 Housing Mandrel Vented(machd)	102	871161010 Screw
15	532110485 Bearing Ball Mandrel	103	810071000 Washer Lock #10
16	532136929 Stripper Mower Vented	104	819061216 Washer #10
17	872110610 Bolt Rdhd Sqnk 3/8-16 X 1-1/4	105	532130758 Latch Asm Bagger
18	872140505 Bolt Carr 5/16-18 X 5/8	106	532125004 Nut Weld .327/.304 #10-24
19	873800500 Locknut-hex W/ins 5/16-18unc P	111	532140353 Bracket Wheel Guage Lh 42" Deck
20	532136888 Baffle Vortex 42	112	532132262 Bracket Guage Wheel Rh 42" Deck
21	873800500 Nut Lock 5/16-18	113	874760512 Bolt Hex Hd 5/16 - 18 UNC x 3/4
22	532134753 Stiffener Bracket 42"deck	114	873510500 Nut Keps 5/16 - 18 UNC
23	532131267 Bracket Deflector Mower 42"	115	872110504 Bolt Carriage 5/16 - Unc x 1/2
24	532105304 Cap Sleeve 80x 112 Blk Mower	116	532124892 Bolt Shld "A" 2.41 "B" 1.66
25	532123713 Spring Torsion Deflector 2 52	117	532105455 Wheel Guage blk. 4.93
26	532110452 Nut Push Phos & Oil	118	873930600 Nut Centerlock 3/8 - 16 UNC
27	532130968 Shield Deflector Mower 42" Blk	119	819121414 Washer 3/8 x 7/8 x 14 Ga.
28	819111016 Washer 11/32 X 5/8 X 16 Ga	120	819171512 Washer 17/32 x 15/16 x 12 Ga.
29	532131491 Rod Hinge 42"6 75 Wlg	121	532143723 Bracket
30	532138776 Screw Thdrol Hex Hd Zinc Mwr.	--	532140476 Deck Serv 42" Elec Vent (Standard Deck - Order separately nose roller, gauge wheel and mulcher plate components Key Nos. 90-95, 101-106 and 111-121).
31	532129963 Washer Spacer Mower Vented	--	532130794 Mandrel Assembly (Includes Key Numbers 8-10, 12-15, 31 and 33)
32	532129861 Pulley Mandrel 42"		
33	532137266 Nut 9/16top Lock Fling Cntr		
34	872110614 Bolt Rdhd 3/8-16uncx2-3/4 Gr5		
35	532133835 Fastner Christmas Tree		
36	532131494 Pulley Idler Flat 3 060		
37	819131316 Washer 13/32 X 13/16 X 16 Ga		
40	873800600 Nut Lock 3/8-16 Unc		
44	532140088 Guard Mandrel LH Black		
46	532137729 Screw Thdrol 1/4-20x5/8		

NOTE: All component dimensions given in U.S. inches.
1 inch = 25.4 mm

REPAIR PARTS

18 HP 42" TRACTOR - MODEL NO. YTH180(HN18H42A), PRODUCT NO. 954 00 06-62

HYDRO GEAR TRANSAXLE - - MODEL NUMBER 319-0750

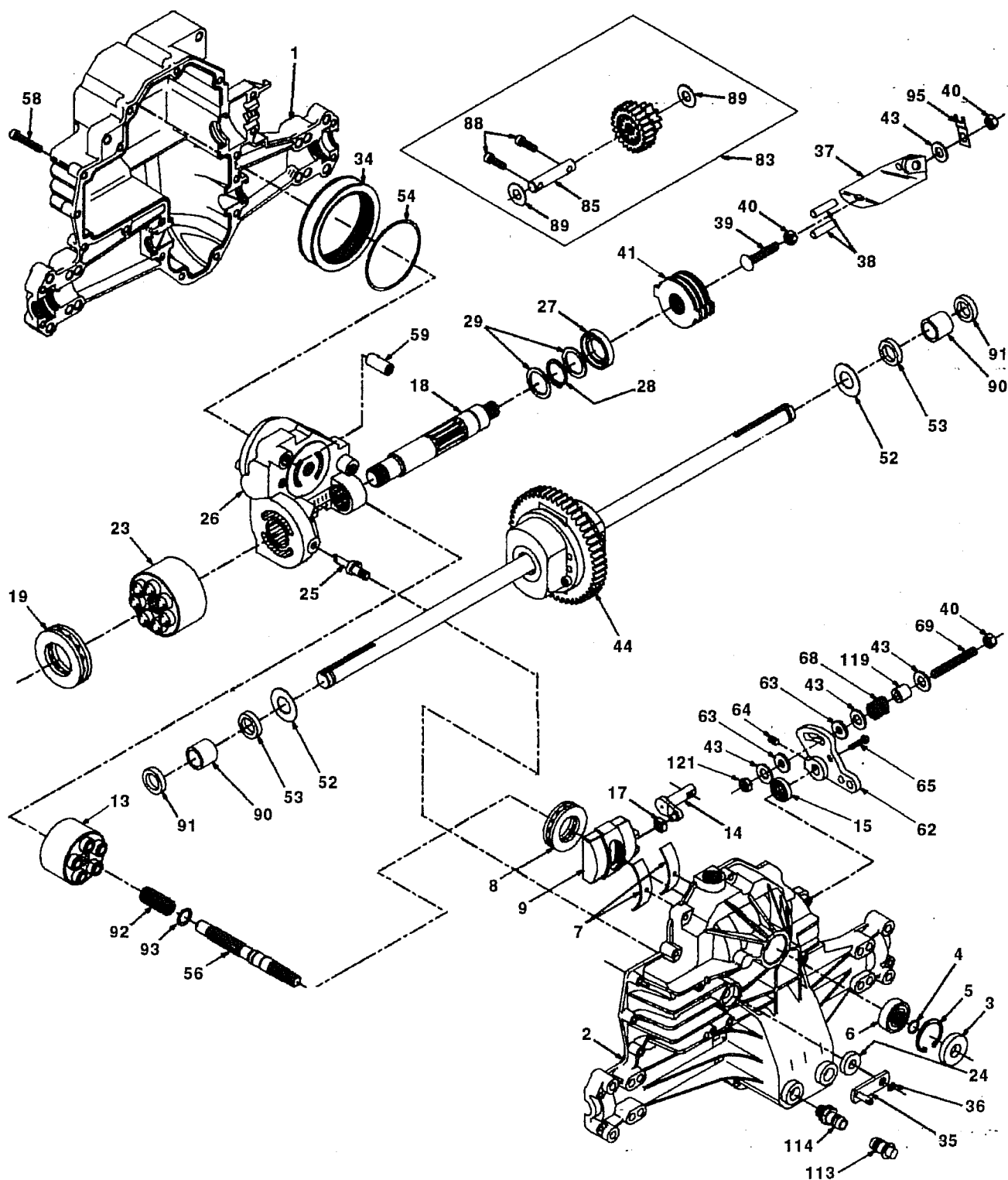

REPAIR PARTS

18 HP 42" TRACTOR - MODEL NO. YTH180(HN18H42A), PRODUCT NO. 954 00 06-62

HYDRO GEAR TRANSAXLE - - MODEL NUMBER 319-0750

KEY PART NO. NO.

DESCRIPTION

1	532142930	Housing, Lower
2	532142931	Assembly, Upper Housing
3	532142932	Seal, Lip
4	532142928	Ring, Wire Retaining
5	532142933	Ring, Retaining
6	532142934	Bearing, Shaft Ball
7	532142935	Bearing, Cradle
8	532142936	Bearing, Thrust 30 x 52 x 13
9	532142937	Swashplate, Variable
13	532142938	Block, Cylinder Assembly
14	532142939	Arm, Trunnion
15	532142940	Seal, Lip
17	532142941	Guide, Slot
18	532142942	Shaft, Motor
19	532142943	Bearing, Thrust 42 x 68 x 16
23	532142944	Block, Cylinder Assembly
24	532142945	Seal, Lip 10 x 25 x 7
25	532142946	Actuator, Bypass
26	532142947	Center Section Assembly Kit
27	532142948	Seal, Lip 26 x 42 x 8
28	532142949	Ring, Retaining
29	532142950	Washer 26 x 35 x 1
34	532142951	Oil Filter Element
35	532142952	Arm, Bypass
36	532142953	Ring, Retaining
37	532142954	Arm, Actuating
38	532142955	Pin, Actuating
39	532142956	Bolt 5/16-24 x 1-3/4
40	532142957	Locknut, Hex 5/16-24 UNJC
41	532142958	Brake Rotor/Stator Kit

KEY PART NO. NO.

DESCRIPTION

43	532142884	Washer 7/16 x 7/8 x .060
44	532142959	Differential Assembly
52	532142960	Washer 3/4 x 1.5 x .03
53	532142961	Seal .75 x 1.25 x .250
54	532142962	O-Ring .103 x 2.987 ID
56	532142963	Shaft, Input
58	532142964	Bolt 1/4-20 x 1.38
59	532142965	Pin .5 OD x .43 ID x .750
62	532142966	Arm, Control
63	532142967	Puck, Dampener
64	532142920	Set Screw
65	532142968	Bolt #8-32 x .875
68	532142969	Spring
69	532142970	Socket Set Screw
83	532142971	Jack Shaft Assembly
85	532142972	Jack Shaft
88	532142973	Capscrew
89	532142974	Washer
90	532142975	Sleeve Bearing
91	532142976	Seal, Wiper
92	532142977	Spring, Block
93	532142978	Washer, Block Thrust
95	532142979	Strap, Locking
113	532142917	Cap, Vent Assembly
114	532142918	Fitting, O-Ring Assembly
119	532142980	Spacer
121	532142981	Jam Nut 5/16-24

NOTE: All component dimensions given in U.S. inches
1 inch = 25.4 mm

SERVICE NOTES

SERVICE NOTES

SUGGESTED GUIDE FOR SIGHTING SLOPES FOR SAFE OPERATION

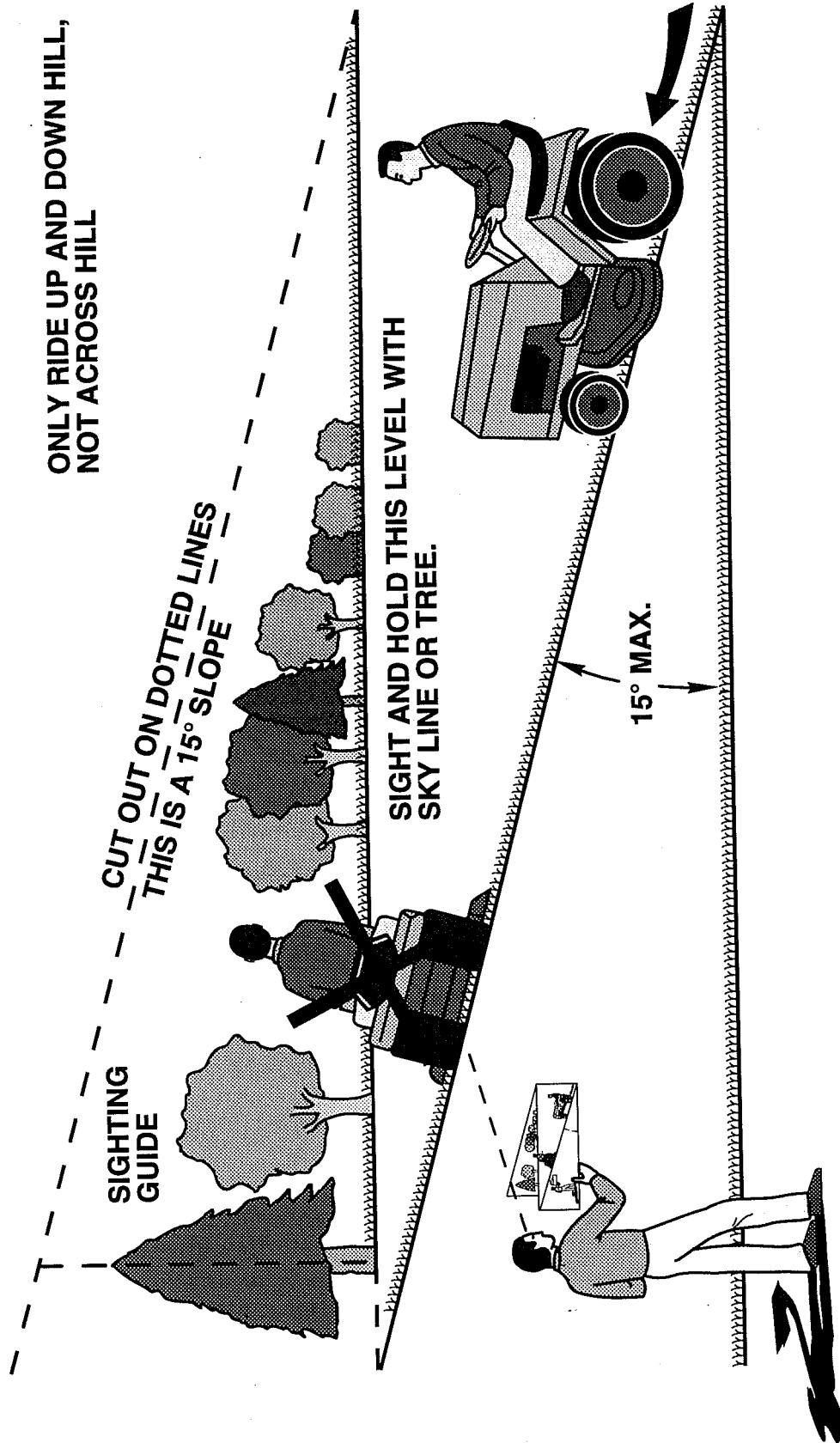

 Operate your Tractor up and down the face of slopes (not greater than 15°), never across the face. Make turns gradually to prevent tipping or loss of control. Exercise extreme caution when changing direction on slopes.



SECTION 1: LIMITED WARRANTY

Husqvarna Forest & Garden Company ("Husqvarna") warrants Husqvarna product to the original purchaser to be free from defective material and workmanship from the date of purchase for the "Warranty Period" here stated dependent upon the type of product use. Warranty period is as follows for products listed:

- 5 Year Warranty: Plastic walk behind mower decks for noncommercial, noninstitutional or nonincome producing use.
- 2 Year Warranty: Riding lawn mowers, yard and garden tractors, walk behind mowers, tillers and attachments for noncommercial, noninstitutional or nonincome producing use. Ignition coils or modules on the chain saws, clearing saws and trimmers.
- 1 Year Warranty: Chain saws, clearing saws, trimmers, blowers and batteries for noncommercial, noninstitutional or nonincome producing use.
- 90 Day Warranty: Any Husqvarna product used for rental, commercial, professional, or income producing use.
- 30 Day Warranty: Husqvarna professional bow bars.
- 30 Day Replacement Part Warranty: Unless otherwise stated, replacement parts are warranted for 30 days from date of purchase.

SECTION 2: HUSQVARNA'S OBLIGATIONS UNDER THE WARRANTY

Husqvarna will remedy defects in material and workmanship during the warranty period by repairing or replacing, at Husqvarna's option, the defective component without charge for parts or labor.

SECTION 3: ITEMS NOT COVERED BY THIS WARRANTY

The following items are not covered by this warranty:

- (1) Normal customer maintenance items (i.e., belts, blades, blade adapters, bulbs, filters, guide bars, lubricants, rewind springs, saw chain, spark plugs, starter ropes and tires).
- (2) Normal wear, normal adjustment, standard hardware or items worn through regular use.
- (3) Natural discoloration of material due to ultraviolet light.
- (4) The replacement or maintenance of worn items.
- (5) Briggs & Stratton, Kawasaki and Kohler engines, including starters, generators, alternators and accessories. These items are covered by the engine manufacturer's warranty as stated with the product information supplied at the time of purchase. All claims for specified engines, starters, generators, alternators and accessories should be sent to the appropriate manufacturer.
- (6) Agri-Fab, Foote, and Tecumseh-Pearless drive systems. These items are covered by the drive system manufacturer's warranty as stated with the product information supplied at the time of purchase. All claims for specified drive systems should be sent to the appropriate manufacturer.

SECTION 4: EXCEPTIONS AND LIMITATIONS

This warranty shall be inapplicable to defects resulting from the following:

- (1) Accident, abuse, misuse, negligence and neglect, including stale fuel, dirt abrasives, moisture, rust, corrosion, or any adverse reaction due to incorrect storage habits.

- (2) Failure to operate or maintain the unit in accordance with the Owner's/Operator's manual or instruction sheet furnished by Husqvarna.
- (3) Alterations or modifications that affect the unit's performance, operation, safety, durability, change its intended use, or cause failure of compliance with current regulatory standards or applicable federal, state or local laws.
- (4) Use of parts or accessories which are not recommended by Husqvarna Forest & Garden Company.
- (5) Additional damage to parts or components due to continued use occurring after any of the above.

REPAIR OR REPLACEMENT AS PROVIDED UNDER THIS WARRANTY IS THE EXCLUSIVE REMEDY OF THE CONSUMER. HUSQVARNA SHALL NOT BE LIABLE FOR ANY INCIDENTAL OR CONSEQUENTIAL DAMAGES FOR BREACH OF ANY EXPRESS OR IMPLIED WARRANTY ON THESE PRODUCTS EXCEPT TO THE EXTENT PROHIBITED BY APPLICABLE LAW. ANY IMPLIED WARRANTY OF MERCHANTABILITY OR FITNESS FOR A PARTICULAR PURPOSE ON THESE PRODUCTS IS LIMITED IN DURATION TO THE WARRANTY PERIOD AS DEFINED IN THE LIMITED WARRANTY STATEMENT. HUSQVARNA RESERVES THE RIGHT TO CHANGE OR IMPROVE THE DESIGN OF THE PRODUCT WITHOUT NOTICE, AND DOES NOT ASSUME OBLIGATION TO UPDATE PREVIOUSLY MANUFACTURED PRODUCTS.

Some states do not allow the exclusion of incidental or consequential damages, or limitations on how long an implied warranty lasts, so the above limitations or exclusions may not apply to you. This warranty gives you specific legal rights, and you may also have other rights which vary from state to state.

SECTION 5: CUSTOMER RESPONSIBILITIES

The customer must exhibit reasonable care, maintenance, operation, storage and general upkeep as written in the maintenance section of the Owner's/Operator's manual. Should an operational problem or failure occur, the product should not be used, but delivered as is to an authorized Husqvarna dealer for evaluation. Proof of purchase, as explained in section 6, rests solely with the customer.

SECTION 6: PROCEDURE TO OBTAIN WARRANTY CONSIDERATION

It is the Owner's and Dealer's responsibility to make certain that the Warranty Registration Card is properly filled out and mailed to Husqvarna Forest & Garden Company. This card should be mailed within ten (10) days from the date of purchase in order to validate the warranty and to provide post-sale service.

Proof of purchase must be presented to the authorized Husqvarna dealer in order to obtain warranty service. This receipt must include date purchased, model number, serial number, and complete name and address of the selling dealer.

To obtain the benefit of this warranty, the product believed to be defective must be delivered in a timely manner, within thirty (30) days from date of operational problem or failure, and during the warranty period, to any authorized Husqvarna dealer. The product must be delivered to the dealer, at the owner's expense. An authorized Husqvarna dealer can be normally located through the "Yellow Pages" of the local telephone directory.

HUSQVARNA FOREST & GARDEN CO.
 9006-J PERIMETER WOODS DRIVE
 CHARLOTTE, NORTH CAROLINA 28216

142648

954 00 06-62

532142648 01.12.94

Printed in U.S.A.

142648