

**READ THESE INSTRUCTIONS
CAREFULLY!
KNOW YOUR CONTROLS.
LEARN HOW TO STOP YOUR
TRIMMER IN AN EMERGENCY**

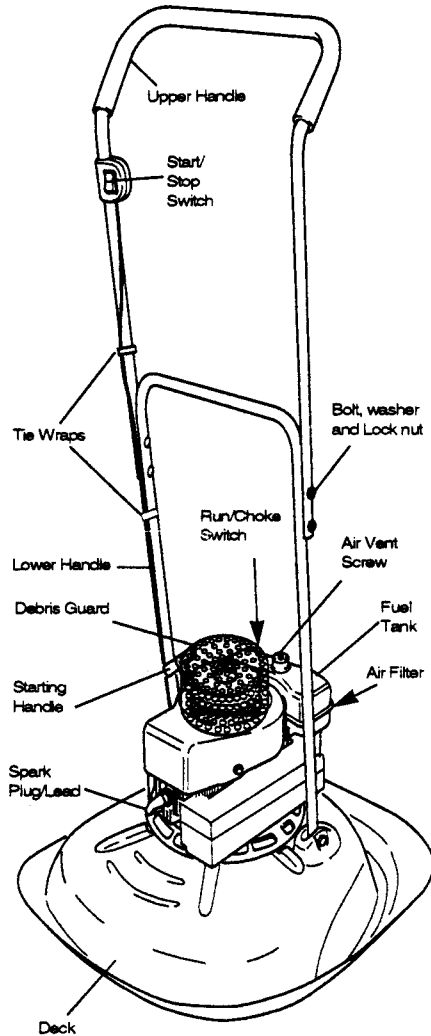

PREPARATION

Before using your new Husqvarna Hover Trimmer, make a careful note of the details on the serial number label, which can be found on the rear of the deck. Always quote these details to your dealer when enquiring about spares and service.

ASSEMBLY OF LOWER HANDLE TO DECK

With the trimmer on the ground:

1. Remove the bolts (1), washers (2) and lock nuts (3) from the polythene bag.
2. Secure the lower handle (4) by placing bolts (1) through deck brackets (5) and lower handle (4).
3. Place washer (2) on bolt and secure with lock nut (3).

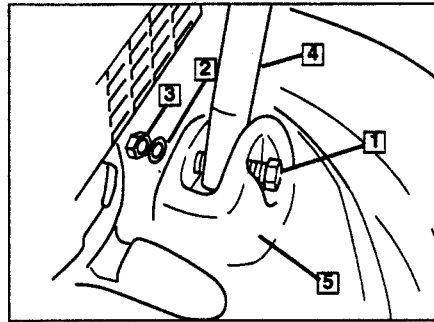

ASSEMBLY OF UPPER HANDLE TO LOWER HANDLE

Assemble upper handle (6) to lower handle (7) by fitting bolts (8) and washers (9) and securing with lock nuts (10).

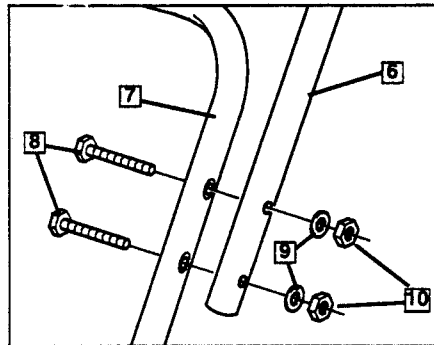

HANDLE POSITION

The handle position can be altered by moving it forward for the park position or back for the trimming position.

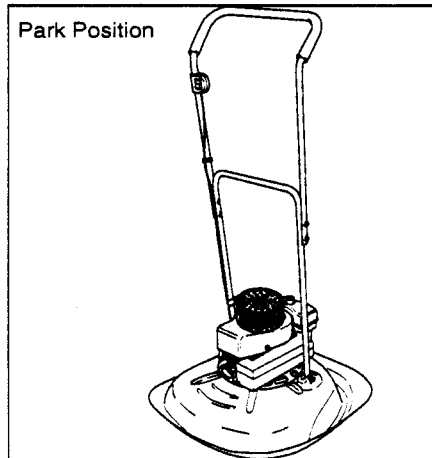

Trimming Position



CARRYING THE TRIMMER

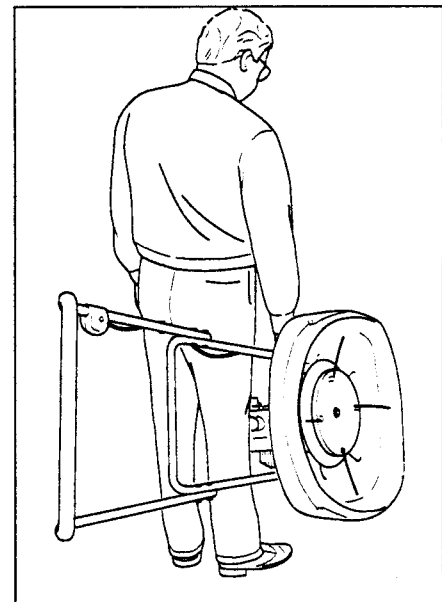

NOTE:

Before carrying the machine from one trimming area to another, close fuel tank air vent screw, close fuel tap, and let engine continue to run until it stops (in order to empty the carburettor bowl) then disconnect the spark plug lead. Carry the trimmer at the point of balance (see illustration) with the cutting head away from you.

**NEVER CARRY THE TRIMMER
WHEN IT IS RUNNING.**

WARNING AND SAFETY INSTRUCTIONS

THE FOLLOWING WARNING IS ATTACHED TO THE TRIMMER AND MUST BE ADHERED TO AT ALL TIMES.

Read Operator's manual. * Remove objects that can be thrown by trimmer. * Do not trim when children and others are around. * Wear safety glasses while operating machine. * Do not use on slopes which are wet or too steep to maintain firm footing. * Be sure trimmer has stopped before placing hands or feet near cutting head. * Do not fit a metal/bar blade as a cutting mechanism on this machine. * Use only the cutting head device approved by the Manufacturer. * Cutting head continues to rotate after machine is switched off. * Disconnect spark plug lead before cleaning or adjusting the machine.



OPERATORS SAFETY

1. Always wear eye protection or safety goggles to protect against objects thrown out by the cutting line.
2. Always wear long trousers, gloves and heavy shoes.
3. Only use the trimmer in the manner and for the functions described in these instructions.
4. Never operate the trimmer when you are tired, ill or under the influence of alcohol, drugs or medicine.
5. Only allow persons over the age of 16 and who have read and understood these instructions to use this trimmer.
6. Wear hearing protection if you use this trimmer for more than 1 1/4 hours per day.
7. Start the engine carefully following the 'Starting Instructions', never start or run the engine inside a closed room or building. Breathing exhaust fumes can kill.
8. Keep handles free from oil and fuel.

FUEL SAFETY

1. Use a container approved for the storage of gasoline.
2. Mix and fill fuel tank outdoors where there are no sparks or flames.
3. Do not remove tank cap or fill the tank while the engine is running.
4. Do not smoke or allow smoking while you are filling the tank near stored fuel, the trimmer, or while using the trimmer.
5. Avoid spilling fuel, wipe up any spillage immediately.
6. Move at least 10 feet away from the fuelling site before starting the engine.
7. Empty the fuel tank before storing the trimmer.
8. Store machine and fuel in an area where fuel vapours cannot reach sparks or open flames from water heaters, electric motors or switches, furnaces etc.

IF NOT USED PROPERLY, THIS TRIMMER CAN BE DANGEROUS

This trimmer can cause serious injury or death to the operator and others. The warnings and safety instructions must be followed.

The operator is responsible for following the warnings and instructions in this manual and on the trimmer. Read the entire Operator's manual before assembling and using this trimmer. Restrict the use of this trimmer to persons who have read, or been instructed in the use of, understand and will follow all warnings and instructions issued with this trimmer.

CUTTING SAFETY

1. Inspect the area to be cut before each use. Remove all objects such as stones, broken glass, nails, wire, string etc., which can be thrown or become entangled in the trimmer line.
2. Keep others including children, animals and bystanders, a safe distance away from the trimmer. Stop the trimmer immediately if you are approached.
3. Hold the trimmer firmly with both hands.
4. Only trim in daylight or good artificial light.
5. Keep a firm footing and balance, especially on wet or damp grass.
6. Keep the trimmer flat on the grass when in use.
7. Do not overreach.
8. Do not walk backwards.
9. Exercise extreme caution on slopes. Carefully follow the instructions. "USING THE TRIMMER ON SLOPES".
10. Stop the engine before taking the trimmer across any surface other than grass.
11. Never pick up or carry the trimmer while the engine is running.
12. Never leave the trimmer unattended while the engine is running.
13. Keep hands and feet away from the underside of the deck, the fast rotating cutting line cannot be seen.
14. The cutting line continues to rotate after the engine has been switched off.

Use only for jobs explained in this manual. If situations occur which are not covered in this manual, use care and good judgement. Contact your dealer if you need assistance.

TOOL SAFETY

1. Always be sure the trimmer is in a safe operating condition. Use only genuine Husqvarna parts and accessories specified for the product.
2. Only use Husqvarna replacement cutting line, do not use wire, string or rope etc.
3. Inspect the trimmer each time before use, especially the cutting line and mounting disc.
4. Do not use if any parts appear or are damaged or broken, or if any screws are loose. Have it repaired.
5. Never use, or attempt to fit, a metal/bar blade with this product.
6. If the trimmer starts to vibrate abnormally, stop the engine immediately and investigate the cause. (If in doubt, contact your service dealer).
7. Never allow grass to collect around the engine, especially the cooling air inlet and outlet. Overheating will damage the engine.
8. Do not overspeed the engine or alter the governor settings. Excessive speed is dangerous and can shorten engine life.

MAINTENANCE SAFETY

1. Always switch off and disconnect the spark plug lead before performing any maintenance or cleaning.
2. Have all servicing, other than cutting line replacement, carried out by a qualified service engineer.
3. Use only genuine Husqvarna replacement parts. Failure to do so could create a hazard and may invalidate your warranty.
4. Clean after use. Never clean your trimmer with water, just use a dry cloth or soft brush, never use cleaning fluids or solvents.
5. Allow the engine to cool before storing the trimmer. Store the trimmer in a dry, damp-proof, secure area, out of reach of children.

HOW TO USE YOUR TRIMMER

FUEL MIXTURE

To operate the engine, you will need the following:-

1. **A clean, high quality 2 cycle oil.**

Tecumseh specially formulated oil is available at any Authorised Tecumseh Service Outlet. Order as part number 730227.

Do not use multi-viscosity oils.

Disregard mix ratio instructions on oil containers if instructions conflict with fuel mix chart below.

Fuel Mix Chart		Mixture 32:1	
U.S.		S.I. (Metric)	
Gas	Oil to be added	Petrol	Oil to be added
1 Gal.	4 oz.	4 Litres	125 ml
2 Gal.	8 oz.	8 Litres	250 ml
5 Gal.	20 oz.	20 Litres	625 ml

2. **A fresh, clean, unleaded regular automotive gasoline.** (Leaded regular and unleaded or leaded premium grades of gasoline are acceptable substitutes.)

Note: **Do not** use gasoline containing methanol (wood alcohol). Gasoline containing up to 10% ethanol or grain alcohol ("Gasohol") may be used but requires special care when engine is unused for extended periods.

Do not attempt to mix oil and gasoline in the engines own fuel tank.

Ensure that the fuel in both the fuel mixture container and the engines fuel tank are thoroughly mixed before use.

Do not fill the fuel tank in an enclosed area, when the engine is hot or while you are smoking.

Thoroughly clean around the fuel tank filler cap before filling, this will help to prevent dirt being introduced into the fuel system.

Do not fill the tank while the engine is running. Fill the fuel tank through a funnel fitted with a fine filter.

Never fill fuel tank completely. Fill tank to 1/2" below bottom of filler neck to provide for fuel expansion. Fuel should be stored in a cool place away from naked flames.

Your carburettor is pre-set. Normally no further adjustment is required.

STARTING

STARTING

1. Before starting, move handle to park position.

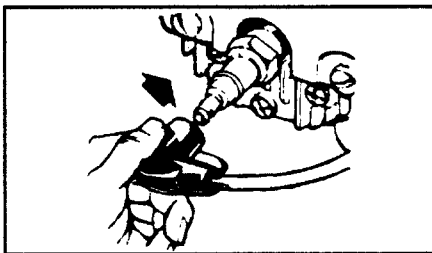

2. Connect spark plug lead.

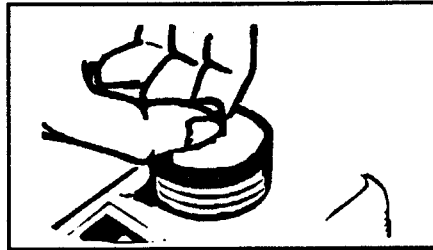

3. Open fuel tank air vent screw (anti-clockwise).

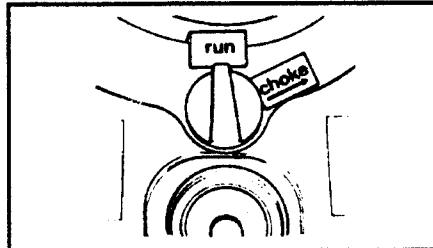

4. COLD START

If engine is cold, move Run/Choke switch to 'Choke' position.

HOT START

If engine is warm, move Run/Choke switch to 'Run' position.

5. Move switch on handle to 'Start' position.

START - I STOP - O

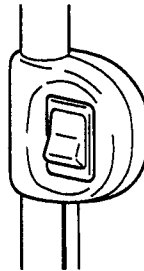

6. Place your right foot on the deck and grasp the far arm of the handle with your left hand. Tilt the trimmer towards you. Pull starting handle gently until you feel compression. Let the starting handle return slowly. Firmly pull the starting handle the full length, and the engine should start; if not, repeat the above procedure.



7. After engine has started move Run/Choke switch to 'Run' position and allow engine to warm up a minute or so before gently lowering trimmer to horizontal floating position. Move handle to operating position.

STOPPING THE ENGINE

1. Place handle in park position and tilt trimmer as for starting.
2. While trimmer is tilted move stop/start switch to stop position. When engine has completely stopped, the trimmer can be allowed to stand flat.
3. Disconnect the spark plug lead and keep it from making contact with plug. Close fuel tank air vent screw (clockwise).

HOW TO CUT

TOUGH AND HIGH GRASS

Before cutting, particularly in long grass, examine the ground and remove stones etc. If grass is particularly tough, go slowly in order to keep the engine revs up.

USING THE TRIMMER ON SLOPES

Exercise extreme caution while using this trimmer on slopes.

A slope is defined as uneven terrain on which you, the operator, are unable to maintain your feet firmly on level ground in order to use the trimmer.

Do not use this trimmer on slopes which are wet or too steep to maintain a firm footing

Always use heavy shoes when using this trimmer.

Never push the trimmer up the slope.

Always keep the trimmer below you on the slope.

COMPLETION OF TRIMMING

Having completed the trimming, do not stop the engine but follow this procedure.

1. Close fuel tank air vent screw.
2. As soon as the engine begins to fade, tilt the trimmer towards you.
3. After the engine has stopped, move stop/start switch to stop position, disconnect the spark plug lead.
4. Clean trimmer. Use a flat piece of thin wood to remove grass adhering to underside of deck.

MAINTENANCE OF YOUR TRIMMER

ON COMPLETION OF TRIMMING

Clean grass from under deck. Remove any leaves or grass cuttings from around the engine cooling fins, carburettor and impeller air openings.

AIR FILTER MAINTENANCE

- Never run the engine without a filter or with a dirty filter. This will greatly reduce engine efficiency and lead to engine damage.
- Your trimmer is fitted with a turbo filter the maintenance for which is as follows:-
When the engine performance drops (e.g. difficult starting or loss of revs) check the air cleaner.

1. Remove the two screws (4). Take off the filter cover (1).
2. Remove the two filters (5) and (6). Clean inside the filter cover thoroughly.
3. Shake or tap the thick filter (5) to remove any dirt or dust.
4. Replace the thin filter (6) if it is contaminated with dust. **DO NOT OIL THE FILTERS.**
5. Install the thick filter (5) in the filter cover (1). Place the thin filter (6) on top. **DO NOT CREASE THE FILTERS.**
6. Clean the filter body (7) with a small brush. Replace the filter cover (1) and the two screws (4).
7. **DO NOT REMOVE** the cap (2) or screws (3) unless there is visual evidence of grass or dirt.

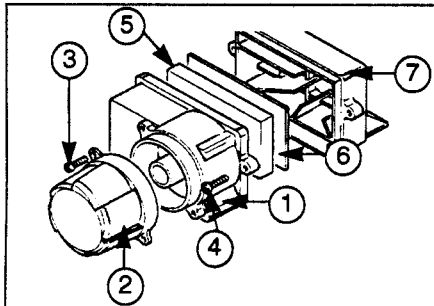

SPARK PLUG

An oily or carboned spark plug makes starting difficult and decreases the efficiency of the engine. Periodically remove the spark plug and clean and adjust when necessary. Gap setting 0.30" (0.8 mm). Do not remove spark plug when engine is hot. Do not sand blast the spark plug to clean it.

WINTER CARE

For trouble-free trimming next season, make sure that your trimmer is serviced immediately after the last cut of the year, as follows:-
When the engine is cold, drain all fuel from the tank and then run the engine until it stops. (Fuel left in the machine becomes stale and causes difficult starting). Thoroughly clean all external parts of the trimmer. Clean air filter (see air filter maintenance).
Inspect, clean and replace spark plug.
Do not replace spark plug lead.
Check and replace cutting lines.
Store the trimmer in a dry, damp-proof secure area out of the reach of children.

WINTER CARE

The cutting line is sharp, wear gloves and take care when handling it.
Check the cutting line frequently during use and on completion of trimming.
Removing the Cutting Line
Switch machine off and disconnect spark plug lead.
Push the line towards the centre of the cutting disc and carefully remove. See Fig 1.

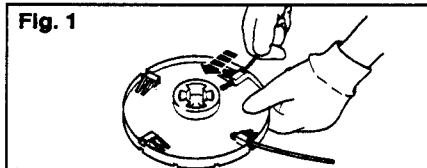

Renewing the Cutting Line

Holding the line with thumb and forefinger and using other thumb as a guide, curve around centre portion of the cutting disc (as illustrated in Fig 2) and thread through the hole on the rim of the cutting disc.

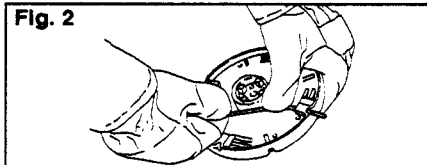

Carefully pull the line into place as illustrated in Fig. 3.

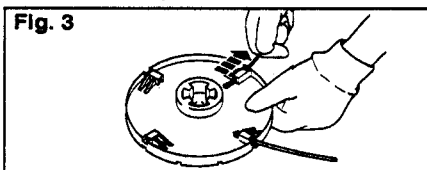

At all times the amount of line extending beyond the edge of disc should be of an even length. If there is a variation of more than half an inch between the four lengths of line replace immediately with four full new lengths. **Important:- Only fit four cutting lines at any one time**

HEIGHT ADJUSTMENT

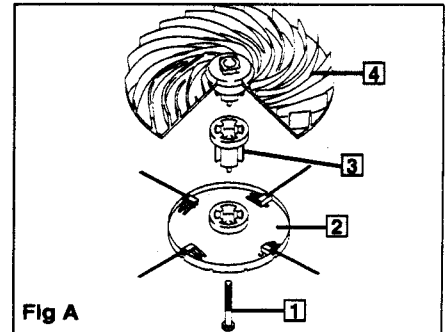

Fig A

1. Loosen bolt (1), using a 9/16 AF socket. Remove bolt (1), cutting disc (2) and spacer (3) (if fitted).
2. Carefully remove impeller from engine shaft.
3. Select required height of cut, (See Figs B, C, D & E) and replace any cutting lines required, ensuring that cutting line is fitted on correct side of cutting disc.
- **Important:- Cutting line must be on the side of the disc facing the grass when fitted.**
4. Replace impeller on to engine shaft ensuring that it is correctly located. Replace spacer (4) (if fitted), cutting disc (2) and bolt (1).
5. Secure assembly with bolt (1), making sure complete assembly is tight, (if in doubt, contact your service dealer).

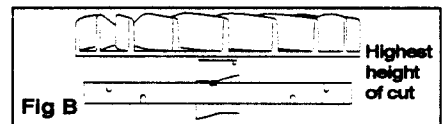

Fig B

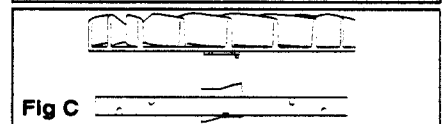

Fig C

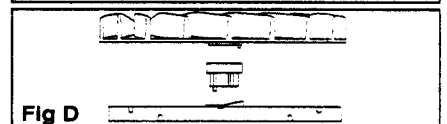

Fig D

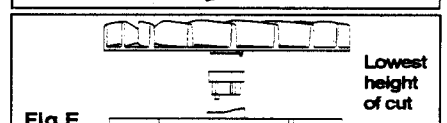

Fig E

FAULT FINDING HINTS

DIFFICULT TO START

Check that the start/stop switch is in the 'start' position. Ensure fuel tank cap air vent screw is open. Fuel mixture may be stale (e.g. long time since trimmer was used). Renew with fresh mixture. Check that correct amount of 2 stroke oil is being used in the fuel mixture. Check that the cutting disc is securely tightened.

ENGINE OVERHEATING

Check flow of air over cylinder.
Remove all grass and dirt.
Check correct fuel mixture.

POOR FLOTATION OR LACK OF POWER

Check correct fuel mixture is used.
Ensure underside of deck is clean.
Air filter may need cleaning (see air filter maintenance).
Ensure exhaust port on silencer does not have excessive build-up of carbon.
Remove disc/impeller and clean thoroughly between vanes.



EXCESSIVE VIBRATION

Check that the cutting disc is securely fastened and undamaged.
Tighten all external bolts and screws.
Check crankshaft - it may have bent.

WARRANTY

A full warranty statement is detailed on the service literature, and with the Tecumseh engine literature supplied with this product.