

J O N S E R E D S E R V I C E

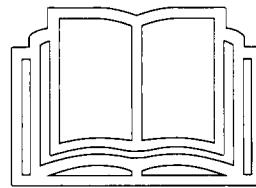
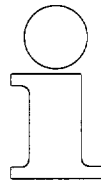

HP 36

Owner's manual

Read these instructions carefully and make sure you understand them before using the machine.

KEY TO SYMBOLS

Symbols



WARNING!
Risk of personal injury or damage to machine with incorrect use.



Read the instructions carefully and make sure you understand them before using the machine.



Always wear:

- Safety helmet
- Hearing protection
- Safety glasses or visor



- Drivers of the machine shall ensure that no one comes closer than 15 m during the work.
When several drivers are working within the same area the safety distance shall be at least 15 m.



Do not touch the cutting equipment without switching off the engine.

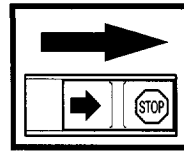

Switch off the engine by moving the stop switch to the STOP position before carrying out any checks or maintenance.

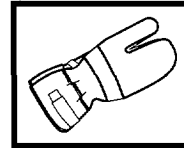

Always wear safety gloves.

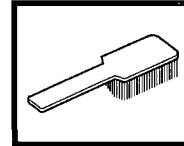

Regular cleaning is required.

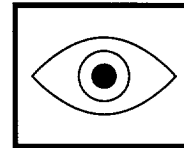

Visual check.



Safety glasses or a visor must be worn.

CONTENTS

Before using a new machine

Read the Operator's Manual carefully.

- Check the assembly and adjustment of the cutting equipment.
- Start the machine and check the carburettor settings.

IMPORTANT!

A too lean carburettor adjustment significantly increases the risk of an engine breakdown.

Insufficient care of the air filter will cause deposits on the spark plug resulting in starting difficulties.



WARNING!
Under no circumstances may the design of the machine be modified without the permission of the manufacturer. Always use genuine accessories. Non-authorized modifications and/or accessories can result in serious personal injury or the death of the operator or others.



WARNING!
The machine's cutting equipment must under no circumstances be connected to other hydraulic units than what it is designed for.



WARNING!
Only original cutting equipment must be connected to the hydraulic unit.

SYMBOL EXPLANATION

Symbols 2

CONTENTS

Before using a new machine 3

Contents 3

SAFETY INSTRUCTIONS

Personal safety equipment 4

The machine's safety equipment 4

Control, maintenance and service of the machine's safety equipment 6

Checking for wear on the cutting equipment 7

General safety instructions 7

General working instructions 9

Basic safety precautions 9

Basic clearing techniques 9

WHAT IS WHAT?

What is what on the machine? 10

ASSEMBLY

Connecting the hydraulic hose 11

Dismantling the hydraulic hose 11

Assembly of throttle handle 11

FUEL HANDLING

Petrol 12

Twostroke oil 12

Mixing 12

Fuelling 12

Hydraulic oil 13

START AND STOP

Cold engine 13

Warm engine 13

Stop 13

Start 14

Fitting the harness 14

Removing the harness 14

Quick release in case of hazard 14

MAINTENANCE

Carburettor 15

Air filter 16

Muffler 16

Spark plug 16

Cooling system 17

Replacing the cutter 17

Sharpening of the pressure shears 17

Replacing the cutting edge 17

Sharpening of the scissor shears 17

Adjustment of the ball joint 17

Maintenance schedule 18

TECHNICAL DATA

HP 36 20

SAFETY INSTRUCTIONS

Personal safety equipment

IMPORTANT INFORMATION

- **Incorrect or careless use of a pruner can turn in into a dangerous tool that can cause serious or even fatal injury. It is extremely important that you read and understand this manual.**
- **When using a pruner safety equipment approved by the appropriate authorities must be used. Personal safety equipment does not eliminate the risk of accidents, however, it can reduce the effects of an injury in the event of an accident. Ask your dealer for help when choosing safety equipment.**

GLOVES

Gloves should be worn when necessary, e.g. when assembling cutting equipment.

HELMET

A helmet should be worn to eliminate headinjuries caused by downfalling branches.

EAR PROTECTION

Ear protection offering sufficient dampening effect should be used.

EYE PROTECTION

Blows from branches or other can damage the eyes.

SHOES OR BOOTS

Use anti-slip and sturdy footwear.

CLOTHING

Wear clothes made of a strong fabric and avoid loose clothing that can catch on shrubs and branches.

FIRST AID KIT

A first aid kit should always be easy to reach.

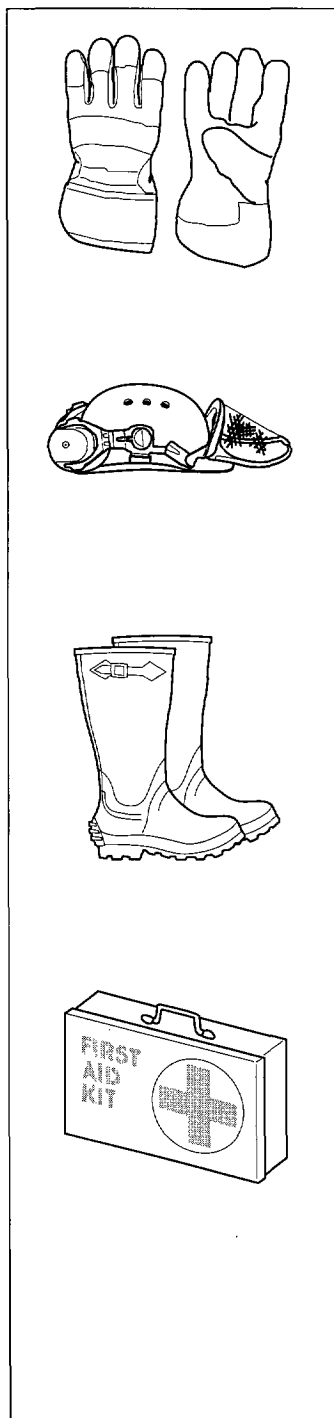

The machine's safety equipment

This section describes the machine's safety equipment, its function and how checks and maintenance are carried out to ensure that it operates correctly. (See the chapter "What is what" to locate where this equipment is positioned.)



WARNING!

Never use a machine with defective safety equipment. Follow the control, maintenance and service instructions described in this section.

1. Throttle trigger lock

The throttle trigger lock is designed to prevent the throttle from accidentally being engaged. When the trigger lock (A) is pressed into the handle (= when you hold the handle) the throttle (B) is released. When the grip on the handle is released the throttle and the throttle trigger lock return to their original positions. This take space via two independent return spring systems. This means that the throttle is automatically locked in its "idling" position.

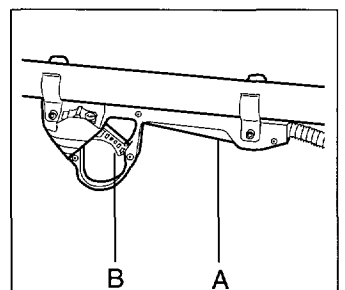

2. Stop switch

The stop switch should be used to stop the engine.

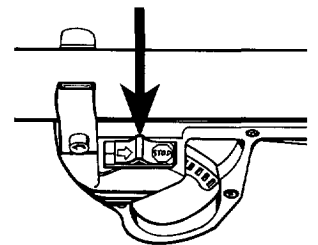

3. Emergency release

The harness is fitted with an emergency release. By pulling the red strap the hip and one shoulder belt release at the same time, and the harness and engine unit slide down to the ground.

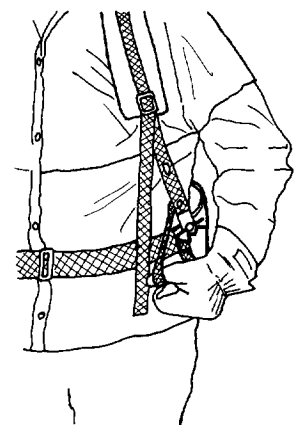

SAFETY INSTRUCTIONS

4. Vibration damping system

Your machine is equipped with a vibration damping system, which is designed to give as vibration-free and comfortable use as possible.

The machine's vibration system reduces the transfer of vibrations between the engine unit and the harness.

The harness is also well padded at the hip section and has wide shoulder belts to distribute the weight and vibrations.

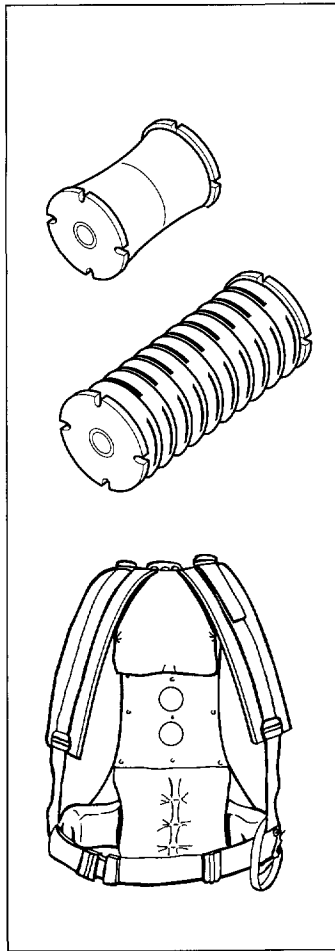

WARNING!

Over exposure to vibrations can result in blood-vessel or nerve injury to persons suffering with blood circulation problems. Seek medical attention if you experience physical symptoms that can be related to over exposure to vibrations. Examples of such symptoms are "numbness", lack of feeling, "tickling", "pricking", "pain", lack of or a reduction in normal strength, changes in the colour of the skin or its surfaces. These symptoms normally appear in the fingers, hands or wrists.

5. Silencer

The silencer is designed to give the lowest possible noise level and to direct the engine's exhaust fumes away from the operator.

The engine's exhaust fumes are hot and can contain sparks, which can lead to the outbreak of fire.

In countries that have a warm and dry climate the risk of fire is obvious. We have therefore fitted certain silencers with a spark arrest screen. Check if your silencer is fitted with this kind of screen.

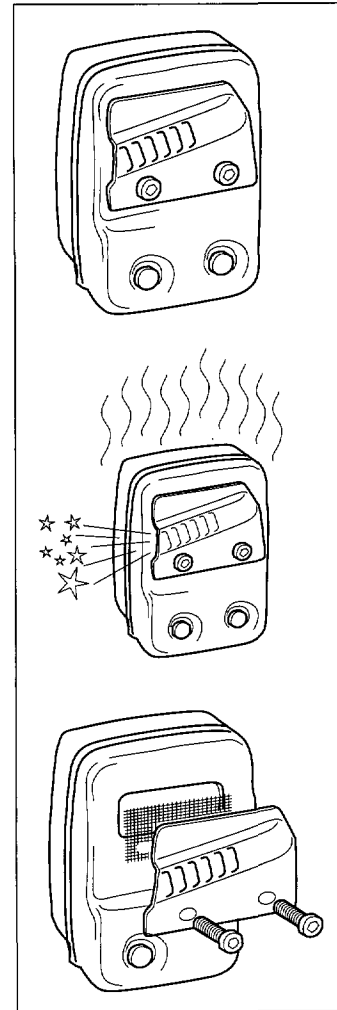

It is extremely important that the instructions for checking, maintaining and servicing the silencer are followed. (See the section "Control, maintenance and service of the machine's safety equipment")



WARNING!

During use and for some time after the silencer is very hot. Do not touch the silencer if it is hot!

6. Cutting equipment

The machine can be fitted with either pressure shears or scissor shears.

Make sure that the cutting equipment is not damaged by for example cutting steel wire or nails, or by force when releasing it after jamming.

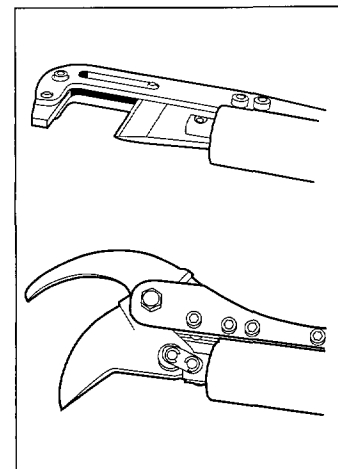

SAFETY INSTRUCTIONS

Control, maintenance and service of the machine's safety equipment

IMPORTANT INFORMATION

- All service and repairs to the machine require special training.
- This applies especially to the machine's safety equipment. If the machine does not meet any of the controls listed below you should contact your service workshop.
- The purchase of one of our products guarantees that professional repair and servicing will be carried out on it. If the point of purchase is not one of our servicing dealers, please ask for details of the closest service workshop.

1. Throttle trigger lock

- Check that the throttle is locked in the "idling position" when the throttle trigger lock is in its original position.
- Press in the throttle trigger lock and make sure it returns to its original position when released.
- Ensure that the throttle and throttle trigger lock move easily and that their return spring systems function.
- Start the machine and apply full throttle. Release the throttle and check that the cutting equipment stops and remains at a standstill. If the cutting equipment rotates with the throttle in the idling position then the carburettor's idling setting must be checked. See chapter "Maintenance".

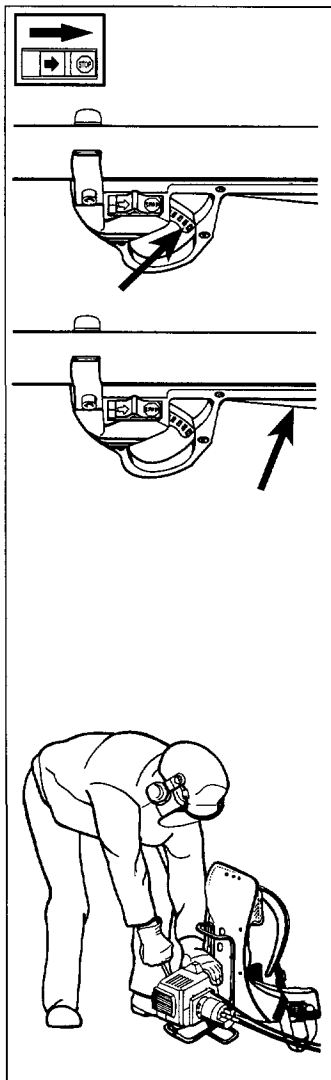

2. Stop switch

- Start the engine and make sure that the engine stops when the stop switch is moved to the stop position.

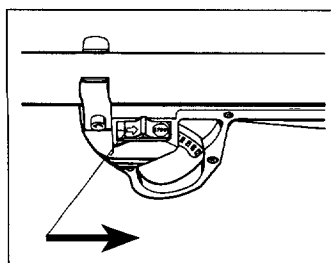

3. Vibration damping system

- Check the vibration damping elements regularly for material cracks and distortion.
- Check that the vibration damping elements are securely attached between the engine unit and the harness.

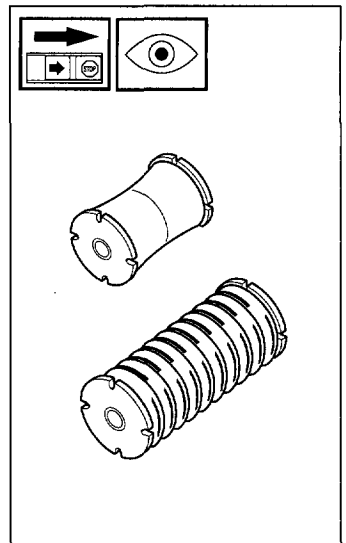

4. Silencer

- Never use a machine that has a defective silencer.
- Check regularly that the silencer is secure.
- If your silencer is fitted with a spark arrest screen then it should be cleaned regularly. A blocked screen leads to the engine overheating with serious damage as a result. Never use a silencer with a defective spark arrest screen.

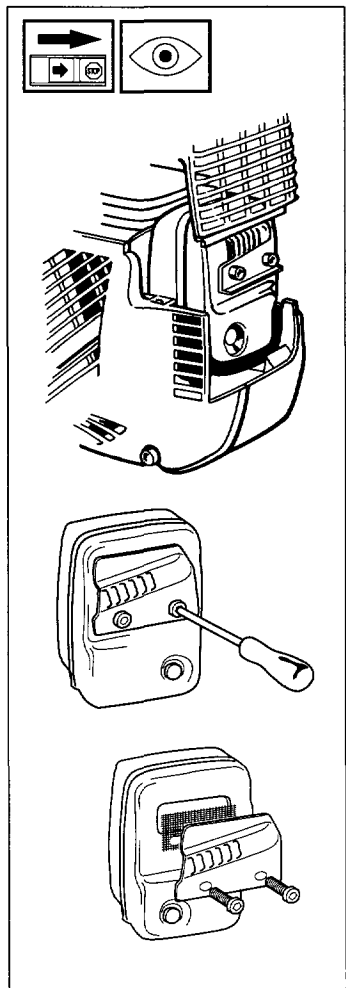

SAFETY INSTRUCTIONS

5. Cutting equipment

This section describes how through correct maintenance and through using the right type of cutting equipment you can:

- Obtain maximum cutting capacity.
- Increase the service life of the cutting equipment.

- A. Only use the cutting equipment we recommend!
- B. Keep the the cutting equipment well lubricated and maintained. Insufficient lubrication increases the wear of the shears.

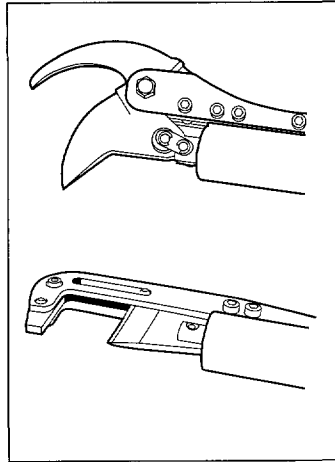



WARNING!
Never use a machine with defective safety equipment. The safety equipment should be maintained as described in this section. If your machine does not meet any of these controls you should contact your service workshop.



Checking for wear on the cutting equipment

Check the cutting equipment each time it is used for:

- Damage and wear to the shears.
- Damage and wear to the end-stop.
- Damage to the bearing (sissor shears).
- Damage to the guide slot and guide pins (pressure shears).
- Fracture or cracking on shears links to hydraulic cylinder (sissor shears).

See chapter "Maintenance" for measures taken.



WARNING!
Faulty cutting equipment increases the risk of accidents.

General safety instructions

IMPORTANT INFORMATION

- The machine is only designed for pruning trees.
- The only accessories to be used with the engine unit as a drive source are the cutting units we recommend.
- Never use the machine if you are tired, if you have consumed alcohol, or if you are taking medicines that can affect your sight, your judgement or the control of your body.
- Use personal safety equipment. See the section "Personal safety equipment".
- Never use a machine that has been modified so that it no longer corresponds with the original design.
- Never use a machine that is faulty. Follow the maintenance, control and service instructions in this Operator's Manual.

Some maintenance and service actions should be carried out by trained and qualified specialists. See the chapter "Maintenance".

SAFETY INSTRUCTIONS

A. Start

- Never start the engine unless the hydraulic oil has been replenished and the hydraulic hoses are connected. Running without hydraulic oil or without connected hoses can result in damage to the hydraulic system.
- Never start the engine indoors. Pay attention to the danger of inhaling toxic exhaust fumes.
- Make sure that there is no risk of people or animals coming in contact with the cutting equipment.

- Place the machine on the ground and make sure that the cutting equipment is not in contact with branches or stones.

Press the engine to the ground with the left hand (NOTE! Not with the foot). Grip the start handle with the right hand and slowly pull out until a resistance is felt (the start hooks engage). Now give a quick and strong pull.

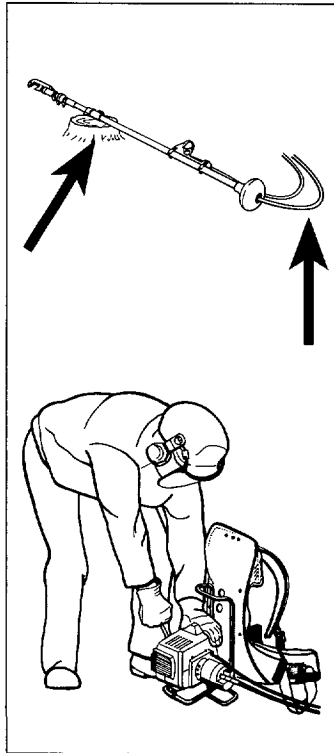

WARNING!

Starting with the start throttle function connected can give an uncontrolled activation of the cutting equipment.



WARNING!

Never touch the cutting equipment when the engine is running.

B. Fuel safety

- Never fill the machine while the engine is running.
- Provide good ventilation when filling or mixing fuel.
- Move the machine at least 3 m from the filling position before starting.
- Never start the machine:
 - a) If you have spilt fuel on it: Wipe up all spillage.
 - b) If you have spilt fuel on yourself or your clothes: Change your clothes.
 - c) If there is a fuel leak: Change damaged parts.Make regular checks for leakage from the fuel cap and the fuel supply pipes.

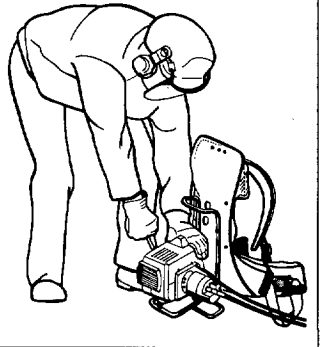
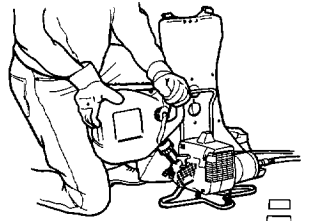

C. Storage

- Store the machine and fuel so that any leakage or fumes do not risk coming into contact with sparks or naked flames. For example, electric machines, electric motors, electrical switches/power switches, heaters or the like.
- When storing fuel approved containers intended for this purpose must be used.
- When storing the machine for long periods the fuel tank must be emptied. Contact your local petrol station to find out how to dispose of excess fuel.



WARNING!

Exercise great care when handling fuel. Bear in mind the risk of fire, explosions and inhaling fumes.

SAFETY INSTRUCTIONS

General working instructions

IMPORTANT INFORMATION

- This section takes up the basic safety precautions for working with the pruner.
- If you encounter a situation where you are uncertain how to proceed you should ask an expert. Contact your dealer or your service workshop.
- Avoid all usage which you consider to be beyond your capability.

Basic safety precautions

1. Observe your surroundings:
 - To ensure that people, animals or other things cannot affect your control of the machine.
 - To ensure that the above mentioned do not come into contact with the cutting equipment or objects that can be thrown by the cutting equipment.



WARNING!
Never use a machine without the possibility of calling for help in the event of an accident.

2. Avoid usage in un-favourable weather conditions. For example, thick fog, heavy rain, strong winds or extreme cold, etc. To work in bad weather conditions is tiring and can create dangerous circumstances, e.g. slippery surfaces.
3. Make sure you can walk and stand safely. Look out for any obstacles with unexpected movement (roots, stones, branches, pits, ditches, etc). Take great care when working on sloping ground.
4. When moving over longer distances and transporting the engine should be stopped and the transport guard should be used.
5. Never put the machine down with the engine running unless you have good sight of it.
6. Never allow children to use the machine.

Basic clearing techniques

- Always carry out clearing and trimming at full throttle.
- Always drop to idling speed after each working operation. Longer periods running at full throttle without loading the engine can lead to serious engine damage.



WARNING!

Never stand immediately below a branch being cut. This can result in serious or even fatal injury.

Observe great care when working close to overhead power lines. Falling branches can result in short-circuiting.



WARNING!

Observe the applicable safety regulations for work in the vicinity of overhead power lines.

- When working with the cutting equipment at varying heights slide with the throttle handle on the shaft. Keep your feet in position.
- Never cut in the knot seat (it speeds up waxing and counteracts rotting)!
- Search for the correct position in relation to the branch. Work with the shaft at an approx. 70° angle so that if possible the cut is at 90° to the branch.
- Do not work with shaft held straight out from the body (as with a fishing rod). This increases the strain of holding the cutting equipment.

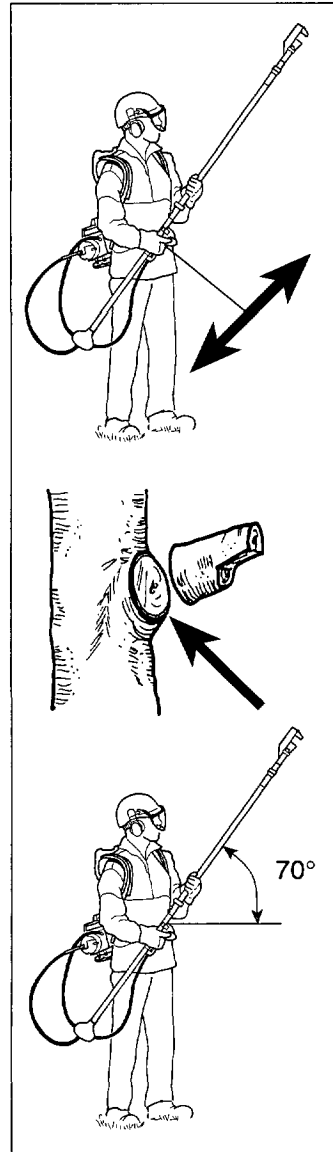

WARNING!

Never use the throttle without having a full view of the cutting equipment.

WHAT IS WHAT?

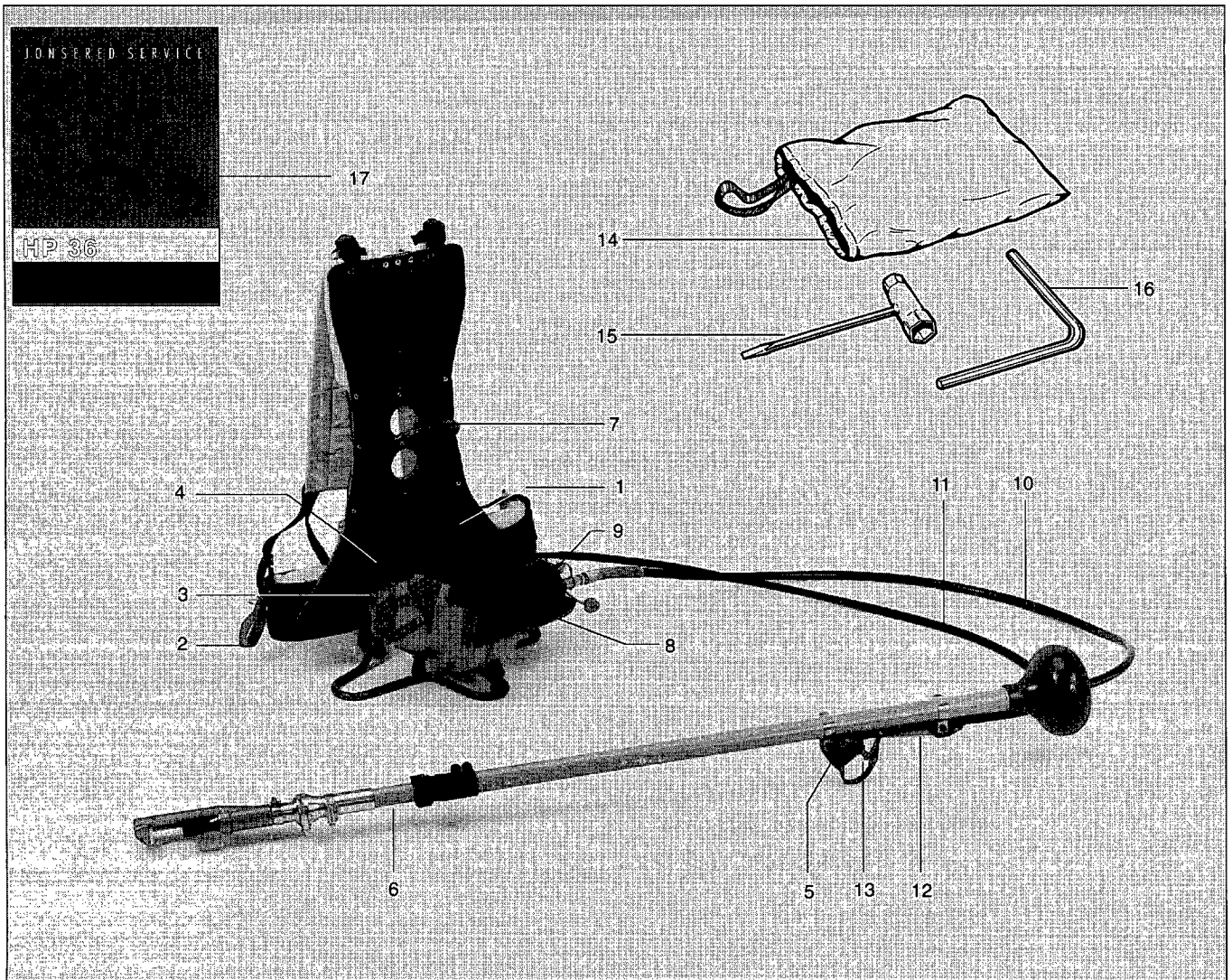

What is what?

- | | |
|------------------------------------|-------------------------------------|
| 1. Choke lever/start throttle lock | 10. High pressure hose |
| 2. Quick release | 11. Cable , ignition/throttle lever |
| 3. Fuel tank | 12. Throttle lever lock |
| 4. Start handle | 13. Throttle lever |
| 5. Stop contact | 14. Tool bag |
| 6. Telescopic shaft | 15. Combination key |
| 7. Hang-up loop | 16. Hex key |
| 8. Hydraulic oil tank/motor | 17. Owner's manual |
| 9. Quick-action couplings | |

ASSEMBLY



WARNING!

The cutting equipment of the pruning shears may under no circumstances be connected to another type of hydraulic pump than what it is constructed for.

Connecting the hydraulic hose

NOTE!

The quick couplings on the hydraulic hose and hydraulic oil tank should be clean and free from impurities.

Impurities in the hydraulic oil can cause break down of the hydraulic system.

Connect the quick coupling of the hydraulic hose with the quick coupling of the hydraulic tank.

1. Push in the locking sleeve on the quick coupling of the hydraulic tank inwards against the tank.
2. Thereafter push in the quick coupling of the hydraulic hose into the quick coupling of the oil tank as far as possible.
3. Release the locking sleeve.
4. Make sure the quick coupling connects securely.
5. Activate the extra lock of the quick-coupling by pushing it from the tank and then turning it approx. 90°.

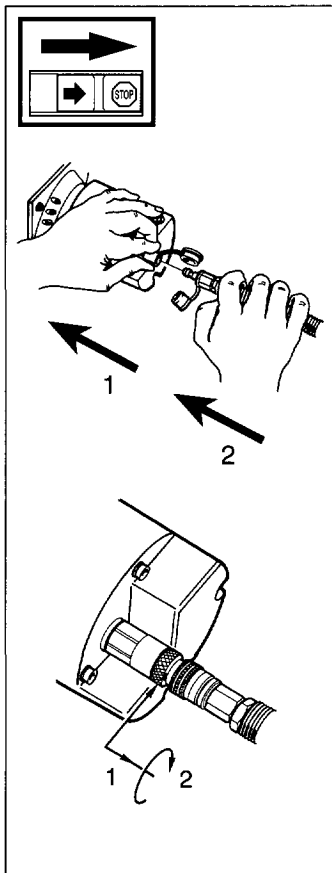

Dismantling the hydraulic hose

Release the extra lock by turning the ring until it snaps back to the hydraulic tank. Push in the lock sleeve and pull out the hose's quick-coupling.

NOTE!

Make sure the protecting plugs are mounted when the quick couplings are not connected.

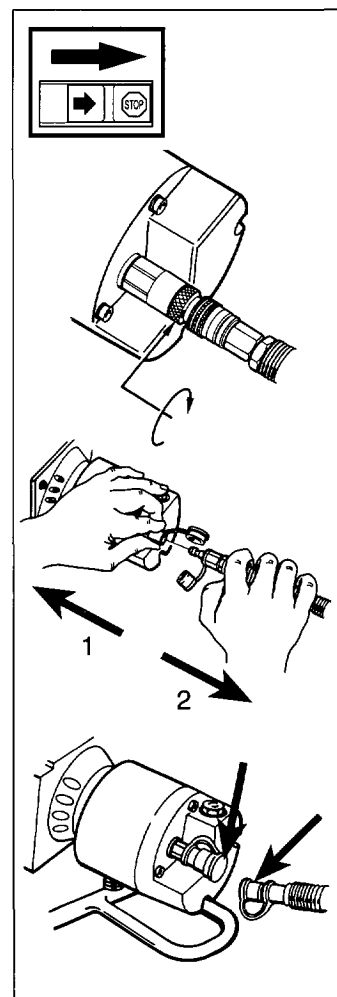

Assembly of throttle handle

Snap the throttle handle onto the shaft.

The throttle handle can be moved forwards or backwards to obtain a comfortable working position.

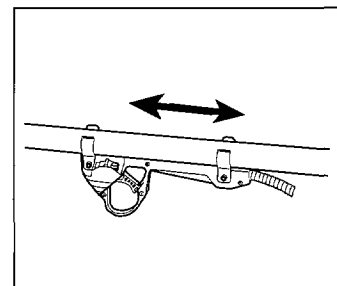

FUEL HANDLING

Fuel mix



WARNING!

The pruner is equipped with a twostroke engine and must always be run on a mixture of petrol and twostroke oil. It is important to accurately measure the amount of oil to be mixed to ensure that the correct mixture is obtained. When mixing small amounts of fuel, even small inaccuracies can drastically affect the ratio of the mixture. Always provide for good ventilation when handling fuel.

Petrol

- Use good quality unleaded or leaded petrol.
- The lowest octane recommended is 90. If you run the engine on a lower octane grade than 90, so-called knocking can occur. This gives rise to a high engine temperature, which can result in serious engine damage.
- For work with continuously high revs a higher octane rating is recommended.

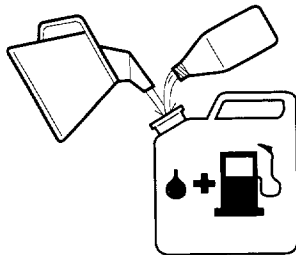

Twostroke oil

- For the best results use Jonsered twostroke oil. Mixing ratio 1:50 (2%).
- If Jonsered twostroke oil is not available, you may use another two-stroke oil of good quality that is intended for air cooled engines. Contact your dealer when selecting an oil. Mixing ratio 1:33 (3%) - 1:25 (4%).
- Never use twostroke oil intended for water cooled outboard engines, so-called outboard oil.
- Never use oil intended for four-stroke engines.

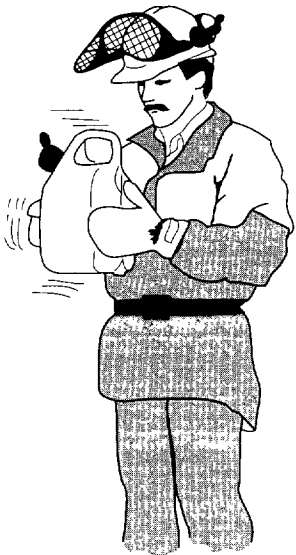

Mixing

- Always mix the petrol and oil in a clean container intended for fuel.
- Always start by filling half the amount of petrol to be used. Then add the entire amount of oil. Mix (shake) the fuel mixture. Add the remaining amount of petrol.
- Mix (shake) the fuel mixture thoroughly before filling the fuel tank.
- Do not mix more than approx. 2 month's supply of fuel.
- If the pruner is not used for some time the fuel tank should be emptied and cleaned.

Lit.	Lit.		
	2 % (1:50)	3 % (1:33)	4 % (1:25)
5	0,10	0,15	0,20
10	0,20	0,30	0,40
15	0,30	0,45	0,60
20	0,40	0,60	0,80

Fuelling



WARNING!

The following precautions reduce the risk of fire:

Do not smoke or place any sources of heat in the vicinity of the fuel.

Never refuel when the engine is running.

Open the fuel cap slowly when fuelling so that any over pressure is released slowly.

Tighten the fuel cap carefully after refuelling.

Always move the machine from the fuelling place before starting.

FUEL HANDLING – START AND STOP

- Clean around the fuel cap. Contamination in the tank can disrupt operations.
- Ensure that the fuel is well mixed by shaking the container before filling the tank.

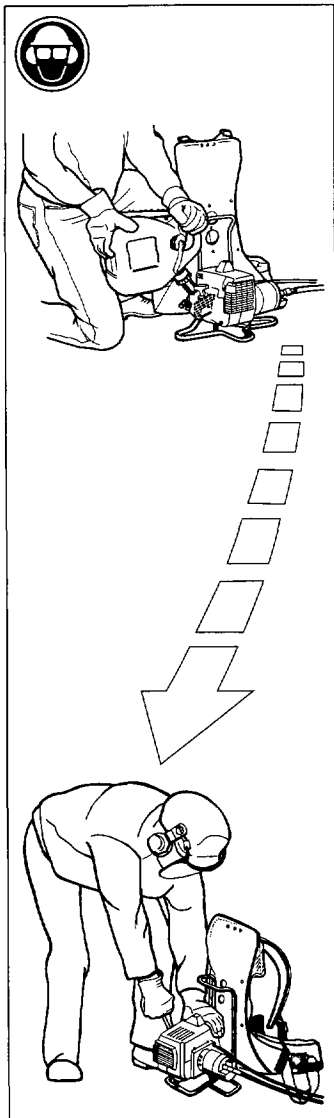

Hydraulic oil

Hydraulic oil ISO type Shell Tellus T32 is recommended at temperatures below +20°C.

Hydraulic oil ISO type Shell Tellus T45 is recommended at temperatures above +20°C.

The engine can also be run on vegetable or synthetic mineral oil.

CAUTION!

The oil's flash point must be greater than +160°C. Fill the hydraulic oil until its level is visible in the sight-glass. Check the level of the hydraulic oil each time you refuel.

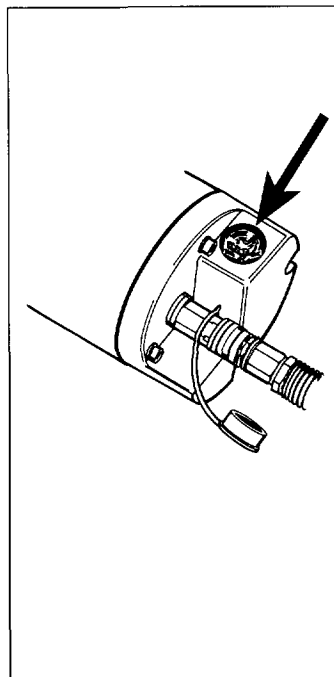

Start and stop



WARNING!

Do not start the engine without having mounted the hydraulic attachment. Otherwise the clutch can cause personal injury.

- Always move the machine from the place of filling before starting.
- Place the machine on a solid surface. Check that you stand steady when starting the engine.
- Make sure no unauthorized persons are within the working area.

NOTE!

Never start the engine without hydraulic oil in the oil tank and checking that the hose is connected. Running without hydraulic oil or with the hose not connected can cause a breakdown in the hydraulic system.

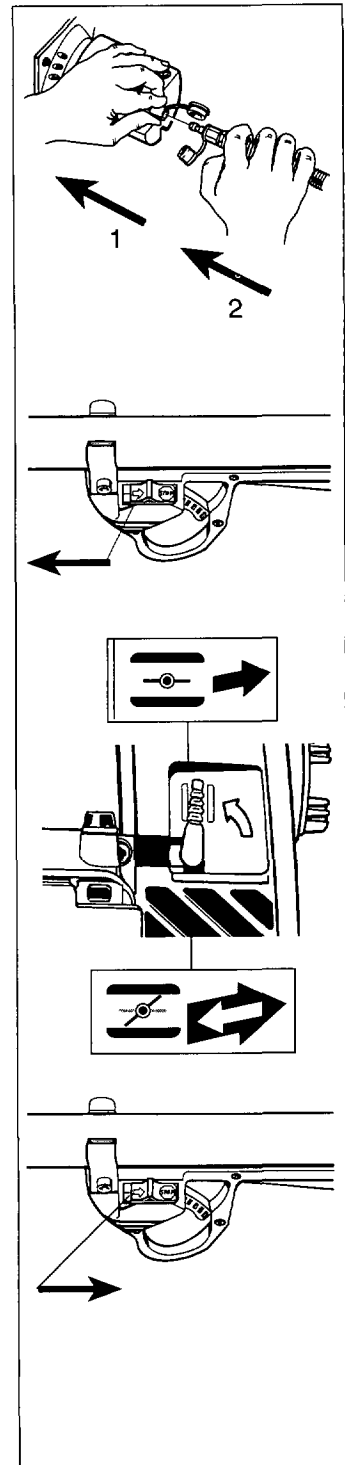

Cold engine

IGNITION:

Set the stop switch in start position.

CHOKE:

Set the choke lever in the choke position.

Warm engine

Use the same procedure as for the cold engine but do not set the choke lever in the choke position.

Start throttle is obtained by first moving the choke lever to the choke position and then back to the initial position.

Stop

The engine is stopped by switching the ignition off.

START AND STOP

Start

Press the machine body to the ground with the left hand. (NOTE: Not with the foot!) Grip the start handle, pull the start line slowly out with the right hand until a resistance is felt (the start hooks engage) and then make a quick and strong pull. Press in the choke control immediately when the engine fires and repeat the start procedure until the engine starts. When the engine starts give full throttle and the start throttle will automatically disconnect.

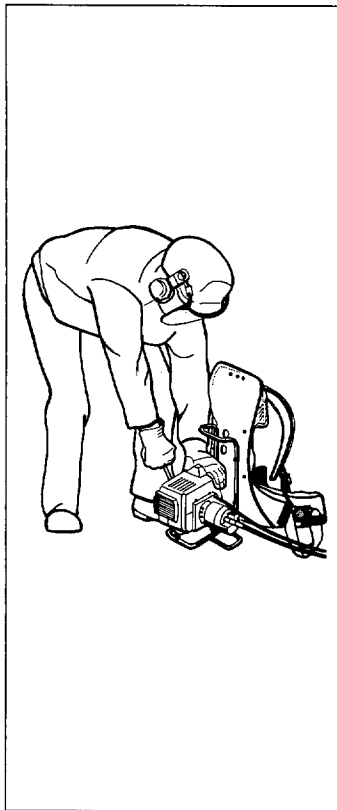

NOTE!

Do not pull the starter cord out completely and do not release the start handle from the fully drawn position. This can cause damage to the engine.

NOTE!

A new pruner being started for the first time may be run for maximum half a minute with repeated throttle movements.

After that, stop the engine and refill the hydraulic oil tank to correct level.

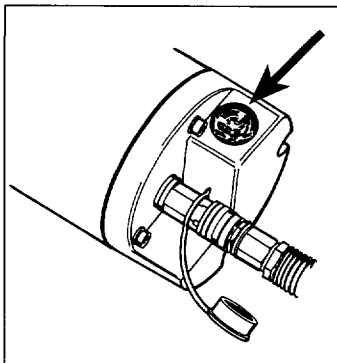

WARNING!

The hydraulic oil can during and after use be very hot. Avoid contact with the skin.

Fitting the harness

- Put on the harness with engine unit.
- Press together the hip belt's snap lock.
- Tension the hip belt so that it rests on the hips.
- Tension both shoulder belts so that the harness presses to the back.

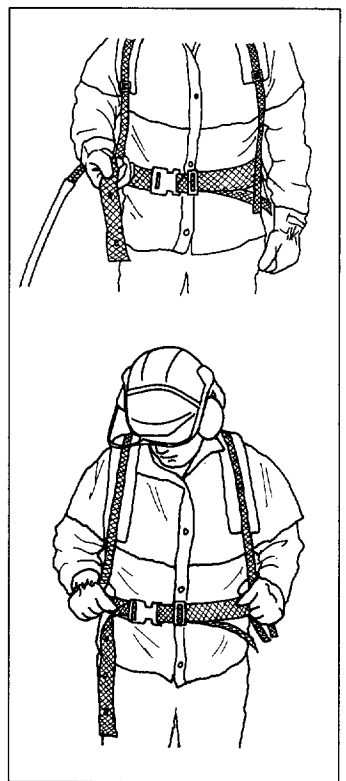

Removing the harness

- Switch off the engine.
- Release the hip belt's snap lock.
- Pull one arm out of the shoulder belt and lower the harness and engine unit to the ground with the other hand.



Quick release in case of hazard

- Pull out the red strap.
- The hip belt and one shoulder belt will be automatically released at the same time and the harness and engine unit will slide to the ground.

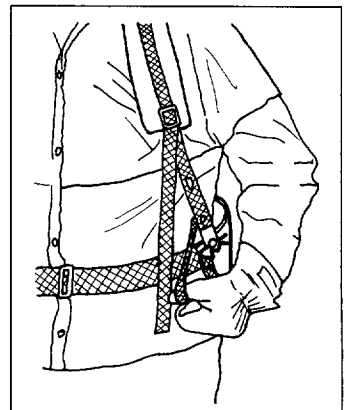

MAINTENANCE

Carburettor

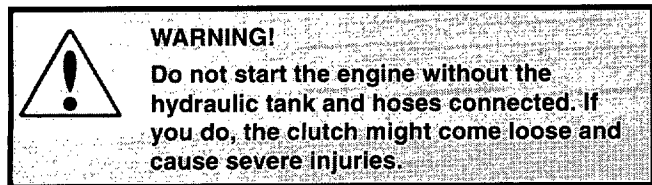

Functioning

- The carburettor governs the engine speed via the throttle trigger. In the carburettor, air/fuel is mixed. This air/fuel mixture is adjustable. If you want to take advantage of the maximum power output of the engine, the setting must be correct.
- The setting of the carburettor means that the engine is adjusted to local conditions, for example climate, altitude, petrol and type of two-stroke oil.
- The carburettor has three adjustment possibilities:
 - L = Low speed needle
 - H = High speed needle
 - T = Idle speed adjustment screw
- The fuel quantity required in proportion to the airflow the throttle trigger position allows is adjusted by means of the L- and H-needles. Turning the needles clockwise gives a leaner fuel mixture (less fuel), turning them counter-clockwise gives a richer fuel mixture (more fuel). A lean mixture gives higher rpms and a rich one lower rpms.
- The idling speed screw (T) regulates the position of the throttle lever in the idling speed position. Turning the idling speed screw clockwise gives a higher idling speed, turning it counter-clockwise gives a lower idling speed.

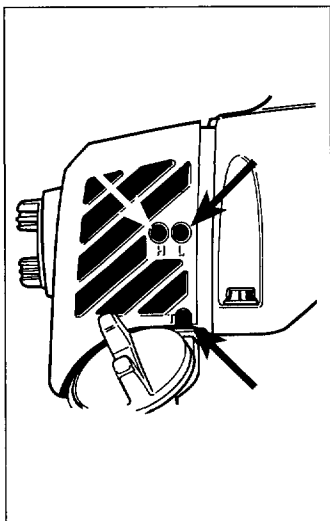

Basic setting

The carburettor is adjusted to a basic setting at the factory. The basic setting is richer than the optimum setting and shall be maintained during the first working hours. Thereafter, do the final setting of the carburettor. The basic setting can vary between:

H = 3/4 - 1 turn

L = 3/4 - 1 turn

The engine cannot be raced since the cutter head's blade goes against the stop and the engine is braked. The engine has max. revs when loaded. The high revs needle H shall not be changed from the basic setting (3/4-1 revs open). If there are a lot of exhaust fumes from the silencer at the same time as the engine splutters a lot then the setting is too rich. Turn the H needle clockwise until the setting sounds right.

NOTE!

A specialist should be engaged for optimal setting.

Fine-adjustment of idling T

Adjustment of the idling speed is done with the screw marked T.

The correct setting of the idling revs (approx. 2500 rpm) is when the engine runs smoothly in all positions.

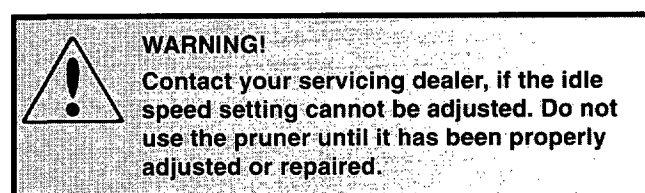

MAINTENANCE

Air filter

The air filter must be regularly cleaned from dust and dirt in order to avoid:

- Carburettor malfunctions
- Starting problems
- Engine power reduction
- Unnecessary wear on the engine parts
- Abnormal fuel consumption

Cleaning/change

Clean the filter after 25 hours or more regularly if operating conditions are exceptionally dusty.

Dismantle the air filter cover and remove the air filter. Wash in clean, warm soapy water.

Ensure that the filter is dry before refitting.

An air filter used for a long period of time can never be cleaned completely.

Therefore it is necessary to replace the filter from time to time with a new filter.

A damaged air filter must always be replaced.

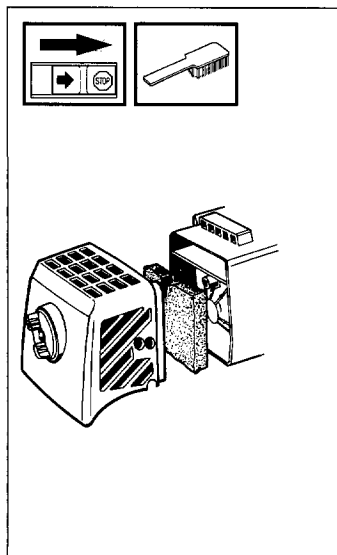

Muffler

The muffler is designed in order to reduce the noise level and to direct the exhaust gases away from the operator. The exhaust gases are hot and can contain sparks, which may cause fire if directed against dry and combustible material.

Some mufflers are equipped with a special screen. If your saw has this type of muffler, you should clean the screen at least once a week. This is done with a wire brush. The screen must be replaced, if damaged. The engine will be overheated, if the screen is clogged. This results in damage on the cylinder and the piston.

CAUTION!

Never use a pruner with a clogged or defective muffler.

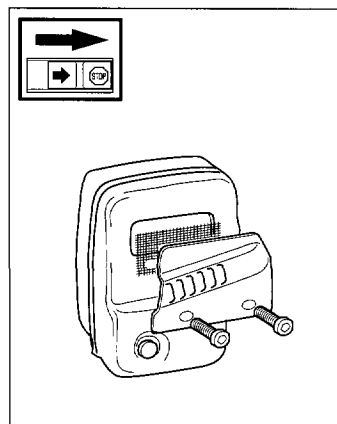

Spark plug

The spark plug condition is influenced by:

- An incorrect carburettor setting.
- Wrong fuel mixture (too much oil in the oil).
- A dirty air filter.

These factors cause deposits on the spark plug electrodes, which may result in malfunction and starting difficulties.

If the engine is low on power, difficult to start or runs poorly at idling speed, always check the spark plug first.

If the spark plug is dirty, clean it and check the electrode gap. Readjust if necessary. The correct gap is 0.5 mm (.020"). The spark plug should be replaced after about one month or earlier if the electrodes are badly eroded.

IMPORTANT! Always use the recommended spark plug type. Wrong type may ruin the piston/cylinder.

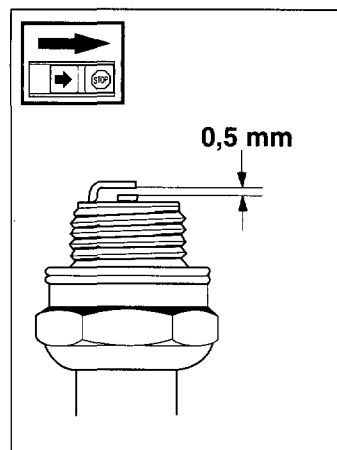

MAINTENANCE

Cooling system

To maintain as low an operating temperature as possible the engine is equipped with a cooling system.

The cooling system consists of:

1. An air intake on the starter unit.
2. Cooling fins on the flywheel.
3. Cooling fins on the cylinder.
4. Cylinder cover (leads cold air onto the cylinder).

Clean the cooling system using a brush at least once a week, in difficult conditions more often.

A dirty or blocked cooling system leads to the engine overheating resulting in damage to the cylinder and piston.

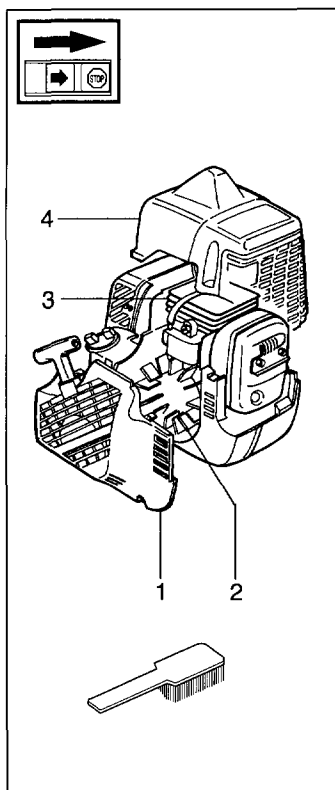

Replacing the cutter

1. Dismantle the cutter by pressing out the tubular pins (A) with a suitable drift.
2. Dismantle the tailstock by pressing out the tubular pin (B) with a suitable drift and the screw (C).
3. Fit in the reverse order.

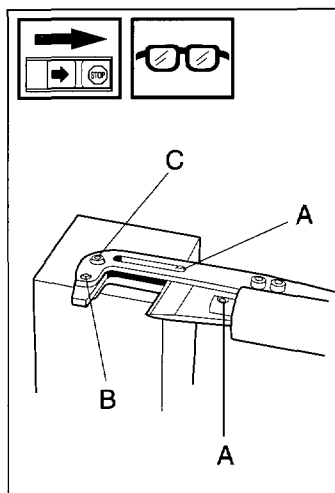

NOTE!

Use a support under the cutter when pressing out the pins to avoid skewing.

Sharpening of the pressure shears

With this type of cutting equipment both sides of the cutter should be filed or ground to the correct sharpness. It is important that both sides have the same finish.

Use a float-cut file or a whetstone.

If the cutter is heavily worn or damaged it should be dismantled and ground.

Replacing the cutting edge (scissors)

1. Dismantle the screw (A) and lock ring (B) with the accompanying bearing tap.
2. Dismantle the cutter's bearing sleeve. Let the screw remain in the thread in the sleeve and press out the sleeve with a suitable drift and hammer.
3. Check that the cutter can move freely by pressing it by hand to the tailstock. It should return by its own force to fully open position.

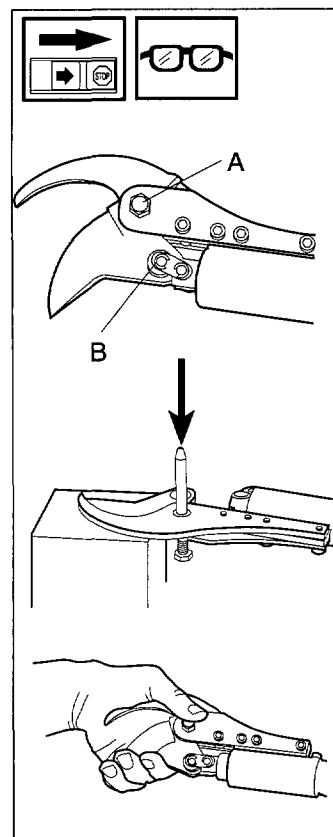

Sharpening of the scissor shears

With this type of cutting equipment only one side of the cutter (the outer edge) shall be sharpened.

Use a float-cut file or a whetstone.

If the cutter is heavily worn or damaged it should be dismantled and ground.

Adjustment of the ball joint



WARNING!

The engine must not be running during adjustment.

The fixture for the cutting tool is provided with a ball joint so that it is easy to change the cutting angle during work.

It is important the joint round the ball joint is correctly adjusted.

Tension the screw for a more rigid ball joint.

Release the screw for a more flexible ball joint.

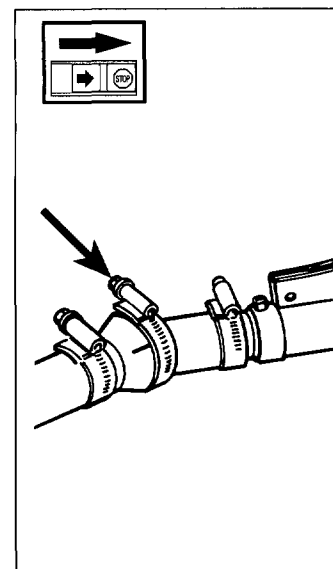

MAINTENANCE

Maintenance schedule

Below follows some general maintenance instructions.

If you need further information please contact your service workshop.

Daily maintenance

1. Clean the outside of the machine.
2. Check that the harness is undamaged.
3. Make sure the throttle trigger lock and the throttle function correctly from a safety point of view.
4. Check that the stop switch functions.
5. Check that the shears do not move when idling.
6. Clean the air filter. Replace if necessary.
7. Check hoses and hose connections for damage and wear.
8. Check the cutting equipment for damage to the cutter (cracking), the condition of the stop, and oil leakage.
9. Check that all nuts and screws are tightened.

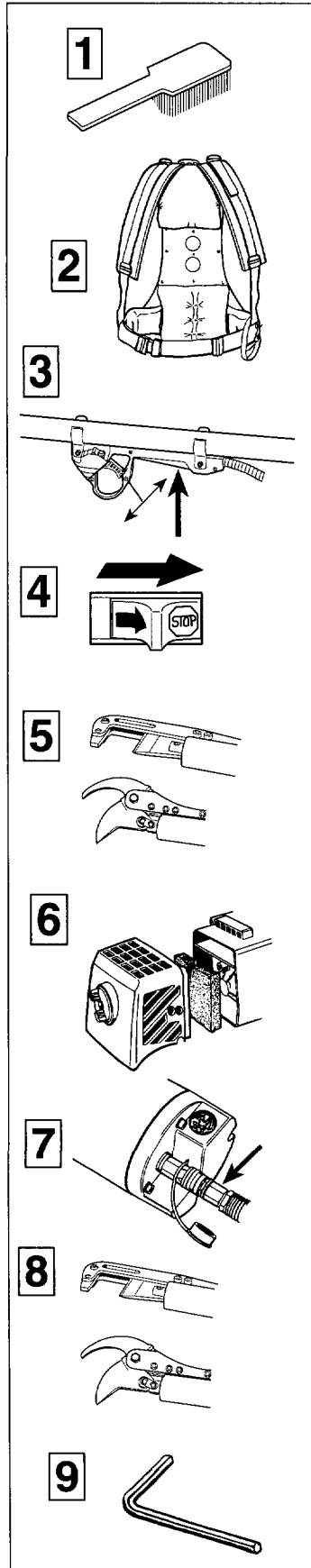

Weekly maintenance

1. Check the starter, the starter cord and the return spring.
2. Make sure that the vibration damping elements are not damaged.
3. Clean the outside of the spark plug. Remove and check the electrode gap. Adjust the gap to 0.5 mm or change the spark plug.
4. Clean the cooling fins on the flywheel.
5. Clean or replace the spark arrest screen on the silencer.
6. Clean the carburettor area.
7. Clean the cooling fins on the cylinder and check that the air intake in the starter unit is not blocked.
8. Clean the air filter.

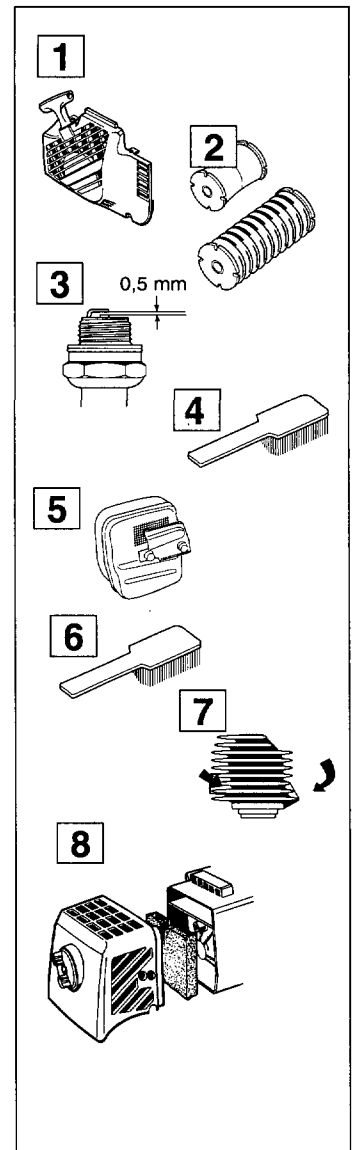

MAINTENANCE

Monthly maintenance

1. Clean the fuel tank using petrol.
2. Clean the carburettor and the area surrounding it.
3. Clean the fan and the area around it.
4. Check the fuel filter and the fuel pipe, replace if necessary.
5. Check all cables and connections.
6. Check the clutch, clutch springs and the clutch drum with regard to wear. Replace if necessary.
7. Change the spark plug.
8. Clean the inside of the hydraulic tank.

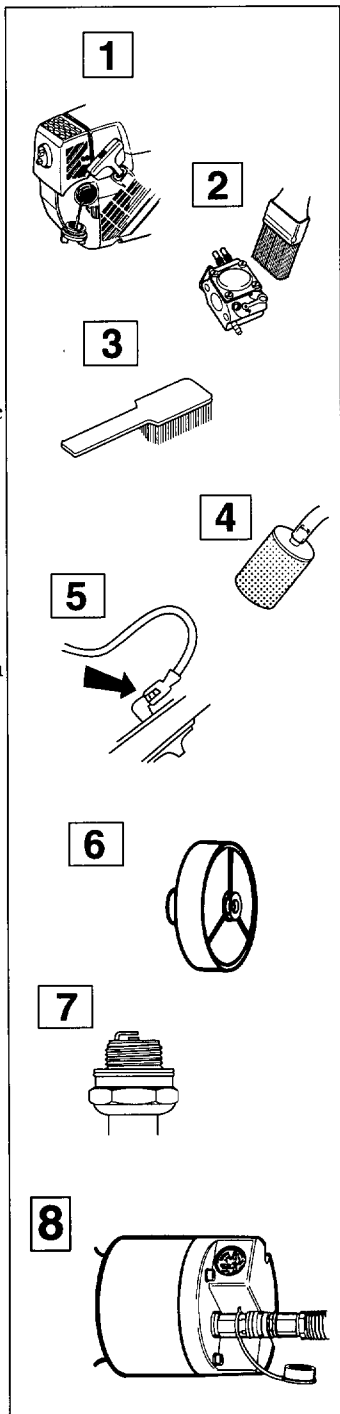

TECHNICAL DATA

Technical data

Engine

Cylinder capacity, cm ³	36.3
Cylinder bore, mm	38.0
Stroke, mm	32.0
Idling speed, rpm	2.500
Max. engine output, acc. to. ISO 8893	1,3 kW/8000 r/min

Hydraulic transmission

Hydraulic pump, capacity, cm ³ /rev	0.9
Working pressure, high pressure hose, bar	110
Flow, l/min	3-9.9

Ignition system

Manufacturer/type of ignition system	Phelon CD
Spark plug	Champion RCJ 7Y
Electrode gap, mm	0.5

Fuel/oil system

Manufacturer/type of carburettor	Walbro/WT 235
Volume, fuel tank, litre	0.60
Volume, hydraulic oil tank, litre	0.42

Weight

Engine unit without cutting equip., kg	7.7
--	-----

Noise levels

Noise output measured with 9 microphones as per the parallelepiped method + noise level at ear. The value for cutting is the mean value for repeated "imaginary cuttings" during one measurement cycle of 10 seconds/microphone.

With a weighting distribution between cutting/idling based on 10%/90% the final result becomes:

Weighted noise output $L_{w \text{ weighted}}$, dB(A) 92

Weighted noise pressure $L_{p \text{ weighted}}$, dB(A) 73

Vibration levels

Weighted acceleration total as per weighted filter ISO 7505.

Measurement point on back plate

100 mm from top edge

idling/cutting revs, m/s² 2,3/2,5

50 mm from bottom edge

idling/cutting revs, m/s² 2,8/2,8

Shaft idling/cutting revs, m/s² 0,3/0,3

Cutting equipment

Shaft length, max, m 2 and 4

Weight, kg 2.2