

# RS 51

## Operator's manual



Please read these instructions carefully and make sure you understand them before using the machine.

# SYMBOL EXPLANATION

## Symbols



**WARNING!** Clearing saws, brush cutters and trimmers can be dangerous!  
Careless or incorrect use can result in serious or fatal injury to the operator or others.



Read through the Operator's Manual carefully and understand the content before using the machine.



Always use

- A protective helmet
- Ear protection
- Approved protective glasses or visor

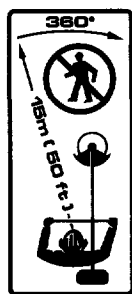

- The operator of the machine must ensure that no one comes within a 15 metre radius while working. When several operators are working within the same area a safety distance of at least a double tree length, however at least 15 metres, must be observed.



- Max. speed of output axle, 7800 rpm



- Beware of thrown objects.



- Only intended for the trimmer head.

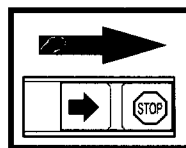

Checks and/or maintenance should be carried out with the engine switched off, with the stop switch in the STOP position.

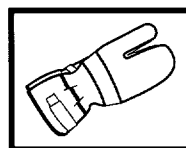

Always wear approved protective gloves.

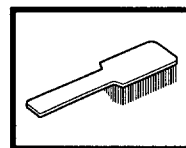

Regular cleaning required.

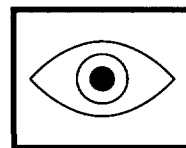

Ocular control.



Approved protective glasses or visor must always be used.

# CONTENTS

## Before using a new machine

- Read the Operator's Manual carefully.
- Check the assembly and adjustment of the cutting equipment. See page 18.
- Start the machine and check the carburettor settings. See page 24.

**IMPORTANT!** A too lean carburettor adjustment significantly increases the risk of an engine breakdown. Insufficient care of the air filter will cause deposits on the spark plug resulting in starting difficulties.



**WARNING!**  
Under no circumstances may the design of the machine be modified without the permission of the manufacturer. Always use genuine accessories. Non-authorized modifications and/or accessories can result in serious personal injury or the death of the operator or others.



### WARNING

The engine exhaust from this product contains chemicals known to the State of California to cause cancer, birth defects or other reproductive harm.

## List of contents

### SYMBOL EXPLANATION

Symbols ..... 2

### CONTENTS

Before using a new machine ..... 3

List of contents ..... 3

### SAFETY INSTRUCTIONS

Personal protective equipment ..... 4

The machine's safety equipment ..... 4

Control, maintenance and service of the machine's safety equipment ..... 7

Cutting equipment ..... 10

General safety instructions ..... 11

General working instructions ..... 12

Basic clearing techniques ..... 13

### WHAT IS WHAT?

What is what on the clearing saw? ..... 17

### ASSEMBLY

Assembling the handlebars ..... 18

Transport position, handlebars ..... 18

Assembly of the blade guard and blade ..... 19

Assembly of the trimmer head (Autohead) ..... 19

Assembly of the trimmer head (Polytrim head) ..... 20

Assembly of the blade and trimmer head ..... 20

Assembly of the trimmer head (Trimmy SII) ..... 20

Adjusting the harness and clearing saw ..... 21

### FUEL HANDLING

Fuel mixture ..... 22

Fuelling ..... 22

### START AND STOP

Control before starting ..... 23

Start and stop ..... 23

### MAINTENANCE

Carburettor ..... 24

Silencer ..... 25

Cooling system ..... 25

Air filter ..... 25

Angle gear ..... 25

Spark plug ..... 26

Sharpening the blade ..... 26

Maintenance schedule ..... 26

### TECHNICAL DATA

RS 51 ..... 28

# SAFETY INSTRUCTIONS

## Personal protective equipment

### IMPORTANT INFORMATION

- **Incorrect or careless use of a clearing saw, brushcutter or trimmer can turn it into a dangerous tool that can cause serious or even fatal injury to the operator or others. It is extremely important that you read and understand the content of this manual.**
- **When using a clearing saw, brushcutter or trimmer, protective equipment approved by the appropriate authorities must be used. Personal protective equipment does not eliminate the risk of accidents, however, it can reduce the effects of an injury in the event of an accident. Ask your dealer for help when choosing protective equipment.**

### HELMET

A helmet should be worn if trees to be cleared are higher than 2 metres.

### EAR PROTECTION

Ear protection offering sufficient dampening effect should be used.

### EYE PROTECTION

Blows from branches or objects thrown by the rotating cutting equipment can damage the eyes.

### GLOVES

Gloves should be worn when necessary, e.g., when assembling cutting equipment.

### BOOTS

Use anti-slip and sturdy footwear.

### CLOTHING

Wear clothes made of a strong fabric and avoid loose clothing that can catch on shrubs and branches.

### FIRST AID KIT

A first aid kit should be carried by operators of clearing saws, brushcutters or trimmers.

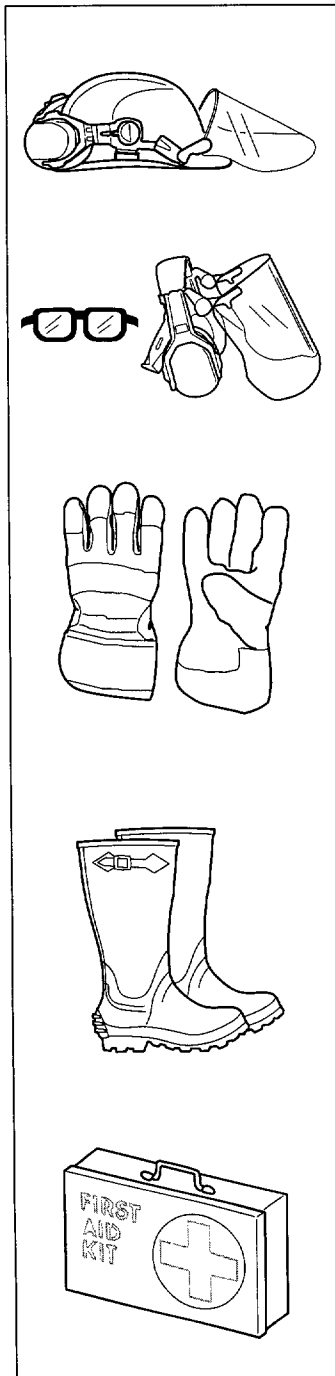

## The machine's safety equipment

This section describes the machine's safety equipment, its function and how checks and maintenance are carried out to ensure that it operates correctly. (See the chapter "What is what" to locate where this equipment is positioned on your machine.)



### WARNING!

**Never use a machine with defective safety equipment. Follow the control, maintenance and service instructions described in this section.**

### 1. Throttle trigger lock

The throttle trigger lock is designed to prevent the throttle from accidentally being engaged. When the trigger lock (A) is pressed into the handle (= when you hold the handle) the throttle (B) is released. When the grip on the handle is released the throttle and the throttle trigger lock return to their original positions. This takes place via two independent return spring systems. This means that the throttle is automatically locked in its "idling" position.

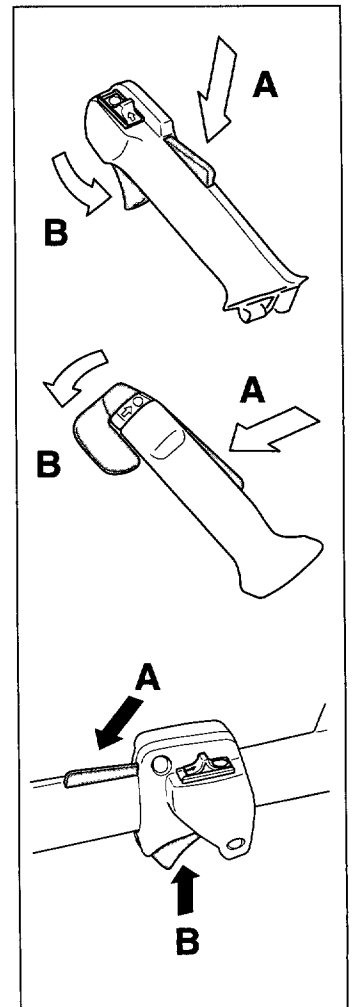

# SAFETY INSTRUCTIONS

## 2. Stop switch

The stop switch should be used to stop the engine.

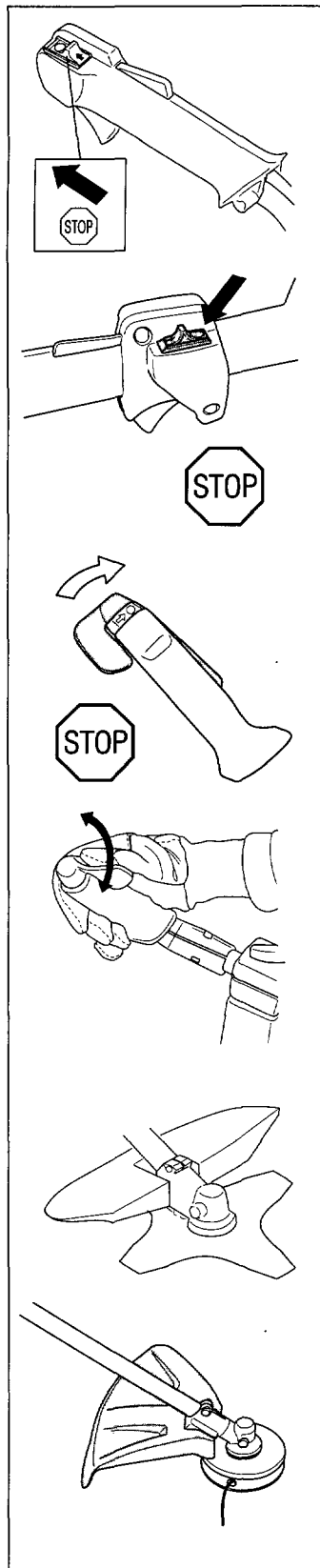

## 3. Cutting attachment guard

This guard is intended to prevent objects from being thrown towards the operator and to protect the operator from unintentional contact with the cutting attachment.

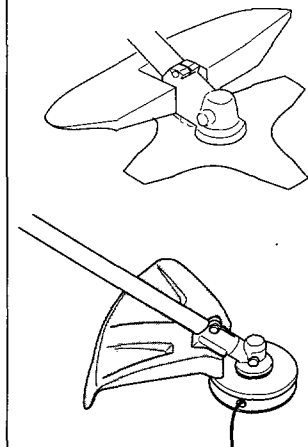

## 4. Vibration damping system

Your machine is equipped with a vibration damping system, which is designed to give as vibration-free and comfortable use as possible.

The use of blunt or incorrect cutting equipment (the wrong type or incorrectly sharpened, see the section "Sharpening the blade") increases the level of vibration.

The machine's vibration damping system reduces the transfer of vibrations between the engine unit/cutting equipment and the machine's handles. The engine body including the cutting equipment is suspended on the handlebar system via a vibration damping element.

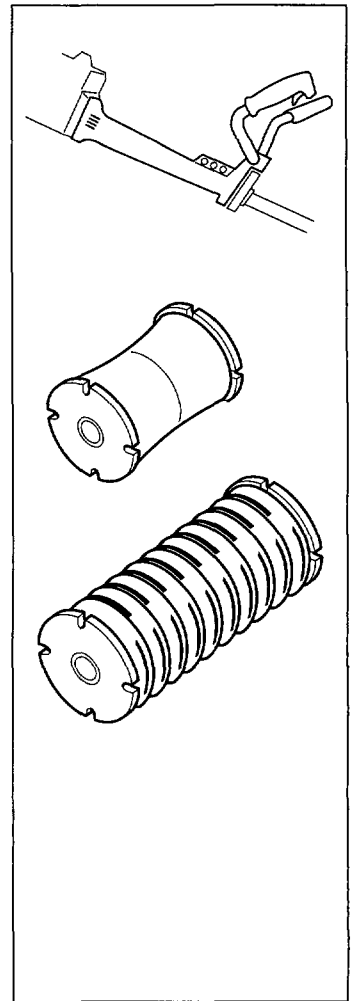

### WARNING!

Over exposure to vibrations can result in blood-vessel or nerve injury to persons suffering with blood circulation problems. Seek medical attention if you experience physical symptoms that can be related to over exposure to vibrations. Examples of such symptoms are "numbness", lack of feeling, "tickling", "pricking", "pain", lack of or a reduction in normal strength, changes in the colour of the skin or its surfaces. These symptoms normally appear in the fingers, hands or wrists.



### WARNING!

Under no circumstances may the blade be used without the recommended blade guard fitted. Serious injury can be caused if the wrong or a defective blade guard is fitted. See the chapter "Technical data".

# SAFETY INSTRUCTIONS

## 5. Quick-release

There is an easily accessible, quick-release catch fitted to the chest as a safety precaution in the event of a fire in the engine or for any other situation that requires you to free yourself from the machine and harness. See the section "Adjusting the harness and clearing saw".

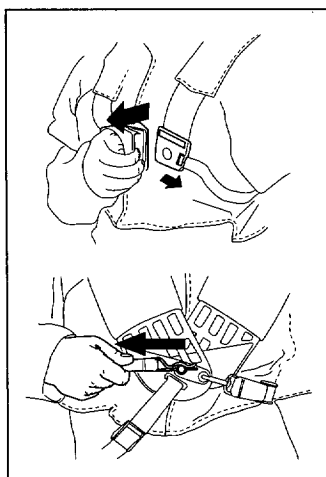

## 6. Silencer

The silencer is designed to give the lowest possible noise level and to direct the engine's exhaust fumes away from the operator.

The engine's exhaust fumes are hot and can contain sparks, which can lead to the outbreak of fire.

In countries that have a warm and dry climate the risk of fire is obvious. We have therefore fitted certain silencers with a spark arrest screen. Make sure that your silencer is fitted with this kind of screen.

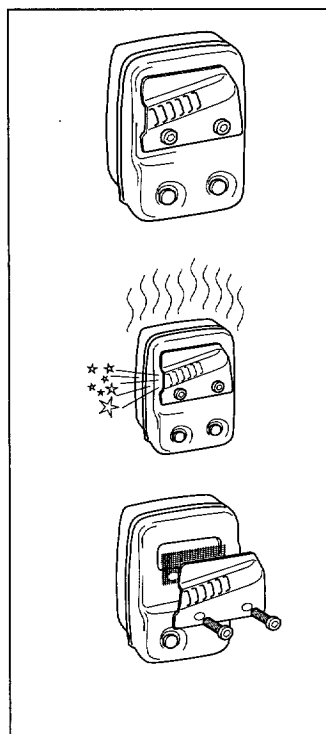

It is extremely important that the instructions for checking, maintaining and servicing the silencer are followed. (see the section "Control, maintenance and service of the machine's safety equipment").



**WARNING!**  
During use and for some time after the silencer is very hot. Do not touch the silencer if it is hot!

## 7. Cutting equipment

1) The saw blade is intended for cutting trees and hard brush.

2) The grass blade is intended for soft brush and heavy grass.

3) The trimmer head is intended for clearing grass.

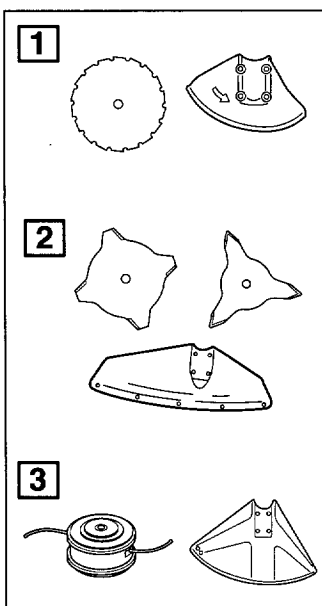

## 8. Locking nut

The locking nut secures the cutting equipment on the output shaft.

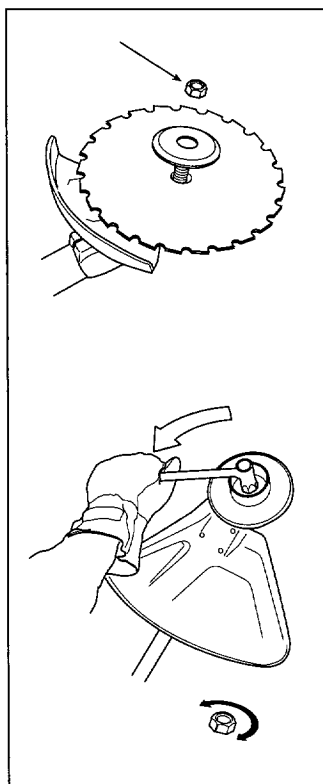

# SAFETY INSTRUCTIONS

## Control, maintenance and service of the machine's safety equipment

### IMPORTANT INFORMATION

- All service and repairs to the machine require special training.
- This applies especially to the machine's safety equipment. If the machine does not meet any of the controls listed below you should contact your service workshop.
- The purchase of one of our products guarantees that professional repair and servicing will be carried out on it. If the point of purchase is not one of our servicing dealers, please ask for details of the closest service workshop.

### 1. Throttle trigger lock

- Check that the throttle is locked in the "idling position" when the throttle trigger lock is in its original position.
- Press in the throttle trigger lock and make sure it returns to its original position when released.

The throttle trigger lock is designed to prevent the throttle from accidentally being engaged. When the trigger lock (A) is pressed into the handle (= when you hold the handle) the throttle (B) is released. When the grip on the handle is released the throttle and the throttle trigger lock return to their original positions. This takes place via two independent return spring systems. This means that the throttle is automatically locked in its "idling" position.

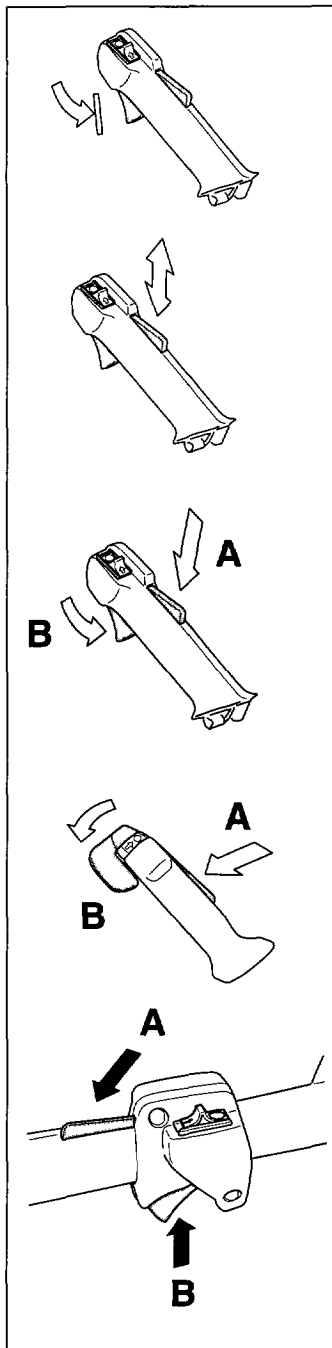

- Start the machine and apply full throttle. Release the throttle and check that the cutting equipment stops and remains at a standstill. If the cutting equipment rotates with the throttle in the idling position then the carburettor's idling setting must be checked. See chapter "Maintenance".

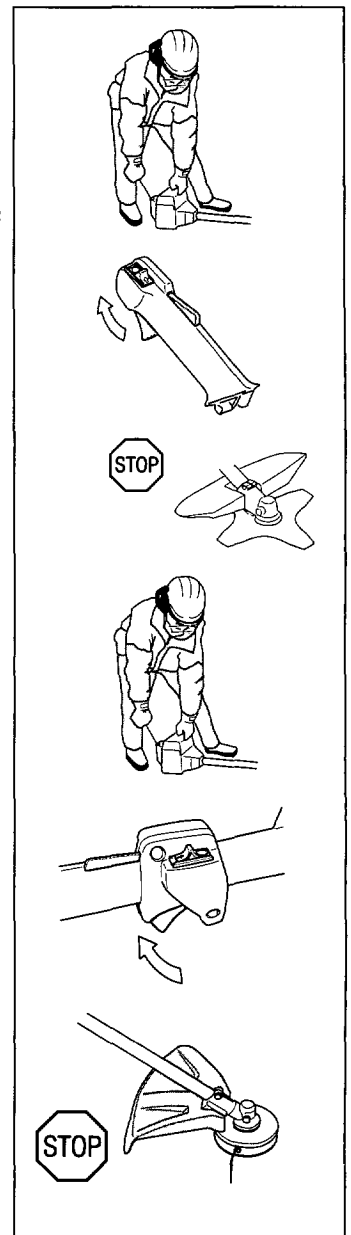

### 2. Stop switch

- Start the engine and make sure that the engine stops when the stop switch is moved to the stop position.

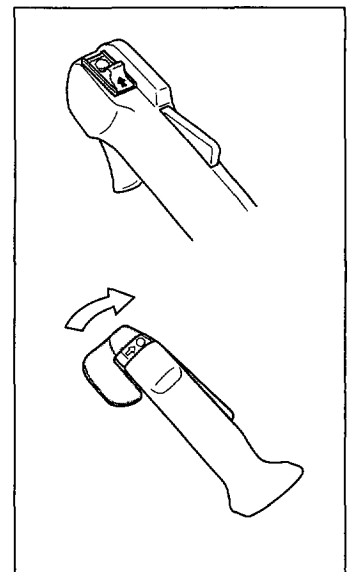

# SAFETY INSTRUCTIONS

## 3. Cutting attachment guard

- Ensure that the blade and spray guard is undamaged and is not cracked.
- Replace the guard if it has been exposed to impact or is cracked.
- Always use the prescribed blade and guard combination, see chapter "Technical data".

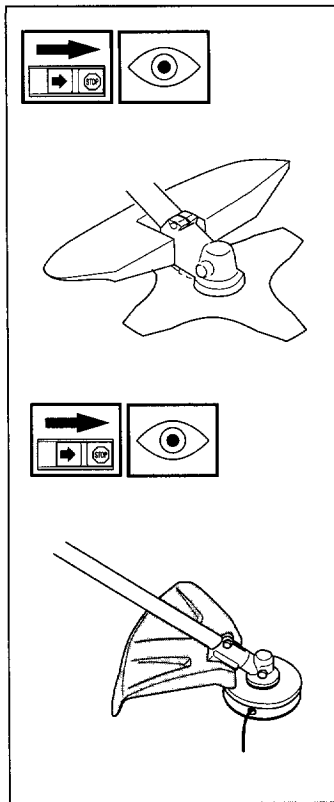

## 4. Vibration damping system

- Check the vibration damping element regularly for material cracks and distortion.
- Check that the vibration damping element is securely attached between the engine unit and the handlebar unit.

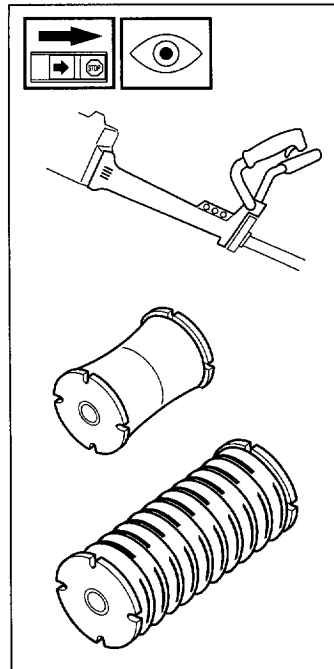

## 5. Silencer

1. Never use a machine that has a defective silencer.
2. Check regularly that the silencer is secure.
3. If your silencer is fitted with a spark arrest screen then it should be cleaned regularly. A blocked screen leads to the engine overheating with serious damage as a result. Never use a silencer with a defective spark arrest screen.

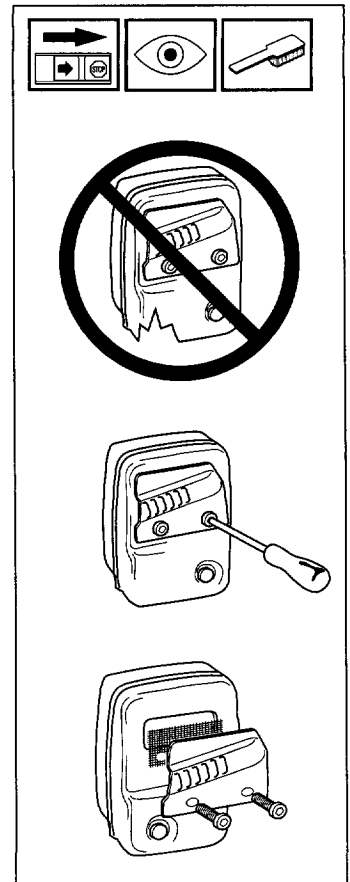



# SAFETY INSTRUCTIONS

## 6. Cutting equipment

This section describes how through correct maintenance and through using the right type of cutting equipment you can:

- Reduce the machine's tendency to kickback
- Obtain maximum cutting capacity.
- Increase the service life of the cutting equipment.

Four basic rules:

- 1) Only use the cutting and guard equipment we recommend! See chapter "Technical data".
- 2) Keep the blade's teeth well and correctly sharpened! Follow our instructions and use the recommended filing gauge. An incorrectly sharpened or damaged blade increases the risk of an accident.
- 3) Keep the correct setting. Follow our instructions and use the recommended setting tool. An incorrectly set blade increases the risk of jamming and kickback.
- 4) Check the cutting equipment with regard to damage and crack formation. Damaged cutting equipment should always be replaced.

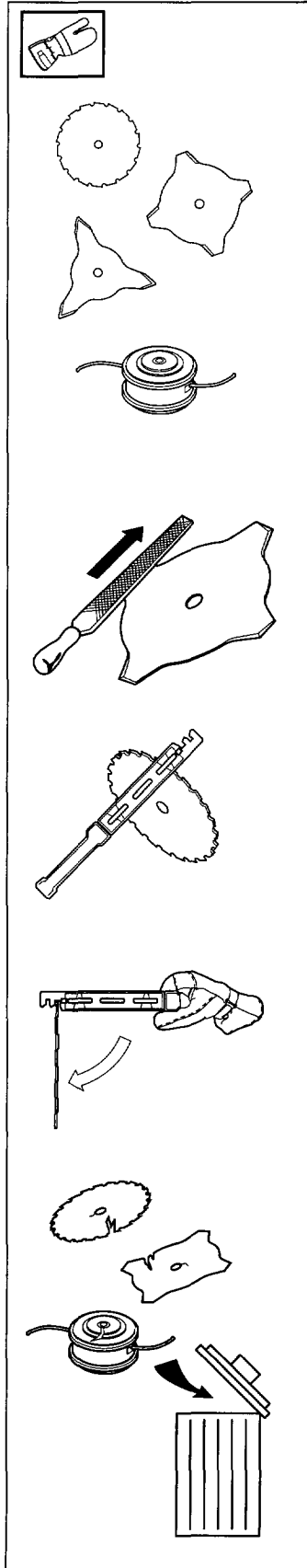

## 7. Quick-release

- Check that the harness straps are correctly positioned. When the harness and machine are adjusted, check the harness' safety release catch to ensure it works correctly.

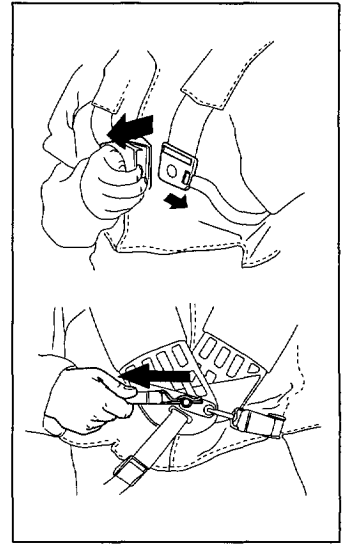

## 8. Locking nut

- Protect your hand from injury when assembling, use the blade guard as protection when tightening with a socket spanner. Tighten the nut by turning against the direction of rotation. Loosen the nut by turning in the direction of rotation. (NOTE! the nut has a left-hand thread).
- Tighten the nut using a socket spanner, 35 - 50 Nm (3.5 - 5 kpm).

### NOTE!

The locking nut's nylon lock must not be so worn that it can be turned by hand. The lock shall hold at least 1.5 Nm. The nut should be replaced after it has been put on approx. 10 times.

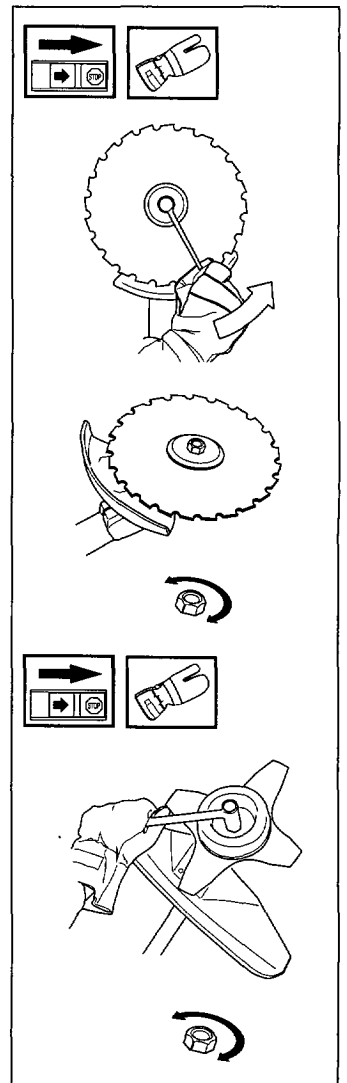

**WARNING!**  
Never use a machine with defective safety equipment. The safety equipment should be maintained as described in this section. If your machine does not meet any of these controls you should contact your service workshop.

# SAFETY INSTRUCTIONS

## Cutting equipment

### IMPORTANT INFORMATION

The section describes how through correct maintenance and through using the right type of cutting equipment you can reduce the machine's tendency to kickback, obtain maximum clearing capacity and increase the service life of the cutting equipment.

- Only use the cutting and guard equipment we recommend! See chapter "Technical data".
- Keep the blade's teeth well and correctly sharpened! Follow our recommendations.
- Maintain the correct setting. Follow our instructions and use the recommended filing gauge.



**WARNING!**  
Incorrect cutting equipment or an incorrectly sharpened blade increases the risk of kickback.

## Sharpening the clearing blade

- A correctly sharpened blade is a prerequisite for working efficiently and to avoid unnecessary wear to the blade and clearing saw.
- Make sure that the blade is well supported when you use the file. Use a 5.5 mm round file with a file holder.
- The sharpening angle is 15°. Every other tooth is sharpened to the right and the intermediate tooth to the left. When the blade has been heavily pitted by stones the upper side of the teeth can, in exceptional cases, need to be dressed using a flat file. In such cases this takes place before sharpening with the round file. Dressing the top side must be carried out equally for all teeth.
- Adjust the setting. This should be 1 mm.

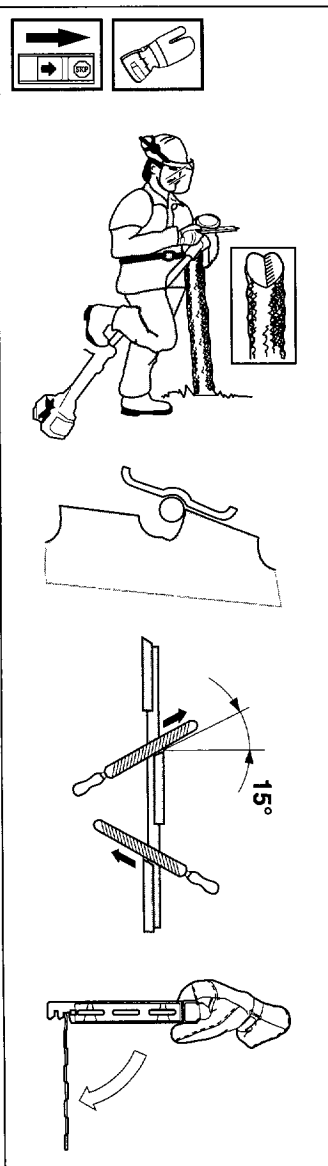

## Sharpening the grass blade

- The blades are reversible and can be turned when one side's edge has become dull.
- The blades are sharpened using a single cut flat file.
- Sharpen all edges equally to maintain the balance of the blade.

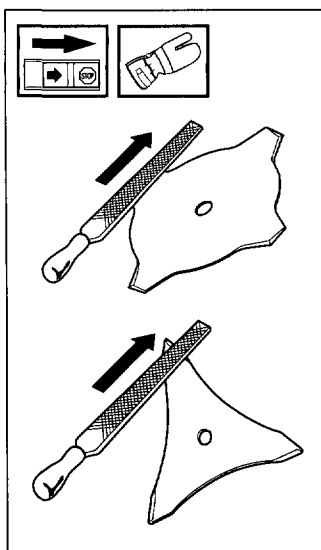

## Trimmer head

- Only use a trimmer head and trimmer cord that is recommended. These have been tested by the manufacturer to suit a particular engine size. This is especially important when a fully automatic trimmer head is used. Only use the cutting equipment we recommend! See chapter "Technical data".
- Generally smaller machines require a small trimmer head and vice versa. This is because when clearing using a cord the engine must throw out the cord radially from the trimmer head and also meet resistance from the grass being cleared.
- The length of the cord is also important. A longer cord requires greater engine power than a shorter cord of the same diameter.
- Make sure the knife positioned on the trimmer guard is intact. This is used to cut the cord to the correct length.
- To increase the life of the cord it can be soaked in water for a few days. This will make the line tougher and it will keep longer.

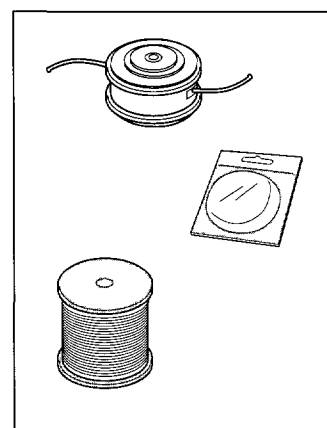

### IMPORTANT INFORMATION

Always ensure the trimmer cord is wound tightly and evenly around the drum, otherwise harmful vibrations will occur.



**WARNING!**  
Always stop the engine before starting work on any part of the cutting equipment. This continues to rotate even after the throttle has been released. Ensure that the cutting equipment has stopped completely and remove the cable from the spark plug before you start to work on it.

# SAFETY INSTRUCTIONS

## General safety instructions

### IMPORTANT INFORMATION

- The machine is only designed for trimming grass, brush cutting and/or forestry clearing.
- The only accessories to be used with the engine unit as a drive source are the cutting units we recommend in the chapter "Technical data".
- Never use the machine if you are tired, if you have consumed alcohol, or if you are taking medicines that can affect your sight, your judgement or the control of your body.
- Use personal protective equipment. See the section "Personal protective equipment".
- Never use a machine that has been modified so that it no longer corresponds with the original design.
- Never use a machine that is faulty. Follow the maintenance, control and service instructions in this Operator's Manual. Some maintenance and service actions should be carried out by trained and qualified specialists. See the chapter "Maintenance".



### WARNING!

Faulty cutting equipment or an incorrectly sharpened blade increases the risk of accidents.

## Start



### WARNING!

When the engine starts with the choke lever in the choke or starter throttle position the cutting tool (blade or trimmer) starts to rotate immediately.

- The complete clutch cover with shaft must be fitted before the machine is started, otherwise the clutch can become loose and cause personal injury.
- Never start the machine indoors. Bear in mind the dangers of inhaling the engine's exhaust fumes.
- Observe your surroundings and make sure that there is no risk of people or animals coming into contact with the cutting equipment.

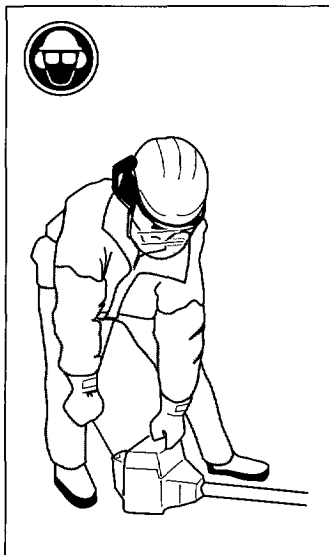

- Place the machine on the ground, make sure the blade is free from branches and stones. Press the machine body against the ground using your left hand and pull the starter cord. (NOTE! Do not use your foot). Grip the starter handle with your right hand and pull the starter cord.

## Fuel safety

- Never fill the machine while the engine is running.
- Provide good ventilation when filling or mixing fuel (petrol and 2-stroke oil).
- Move the machine at least 3 m from the filling position before starting.
- Never start the machine:
  - a) If you have spilt fuel on it. Wipe up all spillage.
  - b) If you have spilt fuel on yourself or your clothes. Change your clothes.
  - c) If there is a fuel leak. Make regular checks for leakage from the fuel cap and the fuel supply pipes.

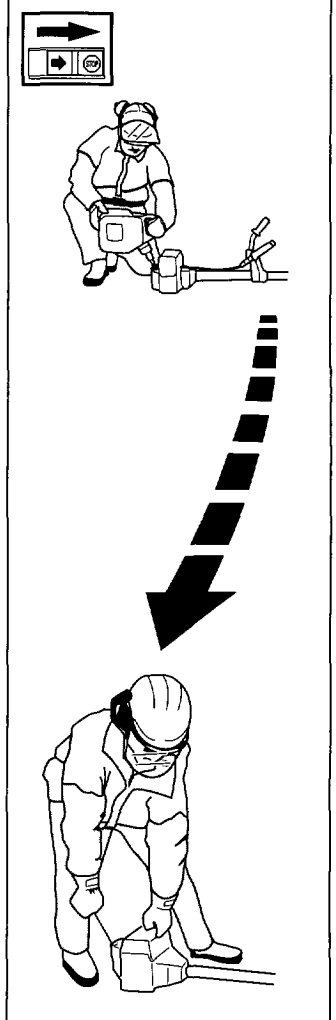

## Transport and storage

- Store and transport the machine and fuel so that any leakage or fumes do not risk coming into contact with sparks or naked flames. For example, electric machines, electric motors, electrical switches/power switches, heaters or the like.
- When storing and transporting fuel approved containers intended for this purpose must be used.
- When storing the machine for long periods the fuel tank must be emptied. Contact your local petrol station to find out how to dispose of excess fuel.
- Always keep the transport guard attached when transporting and storing the machine.



### WARNING!

Exercise great care when handling fuel. Bear in mind the risk of fire, explosions and inhaling fumes.

# SAFETY INSTRUCTIONS

## General working instructions

### IMPORTANT INFORMATION

- This section takes up the basic safety precautions for working with the clearing saw and trimmer.
- If you encounter a situation where you are uncertain how to proceed you should ask an expert. Contact your dealer or your service workshop.
- Avoid all usage which you consider to be beyond your capability.
- Before starting you must understand the difference between forestry clearing, brush cutting and grass trimming.

### Basic safety precautions

1. Observe your surroundings:

- To ensure that people, animals or other things cannot affect your control of the machine.
- To ensure that the above mentioned do not come into contact with the cutting equipment or objects that can be thrown by the cutting equipment.
- NOTE! Never use a machine without the possibility of calling for help in the event of an accident.

2. Avoid usage in unfavourable weather conditions. For example, thick fog, heavy rain, strong winds or extreme cold, etc. To work in bad weather conditions is tiring and can create dangerous circumstances, e.g. slippery surfaces, affect a tree's direction of fall, etc.

3. Make sure you can walk and stand safely. Look out for any obstacles with unexpected movement (roots, stones, branches, pits, ditches, etc.). Take great care when working on sloping ground.



4. Take great care when cutting a tree that is subject to tension. A tree that is under tension can spring back to its original position both before and after being cut. Incorrect positioning on your behalf or when positioning the cut can result in the tree hitting you or the machine so that you lose control. Both situations can cause serious personal injury.

5. The engine should be switched off before moving. When moving over longer distances and transporting the transport guard should be used.

6. Never put the machine down with the engine running unless you have good sight of it.



# SAFETY INSTRUCTIONS

## Adjusting the harness and clearing saw



**WARNING!**  
When working with the clearing saw it should always be hooked in the harness. If this is not done, you cannot control the clearing saw safely and this can result in injury to yourself or someone else.

On the front is an easily accessible, quick release catch. Use this if the engine should catch fire or in any other emergency situation where you quickly need to free yourself from the harness and machine.

### Even load on the shoulders

A well-adjusted harness and clearing saw significantly facilitates working. Adjust the harness for the best working position. Tension the side straps so that the weight is evenly distributed across the shoulders.

### Correct height

1) Forestry clearing  
Adjust the carrier strap so that the suspension hook comes approximately 10 cm under the hip. The blade should be angled forward a little.

2) Grass clearing  
The suspension hook should hang approximately 20 cm under the hip so that the blade is parallel to the ground.

### Correct balance

1) Forestry clearing  
Move the suspension eye forwards or backwards. If the blade is balanced a 10-20 cm above the ground it is easier to avoid stones.

2) Grass and brush cutting.  
Let the blade balance at a comfortable clearing height, i.e. close to the ground.



## Basic clearing techniques

- Always carry out clearing and trimming at full throttle.
- Always drop to idling speed after each working operation. Longer periods running at full throttle without loading the engine (that is without resistance, which the engine feels from the cutting equipment when trimming) can lead to serious engine damage.

## Designations

- Forestry clearing is a general term for cutting small trees where each stem is cut individually. A saw blade is used.
- Brush cutting is a general term for clearing small, soft bushes. Often several in the same movement. A grass blade can be used.
- Grass clearing is a general term for clearing (trimming) grass. Sweeping movements are made with the cutting tool. A grass blade or trimmer head can be used.

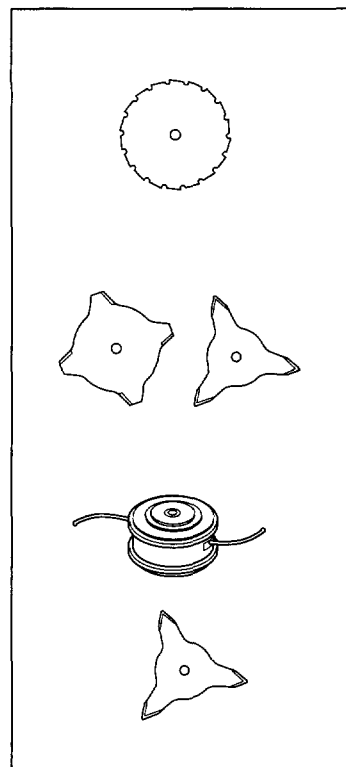

**WARNING!**  
Sometimes grass can collect in the spray guard and cutting head. Always stop the engine when cleaning.

# SAFETY INSTRUCTIONS

## Clearing's ABC

- A. Always use the correct equipment.
- B. Always have well adjusted equipment.
- C. Follow the safety instructions.
- D. Organise the work well.
- E. Always use full throttle when applying the blade.
- F. Always use a sharp blade.
- G. Avoid stones.
- H. Guide the direction of fall (use the wind).



**WARNING!**  
**Avoid cutting in the cutting region between 12 and 3 o'clock on the blade. Kickback can occur due to the blade's rotation speed in this area of the blade when applied on thick stems.**

## Working methods

- Before you start clearing, check the clearing area, its condition, slopes, if there are stones, pits, etc.
- Thereafter start at the end which is easiest, and make a good start to the clearing.

- Work systematically to and fro and across the area. Each stroke should encompass a working area of 4-5 metres. This then utilises the full working area of the machine in both directions and provides the operator with an easy and variable working area to work through.

- The length of the pathway should be approx. 75 m. Move the fuelling station as work progresses.

- On sloping ground the pathway should run parallel to the slope. It is far easier to work along a slope then up and down a slope.

- The pathway should be planned so that you avoid going over ditches or other obstacles. Also adapt the pathway to the wind conditions so that the cleared stems fall on the part of the stand that has been cleared.

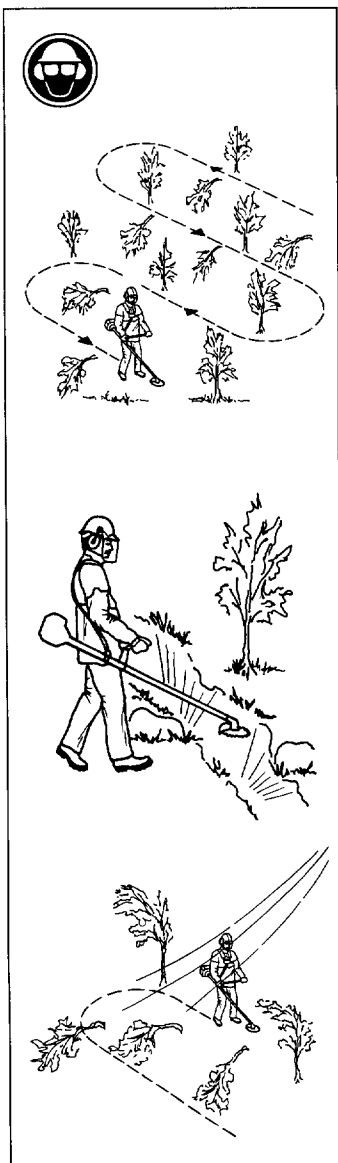

## Forestry clearing using a saw blade

- When applying the blade to heavier stems the risk of kickback increases. You should therefore avoid applying the blade on the cutting area between 12 and 3 o'clock.

- To fell to the left, the lower section of the tree should carry to the right. Angle the blade and move it with a resolute movement diagonally down to the right. At the same time press against the stem using the blade guard. Apply the blade on the area between 3-5 o'clock. Use full throttle when applying the blade.

- To fell to the right, the lower section of the tree should carry to the left. Angle the blade and move it with a resolute movement diagonally up to the left. Apply the blade on the area between 7 and 9 o'clock so that the blade's direction of rotation carries the lower section of the tree to the left.

- To fell a tree forwards the lower section of the tree should be drawn backwards. Draw the blade backwards with a quick and resolute movement.

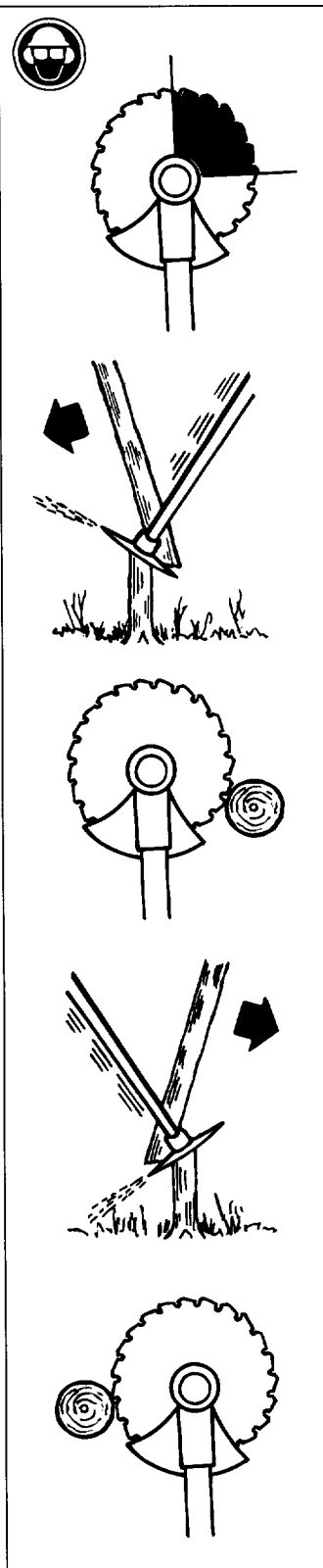

# SAFETY INSTRUCTIONS

- Large stems must be cut from two sides. Determine in which direction the stem should fall. First apply the saw to the felling side. Then cut from the other side to fell the stem. The feed pressure should be applied with regard to the size of the stem's hardness. Small stems require more pressure, while large stems require less pressure.
- If the stems are tightly packed adapt the through-speed with this in mind.

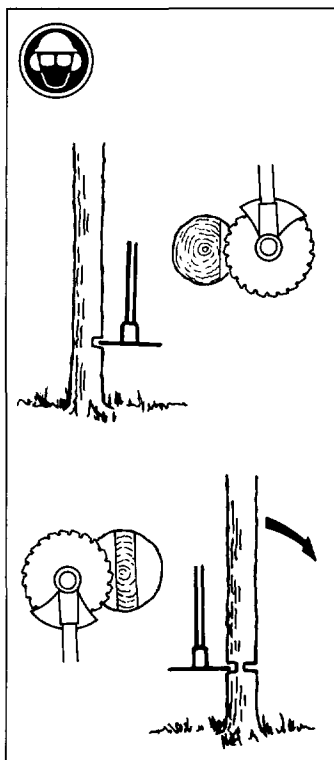

- If the blade should jam in the stem, never jerk the machine free. If you do this the blade, angle gear, shaft or the handlebars can be damaged. Release the handlebars and grip the shaft with both hands and slowly pull the machine free.

## Brush cutting using the saw blade

- Thin stems and brush are mown down. Work by swinging the machine sideways.
- Try to cut several stems in one movement.
- With groups of hardwood stems, first clear around the group. Cut high on the stems around the outside of the group. Then try to come in with the blade so that you can cut from the centre of the group. If it is still difficult to gain access, cut long stumps and let the stems fall down. This then reduces the risk of jamming.

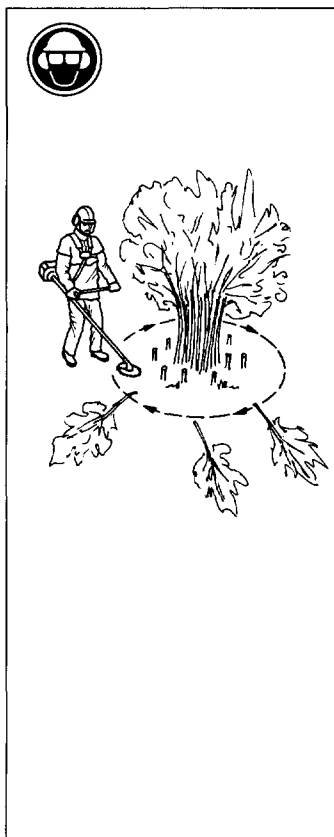

## Grass clearing and soft brush cutting using a grass blade

- Use the blade for all types of high and thick grass as well as for brush cutting. The blade can cut brush up to about the thickness of a finger.
- If the blade is angled a little to the left when cutting grass, the grass will collect in a line, which facilitates collection, e.g. when raking.
- Brush is cut down with a sideways, swinging movement where the movement from right to left is the clearing swing while the movement from left to right is the return swing. Let the blade work on the left-hand side (between 8 and 12 o'clock).
- Try to work rhythmically. Stand firmly with your feet apart. Move forward after the return movement and stand firmly again.
- Let the support cup rest gently against the ground. It is used to protect the blade from digging into the ground.
- Reduce the risk of material wrapping around the blade by following these instructions:
  - a) Always work at full throttle.
  - b) Avoid the previously cut material during the return movement.
- Stop the engine and blade and then release the shoulder strap from the tool before you start to collect the cut material.

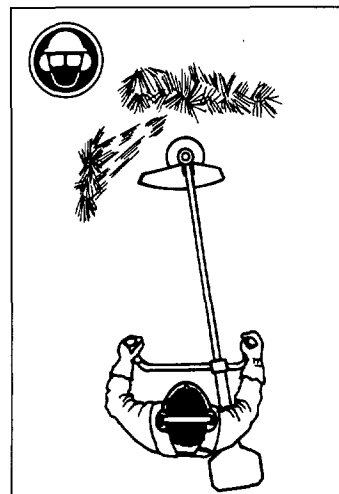

### WARNING!

Neither the user of the tool or anyone else may attempt to remove the cut material while the engine is running or with the blade rotating as this can result in serious injury.

Stop the engine and blade before you remove material that has wound around the blade as otherwise there is a risk of injury.



### WARNING!

Beware of thrown objects. Always wear eye protection. Never lean over the blade or spray guards. Stones rubbish etc. can be thrown up into the eyes resulting in blindness or other serious injury. Keep unauthorised persons at a distance. Children, animals, onlookers and helpers should be outside the safety zone of 15 meters (50 feet). Stop the machine immediately if anyone approaches.

# SAFETY INSTRUCTIONS

## Grass clearing using the trimmer head

- Hold the trimmer head just above the ground at an angle. It is the end of the cord that carries out the work. Let the cord work at its own pace. Do not press the cord into the area to be cut.
- The cord can easily remove grass and weeds up against walls, fences, trees and borders, however, it can also damage sensitive bark on trees and bushes and damage fence posts.
- Reduce the risk of damaging plants by shortening the cord to 10-12 cm and reducing the engine speed.

## Clearing

- The clearing technique removes all unwanted vegetation. Keep the trimmer head just above the ground and tilt it. Let the end of the cord strike the ground around trees, posts, statues and the like. **NOTE!** This technique increases the wear on the cord.
- The cord wears quicker and must be fed forward more often when working against stones, brick, concrete, metal fences, etc. than when coming into contact with trees and wooden fences.
- When trimming and clearing you should use less than full throttle so that the cord lasts longer and to reduce the wear on the trimmer head.

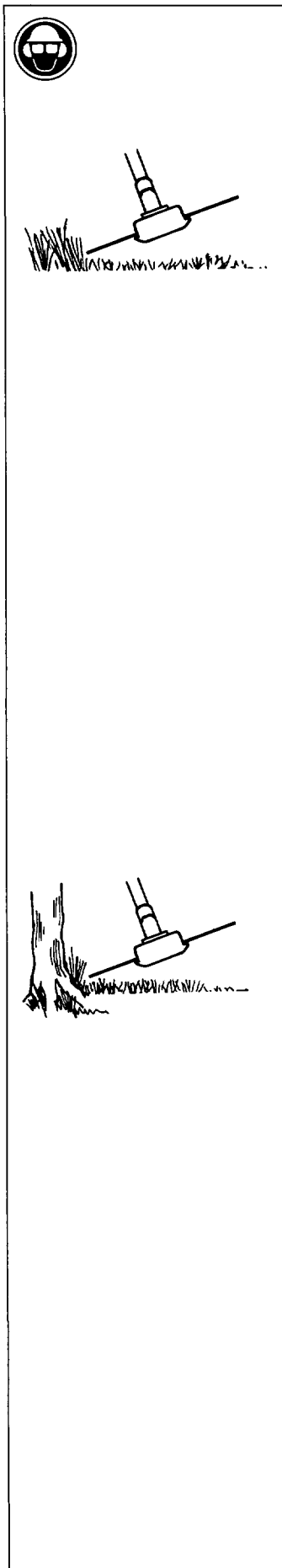

## Trimming

- The trimmer is ideal to cut grass that is difficult to reach using a normal lawn mower. Keep the cord parallel to the ground when cutting. Avoid pressing the trimmer head against the ground as this can ruin the lawn and damage the tool.
- Do not allow the trimmer head to constantly come into contact with the ground during normal cutting procedures. Constant contact can cause damage and wear to the trimmer head.

## Sweeping

- The rotating cord's fanning effect can be used for quick and easy cleaning. Hold the cord parallel to and above the area to be swept and move the trimmer from side to side.
- When cutting and sweeping you should use full throttle to obtain the best results.

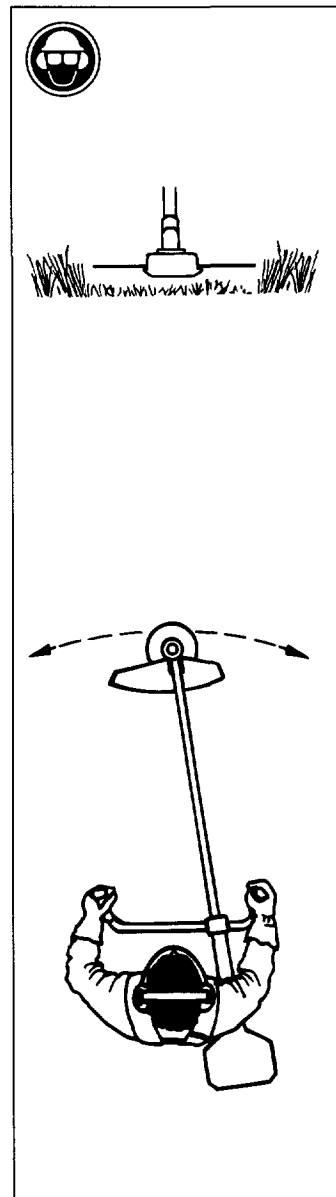

## WARNING!

**Beware of thrown objects. Always wear eye protection. Never lean over the blade or spray guards. Stones rubbish etc. can be thrown up into the eyes resulting in blindness or other serious injury. Keep unauthorised persons at a distance. Children, animals, onlookers and helpers should be outside the safety zone of 15 meters (50 feet). Stop the machine immediately if anyone approaches.**



# WHAT IS WHAT?

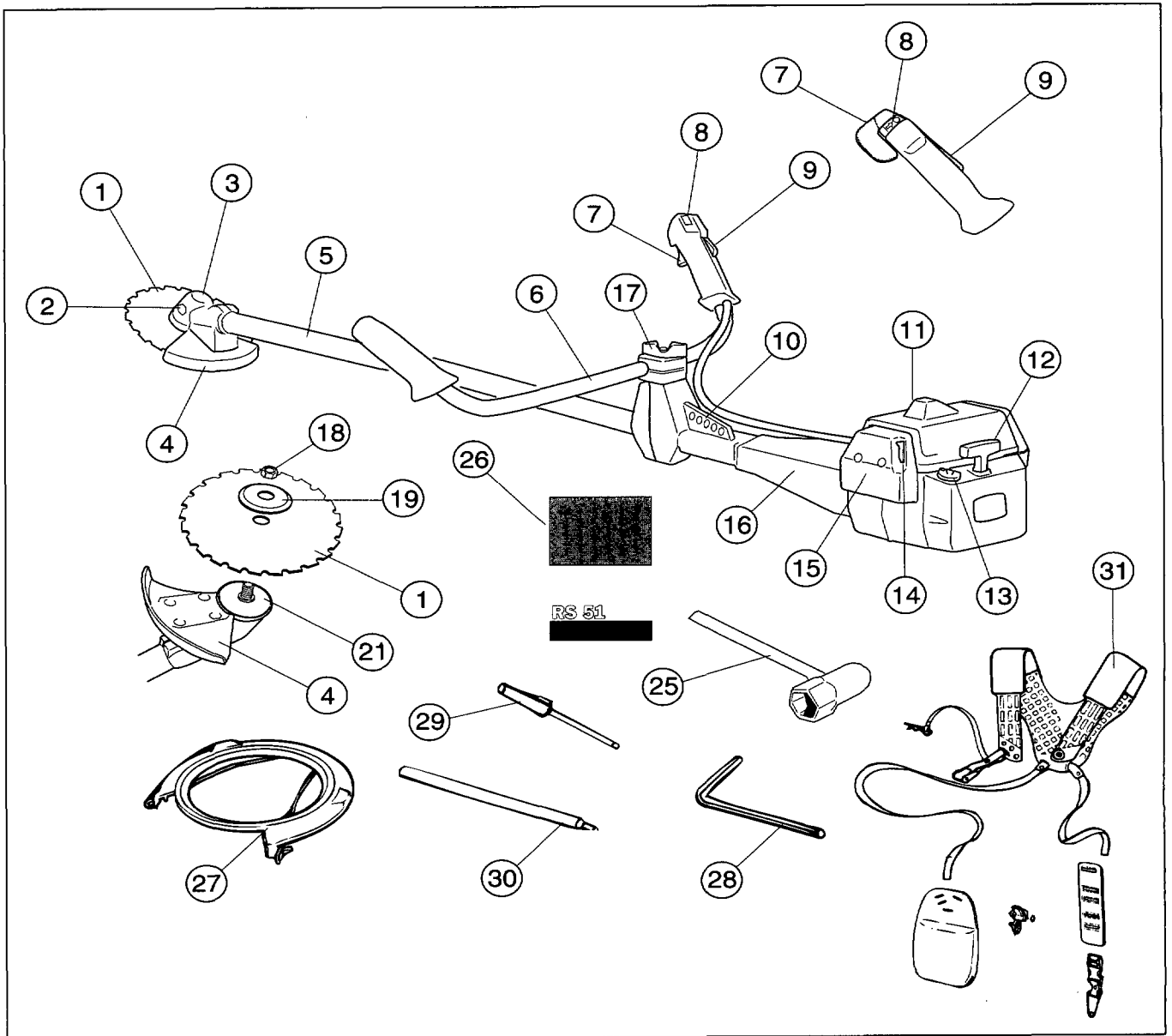

## What is what on the clearing saw?

- |     |                             |     |                         |
|-----|-----------------------------|-----|-------------------------|
| 1.  | Blade                       | 15. | Air filter cover        |
| 2.  | Grease filler cap           | 16. | Clutch cover            |
| 3.  | Angle gear                  | 17. | Handlebar adjustment    |
| 4.  | Blade guard                 | 18. | Locking nut             |
| 5.  | Shaft                       | 19. | Support flange          |
| 6.  | Handlebars                  | 21. | Drive disc              |
| 7.  | Throttle                    | 25. | Socket spanner          |
| 8.  | Stop switch                 | 26. | Operator's Manual       |
| 9.  | Throttle trigger lock       | 27. | Transport guard         |
| 10. | Suspension for clearing saw | 28. | Allen key               |
| 11. | Cylinder cover              | 29. | Carburettor screwdriver |
| 12. | Starter handle              | 30. | Locking pin             |
| 13. | Fuel tank                   | 31. | Harness                 |
| 14. | Choke                       |     |                         |

# ASSEMBLY

## Assembling the handlebars

- Remove the screw at the rear of the throttle handle.
- Slide on the throttle handle on the right-hand side of the handlebars, (see the diagram).
- Align the hole in the throttle handle for the fixing screw with the hole on the handlebars.
- Refit the screw in the rear of the throttle handle.
- Fit the screw through the throttle handle and the handlebars and tighten.
- Unscrew the handle and plastic cover from the handlebar bracket.
- Place the handlebars with the handlebar holder on the handlebar bracket. Fit the handle and plastic cover. Do not tighten too tight.
- Put on the harness and hang the machine in the suspension hook. Now finely adjust so that the machine gives a comfortable working position when it's attached to the harness. Tighten the handle.

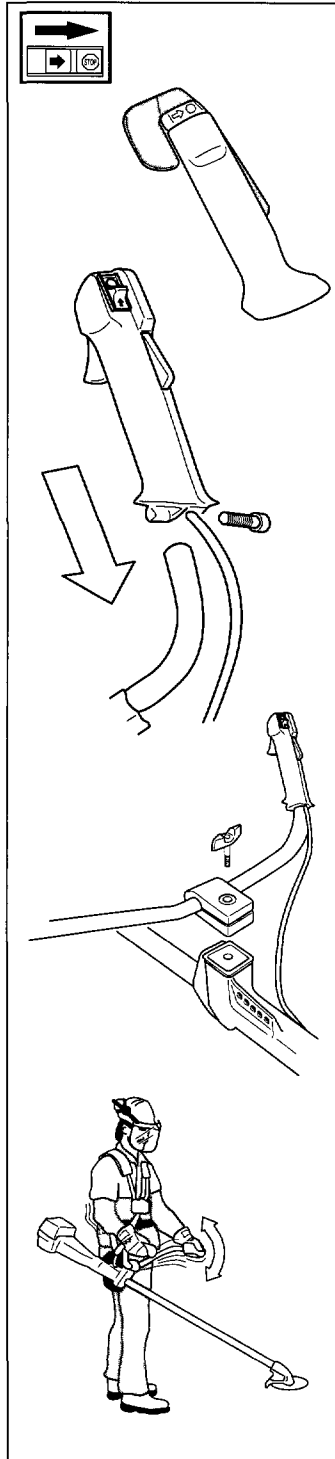

## Transport position, handlebars

- The handlebars can easily be turned to fit along the shaft for easy transportation and storage.
- Loosen the knob. Turn the handles clockwise so that the throttle comes against the engine.
- Thereafter fold the handlebars around the shaft. Tighten the handle.
- Attach the transport guard.

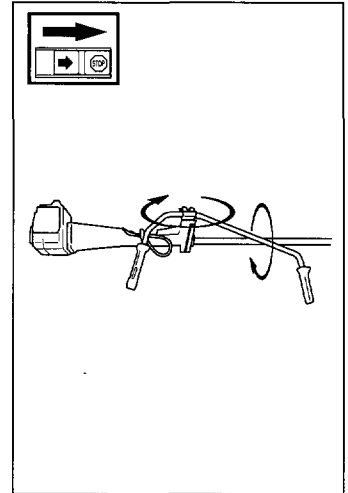

# ASSEMBLY

## Assembly of the blade guard and blade



**WARNING!**  
Under no circumstances may the blade be used without the recommended blade guard fitted. Serious injury can be caused if the wrong or a defective blade guard is fitted. See the chapter "Technical data". A blade must not be assembled on machines with loop handlebars!

- The guard (A) is fitted using 4 screws (L) and the support plate (M) as set out in the diagram. NOTE! Use the recommended blade guard.
- Fit the drive disc (B) on the output axle.
- Turn the blade axle until one of the holes in the drive disc aligns with the hole in the gear housing.
- Insert the locking pin (C) in the hole so that the axle is locked.
- Place the blade (D), support cup (E) and support flange (F) on the output axle.
- Fit the nut (G). The tightening torque of the nut is 35-50 Nm (3.5 - 5 kpm). Use the socket spanner in the tool kit. Hold the handle of the spanner as close to the blade guard as possible. The nut is tightened when the spanner is turned against the direction of rotation (left-hand thread).

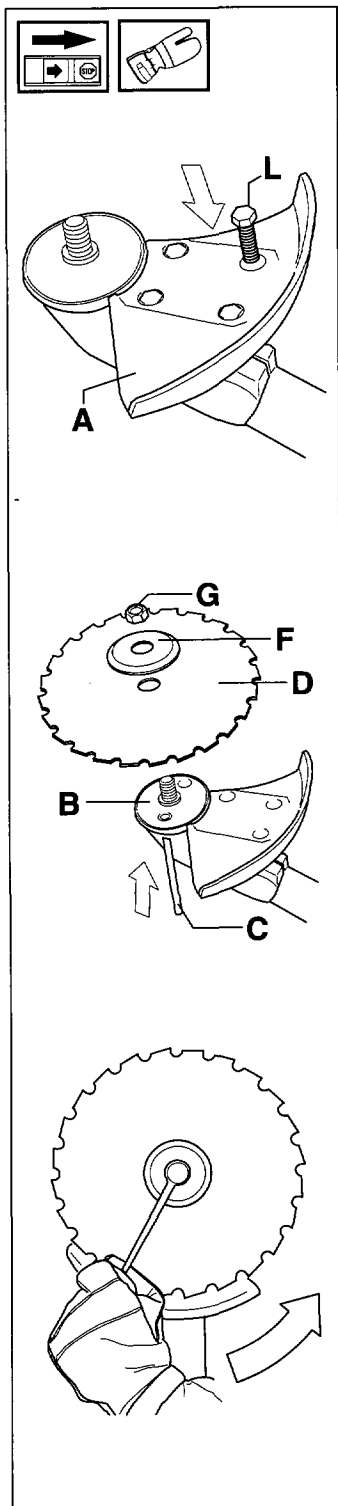

## Assembly of the trimmer head (Autohead)

- Fit the guard (A) intended for use with the trimmer head. Secure using the 4 bolts (L) and the support plate (M) as set out in the diagram.
- Fit the drive disc (B) on the output axle.
- Turn the blade axle until one of the holes in the drive disc aligns with the hole in the gear housing.
- Insert the locking pin (C) in the hole so that the axle is locked.
- The trimmer head must be split to be fitted (see the diagram). Proceed as follows:
  - Insert your finger into the centre hole of the cover (I) at the same time as you hold the cover with your other fingers. Press the two catches (J) that extend from the cut-out on the bottom section (K) using the thumb and index finger of your other hand. Press apart the trimmer head using the fingers on the cover.
- Place the cover (I) and the support flange (F) on the output axle.
- Fit the nut (G). The tightening torque of the nut is 35-50 Nm (3,5 - 5 kpm). Use the socket spanner in the tool kit. Hold the handle of the spanner as close to the blade guard as possible. The nut is tightened when the spanner is turned against the direction of rotation (left-hand thread).

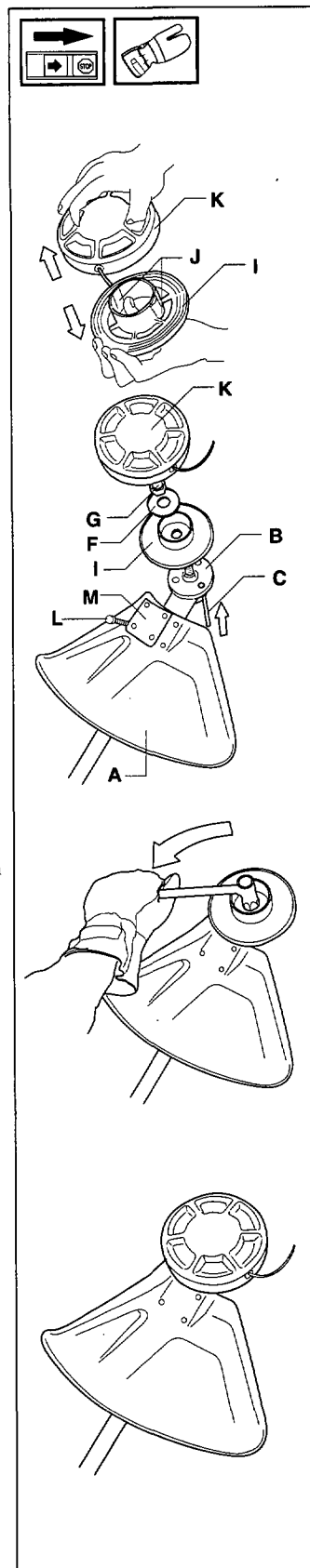

- Fit the trimmer head's bottom section (K) on the cover (I) by pressing the two sections together with the cut-outs on the bottom section aligned with the catches on the cover.
- To dismantle follow the instructions in the reverse order.

# ASSEMBLY

## Assembly of the trimmer head (Polytrim head)

Fit the guard intended for use with the trimmer and Polytrim heads. Secure using 4 bolts and the support plate as set out in the diagram.

- Fit the drive disc on the output axle.
- Turn the blade axle until one of the holes in the drive disc aligns with the hole in the gear housing.
- Insert the locking pin in the hole so that the axle is locked.
- Screw on the trimmer head/Polytrim head, turn against the direction of rotation.
- To dismantle follow the instructions in the reverse order.

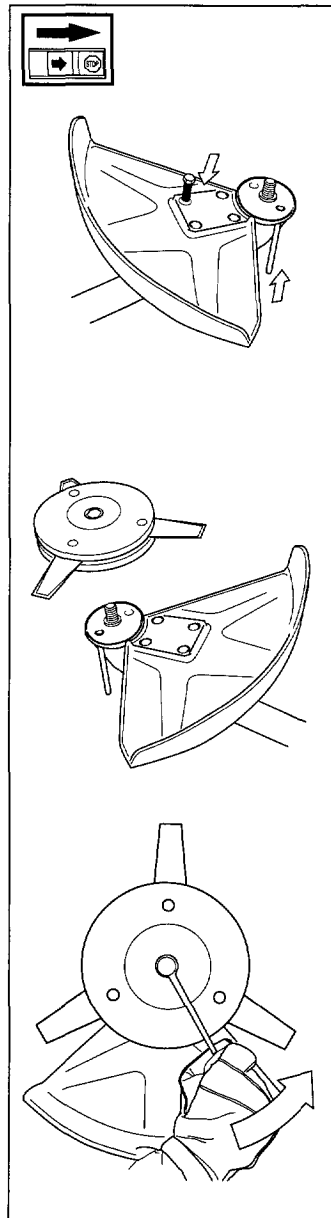

## Assembly of the trimmer head (Trimmy SII)

- Fit the correct guard (A) for working with a trimmer head. Secure using 4 bolts (L) and the support plate (M) as shown.

- Fit the driver plate (B) on the drive shaft.
- Rotate the drive shaft so that one of the holes in the driver plate lines up with the corresponding hole in the gear housing.
- Insert the locking pin (C) into the hole to lock the shaft.
- Screw on the trimmer head (H) in the opposite direction to the normal direction of rotation.
- Tighten the trimmer head to a torque of 20 Nm (2 kpm).
- To remove the trimmer head just reverse the sequence.

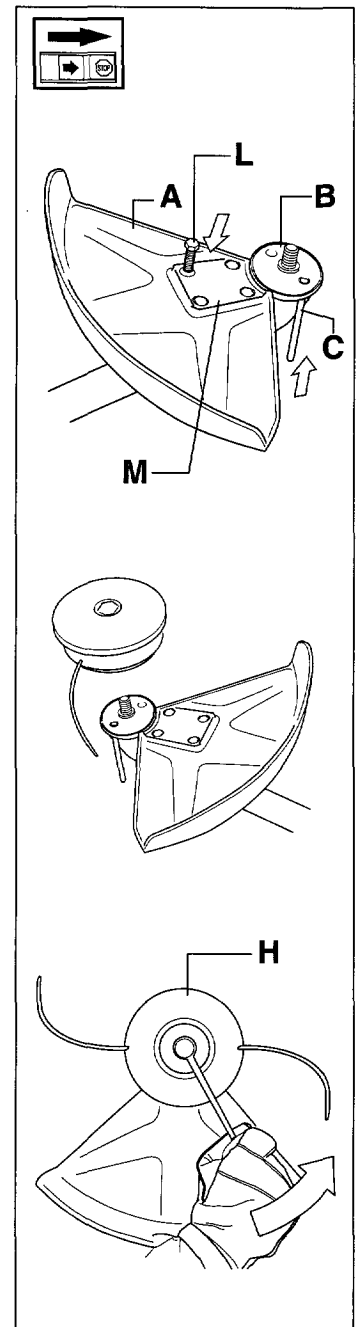

## Assembly of the blade and trimmer head

It is extremely important, when fitting the cutting equipment that the drive dic's guide aligns correctly with the cutting equipment's centre hole. Incorrectly fitted cutting equipment can cause serious and/or fatal personal injury.

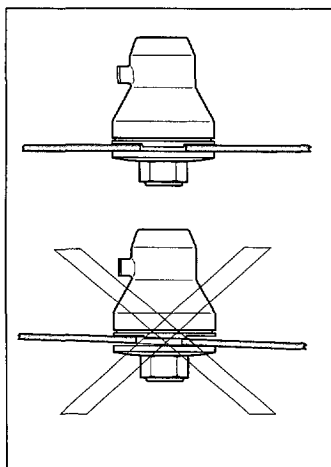

## Adjusting the harness and clearing saw



**WARNING!**  
When working with the clearing saw it should always be hooked in the harness. If this is not done, you cannot control the clearing saw safely and this can result in injury to yourself or someone else. Never use a harness with a defective quick release catch.

### Quick release

On the front is an easily accessible, quick release catch. This is activated by pulling the outer part of the chest plate straight out. Use this if the engine should catch fire or in any other emergency situation when you quickly need to take off the harness and machine.

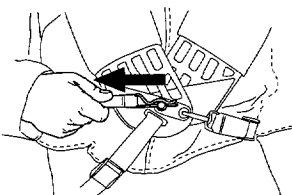
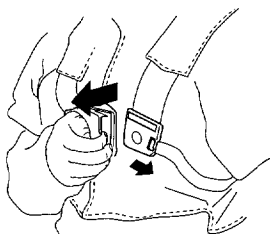

### Even load on the shoulders

A well-adjusted harness and clearing saw significantly facilitates working. Adjust the harness for the best working position. Tension the side straps so that the weight is evenly distributed across the shoulders.



### Correct height

The suspension hook should hang approximately 20 cm under the hip so that the blade/trimmer head is parallel to the ground.



### Correct balance

Let the blade/trimmer head balance close to the ground.



# FUEL HANDLING

## Fuel mixture

### NOTE!

Clearing saws are fitted with two-stroke engines and must always be run on a mixture of petrol and two-stroke oil. To ensure the correct mixture proportions it is important to measure the quantity of oil accurately. When mixing small amounts of fuel small discrepancies in the amount of oil has a great bearing on the proportions of the fuel mixture.



**WARNING!**  
Always provide good ventilation when handling fuel.

## Petrol

- Use unleaded or quality leaded petrol.
- The lowest recommended octane rating is 90. If you run the engine on a petrol with a lower octane rating than 90 so-called "knocking" can occur. This leads to an increased engine temperature, which can result in a serious engine breakdown.
- When working at continuous high revs a higher octane rating is recommended.

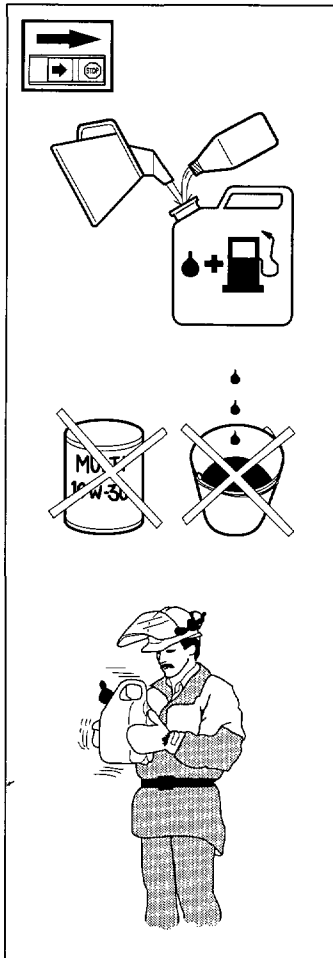

## Two-stroke oil

- For the best results use JONSERED two-stroke oil, which has been specially produced for clearing saws. Mixing ratio 1:50 (2%).
- If JONSERED two-stroke oil is not available you can use a high quality two-stroke oil intended for air cooled engines. Contact your dealer when selecting an oil. Mixing ratio: 1:33 (3%).
- Never use two-stroke oil intended for water cooled outboard motors, so-called outboard motor oil.
- Never use oil intended of four-stroke engines.

## Mixture

- Always mix petrol and oil in a clean container intended for petrol.
- Always start by filling half the quantity of petrol required. Then add the entire oil quantity. Mix (shake) the fuel mixture. Fill the remaining quantity of petrol.
- Mix (shake) the fuel mixture carefully before filling in the machine's fuel tank.
- Do not mix more than max. one month's supply of fuel.
- If the clearing saw is not used for a long period of time, the fuel tank should be emptied and cleaned.

## Fuelling



**WARNING!**  
The following precautions reduce the risk of fire:  
Do not smoke or place any sources of heat in the vicinity of the fuel. Never refuel when the engine is running. Always stop the engine and let it cool for a few minutes before refuelling. Open the fuel cap slowly when fuelling so that any over pressure is released slowly. Tighten the fuel cap carefully after refuelling. Always move the machine from the fuelling place before starting.

- Clean around the fuel cap. Contamination in the tank can disrupt operations.
- Ensure that the fuel is well mixed by shaking the container before filling the tank.

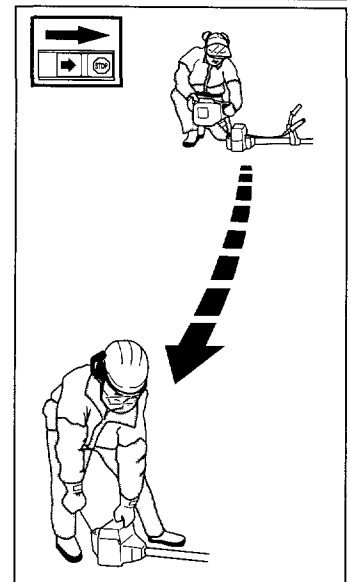

Gasolin Benzin Essence Gasolina Lit.	Oil • Öl Huile • Aceite Lit.	
	2% (1:50)	3% (1:33)
5	0,10	0,15
10	0,20	0,30
15	0,30	0,45
20	0,40	0,60
US gallon	US fl. oz.	
	2% (1:50)	3% (1:33)
1	2 1/2	3 3/4
2 1/2	6 1/2	9 3/4
5	12 7/8	19 1/4

# START AND STOP

## Control before starting

For reasons of safety follow these recommendations!

- Check the blade to ensure that no cracks have formed at the bottom of the teeth or by the centre hole. The most common reason why cracks are formed is that sharp corners have been formed at the bottom of the teeth while sharpening or that the blade has been used with dull teeth. Discard a blade if cracks are found.
- Check that the support flange is not cracked due to fatigue or due to being tightened too much. Discard the support flange if it is cracked.
- Ensure that the blade nut has not lost its tightening capacity. The nut lock shall have a locking torque of at least 1.5Nm. The nut's tightening torque shall be 35-50 Nm.
- Check that the blade guard is not damaged or cracked. Replace the guard if it has been exposed to impact or if it is cracked.
- Check that the trimmer head and the trimmer guard are not damaged or cracked. Replace the trimmer head or trimmer guard if it has been exposed to impact or if it is cracked.
- Never use a machine without a blade guard or with a defective blade guard.

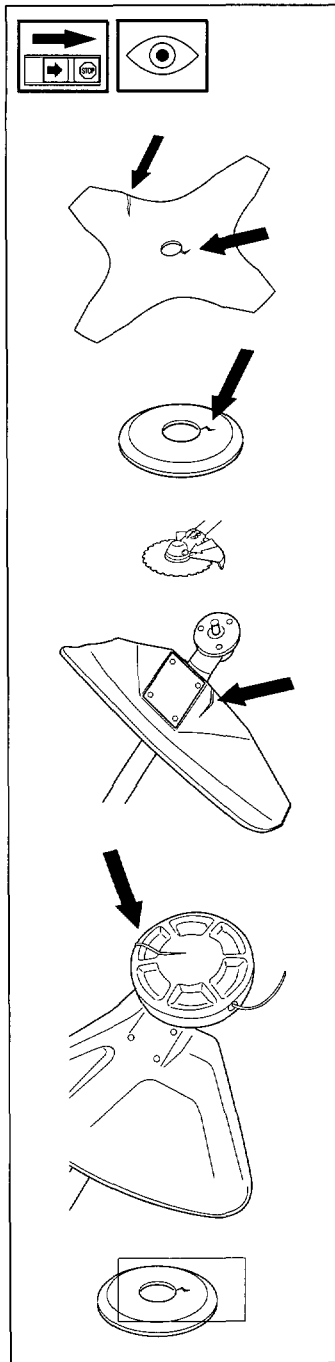

## Start and stop



### WARNING!

**The complete clutch cover with shaft must be fitted before the machine is started, otherwise the clutch can become loose and cause personal injury.**

**Always move the machine from the filling position before starting. Place the machine on a flat surface. Bear in mind the tool rotates when the engine is started. Make sure the blade/trimmer head cannot come into contact with any object. Make sure that no unauthorised persons are in the working area, otherwise there is a risk of serious personal injury. The safety distance is 15 metres.**

## Cold engine

**IGNITION:** Set the stop switch to the start position.  
**CHOKE:** Set the choke control in the choke position.

## Warm engine

Use the same starting procedure as for the cold engine, but do not set the choke control in the choke position. The start throttle position is obtained by setting the choke control in the choke position and then returning it to its original position.

## Stop

The engine is stopped by switching off the ignition.

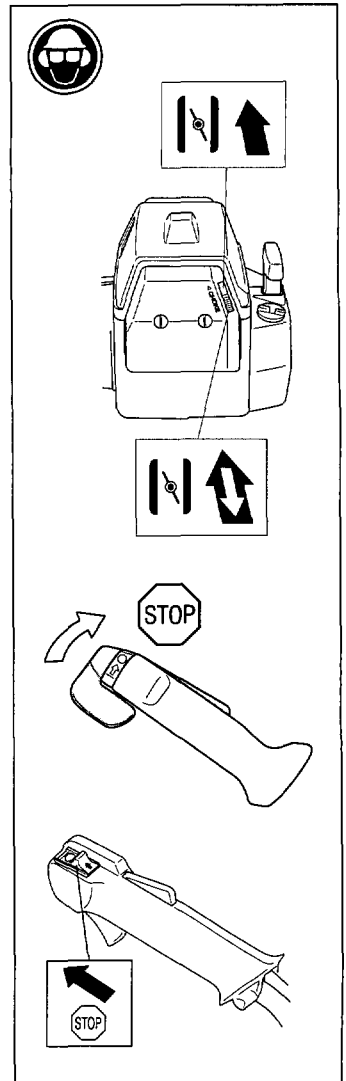

## Start



### WARNING!

**When the engine starts with the choke lever in the choke or starter throttle position the cutting tool (blade or trimmer) starts to rotate immediately.**

Press the machine body against the ground using your left hand (NOTE! Do not use your foot). Grip the starter handle with your right hand and slowly pull the starter cord out until you feel some resistance, (the starter hooks grip) now quickly and powerfully pull the cord.

Immediately press the choke control in when the engine fires and repeat until the engine starts. When the engine starts, quickly apply full throttle and the start throttle will automatically disengage.

**NOTE!** Do not pull the starter cord out completely and do not release the starter cord from the fully extended position. This can damage the machine.

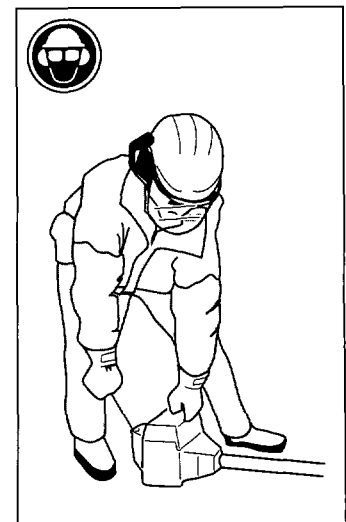

# MAINTENANCE

## Carburettor



### WARNING!

The complete clutch cover with shaft must be fitted before the machine is started, otherwise the clutch can become loose and cause personal injury.

## Operation

- The carburettor governs the engine's speed via the throttle. Air/fuel is mixed in the carburettor. The air/fuel mixture is adjustable. To take advantage of the engine's optimal output the adjustment must be correct.

- The setting of the carburettor means that the engine is adapted to local conditions, for example, the climate, altitude, petrol and the type of 2-stroke oil.

- The carburettor is equipped with three adjustment possibilities:

L = Low speed needle

H = High speed needle

T = Idle speed adjuster screw

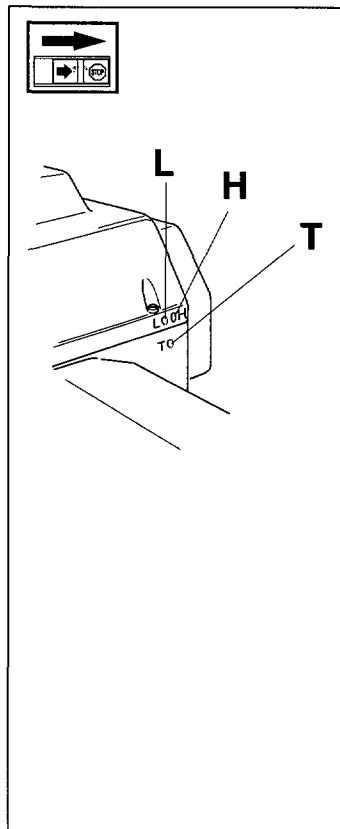

- The fuel quantity in relation to the air flow permitted by the throttle opening is adjusted using the L and H-needles. Turning the needles clockwise gives a leaner fuel mixture (less fuel) and turning them anti-clockwise gives a richer fuel mixture (more fuel). A leaner mixture gives high revs while a richer mixture give less revs.

- The T-screw regulates the position of the throttle while the engine is idling. Turning the screw clockwise gives a higher idling speed while turning it anti-clockwise gives a lower idling speed.

## Basic setting

- The carburettor is set to its basic setting when test run at the factory. The basic setting is richer than the optimal setting and should be kept during the machine's first working hours. Thereafter the carburettor should be finely adjusted. Fine adjustment should be carried out by a skilled technician. The basic setting can vary between: H = 1 to 1 1/4 turns resp. L = 1 to 1 1/4 turns.

**NOTE!** If the blade rotates while the engine is idling the T-screw should be turned anti-clockwise until the blade stops. Rec. idling speed 2 700 rpm.



### WARNING!

If the idling speed cannot be adjusted so that the blade stops, contact your service workshop. Do not use the machine until it has been correctly adjusted or repaired.

### NOTE!

The machine should only be used for short periods at its highest speed. For optimal setting of the carburettor a qualified technician with access to a rev counter should be contacted.

**The recommended max. speed should not be exceeded: 13.500 rpm.**

During a running-in period ( 8 -10 tanks) the maximum speed should be set 6-700 rpm below the recommended maximum speed (= opening the H-needle a further 1/8 turn).



# MAINTENANCE

## Silencer

The silencer is designed to dampen the noise level and to direct the exhaust fumes away from the user. The exhaust fumes are hot and can contain sparks, which can result in fire if the exhaust fumes are directed towards a dry or inflammable material. Some silencers are fitted with a special spark arrest screen. If your machine is fitted with this type of silencer then the screen should be cleaned at least once a week. This is done using a wire brush. **If the screen is damaged in anyway it should be replaced.** If the screen is blocked this will result in the engine overheating and damage to the cylinder and piston.

### NOTE!

Never use a machine with a defective silencer.

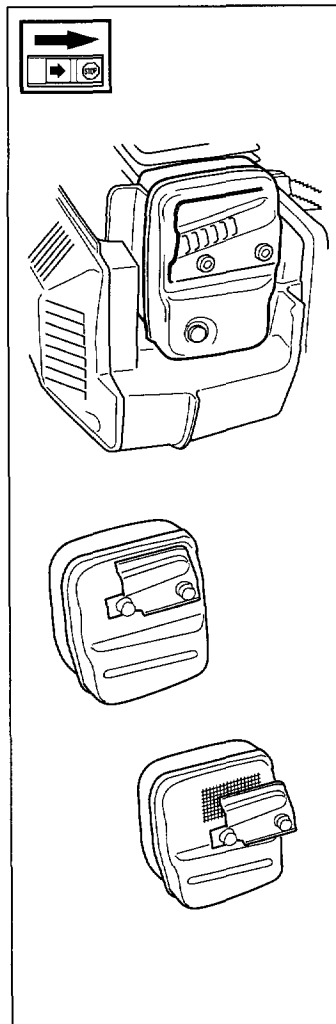

## Air filter

The air filter should be cleaned regularly removing dust and dirt to avoid:

- carburettor malfunction
- starting problems
- reduced engine power
- unnecessary wear to engine parts
- abnormal fuel consumption

Clean the filter after every 25 hours or more regularly if operating conditions are exceptionally dusty.

### Cleaning the air filter

Dismantle the air filter cover and remove the air filter. Wash in clean, warm soapy water. Ensure that the filter is dry before refitting. An air filter used for a long period of time can never be cleaned completely. Therefore it is necessary to replace the filter from time to time with a new filter. A damaged air filter must always be replaced.

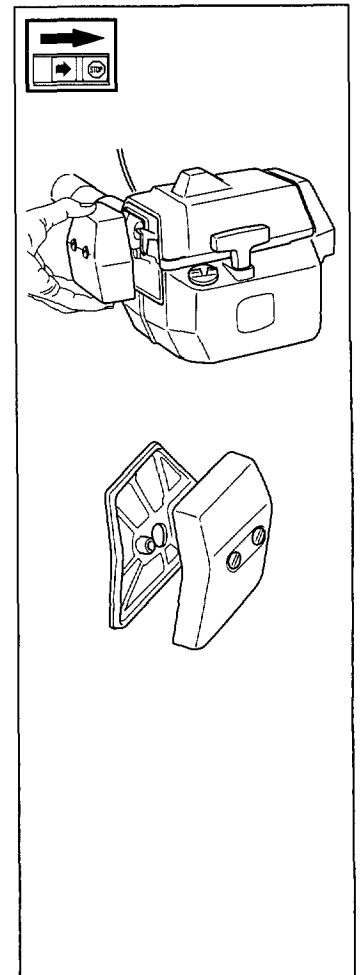

## Cooling system

To maintain as low an operating temperature as possible the engine is equipped with a cooling system. The cooling system consists of:

1. An air intake on the starter unit.
2. Cooling fins on the flywheel.
3. Cooling fins on the cylinder
4. Cylinder cover (leads cold air onto the cylinder).

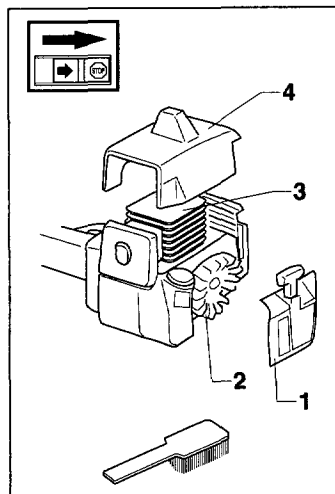

Clean the cooling system using a brush at least once a week, in difficult conditions more often.

**A dirty or blocked cooling system leads to the engine overheating resulting in damage to the cylinder and piston.**

## Angle gear

The angle gear is filled with a sufficient quantity of grease at the factory. However, before using the machine you should check that the angle gear is filled to 3/4 with grease. Use special grease. Normally, the grease does not need to be changed except when the angle gear is repaired.

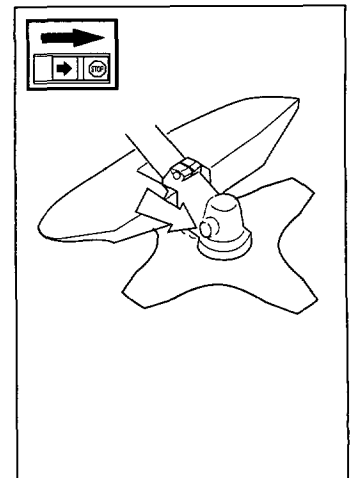

# MAINTENANCE

## Spark plug

The condition of the spark plug is affected by:

- An incorrect carburettor setting.
- An incorrect fuel mixture (too much oil).
- A dirty air filter.

These factors cause deposits on the spark plug electrode that may result in malfunction or starting difficulties.

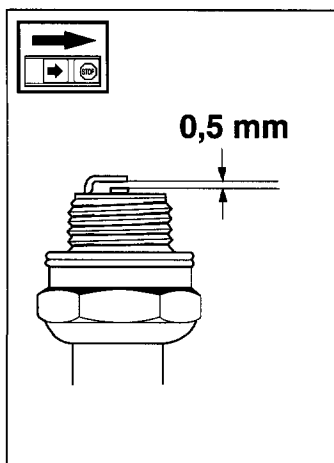

If the machine is low on power, difficult to start or runs poorly while idling always check the spark plug first.

If the spark plug is dirty, clean it and at the same time check that the electrode gap is 0.5 mm. The spark plug should be changed after about one month of operation or earlier if necessary.

NOTE! Always use the recommended type of spark plug. An incorrect spark plug can damage the cylinder/piston.

## Sharpening the clearing blade



**WARNING!**  
Incorrect cutting equipment or an incorrectly sharpened blade increases the risk of kickback.

- Make sure that the blade is well supported when you use the file. Use a 5.5 mm round file with a file holder.
- The sharpening angle is 15°. Every other tooth is sharpened to the right and the intermediate tooth to the left. When the blade has been heavily pitted by stones the upper side of the teeth can, in exceptional cases, need to be dressed using a flat file. In such cases this takes place before sharpening with the round file. Dressing the top side must be carried out equally for all teeth.
- Adjust the setting. This should be 1 mm.

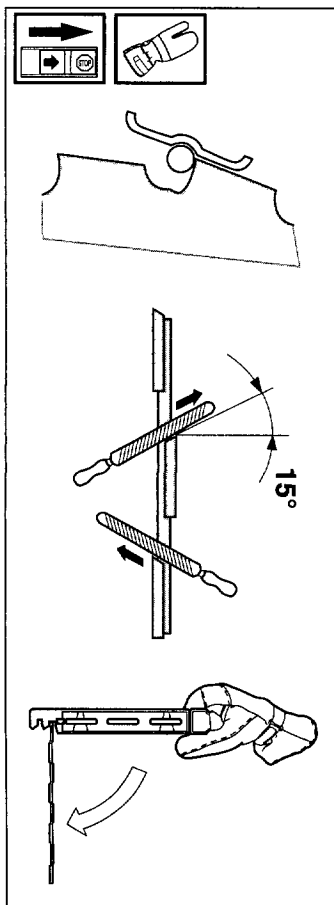

## Maintenance schedule

Below follows some general maintenance instructions.

If you need further information please contact your service workshop.

### Daily maintenance

1. Clean the outside of the clearing saw.
2. Make sure the harness is not damaged.
3. Make sure the throttle trigger lock and the throttle function correctly from a safety point of view.
4. Check that the stop switch functions.
5. Check that the cutting head does not rotate while idling.
6. Clean the air filter. Replace if necessary.
7. Check that the guard is undamaged and not cracked. Replace the guard if it has been exposed to impact or is cracked.
8. Check that the blade is well centred, is sharp, and is not cracked. An uncentred blade causes vibrations that can result in damage to the machine.
9. Check that the trimmer head is undamaged and not cracked. Replace the trimmer head if necessary.
10. Check that the locking nut is tight.
11. Check that the blade's transport guard is intact and that it can be secured correctly.
12. Check that all nuts and screws are tightened.

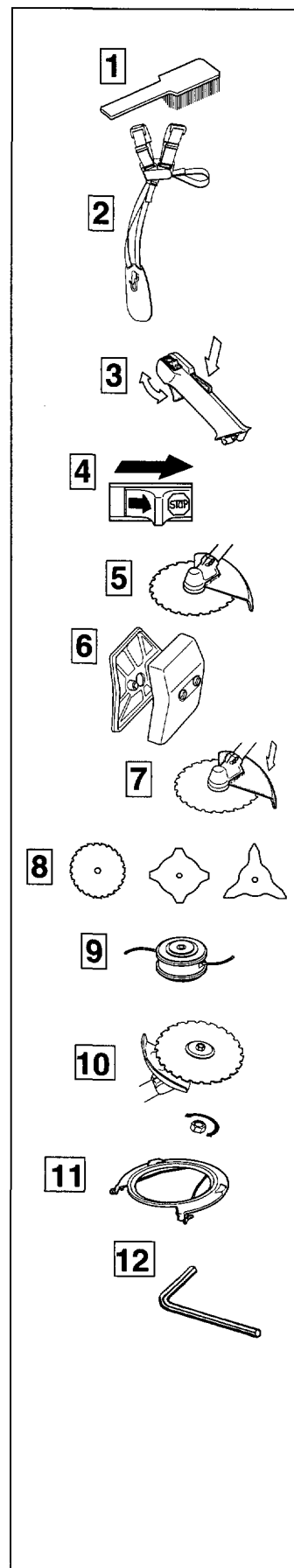

# MAINTENANCE

## Weekly maintenance

1. Check the starter, the starter cord and the return spring.
2. Make sure that the vibration damping elements are not damaged.
3. Clean the outside of the spark plug. Remove and check the electrode gap. Adjust the gap to 0.5 mm or change the spark plug.
4. Clean the cooling fins on the flywheel.
5. Clean or replace the spark arrest screen on the silencer.
6. Clean the carburettor area.
7. Clean the cooling fins on the cylinder and check that the air intake in the starter unit is not blocked.
8. Check that the angle gear is  $\frac{3}{4}$  filled with grease. Fill if necessary using special grease.
9. Clean the air filter.

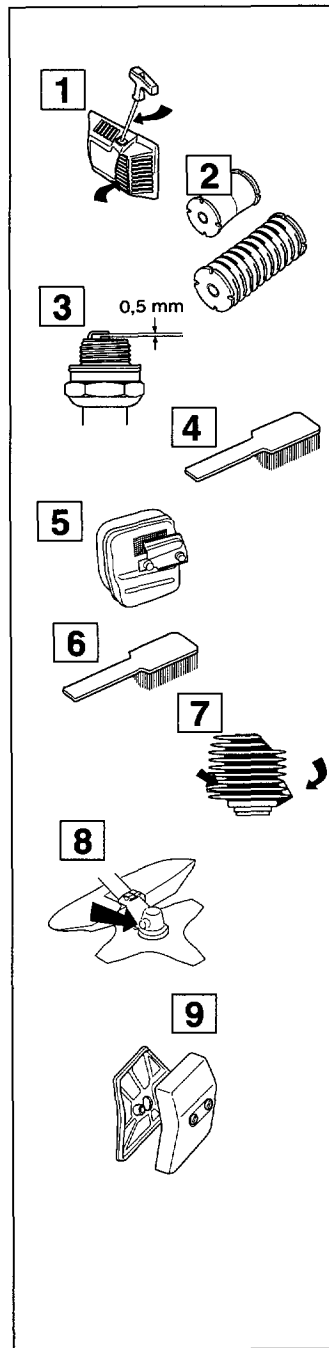

## Monthly maintenance

1. Clean the fuel tank using petrol.
2. Clean the carburettor and the area surrounding it.
3. Clean the fan and the area around it.
4. Check the fuel filter and the fuel pipe, replace if necessary.
5. Check all cables and connections.
6. Check the clutch, clutch springs and the clutch drum with regard to wear. Replace if necessary.
7. Change the spark plug.

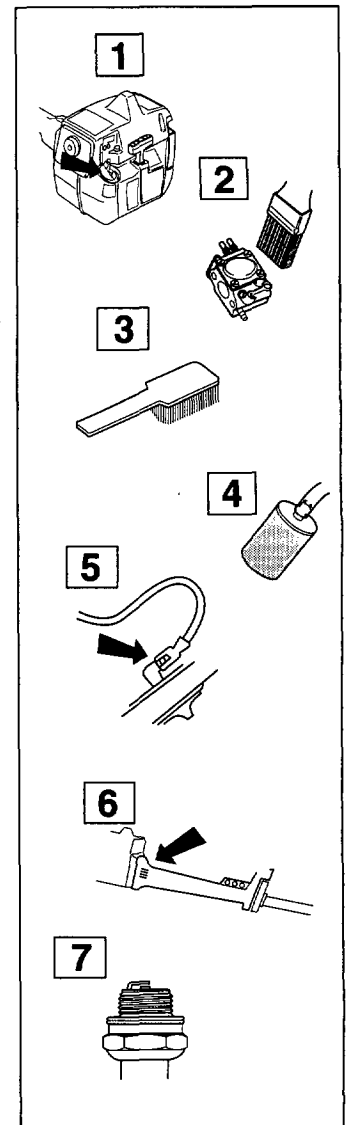

# TECHNICAL DATA

## Technical data

## RS 51

### Engine

Cylinder capacity, cm <sup>3</sup> /cu. inch	50,9/3,1
Cylinder bore, mm/inch	45/1,8
Stroke length, mm/inch	32/1,3
Idling speed, rpm	2 700
Recommended max. speed, rpm	13 500
Speed of output axle, rpm	10 000
Max. engine output, acc. to ISO 8893	2,4 kW/9 600 rpm

### Ignition system

Manufacturer/type of ignition system	EM/ET
Spark plug	Champion RCJ7Y
Electrode gap, mm/inch	0,5/0,02

### Fuel lubrication system

Manufacturer/type of carburettor	Walbro HDA 86
Fuel tank capacity, litres/US pint	0,75/1,6

### Weight

Weight without fuel, cutting tool and guard, kg/LBS	9,1/20,0
---	----------

### Noise levels

Equivalent noise pressure levels at the user's ear, measured according to prEN 31806 and ISO 7917, dB(A).

Trimmer head:	102
Blade:	100

Equivalent noise power levels measured according to prEN 31806 and ISO 10884, dB(A).

Trimmer head:	114
Blade:	111

### Vibration levels

Vibration levels on the handles measured according to prEN 31806 and ISO 7916, m/s<sup>2</sup>

Trimmer head, idling right/left handles rear/front handles:	4,0/4,4
---	---------

Trimmer head, max. speed right/left handles rear/front handles:	2,0/2,2
---	---------

Blade, idling right/left handles:	4,0/4,4
-----------------------------------	---------

Blade, max. speed right/left handles:	2,6/2,1
---------------------------------------	---------

### Cutting equipment

Centre hole in saw blades	Ø 20 mm
Blade/Knife	Opti Ø 200 mm, Ø 225 mm Tripoint Ø 300 mm
Trimmer head	Trimmy SII

### Accessories

Plastic knives

### Type

Polytrim Ø 300 mm

### Cutting attachment guard Ref No.

502 26 34-03