

OWNER'S MANUAL

MODEL NO. HD145H42D

14.5 HP 42 Inch

Lawn Tractor

- Assembly
 - Operation
 - Customer Responsibilities
 - Service and Adjustments
 - Storage
 - Troubleshooting
 - Repair Parts

FILE COPY

For Parts and Service, contact our authorized distributor: call 1-800-849-1297
For Technical Assistance: call 1-800-829-5886

Poulan



SAFETY RULES



Safe Operation Practices for Ride-On Mowers

IMPORTANT: THIS CUTTING MACHINE IS CAPABLE OF AMPUTATING HANDS AND FEET AND THROWING OBJECTS. FAILURE TO OBSERVE THE FOLLOWING SAFETY INSTRUCTIONS COULD RESULT IN SERIOUS INJURY OR DEATH.

I. GENERAL OPERATION

- Read, understand, and follow all instructions in the manual and on the machine before starting.
- Only allow responsible adults, who are familiar with the instructions, to operate the machine.
- Clear the area of objects such as rocks, toys, wire, etc., which could be picked up and thrown by the blade.
- Be sure the area is clear of other people before mowing. Stop machine if anyone enters the area.
- Never carry passengers.
- Do not mow in reverse unless absolutely necessary. Always look down and behind before and while backing.
- Be aware of the mower discharge direction and do not point it at anyone. Do not operate the mower without either the entire grass catcher or the guard in place.
- Slow down before turning.
- Never leave a running machine unattended. Always turn off blades, set parking brake, stop engine, and remove keys before dismounting.
- Turn off blades when not mowing.
- Stop engine before removing grass catcher or unclogging chute.
- Mow only in daylight or good artificial light.
- Do not operate the machine while under the influence of alcohol or drugs.
- Watch for traffic when operating near or crossing roadways.
- Use extra care when loading or unloading the machine into a trailer or truck.

II. SLOPE OPERATION

Slopes are a major factor related to loss-of-control and tipover accidents, which can result in severe injury or death. All slopes require extra caution. If you cannot back up the slope or if you feel uneasy on it, do not mow it.

DO:

- Mow up and down slopes, not across.
- Remove obstacles such as rocks, tree limbs, etc.
- Watch for holes, ruts, or bumps. Uneven terrain could overturn the machine. *Tall grass can hide obstacles.*
- Use slow speed. Choose a low gear so that you will not have to stop or shift while on the slope.
- Follow the manufacturer's recommendations for wheel weights or counterweights to improve stability.
- Use extra care with grass catchers or other attachments. These can change the stability of the machine.
- Keep all movement on the slopes *slow* and *gradual*. Do not make sudden changes in speed or direction.
- Avoid starting or stopping on a slope. If tires lose traction, disengage the blades and proceed slowly *straight* down the slope.

DO NOT:

- *Do not* turn on slopes unless necessary, and then, turn slowly and gradually downhill, if possible.
- *Do not* mow near drop-offs, ditches, or embankments. The mower could suddenly turn over if a wheel is over the edge of a cliff or ditch, or if an edge caves in.
- *Do not* mow on wet grass. Reduced traction could cause sliding.
- *Do not* try to stabilize the machine by putting your foot on the ground.
- *Do not* use grass catcher on steep slopes.

III. CHILDREN

Tragic accidents can occur if the operator is not alert to the presence of children. Children are often attracted to the machine and the mowing activity. *Never* assume that children will remain where you last saw them.

- Keep children out of the mowing area and under the watchful care of another responsible adult.
- Be alert and turn machine off if children enter the area.
- Before and when backing, look behind and *down* for small children.
- Never carry children. They may fall off and be seriously injured or interfere with safe machine operation.
- Never allow children to operate the machine.
- Use extra care when approaching blind corners, shrubs, trees, or other objects that may obscure vision.

IV. SERVICE

- Use extra care in handling gasoline and other fuels. They are flammable and vapors are explosive.
 - Use only an approved container.
 - Never remove gas cap or add fuel with the engine running. Allow engine to cool before refueling. Do not smoke.
 - Never refuel the machine indoors.
 - Never store the machine or fuel container inside where there is an open flame, such as a water heater.
- Never run a machine inside a closed area.
- Keep nuts and bolts, especially blade attachment bolts, tight and keep equipment in good condition.
- Never tamper with safety devices. Check their proper operation regularly.
- Keep machine free of grass, leaves, or other debris build-up. Clean oil or fuel spillage. Allow machine to cool before storing.
- Stop and inspect the equipment if you strike an object. Repair, if necessary, before restarting.
- Never make adjustments or repairs with the engine running.
- Grass catcher components are subject to wear, damage, and deterioration, which could expose moving parts or allow objects to be thrown. Frequently check components and replace with manufacturer's recommended parts, when necessary.
- Mower blades are sharp and can cut. Wrap the blade(s) or wear gloves, and use extra caution when servicing them.
- Check brake operation frequently. Adjust and service as required.



Look for this symbol to point out important safety precautions. It means CAUTION!!! BECOME ALERT!!! YOUR SAFETY IS INVOLVED.



CAUTION: Always disconnect spark plug wire and place wire where it cannot contact spark plug in order to prevent accidental starting when setting up, transporting, adjusting or making repairs.



WARNING



The engine exhaust from this product contains chemicals known to the State of California to cause cancer, birth defects, or other reproductive harm.

CONGRATULATIONS on your purchase of a new tractor. It has been designed, engineered and manufactured to give you the best possible dependability and performance.

Should you experience any problem you cannot easily remedy, please contact your nearest authorized service center/department. We have competent, well-trained technicians and the proper tools to service or repair this tractor.

Please read and retain this manual. The instructions will enable you to assemble and maintain your tractor properly. Always observe the "SAFETY RULES".

MODEL	
NUMBER	HD145H42D
SERIAL	
NUMBER	_____
DATE OF PURCHASE	_____
THE MODEL AND SERIAL NUMBERS WILL BE FOUND ON A PLATE UNDER THE SEAT.	
YOU SHOULD RECORD BOTH SERIAL NUMBER AND DATE OF PURCHASE AND KEEP IN A SAFE PLACE FOR FUTURE REFERENCE.	

CUSTOMER RESPONSIBILITIES

- Read and observe the safety rules.
- Follow a regular schedule in maintaining, caring for and using your tractor.
- Follow the instructions under "Customer Responsibilities" and "Storage" sections of this owner's manual.

PRODUCT SPECIFICATIONS

HORSEPOWER:	14.5
GASOLINE CAPACITY AND TYPE:	2 GALLONS UNLEADED REGULAR
OIL TYPE (API-SF/SG/SH):	SAE 30 (above 32°F) SAE 5W-30 (below 32°F)
OIL CAPACITY:	3.0 PINTS
SPARK PLUG: (GAP: .030")	CHAMPION RJ19LM
VALVE CLEARANCE:	INTAKE: .004" - .006" EXHAUST: .007" - .009"
GROUND SPEED (MPH):	FORWARD: 0.0 - 5.5 REVERSE: 0.0 - 2.3
TIRE PRESSURE:	FRONT: 14 PSI REAR: 10 PSI
CHARGING SYSTEM:	3 AMPS BATTERY 5 AMPS HEADLIGHTS
BATTERY:	AMP/HR: 25 MIN. CCA: 190 CASE SIZE: U1R
BLADE BOLT TORQUE:	30-35 FT. LBS.

WARNING: This tractor is equipped with an internal combustion engine and should not be used on or near any unimproved forest-covered, brush-covered or grass-covered land unless the engine's exhaust system is equipped with a spark arrester meeting applicable local or state laws (if any). If a spark arrester is used, it should be maintained in effective working order by the operator.

A spark arrester for the muffler is available through your nearest authorized service center/department (See REPAIR PARTS section of this manual).

In the state of California the above is required by law (Section 4442 of the California Public Resources Code). Other states may have similar laws. Federal laws apply on federal lands.

TABLE OF CONTENTS

SAFETY RULES	3	MAINTENANCE SCHEDULE	15
PRODUCT SPECIFICATIONS	3	SERVICE AND ADJUSTMENTS	20-25
CUSTOMER RESPONSIBILITIES	3, 15-19	STORAGE	26
WARRANTY	50	TROUBLESHOOTING	27-28
ASSEMBLY	6-9	REPAIR PARTS - TRACTOR	30-47
OPERATION	10-14	PARTS ORDERING/SERVICE	BACK COVER

INDEX

A		Engine:		Options:	
Adjustments:		Air Filter	18	Spark Arrester	3,40
Brake	22	Air Screen	16		
Carburetor	25	Cooling Fins	18	P	
Mower		Oil Change	17	Parking Brake	11-12
Front-To-Back	21	Oil Level	13	Parts Bag	5
Side-To-Side	21	Oil Type	13,17	Parts, Replacement/Repair	30-47
Throttle Control Cable	24	Preparation	13	Product Specifications	3
Air Filter, Engine	18	Starting	14		
Air Screen, Engine	18	Storage	26	R	
Assembly	6-9			Repair Parts	30-47
B		F		S	
Battery:		Filter:		Safety Rules	3
Charging	7	Air Filter	18	Seat	7
Cleaning	17	Fuel	19	Service and Adjustments	20-25
Starting with Weak Battery	23	Fuel:		Carburetor	25
Storage	26	Type	13	Fuse	24
Terminals	17	Storage	26	Hood Removal/Installation	24
Belt:		Fuse	24	Motion Drive Belt	
Motion Drive				Removal/Replacement	22
Removal/Replacement	22	H		Mower Belt(s)	
Mower Belt(s)		Hood Removal/Installation	24	Removal/Replacement	22
Removal/Replacement	22	L		Mower Adjustment	
Blade:		Leveling Mower Deck	21	Front-to-Back	21
Sharpening	16	Lubrication:		Side-to-Side	21
Replacement	16	Chart	15	Mower Removal/Installation	20
Brake Adjustment	22	Engine	17	Tire Care	7,16,23
C		M		Slope Guide Sheet	51
Carburetor Adjustment	25	Maintenance Schedule	15	Spark Plug(s)	19
Controls, Tractor	11	Mower:		Specifications	2
Customer Responsibilities	15-19	Adjustment, Front-to-Back	21	Starting the Engine	13-14
Engine:		Adjustment, Side-to-Side	21	Steering Wheel	6,23
Air Filter	18	Blade Replacement	16	Stopping the Tractor	12
Air Screen	18	Blade Sharpening	16	Storage	26
Cooling Fins	18	Cutting Height	12		
Engine Oil	13,17	Installation	20	T	
Fuel Filter	19	Operation	13	Throttle Control Cable Adjustment	24
Spark Plug(s)	19	Removal	20	Tires	7,16,23
Tractor:		Mowing Tips	14	Troubleshooting Chart	27-28
Battery	17	Muffler	19	Transaxle	30-47
Blade	16	Spark Arrester	3,40		
Lubrication Chart	15	O		W	
Maintenance Schedule	15	Oil:		Warranty	3
Tire Care	7,16,23	Cold Weather Conditions	13,17	Wiring Diagram	30
Transaxle	17	Engine	17	Wiring Schematic	29
Cutting Height, Mower	12	Storage	26		
E		Operation	11-14		
Electrical:		Operating Mower	13		
Interlocks and Relays	24				
Schematic	29				
Wiring Diagram	30				

CONTENTS OF HARDWARE PACK

Parts Bag contents shown full size

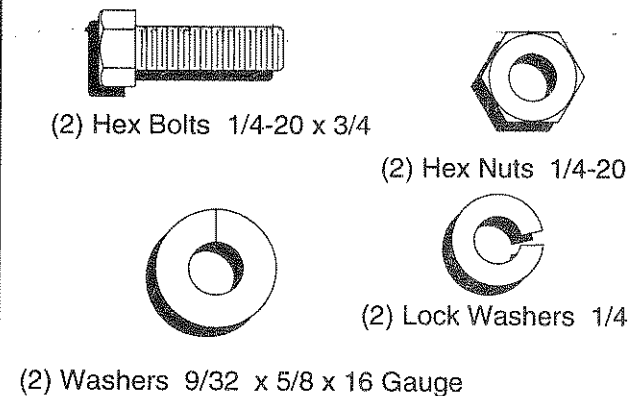
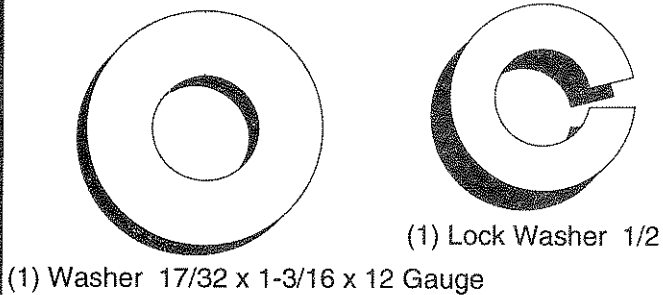
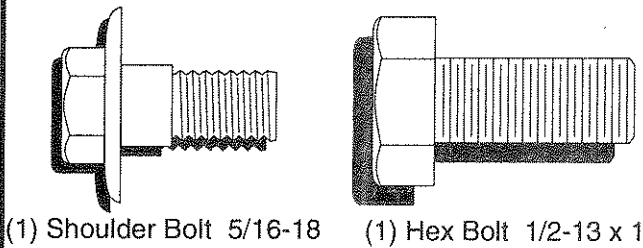
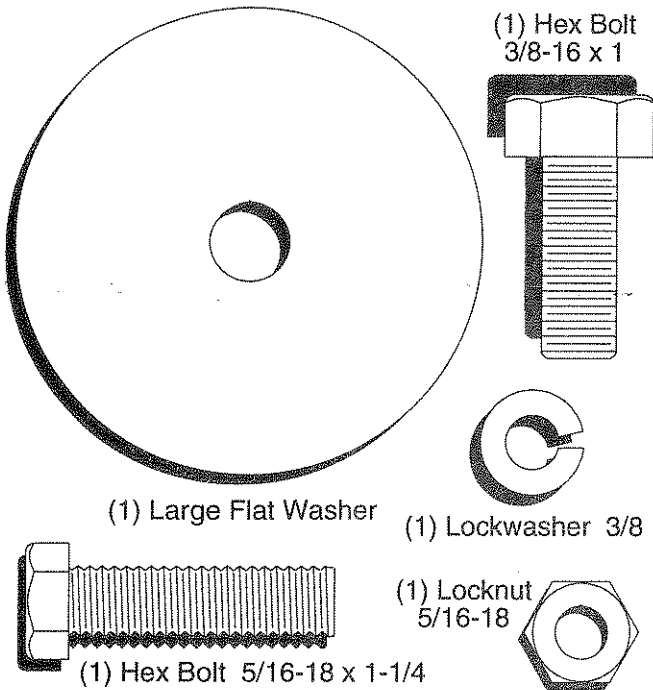

Parts packed separately in carton

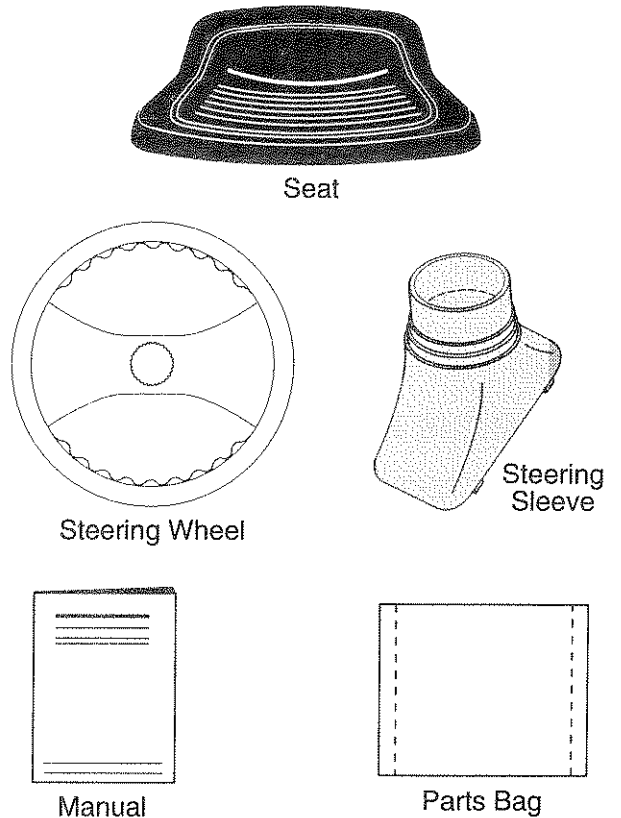

Parts bag contents not shown full size

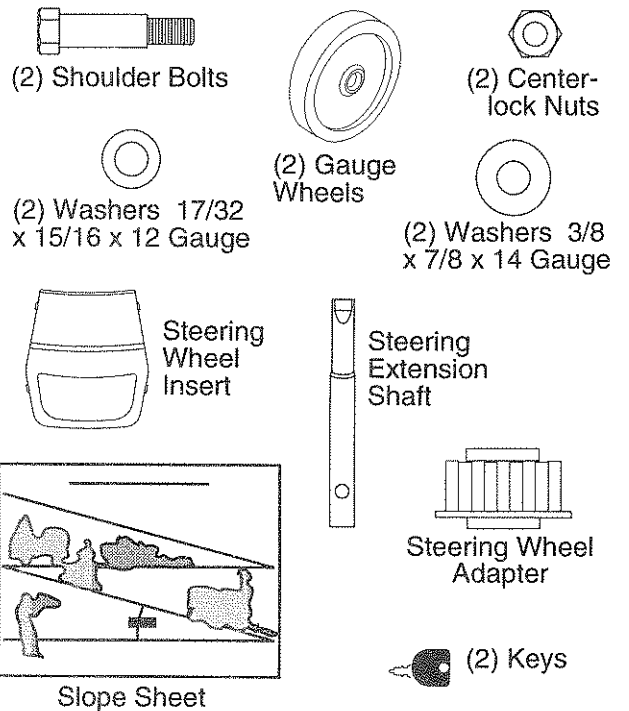

ASSEMBLY

Your new tractor has been assembled at the factory with exception of those parts left unassembled for shipping purposes. To ensure safe and proper operation of your tractor all parts and hardware you assemble must be tightened securely. Use the correct tools as necessary to insure proper tightness.

TOOLS REQUIRED FOR ASSEMBLY

A socket wrench set will make assembly easier. Standard wrench sizes are listed.

- (1) 3/4" Socket w/drive ratchet Utility knife
- (2) 7/16" wrenches Tire pressure gauge
- (2) 1/2" wrenches
- (1) 9/16" wrench

When right or left hand is mentioned in this manual, it means when you are in the operating position (seated behind the steering wheel).

TO REMOVE TRACTOR FROM CARTON

UNPACK CARTON

- Remove all accessible loose parts and parts cartons from carton (See page 5).
- Cut, from top to bottom, along lines on all four corners of carton, and lay panels flat.
- Check for any additional loose parts or cartons and remove.

BEFORE ROLLING TRACTOR OFF SKID

ATTACH STEERING WHEEL (See Fig. 1)

ASSEMBLE EXTENSION SHAFT AND BOOT

- Slide extension shaft onto lower steering shaft. Align mounting holes in extension and lower shafts and install 5/16 hex bolt and locknut. Tighten securely.

IMPORTANT: TIGHTEN BOLT AND NUT SECURELY TO 18-22 FT. LBS TORQUE.

- Place tabs of steering boot over tab slots in dash and push down to secure.

INSTALL STEERING WHEEL

- Position front wheels of the tractor so they are pointing straight forward.
- Slide steering wheel adapter onto steering shaft extension.
- Position steering wheel so cross bars are horizontal (left to right) and slide inside boot and onto adapter.
- Assemble large flat washer, 3/8 lock washer, 3/8 hex bolt and tighten securely.
- Snap steering wheel insert into center of steering wheel.
- Remove protective materials from tractor hood and grill.

IMPORTANT: CHECK FOR AND REMOVE ANY STAPLES IN SKID THAT MAY PUNCTURE TIRES WHERE TRACTOR IS TO ROLL OFF SKID.

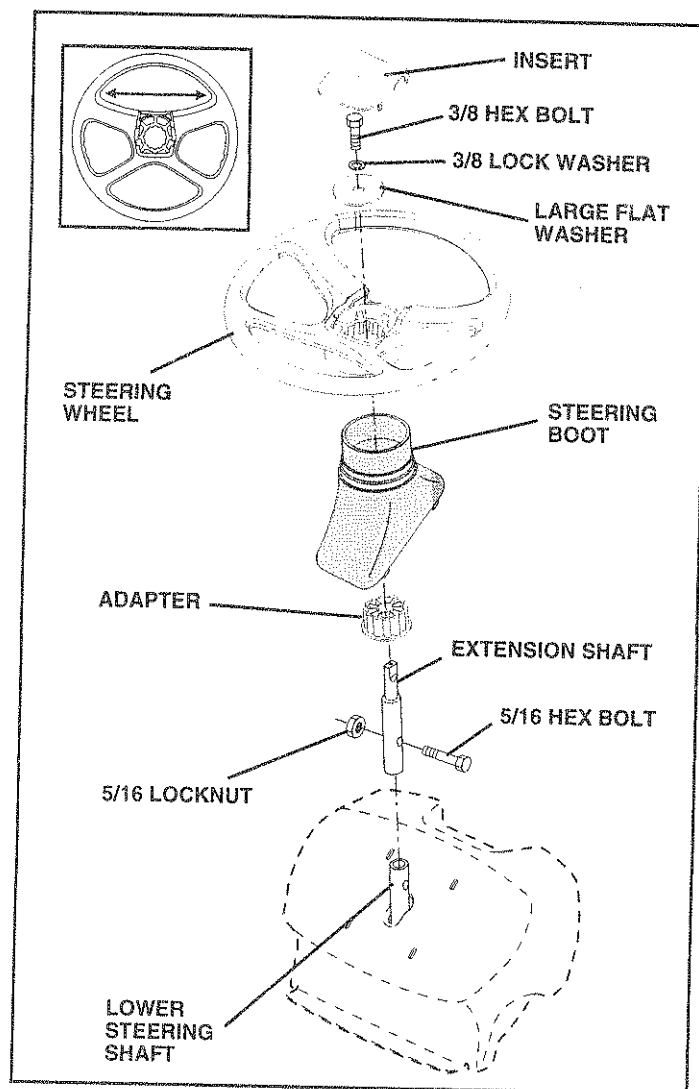

FIG. 1

TO ROLL TRACTOR OFF SKID (See Operation section for location and function of controls)

- Press lift lever plunger and raise attachment lift lever to its highest position.
- Release parking brake by depressing clutch/brake pedal.
- Place freewheel control in freewheeling position to disengage transmission (See "TO TRANSPORT" in the Operation section of this manual).
- Roll tractor backwards off skid.
- Remove banding holding discharge guard up against tractor.

ASSEMBLY

HOW TO SET UP YOUR TRACTOR

CONNECT BATTERY (See Figs. 2 and 3)



CAUTION: Do not short battery terminals by allowing a wrench or any other object to contact both terminals at the same time. Before connecting battery, remove metal bracelets, wristwatch bands, etc.

Positive terminal must be connected first to prevent sparking from accidental grounding.

- Remove cardboard packing from seat pan and lift seat pan to raised position.
- Open battery box door and remove protective plastic.
- Remove terminal protective caps and discard.
- If this battery is put into service after month and year indicated on label (label located between terminals) charge battery for minimum of one hour at 6-10 amps.
- First connect RED battery cable to positive (+) terminal with hex bolt, flat washer, lock washer and hex nut as shown. Tighten securely.
- Connect BLACK grounding cable to negative (-) terminal with remaining hex bolt, flat washer, lock washer and hex nut. Tighten securely.
- Close battery box door.

Open battery box door for:

- Inspection for secure connections (to tighten hardware).
- Inspection for corrosion.
- Testing battery.
- Jumping (if required).
- Periodic charging .

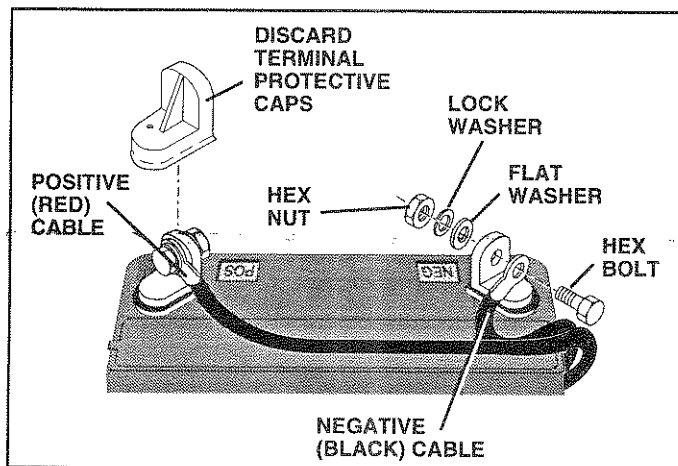

FIG. 2

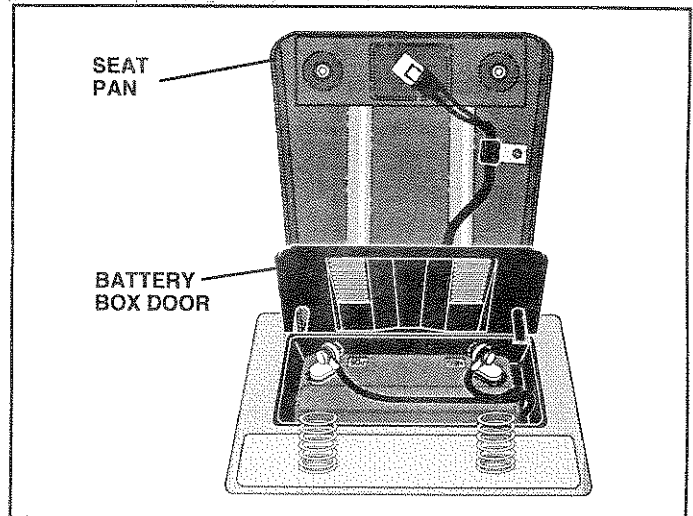

FIG. 3

INSTALL SEAT (See Fig. 4)

Adjust seat before tightening adjustment bolt.

- Remove cardboard packing on seat pan.
- Place seat on seat pan and assemble shoulder bolt.
- Assemble adjustment bolt, lock washer and flat washer loosely. Do not tighten.
- Tighten shoulder bolt securely.
- Lower seat into operating position and sit on seat.
- Slide seat until a comfortable position is reached which allows you to press clutch/brake pedal all the way down.
- Get off seat without moving its adjusted position.
- Raise seat and tighten adjustment bolt securely.

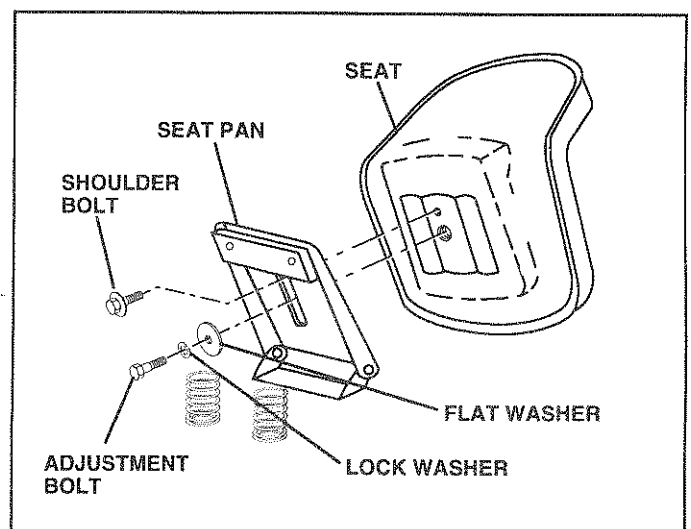

FIG. 4

ASSEMBLY

ASSEMBLE GAUGE WHEELS TO MOWER DECK (See Fig. 5)

The gauge wheels are designed to keep the mower deck in proper position when operating mower. Be sure they are properly adjusted to ensure optimum mower performance.

- Assemble gauge wheels with tractor on a flat level surface.
- Adjust mower to desired cutting height (See "TO ADJUST MOWER CUTTING HEIGHT" in the Operation section of this manual).
- With mower in desired height of cut position, gauge wheels should be assembled so they are slightly off the ground. Install gauge wheel in appropriate hole with shoulder bolt, 17/32 washer, 3/8 washer, and 3/8-16 locknut and tighten securely.
- Repeat for opposite side installing gauge wheel in same adjustment hole.

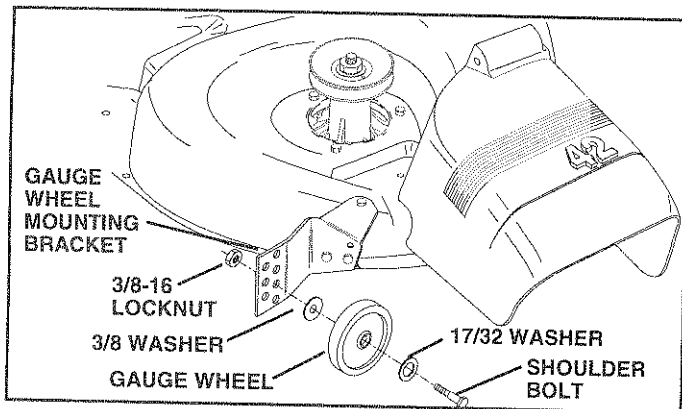

FIG. 5

CHECK TIRE PRESSURE

The tires on your tractor were overinflated at the factory for shipping purposes. Correct tire pressure is important for best cutting performance.

- Reduce tire pressure to PSI shown in "PRODUCT SPECIFICATIONS" on page 3 of this manual.

CHECK DECK LEVELNESS

For best cutting results, mower housing should be properly leveled. See "TO LEVEL MOWER HOUSING" in the Service and Adjustments section of this manual.

CHECK FOR PROPER POSITION OF ALL BELTS

See the figures that are shown for replacing motion and mower blade drive belts in the Service and Adjustments section of this manual. Verify that the belts are routed correctly.

CHECK BRAKE SYSTEM

After you learn how to operate your tractor, check to see that the brake is properly adjusted. See "TO ADJUST BRAKE" in the Service and Adjustments section of this manual.

✓ CHECKLIST

BEFORE YOU OPERATE AND ENJOY YOUR NEW TRACTOR, WE WISH TO ASSURE THAT YOU RECEIVE THE BEST PERFORMANCE AND SATISFACTION FROM THIS QUALITY PRODUCT.

PLEASE REVIEW THE FOLLOWING CHECKLIST:

- ✓ All assembly instructions have been completed.
- ✓ No remaining loose parts in carton.
- ✓ Battery is properly prepared and charged. (Minimum 1 hour at 6 amps).
- ✓ Seat is adjusted comfortably and tightened securely.
- ✓ All tires are properly inflated. (For shipping purposes, the tires were overinflated at the factory).
- ✓ Be sure mower deck is properly leveled side-to-side/front-to-rear for best cutting results. (Tires must be properly inflated for leveling).
- ✓ Check mower and drive belts. Be sure they are routed properly around pulleys and inside all belt keepers.
- ✓ Check wiring. See that all connections are still secure and wires are properly clamped.
- ✓ Before driving tractor, be sure freewheel control is in drive position.

WHILE LEARNING HOW TO USE YOUR TRACTOR, PAY EXTRA ATTENTION TO THE FOLLOWING IMPORTANT ITEMS:

- ✓ Engine oil is at proper level.
- ✓ Fuel tank is filled with fresh, clean, regular unleaded gasoline.
- ✓ Become familiar with all controls - their location and function. Operate them before you start the engine.
- ✓ Be sure brake system is in safe operating condition.
- ✓ It is important to purge the transmission before operating your tractor for the first time. Follow proper starting and transmission purging instructions (See "TO START ENGINE" and "PURGE TRANSMISSION" in the Operation section of this manual).

OPERATION

These symbols may appear on your tractor or in literature supplied with the product. Learn and understand their meaning.

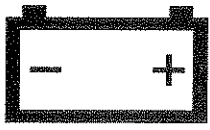

BATTERY

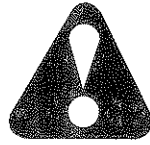

CAUTION OR WARNING



REVERSE



FORWARD



FAST



SLOW



ENGINE ON



ENGINE OFF



OIL PRESSURE



CLUTCH



LIGHTS ON



LIGHTS OFF



FUEL



CHOKE



MOWER HEIGHT

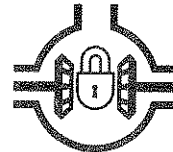

DIFFERENTIAL LOCK



PARKING BRAKE LOCKED



UNLOCKED



MOWER LIFT

R

REVERSE

N

NEUTRAL

H

HIGH

L

LOW

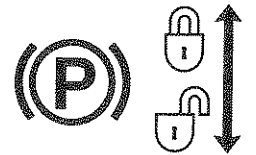

PARKING BRAKE



ATTACHMENT CLUTCH ENGAGED

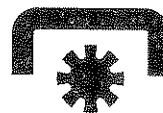

ATTACHMENT CLUTCH DISENGAGED

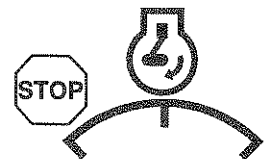

IGNITION

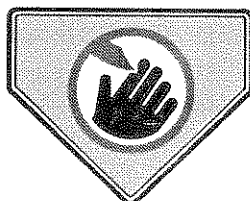

DANGER, KEEP HANDS AND FEET AWAY

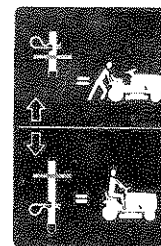
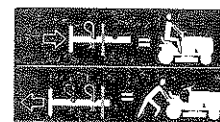

HYDROSTATIC FREE WHEEL
(Hydro Models only)

OPERATION

KNOW YOUR TRACTOR

READ THIS OWNER'S MANUAL AND SAFETY RULES BEFORE OPERATING YOUR TRACTOR

Compare the illustrations with your tractor to familiarize yourself with the locations of various controls and adjustments. Save this manual for future reference.

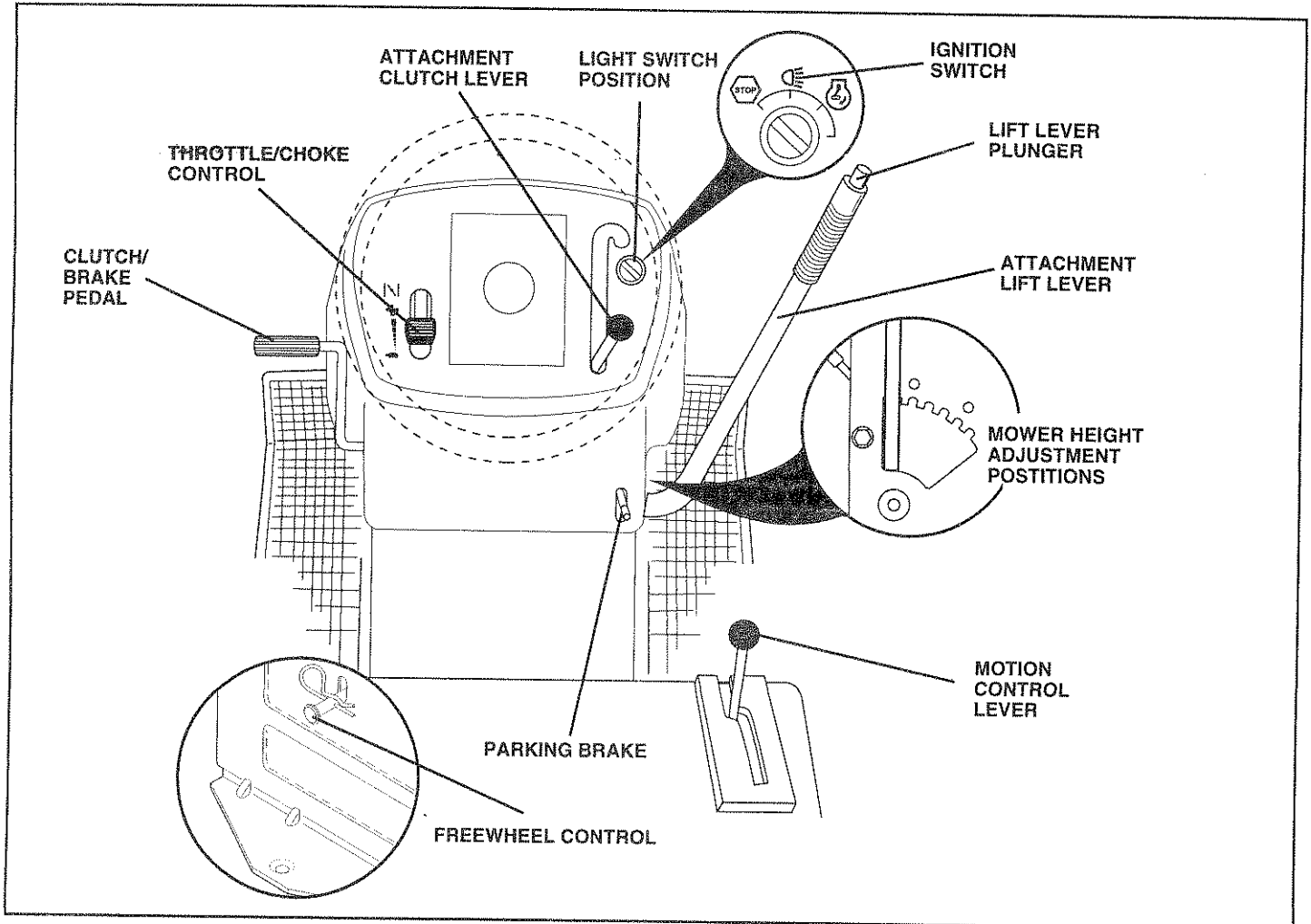

FIG. 6

Our tractors conform to the safety standards of the American National Standards Institute.

ATTACHMENT CLUTCH LEVER: Used to engage the mower blades, or other attachments mounted to your tractor.

LIGHT SWITCH: Turns the headlights on and off.

THROTTLE/CHOKE CONTROL - Used for starting and controlling engine speed.

CLUTCH/BRAKE PEDAL: Used for declutching and braking the tractor and starting the engine.

PARKING BRAKE: Locks clutch/brake pedal into the brake position.

MOTION CONTROL LEVER: Selects the speed and direction of tractor.

ATTACHMENT LIFT LEVER - Used to raise and lower the mower deck or other attachments mounted to your tractor.

LIFT LEVER PLUNGER: Used to release attachment lift lever when changing its position.

IGNITION SWITCH: Used for starting and stopping the engine.

FREEWHEEL CONTROL - Disengages transmission for pushing or slowly towing the tractor with the engine off.

OPERATION



The operation of any tractor can result in foreign objects thrown into the eyes, which can result in severe eye damage. Always wear safety glasses or eye shields while operating your tractor or performing any adjustments or repairs. We recommend a wide vision safety mask over the spectacles or standard safety glasses.

HOW TO USE YOUR TRACTOR

TO SET PARKING BRAKE (See Fig. 7)

Your tractor is equipped with an operator presence sensing switch. When engine is running, any attempt by the operator to leave the seat without first setting the parking brake will shut off the engine.

- Depress clutch/brake pedal into full "BRAKE" position and hold.
- Place parking brake lever in "ENGAGED" position and release pressure from clutch/brake pedal. Pedal should remain in "BRAKE" position. Make sure parking brake will hold tractor secure.

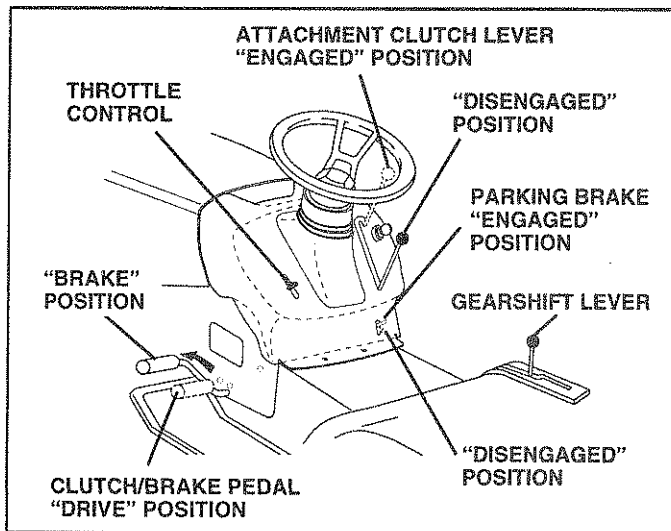

FIG. 7

STOPPING (See Fig. 7)

MOWER BLADES -

- Move attachment clutch lever to "DISENGAGED" position.

GROUND DRIVE -

- Depress clutch/brake pedal into full "BRAKE" position.
- Move motion control lever to neutral (N) position.

IMPORTANT: THE MOTION CONTROL LEVER DOES NOT RETURN TO NEUTRAL (N) POSITION WHEN THE CLUTCH/BRAKE PEDAL IS DEPRESSED.

ENGINE -

- Move throttle control to slow position.

NOTE: Failure to move throttle control to slow position and allowing engine to idle before stopping may cause engine to "backfire".

- Turn ignition key to "OFF" position and remove key. Always remove key when leaving tractor to prevent unauthorized use.
- Never use choke to stop engine.

NOTE: Under certain conditions when tractor is standing idle with the engine running, hot engine exhaust gases may cause "browning" of grass. To eliminate this possibility, always stop engine when stopping tractor on grass areas.



CAUTION: Always stop tractor completely, as described above, before leaving the operator's position; to empty grass catcher, etc.

TO USE THROTTLE CONTROL (See Fig. 7)

Always operate engine at full throttle.

- Operating engine at less than full throttle reduces the battery charging rate.
- Full throttle offers the best bagging and mower performance.

TO MOVE FORWARD AND BACKWARD (See Fig. 7)

The direction and speed of movement is controlled by the motion control lever.

- Start tractor with motion control lever in neutral (N) position.
- Release parking brake and clutch/brake pedal.
- Slowly move motion control lever to desired position.

TO ADJUST MOWER CUTTING HEIGHT (See Fig. 6)

The position of the attachment lift lever determines the cutting height.

- Grasp lift lever.
- Press plunger with thumb and move lever to desired position.

The cutting height range is approximately 1-1/2 to 4". The heights are measured from the ground to the blade tip with the engine not running. These heights are approximate and may vary depending upon soil conditions, height of grass and types of grass being mowed.

- The average lawn should be cut to approximately 2-1/2 inches during the cool season and to over 3 inches during hot months. For healthier and better looking lawns, mow often and after moderate growth.
- For best cutting performance, grass over 6 inches in height should be mowed twice. Make the first cut relatively high; the second to desired height.

OPERATION

TO OPERATE MOWER (See Fig. 8)

Your tractor is equipped with an operator presence sensing switch. Any attempt by the operator to leave the seat with the engine running and the attachment clutch engaged will shut off the engine.

- Select desired height of cut.
- Lower mower with attachment lift control.
- Start mower blades by engaging attachment clutch control.
- TO STOP MOWER BLADES - disengage attachment clutch control.



CAUTION: Do not operate the mower without either the entire grass catcher, on mowers so equipped, or the discharge guard in place.

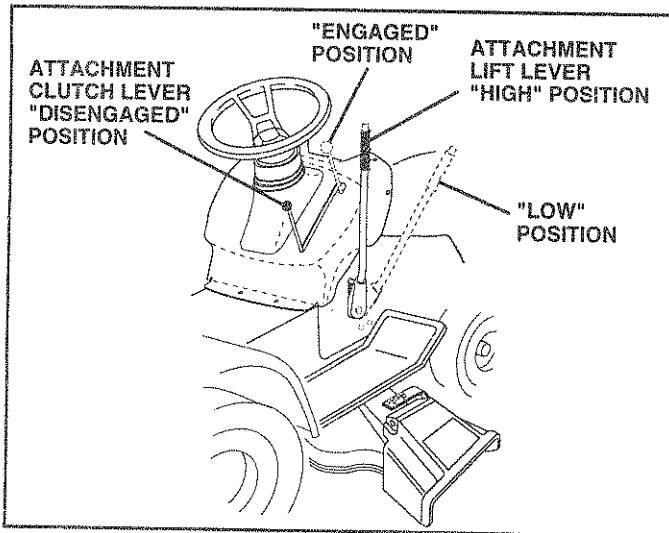

FIG. 8

TO OPERATE ON HILLS



CAUTION: Do not drive up or down hills with slopes greater than 15° and do not drive across any slope.

- Choose the slowest speed before starting up or down hills.
- Avoid stopping or changing speed on hills.
- If slowing is necessary, move throttle control lever to slower position.
- If stopping is absolutely necessary, push clutch/brake pedal quickly to brake position and engage parking brake.
- Move motion control lever to neutral (N) position.

IMPORTANT: THE MOTION CONTROL LEVER DOES NOT RETURN TO NEUTRAL (N) POSITION WHEN THE CLUTCH/BRAKE PEDAL IS DEPRESSED.

- To restart movement, slowly release parking brake and clutch/brake pedal.
- Slowly move motion control lever to slowest setting.
- Make all turns slowly.

TO TRANSPORT (See Figs. 9 and 6)

When pushing or towing your tractor, be sure to disengage transmission by placing freewheel control in freewheeling position. Free wheel control is located at the rear drawbar of tractor.

- Raise attachment lift to highest position with attachment lift control.
- Pull freewheel control knob out and hold in position by inserting retainer spring into forward hole of control rod.
- Do not push or tow tractor at more than two (2) MPH.
- To reengage transmission, reverse above procedure.

NOTE: To protect hood from damage when transporting your tractor on a truck or a trailer, be sure hood is closed and secured to tractor. Use an appropriate means of tying hood to tractor (rope, cord, etc.).

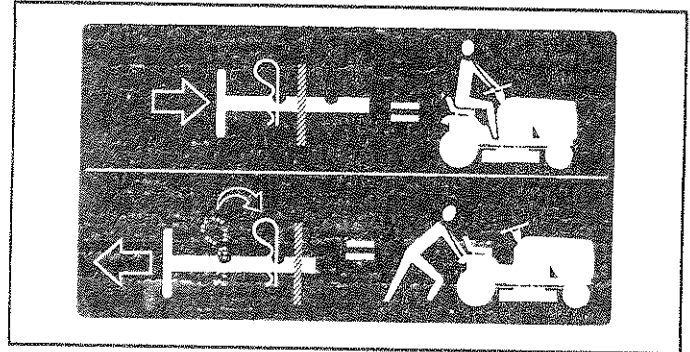

FIG. 9

BEFORE STARTING THE ENGINE

CHECK ENGINE OIL LEVEL (See Fig. 12)

- The engine in your tractor has been shipped, from the factory, already filled with summer weight oil.
- Check engine oil with tractor on level ground.
- Remove oil fill cap/dipstick and wipe clean, reinsert the dipstick and screw cap tight, wait for a few seconds, remove and read oil level. If necessary, add oil until "FULL" mark on dipstick is reached. Do not overfill.
- For cold weather operation you should change oil for easier starting (See "OIL VISCOSITY CHART" in the Customer Responsibilities section of this manual).
- To change engine oil, see the Customer Responsibilities section in this manual.

OPERATION

ADD GASOLINE

- Fill fuel tank. Use fresh, clean, regular unleaded gasoline with a minimum of 87 octane. (Use of leaded gasoline will increase carbon and lead oxide deposits and reduce valve life). Do not mix oil with gasoline. Purchase fuel in quantities that can be used within 30 days to assure fuel freshness.

IMPORTANT: WHEN OPERATING IN TEMPERATURES BELOW 32°F(0°C), USE FRESH, CLEAN WINTER GRADE GASOLINE TO HELP INSURE GOOD COLD WEATHER STARTING.

WARNING: Experience indicates that alcohol blended fuels (called gasohol or using ethanol or methanol) can attract moisture which leads to separation and formation of acids during storage. Acidic gas can damage the fuel system of an engine while in storage. To avoid engine problems, the fuel system should be emptied before storage of 30 days or longer. Drain the gas tank, start the engine and let it run until the fuel lines and carburetor are empty. Use fresh fuel next season. See Storage Instructions for additional information. Never use engine or carburetor cleaner products in the fuel tank or permanent damage may occur.



CAUTION: Fill to bottom of gas tank filler neck. Do not overfill. Wipe off any spilled oil or fuel. Do not store, spill or use gasoline near an open flame.

TO START ENGINE (See Fig. 7)

When starting the engine for the first time or if the engine has run out of fuel, it will take extra cranking time to move fuel from the tank to the engine.

- Be sure freewheel control is in the transmission engaged position.
- Sit on seat in operating position, depress clutch/brake pedal and set parking brake.
- Place motion control lever in neutral (N) position.
- Move attachment clutch to "DISENGAGED" position.
- Move throttle control to choke position.

Note: Before starting, read the warm and cold starting procedures below.

- Insert key into ignition and turn key clockwise to "START" position and release key as soon as engine starts. Do not run starter continuously for more than fifteen seconds per minute. If the engine does not start after several attempts, move throttle control to fast position, wait a few minutes and try again. If engine still does not start, move the throttle control back to the choke position and retry.

WARM WEATHER STARTING (50° F and above)

- When engine starts, move the throttle control to the fast position.
- The attachments and ground drive can now be used. If the engine does not accept the load, restart the engine and allow it to warm up for one minute using the choke as described above.

COLD WEATHER STARTING (50° F and below)

- When engine starts, allow engine to run with the throttle control in the choke position until the engine runs roughly, then move throttle control to fast position. This may require an engine warm-up period from several seconds to several minutes, depending on the temperature.

HYDROSTATIC TRANSMISSION WARM UP

- Before driving the unit in cold weather, the transmission should be warmed up as follows:
 - Be sure the tractor is on level ground.
 - Place the motion control lever in neutral. Release the parking brake and let the clutch/brake slowly return to operating position.
 - Allow one minute for transmission to warm up. This can be done during the engine warm up period.
- The attachments can also be used during the engine warm-up period after the transmission has been warmed up.

NOTE: If at a high altitude (above 3000 feet) or in cold temperatures (below 32 F) the carburetor fuel mixture may need to be adjusted for best engine performance. See "TO ADJUST CARBURETOR" in the Service and Adjustments section of this manual.

OPERATION

PURGE TRANSMISSION



CAUTION: Never engage or disengage freewheel lever while the engine is running.

To ensure proper operation and performance, it is recommended that the transmission be purged before operating tractor for the first time. This procedure will remove any trapped air inside the transmission which may have developed during shipping of your tractor.

IMPORTANT: SHOULD YOUR TRANSMISSION REQUIRE REMOVAL FOR SERVICE OR REPLACEMENT, IT SHOULD BE PURGED AFTER REINSTALLATION BEFORE OPERATING THE TRACTOR.

- Place tractor safely on level surface with engine off and parking brake set.
- Disengage transmission by placing freewheel control in freewheeling position (See "TO TRANSPORT" in this section of manual).
- Sitting in the tractor seat, start engine. After the engine is running, move throttle control to slow position. With motion control lever in neutral (N) position, slowly disengage clutch/brake pedal.
- Move motion control lever to full forward position and hold for five (5) seconds. Move lever to full reverse position and hold for five (5) seconds. Repeat this procedure three (3) times.

NOTE: During this procedure there will be no movement of drive wheels. The air is being removed from hydraulic drive system.

- Move motion control lever to neutral (N) position. Shut-off engine and set parking brake.
- Engage transmission by placing freewheel control in driving position (See "TO TRANSPORT" in this section of manual).
- Sitting in the tractor seat, start engine. After the engine is running, move throttle control to half (1/2) speed. With motion control lever in neutral (N) position, slowly disengage clutch/brake pedal.
- Slowly move motion control lever forward, after the tractor moves approximately five (5) feet, slowly move motion control lever to reverse position. After the tractor moves approximately five (5) feet return the motion control lever to the neutral (N) position. Repeat this procedure with the motion control lever three (3) times.
- Your tractor is now purged and now ready for normal operation.

MOWING TIPS

- Tire chains cannot be used when the mower housing is attached to tractor.
- Mower should be properly leveled for best mowing performance. See "TO LEVEL MOWER HOUSING" in the Service and Adjustments section of this manual.
- The left hand side of mower should be used for trimming.
- Drive so that clippings are discharged onto the area that has been cut. Have the cut area to the right of the tractor. This will result in a more even distribution of clippings and more uniform cutting.
- When mowing large areas, start by turning to the right so that clippings will discharge away from shrubs, fences, driveways, etc. After one or two rounds, mow in the opposite direction making left hand turns until finished (See Fig. 10).
- If grass is extremely tall, it should be mowed twice to reduce load and possible fire hazard from dried clippings. Make first cut relatively high; the second to the desired height.
- Do not mow grass when it is wet. Wet grass will plug mower and leave undesirable clumps. Allow grass to dry before mowing.
- Always operate engine at full throttle when mowing to assure better mowing performance and proper discharge of material. Regulate ground speed by selecting a low enough gear to give the mower cutting performance as well as the quality of cut desired.
- When operating attachments, select a ground speed that will suit the terrain and give best performance of the attachment being used.

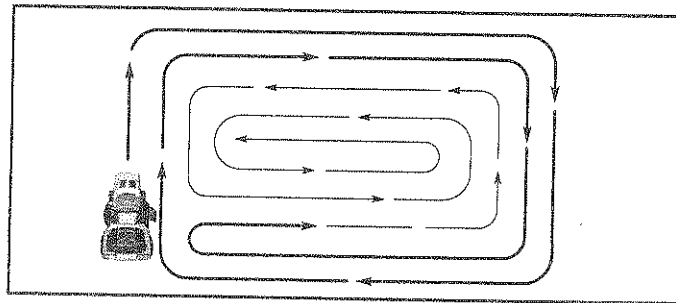

FIG. 10

CUSTOMER RESPONSIBILITIES

MAINTENANCE SCHEDULE FILL IN DATES AS YOU COMPLETE REGULAR SERVICE		SERVICE INTERVALS							SERVICE DATES				
		BEFORE EACH USE	EVERY 8 HOURS	EVERY 25 HOURS	EVERY 50 HOURS	EVERY 100 HOURS	EVERY SEASON	BEFORE STORAGE					
TRACTOR	Check Brake Operation	✓	✓										
	Check Tire Pressure	✓	✓										
	Check for Loose Fasteners	✓				✓ ₇		✓					
	Sharpen/Replace Mower Blades			✓ ₄									
	Lubrication Chart			✓				✓					
	Check Battery Level/Recharge			✓ ₆									
	Clean Battery and Terminals			✓				✓					
	Check Transaxle Cooling			✓									
	Adjust Blade Belt(s) Tension					✓ ₅							
	Adjust Motion Drive Belt(s) Tension					✓ ₅							
ENGINE	Check Engine Oil Level	✓	✓										
	Change Engine Oil			✓ _{1,2,3}				✓					
	Clean Air Filter			✓ ₂									
	Clean Air Screen			✓ ₂									
	Inspect Muffler/Spark Arrestor				✓								
	Replace Oil Filter (If equipped)					✓ _{1,2}							
	Clean Engine Cooling Fins					✓ ₂							
	Replace Spark Plug					✓		✓					
	Replace Air Filter Paper Cartridge					✓ ₂							
	Replace Fuel Filter							✓					

- 1 - Change more often when operating under a heavy load or in high ambient temperatures.
- 2 - Service more often when operating in dirty or dusty conditions.
- 3 - If equipped with oil filter, change oil every 50 hours.
- 4 - Replace blades more often when mowing in sandy soil.
- 5 - If equipped with adjustable system.
- 6 - Not required if equipped with maintenance-free battery.
- 7 - Tighten front axle pivot bolt to 35 ft.-lbs. maximum. Do not overtighten.

GENERAL RECOMMENDATIONS

The warranty on this tractor does not cover items that have been subjected to operator abuse or negligence. To receive full value from the warranty, operator must maintain tractor as instructed in this manual.

Some adjustments will need to be made periodically to properly maintain your tractor.

All adjustments in the Service and Adjustments section of this manual should be checked at least once each season.

- Once a year you should replace the spark plug, clean or replace air filter, and check blades and belts for wear. A new spark plug and clean air filter assure proper air-fuel mixture and help your engine run better and last longer.

BEFORE EACH USE

- Check engine oil level.
- Check brake operation.
- Check tire pressure.
- Check for loose fasteners.

LUBRICATION CHART

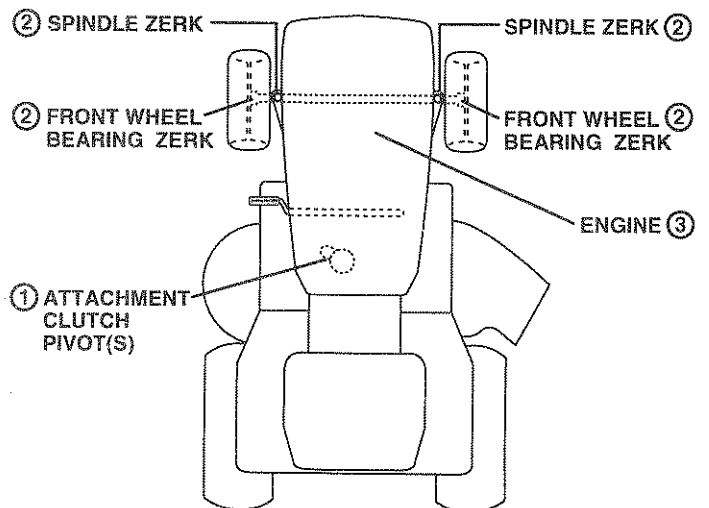

- ① SAE 30 OR 10W30 MOTOR OIL
- ② GENERAL PURPOSE GREASE
- ③ REFER TO CUSTOMER RESPONSIBILITIES "ENGINE" SECTION

IMPORTANT: DO NOT OIL OR GREASE THE PIVOT POINTS WHICH HAVE SPECIAL NYLON BEARINGS. VISCOUS LUBRICANTS WILL ATTRACT DUST AND DIRT THAT WILL SHORTEN THE LIFE OF THE SELF-LUBRICATING BEARINGS. IF YOU FEEL THEY MUST BE LUBRICATED, USE ONLY A DRY, POWDERED GRAPHITE TYPE LUBRICANT SPARINGLY.

CUSTOMER RESPONSIBILITIES

TRACTOR

Always observe safety rules when performing any maintenance.

BRAKE OPERATION

If tractor requires more than six (6) feet stopping distance at high speed in highest gear, then brake must be adjusted. (See "TO ADJUST BRAKE" in the Service and Adjustments section of this manual).

TIRES

- Maintain proper air pressure in all tires (See "PRODUCT SPECIFICATIONS" on page 3 of this manual).
- Keep tires free of gasoline, oil, or insect control chemicals which can harm rubber.
- Avoid stumps, stones, deep ruts, sharp objects and other hazards that may cause tire damage.

NOTE: To seal tire punctures and prevent flat tires due to slow leaks, tire sealant may be purchased from your local parts dealer. Tire sealant also prevents tire dry rot and corrosion.

BLADE CARE

For best results mower blades must be kept sharp. Replace bent or damaged blades.

BLADE REMOVAL (See Fig. 11)

- Raise mower to highest position to allow access to blades.
- Remove hex bolt, lock washer and flat washer securing blade.
- Install new or resharpened blade with trailing edge up towards deck as shown.
- Reassemble hex bolt, lock washer and flat washer in exact order as shown.
- Tighten bolt securely (30-35 Ft. Lbs. torque).

IMPORTANT: BLADE BOLT IS GRADE 8 HEAT TREATED.

NOTE: We do not recommend sharpening blade - but if you do, be sure the blade is balanced.

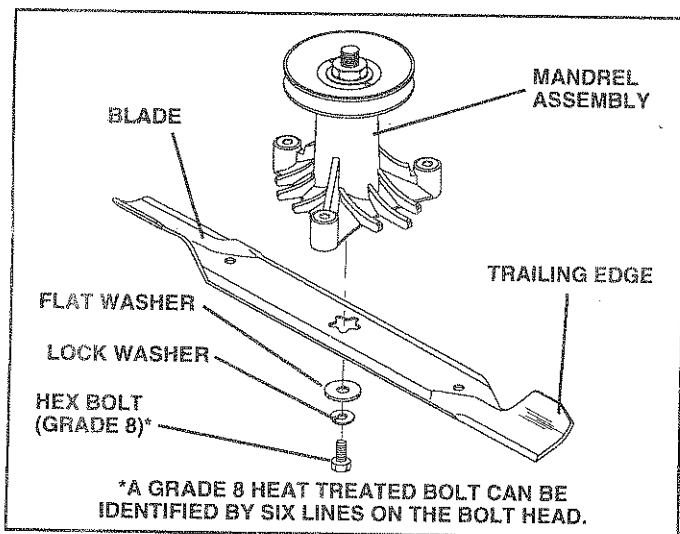

FIG. 11

TO SHARPEN BLADE (See Fig. 12)

Care should be taken to keep the blade balanced. An unbalanced blade will cause excessive vibration and eventual damage to mower and engine.

- The blade can be sharpened with a file or on a grinding wheel. Do not attempt to sharpen while on the mower.
- To check blade balance, you will need a 5/8" diameter steel bolt, pin, or a cone balancer. (When using a cone balancer, follow the instructions supplied with balancer).
- Slide blade on to an unthreaded portion of the steel bolt or pin and hold the bolt or pin parallel with the ground. If blade is balanced, it should remain in a horizontal position. If either end of the blade moves downward, sharpen the heavy end until the blade is balanced.

NOTE: Do not use a nail for balancing blade. The lobes of the center hole may appear to be centered, but are not.

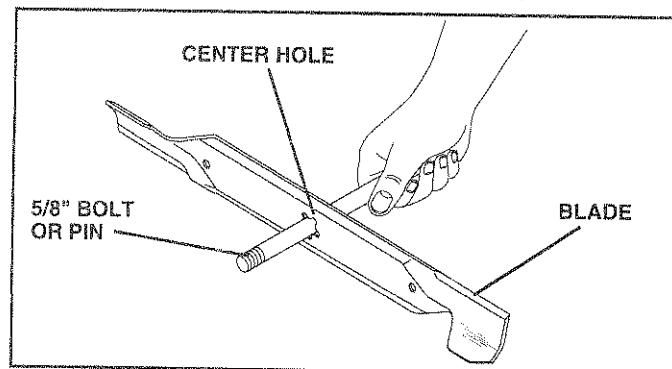

FIG. 12

BATTERY

Your tractor has a battery charging system which is sufficient for normal use. However, periodic charging of the battery with an automotive charger will extend its life.

- Keep battery and terminals clean.
- Keep battery bolts tight.
- Keep small vent holes open.
- Recharge at 6-10 amperes for 1 hour.

TO CLEAN BATTERY AND TERMINALS

Corrosion and dirt on the battery and terminals can cause the battery to "leak" power.

- Open battery box door.
- Disconnect BLACK battery cable first then RED battery cable and remove battery from tractor.
- Rinse the battery with plain water and dry.
- Clean terminals and battery cable ends with wire brush until bright.
- Coat terminals with grease or petroleum jelly.
- Reinstall battery (See "CONNECT BATTERY" in the Assembly section of this manual).

CUSTOMER RESPONSIBILITIES

V-BELTS

Check V-belts for deterioration and wear after 100 hours of operation and replace if necessary. The belts are not adjustable. Replace belts if they begin to slip from wear.

TRANSAXLE COOLING

The fan and cooling fins of transmission should be kept clean to assure proper cooling.

Do not attempt to clean fan or transmission while engine is running or while the transmission is hot.

- Inspect cooling fan to be sure fan blades are intact and clean.
- Inspect cooling fins for dirt, grass clippings and other materials. To prevent damage to seals, do not use compressed air or high pressure sprayer to clean cooling fins.

TRANSAXLE PUMP FLUID

The transaxle was sealed at the factory and fluid maintenance is not required for the life of the transaxle. Should the transaxle ever leak or require servicing, contact your nearest authorized service center/department.

ENGINE

LUBRICATION

Only use high quality detergent oil rated with API service classification SF, SG, or SH. Select the oil's SAE viscosity grade according to your expected operating temperature.

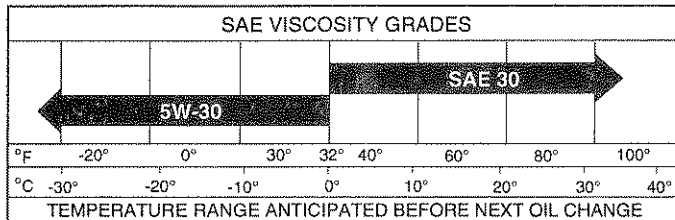

NOTE: Although multi-viscosity oils (5W30, 10W30 etc.) improve starting in cold weather, these multi-viscosity oils will result in increased oil consumption when used above 32°F. Check your engine oil level more frequently to avoid possible engine damage from running low on oil.

Change the oil after every 50 hours of operation or at least once a year if the tractor is not used for 50 hours in one year.

Check the crankcase oil level before starting the engine and after each eight (8) hours of operation. Tighten oil fill cap/dipstick securely each time you check the oil level.

TO CHANGE ENGINE OIL (See Fig. 13)

Determine temperature range expected before oil change. All oil must meet API service classification SF, SG or SH.

- Be sure tractor is on level surface.
- Oil will drain more freely when warm.
- Catch oil in a suitable container.
- Remove oil fill cap/dipstick. Be careful not to allow dirt to enter the engine when changing oil.
- Remove drain plug.
- After oil has drained completely, replace oil drain plug and tighten securely.
- Refill engine with oil through oil fill dipstick tube. Pour slowly. Do not overfill. For approximate capacity see "PRODUCT SPECIFICATIONS" on page 3 of this manual.
- Use gauge on oil fill cap/dipstick for checking level. Be sure dipstick cap is tightened securely for accurate reading. Keep oil at "FULL" line on dipstick.

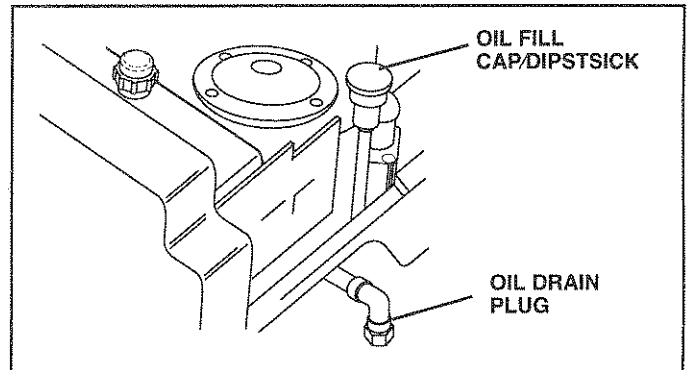

FIG. 13

CUSTOMER RESPONSIBILITIES

AIR FILTER (See Fig. 14)

Your engine will not run properly using a dirty air filter. Clean the foam pre-cleaner after every 25 hours of operation or every season. Service paper cartridge every 100 hours of operation or every season, whichever occurs first.

Service air cleaner more often under dusty conditions.

- Remove knob(s) and cover.

TO SERVICE PRE-CLEANER

- Slide foam pre-cleaner off cartridge.
- Wash it in liquid detergent and water.
- Squeeze it dry in a clean cloth.
- Saturate it in engine oil. Wrap it in clean, absorbent cloth and squeeze to remove excess oil.
- If very dirty or damaged, replace pre-cleaner.
- Reinstall pre-cleaner over cartridge.
- Reinstall cover and secure with knob(s).

TO SERVICE CARTRIDGE

- Remove cartridge nut.
- Carefully remove cartridge to prevent debris from entering carburetor. Clean base carefully to prevent debris from entering carburetor.
- Clean cartridge by tapping gently on flat surface. If very dirty or damaged, replace cartridge.
- Reinstall cartridge, nut, pre-cleaner, cover and secure with knob(s).

IMPORTANT: PETROLEUM SOLVENTS, SUCH AS KEROSENE, ARE NOT TO BE USED TO CLEAN THE CARTRIDGE. THEY MAY CAUSE DETERIORATION OF THE CARTRIDGE. DO NOT OIL CARTRIDGE. DO NOT USE PRESSURIZED AIR TO CLEAN OR DRY CARTRIDGE.

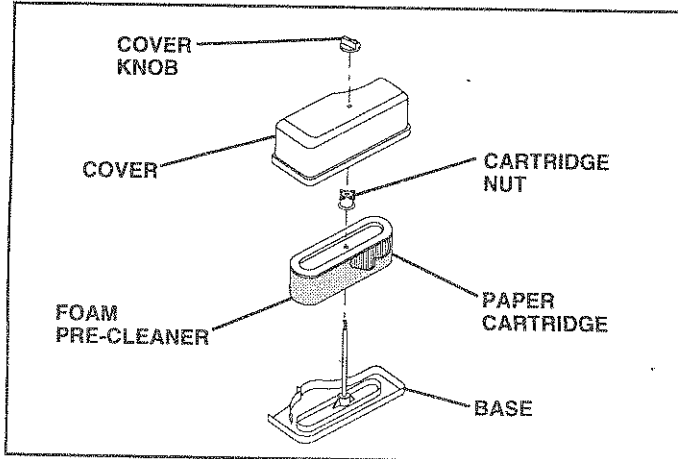

FIG. 14

CLEAN AIR SCREEN (See Fig. 14)

Air screen must be kept free of dirt and chaff to prevent engine damage from overheating. Clean with a wire brush or compressed air to remove dirt and stubborn dried gum fibers.

ENGINE COOLING FINS (See Fig. 15)

Remove any dust, dirt or oil from engine cooling fins to prevent engine damage from overheating.

- Remove screws from blower housing and lift housing and dipstick tube assembly off engine.
- Cover oil fill opening to prevent entry of dirt.
- Use compressed air or stiff bristle brush to thoroughly clean engine cooling fins.
- To reassemble, reverse above procedure.

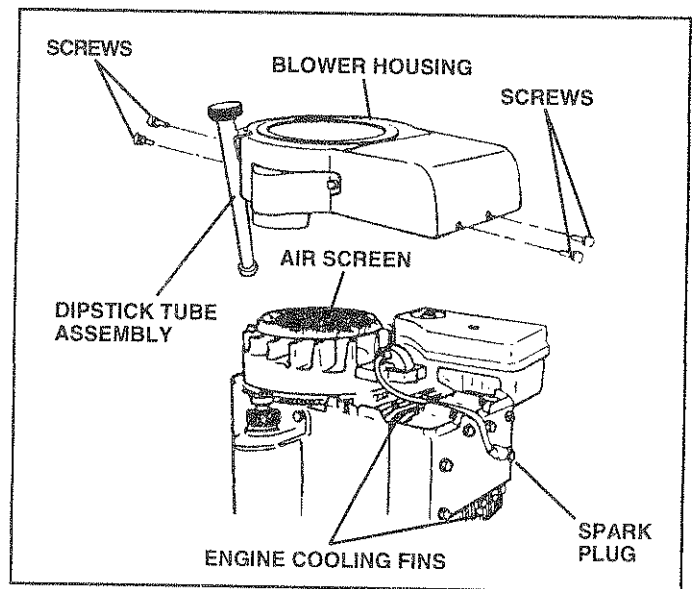

FIG. 15

CUSTOMER RESPONSIBILITIES

MUFFLER

Inspect and replace corroded muffler and spark arrester (if equipped) as it could create a fire hazard and/or damage.

SPARK PLUGS

Replace spark plugs at the beginning of each mowing season or after every 100 hours of operation, whichever occurs first. Spark plug type and gap setting are shown in "PRODUCT SPECIFICATIONS" on page 2 of this manual.

IN-LINE FUEL FILTER (See Fig. 16)

The fuel filter should be replaced once each season. If fuel filter becomes clogged, obstructing fuel flow to carburetor, replacement is required.

- With engine cool, remove filter and plug fuel line sections.
- Place new fuel filter in position in fuel line with arrow pointing towards carburetor.
- Be sure there are no fuel line leaks and clamps are properly positioned.
- Immediately wipe up any spilled gasoline.

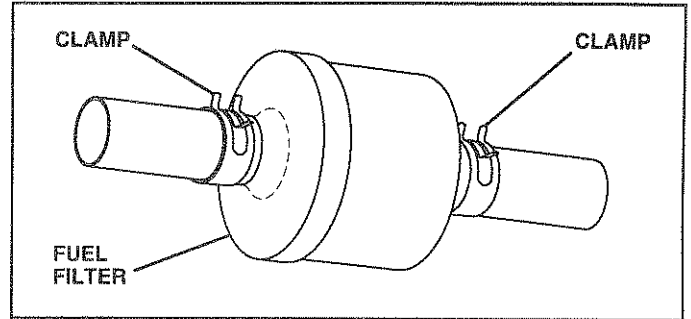

FIG. 16

CLEANING

- Clean engine, battery, seat, finish, etc. of all foreign matter.
- Keep finished surfaces and wheels free of all gasoline, oil, etc.
- Protect painted surfaces with automotive type wax.

We do not recommend using a garden hose to clean your tractor unless the electrical system, muffler, air filter and carburetor are covered to keep water out. Water in engine can result in a shortened engine life.

SERVICE AND ADJUSTMENTS



CAUTION: BEFORE PERFORMING ANY SERVICE OR ADJUSTMENTS:

- Depress clutch/brake pedal fully and set parking brake.
- Place motion control lever in neutral (N) position.
- Place attachment clutch in "DISENGAGED" position.
- Turn ignition key "OFF" and remove key.
- Make sure the blades and all moving parts have completely stopped.
- Disconnect spark plug wire from spark plug and place wire where it cannot come in contact with plug.

TRACTOR

TO REMOVE MOWER (See Fig. 17)

Mower will be easier to remove from the right side of tractor.

- Place attachment clutch in "DISENGAGED" position.
- Move attachment lift lever forward to lower mower to its lowest position.
- Roll belt off engine pulley.
- Disconnect clutch rod from clutch lever by removing retainer spring.
- Disconnect anti-sway bar from chassis bracket by removing retainer spring.
- Disconnect suspension arms from rear deck brackets by removing retainer springs.
- Disconnect front links from deck by removing retainer springs.
- Raise lift lever to raise suspension arms. Slide mower out from under tractor.

IMPORTANT: IF AN ATTACHMENT OTHER THAN THE MOWER IS TO BE MOUNTED TO THE TRACTOR, THE R.H. AND L.H. SUSPENSION ARMS MUST BE REMOVED FROM TRACTOR.

TO INSTALL MOWER (See Fig. 17)

- Raise attachment lift lever to its highest position.
- Slide mower under tractor with discharge guard to right side of tractor.
- Lower lift lever to its lowest position.
- Install mower in reverse order of removal instructions.

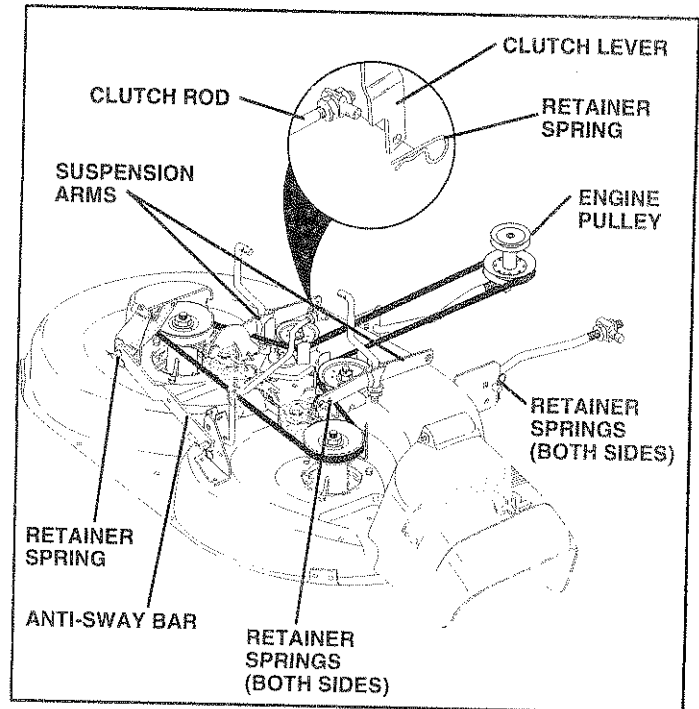

FIG. 17

SERVICE AND ADJUSTMENTS

TO LEVEL MOWER HOUSING

Adjust the mower while tractor is parked on level ground or driveway. Make sure tires are properly inflated (See "PRODUCT SPECIFICATIONS" on page 2 of this manual). If tires are over or underinflated, you will not properly adjust your mower.

SIDE-TO-SIDE ADJUSTMENT (See Figs. 18 and 19)

- Raise mower to its highest position.
- At the midpoint of both sides of mower, measure height from bottom edge of mower to ground. Distance "A" on both sides of mower should be the same or within 1/4" of each other.
- If adjustment is necessary, make adjustment on one side of mower only.
- To raise one side of mower, tighten lift link adjustment nut on that side.
- To lower one side of mower, loosen lift link adjustment nut on that side.

NOTE: Three full turns of adjustment nut will change mower height about 1/8".

- Recheck measurements after adjusting.

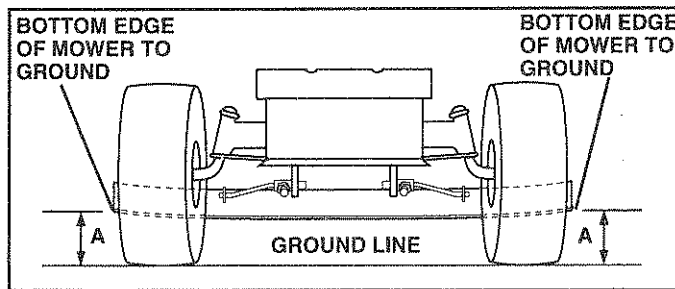

FIG. 18

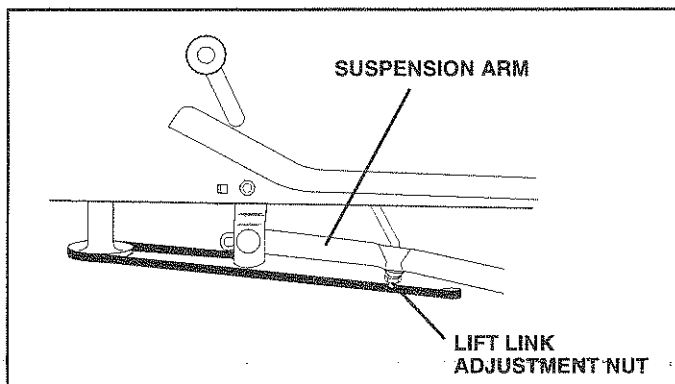

FIG. 19

FRONT-TO-BACK ADJUSTMENT (See Figs. 20 and 21)

IMPORTANT: DECK MUST BE LEVEL SIDE-TO-SIDE. IF THE FOLLOWING FRONT-TO-BACK ADJUSTMENT IS NECESSARY, BE SURE TO ADJUST BOTH FRONT LINKS EQUALLY SO MOWER WILL STAY LEVEL SIDE-TO-SIDE.

To obtain the best cutting results, the mower housing should be adjusted so that the front is approximately 1/8" to 1/2" lower than the rear when the mower is in its highest position.

Check adjustment on right side of tractor. Measure distance "D" directly in front and behind the mandrel at bottom edge of mower housing as shown.

- Before making any necessary adjustments, check that both front links are equal in length. Both links should be approximately 10-3/8".
- If links are not equal in length, adjust one link to same length as other link.
- To lower front of mower loosen nut "E" on both front links an equal number of turns.
- When distance "D" is 1/8" to 1/2" lower at front than rear, tighten nuts "F" against trunnion on both front links.
- To raise front of mower, loosen nut "F" from trunnion on both front links. Tighten nut "E" on both front links an equal number of turns.
- When distance "D" is 1/8" to 1/2" lower at front than rear, tighten nut "F" against trunnion on both front links.
- Recheck side-to-side adjustment.

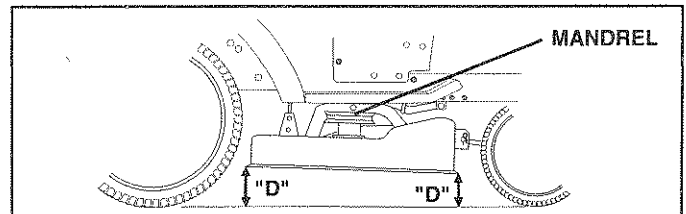

FIG. 20

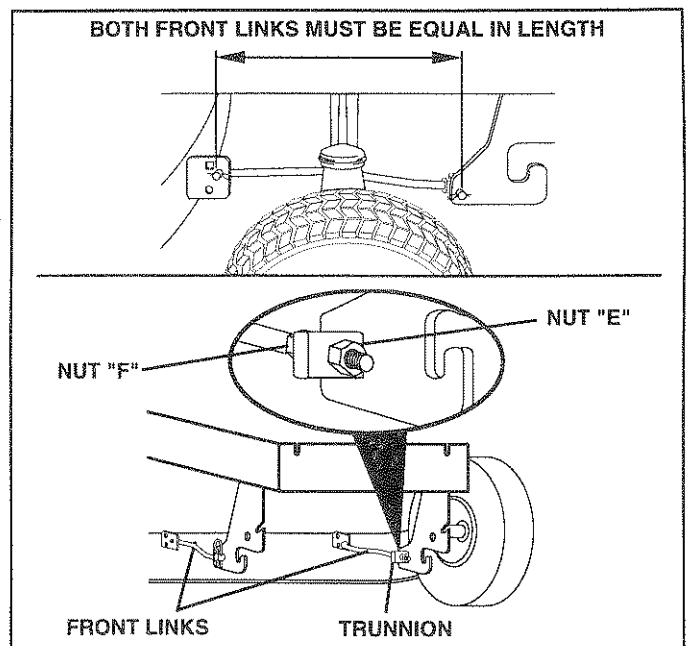

FIG. 21

SERVICE AND ADJUSTMENTS

TO REPLACE MOWER BLADE DRIVE BELT (See Fig. 22)

The mower blade drive belt may be replaced without tools. Park the tractor on level surface. Engage parking brake.

BELT REMOVAL -

- Remove mower from tractor (See "TO REMOVE MOWER" in this section of this manual).
- Work belt off both mandrel pulleys and idler pulleys.
- Pull belt away from mower.

BELT INSTALLATION -

- Install new belt in reverse order of removal.
- Make sure belt is in all pulley grooves and inside all belt guides.
- Install mower in reverse order of removal instructions.

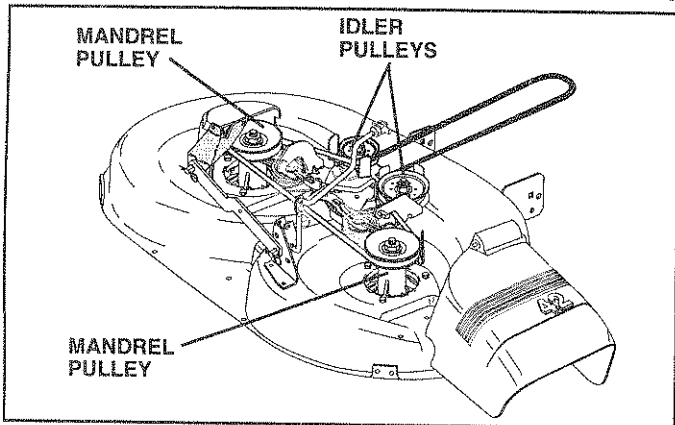

FIG. 22

TO ADJUST BRAKE (See Fig. 23)

Your tractor is equipped with an adjustable brake system which is mounted on the side of the transaxle.

If tractor requires more than six (6) feet stopping distance at high speed in highest gear, then brake must be adjusted.

- Depress clutch/brake pedal and engage parking brake.
- Measure distance between brake operating arm and nut "A" on brake rod.

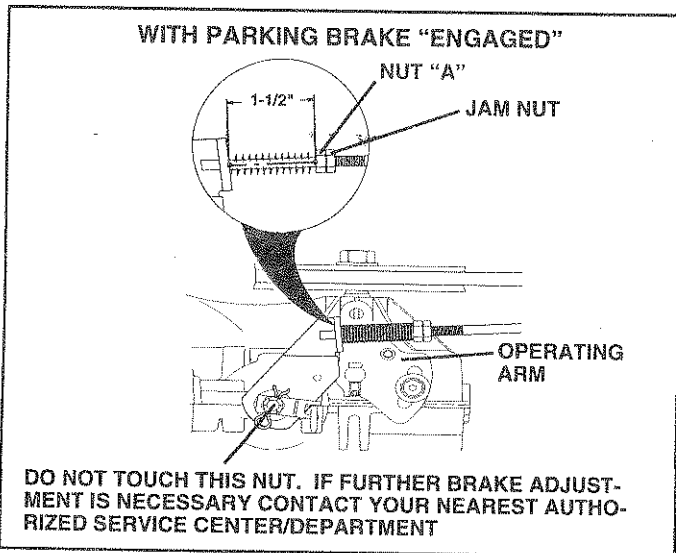

FIG. 23

- If distance is other than 1-1/2", loosen jam nut and turn nut "A" until distance becomes 1-1/2". Retighten jam nut against nut "A".
- Road test tractor for proper stopping distance as stated above. Readjust if necessary. If stopping distance is still greater than six (6) feet in highest gear, further maintenance is necessary. Contact your nearest authorized service center/department.

TO REPLACE MOTION DRIVE BELT (See Fig. 24)

Park the tractor on level surface. Engage parking brake. For assistance, there is a belt installation guide decal on bottom side of left footrest.

- Remove mower (See "TO REMOVE MOWER" in this section of this manual.)
- Remove upper belt keeper.
- Remove belt from stationary idler and clutching idler.
- Pull belt slack toward rear of tractor. Carefully remove belt upwards from transmission input pulley and over cooling fan blades.
- Pull belt toward front of tractor and remove downward from around engine pulley.
- Install new belt by reversing above procedure.

IMPORTANT: MAKE SURE UPPER BELT KEEPER IS POSITIONED PROPERLY BETWEEN LOCATOR TABS.

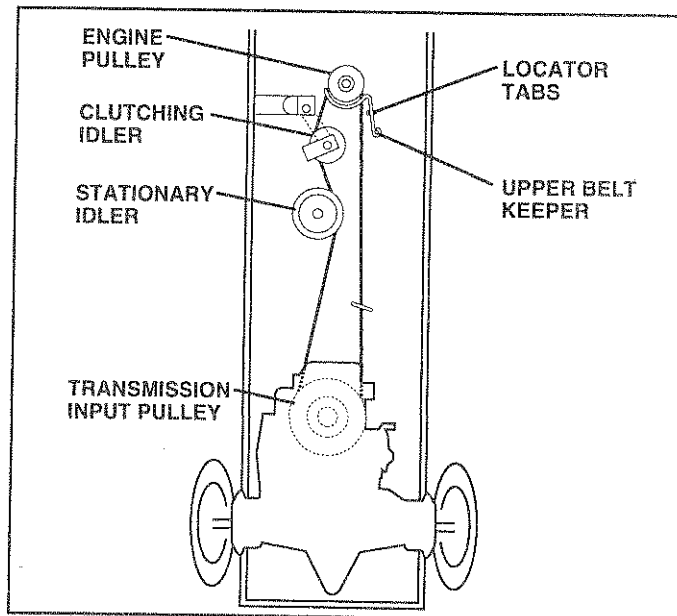

FIG. 24

SERVICE AND ADJUSTMENTS

TRANSMISSION REMOVAL/REPLACEMENT

Should your transmission require removal for service or replacement, it should be purged after reinstallation and before operating the tractor. See "PURGE TRANSMISSION" in the Operation section of this manual.

TO ADJUST STEERING WHEEL ALIGNMENT

If steering wheel crossbars are not horizontal (left to right) when wheels are positioned straight forward, remove steering wheel and reassemble per instructions in the Assembly section of this manual.

FRONT WHEEL TOE-IN/CAMBER

The front wheel toe-in and camber are not adjustable on your tractor. If damage has occurred to affect the front wheel toe-in or camber, contact your nearest authorized service center/department.

TO REMOVE WHEEL FOR REPAIRS (See Fig. 25)

- Block up axle securely.
- Remove axle cover, retaining ring and washers to allow wheel removal (rear wheel contains a square key - Do not lose).
- Repair tire and reassemble.
- On rear wheels only: align grooves in rear wheel hub and axle. Insert square key.
- Replace washers and snap retaining ring securely in axle groove.
- Replace axle cover.

NOTE: To seal tire punctures and prevent flat tires due to slow leaks, tire sealant may be purchased from your local parts dealer. Tire sealant also prevents tire dry rot and corrosion.

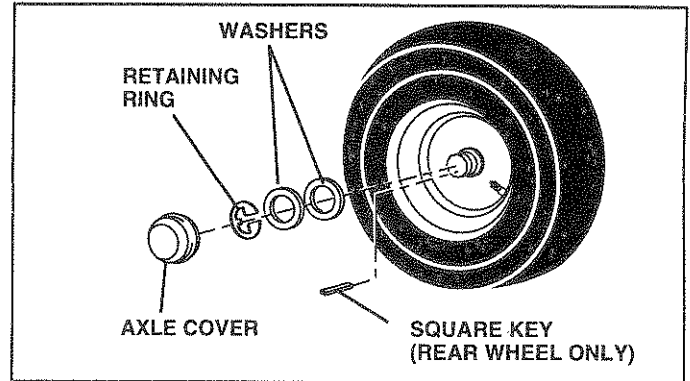

FIG. 25

SERVICE AND ADJUSTMENTS

TO START ENGINE WITH A WEAK BATTERY (See Fig. 26)



CAUTION: Lead-acid batteries generate explosive gases. Keep sparks, flame and smoking materials away from batteries. Always wear eye protection when around batteries.

If your battery is too weak to start the engine, it should be recharged. If "jumper cables" are used for emergency starting, follow this procedure:

IMPORTANT: YOUR TRACTOR IS EQUIPPED WITH A 12 VOLT NEGATIVE GROUND SYSTEM. THE OTHER VEHICLE MUST ALSO BE A 12 VOLT NEGATIVE GROUND SYSTEM. DO NOT USE YOUR TRACTOR BATTERY TO START OTHER VEHICLES.

TO ATTACH JUMPER CABLES -

- Connect each end of the RED cable to the POSITIVE (+) terminal of each battery, taking care not to short against chassis.
- Connect one end of the BLACK cable to the NEGATIVE (-) terminal of fully charged battery.
- Connect the other end of the BLACK cable to good CHASSIS GROUND, away from fuel tank and battery.

TO REMOVE CABLES, REVERSE ORDER -

- BLACK cable first from chassis and then from the fully charged battery.
- RED cable last from both batteries.

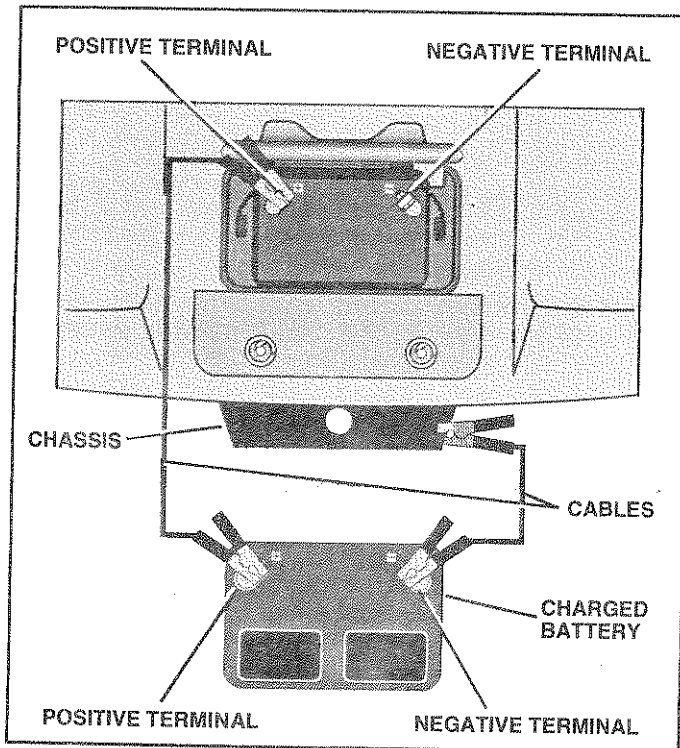

FIG. 26

TO REPLACE HEADLIGHT BULB

- Raise hood.
- Pull bulb holder out of the hole in the backside of the grill.
- Replace bulb in holder and push bulb holder securely back into the hole in the backside of the grill.
- Close hood.

INTERLOCKS AND RELAYS

Loose or damaged wiring may cause your tractor to run poorly, stop running, or prevent it from starting.

- Check wiring. See electrical wiring diagram in the Repair Parts section of this manual.

TO REPLACE FUSE

Replace with 30 amp automotive-type plug-in fuse. The fuse holder is located behind the dash.

TO REMOVE HOOD AND GRILL ASSEMBLY (See Fig. 27)

- Raise hood.
- Unsnap headlight wire connector.
- Stand in front of tractor. Grasp hood at sides, tilt toward engine and lift off of tractor.
- To replace, reverse above procedure.

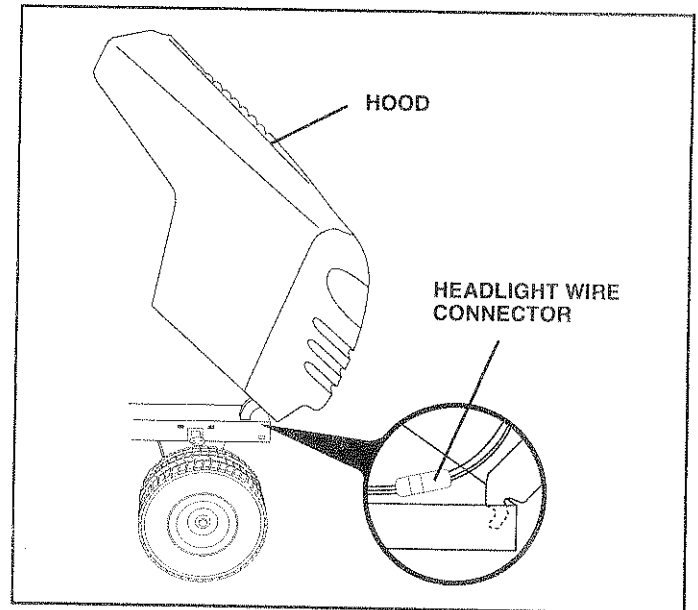

FIG. 27

SERVICE AND ADJUSTMENTS

ENGINE

TO ADJUST THROTTLE CONTROL CABLE (See Fig. 28)

The throttle control has been preset at the factory and adjustment should not be necessary. Check adjustment as described below before loosening cable. If adjustment is necessary, proceed as follows:

- With engine not running, move throttle control lever from slow to choke position. Slowly move lever from choke to fast position.
- Check that holes "A" in governor control lever and hole in governor plate line-up. If holes "A" are not aligned, loosen clamp screw and move throttle cable until holes are aligned. Tighten clamp screw securely.

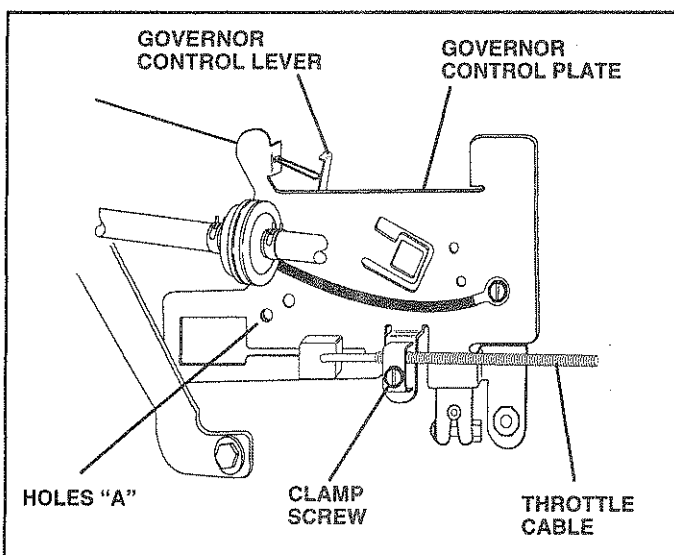

FIG. 28

TO ADJUST CARBURETOR (See Fig. 29)

The carburetor has been preset at the factory and adjustment should not be necessary. However, minor adjustment may be required to compensate for differences in fuel, temperature, altitude or load. If the carburetor does need adjustment, proceed as follows:

In general, turning idle mixture valve **in** (clockwise) decreases the supply of fuel to the engine giving a leaner fuel/air mixture. Turning the idle mixture valve **out** (counterclockwise) increases the supply of fuel to the engine giving a richer fuel/air mixture.

IMPORTANT: DAMAGE TO THE NEEDLE VALVE AND THE SEAT IN CARBURETOR MAY RESULT IF SCREW IS TURNED IN TOO TIGHT.

PRELIMINARY SETTING -

- Air cleaner assembly must be assembled to the carburetor when making carburetor adjustments.
- Be sure the throttle control cable is adjusted properly (see above).
- With engine off turn idle mixture valve **in** (clockwise) closing it finger tight and then turn **out** (counterclockwise) 1 full turn.

FINAL SETTING -

- Start engine and allow to warm for five minutes. Make final adjustments with engine running and shift/motion control lever in neutral (N) position.
- Move throttle control lever to slow position. With finger, rotate and hold throttle lever against idle speed screw. Turn idle speed screw to attain 1750 RPM.
- While still holding throttle lever against idle speed screw, turn idle mixture valve **in** (clockwise) until engine begins to die and then turn **out** (counterclockwise) until engine runs rough. Turn valve to a point midway between those two positions. Release throttle lever.

ACCELERATION TEST -

- Move throttle control lever from slow to fast position. If engine hesitates or dies, turn idle mixture valve **out** (counterclockwise) 1/8 turn. Repeat test and continue to adjust, if necessary, until engine accelerates smoothly.

High speed stop is factory adjusted. Do not adjust - damage may result.

IMPORTANT: NEVER TAMPER WITH THE ENGINE GOVERNOR, WHICH IS FACTORY SET FOR PROPER ENGINE SPEED. OVERSPEEDING THE ENGINE ABOVE THE FACTORY HIGH SPEED SETTING CAN BE DANGEROUS. IF YOU THINK THE ENGINE-GOVERNED HIGH SPEED NEEDS ADJUSTING, CONTACT YOUR NEAREST AUTHORIZED SERVICE CENTER/DEPARTMENT, WHICH HAS PROPER EQUIPMENT AND EXPERIENCE TO MAKE ANY NECESSARY ADJUSTMENTS.

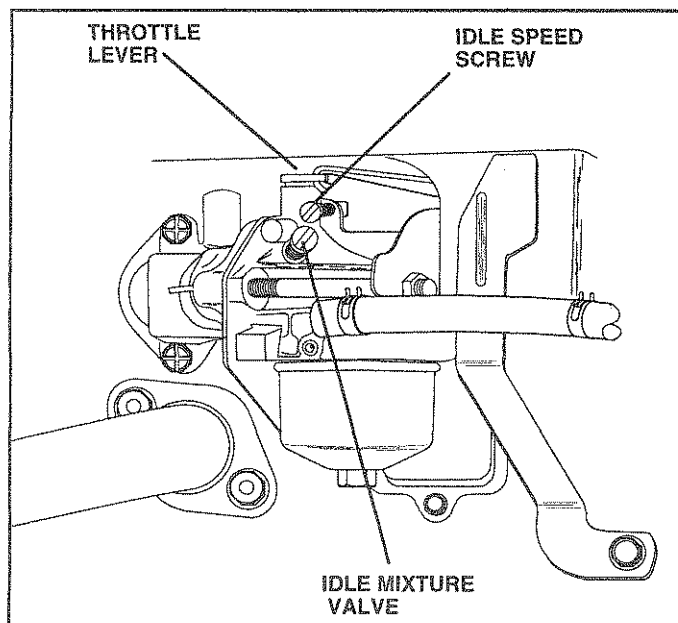

FIG. 29

STORAGE

Immediately prepare your tractor for storage at the end of the season or if the tractor will not be used for 30 days or more.



CAUTION: Never store the tractor with gasoline in the tank inside a building where fumes may reach an open flame or spark. Allow the engine to cool before storing in any enclosure.

TRACTOR

Remove mower from tractor for winter storage. When mower is to be stored for a period of time, clean it thoroughly, remove all dirt, grease, leaves, etc. Store in a clean, dry area.

- Clean entire tractor (See "CLEANING" in the Customer Responsibilities section of this manual).
- Inspect and replace belts, if necessary (See belt replacement instructions in the Service and Adjustments section of this manual).
- Lubricate as shown in the Customer Responsibilities section of this manual.
- Be sure that all nuts, bolts and screws are securely fastened. Inspect moving parts for damage, breakage and wear. Replace if necessary.
- Touch up all rusted or chipped paint surfaces; sand lightly before painting.

BATTERY

- Fully charge the battery for storage.
- After a period of time in storage, battery may require recharging.
- To help prevent corrosion and power leakage during long periods of storage, battery cables should be disconnected and battery cleaned thoroughly (see "TO CLEAN BATTERY AND TERMINALS" in the Customer Responsibilities section of this manual).
- After cleaning, leave cables disconnected and place cables where they cannot come in contact with battery terminals.
- Be sure battery drain tube is securely attached.
- If battery is removed from tractor for storage, do not store battery directly on concrete or damp surfaces.

ENGINE

FUEL SYSTEM

IMPORTANT: IT IS IMPORTANT TO PREVENT GUM DEPOSITS FROM FORMING IN ESSENTIAL FUEL SYSTEM PARTS SUCH AS CARBURETOR, FUEL FILTER, FUEL HOSE, OR TANK DURING STORAGE. ALSO EXPERIENCE INDICATES THAT ALCOHOL BLENDED FUELS (CALLED GASOHOL OR USING ETHANOL OR METHANOL) CAN ATTRACT MOISTURE WHICH LEADS TO SEPARATION AND FORMATION OF ACIDS DURING STORAGE. ACIDIC GAS CAN DAMAGE THE FUEL SYSTEM OF AN ENGINE WHILE IN STORAGE.

- Drain the fuel tank.
- Start the engine and let it run until the fuel lines and carburetor are empty.
- Never use engine or carburetor cleaner products in the fuel tank or permanent damage may occur.
- Use fresh fuel next season.

NOTE: Fuel stabilizer is an acceptable alternative in minimizing the formation of fuel gum deposits during storage. Add stabilizer to gasoline in fuel tank or storage container. Always follow the mix ratio found on stabilizer container. Run engine at least 10 minutes after adding stabilizer to allow the stabilizer to reach the carburetor. Do not drain the gas tank and carburetor if using fuel stabilizer.

ENGINE OIL

Drain oil (with engine warm) and replace with clean engine oil. (See "ENGINE" in the Customer Responsibilities section of this manual).

CYLINDERS

- Remove spark plug(s).
- Pour one ounce of oil through spark plug hole(s) into cylinder(s).
- Turn ignition key to "START" position for a few seconds to distribute oil.
- Replace with new spark plug(s).

OTHER

- Do not store gasoline from one season to another.
- Replace your gasoline can if your can starts to rust. Rust and/or dirt in your gasoline will cause problems.
- If possible, store your tractor indoors and cover it to give protection from dust and dirt.
- Cover your tractor with a suitable protective cover that does not retain moisture. Do not use plastic. Plastic cannot breathe which allows condensation to form and will cause your tractor to rust.

IMPORTANT: NEVER COVER TRACTOR WHILE ENGINE AND EXHAUST AREAS ARE STILL WARM.

TROUBLESHOOTING POINTS

PROBLEM	CAUSE	CORRECTION
Will not start	<ol style="list-style-type: none"> 1. Out of fuel. 2. Engine not "CHOKED" properly. 3. Engine flooded. 4. Bad spark plug. 5. Dirty air filter. 6. Dirty fuel filter. 7. Water in fuel. 8. Loose or damaged wiring. 9. Carburetor out of adjustment. 10. Engine valves out of adjustment. 	<ol style="list-style-type: none"> 1. Fill fuel tank. 2. See "TO START ENGINE" in Operation section. 3. Wait several minutes before attempting to start. 4. Replace spark plug. 5. Clean/replace air filter. 6. Replace fuel filter. 7. Drain fuel tank and carburetor, refill tank with fresh gasoline and replace fuel filter. 8. Check all wiring. 9. See "To Adjust Carburetor" in Service Adjustments section. 10. Contact an authorized service center/department.
Hard to start	<ol style="list-style-type: none"> 1. Dirty air filter. 2. Bad spark plug. 3. Weak or dead battery. 4. Dirty fuel filter. 5. Stale or dirty fuel. 6. Loose or damaged wiring. 7. Carburetor out of adjustment. 8. Engine valves out of adjustment. 	<ol style="list-style-type: none"> 1. Clean/replace air filter. 2. Replace spark plug. 3. Recharge or replace battery. 4. Replace fuel filter. 5. Drain fuel tank and refill with fresh gasoline. 6. Check all wiring. 7. See "To Adjust Carburetor" in Service Adjustments section. 8. Contact an authorized service center/department.
Engine will not turn over	<ol style="list-style-type: none"> 1. Clutch/brake pedal not depressed. 2. Attachment clutch is engaged. 3. Weak or dead battery. 4. Blown fuse. 5. Corroded battery terminals. 6. Loose or damaged wiring. 7. Faulty ignition switch. 8. Faulty solenoid or starter. 9. Faulty operator presence switch(es). 	<ol style="list-style-type: none"> 1. Depress clutch/brake pedal. 2. Disengage attachment clutch. 3. Recharge or replace battery. 4. Replace fuse. 5. Clean battery terminals. 6. Check all wiring. 7. Check/replace ignition switch. 8. Check/replace solenoid or starter. 9. Contact an authorized service center/department.
Engine clicks but will not start	<ol style="list-style-type: none"> 1. Weak or dead battery. 2. Corroded battery terminals. 3. Loose or damaged wiring. 4. Faulty solenoid or starter. 	<ol style="list-style-type: none"> 1. Recharge or replace battery. 2. Clean battery terminals. 3. Check all wiring. 4. Check/replace solenoid or starter.
Loss of power	<ol style="list-style-type: none"> 1. Cutting too much grass/too fast. 2. Throttle in "CHOKED" position. 3. Build-up of grass, leaves and trash under mower. 4. Dirty air filter. 5. Low oil level/dirty oil. 6. Faulty spark plug. 7. Dirty fuel filter. 8. Stale or dirty fuel. 9. Water in fuel. 10. Spark plug wire loose. 11. Dirty engine air screen/fins. 12. Dirty/clogged muffler. 13. Loose or damaged wiring. 14. Carburetor out of adjustment. 15. Engine valves out of adjustment. 	<ol style="list-style-type: none"> 1. Set in "Higher Cut" position/reduce speed. 2. Adjust throttle control. 3. Clean underside of mower housing. 4. Clean/replace air filter. 5. Check oil level/change oil. 6. Clean and regap or change spark plug. 7. Replace fuel filter. 8. Drain fuel tank and refill with fresh gasoline. 9. Drain fuel tank and carburetor, refill tank with fresh gasoline and replace fuel filter. 10. Connect and tighten spark plug wire. 11. Clean engine air screen/fins. 12. Clean/replace muffler. 13. Check all wiring. 14. See "To Adjust Carburetor" in Service Adjustments section. 15. Contact an authorized service center/department.
Excessive vibration	<ol style="list-style-type: none"> 1. Worn, bent or loose blade. 2. Bent blade mandrel. 3. Loose/damaged part(s). 	<ol style="list-style-type: none"> 1. Replace blade. Tighten blade bolt. 2. Replace blade mandrel. 3. Tighten loose part(s). Replace damaged parts.

TROUBLESHOOTING POINTS

PROBLEM	CAUSE	CORRECTION
Engine continues to run when operator leaves seat with attachment clutch engaged	<ol style="list-style-type: none"> 1. Faulty operator-safety presence control system. 	<ol style="list-style-type: none"> 1. Check wiring, switches and connections. If not corrected, contact an authorized service center/department.
Poor cut - uneven	<ol style="list-style-type: none"> 1. Worn, bent or loose blade. 2. Mower deck not level. 3. Buildup of grass, leaves, and trash under mower. 4. Bent blade mandrel. 5. Clogged mower deck vent holes from buildup of grass, leaves, and trash around mandrels. 	<ol style="list-style-type: none"> 1. Replace blade. Tighten blade bolt. 2. Level mower deck. 3. Clean underside of mower housing. 4. Replace blade mandrel. 5. Clean around mandrels to open vent holes.
Mower blades will not rotate	<ol style="list-style-type: none"> 1. Obstruction in clutch mechanism. 2. Worn/damaged mower drive belt. 3. Frozen idler pulley. 4. Frozen blade mandrel. 	<ol style="list-style-type: none"> 1. Remove obstruction. 2. Replace mower drive belt. 3. Replace idler pulley. 4. Replace blade mandrel.
Poor grass discharge	<ol style="list-style-type: none"> 1. Engine speed too slow. 2. Travel speed too fast. 3. Wet grass. 4. Mower deck not level. 5. Low/uneven tire air pressure. 6. Worn, bent or loose blade. 7. Buildup of grass, leaves and trash under mower. 8. Mower drive belt worn. 9. Blades improperly installed. 10. Improper blades used. 11. Clogged mower deck vent holes from buildup of grass, leaves, and trash around mandrels. 	<ol style="list-style-type: none"> 1. Place throttle control in "FAST" position. 2. Shift to slower speed. 3. Allow grass to dry before mowing. 4. Level mower deck. 5. Check tires for proper air pressure. 6. Replace/sharpen blade. Tighten blade bolt. 7. Clean underside of mower housing. 8. Replace mower drive belt. 9. Reinstall blades sharp edge down. 10. Replace with blades listed in this manual. 11. Clean around mandrels to open vent holes.
Headlight(s) not working (if so equipped)	<ol style="list-style-type: none"> 1. Switch is "OFF". 2. Bulb(s) burned out. 3. Faulty light switch. 4. Loose or damaged wiring. 5. Blown fuse. 	<ol style="list-style-type: none"> 1. Turn switch "ON". 2. Replace bulb(s). 3. Check/replace light switch. 4. Check wiring and connections. 5. Replace fuse.
Battery will not charge	<ol style="list-style-type: none"> 1. Bad battery cell(s). 2. Poor cable connections. 3. Faulty regulator (if so equipped). 4. Faulty alternator. 	<ol style="list-style-type: none"> 1. Replace battery. 2. Check/clean all connections. 3. Replace regulator. 4. Replace alternator.
Loss of drive	<ol style="list-style-type: none"> 1. Freewheel control in "disengaged" position. 2. Motion drive belt worn, damaged, or broken. 3. Air trapped in transmission during shipment or servicing. 	<ol style="list-style-type: none"> 1. Place freewheel control in "engaged" position. 2. Replace motion drive belt. 3. Purge transmission.
Engine "backfires" when turning engine "OFF"	<ol style="list-style-type: none"> 1. Engine throttle control not set at "SLOW" position for 30 seconds before stopping engine. 	<ol style="list-style-type: none"> 1. Move throttle control to "SLOW" position and allow to idle for 30 seconds before stopping engine.

TRACTOR -- MODEL NUMBER HD145H42D

SCHEMATIC

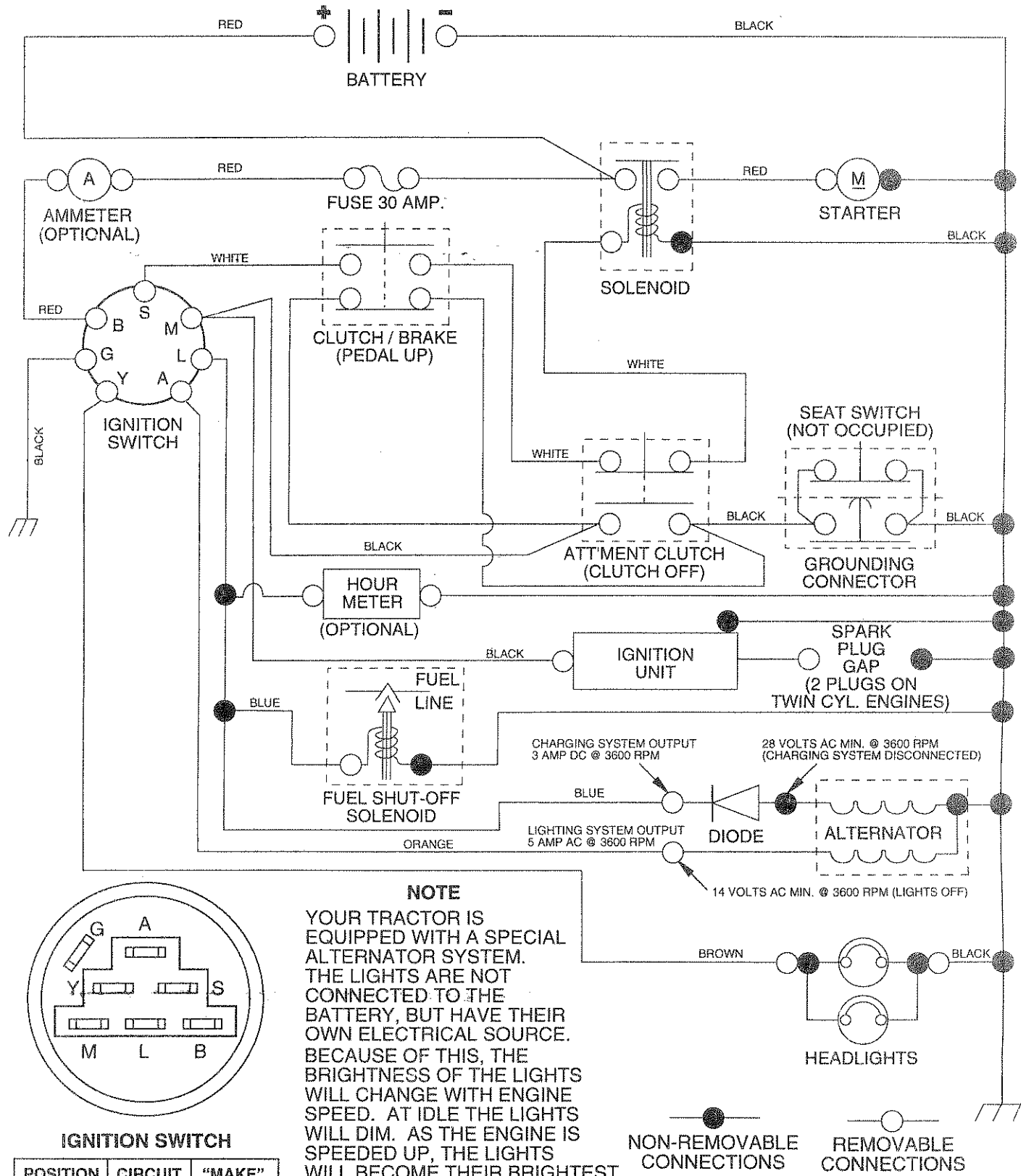

REPAIR PARTS

TRACTOR -- MODEL NUMBER HD145H42D

ELECTRICAL

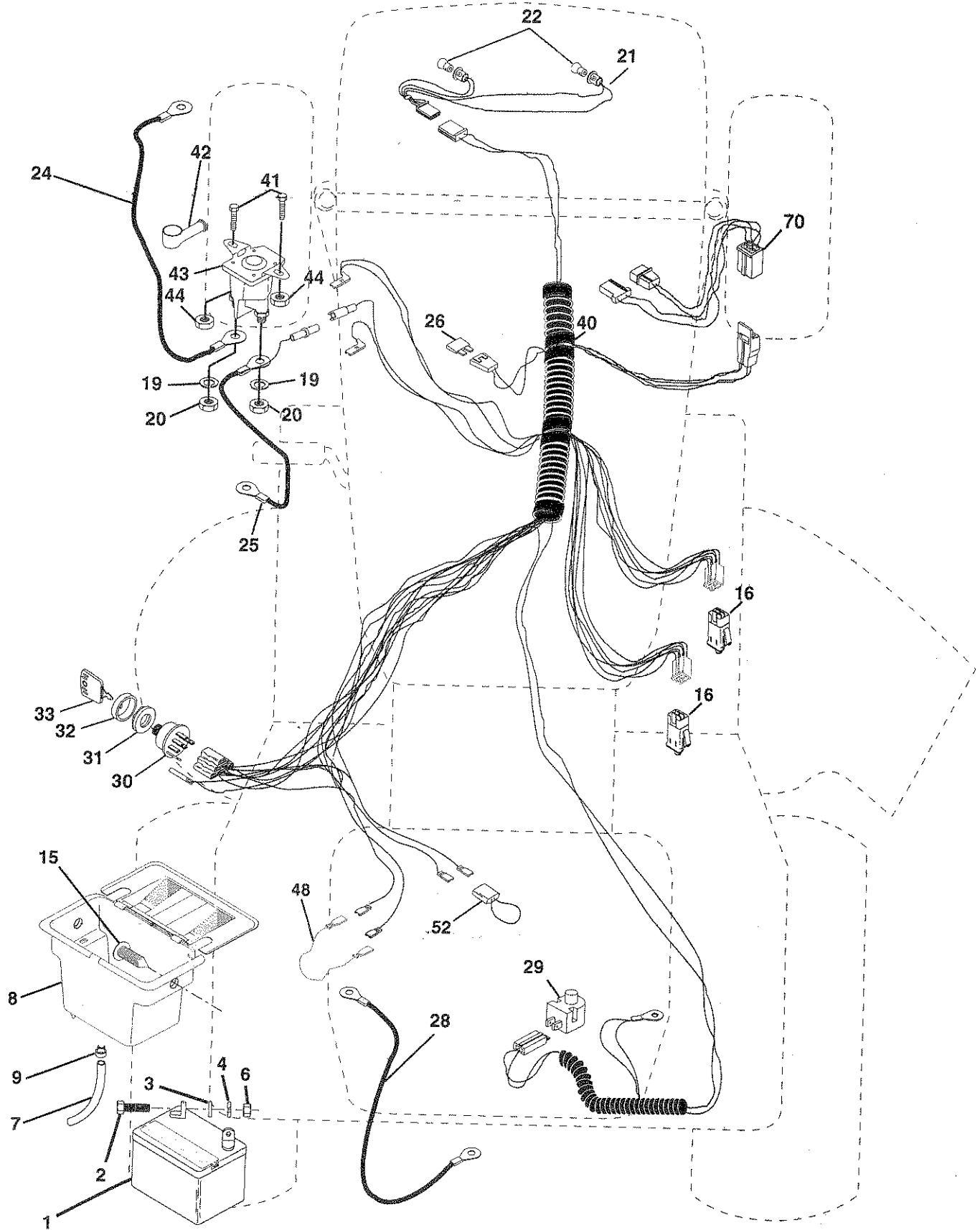

REPAIR PARTS

TRACTOR - - MODEL NUMBER HD145H42D

ELECTRICAL

KEY PART NO.	NO.	DESCRIPTION
1	144925	Battery 12 Volt 25 Amp
2	74760412	Bolt Hex Hd 1/4-20unc X 3/4
3	19091016	Washer 9/32 X 5/8 X 16 Ga
4	10040400	Washer Lock Hvy Helical 1/4
6	73220400	Nut Fin Hex 1/4-20 Unc
7	109238X	Tube Plastic 12"
8	156417	Case Battery Mech Hinge
9	109596X	Clamp Hose Olive
15	147688	Fastener Snap-In
16	153664	Switch Interlock Push-In
19	10090400	Washer Lock 1/4
20	73350400	Nut Jam Hex 1/4-20 Unc
21	136850	Harness Socket Light
22	4152J	Bulb, Light # 1156
24	4799J	Cable Starter 6ga 11" Red
25	146147	Cable Battery 6 Ga Red w/16 wire
26	108824X	Fuse 30 Amp Auto Green
28	4207J	Cable Ground 6ga 12"black
29	121305X	Switch Plunger Nc Gray
30	140301	Switch Ign 4 Pos W/L P/L
31	124211X	Nut Ignition
32	141226	Cover Sw Key
33	122147X	Key Ign Molded Generic
40	156442	Harness Ign
41	71110408	Bolt Fin Hex 1/4-20uncx 1/2
42	131563	Cover Terminal Red
43	145673	Solenoid
44	73640400	Nut Keps Blk Fin Hex 1/4-20 Unc x 1/2
48	140844	Adapter Ammeter Rectangular
52	141940	Protection Loop
70	140422	Harness Eng B&S 14 OHV Dual

NOTE: All component dimensions given in U.S. inches
1 inch = 25.4 mm

REPAIR PARTS

TRACTOR -- MODEL NUMBER HD145H42D

CHASSIS AND ENCLOSURES

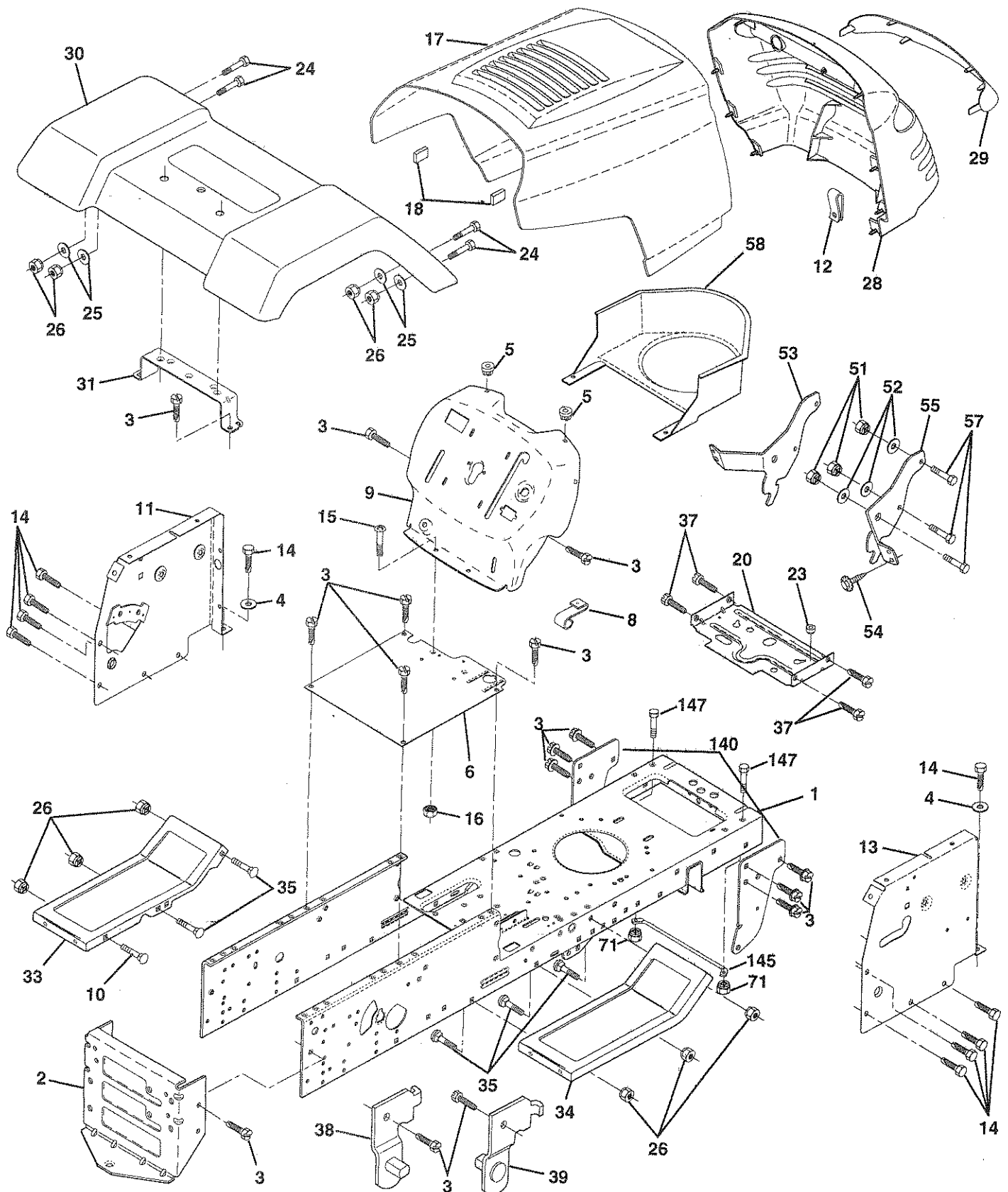

REPAIR PARTS

TRACTOR - - MODEL NUMBER HD145H42D

CHASSIS AND ENCLOSURES

KEY NO.	PART NO.	DESCRIPTION
1	159530	Chassis Wldmt.
2	140356	Drawbar Stretch 94
3	17490612	Screw Thdrol. 3/8-16 x 3/4 Ty-Tt
4	19131216	Washer 13/32 x 3/4 x 16 Ga.
5	155272	Bumper Hood/Dash
6	155923	Saddle Fender Shift Flat
8	155138	Clip Retainer Slide-On
9	147627X011	Dash Private Label
10	72140608	Bolt RdHd Sqnk. 3/8-16 Unc x 1
11	155927	Panel Asm. Dash Lh
12	145660	Clip Tinnerman Grille P/L
13	155934X010	Panel Dash Rh
14	17490608	Screw Thdrol. 3/8-16 x 1/2 Ty-Tt
15	74180512	Screw Mach Trhd 5/16-18 Unc x 3/4
16	73510500	Nut Keps 5/16-18 Unc
17	139394X428	Hood Pnt Steel Private Label
18	126938X	Bumper Hood
20	156437	Plate Mtg Battery/Fuel Tank
23	124028X	Bushing Snap Nyl. Blk Fuel Line
24	74780616	Bolt Fin Hex 3/8-16 Unc x 1 Gr. 5
25	19131312	Washer 13/32 x 13/16 x 12 Ga.
26	73800600	Nut Lock Hex w/Insert 3/8-16 UNC
28	157373	Grill Private Lable Blk
29	140273	Lens Grille Private label
30	140001X428	Fender Asm LT w/Shift MS-428
31	136619	Bracket Fender
33	105476X428	Footrest Pnt. Lh Ms-428
34	105475X428	Footrest Pnt. Rh Ms-428
35	72110606	Bolt RdHd Sht. Sqnk. 3/8-16 x 3/4
37	17490508	Screw Thdrol. 5/16-18 x 1/2 Tyt
38	139886	Bracket Asm. Pvt. Lh Mwr. Rear
39	139887	Bracket Asm. Pvt. Rh Mwr. Rear
51	73800400	Nut Lock Hex W/Ins. 1/4-20
52	19091416	Washer 9/32 x 7/8 x 16 Ga.
53	144697	Bracket Grille LH
54	17030814	Screw Lock Spider #8 x 7/8
55	144696	Bracket, Grille RH
57	74780412	Bolt Fin Hex 1/4-20 x .75
58	150127	Air Duct Private Label
71	73680400	Nut Crownlock 1/4-20 Unc
140	158418	Bracket Suspension Front
145	156524	Rod Pivot Chassis/Hood
147	74760412	Bolt Hex Hd 1/4-20 Unc x 3/4
--	5479J	Plug Btn Blk

NOTE: All component dimensions given in U.S. inches
1 inch = 25.4 mm

REPAIR PARTS

TRACTOR - - MODEL NUMBER HD145H42D

DRIVE

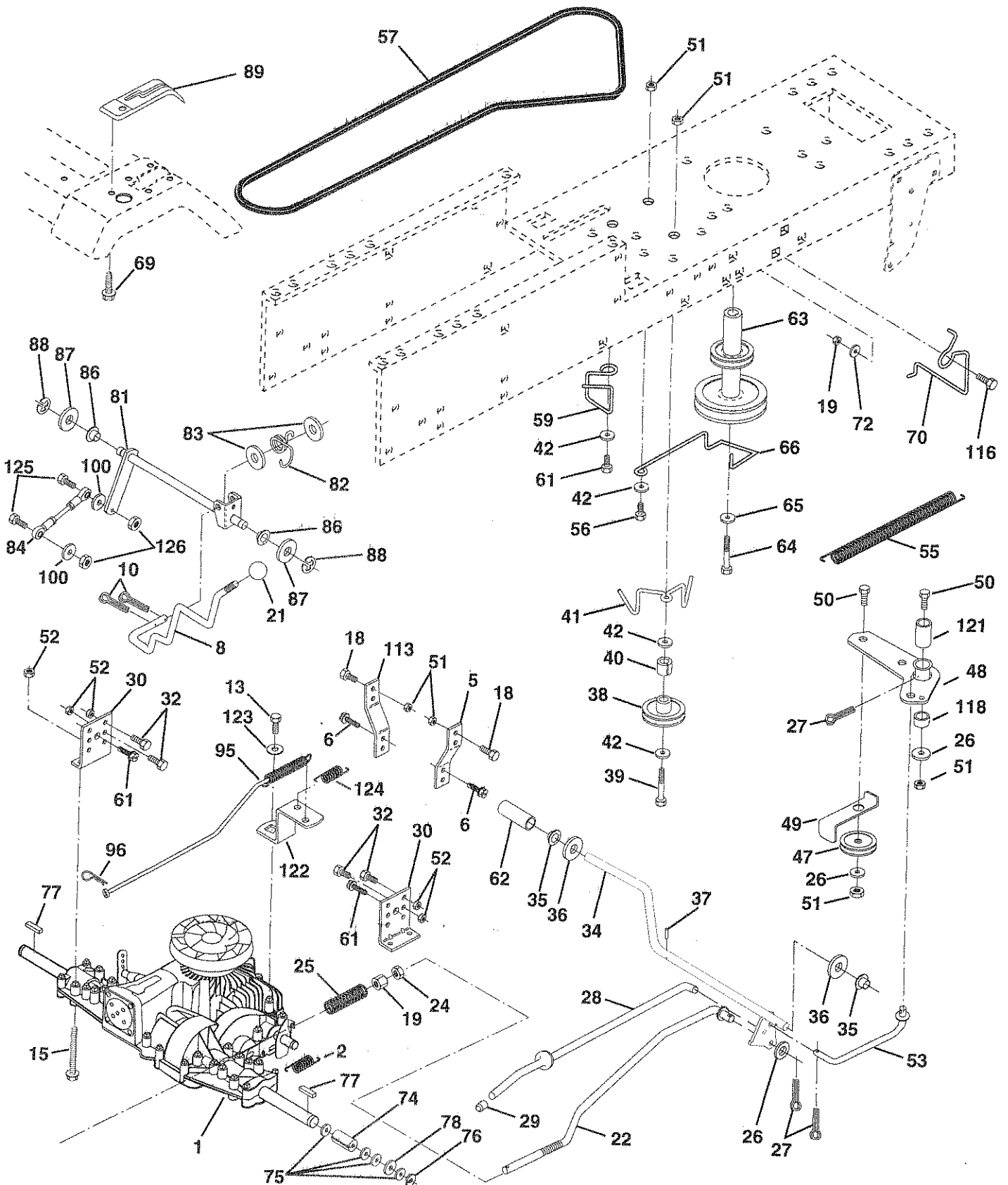

REPAIR PARTS

TRACTOR - - MODEL NUMBER HD145H42D

DRIVE

KEY NO.	PART NO.	DESCRIPTION	KEY NO.	PART NO.	DESCRIPTION
1	- - - - -	Transaxle (See Breakdown) Peerless Model 205-027B	56	74760620	Bolt Hex 3/8-16 x 1-1/4
2	146682	Spring, Return Brake	57	156971	V-Belt, Ground Drive
5	121520X	Strap Torque	59	140312	Keeper, Center Span
6	17490512	Screw Thdrol 5/16-18 x 3/4	61	17490612	Screw Thdrol. 3/8-16 x 3/4 Ty. TT
8	141003	Rod Shift Hydro LT	62	8883R	Cover, Pedal
10	76020416	Pin Cotter 1/8 x 1 CAD	63	140186	Pulley, Engine
13	74550412	Bolt 1/4-28 Unf Gr. 8 W/Patch	64	71170764	Bolt Hex 7/16-20 X 4 Gr. 5
15	74490544	Bolt Hex Fighd 5/16-18 Gr. 5	65	10040700	Washer
18	74780616	Bolt Fin Hex 3/8-16 Unc x 1 Gr. 5	66	154778	Keeper Belt Engine
19	73800600	Nut Lock Hex W/Wsh 3/8-16 Unc	69	142432	Screw
21	106933X	Knob, Round 1/2-13	70	134683	Keeper Belt Engine
22	130804	Rod, Brake	72	19132012	Washer 13/32 x 1-1/4 x 12 Gauge
24	73350600	Nut, Hex Jam 3/8-16 Unc	74	156972	Spacer, Axle PVST
25	106888X	Spring, Brake Rod	75	121749X	Washer 25/32 x 1-1/4 x 16 Gauge
26	19131316	Washer	76	12000001	E-Ring
27	76020412	Pin Cotter 1/8 x 3/4 CAD.	77	123583X	Key, Square
28	145204	Rod, Parking Brake	78	121748X	Washer 25/32 x 1-5/8 x 16 Gauge
29	71673	Cap, Parking Brake	81	158461	Shaft Asm. Cross Hydro 18" Tires
30	130807	Bracket, Transaxle	82	123782X	Spring Torsion T/A
32	74760512	Bolt Hex Hd 5/16-18 Unc x 3/4	83	19171216	Washer 17/32 x 3/4 x 16 Ga.
34	155071	Shaft, Foot Pedal	84	158286	Rod, Tie PVST 18"
35	120183X	Bearing, Nylon	86	71208	Bushing Rod Strig. 629/632 ID
36	19211616	Washer	87	19212016	Washer 21/32 x 1-1/4 x 16 Ga.
37	1572H	Pin, Roll	88	12000008	Ring Klip #5304-62
38	123674X	Pulley, Idler, Flat	89	151147	Console, Shift
39	74760644	Bolt	95	156970	Rod Asm Bypass PVST
40	4470J	Spacer, Split	96	4497H	Retainer Spring 1" Zinc/Cad
41	154777	Keeper, Belt, Idler	100	19111216	Washer 11/32 x 3/4 x 16 Ga.
42	19131312	Washer 13/32 x 13/16 x 12 Gauge	113	127285X	Strap Torque LH LT
47	127783	Pulley, Idler, V-Groove	116	72110610	Bolt Rdhd Sq. Neck 3/8-16 x 1.25
48	154604	Bellcrank Assembly	118	154774	Spacer Bellcrank
49	123205X	Retainer, Belt	121	154419	Nyliner Clutching STL
50	74760624	Bolt	122	156963	Plate Bypass PVST
51	73680600	Nut Crownlock 3/8-16 UNC	123	19081016	Washer 8/32 x 5/8 x 16 Ga.
52	73680500	Nut, Crownlock 5/16-18 Unc	124	156967	Spring Return PVST
53	105710X	Link, Clutch	125	74780516	Bolt Fin Hex 5/16-18 Unc x 1
55	105709X	Spring, Return, Clutch	126	1685H	Nut Lock 5/16-18 Unc

NOTE: All component dimensions give in U.S. inches.
1 inch = 25.4 mm.

REPAIR PARTS

TRACTOR - - MODEL NUMBER HD145H42D

STEERING ASSEMBLY

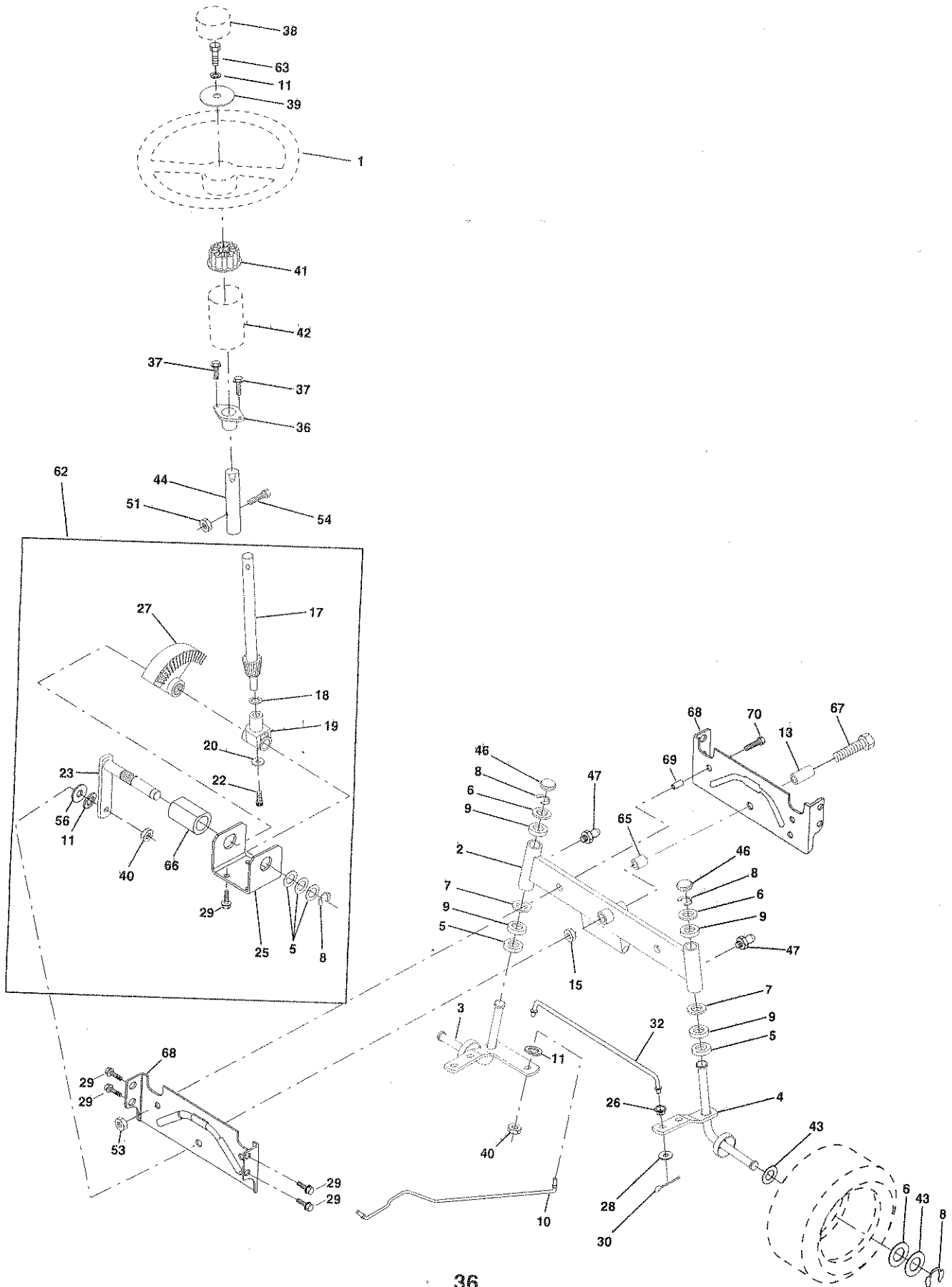

REPAIR PARTS

TRACTOR - - MODEL NUMBER HD145H42D

STEERING ASSEMBLY

KEY NO.	PART NO.	DESCRIPTION
1	140044	Wheel Steering Ayp/kelch Blk
2	154427	Axle Asm Fr
3	156483	Spindle Asm LH
4	157473	Spindle Asm RH
5	6266H	Bearing Race Thrust Harden
6	121748X	Washer 25/32 X 1-5/8 X 16 Ga
7	19272016	Washer 27/32 X 1-1/4 X 16 Ga
8	12000029	Ring Klip #t5304-75
9	3366R	Bearing Col Strg Blk
10	156438	Link Drag Extended Stamped
11	10040600	Washer Lock Hvy Hlcl Spr 3/8
13	154779	Bearing Axle
15	73901000	Nut Lock Flange 5/8-11 Unc
17	156546	Shaft Asm Strg
18	57079	Washer Thrust 515x 750x 033
19	124035X	Support Shaft
20	126684X	Washer Shim 1/4 X 5/8 X 062
21	10040400	Washer Lock Hvy Helical 1/4
22	71100410	Screw Cap Socket Head Phos & Oil
23	127501	Shaft Asm Pittman
25	154406	Bracket Steering
26	126847X	Bushing Link Drag Blk LR
27	136874	Gear Sector 22 Teeth
28	19131416	Washer 13/32 X 7/8 X 16 Ga
29	17490612	Screw Thdrol 3/8-16x3/4 Ty-tt
30	76020412	Pin Cotter 1/8 X 3/4 Cad
32	130465	Rod Tie Wire Form 19 75 Mech
36	155099	Bushing Steering
37	152927	Screw
38	140045	Cap Wheel Steer Ayp
39	19133808	Washer 13/32 x 2-3/8 x 8 Ga
40	7810H	Nut Lock Center 3/8-24 Unf
41	100711L	Adapter Wheel Strg
42	145054	Boot Dash P/L Steering
43	121749X	Washer 25/32 X 1 1/4 X 16 Ga
44	153720	Extension Steering
46	121232X	Cap Spindle Fr Top Blk
47	6855M	Fitting Grease
51	73800500	Nut Lock Hex W/Ins. 5/16-18 Unc P
53	73680600	Nut, Crownlock 3/8-16 Unc
54	74780520	Bolt Fin Hex 5/16-18 Unc P
62	156594	Kit Steering Assembly Service
63	74780616	Bolt Fin Hex 3/8-16unc x 1 Gr. 5
65	154780	Spacer Axle
66	154404	Bearing Arm Pittman
67	74781044	Bolt Fin Hex 5/8-11 Unc x 2-3/4
68	154429	Brace Axle
69	160367	Spacer, Brace Axle
70	74780636	Bolt, Fin Hex 3/8-16 Unc x 2-1/4

NOTE: All component dimensions given in U.S. inches
1 inch = 25.4 mm

REPAIR PARTS

TRACTOR - - MODEL NUMBER HD145H42D

SEAT ASSEMBLY

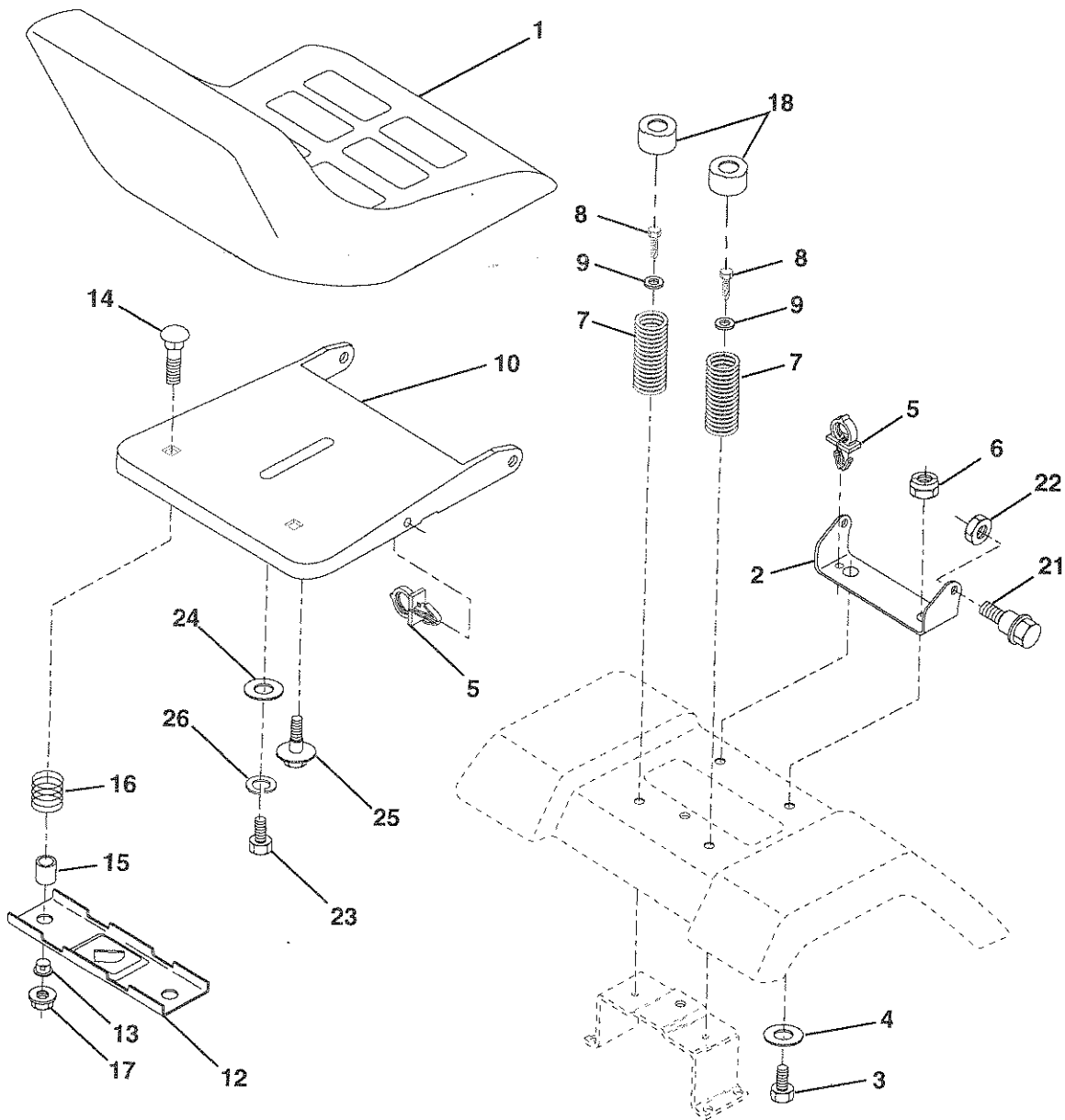

KEY NO.	PART NO.	DESCRIPTION
1	140116	Seat 2300/1316 Blk/blk AYPPL
2	140551	Bracket Pivot Seat 8 720
3	74760616	Bolt Fin Hex 3/8-16 Unc x 1
4	19131610	Washer Flat 13/32 x 1 x 10 Ga
5	145006	Clip Push In Hinged
6	73800600	Nut Crownlock 3/8-16 Unc
7	124181X	Spring Seat Cprsn 2 250 Blk Zi
8	17490616	Screw Thdrol 3/8-16 X 1 Ty-tt
9	19131614	Washer 13/32 X 1 X 14 Ga
10	155925	Pan Seat
12	121246X	Bracket Mounting Switch
13	121248X	Bushing Snap Blk Nyl 50 Id
14	72050411	Bolt Rdhd Sht Nk 1/4-20x1-3/8

KEY NO.	PART NO.	DESCRIPTION
15	134300	Spacer Split 28x 96 Yel Zinc
16	121250X	Spring Cprsn 1 27 Blk Pnt
17	123976X	Nut Lock 1/4 Lge Flg Gr 5 Zinc
18	124238X	Cap Spring Seat
21	153236	Bolt Shoulder 5/16-18 Unc Blkz
22	73680500	Nut Crown Lock 5/16-18
23	74780814	Bolt Fin Hex 1/2-13 X 7/8 Gr 5
24	19171912	Washer 17/32 X 1-3/16 X 12 Ga
25	127018X	Bolt Shoulder 5/16-18 X 62
26	10040800	Washer Lock Hvy Hlcl Spr 1/2

NOTE: All component dimensions given in U.S. inches
1 inch = 25.4 mm

REPAIR PARTS

TRACTOR -- MODEL NUMBER HD145H42D

DECALS

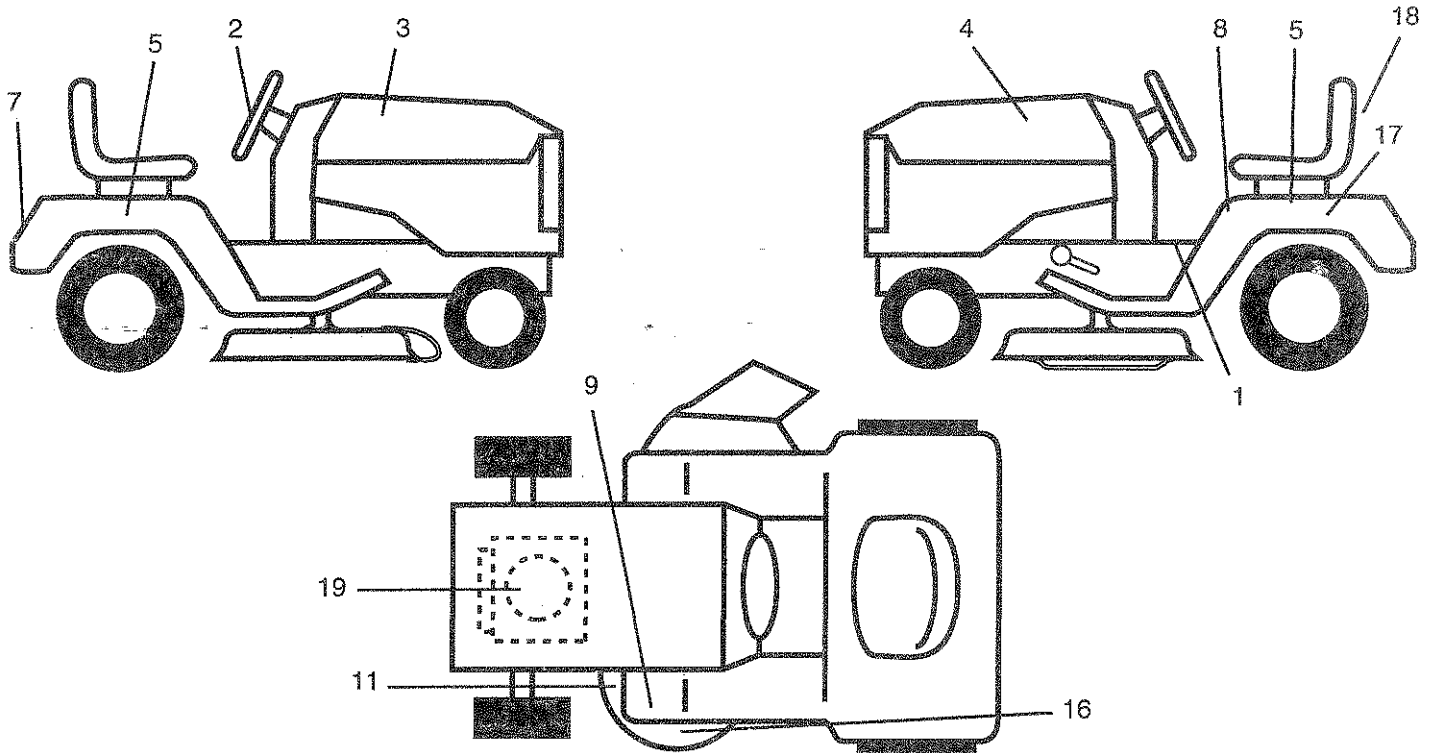

KEY NO.	PART NO.	DESCRIPTION
1	158181	Decal Saddle Inst. Oper Eng/Sp P/L
2	158168	Decal Steering Wheel Insert
3	158037	Decal Hood RH
4	158038	Decal Hood LH
5	158167	Decal Fender Sd Lawn
7	158166	Decal Fender Logo
8	157141	Decal Caution Fender Eng/Sp
9	141897	Decal Clutch/brake Eng/Sp
11	136832	Decal V-Belt Sch
16	158169	Decal Mulch Bag Poulan
17	145005	Decal Btry Dngr/Psn P/L Sym
18	158176	Decal Seat Acc

KEY NO.	PART NO.	DESCRIPTION
19	158172	Decal Replcment Engine
--	138311	Decal Handle Lft Height Adjust
--	160462	Manual Owner's English
--	160463	Manual Owner's Spanish
--	142341	Decal Drawbar Cntrl Mvt Hyd LT
Available accessories not included with tractor:		
--	LBD48	42" Snow Blade
--	LSB42	42" Snow Blower
--	LC05	Wheel Weights
--	C42	Grass Catcher
--	LC06	Tire Chains
--	MK420	Mulch Kit w/Blades

WHEELS AND TIRES

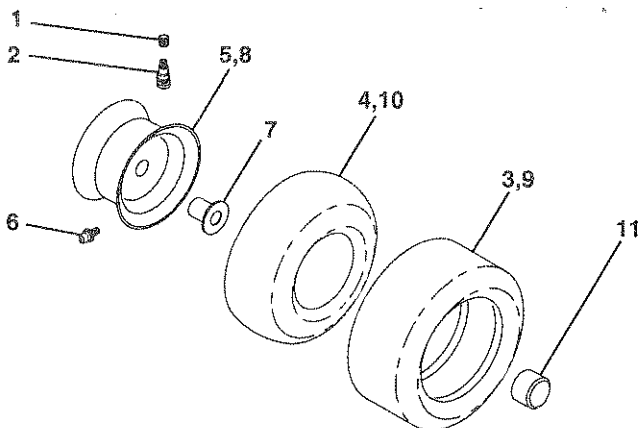

KEY NO.	PART NO.	DESCRIPTION
1	59192	Cap Valve Tire
2	65139	Stem Valve
3	106222X	Tire F Ts 15 X 6 0 - 6 Service
4	59904	Tube Front (Service Item Only)
5	106732X427	Rim Asm 6" front Yellow Service
6	278H	Fitting Grease (Front Wheel Only)
7	9040H	Bearing Flange (Front Wheel Only)
8	106108X427	Rim Asm 8" rear Yellow Service
9	106268X	Tire R Ts 18 x 9.5-8 C Service
10	7152J	Tube Rear (Service Item Only)
11	104757X	Cap Axle Blk 1 50 X 1 00
--	144334	Sealant, Tire (10 oz. Tube)

NOTE: All component dimensions given in U.S. inches
1 inch = 25.4 mm

REPAIR PARTS

TRACTOR - - MODEL NUMBER HD145H42D

ENGINE

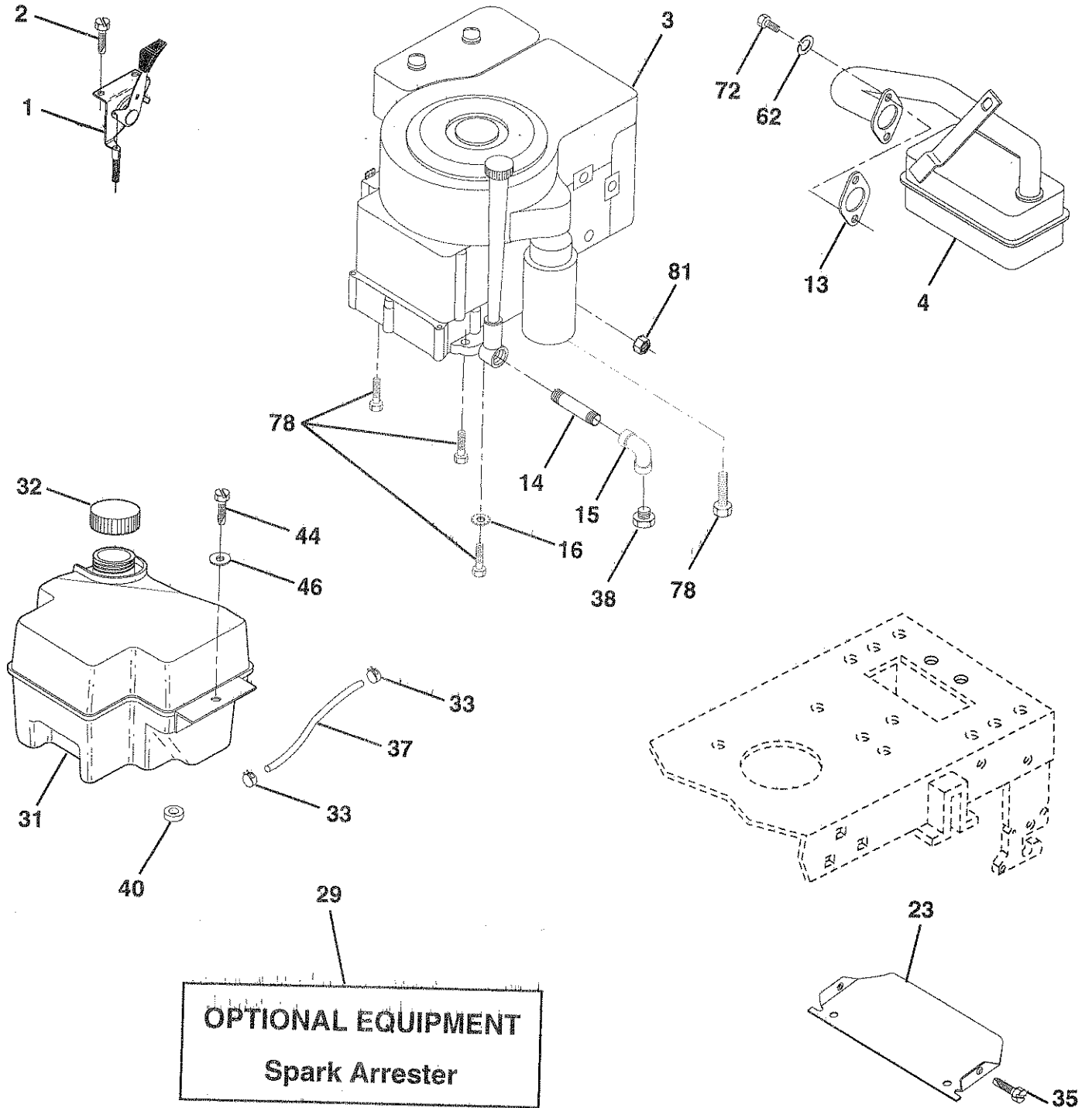

REPAIR PARTS

TRACTOR - - MODEL NUMBER HD145H42D

ENGINE

KEY NO.	PART NO.	DESCRIPTION
1	140310	Control Th/ch LH Flag 23.5
2	17720410	Screw Hex Thd Cut 1/4-20x5/8 T
3	-----	Engine B&S 287777
4	137352	Muffler Exhaust LT B&S 14HP IC OHV
13	272293	Gasket Eng 1 313 Id Tin Plated
14	13280324	Nipple Pipe 3/8 Npt X 3"
15	13200300	Elbow Std 90 Degree 3/8-18 Npt
16	11050600	Washer Lock Ext Tooth 3/8
23	156123	Shield Browning
29	137180	Kit Spark Arrestor (Flat Scrn)
31	140280	Tank Fuel Front
32	140527	Cap Asm Fuel
33	123487X	Clamp Hose
35	17490512	Screw Thdrol 5/16-18 x 3/4 TYT
37	137040	Line Fuel 20"
38	-----	Oil Drain Plug (Order From Engine Manufacturer)
40	124028X	Bushing Snap Nyl Blk Fuel Line
44	17490412	Screw Thdrol 1/4-20 x 3/4
46	19091416	Washer 9/32 x 7/8 x 16 Ga
62	10040500	Washer Lock Hvy Hlcl Spr 5/16
72	71070512	Screw Hex Hd Cap 5/16-18 x 3/4
78	17490620	Screw Thdrol 3/8-16x1-1/4 TYTT
81	128861	Nut Flange 1/4-20 Starter Nut

NOTE: All component dimensions given in U. S. inches
1 inch = 25.4 mm

REPAIR PARTS

TRACTOR - - MODEL NUMBER HD145H42D

LIFT

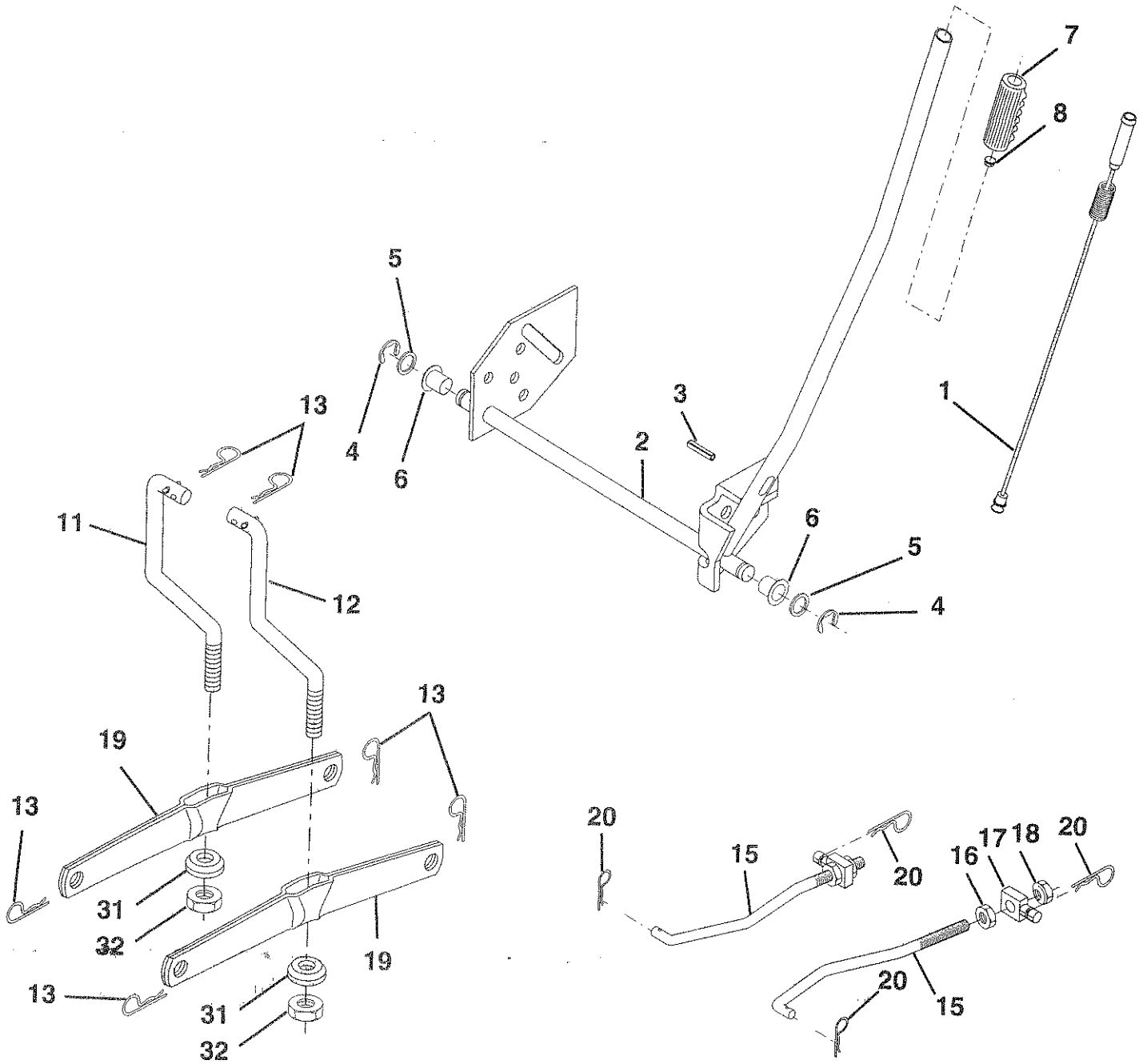

REPAIR PARTS

TRACTOR - - MODEL NUMBER HD145H42D

.LIFT

KEY NO.	PART NO.	DESCRIPTION
1	159460	Wire Asm Inner W/Plunger
2	159471	Shaft Asm Lft
3	105767X	Pin Groove
4	12000002	E-ring Truarc #5133-62
5	19211621	Washer Pltd 21/32 X 1 X 21 Ga
6	120183X	Bearing Nylon
7	109413X	Grip Handle Bicycle
8	124526X	Button Plunger Black
11	139865	Link Lift LH
12	139866	Link Lift RH
13	4939M	Retainer Spring
15	127218	Link Front
16	73350800	Nut Jam Hex 1/2-13 Unc
17	130171	Trunnion Blk Zinc
18	73800800	Nut Lock W/wsh 1/2-13unc
19	139868	Arm Suspension Rear
20	3146R	Retainer Spring
31	140302	Bearing Pvt. Lift Spherical
32	73540600	Nut Crownlock 3/8-24

NOTE: All component dimensions given in U.S. inches
1 inch = 25.4 mm

REPAIR PARTS

TRACTOR -- MODEL NUMBER HD145H42D

MOWER DECK

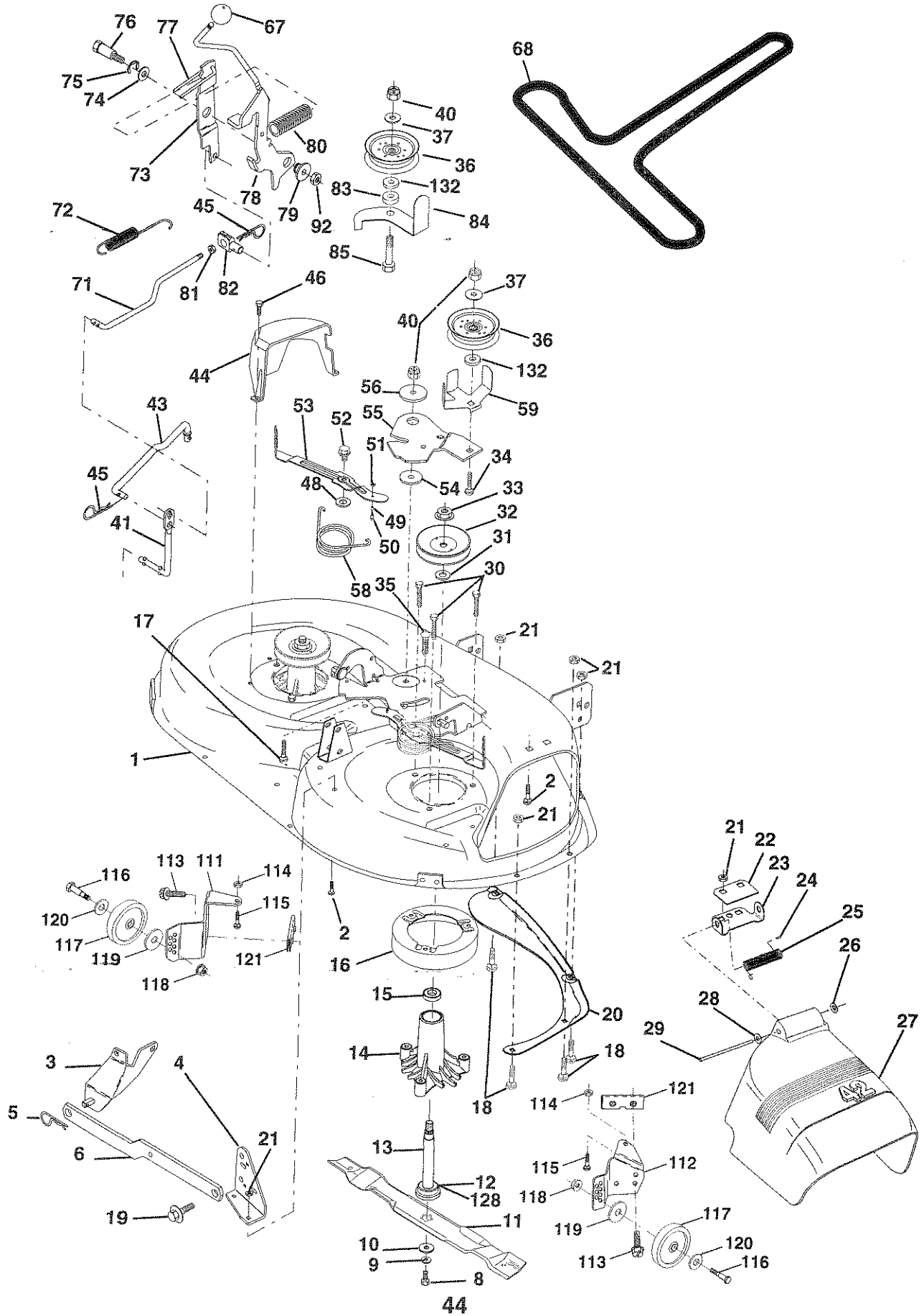

REPAIR PARTS

TRACTOR - - MODEL NUMBER HD145H42D

MOWER DECK

KEY NO.	PART NO.	DESCRIPTION	KEY NO.	PART NO.	DESCRIPTION
1	144393	Mower Housing	52	139888	Bolt Shoulder 5/16-18 Unc Blkz
2	72140506	Bolt Rdhd Sqnk 5/16-18unc X3/4	53	131845X900	Arm Asm Pad Brake
3	138017	Bracket Asm Fr Sway Bar 38/42	54	133943	Washer Hardened
4	138440	Bracket Asm Deck 42" sway Bar	55	155046	Arm Idler 42" mower LT/YT
5	4939M	Retainer Spring	56	122052X	Spacer Retainer Pm Mower
6	130832	Arm Suspension Rear	58	140086	Spring Torsion Brakes 42"
8	850857	Bolt 3/8-24 X 1 1/4	59	141043	Guard TUV Idler
9	10030600	Washer Lock Hvy 3/8	67	106932X	Knob Rd 3/8-16
10	140296	Washer Hard Blade Mower Vented	68	144200	V-Belt Mower
11	138498	Blade High Perf 42"	71	142427	Rod Clutch Primary 38/42
12	129895	Bearing Ball	72	131870	Spring Return
13	137645	Shaft Asm W/lower Bearing	73	127847	Arm Clutch Secondary
14	128774	Housing Mandrel Vented	74	121748X	Washer 25/32 X 1-5/8 X 16 Ga
15	110485X	Bearing Ball Mandrel	75	12000029	Ring Klip #t5304-75
16	140329	Stripper Mower Vented	76	128903	Bolt Shoulder 3/8-16 Unc 1 44
17	72110610	Bolt Rdhd Sqnk 3/8-16 X 1-1/4	77	127845	Keeper Spring 4 000
18	72140505	Bolt Rdhd Sqnk 5/16-18 X 5/8	78	154809	Lever Asm Clutch Primary P/L
19	132827	Bolt Shoulder	79	127498	Bushing 747 Od X 794 Lg Brass
20	136888	Baffle Vortex 42	80	153701	Spring Clutch Mower
21	73680500	Nut Crownlock 5/16-18 UNC	81	73350600	Nut Hex Jam 3/8-16 Unc
22	134753	Stiffener Bracket 42" deck	82	142028	Trunnion Adj
23	131267	Bracket Deflector Mower 42"	83	120958X	Washer Sintered
24	105304X	Cap Sleeve 80x 112 Blk Mower	84	156084	Keeper Belt Idler
25	123713X	Spring Torsion Deflector 2 52	85	72140618	Bolt Rdhd Sqnk 3/8-16 x 2-1/4
26	110452X	Nut Push Phos & Oil	92	73800600	Nut Lock Hex w/Ins 3/8-16 Unc
27	130968	Shield Deflector Mower 42" Blk	111	155197	Bracket Gauge Wheel Lh
28	19111016	Washer 11/32 X 5/8 X 16 Ga	112	155198	Bracket Gauge Wheel Rh
29	131491	Rod Hinge 42" 6 75 Wlg	113	17490512	Screw Thdrol 5/16-18 x 3/4
30	138776	Screw Thdrol Hex Head Zinc Mwr	114	73510500	Nut Keps 5/16-18 Unc
31	129963	Washer Spacer Mower Vented	115	72110504	Bolt Carr 5/16-Unc x 1/2
32	153535	Pulley Mandrel 42"	116	4898H	Bolt Shoulder
33	137266	Nut 9/16 Top Lock Flng	117	105455X	Wheel Gauge Blk
34	72110614	Bolt Rdhd 3/8-16uncx1-3/4 Gr5	118	73930600	Nut Centerlock 3/8-16 Unc
35	133835	Fastner Christmas Tree	119	19121414	Washer 3/8 x 7/8 x 14 Gauge
36	131494	Pulley Idler Flat 3 060	120	19171512	Washer 17/32 x 15/16 x 12 Gauge
37	19131316	Washer 13/32 x 13/16 x 16 Ga	121	143723	Bracket Extruded Gauge Wheel
40	73680600	Nut Crownlock 3/8-16 UNC	128	153390	Washer Felt
41	133551	Rod Pivot W/nibs	132	19132203	Washer 13/32 x 1-3/8 x 3 Ga.
43	140083	Rod Clutch Secondary W/nibs	--	130794	Mandrel Asm Service (Includes Key Nos. 8-10, 12-15, 31 and 33)
44	140088	Guard Mandrel LH Black	--	144783	Deck Serv (Std. Deck - Order seperately gauge wheel components 111-121.)
45	4497H	Spring Retainer 1" Zinc/cad			
46	137729	Screw Hex Thd Cut			
48	133944	Washer Hardened Smaller			
49	155066	Roller Asm Cam Follower 42" dec			
50	131340	Bolt Shldr 10-24 Zinc Gr 5 42"			
51	69180	Nut Lock #10-24 Unc			

NOTE: All component dimensions given in U.S. inches
1 inch = 25.4 mm

REPAIR PARTS

TRACTOR - - MODEL NUMBER HD145H42D

TRANSAXLE PEERLESS - MODEL NUMBER 205-027B

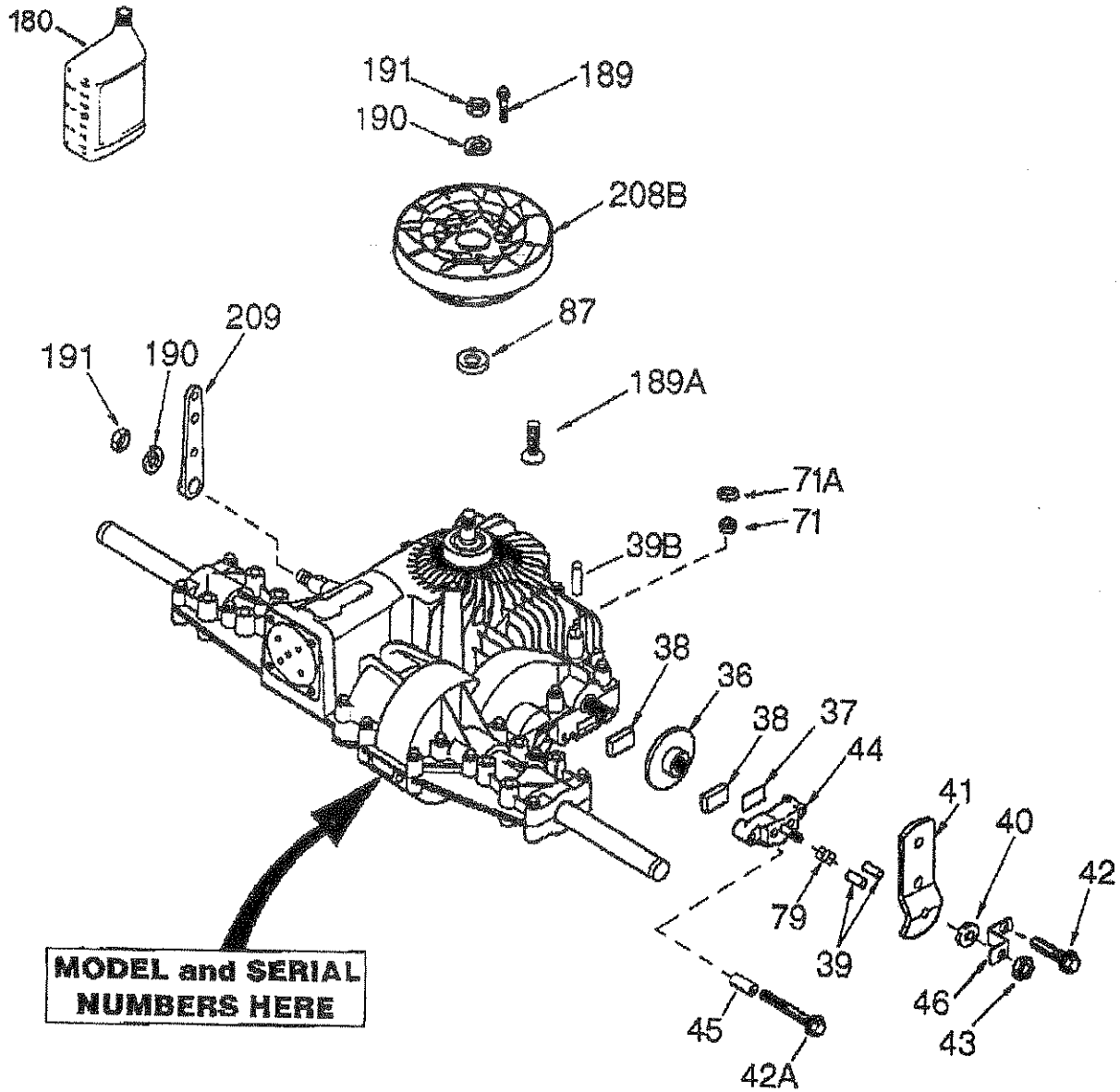

REF PART
NO. NO.

DESCRIPTION

36	790075	Brake Disc
37	790007	Brake Pad Plate
38	799021	Brake Pad (pkg of 2)
39	786026	Dowel Pin
39B	798033	Belt Guard
40	792076A	Flat Washer
41	790085	Brake Lever
42	792073	Screw, 1/4-20 x 1-1/4"
42A	792085A	Screw, 1/4-20 x 2-1/4"
43	792075	Locknut, 5/16-24
44	790025	Brake Pad Holder
45	786066	Spacer
46	790086	Brake Lever Bracket
71	788069	Square Cut Ring

REF PART
NO. NO.

DESCRIPTION

71A	792162	Pushnut, 9/16"
79	792144	Spring
87	788035	Oil Seal, 5/8"
180	730229A	Gear Oil 80W90
189	792168	Drive Screw #6 x 1/2"
189A	792169	Screw, 10-32 x 1/2"
190	792150	Lockwasher
191	792151	Nut, 7/16-20
208B	798025	Fan/Coupling (Incl. 189 & 189A)
209	798024	Control Lever

Parts must be ordered from Tecumseh Products Co.
NOTE: All component dimensions given in U.S. inches
 1 inch = 25.4 mm

SERVICE NOTES

SERVICE NOTES

LIMITED WARRANTY

The Manufacturer warrants to the original consumer purchaser that this product as manufactured is free from defects in materials and workmanship. For a period of two (2) years from date of purchase by the original consumer purchaser, we will repair or replace, at our option, without charge for parts or labor incurred in replacing parts, any part which we find to be defective due to materials or workmanship. This Warranty is subject to the following limitations and exclusions.

1. This warranty does not apply to the engine, other than AYP manufactured transaxle/transmission components, battery (except as noted below) or components parts thereof. Please refer to the applicable manufacturer's warranty on these items.
2. Transportation charges for the movement of any power equipment unit or attachment are the responsibility of the purchaser. Transportation charges for any parts submitted for replacement under this warranty must be paid by the purchaser unless such return is requested by American Yard Products.
3. Battery Warranty: On products equipped with a Battery, we will replace, without charge to you, any battery which we find to be defective in manufacture, during the first ninety (90) days of ownership. After ninety (90) days, we will exchange the Battery, charging you 1/12 of the price of a new Battery for each full month from the date of the original sale. Battery must be maintained in accordance with the instructions furnished.
4. The Warranty period for any products used for rental or commercial purposes is limited to 90 days from the date of original purchase.
5. This Warranty applies only to products which have been properly assembled, adjusted, operated, and maintained in accordance with the instructions furnished. This Warranty does not apply to any product which has been subjected to alteration, misuse, abuse, improper assembly or installation, delivery damage, or to normal wear of the product.
6. Exclusions: Excluded from this Warranty are belts, blades, blade adapters, normal wear, normal adjustments, standard hardware and normal maintenance.
7. In the event you have a claim under this Warranty, you must return the product to an authorized service dealer.

Should you have any unanswered questions concerning this Warranty, please contact:

American Yard Products
Service Department
P.O. Box 1687
Orangeburg, SC 29116 USA

In Canada contact:
American Yard Products
1580 Trinity Drive, Units 5-8
Mississauga, Ontario
L5T 1L6

giving the model number, serial number and date of purchase of your product and the name and address of the authorized dealer from whom it was purchased.

THIS WARRANTY DOES NOT APPLY TO INCIDENTAL OR CONSEQUENTIAL DAMAGES AND ANY IMPLIED WARRANTIES ARE LIMITED TO THE SAME TIME PERIODS STATED HEREIN FOR OUR EXPRESSED WARRANTIES. Some areas do not allow the limitation of consequential damages or limitations of how long an implied Warranty may last, so the above limitations or exclusions may not apply to you. This Warranty gives you specific legal rights, and you may have other rights which vary from locale to locale.

This is a limited Warranty within the meaning of that term as defined in the Magnuson-Moss Act of 1975.

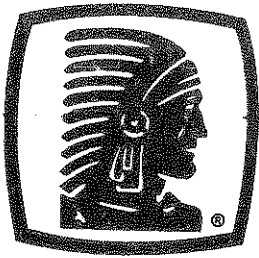

TECUMSEH

SERVICE POLICY WARRANTY

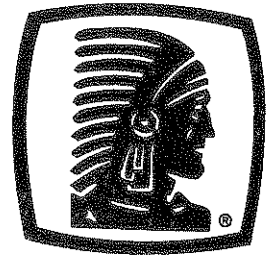

TECUMSEH

Issued January 1980
Revised January 1991

LIMITED WARRANTIES FOR NEW PEERLESS GEAR POWER TRAIN COMPONENTS

A. Products Warranted

Peerless Gear and Machine Division of Tecumseh Products Company ("Tecumseh"), subject to the limitations contained below, will, at its option, repair or replace, without charge for parts or labor only, any part of a new Power Train Component (which as used herein means and includes the transaxle, gear box, transmission, differential and right angle drives, and any part of the Power Train Component), EXCEPT any new Power Train Component incorporated in equipment used for commercial or rental purposes, which is found upon examination by any Tecumseh Authorized Service Outlet or by Tecumseh's factory in Grafton, Wisconsin, to be DEFECTIVE IN MATERIAL AND/OR WORKMANSHIP if received by Tecumseh or a Tecumseh Authorized Service Outlet for such examination within TWO YEARS from the date of sale to the original consumer purchaser of Peerless Series 820, 900, 910, 915, 920, 930 transaxles and Series 1100 angle drive and ONE YEAR for all other Peerless products. New Power Train Components incorporated in equipment used for commercial purposes are warranted in the same manner and to the same extent EXCEPT such Power Train Components are warranted for NINETY (90) DAYS ONLY, and must be received by Tecumseh or by a Tecumseh Authorized Service Outlet for such examination within 90 days from the date of sale to the original purchaser. New Power Train Components incorporated in equipment used for rental purposes are warranted in the same manner and to the same extent EXCEPT such Power Train Components are warranted for THIRTY (30) DAYS ONLY, and must be received by Tecumseh or a Tecumseh Authorized Service Outlet within 30 days from the date of sale to the original purchaser.

B. Products And Items Not Warranted

1. Alterations or Modifications of Power Train Components.
2. Accidents, Normal Maintenance, Failure to follow the Original Equipment Manufacturer's Manual.

This warranty covers only parts of new Power Train Components which are found upon examination to be defective in material or workmanship as delivered to the original purchaser. This warranty does not cover defects caused by depreciation or damage caused by normal wear, accidents, improper maintenance, improper use or abuse of the product, failure to follow the instructions contained in an Instruction Manual for the operation of the Power Train Component and parts. The cost of normal maintenance and replacement of service items which are not defective shall be paid for by the original purchaser.

C. Securing Warranty Service

Warranty service can be arranged for by contacting either a Tecumseh Authorized Service Outlet (any Tecumseh Registered Service Dealer, Tecumseh Authorized Service Distributor, or Tecumseh Central Warehouse Distributor) or by contacting Tecumseh, c/o Service Manager, Engine and Transmission Group Service Division, 900 North Street, Grafton, Wisconsin 53024. Warranty service can only be performed by a Tecumseh Authorized Service Outlet or by Tecumseh at its factory in Grafton, Wisconsin. At the time of requesting warranty service, evidence must be presented of the date of sale to the original purchaser. The purchaser shall pay any charges for making service calls and/or for transporting the product to and from the place where the inspection and/or warranty work is performed. The purchaser shall be responsible for any damage or loss incurred in connection with the transportation of Power Train Components and/or part(s) of the Power Train Components submitted for inspection and/or warranty work.

D. Limitation of Damages and Implied Warranties

The foregoing EXPRESSED WARRANTY IS IN LIEU OF ALL OTHER EXPRESS WARRANTIES. Neither Tecumseh nor any of its affiliates makes any warranties, representations or promises, written or oral, as to the quality of the Power Train Component or any of its parts, other than as set forth herein.

ANY IMPLIED WARRANTY OF MERCHANTABILITY OR FITNESS FOR A PARTICULAR PURPOSE, TO THE EXTENT THAT EITHER MAY APPLY TO ANY PART(S) OF POWER TRAIN COMPONENTS, SHALL BE LIMITED IN DURATION TO THE PERIODS OF THE EXPRESSED WARRANTIES DEFINED IN PARAGRAPH A HEREOF. IN NO EVENT WILL TECUMSEH BE LIABLE FOR ANY INCIDENTAL, CONSEQUENTIAL OR SPECIAL DAMAGES AND/OR EXPENSES. Some states do not allow limitations on how long an implied warranty lasts or the exclusion or limitation of incidental or consequential damages, so the above limitation(s) or exclusion(s) may not apply to you. This warranty gives you specific legal rights and you may also have other legal rights which vary from state to state.

E. No Dealer Warranty

Tecumseh neither assumes nor authorizes any other person, natural or corporate, to assume for Tecumseh any other obligations or liabilities in connection with or with respect to any part(s) of a Power Train Component. The seller or dealer of part(s) of a Power Train Component has no authority, whatsoever, to make any representations or promises on behalf of Tecumseh or to modify the terms or limitations of Tecumseh's warranty in any way.

SUGGESTED GUIDE FOR SIGHTING SLOPES FOR SAFE OPERATION

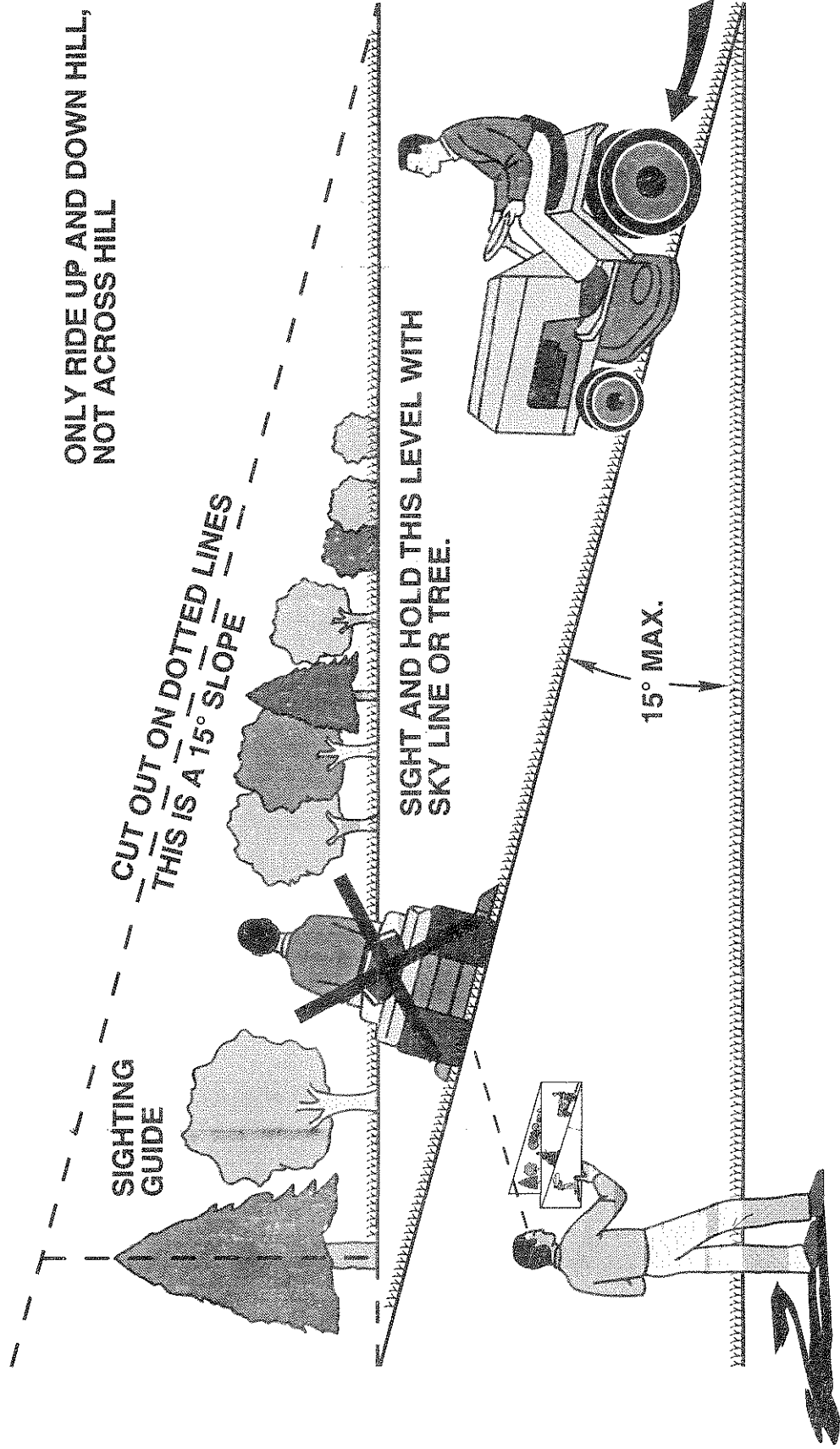

 Operate your Tractor up and down the face of slopes (not greater than 15°), never across the face. Make turns gradually to prevent tipping or loss of control. Exercise extreme caution when changing direction on slopes.

Poulan