

# LTH130



This product has a low emission engine which operates differently from previously built engines. Before you start the engine, read and understand this Owner's Manual.

**Owner's Manual**



# SAFETY RULES



## Safe Operation Practices for Ride-On Mowers

**IMPORTANT:** THIS CUTTING MACHINE IS CAPABLE OF AMPUTATING HANDS AND FEET AND THROWING OBJECTS. FAILURE TO OBSERVE THE FOLLOWING SAFETY INSTRUCTIONS COULD RESULT IN SERIOUS INJURY OR DEATH.

### I. GENERAL OPERATION

- Read, understand, and follow all instructions in the manual and on the machine before starting.
- Only allow responsible adults, who are familiar with the instructions, to operate the machine.
- Clear the area of objects such as rocks, toys, wire, etc., which could be picked up and thrown by the blade.
- Be sure the area is clear of other people before mowing. Stop machine if anyone enters the area.
- Never carry passengers.
- Do not mow in reverse unless absolutely necessary. Always look down and behind before and while backing.
- Be aware of the mower discharge direction and do not point it at anyone. Do not operate the mower without either the entire grass catcher or the guard in place.
- Slow down before turning.
- Never leave a running machine unattended. Always turn off blades, set parking brake, stop engine, and remove keys before dismounting.
- Turn off blades when not mowing.
- Stop engine before removing grass catcher or unclogging chute.
- Mow only in daylight or good artificial light.
- Do not operate the machine while under the influence of alcohol or drugs.
- Watch for traffic when operating near or crossing roadways.
- Use extra care when loading or unloading the machine into a trailer or truck.

### II. SLOPE OPERATION

Slopes are a major factor related to loss-of-control and tipover accidents, which can result in severe injury or death. All slopes require extra caution. If you cannot back up the slope or if you feel uneasy on it, do not mow it.

#### DO:

- Mow up and down slopes, not across.
- Remove obstacles such as rocks, tree limbs, etc.
- Watch for holes, ruts, or bumps. Uneven terrain could overturn the machine. *Tall grass can hide obstacles.*
- Use slow speed. Choose a low gear so that you will not have to stop or shift while on the slope.
- Follow the manufacturer's recommendations for wheel weights or counterweights to improve stability.
- Use extra care with grass catchers or other attachments. These can change the stability of the machine.
- Keep all movement on the slopes *slow* and *gradual*. Do not make sudden changes in speed or direction.
- Avoid starting or stopping on a slope. If tires lose traction, disengage the blades and proceed slowly *straight* down the slope.

#### DO NOT:

- *Do not* turn on slopes unless necessary, and then, turn slowly and gradually downhill, if possible.
- *Do not* mow near drop-offs, ditches, or embankments. The mower could suddenly turn over if a wheel is over the edge of a cliff or ditch, or if an edge caves in.
- *Do not* mow on wet grass. Reduced traction could cause sliding.
- *Do not* try to stabilize the machine by putting your foot on the ground.
- *Do not* use grass catcher on steep slopes.

### III. CHILDREN

Tragic accidents can occur if the operator is not alert to the presence of children. Children are often attracted to the machine and the mowing activity. *Never* assume that children will remain where you last saw them.

- Keep children out of the mowing area and under the watchful care of another responsible adult.
- Be alert and turn machine off if children enter the area.
- Before and when backing, look behind and *down* for small children.
- Never carry children. They may fall off and be seriously injured or interfere with safe machine operation.
- Never allow children to operate the machine.
- Use extra care when approaching blind corners, shrubs, trees, or other objects that may obscure vision.

### IV. SERVICE

- Use extra care in handling gasoline and other fuels. They are flammable and vapors are explosive.
  - Use only an approved container.
  - Never remove gas cap or add fuel with the engine running. Allow engine to cool before refueling. Do not smoke.
  - Never refuel the machine indoors.
  - Never store the machine or fuel container inside where there is an open flame, such as a water heater.
- Never run a machine inside a closed area.
- Keep nuts and bolts, especially blade attachment bolts, tight and keep equipment in good condition.
- Never tamper with safety devices. Check their proper operation regularly.
- Keep machine free of grass, leaves, or other debris build-up. Clean oil or fuel spillage. Allow machine to cool before storing.
- Stop and inspect the equipment if you strike an object. Repair, if necessary, before restarting.
- Never make adjustments or repairs with the engine running.
- Grass catcher components are subject to wear, damage, and deterioration, which could expose moving parts or allow objects to be thrown. Frequently check components and replace with manufacturer's recommended parts, when necessary.
- Mower blades are sharp and can cut. Wrap the blade(s) or wear gloves, and use extra caution when servicing them.
- Check brake operation frequently. Adjust and service as required.



**Look for this symbol to point out important safety precautions. It means CAUTION!!! BECOME ALERT!!! YOUR SAFETY IS INVOLVED.**



**CAUTION: Always disconnect spark plug wire and place wire where it cannot contact spark plug in order to prevent accidental starting when setting up, transporting, adjusting or making repairs.**



**WARNING**  
The engine exhaust from this product contains chemicals known to the State of California to cause cancer, birth defects, or other reproductive harm.

**CONGRATULATIONS** on your purchase of a new tractor. It has been designed, engineered and manufactured to give you the best possible dependability and performance.

Should you experience any problem you cannot easily remedy, please contact your nearest authorized service center/department. We have competent, well-trained technicians and the proper tools to service or repair this unit.

Please read and retain this manual. The instructions will enable you to assemble and maintain your unit properly. Always observe the "SAFETY RULES".

MODEL NUMBER	LTH130
SERIAL NUMBER	_____
DATE OF PURCHASE	_____
THE MODEL AND SERIAL NUMBERS WILL BE FOUND ON A PLATE UNDER THE SEAT.	
YOU SHOULD RECORD BOTH SERIAL NUMBER AND DATE OF PURCHASE AND KEEP IN A SAFE PLACE FOR FUTURE REFERENCE.	

### CUSTOMER RESPONSIBILITIES

- Read and observe the safety rules.
- Follow a regular schedule in maintaining, caring for and using your tractor.
- Follow the instructions under "Customer Responsibilities" and "Storage" sections of this owner's manual.

### PRODUCT SPECIFICATIONS

HORSEPOWER:	13.0
GASOLINE CAPACITY AND TYPE:	2 GALLONS UNLEADED REGULAR
OIL TYPE (API-SF/SG/SH):	SAE 10W30 (above 32°F) SAE 5W-30 (below 32°F)
OIL CAPACITY:	W/ FILTER: 4.0 PINTS W/O FILTER: 3.5 PINTS
SPARK PLUG: (GAP: .040")	CHAMPION RC12YC
VALVE CLEARANCE:	NOT ADJUSTABLE
GROUND SPEED (MPH):	FORWARD: 5.70 REVERSE: 2.70
TIRE PRESSURE:	FRONT: 14 PSI REAR: 12 PSI
CHARGING SYSTEM:	3 AMPS BATTERY 5 AMPS HEADLIGHTS
BATTERY:	AMP/HR: 25 MIN. CCA: 190 CASE SIZE: U1R
BLADE BOLT TORQUE:	27-35 FT. LBS.

**WARNING:** This tractor is equipped with an internal combustion engine and should not be used on or near any unimproved forest-covered, brush-covered or grass-covered land unless the engine's exhaust system is equipped with a spark arrester meeting applicable local or state laws (if any). If a spark arrester is used, it should be maintained in effective working order by the operator.

A spark arrester for the muffler is available through your nearest authorized service center/department (See REPAIR PARTS section of this manual).

# TABLE OF CONTENTS

SAFETY RULES .....	2	MAINTENANCE SCHEDULE .....	16
PRODUCT SPECIFICATIONS .....	3	SERVICE AND ADJUSTMENTS .....	20-24
CUSTOMER RESPONSIBILITIES .....	3, 16-19	STORAGE .....	25
ASSEMBLY .....	6-9	TROUBLESHOOTING .....	26-27
OPERATION .....	11-15	REPAIR PARTS - TRACTOR .....	30-47
		WARRANTY .....	51

## INDEX

<b>A</b>	Adjustments:	Brake .....	21	Carburetor .....	24	Mower	Front-To-Back .....	21	Side-To-Side .....	20	Throttle Control Cable .....	24	Air Filter, Engine .....	18	Air Screen, Engine .....	19	Assembly .....	6-9																							
<b>B</b>	Battery:	Charging .....	7	Cleaning .....	17	Levels .....	18	Connection .....	6,7	Starting with Weak Battery .....	23	Storage .....	25	Terminals .....	18																										
	Belt:	Motion Drive	Removal/Replacement .....	22	Mower Belt(s)	Removal/Replacement .....	22																																		
	Blade:	Sharpening .....	17	Replacement .....	17																																				
	Brake Adjustment .....	21																																							
<b>C</b>	Carburetor Adjustment .....	24	Controls, Tractor .....	11	Customer Responsibilities .....	16-19	Engine:	Air Filter .....	18	Air Screen .....	19	Cooling Fins .....	19	Engine Oil .....	13,18	Fuel Filter .....	19	Spark Plug(s) .....	19	Tractor:	Battery .....	17	Blade .....	17	Lubrication Chart .....	16	Maintenance Schedule .....	16	Tire Care .....	9,17,22	Transaxle .....	17	Cutting Height, Mower .....	12							
<b>E</b>	Electrical:	Interlocks and Relays .....	23	Schematic .....	29	Wiring Diagram .....	30																																		
	Engine:	Air Filter .....	18	Air Screen .....	19	Cooling Fins .....	19	Oil Change .....	18	Oil Level .....	13	Oil Type .....	13,18	Preparation .....	13	Starting .....	14	Storage .....	25																						
<b>F</b>	Filter:	Air Filter .....	18	Fuel .....	19	Fuel:	Type .....	13	Storage .....	25	Fuse .....	23																													
<b>H</b>	Hood Removal/Installation .....	23																																							
<b>L</b>	Leveling Mower Deck .....	20																																							
	Lubrication:	Chart .....	16	Engine .....	18																																				
<b>M</b>	Maintenance Schedule .....	16	Mower:	Adjustment, Front-to-Back .....	21	Adjustment, Side-to-Side .....	20	Blade Replacement .....	17	Blade Sharpening .....	17	Cutting Height .....	12	Installation .....	20	Operation .....	12	Removal .....	20	Mowing Tips .....	15	Muffler .....	19	Spark Arrester .....	3,38																
<b>O</b>	Oil:	Cold Weather Conditions .....	13,18	Engine .....	18	Storage .....	25																																		
	Operation .....	11-15	Operating Mower .....	13	Options:	Spark Arrester .....	3,38																																		
<b>P</b>	Parking Brake .....	11-12	Parts Bag .....	5	Parts, Replacement/Repair .....	30-47	Product Specifications .....	2																																	
<b>R</b>	Repair Parts .....	30-47																																							
<b>S</b>	Safety Rules .....	2	Seat .....	7	Service and Adjustments .....	20-24	Carburetor .....	24	Fuse .....	23	Hood Removal/Installation .....	23	Motion Drive Belt	Removal/Replacement .....	22	Mower Belt(s)	Removal/Replacement .....	21	Mower Adjustment	Front-to-Back .....	21	Side-to-Side .....	20	Mower Removal/Installation .....	20	Tire Care .....	9,17,22	Slope Guide Sheet .....	50	Spark Plug(s) .....	19	Specifications .....	3	Starting the Engine .....	13	Steering Wheel .....	6,22	Stopping the Tractor .....	12	Storage .....	25
<b>T</b>	Throttle Control Cable Adjustment .....	24	Tires .....	9,17,22	Troubleshooting Chart .....	26-27	Transaxle .....	17																																	
<b>W</b>	Warranty .....	51	Wiring Diagram .....	30	Wiring Schematic .....	29																																			



# CONTENTS OF HARDWARE PACK

## Parts Bag contents shown full size

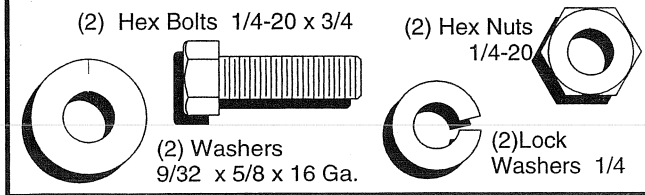
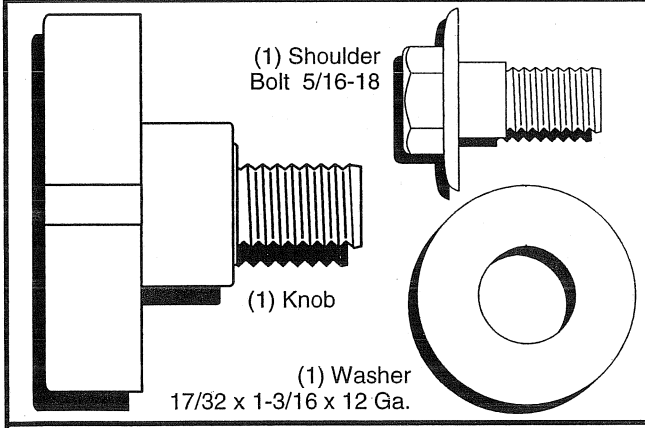
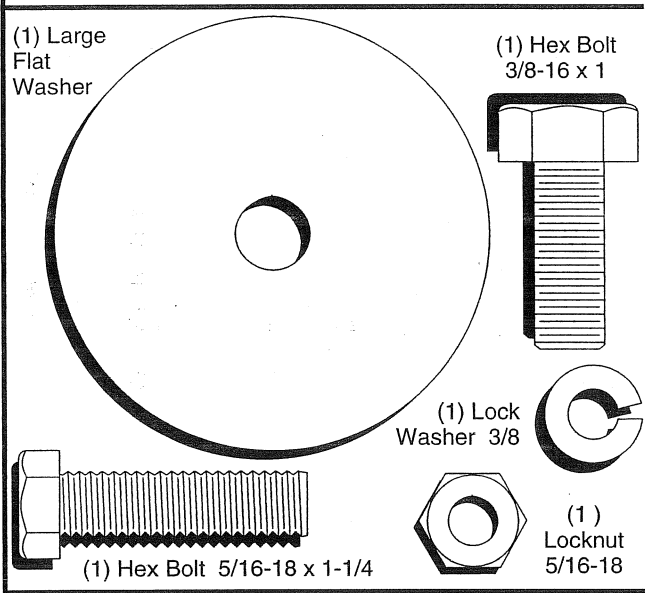
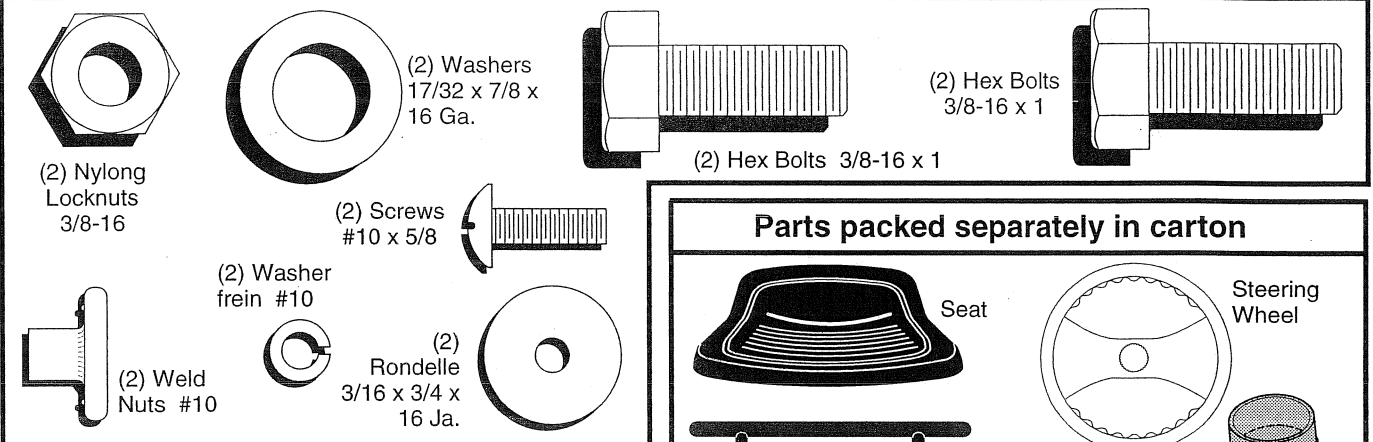

## Parts packed separately in carton

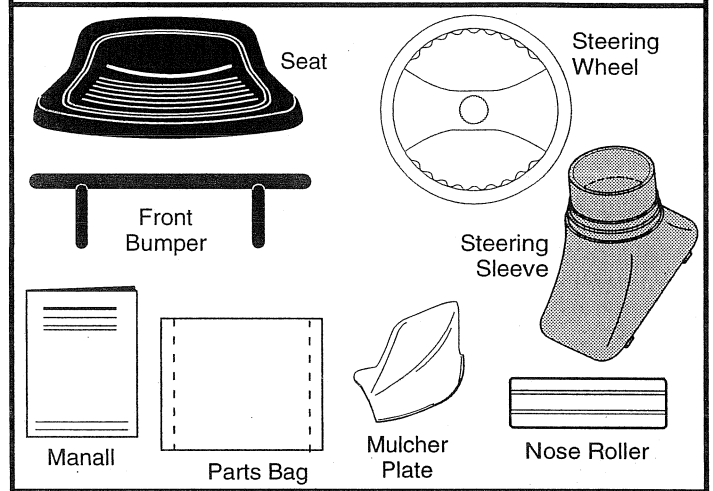

## Parts bag contents not shown full size

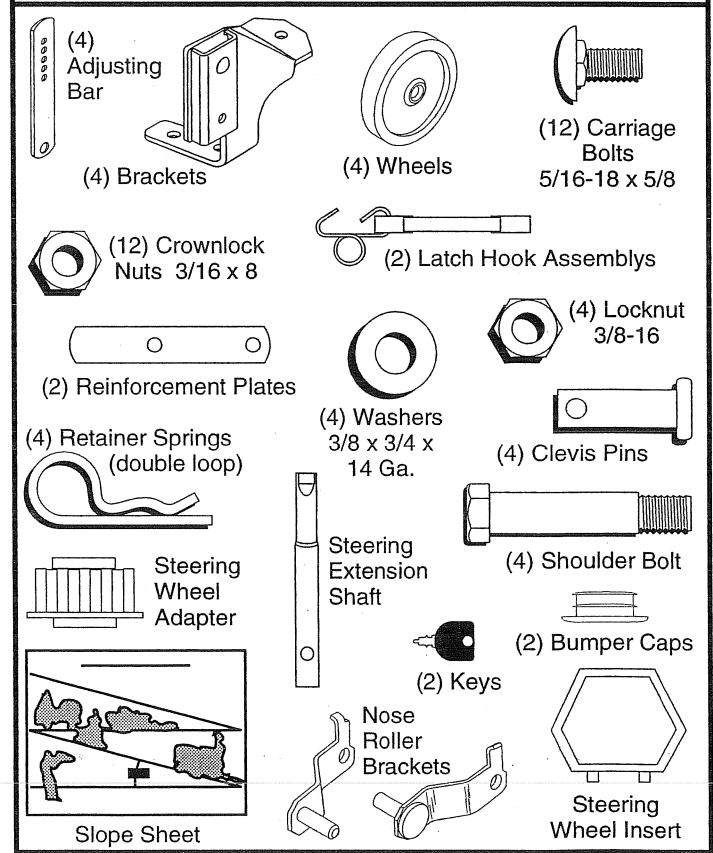

# ASSEMBLY

Your new tractor has been assembled at the factory with exception of those parts left unassembled for shipping purposes. To ensure safe and proper operation of your tractor all parts and hardware you assemble must be tightened securely. Use the correct tools as necessary to insure proper tightness.

## TOOLS REQUIRED FOR ASSEMBLY

A socket wrench set will make assembly easier. Standard wrench sizes are listed.

- (2) 7/16" wrenches Phillips Screwdriver
- (2) 1/2" wrenches Tire pressure gauge
- (2) 9/16" wrenches Utility knife
- (1) 3/4" socket with drive ratchet

When right or left hand is mentioned in this manual, it means when you are in the operating position (seated behind the steering wheel).

## TO REMOVE TRACTOR FROM CARTON

### UNPACK CARTON

- Remove all accessible loose parts and parts cartons from carton (See page 5).
- Cut, from top to bottom, along lines on all four corners of carton, and lay panels flat.
- Check for any additional loose parts or cartons and remove.

## BEFORE ROLLING TRACTOR OFF SKID

### ATTACH STEERING WHEEL (See Fig. 1)

#### ASSEMBLE EXTENSION SHAFT AND BOOT

- Slide extension shaft onto lower steering shaft. Align mounting holes in extension and lower shafts and install 5/16 hex bolt and locknut. Tighten securely.

**IMPORTANT:** TIGHTEN BOLT AND NUT SECURELY TO 18-22 FT. LBS TORQUE.

- Place tabs of steering boot over tab slots in dash and push down to secure.

#### INSTALL STEERING WHEEL

- Position front wheels of the tractor so they are pointing straight forward.
- Slide steering wheel adapter onto steering shaft extension.
- Position steering wheel so cross bars are horizontal (left to right) and slide inside boot and onto adapter.
- Assemble large flat washer, 3/8 lock washer, 3/8 hex bolt and tighten securely.
- Snap steering wheel insert into center of steering wheel.
- Remove protective materials from tractor hood and grill.

**IMPORTANT:** CHECK FOR AND REMOVE ANY STAPLES IN SKID THAT MAY PUNCTURE TIRES WHERE TRACTOR IS TO ROLL OFF SKID.

## TO ROLL TRACTOR OFF SKID (See Operation section for location and function of controls)

- Press lift lever plunger and raise attachment lift lever to its highest position.
- Release parking brake by depressing clutch/brake pedal.
- Place freewheel control in freewheeling position to disengage transmission (See "TO TRANSPORT" in the Operation section of this manual).
- Roll tractor backwards off skid.
- Remove banding holding discharge guard up against tractor.

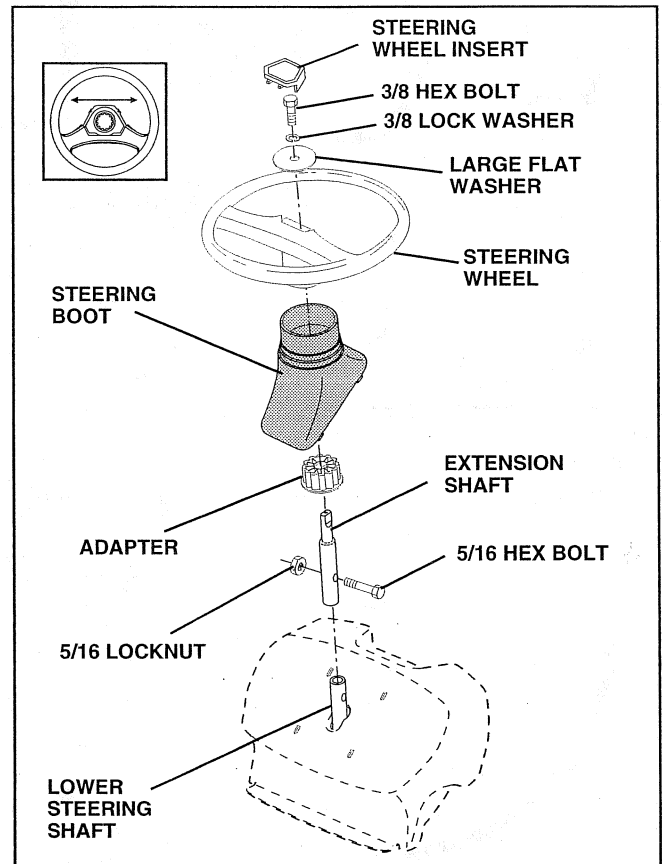

FIG. 1

## HOW TO SET UP YOUR TRACTOR CONNECT BATTERY (See Figs. 2 and 3)



**CAUTION:** Do not short battery terminals by allowing a wrench or any other object to contact both terminals at the same time. Before connecting battery, remove metal bracelets, wristwatch bands, rings, etc. Positive terminal must be connected first to prevent sparking from accidental grounding.

- Remove cardboard packing from seat pan and lift seat pan to raised position.
- Open battery box door and remove protective plastic.
- Remove terminal protective caps and discard.
- If this battery is put into service after month and year indicated on label (label located between terminals) charge battery for minimum of one hour at 6-10 amps.
- First connect RED battery cable to positive (+) terminal with hex bolt, flat washer, lock washer and hex nut as shown. Tighten securely.
- Connect BLACK grounding cable to negative (-) terminal with remaining hex bolt, flat washer, lock washer and hex nut. Tighten securely.
- Close battery box door.

# ASSEMBLY

Open battery box door for:

- Inspection for secure connections (to tighten hardware).
- Inspection for corrosion.
- Testing battery.
- Jumping (if required).
- Periodic charging .

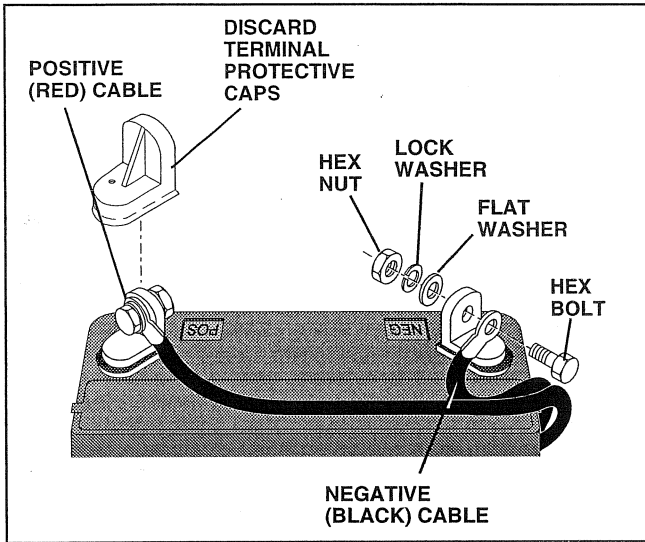

FIG. 2

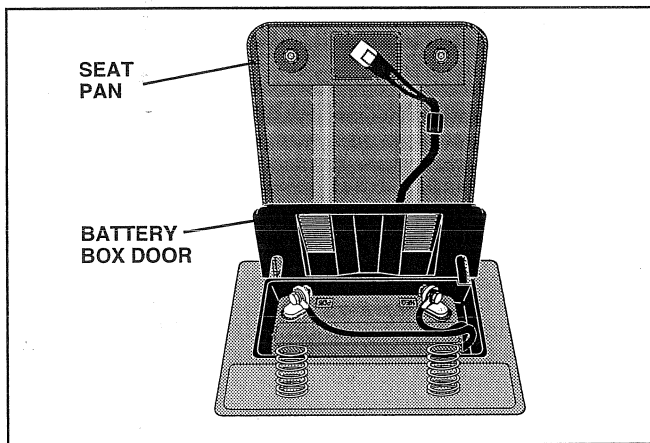

FIG. 3

## INSTALL SEAT (See Fig. 4)

Adjust seat before tightening adjustment knob.

- Remove cardboard packing on seat pan.
- Place seat on seat pan and assemble shoulder bolt. Tighten shoulder bolt securely.
- Assemble adjustment knob and flat washer loosely. Do not tighten.
- Lower seat into operating position and sit on seat.
- Slide seat until a comfortable position is reached which allows you to press clutch/brake pedal all the way down.
- Get off seat without moving its adjusted position.
- Raise seat and tighten adjustment knob securely.

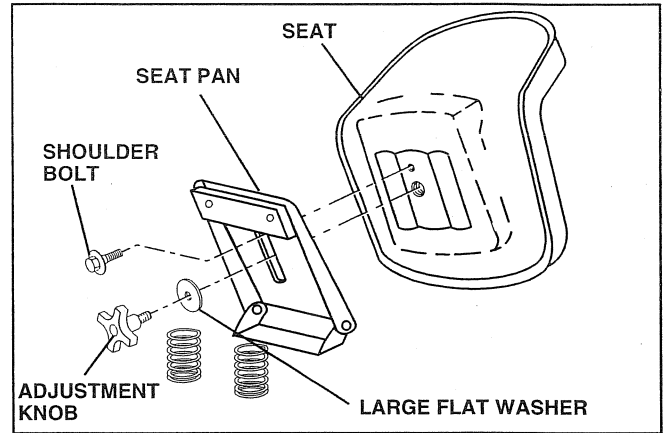

FIG. 4

## TO ATTACH FRONT BUMPER (See Fig. 5)

**NOTE:** For ease of assembly, you may wish to obtain the assistance of another person for mounting bumper to tractor.

- Press or tap the end caps into ends of bumper tube.
- The existing top screw and the existing front screw must be removed from both sides.
- On both sides of chassis, position extension bracket as shown and loosely assemble to rear chassis hole with supplied 3/8-16 x 1-1/4 screw. Do not tighten the brackets. Allow them to hang from the chassis.
- Position bumper and extension brackets so brackets can be slid inside flattened ends of bumper.
- Slide bumper onto brackets and pivot upwards to align center holes in extension brackets and tractor chassis.
- With holes aligned, install additional screws.
- Tighten all four (4) screws securely.

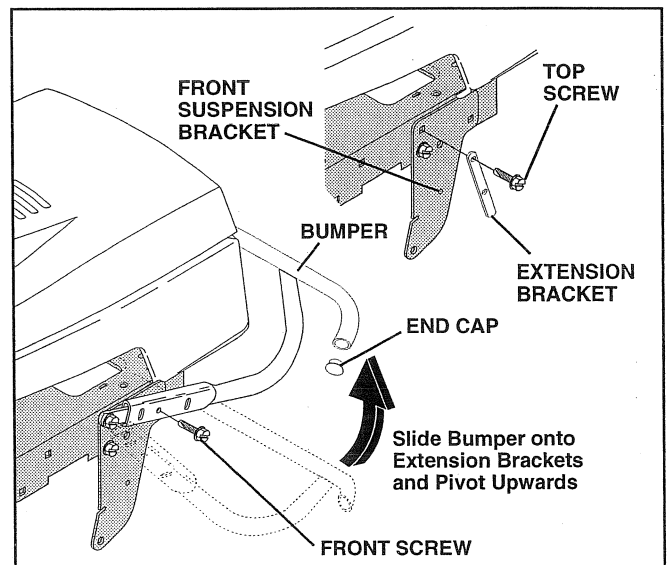

FIG. 5

# ASSEMBLY

## TO ATTACH NOSE ROLLER (See Fig. 6)

- Position brackets, 17/32 x 7/8 x 16 gauge washers, and nose roller between deck mounting brackets as shown. Be sure to position brackets on correct side, as shown.
- Install 3/8-16 x 1 hex bolts and 3/8-16 crownlock nuts as shown. Tighten hardware securely.

**NOTE:** Be sure bracket tabs are positioned in tab holes in deck brackets.

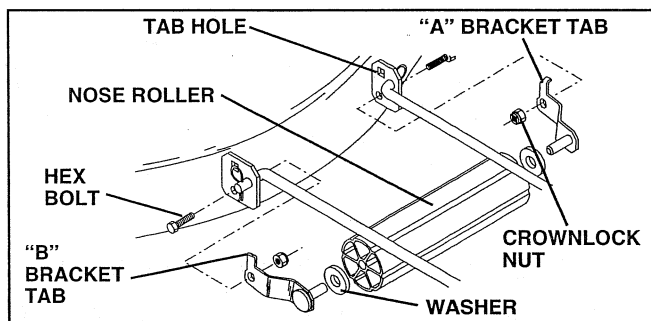

FIG. 6

## ASSEMBLE GAUGE WHEELS AND BRACKETS TO MOWER DECK (See Fig. 7)

The gauge wheels are designed to keep the mower deck in proper position when operating mower. Be sure they are properly adjusted to ensure optimum mower performance.

- Attach front gauge wheel brackets marked front left (FL), front right (FR) to mower deck using (3) carriage bolts and (3) locknuts. For ease of installation do not tighten locknuts until all carriage bolts have been installed.
- Attach rear gauge wheel brackets marked rear left (RL), rear right (RR) to mower deck using (3) carriage bolts and (3) locknuts. For ease of installation do not tighten locknuts until all carriage bolts have been installed.

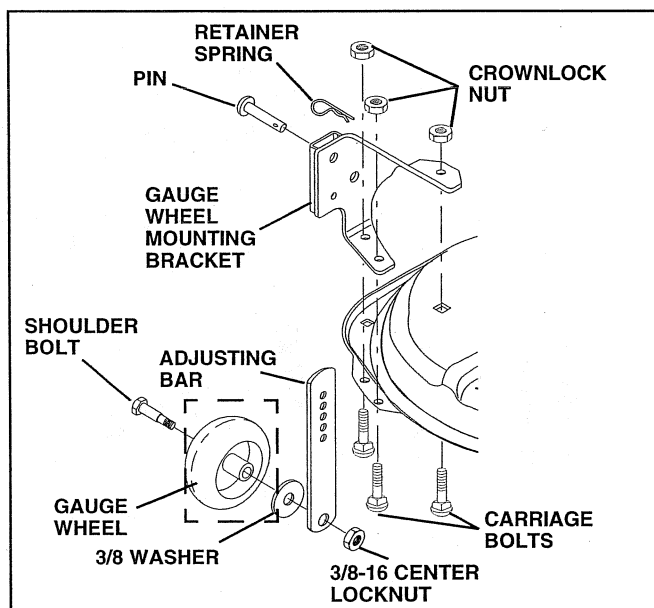

FIG. 7

- Slide gauge wheel bar down into bracket channel. Be sure that gauge wheel bar aligning holes are on top. Assemble gauge wheels as shown using shoulder bolts, 3/8 washers and 3/8-16 center locknuts and tighten securely.
- Adjust gauge wheels to highest position for ease of mower deck assembly.
- Adjust gauge wheels before operating mower as shown in the operation section of this manual.

## INSTALL MULCHER PLATE (See Figs. 8 and 9)

- Install two latch hooks to mulcher plate using screw, washer, lock washer, and weld nut as shown.

**NOTE:** Pre-assemble weld nut to latch hook by inserting weld nut from the top with hook pointing down.

- Tighten hardware securely.
- Raise and hold deflector shield in upright position.
- Place front of mulcher plate over front of mower deck opening and slide into place, as shown.
- Hook front latch into hole on front of mower deck.
- Hook rear latch into hole on back of mower deck.



**CAUTION:** Do not remove discharge guard from mower. Raise and hold guard when attaching mulcher plate and allow it to rest on plate while in operation.

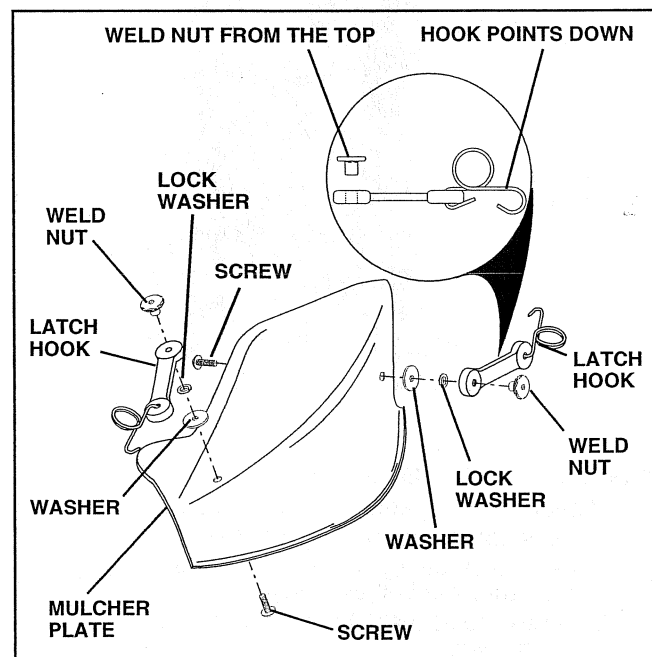

FIG. 8

# ASSEMBLY

## TO CONVERT TO BAGGING OR DISCHARGING

Simply remove mulcher plate and store in a safe place. Your mower is now ready for discharging or installation of optional grass catcher accessory.

**NOTE:** It is not necessary to change blades. The mulcher blades are designed for discharging and bagging also.

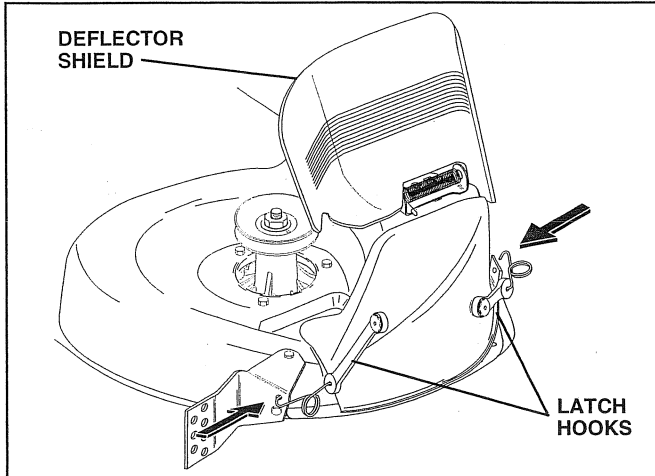

FIG. 9

## CHECK TIRE PRESSURE

The tires on your tractor were overinflated at the factory for shipping purposes. Correct tire pressure is important for best cutting performance.

- Reduce tire pressure to PSI shown in "PRODUCT SPECIFICATIONS" on page 3 of this manual.

## CHECK DECK LEVELNESS

For best cutting results, mower housing should be properly leveled. See "TO LEVEL MOWER HOUSING" in the Service and Adjustments section of this manual.

## CHECK FOR PROPER POSITION OF ALL BELTS

See the figures that are shown for replacing motion and mower blade drive belts in the Service and Adjustments section of this manual. Verify that the belts are routed correctly.

## CHECK BRAKE SYSTEM

After you learn how to operate your tractor, check to see that the brake is properly adjusted. See "TO ADJUST BRAKE" in the Service and Adjustments section of this manual.

## ✓ CHECKLIST

*BEFORE YOU OPERATE AND ENJOY YOUR NEW TRACTOR, WE WISH TO ASSURE THAT YOU RECEIVE THE BEST PERFORMANCE AND SATISFACTION FROM THIS QUALITY PRODUCT.*

*PLEASE REVIEW THE FOLLOWING CHECKLIST:*

- ✓ All assembly instructions have been completed.
- ✓ No remaining loose parts in carton.
- ✓ Battery is properly prepared and charged. (Minimum 1 hour at 6 amps).
- ✓ Seat is adjusted comfortably and tightened securely.
- ✓ All tires are properly inflated. (For shipping purposes, the tires were overinflated at the factory).
- ✓ Be sure mower deck is properly leveled side-to-side/front-to-rear for best cutting results. (Tires must be properly inflated for leveling).
- ✓ Check mower and drive belts. Be sure they are routed properly around pulleys and inside all belt keepers.
- ✓ Check wiring. See that all connections are still secure and wires are properly clamped.
- ✓ Before driving tractor, be sure freewheel control is in drive position.

*WHILE LEARNING HOW TO USE YOUR TRACTOR, PAY EXTRA ATTENTION TO THE FOLLOWING IMPORTANT ITEMS:*

- ✓ Engine oil is at proper level.
- ✓ Fuel tank is filled with fresh, clean, regular unleaded gasoline.
- ✓ Become familiar with all controls - their location and function. Operate them before you start the engine.
- ✓ Be sure brake system is in safe operating condition.
- ✓ It is important to purge the transmission before operating your tractor for the first time. Follow proper starting and transmission purging instructions (See "TO START ENGINE" and "PURGE TRANSMISSION" in the Operation section of this manual).

# OPERATION

These symbols may appear on your tractor or in literature supplied with the product. Learn and understand their meaning.

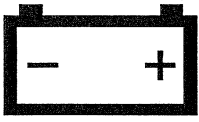

BATTERY



CAUTION OR WARNING



REVERSE



FORWARD



FAST



SLOW



ENGINE ON



ENGINE OFF

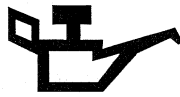

OIL PRESSURE



CLUTCH

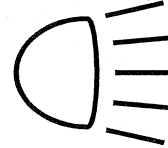

LIGHTS ON



OVER TEMP LIGHT



FUEL



CHOKE

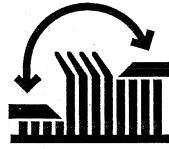

MOWER HEIGHT

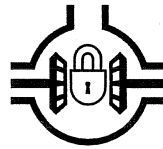

DIFFERENTIAL LOCK



PARKING BRAKE LOCKED



UNLOCKED



MOWER LIFT

R

REVERSE

N

NEUTRAL

H

HIGH

L

LOW

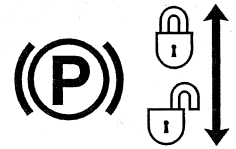

PARKING BRAKE



ATTACHMENT CLUTCH ENGAGED



ATTACHMENT CLUTCH DISENGAGED

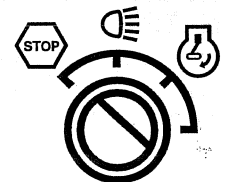

IGNITION



DANGER, KEEP HANDS AND FEET AWAY

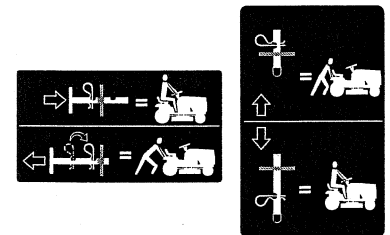

HYDROSTATIC FREE WHEEL (Hydro Models only)

# OPERATION

## KNOW YOUR TRACTOR

### READ THIS OWNER'S MANUAL AND SAFETY RULES BEFORE OPERATING YOUR TRACTOR

Compare the illustrations with your tractor to familiarize yourself with the locations of various controls and adjustments. Save this manual for future reference.

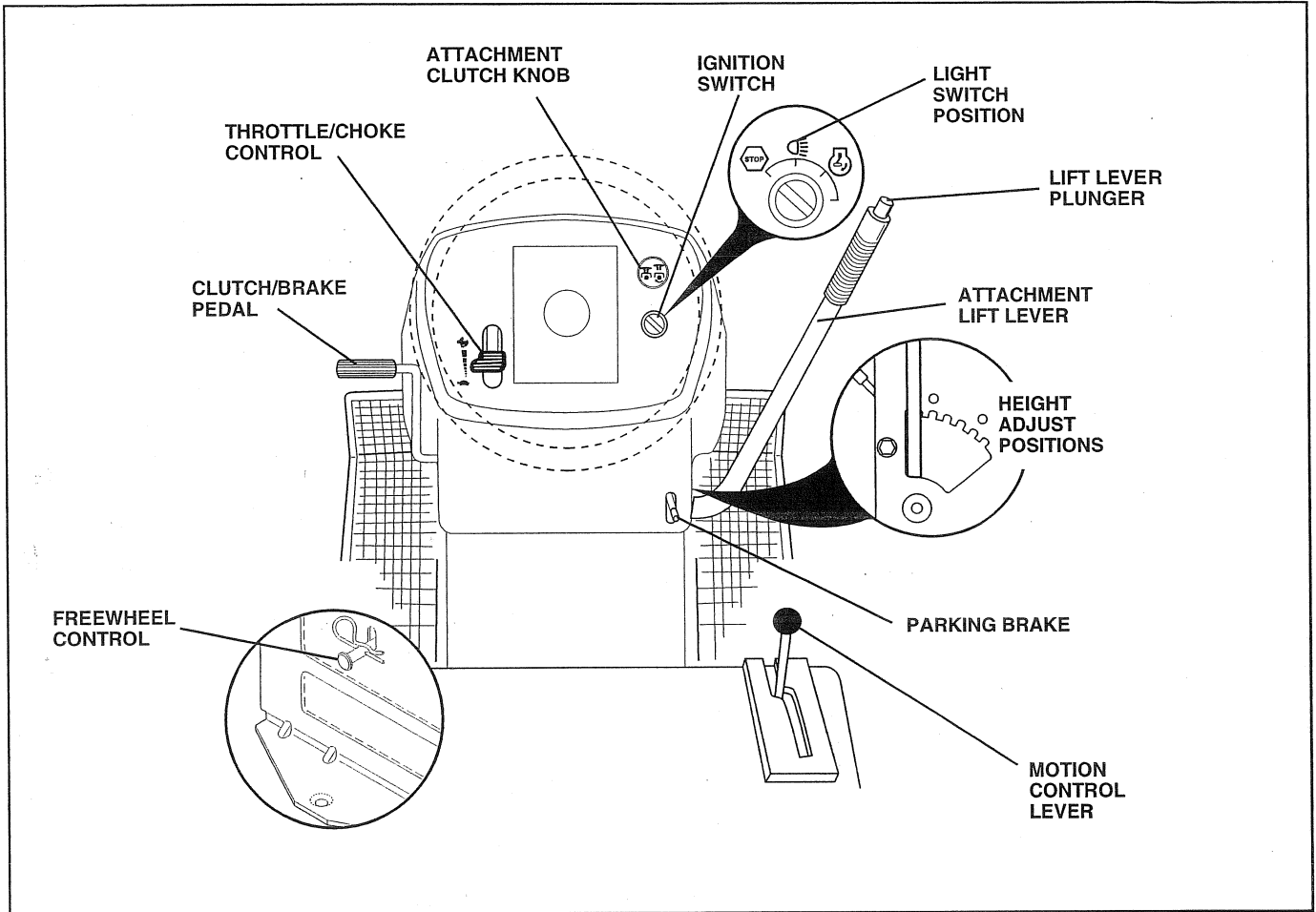

FIG. 10

Our tractors conform to the safety standards of the American National Standards Institute.

**ATTACHMENT CLUTCH KNOB** - Used to engage the mower blades, or other attachments mounted to your tractor.

**LIGHT SWITCH POSITION** - Turns the headlights on.

**THROTTLE/CHOKE CONTROL:** Used for starting and controlling engine speed.

**FREE WHEEL CONTROL** - Disengages transmission for pushing or slowly towing the tractor with the engine off.

**CLUTCH/BRAKE PEDAL** - Used for declutching and braking the tractor and starting the engine.

**PARKING BRAKE** - Locks clutch/brake pedal into the brake position.

**MOTION CONTROL LEVER** - Selects the speed and direction of tractor.

**ATTACHMENT LIFT LEVER** - Used to raise, lower, and adjust the mower deck or other attachments mounted to your tractor.

**LIFT LEVER PLUNGER** - Used to release attachment lift lever when changing its position.

**IGNITION SWITCH** - Used for starting and stopping the engine.

# OPERATION



The operation of any tractor can result in foreign objects thrown into the eyes, which can result in severe eye damage. Always wear safety glasses or eye shields while operating your tractor or performing any adjustments or repairs. We recommend a wide vision safety mask for over the spectacles or standard safety glasses.

## HOW TO USE YOUR TRACTOR TO SET PARKING BRAKE (See Fig. 11)

Your tractor is equipped with an operator presence sensing switch. When engine is running, any attempt by the operator to leave the seat without first setting the parking brake will shut off the engine.

- Depress clutch/brake pedal into full "BRAKE" position and hold.
- Place parking brake lever in "ENGAGED" position and release pressure from clutch/brake pedal. Pedal should remain in "BRAKE" position. Make sure parking brake will hold tractor secure.

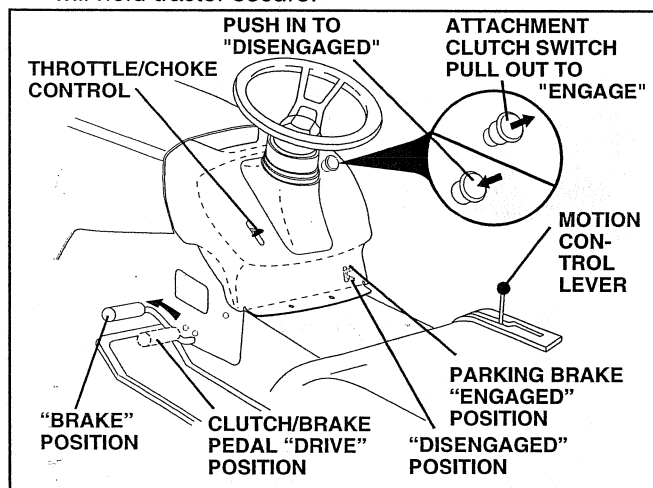

FIG. 11

## TO USE THROTTLE CONTROL (See Fig. 11)

Always operate engine at full throttle.

- Operating engine at less than full throttle reduces the battery charging rate.
- Full throttle offers the best bagging and mower performance.

## STOPPING (See Fig. 11)

MOWER BLADES -

- Move attachment clutch switch to "DISENGAGED" position.

GROUND DRIVE -

- Depress clutch/brake pedal into full "BRAKE" position.
- Move motion control lever to neutral (N) position.

**IMPORTANT: THE MOTION CONTROL LEVER DOES NOT RETURN TO NEUTRAL (N) POSITION WHEN THE CLUTCH/BRAKE PEDAL IS DEPRESSED.**

ENGINE -

- Move throttle control to slow position.

**NOTE:** Failure to move throttle control to slow position and allowing engine to idle before stopping may cause engine to "backfire".

- Turn ignition key to "OFF" position and remove key. Always remove key when leaving tractor to prevent unauthorized use.
- Never use choke to stop engine.

**NOTE:** Under certain conditions when tractor is standing idle with the engine running, hot engine exhaust gases may cause "browning" of grass. To eliminate this possibility, always stop engine when stopping tractor on grass areas.



**CAUTION:** Always stop tractor completely, as described above, before leaving the operator's position; to empty grass catcher, etc.

## TO MOVE FORWARD AND BACKWARD (See Fig. 11)

The direction and speed of movement is controlled by the motion control lever.

- Start tractor with motion control lever in neutral (N) position.
- Release parking brake and clutch/brake pedal.
- Slowly move motion control lever to desired position.

## TO ADJUST MOWER CUTTING HEIGHT (See Fig. 11)

The position of the attachment lift lever determines the cutting height.

- Grasp lift lever.
- Press plunger with thumb and move lever to desired position.

The cutting height range is approximately 1-1/2 to 4". The heights are measured from the ground to the blade tip with the engine not running. These heights are approximate and may vary depending upon soil conditions, height of grass and types of grass being mowed.

- The average lawn should be cut to approximately 2-1/2 inches during the cool season and to over 3 inches during hot months. For healthier and better looking lawns, mow often and after moderate growth.
- For best cutting performance, grass over 6 inches in height should be mowed twice. Make the first cut relatively high; the second to desired height.

## TO OPERATE MOWER (See Fig. 12)

Your tractor is equipped with an operator presence sensing switch. Any attempt by the operator to leave the seat with the engine running and the attachment clutch engaged will shut off the engine.

- Select desired height of cut.
- Start mower blades by engaging attachment clutch control.
- TO STOP MOWER BLADES - disengage attachment clutch control.



**CAUTION:** Do not operate the mower without either the entire grass catcher, on mowers so equipped, or the discharge guard in place.



# OPERATION

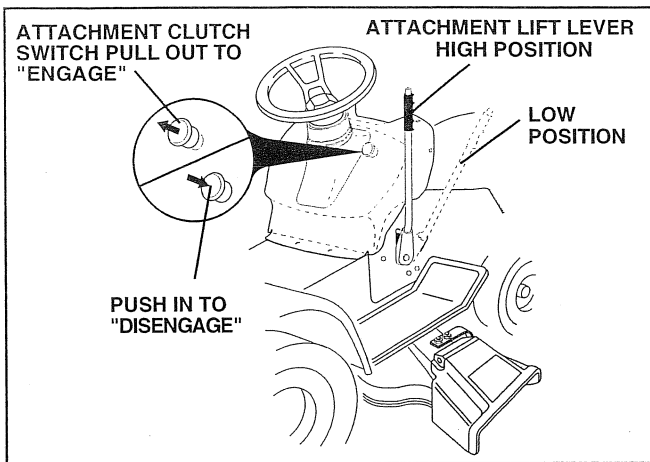

FIG. 12

## TO OPERATE ON HILLS



**CAUTION:** Do not drive up or down hills with slopes greater than 15° and do not drive across any slope.

- Choose the slowest speed before starting up or down hills.
- Avoid stopping or changing speed on hills.
- If slowing is necessary, move throttle control lever to slower position.
- If stopping is absolutely necessary, push clutch/brake pedal quickly to brake position and engage parking brake.
- Move motion control lever to neutral (N) position.

**IMPORTANT:** THE MOTION CONTROL LEVER DOES NOT RETURN TO NEUTRAL (N) POSITION WHEN THE CLUTCH/BRAKE PEDAL IS DEPRESSED.

- To restart movement, slowly release parking brake and clutch/brake pedal.
- Slowly move motion control lever to slowest setting.
- Make all turns slowly.

## TO TRANSPORT (See Figs. 10 and 13)

When pushing or towing your tractor, be sure to disengage transmission by placing freewheel control in freewheeling position. Free wheel control is located at the rear drawbar of tractor.

- Raise attachment lift to highest position with attachment lift control.
- Pull freewheel control knob out and hold in position by inserting retainer spring into forward hole of control rod.
- Do not push or tow tractor at more than two (2) MPH.
- To reengage transmission, reverse above procedure.

**NOTE:** To protect hood from damage when transporting your tractor on a truck or a trailer, be sure hood is closed and secured to tractor. Use an appropriate means of tying hood to tractor (rope, cord, etc.).

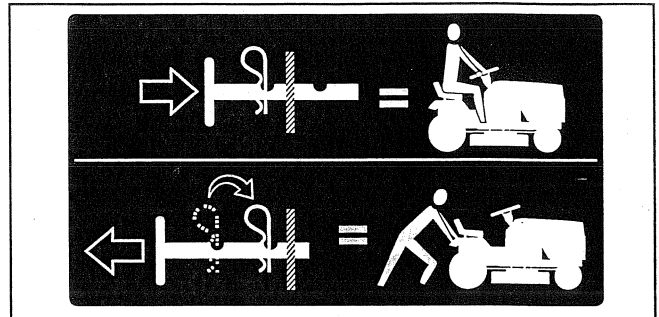

FIG. 13

## BEFORE STARTING THE ENGINE

### CHECK ENGINE OIL LEVEL (See Fig. 18)

- The engine in your tractor has been shipped, from the factory, already filled with summer weight oil.
- Check engine oil with tractor on level ground.
- Unthread and remove oil fill cap/dipstick; wipe oil off. Reinsert the dipstick into the tube and rest oil fill cap on the tube. Do not thread the cap onto the tube. Remove and read oil level. If necessary, add oil until "FULL" mark on dipstick is reached. Do not overfill.
- For cold weather operation you should change oil for easier starting (See "OIL VISCOSITY CHART" in the Customer Responsibilities section of this manual).
- To change engine oil, see the Customer Responsibilities section in this manual.

### ADD GASOLINE

- Fill fuel tank. Use fresh, clean, regular unleaded gasoline with a minimum of 87 octane. (Use of leaded gasoline will increase carbon and lead oxide deposits and reduce valve life). Do not mix oil with gasoline. Purchase fuel in quantities that can be used within 30 days to assure fuel freshness.

**IMPORTANT:** WHEN OPERATING IN TEMPERATURES BELOW 32°F(0°C), USE FRESH, CLEAN WINTER GRADE GASOLINE TO HELP INSURE GOOD COLD WEATHER STARTING.

**WARNING:** Experience indicates that alcohol blended fuels (called gasohol or using ethanol or methanol) can attract moisture which leads to separation and formation of acids during storage. Acidic gas can damage the fuel system of an engine while in storage. To avoid engine problems, the fuel system should be emptied before storage of 30 days or longer. Drain the gas tank, start the engine and let it run until the fuel lines and carburetor are empty. Use fresh fuel next season. See Storage Instructions for additional information. Never use engine or carburetor cleaner products in the fuel tank or permanent damage may occur.



**CAUTION:** Fill to bottom of gas tank filler neck. Do not overfill. Wipe off any spilled oil or fuel. Do not store, spill or use gasoline near an open flame.

# OPERATION

## TO START ENGINE (See Fig. 11)

When starting the engine for the first time or if the engine has run out of fuel, it will take extra cranking time to move fuel from the tank to the engine.

- Be sure freewheel control is in the transmission engaged position.
- Sit on seat in operating position, depress clutch/brake pedal and set parking brake.
- Place motion control lever in neutral (N) position.
- Move attachment clutch to "DISENGAGED" position.
- Move throttle control to choke position.

**Note:** Before starting, read the warm and cold starting procedures below.

- Insert key into ignition and turn key clockwise to "START" position and release key as soon as engine starts. Do not run starter continuously for more than fifteen seconds per minute. If the engine does not start after several attempts, move throttle control to fast position, wait a few minutes and try again. If engine still does not start, move the throttle control back to the choke position and retry.

### WARM WEATHER STARTING (50° F and above)

- When engine starts, move the throttle control to the fast position.
- The attachments and ground drive can now be used. If the engine does not accept the load, restart the engine and allow it to warm up for one minute using the choke as described above.

### COLD WEATHER STARTING ( 50° F and below)

- When engine starts, allow engine to run with the throttle control in the choke position until the engine runs roughly, then move throttle control to fast position. This may require an engine warm-up period from several seconds to several minutes, depending on the temperature.

### HYDROSTATIC TRANSMISSION WARM UP

- Before driving the unit in cold weather, the transmission should be warmed up as follows:
  - Be sure the tractor is on level ground.
  - Place the motion control lever in neutral. Release the parking brake and let the clutch/brake slowly return to operating position.
  - Allow one minute for transmission to warm up. This can be done during the engine warm up period.
- The attachments can also be used during the engine warm-up period after the transmission has been warmed up.

**NOTE:** If at a high altitude (above 3000 feet) or in cold temperatures (below 32 F) the carburetor fuel mixture may need to be adjusted for best engine performance. See "TO ADJUST CARBURETOR" in the Service and Adjustments section of this manual.

## PURGE TRANSMISSION



**CAUTION:** Never engage or disengage freewheel lever while the engine is running.

To ensure proper operation and performance, it is recommended that the transmission be purged before operating tractor for the first time. This procedure will remove any trapped air inside the transmission which may have developed during shipping of your tractor.

**IMPORTANT:** SHOULD YOUR TRANSMISSION REQUIRE REMOVAL FOR SERVICE OR REPLACEMENT, IT SHOULD BE PURGED AFTER REINSTALLATION BEFORE OPERATING THE TRACTOR.

- Place tractor safely on level surface with engine off and parking brake set.
- Disengage transmission by placing freewheel control in freewheeling position (See "TO TRANSPORT" in this section of manual).
- Sitting in the tractor seat, start engine. After the engine is running, move throttle control to slow position. With motion control lever in neutral (N) position, slowly disengage clutch/brake pedal.
- Move motion control lever to full forward position and hold for five (5) seconds. Move lever to full reverse position and hold for five (5) seconds. Repeat this procedure three (3) times.

**NOTE:** During this procedure there will be no movement of drive wheels. The air is being removed from hydraulic drive system.

- Move motion control lever to neutral (N) position. Shut-off engine and set parking brake.
- Engage transmission by placing freewheel control in driving position (See "TO TRANSPORT" in this section of manual).
- Sitting in the tractor seat, start engine. After the engine is running, move throttle control to half (1/2) speed. With motion control lever in neutral (N) position, slowly disengage clutch/brake pedal.
- Slowly move motion control lever forward, after the tractor moves approximately five (5) feet, slowly move motion control lever to reverse position. After the tractor moves approximately five (5) feet return the motion control lever to the neutral (N) position. Repeat this procedure with the motion control lever three (3) times.
- Your tractor is now purged and now ready for normal operation.

# OPERATION

## MOWING TIPS

- Tire chains cannot be used when the mower housing is attached to tractor.
- Mower should be properly leveled for best mowing performance. See "TO LEVEL MOWER HOUSING" in the Service and Adjustments section of this manual.
- The left hand side of mower should be used for trimming.
- Drive so that clippings are discharged onto the area that has been cut. Have the cut area to the right of the machine. This will result in a more even distribution of clippings and more uniform cutting.
- When mowing large areas, start by turning to the right so that clippings will discharge away from shrubs, fences, driveways, etc. After one or two rounds, mow in the opposite direction making left hand turns until finished (See Fig. 14).
- If grass is extremely tall, it should be mowed twice to reduce load and possible fire hazard from dried clippings. Make first cut relatively high; the second to the desired height.
- Do not mow grass when it is wet. Wet grass will plug mower and leave undesirable clumps. Allow grass to dry before mowing.
- Always operate engine at full throttle when mowing to assure better mowing performance and proper discharge of material. Regulate ground speed by selecting a low enough gear to give the mower cutting performance as well as the quality of cut desired.
- When operating attachments, select a ground speed that will suit the terrain and give best performance of the attachment being used.

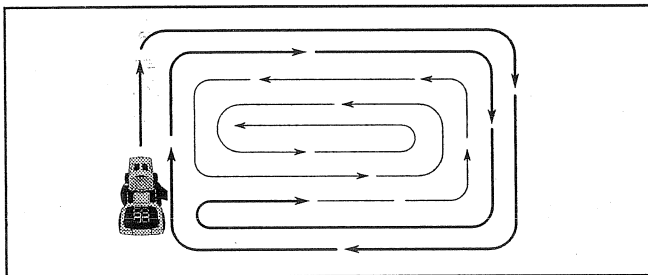

FIG. 14

## MULCHING MOWING TIPS

**IMPORTANT: FOR BEST PERFORMANCE, KEEP MOWER HOUSING FREE OF BUILT-UP GRASS AND TRASH. CLEAN AFTER EACH USE.**

- The special mulching blade will recut the grass clippings many times and reduce them in size so that as they fall onto the lawn they will disperse into the grass and not be noticed. Also, the mulched grass will biodegrade quickly to provide nutrients for the lawn. Always mulch with your highest engine (blade) speed as this will provide the best recutting action of the blades.
- Avoid cutting your lawn when it is wet. Wet grass tends to form clumps and interferes with the mulching action. The best time to mow your lawn is the early afternoon. At this time the grass has dried and the newly cut area will not be exposed to the direct sun.
- For best results, adjust the mower cutting height so that the mower cuts off only the top one-third of the grass blades (See Fig. 15). For extremely heavy mulching, reduce your width of cut and mow slowly.
- Certain types of grass and grass conditions may require that an area be mulched a second time to completely hide the clippings. When doing a second cut, mow across or perpendicular to the first cut path.
- Change your cutting pattern from week to week. Mow north to south one week then change to east to west the next week. This will help prevent matting and graining of the lawn.

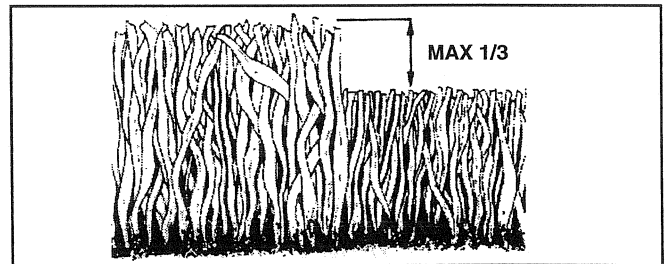

FIG. 15

# CUSTOMER RESPONSIBILITIES

MAINTENANCE SCHEDULE FILL IN DATES AS YOU COMPLETE REGULAR SERVICE		SERVICE DATES																
		BEFORE EACH USE	EVERY 8 HOURS	EVERY 25 HOURS	EVERY 50 HOURS	EVERY 100 HOURS	EVERY SEASON	BEFORE STORAGE										
TRACTOR	Check Brake Operation	✓	✓															
	Check Tire Pressure	✓	✓															
	Check for Loose Fasteners	✓					✓ <sub>7</sub>		✓									
	Sharpen/Replace Mower Blades			✓ <sub>4</sub>														
	Lubrication Chart			✓					✓									
	Check Battery Level/Recharge			✓ <sub>6</sub>														
	Clean Battery and Terminals			✓					✓									
	Check Transaxle Cooling			✓														
	Adjust Blade Belt(s) Tension						✓ <sub>5</sub>											
	Adjust Motion Drive Belt(s) Tension						✓ <sub>5</sub>											
ENGINE	Check Engine Oil Level	✓	✓															
	Change Engine Oil			✓ <sub>1,2,3</sub>					✓									
	Clean Air Filter			✓ <sub>2</sub>														
	Clean Air Screen			✓ <sub>2</sub>														
	Inspect Muffler/Spark Arrester				✓													
	Replace Oil Filter (If equipped)						✓ <sub>1,2</sub>											
	Clean Engine Cooling Fins						✓ <sub>2</sub>											
	Replace Spark Plug						✓		✓									
	Replace Air Filter Paper Cartridge						✓ <sub>2</sub>											
	Replace Fuel Filter								✓									

- 1 - Change more often when operating under a heavy load or in high ambient temperatures.
- 2 - Service more often when operating in dirty or dusty conditions.
- 3 - If equipped with oil filter, change oil every 50 hours.
- 4 - Replace blades more often when mowing in sandy soil.

- 5 - If equipped with adjustable system.  
Do not overtighten.
- 6 - Not required if equipped with maintenance-free battery.
- 7 - Tighten front axle pivot bolt to 35 ft.-lbs. maximum.

## GENERAL RECOMMENDATIONS

The warranty on this tractor does not cover items that have been subjected to operator abuse or negligence. To receive full value from the warranty, operator must maintain tractor as instructed in this manual.

Some adjustments will need to be made periodically to properly maintain your tractor.

All adjustments in the Service and Adjustments section of this manual should be checked at least once each season.

- Once a year you should replace the spark plug, clean or replace air filter, and check blades and belts for wear. A new spark plug and clean air filter assure proper air-fuel mixture and help your engine run better and last longer.

## BEFORE EACH USE

- Check engine oil level.
- Check brake operation.
- Check tire pressure.
- Check for loose fasteners.

## LUBRICATION CHART

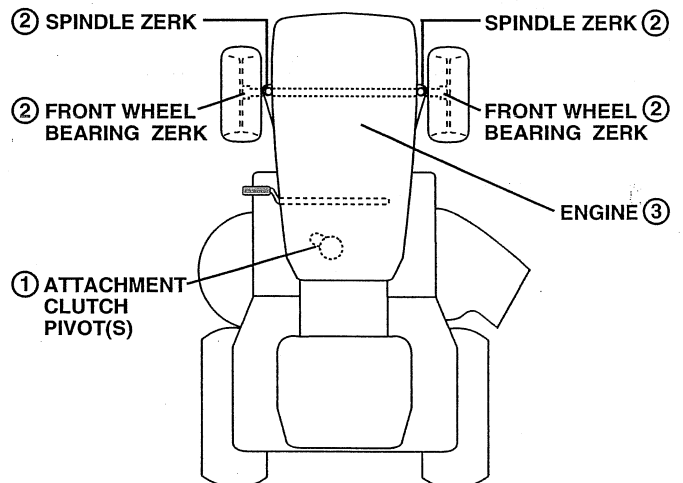

① SAE 30 OR 10W30 MOTOR OIL

② GENERAL PURPOSE GREASE

③ REFER TO CUSTOMER RESPONSIBILITIES "ENGINE" SECTION

**IMPORTANT:** DO NOT OIL OR GREASE THE PIVOT POINTS WHICH HAVE SPECIAL NYLON BEARINGS. VISCOUS LUBRICANTS WILL ATTRACT DUST AND DIRT THAT WILL SHORTEN THE LIFE OF THE SELF-LUBRICATING BEARINGS. IF YOU FEEL THEY MUST BE LUBRICATED, USE ONLY A DRY, POWDERED GRAPHITE TYPE LUBRICANT SPARINGLY.

# CUSTOMER RESPONSIBILITIES

## TRACTOR

Always observe safety rules when performing any maintenance.

## BRAKE OPERATION

If tractor requires more than six (6) feet stopping distance at high speed in highest gear, then brake must be adjusted. (See "TO ADJUST BRAKE" in the Service and Adjustments section of this manual).

## TIRES

- Maintain proper air pressure in all tires (See "PRODUCT SPECIFICATIONS" on page 3 of this manual).
- Keep tires free of gasoline, oil, or insect control chemicals which can harm rubber.
- Avoid stumps, stones, deep ruts, sharp objects and other hazards that may cause tire damage.

**NOTE:** To seal tire punctures and prevent flat tires due to slow leaks, tire sealant may be purchased from your local parts dealer. Tire sealant also prevents tire dry rot and corrosion.

## BLADE CARE

For best results mower blades must be kept sharp. Replace bent or damaged blades.

## BLADE REMOVAL (See Fig. 16)

- Raise mower to highest position to allow access to blades.
- Remove hex bolt, lock washer and flat washer securing blade.
- Install new or resharpened blade with trailing edge up towards deck as shown.
- Reassemble hex bolt, lock washer and flat washer in exact order as shown.
- Tighten bolt securely (30-35 Ft. Lbs. torque).

**IMPORTANT:** BLADE BOLT IS GRADE 8 HEAT TREATED.

**NOTE:** We do not recommend sharpening blade - but if you do, be sure the blade is balanced.

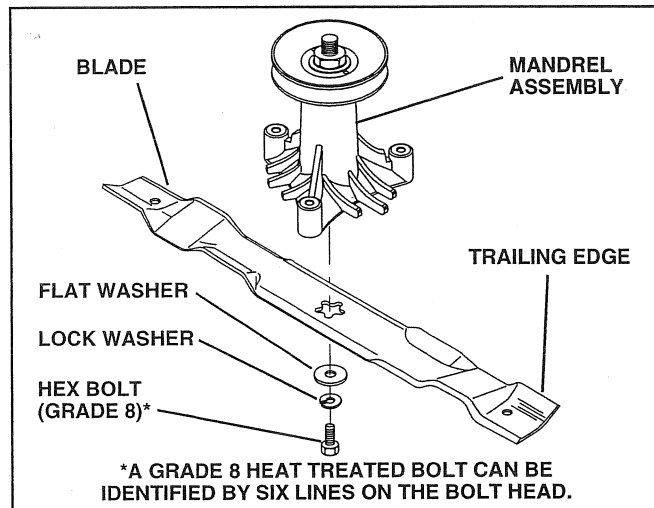

FIG. 16

## TO SHARPEN BLADE (See Fig. 17)

Care should be taken to keep the blade balanced. An unbalanced blade will cause excessive vibration and eventual damage to mower and engine.

- The blade can be sharpened with a file or on a grinding wheel. Do not attempt to sharpen while on the mower.

- To check blade balance, you will need a 5/8" diameter steel bolt, pin, or a cone balancer. (When using a cone balancer, follow the instructions supplied with balancer).
- Slide blade on to an unthreaded portion of the steel bolt or pin and hold the bolt or pin parallel with the ground. If blade is balanced, it should remain in a horizontal position. If either end of the blade moves downward, sharpen the heavy end until the blade is balanced.

**NOTE:** Do not use a nail for balancing blade. The lobes of the center hole may appear to be centered, but are not.

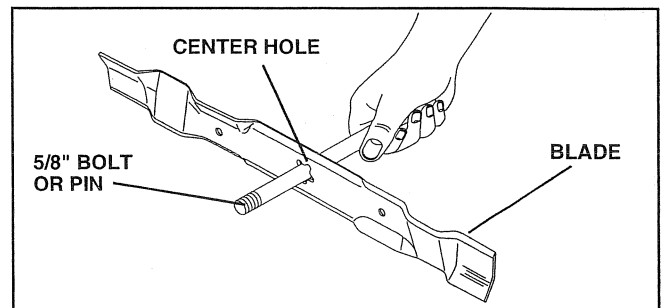

FIG. 17

## BATTERY

Your tractor has a battery charging system which is sufficient for normal use. However, periodic charging of the battery with an automotive charger will extend its life.

- Keep battery and terminals clean.
- Keep battery bolts tight.
- Keep small vent holes open.
- Recharge at 6-10 amperes for 1 hour.

## TO CLEAN BATTERY AND TERMINALS

Corrosion and dirt on the battery and terminals can cause the battery to "leak" power.

- Open battery box door.
- Disconnect BLACK battery cable first then RED battery cable and remove battery from tractor.
- Rinse the battery with plain water and dry.
- Clean terminals and battery cable ends with wire brush until bright.
- Coat terminals with grease or petroleum jelly.
- Reinstall battery (See "CONNECT BATTERY" in the Assembly section of this manual).

## V-BELTS

Check V-belts for deterioration and wear after 100 hours of operation and replace if necessary. The belts are not adjustable. Replace belts if they begin to slip from wear.

## TRANSAXLE COOLING

The fan and cooling fins of transmission should be kept clean to assure proper cooling.

Do not attempt to clean fan or transmission while engine is running or while the transmission is hot.

- Inspect cooling fan to be sure fan blades are intact and clean.
- Inspect cooling fins for dirt, grass clippings and other materials. To prevent damage to seals, do not use compressed air or high pressure sprayer to clean cooling fins.

## TRANSAXLE PUMP FLUID

The transaxle was sealed at the factory and fluid maintenance is not required for the life of the transaxle. Should the transaxle ever leak or require servicing, contact your nearest authorized service center/department.

# CUSTOMER RESPONSIBILITIES

## ENGINE

### LUBRICATION

Only use high quality detergent oil rated with API service classification SF, SG, or SH. Select the oil's SAE viscosity grade according to your expected operating temperature.

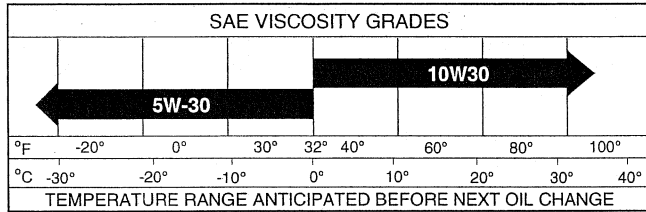

Change the oil after every 50 hours of operation or at least once a year if the tractor is not used for 50 hours in one year.

Check the crankcase oil level before starting the engine and after each eight (8) hours of operation. Tighten oil fill cap/dipstick securely each time you check the oil level.

#### TO CHANGE ENGINE OIL (See Fig. 18)

Determine temperature range expected before oil change. All oil must meet API service classification SF, SG, or SH.

- Be sure tractor is on level surface.
- Oil will drain more freely when warm.
- Catch oil in a suitable container.
- Remove oil fill cap/dipstick. Be careful not to allow dirt to enter the engine when changing oil.
- Remove drain plug.
- After oil has drained completely, replace oil drain plug and tighten securely.
- Refill engine with oil through oil fill dipstick tube. Pour slowly. Do not overfill. For approximate capacity see "PRODUCT SPECIFICATIONS" on page 3 of this manual.
- Use gauge on oil fill cap/dipstick for checking level. Insert dipstick into the tube and rest the oil fill cap on the tube. Do not thread the cap onto the tube when taking reading. Keep oil at "FULL" line on dipstick. Tighten cap onto the tube securely when finished.

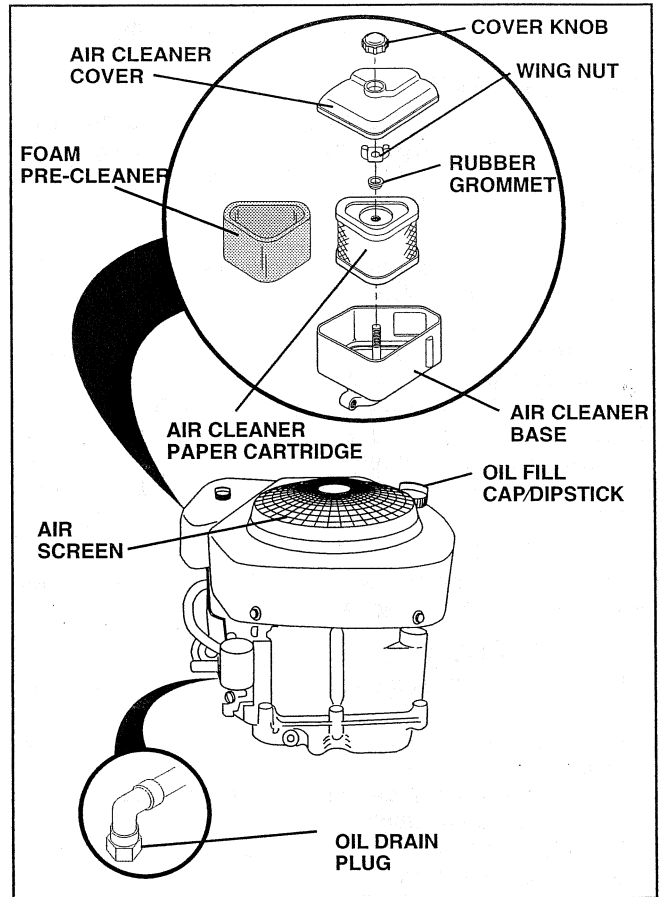

FIG. 18

#### AIR FILTER (See Fig. 18)

Your engine will not run properly using a dirty air filter. Clean the foam pre-cleaner after every 25 hours of operation or every season. Service paper cartridge every 100 hours of operation or every season, whichever occurs first.

Service air cleaner more often under dusty conditions.

- Remove knob and cover.
- Remove wing nut and air cleaner from base.

#### TO SERVICE PRE-CLEANER

- Slide foam pre-cleaner off cartridge.
- Wash it in liquid detergent and water.
- Squeeze it dry in a clean cloth. Allow it to dry.
- Saturate it in engine oil. Wrap it in clean, absorbent cloth and squeeze to remove excess oil.

#### TO SERVICE CARTRIDGE

- Replace a dirty, bent, or damaged cartridge.

**NOTE:** Do not wash the paper cartridge or use pressurized air, as this will damage the cartridge.

- Reinstall the pre-cleaner (cleaned and oiled) over the paper cartridge.
- Reassemble air cleaner, wing nut, cover and tighten knob securely.

# CUSTOMER RESPONSIBILITIES

## CLEAN AIR SCREEN (See Fig. 18)

Air screen must be kept free of dirt and chaff to prevent engine damage from overheating. Clean with a wire brush or compressed air to remove dirt and stubborn dried gum fibers.

## CLEAN AIR INTAKE/COOLING AREAS

To insure proper cooling, make sure the grass screen, cooling fins, and other external surfaces of the engine are kept clean at all times.

Every 100 hours of operation (more often under extremely dusty, dirty conditions), remove the blower housing and other cooling shrouds. Clean the cooling fins and external surfaces as necessary. Make sure the cooling shrouds are reinstalled.

**NOTE:** Operating the engine with a blocked grass screen, dirty or plugged cooling fins, and/or cooling shrouds removed will cause engine damage due to overheating.

## MUFFLER

Inspect and replace corroded muffler and spark arrester (if equipped) as it could create a fire hazard and/or damage.

## SPARK PLUGS

Replace spark plugs at the beginning of each mowing season or after every 100 hours of operation, whichever occurs first. Spark plug type and gap setting are shown in "PRODUCT SPECIFICATIONS" on page 3 of this manual.

## ENGINE OIL FILTER (See Fig. 19)

Replace the engine oil filter every season or every other oil change if the tractor is used more than 100 hours in one year.

- Drain oil from engine crankcase (See "TO CHANGE ENGINE OIL" in this section of this manual, through step remove drain plug).
- Remove oil filter and wipe off filter adapter.
- Apply a thin coating of new engine oil to the rubber gasket on replacement oil filter.
- Install replacement oil filter on filter adapter. Turn oil filter clockwise until rubber gasket contacts the filter adapter, then tighten filter an additional 1/2 turn.
- Fill crankcase with new oil (See "TO CHANGE ENGINE OIL" in this section of this manual). For approximate capacity see "PRODUCT SPECIFICATIONS" on page 3 of this manual.
- Start the engine and check for oil leaks. Correct any leaks before placing engine into full operation.

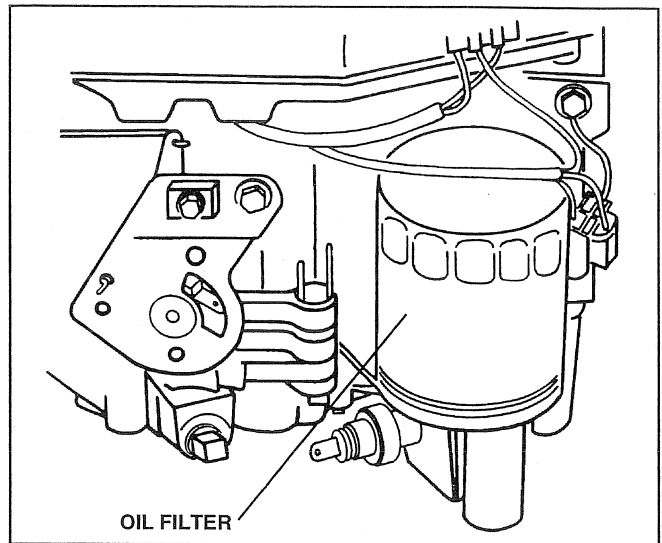

FIG. 19

## IN-LINE FUEL FILTER (See Fig. 20)

The fuel filter should be replaced once each season. If fuel filter becomes clogged, obstructing fuel flow to carburetor, replacement is required.

- With engine cool, remove filter and plug fuel line sections.
- Place new fuel filter in position in fuel line with arrow pointing towards carburetor.
- Be sure there are no fuel line leaks and clamps are properly positioned.
- Immediately wipe up any spilled gasoline.

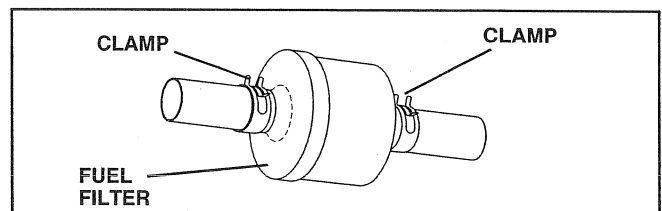

FIG. 20

## CLEANING

- Clean engine, battery, seat, finish, etc. of all foreign matter.
- Keep finished surfaces and wheels free of all gasoline, oil, etc.
- Protect painted surfaces with automotive type wax.

We do not recommend using a garden hose to clean your tractor unless the electrical system, muffler, air filter and carburetor are covered to keep water out. Water in engine can result in a shortened engine life.

# SERVICE AND ADJUSTMENTS



## CAUTION: BEFORE PERFORMING ANY SERVICE OR ADJUSTMENTS:

- Depress clutch/brake pedal fully and set parking brake.
- Place motion control lever in neutral (N) position.
- Place attachment clutch in "DISENGAGED" position.
- Turn ignition key "OFF" and remove key.
- Make sure the blades and all moving parts have completely stopped.
- Disconnect spark plug wire from spark plug and place wire where it cannot come in contact with plug.

## TRACTOR

### TO REMOVE MOWER (See Fig. 21)

Mower will be easier to remove from the right side of tractor.

- Place attachment clutch switch in "DISENGAGED" position.
- Move attachment lift lever forward to lower mower to its lowest position.
- Roll belt off electric clutch pulley.
- Disconnect anti-sway bar from chassis bracket by removing retainer spring.
- Disconnect suspension arms from rear deck brackets by removing retainer springs.
- Disconnect front links from deck by removing retainer springs.
- Raise lift lever to raise suspension arms. Slide mower out from under tractor.

**IMPORTANT:** IF AN ATTACHMENT OTHER THAN THE MOWER DECK IS TO BE MOUNTED ON THE TRACTOR, REMOVE THE FRONT LINKS.

### TO INSTALL MOWER (See Fig. 22)

- Raise attachment lift lever to its highest position.
- Slide mower under tractor with discharge guard to right side of tractor.
- Lower lift lever to its lowest position.
- Install mower in reverse order of removal instructions.

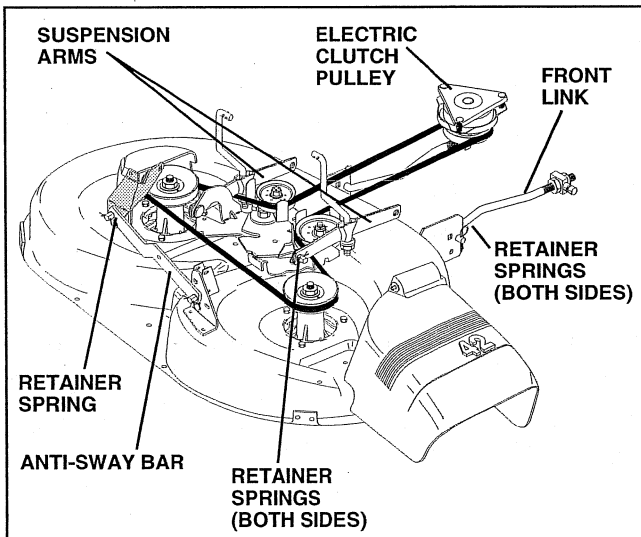

FIG. 21

## TO LEVEL MOWER HOUSING

Adjust the mower while tractor is parked on level ground or driveway. Make sure tires are properly inflated (See "PRODUCT SPECIFICATIONS" on page 3 of this manual). If tires are over or underinflated, you will not properly adjust your mower.

### SIDE-TO-SIDE ADJUSTMENT (See Figs. 22 and 23)

- Raise mower to its highest position.
- At the midpoint of both sides of mower, measure height from bottom edge of mower to ground. Distance "A" on both sides of mower should be the same or within 1/4" of each other.
- If adjustment is necessary, make adjustment on one side of mower only.
- To raise one side of mower, tighten lift link adjustment nut on that side.
- To lower one side of mower, loosen lift link adjustment nut on that side.

**NOTE:** Three full turns of adjustment nut will change mower height about 1/8".

- Recheck measurements after adjusting.

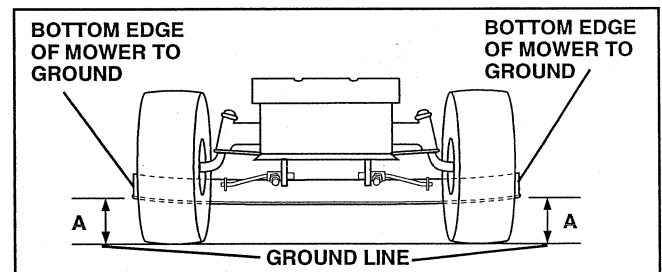

FIG. 22

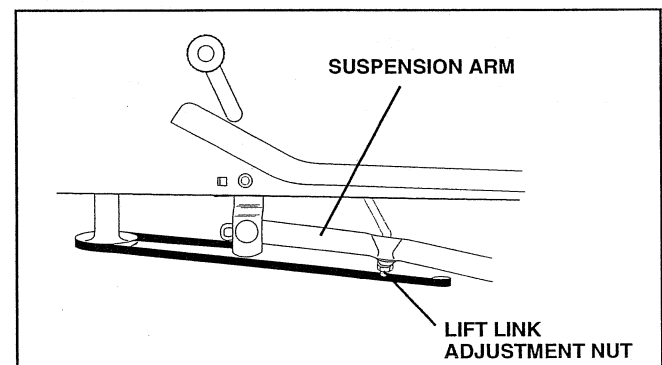

FIG. 23



# SERVICE AND ADJUSTMENTS

FRONT-TO-BACK ADJUSTMENT (See Figs. 24 and 25)  
**IMPORTANT:** DECK MUST BE LEVEL SIDE-TO-SIDE. IF THE FOLLOWING FRONT-TO-BACK ADJUSTMENT IS NECESSARY, BE SURE TO ADJUST BOTH FRONT LINKS EQUALLY SO MOWER WILL STAY LEVEL SIDE-TO-SIDE.

To obtain the best cutting results, the mower housing should be adjusted so that the front is approximately 1/8" to 1/2" lower than the rear when the mower is in its highest position.

Check adjustment on right side of tractor. Measure distance "D" directly in front and behind the mandrel at bottom edge of mower housing as shown.

- Before making any necessary adjustments, check that both front links are equal in length. Both links should be approximately 10-3/8".
- If links are not equal in length, adjust one link to same length as other link.
- To lower front of mower loosen nut "E" on both front links an equal number of turns.
- When distance "D" is 1/8" to 1/2" lower at front than rear, tighten nuts "F" against trunnion on both front links.
- To raise front of mower, loosen nut "F" from trunnion on both front links. Tighten nut "E" on both front links an equal number of turns.
- When distance "D" is 1/8" to 1/2" lower at front than rear, tighten nut "F" against trunnion on both front links.
- Recheck side-to-side adjustment.

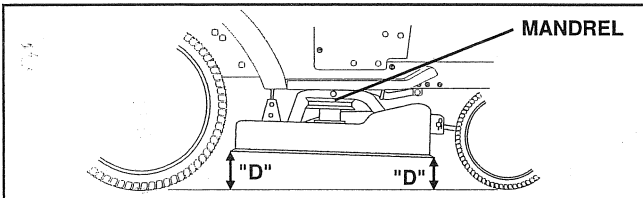

FIG. 24

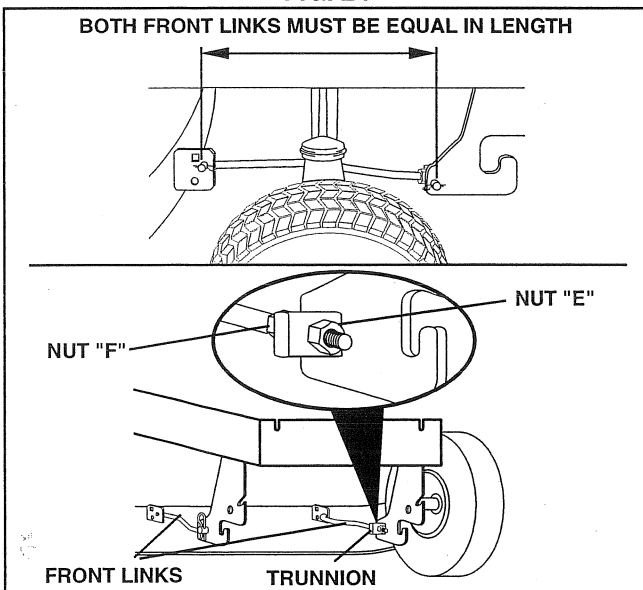

FIG. 25

## TO REPLACE MOWER BLADE DRIVE BELT (See Fig. 26)

The mower blade drive belt may be replaced without tools. Park the tractor on level surface. Engage parking brake.

### BELT REMOVAL -

- Remove mower from tractor (See "TO REMOVE MOWER" in this section of this manual).
- Work belt off both mandrel pulleys and idler pulleys.
- Pull belt away from mower.

### BELT INSTALLATION -

- Install new belt in reverse order of removal.
- Make sure belt is in all pulley grooves and inside all belt guides.
- Install mower in reverse order of removal instructions.

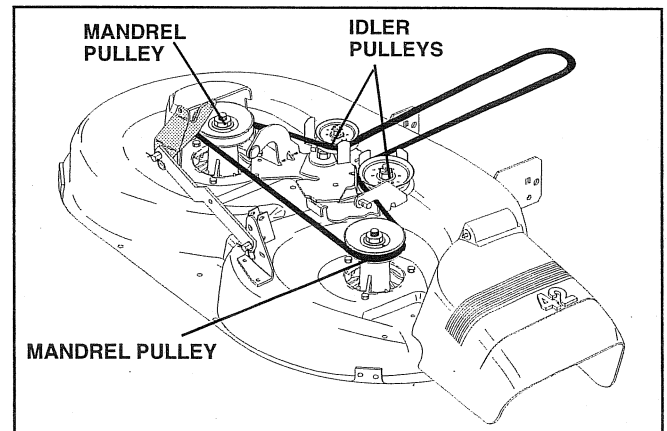

FIG. 26

## TO ADJUST BRAKE (See Fig. 27A)

Your tractor is equipped with an adjustable brake system which is mounted on the side of the transaxle.

If tractor requires more than six (6) feet stopping distance at high speed in highest gear, then brake must be adjusted.

- Depress clutch/brake pedal and engage parking brake.
- Measure distance between brake operating arm and nut "A" on brake rod.
- If distance is other than 1-3/4", loosen jam nut and turn nut "A" until distance becomes 1-3/4". Retighten jam nut against nut "A".

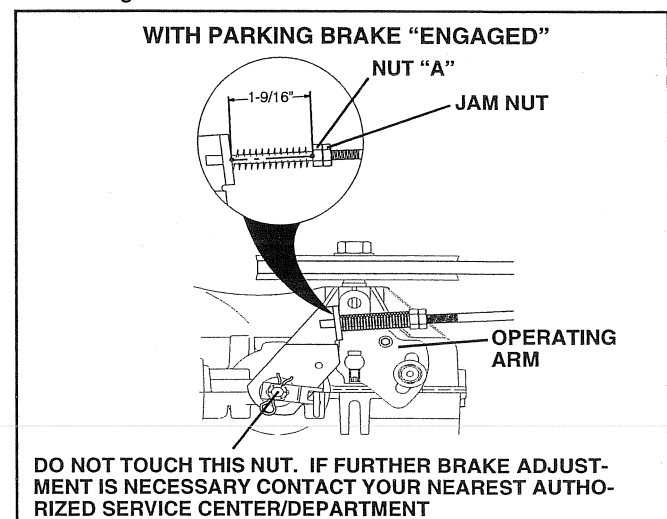

FIG. 27A

# SERVICE AND ADJUSTMENTS

- Road test tractor for proper stopping distance as stated above. Readjust if necessary. If stopping distance is still greater than six (6) feet in highest gear, further maintenance is necessary. Contact your nearest authorized service center/department.

## TO ADJUST ATTACHMENT CLUTCH

(See Fig. 27B)

The electric clutch should provide years of service. The clutch has a built-in brake that stops the pulley within 5 seconds. Eventually, the internal brake will wear which may cause the mower blades to not engage, or, to not stop as required. Adjustments should be made by your nearest authorized service center/department.

- Make sure attachment clutch and ignition switches are in "OFF" position.
- Adjust the three nylon locknuts until space between clutch plate and rotor measures .012" at all three slot locations cut in the side of brake plate.

**NOTE:** After installing a new electric clutch, run tractor at full throttle and engage and disengage electric clutch 10 cycles to wear in clutch plate.

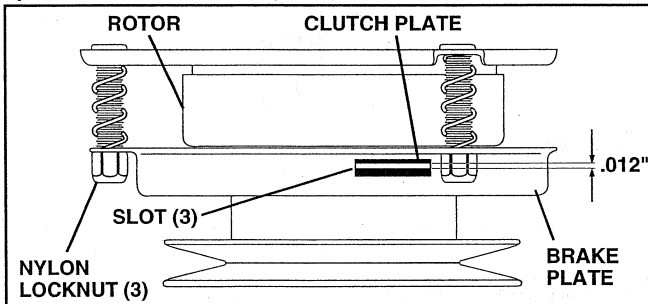

FIG. 27B

## TO REPLACE MOTION DRIVE BELT

(See Fig. 28)

Park the tractor on level surface. Engage parking brake. For assistance, there is a belt installation guide decal on bottom side of left footrest.

- Remove mower (See "TO REMOVE MOWER" in this section of this manual.)

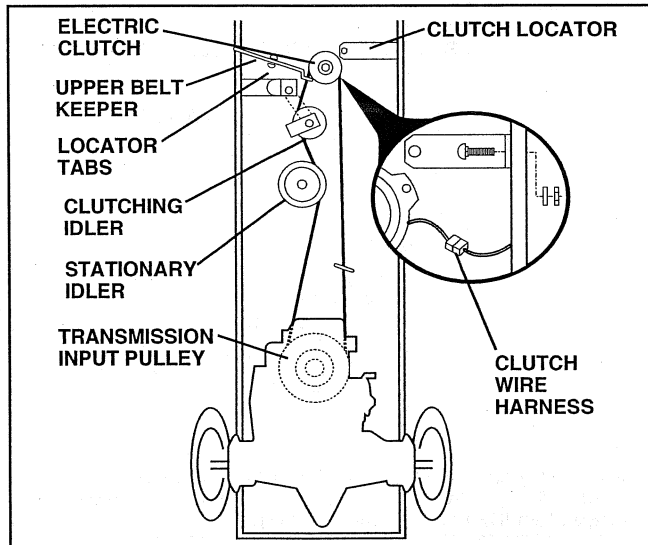

FIG. 29

- Disconnect clutch wire harness.
- Remove clutch locator.
- Remove upper belt keeper.
- Remove belt from stationary idler and clutching idler.
- Pull belt slack toward rear of tractor. Carefully remove belt upwards from transmission input pulley and over cooling fan blades.
- Pull belt toward front of tractor and remove downwards from around electric clutch.
- Install new belt by reversing above procedure.

**IMPORTANT:** MAKE SURE UPPER BELT KEEPER IS POSITIONED PROPERLY BETWEEN LOCATOR TABS AND ELECTRIC CLUTCH WIRE CONNECTION IS SECURE.

## TO ADJUST MOTION CONTROL LEVER (See Fig. 29)

The motion control lever has been preset at the factory and adjustment should not be necessary.

If for any reason the motion control lever will not hold its position while at a selected speed, it may be adjusted at the friction pack located on the right side of transmission.

- Park tractor on level surface. Stop tractor by turning ignition key to "OFF" position, and engage parking brake.
- Adjust motion control lever by tightening adjustment locknut one half (1/2) turn.

**NOTE:** If for any reason the effort to move the motion control lever becomes too excessive, reverse the above adjustment procedure by loosening locknut 1/4 to 1/2 turn.

Road test tractor after adjustment and repeat procedure if necessary.

## TRANSMISSION REMOVAL/REPLACEMENT

Should your transmission require removal for service or replacement, it should be purged after reinstallation and before operating the tractor. See "PURGE TRANSMISSION" in the Operation section of this manual.

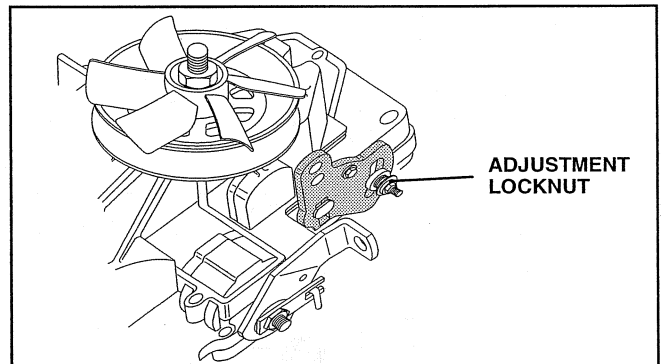

FIG. 29

## TO ADJUST STEERING WHEEL ALIGNMENT

If steering wheel crossbars are not horizontal (left to right) when wheels are positioned straight forward, remove steering wheel and reassemble per instructions in the Assembly section of this manual.

## FRONT WHEEL TOE-IN/CAMBER

The front wheel toe-in and camber are not adjustable on your tractor. If damage has occurred to affect the front wheel toe-in or camber, contact your nearest authorized service center/department.

# SERVICE AND ADJUSTMENTS

## TO REMOVE WHEEL FOR REPAIRS (See Fig. 30)

- Block up axle securely.
- Remove axle cover, retaining ring and washers to allow wheel removal (rear wheel contains a square key - Do not lose).
- Repair tire and reassemble.
- On rear wheels only: align grooves in rear wheel hub and axle. Insert square key.
- Replace washers and snap retaining ring securely in axle groove.
- Replace axle cover.

**NOTE:** To seal tire punctures and prevent flat tires due to slow leaks, tire sealant may be purchased from your local parts dealer. Tire sealant also prevents tire dry rot and corrosion.

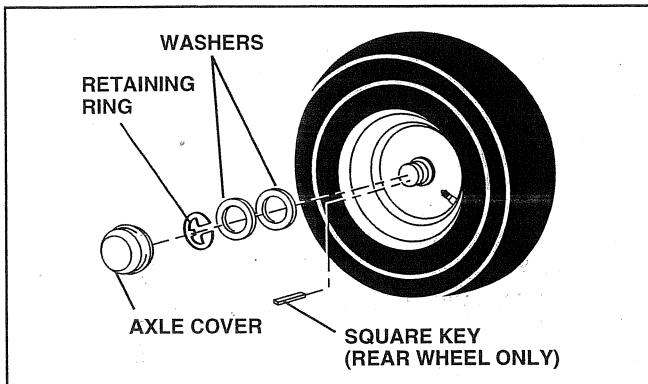

FIG. 30

## TO START ENGINE WITH A WEAK BATTERY (See Fig. 31)



**CAUTION:** Lead-acid batteries generate explosive gases. Keep sparks, flame and smoking materials away from batteries. Always wear eye protection when around batteries.

If your battery is too weak to start the engine, it should be recharged. If "jumper cables" are used for emergency starting, follow this procedure:

**IMPORTANT:** YOUR TRACTOR IS EQUIPPED WITH A 12 VOLT NEGATIVE GROUND SYSTEM. THE OTHER VEHICLE MUST ALSO BE A 12 VOLT NEGATIVE GROUND SYSTEM. DO NOT USE YOUR TRACTOR BATTERY TO START OTHER VEHICLES.

### TO ATTACH JUMPER CABLES -

- Connect each end of the RED cable to the POSITIVE (+) terminal of each battery, taking care not to short against chassis.
- Connect one end of the BLACK cable to the NEGATIVE (-) terminal of fully charged battery.
- Connect the other end of the BLACK cable to good CHASSIS GROUND, away from fuel tank and battery.

### TO REMOVE CABLES, REVERSE ORDER -

- BLACK cable first from chassis and then from the fully charged battery.
- RED cable last from both batteries.

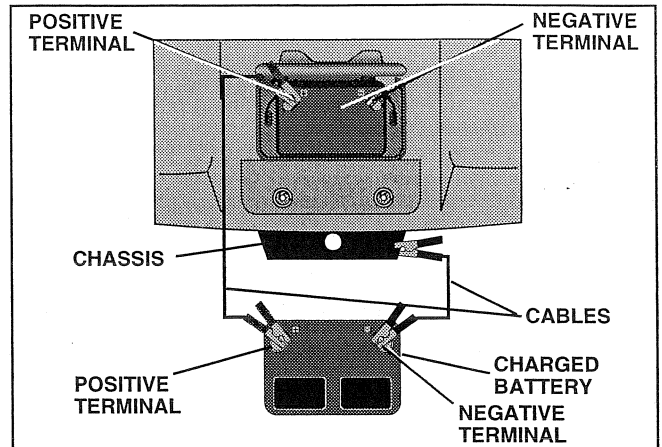

FIG. 31

## TO REPLACE HEADLIGHT BULB

- Raise hood.
- Pull bulb holder out of the hole in the backside of the grill.
- Replace bulb in holder and push bulb holder securely back into the hole in the backside of the grill.
- Close hood.

## INTERLOCKS AND RELAYS

Loose or damaged wiring may cause your tractor to run poorly, stop running, or prevent it from starting.

- Check wiring. See electrical wiring diagram in the Repair Parts section of this manual.

## TO REPLACE FUSE

Replace with 30 amp automotive-type plug-in fuse. The fuse holder is located behind the dash.

## TO REMOVE HOOD AND GRILL ASSEMBLY (See Fig. 32)

- Raise hood.
- Unsnap headlight wire connector.
- Stand in front of tractor. Grasp hood at sides, tilt toward engine and lift off of tractor.
- To replace, reverse above procedures.

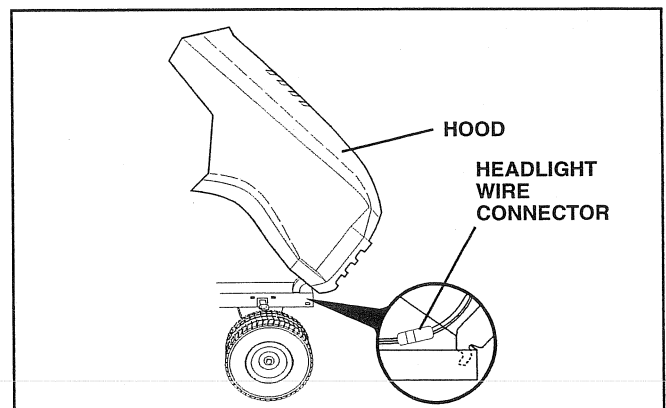

FIG. 32

# SERVICE AND ADJUSTMENTS

## ENGINE

### TO ADJUST THROTTLE CONTROL CABLE (See Fig. 33)

The throttle control has been preset at the factory and adjustment should not be necessary. Check adjustment as described below before loosening cable. If adjustment is necessary, proceed as follows:

- With engine not running, move throttle control lever from slow to choke position. Slowly move lever from choke to fast position.
- Check to see if hole in throttle lever and hole in speed control bracket are aligned.
- If holes are not aligned, loosen cable clamp screw and align the holes by inserting a pencil or a 1/4" drill bit through both holes.
- Pull throttle cable up to remove slack and tighten cable clamp screw. Remove alignment pencil or drill bit.

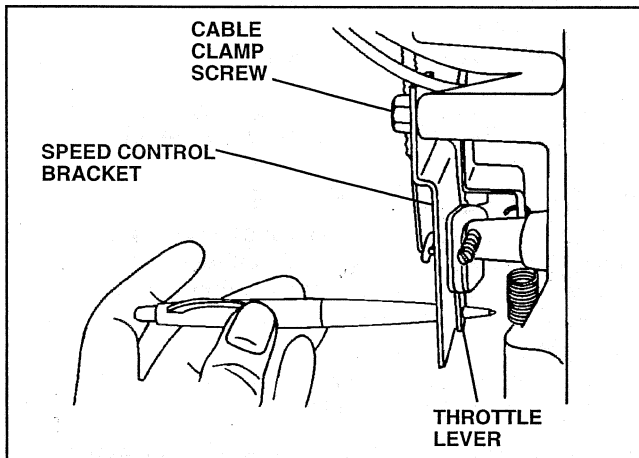

FIG. 33

### TO ADJUST CARBURETOR (See Fig. 34)

The carburetor has been preset at the factory and adjustment should not be necessary. However, minor adjustment may be required to compensate for differences in fuel, temperature, altitude or load. If the carburetor does need adjustment, proceed as follows:

In general, turning the adjusting needles **in** (clockwise) decreases the supply of fuel to the engine giving a leaner fuel/air mixture. Turning the adjusting needles **out** (counterclockwise) increases the supply of fuel to the engine giving a richer fuel/air mixture.

**IMPORTANT:** DAMAGE TO THE NEEDLES AND THE SEATS IN CARBURETOR MAY RESULT IF NEEDLE IS TURNED IN TOO TIGHT.

**NOTE:** The carburetor on this engine is low emission. It is equipped with an idle fuel adjusting needle with a limiter cap, which allows some adjustment within the limits allowed by the cap. Do not attempt to remove the limiter cap. The limiter cap cannot be removed without breaking the adjusting needle.

- Be sure you have a clean air filter and the throttle control cable is adjusted properly (see above).
- Start engine and allow to warm for five minutes. Make adjustments with engine running and shift/motion control lever in neutral (N) position.
- **Idle speed setting** - With throttle control lever in slow position, engine should idle at 1750 RPM. If engine idles too slow or fast, turn idle speed adjusting screw in or out until correct idle is attained.
- **Idle fuel needle setting** - With throttle control lever in slow position, turn idle fuel adjustment needle **in** (clockwise) until engine begins to die and then turn **out** (counterclockwise) until engine runs rough. Turn needle to a point midway between those two positions.
- Recheck idle speed. Readjust if necessary.

### ACCELERATION TEST -

- Move throttle control lever from slow to fast position. If engine hesitates or dies, turn idle fuel adjusting needle **out** (counterclockwise) 1/8 turn. Repeat test and continue to adjust, if necessary, until engine accelerates smoothly.

High speed stop is factory adjusted. Do not adjust - damage may result.

**IMPORTANT:** NEVER TAMPER WITH THE ENGINE GOVERNOR, WHICH IS FACTORY SET FOR PROPER ENGINE SPEED. OVERSPEEDING THE ENGINE ABOVE THE FACTORY HIGH SPEED SETTING CAN BE DANGEROUS. IF YOU THINK THE ENGINE-GOVERNED HIGH SPEED NEEDS ADJUSTING, CONTACT YOUR NEAREST AUTHORIZED SERVICE CENTER/DEPARTMENT, WHICH HAS PROPER EQUIPMENT AND EXPERIENCE TO MAKE ANY NECESSARY ADJUSTMENTS.

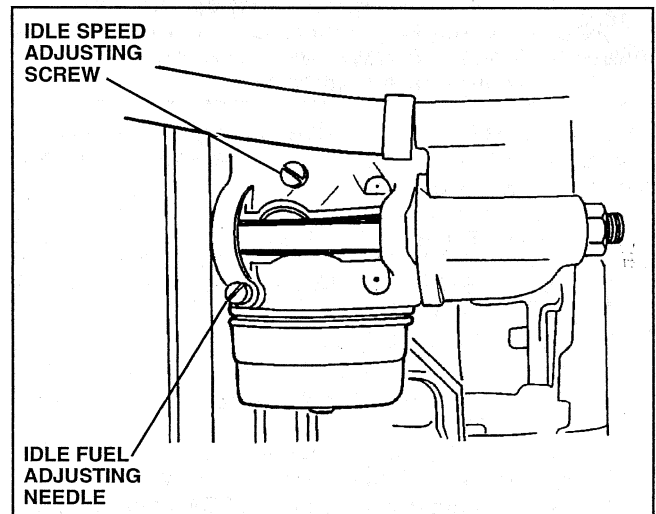

FIG. 34

# STORAGE

Immediately prepare your tractor for storage at the end of the season or if the tractor will not be used for 30 days or more.



**CAUTION:** Never store the tractor with gasoline in the tank inside a building where fumes may reach an open flame or spark. Allow the engine to cool before storing in any enclosure.

## TRACTOR

Remove mower from tractor for winter storage. When mower is to be stored for a period of time, clean it thoroughly, remove all dirt, grease, leaves, etc. Store in a clean, dry area.

- Clean entire tractor (See "CLEANING" in the Customer Responsibilities section of this manual).
- Inspect and replace belts, if necessary (See belt replacement instructions in the Service and Adjustments section of this manual).
- Lubricate as shown in the Customer Responsibilities section of this manual.
- Be sure that all nuts, bolts and screws are securely fastened. Inspect moving parts for damage, breakage and wear. Replace if necessary.
- Touch up all rusted or chipped paint surfaces; sand lightly before painting.

## BATTERY

- Fully charge the battery for storage.
- After a period of time in storage, battery may require recharging.
- To help prevent corrosion and power leakage during long periods of storage, battery cables should be disconnected and battery cleaned thoroughly (see "TO CLEAN BATTERY AND TERMINALS" in the Customer Responsibilities section of this manual).
- After cleaning, leave cables disconnected and place cables where they cannot come in contact with battery terminals.
- Be sure battery drain tube is securely attached.
- If battery is removed from tractor for storage, do not store battery directly on concrete or damp surfaces.

## ENGINE

### FUEL SYSTEM

**IMPORTANT:** IT IS IMPORTANT TO PREVENT GUM DEPOSITS FROM FORMING IN ESSENTIAL FUEL SYSTEM PARTS SUCH AS CARBURETOR, FUEL FILTER, FUEL HOSE, OR TANK DURING STORAGE. ALSO, EXPERIENCE INDICATES THAT ALCOHOL BLENDED FUELS (CALLED GASOHOL OR USING ETHANOL OR METHANOL) CAN ATTRACT MOISTURE WHICH LEADS TO SEPARATION AND FORMATION OF ACIDS DURING STORAGE. ACIDIC GAS CAN DAMAGE THE FUEL SYSTEM OF AN ENGINE WHILE IN STORAGE.

- Drain the fuel tank.
- Start the engine and let it run until the fuel lines and carburetor are empty.
- Never use engine or carburetor cleaner products in the fuel tank or permanent damage may occur.
- Use fresh fuel next season.

**NOTE:** Fuel stabilizer is an acceptable alternative in minimizing the formation of fuel gum deposits during storage. Add stabilizer to gasoline in fuel tank or storage container. Always follow the mix ratio found on stabilizer container. Run engine at least 10 minutes after adding stabilizer to allow the stabilizer to reach the carburetor. Do not drain the gas tank and carburetor if using fuel stabilizer.

### ENGINE OIL

Drain oil (with engine warm) and replace with clean engine oil. (See "ENGINE" in the Customer Responsibilities section of this manual).

### CYLINDERS

- Remove spark plug(s).
- Pour one ounce of oil through spark plug hole(s) into cylinder(s).
- Turn ignition key to "START" position for a few seconds to distribute oil.
- Replace with new spark plug(s).

## OTHER

- Do not store gasoline from one season to another.
- Replace your gasoline can if your can starts to rust. Rust and/or dirt in your gasoline will cause problems.
- If possible, store your tractor indoors and cover it to give protection from dust and dirt.
- Cover your tractor with a suitable protective cover that does not retain moisture. Do not use plastic. Plastic cannot breathe which allows condensation to form and will cause your tractor to rust.

**IMPORTANT:** NEVER COVER TRACTOR WHILE ENGINE AND EXHAUST AREAS ARE STILL WARM.

# TROUBLESHOOTING POINTS

PROBLEM	CAUSE	CORRECTION
<b>Will not start</b>	<ol style="list-style-type: none"> <li>1. Out of fuel.</li> <li>2. Engine not "CHOKED" properly.</li> <li>3. Engine flooded.</li> <li>4. Bad spark plug.</li> <li>5. Dirty air filter.</li> <li>6. Dirty fuel filter.</li> <li>7. Water in fuel.</li>   <li>8. Loose or damaged wiring.</li> <li>9. Carburetor out of adjustment.</li>   <li>10. Engine valves out of adjustment.</li> </ol>	<ol style="list-style-type: none"> <li>1. Fill fuel tank.</li> <li>2. See "TO START ENGINE" in Operation section.</li> <li>3. Wait several minutes before attempting to start.</li> <li>4. Replace spark plug.</li> <li>5. Clean/replace air filter.</li> <li>6. Replace fuel filter.</li> <li>7. Drain fuel tank and carburetor, refill tank with fresh gasoline and replace fuel filter.</li> <li>8. Check all wiring.</li> <li>9. See "To Adjust Carburetor" in Service Adjustments section.</li> <li>10. Contact an authorized service center/department.</li> </ol>
<b>Hard to start</b>	<ol style="list-style-type: none"> <li>1. Dirty air filter.</li> <li>2. Bad spark plug.</li> <li>3. Weak or dead battery.</li> <li>4. Dirty fuel filter.</li> <li>5. Stale or dirty fuel.</li> <li>6. Loose or damaged wiring.</li> <li>7. Carburetor out of adjustment.</li>   <li>8. Engine valves out of adjustment.</li> </ol>	<ol style="list-style-type: none"> <li>1. Clean/replace air filter.</li> <li>2. Replace spark plug.</li> <li>3. Recharge or replace battery.</li> <li>4. Replace fuel filter.</li> <li>5. Drain fuel tank and refill with fresh gasoline.</li> <li>6. Check all wiring.</li> <li>7. See "To Adjust Carburetor" in Service Adjustments section.</li> <li>8. Contact an authorized service center/department.</li> </ol>
<b>Engine will not turn over</b>	<ol style="list-style-type: none"> <li>1. Clutch/brake pedal not depressed.</li> <li>2. Attachment clutch is engaged.</li> <li>3. Weak or dead battery.</li> <li>4. Blown fuse.</li> <li>5. Corroded battery terminals.</li> <li>6. Loose or damaged wiring.</li> <li>7. Faulty ignition switch.</li> <li>8. Faulty solenoid or starter.</li> <li>9. Faulty operator presence switch(es).</li> </ol>	<ol style="list-style-type: none"> <li>1. Depress clutch/brake pedal.</li> <li>2. Disengage attachment clutch.</li> <li>3. Recharge or replace battery.</li> <li>4. Replace fuse.</li> <li>5. Clean battery terminals.</li> <li>6. Check all wiring.</li> <li>7. Check/replace ignition switch.</li> <li>8. Check/replace solenoid or starter.</li> <li>9. Contact an authorized service center/department.</li> </ol>
<b>Engine clicks but will not start</b>	<ol style="list-style-type: none"> <li>1. Weak or dead battery.</li> <li>2. Corroded battery terminals.</li> <li>3. Loose or damaged wiring.</li> <li>4. Faulty solenoid or starter.</li> </ol>	<ol style="list-style-type: none"> <li>1. Recharge or replace battery.</li> <li>2. Clean battery terminals.</li> <li>3. Check all wiring.</li> <li>4. Check/replace solenoid or starter.</li> </ol>
<b>Loss of power</b>	<ol style="list-style-type: none"> <li>1. Cutting too much grass/too fast.</li> <li>2. Throttle in "CHOKE" position.</li> <li>3. Build-up of grass, leaves and trash under mower.</li> <li>4. Dirty air filter.</li> <li>5. Low oil level/dirty oil.</li> <li>6. Faulty spark plug.</li> <li>7. Dirty fuel filter.</li> <li>8. Stale or dirty fuel.</li> <li>9. Water in fuel.</li>   <li>10. Spark plug wire loose.</li> <li>11. Dirty engine air screen/fins.</li> <li>12. Dirty/clogged muffler.</li> <li>13. Loose or damaged wiring.</li> <li>14. Carburetor out of adjustment.</li>   <li>15. Engine valves out of adjustment.</li> </ol>	<ol style="list-style-type: none"> <li>1. Set in "Higher Cut" position/reduce speed.</li> <li>2. Adjust throttle control.</li> <li>3. Clean underside of mower housing.</li> <li>4. Clean/replace air filter.</li> <li>5. Check oil level/change oil.</li> <li>6. Clean and regap or change spark plug.</li> <li>7. Replace fuel filter.</li> <li>8. Drain fuel tank and refill with fresh gasoline.</li> <li>9. Drain fuel tank and carburetor, refill tank with fresh gasoline and replace fuel filter.</li> <li>10. Connect and tighten spark plug wire.</li> <li>11. Clean engine air screen/fins.</li> <li>12. Clean/replace muffler.</li> <li>13. Check all wiring.</li> <li>14. See "To Adjust Carburetor" in Service Adjustments section.</li> <li>15. Contact an authorized service center/department.</li> </ol>
<b>Excessive vibration</b>	<ol style="list-style-type: none"> <li>1. Worn, bent or loose blade.</li> <li>2. Bent blade mandrel.</li> <li>3. Loose/damaged part(s).</li> </ol>	<ol style="list-style-type: none"> <li>1. Replace blade. Tighten blade bolt.</li> <li>2. Replace blade mandrel.</li> <li>3. Tighten loose part(s). Replace damaged parts.</li> </ol>

# TROUBLESHOOTING POINTS

PROBLEM	CAUSE	CORRECTION
Engine continues to run when operator leaves seat with attachment clutch engaged	<ol style="list-style-type: none"> <li>1. Faulty operator-safety presence control system.</li> </ol>	<ol style="list-style-type: none"> <li>1. Check wiring, switches and connections. If not corrected, contact an authorized service center/ department.</li> </ol>
Poor cut - uneven	<ol style="list-style-type: none"> <li>1. Worn, bent or loose blade.</li> <li>2. Mower deck not level.</li> <li>3. Buildup of grass, leaves, and trash under mower.</li> <li>4. Bent blade mandrel.</li> <li>5. Clogged mower deck vent holes from buildup of grass, leaves, and trash around mandrels.</li> </ol>	<ol style="list-style-type: none"> <li>1. Replace blade. Tighten blade bolt.</li> <li>2. Level mower deck.</li> <li>3. Clean underside of mower housing.</li> <li>4. Replace blade mandrel.</li> <li>5. Clean around mandrels to open vent holes.</li> </ol>
Mower blades will not rotate	<ol style="list-style-type: none"> <li>1. Obstruction in clutch mechanism.</li> <li>2. Worn/damaged mower drive belt.</li> <li>3. Frozen idler pulley.</li> <li>4. Frozen blade mandrel.</li> </ol>	<ol style="list-style-type: none"> <li>1. Remove obstruction.</li> <li>2. Replace mower drive belt.</li> <li>3. Replace idler pulley.</li> <li>4. Replace blade mandrel.</li> </ol>
Poor grass discharge	<ol style="list-style-type: none"> <li>1. Engine speed too slow.</li> <li>2. Travel speed too fast.</li> <li>3. Wet grass.</li> <li>4. Mower deck not level.</li> <li>5. Low/uneven tire air pressure.</li> <li>6. Worn, bent or loose blade.</li> <li>7. Buildup of grass, leaves and trash under mower.</li> <li>8. Mower drive belt worn.</li> <li>9. Blades improperly installed.</li> <li>10. Improper blades used.</li> <li>11. Clogged mower deck vent holes from buildup of grass, leaves, and trash around mandrels.</li> </ol>	<ol style="list-style-type: none"> <li>1. Place throttle control in "FAST" position.</li> <li>2. Shift to slower speed.</li> <li>3. Allow grass to dry before mowing.</li> <li>4. Level mower deck.</li> <li>5. Check tires for proper air pressure.</li> <li>6. Replace/sharpen blade. Tighten blade bolt.</li> <li>7. Clean underside of mower housing.</li> <li>8. Replace mower drive belt.</li> <li>9. Reinstall blades sharp edge down.</li> <li>10. Replace with blades listed in this manual.</li> <li>11. Clean around mandrels to open vent holes.</li> </ol>
Headlight(s) not working (if so equipped)	<ol style="list-style-type: none"> <li>1. Switch is "OFF".</li> <li>2. Bulb(s) burned out.</li> <li>3. Faulty light switch.</li> <li>4. Loose or damaged wiring.</li> <li>5. Blown fuse.</li> </ol>	<ol style="list-style-type: none"> <li>1. Turn switch "ON".</li> <li>2. Replace bulb(s).</li> <li>3. Check/replace light switch.</li> <li>4. Check wiring and connections.</li> <li>5. Replace fuse.</li> </ol>
Battery will not charge	<ol style="list-style-type: none"> <li>1. Bad battery cell(s).</li> <li>2. Poor cable connections.</li> <li>3. Faulty regulator (if so equipped).</li> <li>4. Faulty alternator.</li> </ol>	<ol style="list-style-type: none"> <li>1. Replace battery.</li> <li>2. Check/clean all connections.</li> <li>3. Replace regulator.</li> <li>4. Replace alternator.</li> </ol>
Loss of drive	<ol style="list-style-type: none"> <li>1. Freewheel control in "disengaged" position.</li> <li>2. Motion drive belt worn, damaged, or broken.</li> <li>3. Air trapped in transmission during shipment or servicing.</li> </ol>	<ol style="list-style-type: none"> <li>1. Place freewheel control in "engaged" position.</li> <li>2. Replace motion drive belt.</li> <li>3. Purge transmission.</li> </ol>
Engine "backfires" when turning engine "OFF"	<ol style="list-style-type: none"> <li>1. Engine throttle control not set at "SLOW" position for 30 seconds before stopping engine.</li> </ol>	<ol style="list-style-type: none"> <li>1. Move throttle control to "SLOW" position and allow to idle for 30 seconds before stopping engine.</li> </ol>

---

# SERVICE NOTES

---



# REPAIR PARTS

TRACTOR - MODEL NO. LTH130 (954140005 ), PRODUCT NO. 954 14 00-05

## SCHEMATIC

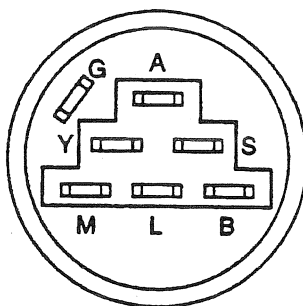
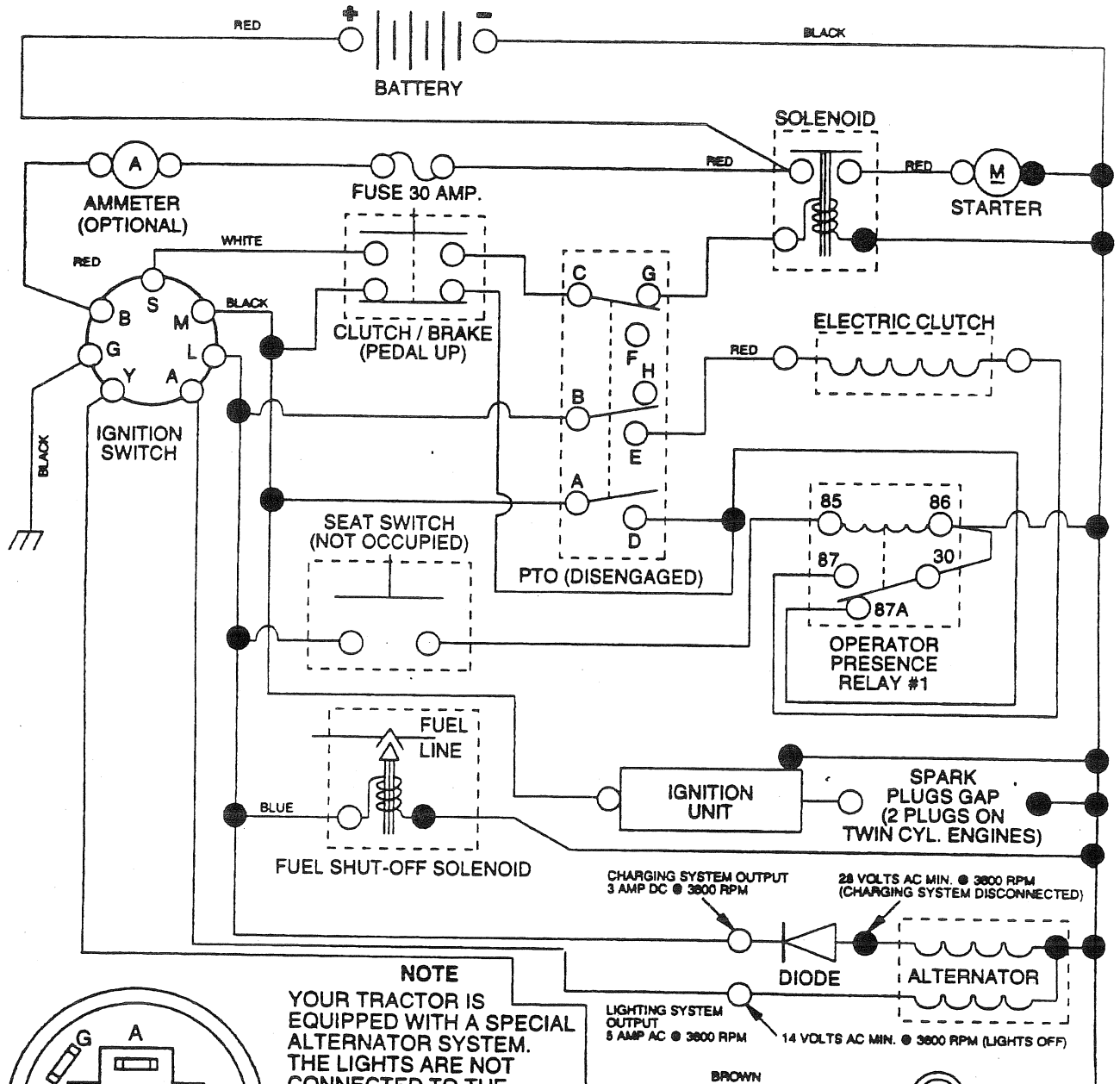

**NOTE**  
 YOUR TRACTOR IS EQUIPPED WITH A SPECIAL ALTERNATOR SYSTEM. THE LIGHTS ARE NOT CONNECTED TO THE BATTERY, BUT HAVE THEIR OWN ELECTRICAL SOURCE. BECAUSE OF THIS, THE BRIGHTNESS OF THE LIGHTS WILL CHANGE WITH ENGINE SPEED. AT IDLE THE LIGHTS WILL DIM. AS THE ENGINE IS SPEEDED UP, THE LIGHTS WILL BECOME THEIR BRIGHTEST.

**IGNITION SWITCH**

POSITION	CIRCUIT	"MAKE"
OFF	G + M + L	NONE
RUN/LIGHT	B + L	A + Y
RUN	B + L	NONE
START	B + L + S	NONE

**WIRING INSULATED CLIPS**  
 NOTE: IF WIRING INSULATED CLIPS WERE REMOVED FOR SERVICING OF UNIT, THEY SHOULD BE REPLACED TO PROPERLY SECURE YOUR WIRING.

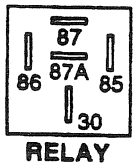

**PTO SWITCH**

POSITION	CIRCUIT
OFF	C + G, B + H
ON	C + F, B + E, A + D

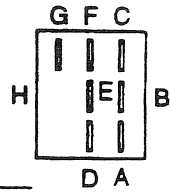

NON-REMOVABLE CONNECTIONS      REMOVABLE CONNECTIONS



# REPAIR PARTS

TRACTOR - MODEL NO. LTH130 (954140005F), PRODUCT NO. 954 14 00-05

## ELECTRICAL

KEY NO.	PART NO.	DESCRIPTION
1	532144925	Battery 12 Volt 25 AMP
2	874760412	Bolt Hex Hd 1/4-20unc X 3/4
3	819091016	Washer 9/32 X 5/8 X 16 Ga.
4	810040400	Washer Lock Hvy Helical 1/4
6	873220400	Nut Fin Hex 1/4-20 Unc
8	532156417	Case Battery Mech Hinge
16	532153664	Switch Interlock Push-In
19	810090400	Washer Lock 1/4
20	873350400	Nut Jam Hex 1/4-20 Unc
21	532136850	Harness Asm Light W/4152j
22	532004152	Bulb Light #1156
24	532124780	Cable Battery 6 Ga 11" red
25	532146147	Cable Battery 6 Ga 44" red w/16 wire
26	532108824	Fuse 30 AMP Auto Green
28	532124773	Cable Ground 6 Ga 12" black
29	532160784	Switch Plunger Normal OP Olive
30	532140301	Switch Ign 4 pos w/lights
31	532124211	Nut Ignition
32	532141226	Cover Sw Ignition
33	532122147	Key Ign Modelled Generic
40	532160720	Harness Ign.
41	871110408	Bolt Blk Fin Hex 1/4 - 20 x 1/2
42	532131563	Cover Terminal Red
43	532145673	Solenoid
44	873640400	Nut Keps Hex 1/4-20 Unc
48	532140844	Adapter Ammeter Rectangular
50	532154959	Switch PTO 3PDT Black Delta 96
51	532140405	Ring Retainer PTO
52	532141940	Protection Wire Loop
70	532140426	Harness, Eng. kohl Cmd-L Dual
80	532146685	Harness Clutch EVX
81	532109748	Relay Asm
88	532161366	Harness Eng Koh Cv15 Stator

**NOTE:** All component dimensions given in U.S. inches.  
1 inch = 25.4 mm.

# REPAIR PARTS

TRACTOR - MODEL NO. LTH130 (954140005F), PRODUCT NO. 954 14 00-05

## CHASSIS AND ENCLOSURES

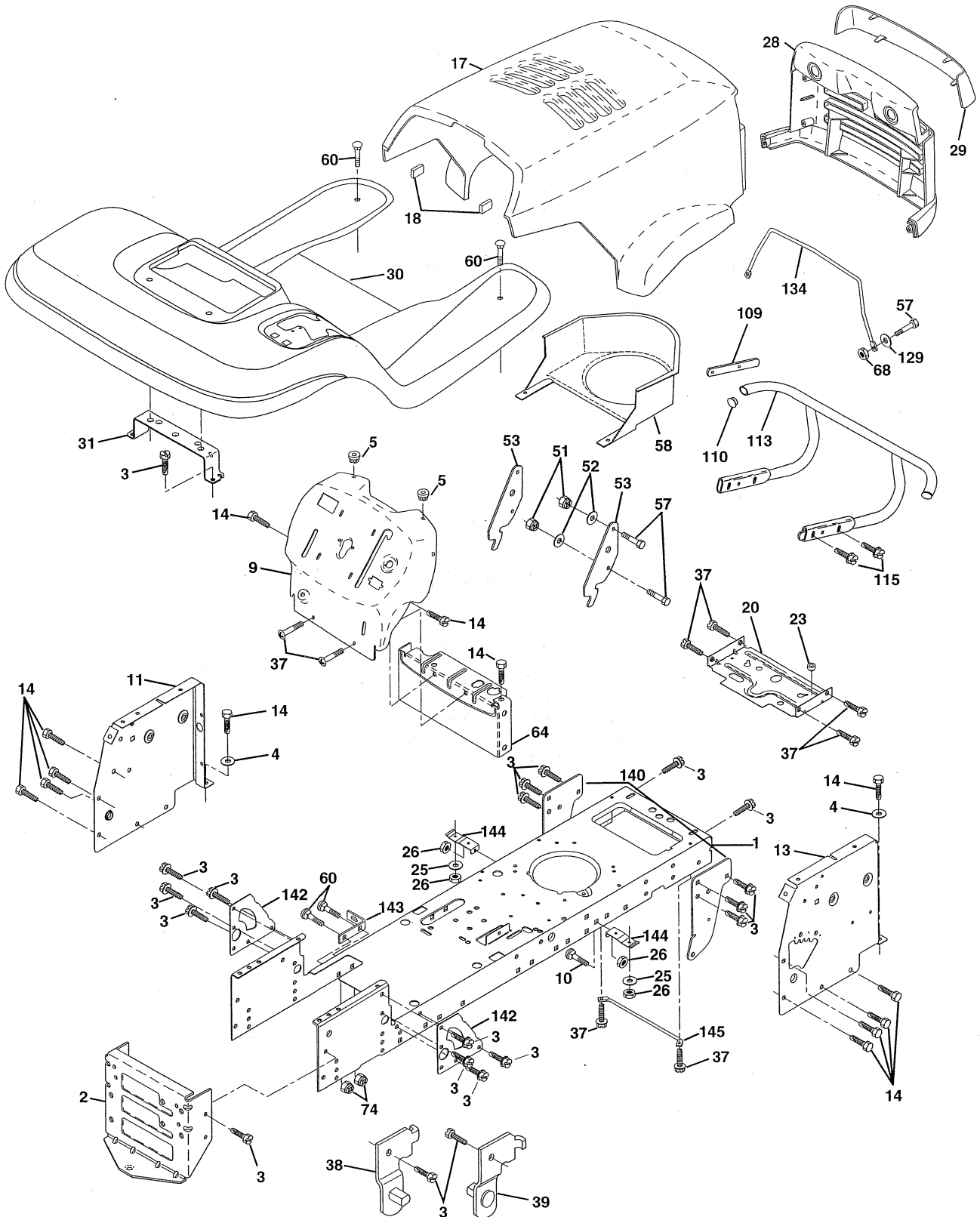

# REPAIR PARTS

TRACTOR - MODEL NO. LTH130 (954140005F), PRODUCT NO. 954 14 00-05

## CHASSIS AND ENCLOSURES

KEY NO.	PART NO.	DESCRIPTION
1	532160392	Chassis STL Stamping 98
2	532140356	Drawbar, Stretch
3	817490612	Screw Thdrol 3/8-16x3/4 Ty-tt
4	819131216	Washer 13/32 x 3/4 x 16 Ga.
5	532155272	Bumper Hood/Dash
9	532157409	Dash P/L M, N/AMM N/HM Grey
10	872140608	Bolt Carriage 3/8-16 x 1
11	532155927	Panel Dash Lh
13	532157262	Panel Dash Rh
14	817490608	Screw Thdrol 3/8-16x1/2 Ty-tt
17	532156051	Hood LT/PL Husqvarna
18	532126938	Bumper Hood
20	532156437	Plate Mtg Battery Fuel Tank Fr
23	532124028	Bushing
25	819131312	Washer 13/32 X 13/16 X 12 Ga
26	873800600	Nut Lock Hex W/Ins 3/8-16 Unc
28	532149776	Grille LT/PL Husqvarna
29	532149777	Lens LT/PL Husqvarna
30	532156489	Fender Footrest STLT Pnt
31	532139976	Bracket Support Fender
37	817490508	Screw Thdrol 6/16-18 x 1/2 TYT
38	532139886	Bracket, Asm. Pivot, L.H., Mower Rear
39	532139887	Bracket, Asm. Pivot, R.H., Mower Rear
51	873800400	Nut Lock Hex W/Ins 1/4-20
52	819091416	Washer 9/32 x 7/8 x 16 Ga.
53	532150067	Bracket Pnt. Pick off LT/PL Husqvarna
57	874780412	Bolt Hex 1/4-20 x 3/4
58	532150127	Air Duct Engine P/L
60	872140606	Bolt Rdhd Sqnk 3/8-16unc x 3/4
64	532154798	Dash Lower STLT
68	873510400	Nut Keps Hex 1/4-20 UNC
74	873680600	Nut Crownlock 3/8-16 UNC
109	532141461	Bracket Extension Bumper
110	532143679	Plug Plastic
113	532150300	Bumper Asm.
115	817490620	Screw Thdrol 3/8-16 x 1-1/4
129	819091016	Washer 9/32 x 5/8 x 16 Ga.
134	532160219	Rod Support Hood LT/PL Husq.
140	532158418	Bracket Suspension Front
142	532156095	Plate Reinforcement STLT
143	532154966	Bracket Swaybar Chassis
144	532154207	Bracket Pnt Footrest STLT
145	532156524	Rod Pivot Chassis/Hood
--	532005479	Plug Button

**NOTE:** All component dimensions given in U.S. inches  
1 inch = 25.4 mm

# REPAIR PARTS

TRACTOR - MODEL NO. LTH130 (954140005F), PRODUCT NO. 954 14 00-05

## DRIVE

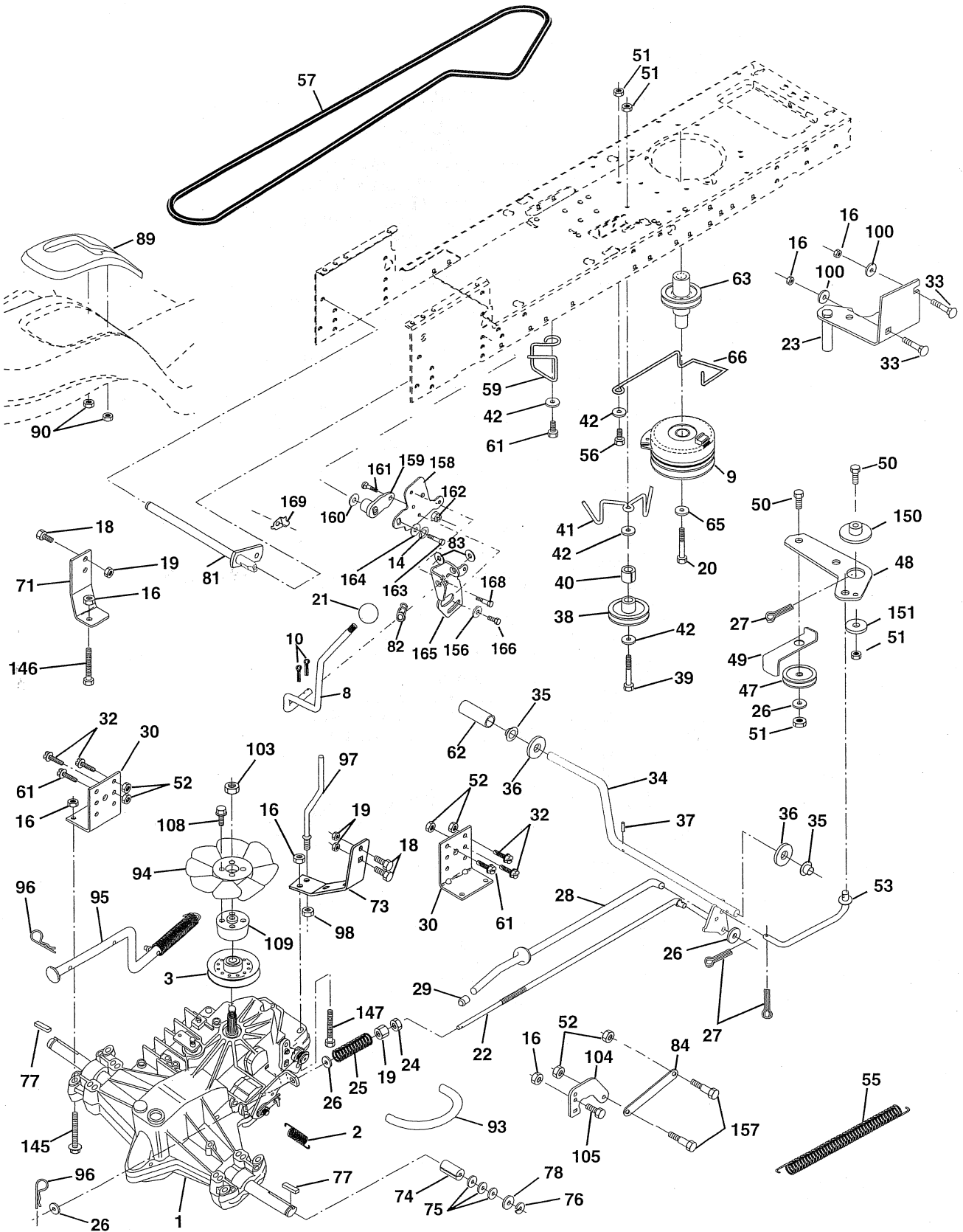

# REPAIR PARTS

TRACTOR - MODEL NO. LTH130 (954140005F), PRODUCT NO. 954 14 00-05

## DRIVE

KEY PART NO.	NO.	DESCRIPTION	KEY PART NO.	NO.	DESCRIPTION
1	-----	Transaxle (See Breakdown) Hydro Gear, Model No. 310-0500	61	817490612	Screw Thdrol. 3/8-16 x 3/4 Ty. TT
2	532142431	Spring, Return, Brake	62	532124872	Cover, Pedal
3	532144698	Pulley, Transaxle	63	532161408	Pulley, Clutch Electric EVX
8	532154792	Rod Shift Fender STLT	65	810040700	Washer
9	532145028	Clutch, Elect. EVX LT Mag 5217-2	66	532161488	Keeper Belt Engine Hydro
10	876020416	Pin Cotter 1/8 x 1 CAD	71	532141417	Strap Torque Lh Hydro
15	874490540	Bolt, Hex Flghd 5/16-18 Gr. 5	73	532141418	Strap Torque Rh Hydro
16	873800500	Nut Lock Hex W/Ins. 5/16-18 Unc P	74	532121199	Spacer, Split
18	874780616	Bolt Fin Hex 3/8-16 Unc x 1 Gr. 5	75	532121749	Washer 25/32 x 1-1/4 x 16 Gauge
19	873800600	Nut Lock Hex W/Wsh 3/8-16 Unc	76	812000001	E-Ring
20	532150280	Bolt Hex 7/16-20 x 4-1/4 Ga. 1.38	77	532123583	Key, Square
21	532121274	Knob, Duckhead 1/2-13	78	532121748	Washer 25/32 x 1-5/8 x 16 Gauge
22	532145627	Rod, Brake Hydro	81	532161081	Shaft Asm. Cross Hydro
23	532154978	Bracket, Asm Clutch Mtg EVX	82	532123782	Spring Torsion T/A
24	873350600	Nut	83	819171216	Washer 17/32 x 3/4 x 16 Ga.
25	532106888	Spring, Brake Rod	84	532141423	Rod, Tie Hydro
26	819131316	Washer	86	532157480	Bushing Rod Steering 629/632 ID
27	876020412	Pin Cotter 1/8 x 3/4 CAD.	87	819212016	Washer 21/32 x 1-1/4 x 16 Ga.
28	532145204	Rod, Parking Brake	88	812000008	Ring Klip #5304-62
29	532071673	Cap, Parking Brake	89	532158388	Console, Shift
30	532130807	Bracket, Transaxle	90	532124346	Nut, Self-Thd Wsh-hd 1/4 Zinc
32	874760512	Bolt Hex Hd 5/16-18 Unc x 3/4	93	532142564	Line Fuel Hydro 4"
33	872140506	Bolt Rdhd Sqnk 5/16-18 UNC x 3/4	94	532140462	Fan, Hydro 7"
34	532155071	Shaft, Foot Pedal	95	532144643	Control Asm Bypass Hydro
35	532120183	Bearing, Nylon	96	532124788	Retainer Spring 1" Zinc/Cad
36	819211616	Washer	97	532144201	Keeper Belt Rh Hydro
37	532124963	Pin, Roll	98	873510600	Nut Keps Hex 3/8-16 Unc
38	532123674	Pulley, Idler, Flat	100	819111216	Washer 11/32 x 3/4 x 16 Ga.
39	874760644	Bolt	103	873940800	Nut Nylon Insert 1/2-20 Unf.
40	532124965	Spacer, Split	104	532141421	Arm, Control Hydro
41	532154777	Keeper, Belt Idler	105	871070516	Screw Cap Hex 5/16 x 18 x 1
42	819131312	Washer 13/32 x 13/16 x 12 Gauge	106	874780520	Bolt Fin Hex 5/16-18 Unc x 1-1/4
47	532127783	Pulley, Idler, V-Groove	108	817541026	Screw Hex Wh Hd #10-24 x
49	532123205	Retainer, Belt	109	532145098	Adaptor Fan Hydro LT Hyd Alum
50	874760624	Bolt	146	874490536	Bolt Hex Flghd 5/16-18 x 2-1/4
51	873680600	Nut	147	874990524	Bolt Hex Flghd 5/16-18 x 1-1/2
52	873680500	Nut Crownlock 5/16-18	148	532159103	Spacer
53	532105710	Link, Clutch	149	532122052	Spacer Retainer PM Mower
55	532105709	Spring, Return, Clutch	150	532150935	Bushing Nylon Collered
56	874760620	Bolt Fin Hex 3/8-16 UNC x 1-1/4	151	819133210	Washer 13/32 x 2 x 10 Ga.
57	532161850	V-Belt, Ground Drive			
59	532140312	Keeper, Center Span			

**NOTE:** All component dimensions give in U.S. inches.  
1 inch = 25.4 mm.

# REPAIR PARTS

TRACTOR - MODEL NO. LTH130 (954140005F), PRODUCT NO. 954 14 00-05

## STEERING ASSEMBLY

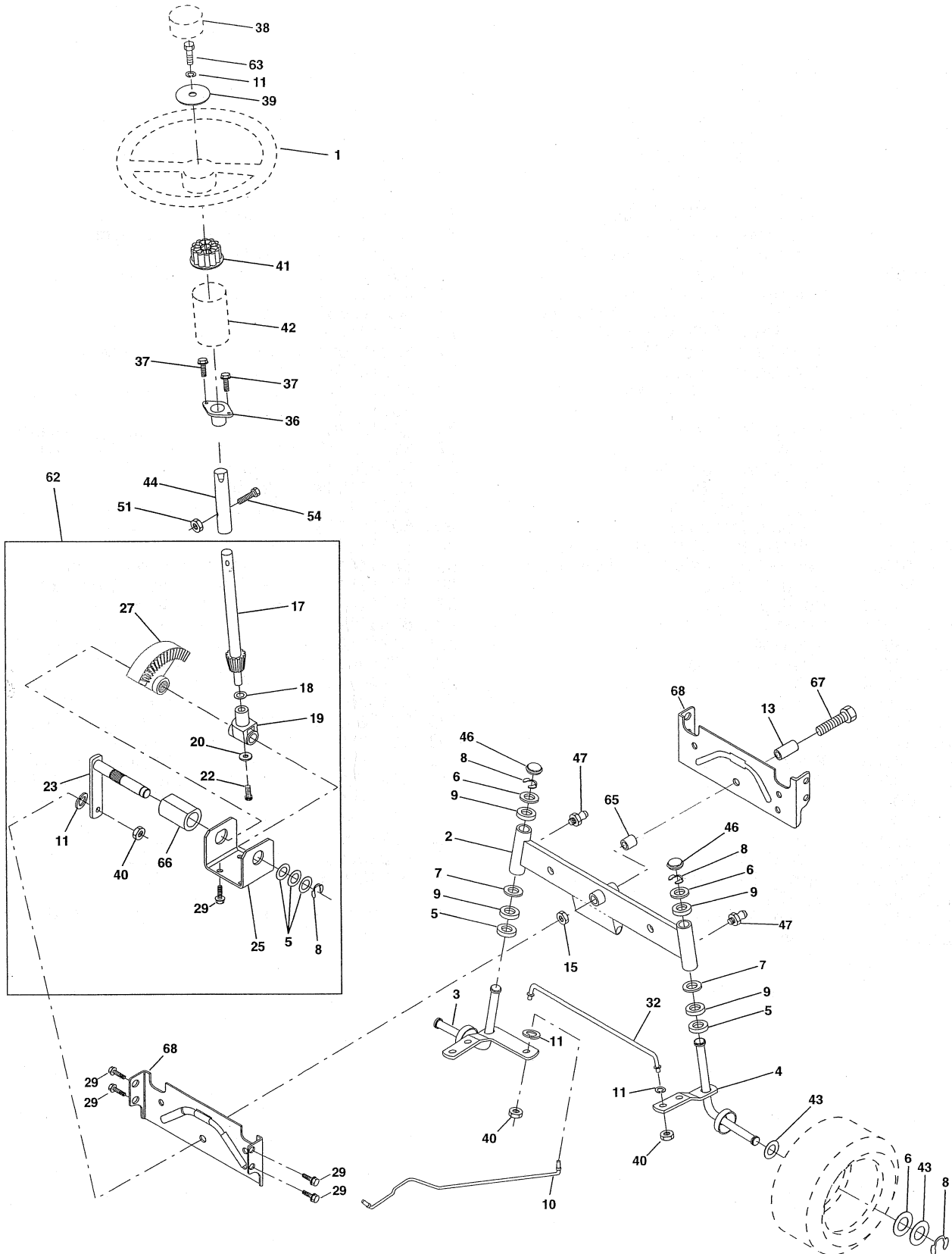



# REPAIR PARTS

TRACTOR - MODEL NO. LTH130 (954140005F), PRODUCT NO. 954 14 00-05

## STEERING ASSEMBLY

KEY NO.	PART NO.	DESCRIPTION
1	532124415	Wheel Steering
2	532137094	Axle Front Casting Machined
3	532157479	Spindle Asm LH Cast 15"
4	532157478	Spindle Asm RH Cast 15"
5	532124931	Bearing Race Thrust Harden
6	532121748	Washer 25/32 X 1-5/8 X 16 Ga
7	819272016	Washer 27/32 X 1-1/4 X 16 Ga
8	812000029	Ring Klip #t5304-75
9	532124937	Bearing Col Strg Blk
10	532154432	Link Drag Extended Cast
11	810040600	Washer Lock Hvy Hlcl Spr 3/8
13	532154779	Bearing Axle STLT/GT
15	873901000	Nut Lock Flange 5/8-11 Unc
17	532156546	Shaft Asm Strg
18	532057079	Washer Thrust 515x 750x 033
19	532124035	Support Shaft
20	532126684	Washer Shim 1/4 X 5/8 X 062
22	871200410	Screw Hex Socket 1/4-20 x 5/8
23	532127501	Shaft Asm Pittman
25	532154406	Bracket Steering
27	532136874	Gear Sector
29	817490612	Screw Thdrol 3/8-16x3/4 Ty-tt
32	532137347	Rod Asm Tie Ball J Adj VGT
36	532155099	Bushing Strg
37	532152927	Screw
38	532124416	Insert Cap Strg Wh Au
39	819133808	Washer 13/32 X 2-3/8 X 8 Ga
40	532124701	Lock nut
41	532100711	Adaptor Wheel Strg
42	532155092	Boot Steering Shaft
43	532121749	Washer 25/32 X 1 1/4 X 16 Ga
44	532153720	Extension Steering Shaft LR/LT
46	532121232	Cap Spindle Fr Top Blk
47	532124836	Fitting Grease
51	873800500	Nut Lock Hex w/Ins 5/16-18
54	874780520	Bolt Fin Hex 5/16-18 Unc x 1-1/4
62	532156594	Kit, Steering Assembly Svc
63	874780616	Bolt Fin Hex 3/8-16unc x 1 Gr. 5
65	532154780	Spacer Axle
66	532154404	Bearing Arm Pittman
67	874781044	Bolt, Fin Hex 5/8-11 UNC x 2-3/4
68	532154429	Axle, Brace

**NOTE:** All component dimensions given in U.S. inches.  
1 inch = 25.4 mm.

# REPAIR PARTS

TRACTOR - MODEL NO. LTH130 (954140005F), PRODUCT NO. 954 14 00-05

## SEAT ASSEMBLY

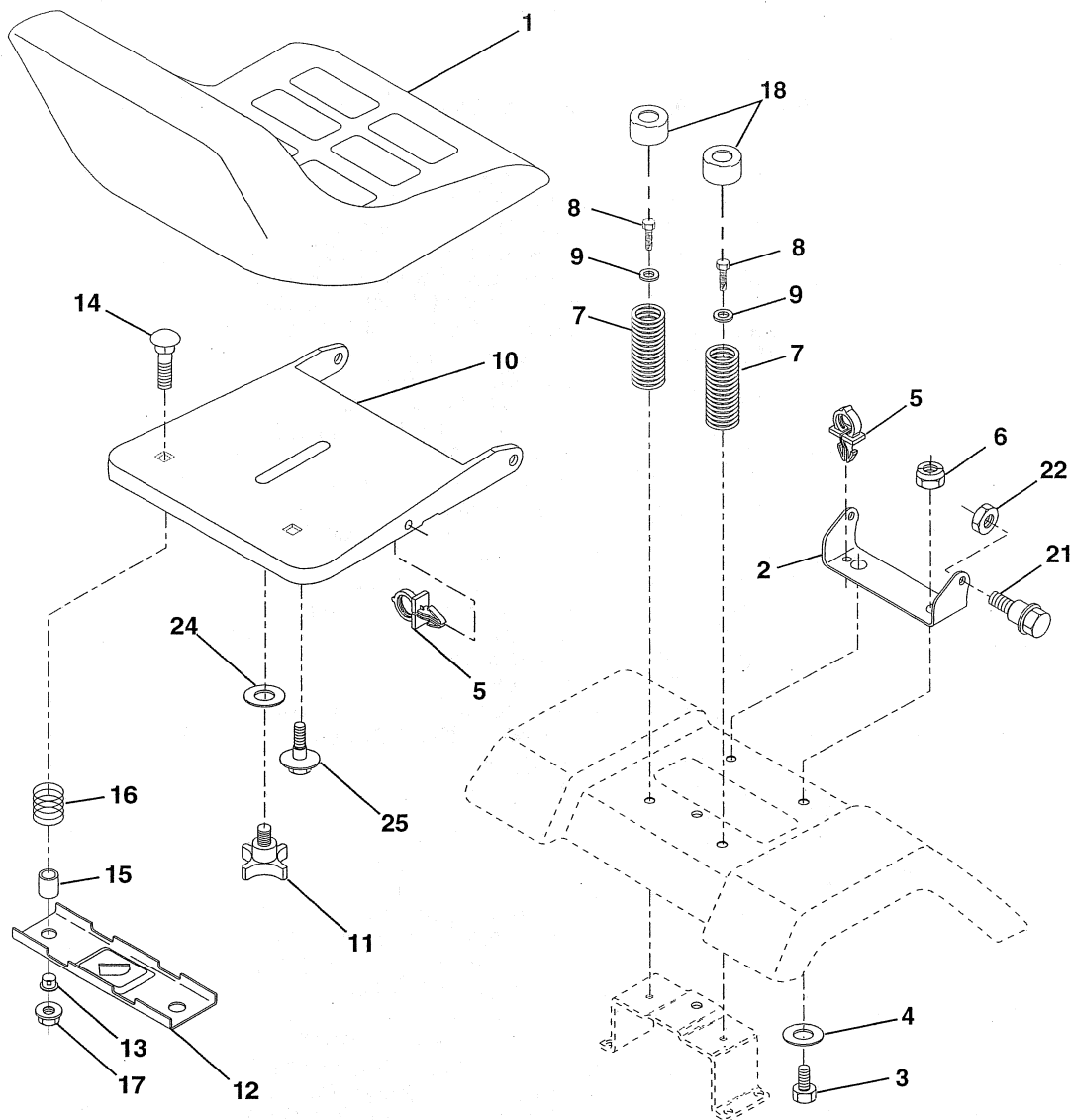

### KEY PART NO. NO.

### DESCRIPTION

1	532140838	Seat
2	532140551	Bracket Pivot Seat 8 720
3	874760616	Bolt Fin Hex 3/8-16unc X 1
4	819131610	Washer 13/32 X 1 X 10 Ga
5	532145006	Clip Push-In
6	873800600	Nut Hex w/Ins. 3/8-16 Unc
7	532124181	Spring Seat Cprsn 2 250 Blk Zi
8	817490616	Screw Thdrol 3/8-16 X 1 Ty-tt
9	819131614	Washer 13/32 X 1 X 14 Ga.
10	532155925	Pan Seat
11	532120068	Knob Seat 1/2-13 UNC Blk
12	532121246	Bracket Mounting Switch

### KEY PART NO. NO.

### DESCRIPTION

13	532121248	Bushing Snap Blk Nyl 50 Id
14	872050412	Bolt Rdhd Sqnk 1/4-20x1-1/2
15	532134300	Spacer Split 28x 96 Yel Zinc
16	532121250	Spring Cprsn 1 27 Blk Pnt
17	532123976	Nut Lock 1/4 Lge Flg Gr 5 Zinc
18	532124238	Cap Spring Seat
21	532153236	Bolt Shoulder 5/16-18 Unc
22	873800500	Nut Hex Lock W/Ins 5/16-18
24	819171912	Washer 17/32 X 1-3/16 X 12 Ga.
25	532127018	Bolt Shoulder 5/16-18 X 62

**NOTE:** All component dimensions given in U.S. inches.  
1 inch = 25.4 mm

# REPAIR PARTS

TRACTOR - MODEL NO. LTH130 (954140005F), PRODUCT NO. 954 14 00-05

## DECALS

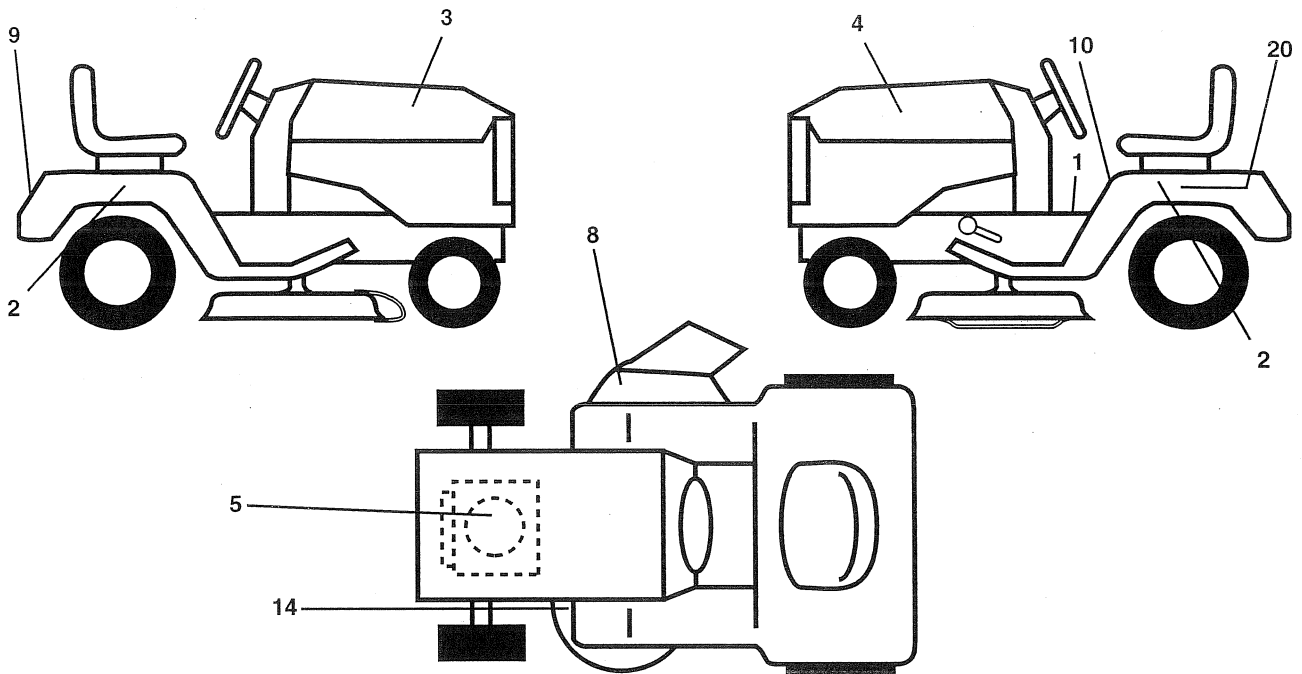

KEY NO.	PART NO.	DESCRIPTION	KEY NO.	PART NO.	DESCRIPTION
1	532157032	Decal Oper Step Thru Eng/Fr	--	532154516	Pad Footrest RH STLT
2	532157007	Decal Fender Ajuto Husq. Radius	--	532138311	Decal Handle Lft Height Adjust
3	532150725	Decal Hood RH	--	532142341	Decal Drawbar Cntrl Mvt Hyd LT
4	532150726	Decal Hood LH	--	532164804	Manual Owner's (English)
5	532151124	Decal HP Engine	--	532164805	Manual Owner's (French)
8	532137259	Decal Warning	Available accessories not included with tractor:		
9	532150617	Decal Fender Husq	--	LSB42	42" Snow Blower
10	532157140	Decal Fender Danger Eng/Fr	--	LC05	Wheel Wts (pair)
14	532160396	Decal V-Belt Schematic	--	CH12	Tire Chains 18 x 8.5 x 8
20	532145005	Decal Bat Dan/Psn	--	LBD48	48" Snow Blade
--	532154515	Pad Footrest LH STLT	--	MP42	Mulch Plate

## WHEELS & TIRES

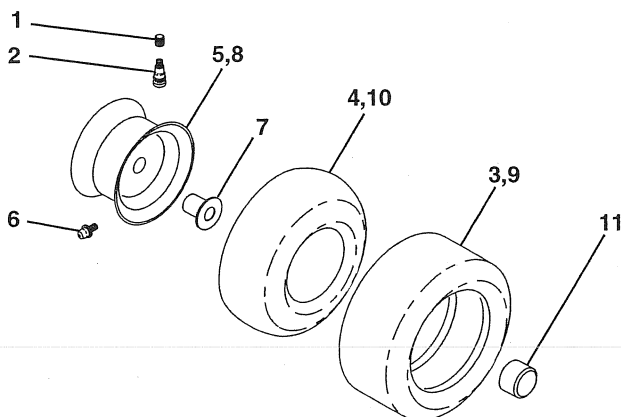

KEY NO.	PART NO.	DESCRIPTION
1	532059192	Cap Valve Tire
2	532065139	Stem Valve
3	532106222	Tire F Ts 15 X 6 0 - 6 Service
4	532059904	Tube Front (Service Item Only)
5	532138336	Rim Asm 6"front Silver Service
6	532124957	Fitting Grease (Front Wheel Only)
7	532124959	Bearing Flange (Front Wheel Only)
8	532138337	Rim Asm 8"rear Silver Service
9	532124635	Tire R Ts 18x8 5-8 C Service
10	532124926	Tube Rear (Service Item Only)
11	532104757	Cap Axle Blk 1 50 X 1 00
--	532144334	Sealant, Tire ( 10 oz. Tube)

**NOTE:** All component dimensions given in U.S. inches  
1 inch = 25.4 mm

# REPAIR PARTS

TRACTOR - MODEL NO. LTH130 (954140005F), PRODUCT NO. 954 14 00-05

## ENGINE

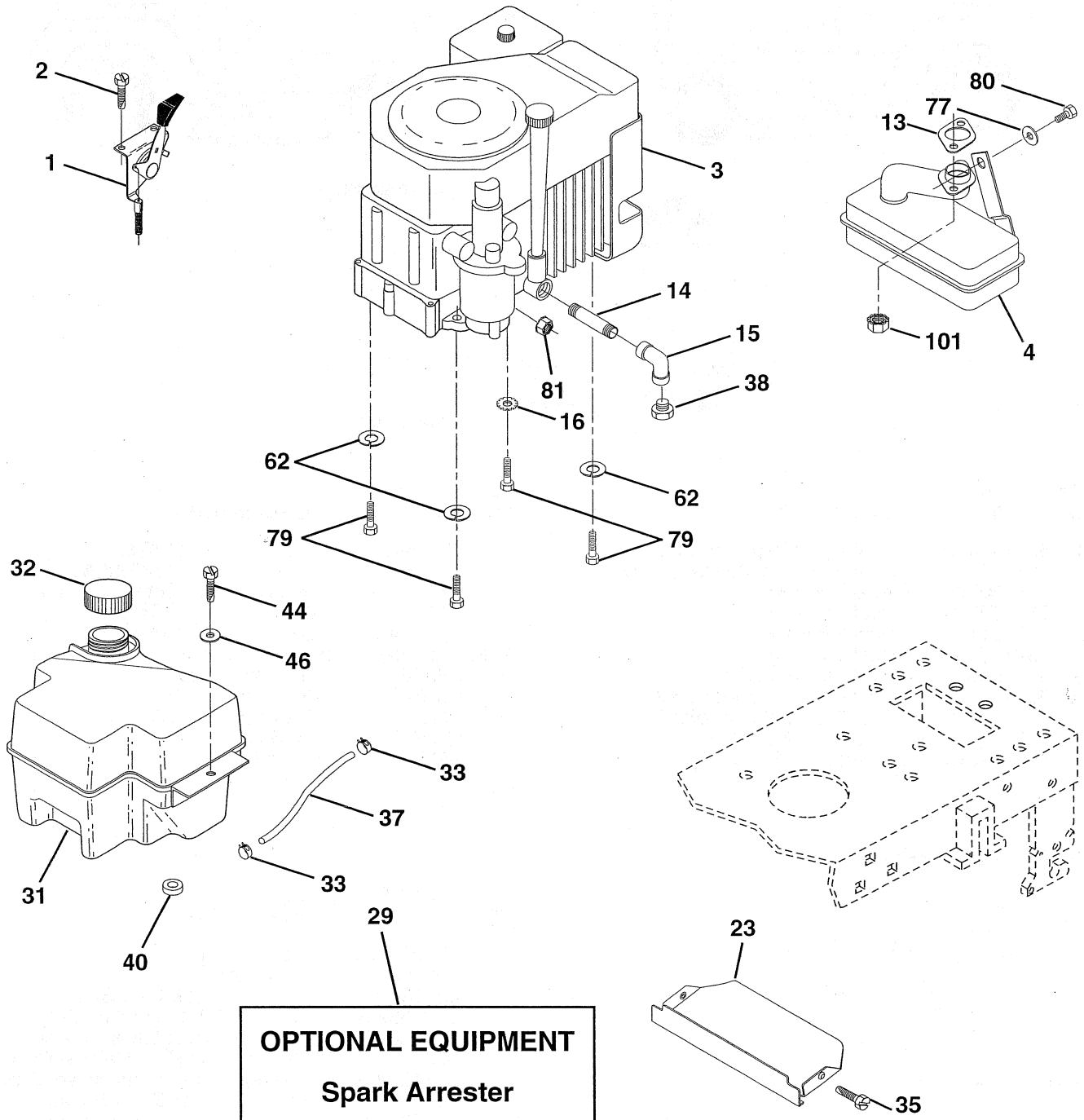

# REPAIR PARTS

TRACTOR - MODEL NO. LTH130 (954140005F), PRODUCT NO. 954 14 00-05

## ENGINE

KEY NO.	PART NO.	DESCRIPTION
1	532141296	Control THTICH 27 LH FLAG DOM
2	817720410	Screw Hex Thd Cut 1/4-20 x 5/8 T
3	-----	Engine Kohler
4	532159420	Muffler
14	813280328	Nipple Pipe 3/8 Npt X 3-1/2
15	813200300	Elbow Std 90 Degree 3/8-18 Npt
16	811050500	Washer Lock Ext Tooth 5/16
23	532159880	Shield Browning/Debris Guard
29	532137180	Kit Spark Arrestor (Flat Scrn)
31	532161911	Tank Fuel Front 2 00 Gal Nat
32	532140527	Cap Asm Fuel W/sym Vented
33	532123487	Clamp Hose Black
35	817490512	Screw
37	532137040	Line Fuel 20"
38	-----	Plug Oil Drain (Order From Engine Manufacturer)
40	532124028	Bushing Snap Nyl Blk Fuel Line
44	817490412	Screw Hexwsh Thdrol 1/4-20x3/4
46	819091416	Washer 9/32 X 7/8 X 16 Ga
62	810040500	Washer Lock Hvy Hlcl Spr 5/16
77	819101216	Washer 5/16 x 3/4 x 16 Ga.
79	532125398	Bolt Hex
80	874760508	Bolt Hex Hd 5/16-18 UNC x 1/2
81	532128861	Nut Flange 1/4-20 Starter Nut

**NOTE:** All component dimensions given in U.S. inches  
1 inch = 25.4 mm



# REPAIR PARTS

TRACTOR - MODEL NO. LTH130 (954140005F), PRODUCT NO. 954 14 00-05

## MOWER DECK

KEY NO.	PART NO.	DESCRIPTION	KEY NO.	PART NO.	DESCRIPTION
1	532162809	Deck Weldment Mower 42" W/Adj	58	532131950	Spring Ext Elect CL 38 & 42" Deck
2	872140506	Bolt Rdhd Sqnk 5/16-18unc X3/4	59	532141043	Guard, Belt
3	532138017	Bracket Asm Fr Sway Bar 38/42	61	532131950	Spring Ext. Elect
4	532138440	Bracket Asm Deck 42"sway Bar	68	532144959	V-Belt Mower
5	532124670	Retainer Spring	83	532120958	Washer Sintered
6	532130832	Arm Suspension Rear	84	532156084	Keeper 'Belt Idler
8	532850857	Bolt 3/8-24x1 25 Gr8 Patched	85	872140618	Bolt Carriage 3/8-16 x 2-1/4 Gr.5
9	810030600	Washer Lock Hvy 3/8 Unplated	90	874760616	Bolt Fin Hex 3/8-16unc X 1
10	532140296	Washer Hard Blade Mower Vented	91	532132274	Bracket Asm Noseroller LH
11	532134149	Blade Mower Mulching 42"	92	873800600	Nut Lock Hex w/ins. 3/8-16 UNC
12	532129895	Bearing Ball #6204 (Mandrel)	93	819171416	Washer 17/32 X 7/8 X 16 Ga
13	532137645	Shaft Asm W/lower Bearing	94	532132264	Roller Nose 38 & 42
14	532128774	Housing Mandrel Vented(machd)	95	532132273	Bracket Asm Noseroller RH
15	532110485	Bearing Ball Mandrel	101	532136420	Cover Mulching 42" Blk
16	532140329	Stripper Round Mower	102	871161010	Screw
17	872110618	Bolt Rdhd Sqnk 3/8-16 X 2-1/4	103	819061216	Washer #10
18	872140505	Bolt Carr 5/16-18 X 5/8	104	810071000	Washer Lock #10
19	532132827	Bolt Shoulder	105	532160793	Latch Asm Bagger
20	532159770	Baffle Vortex 42	106	532125004	Nut Weld .327/.304 #10-24
21	873680500	Nut Crown Lock 5/16-18	116	532137644	Bolt Shld
22	532134753	Stiffener Bracket 42"deck	117	532133957	Wheel Gauge blk.
23	532131267	Bracket Deflector Mower 42"	118	873930600	Nut Centerlock 3/8 - 16 UNC
24	532105304	Cap Sleeve 80x 112 Blk Mower	119	819121414	Washer 3/8 x 7/8 x 14 Ga.
25	532123713	Spring Torsion Deflector 2 52	125	876020816	Cotter Pin
26	532110452	Nut Push Phos & Oil	128	532153390	Washer Felt
27	532130968	Shield Deflector Mower 42" Blk	130	874780616	Bolt Fin Hex 3/8-16 UNC x 1 Gr. 5
28	819111016	Washer 11/32 X 5/8 X 16 Ga	132	819132203	Washer 13/32 x 1-3/8 x 3 Ga
29	532131491	Rod Hinge 42"6 75 Wlg	133	872110622	Bolt Rdhd 3/8-16 UNC x 2-3/4 Gr.5
30	532157722	Screw Thdrol Washer Head	134	532156941	Pin Head Rivet
31	532129963	Washer Spacer Mower Vented	135	532159765	Bracket Asm Whl Ga Rear LH 42"
32	532153535	Pulley Mandrel 42"	136	532162648	Bar Pnt Adjusting Wheel Gauge
33	532137266	Nut 9/16top Lock Fling Cntr	137	872110505	Bolt Carr 5/16-18 x 5/8 Short
35	532133835	Fastner Christmas Tree	138	532159763	Bracket Asm Whl Ga. Rear RH 42"
36	532131494	Pulley Idler Flat 3 060	139	532159767	Bracket Asm Whl Ga. Front RH 42"
37	819131316	Washer 13/32 X 13/16 X 16 Ga	140	532159768	Bracket Asm Whl Ga. Front RH 42"
38	532132823	Spacer Spring Stop Idler	--	532162859	Deck Serv 42" Elec Vent (Standard Deck - Order Nose Roller, Gauge Wheel and Mulcher Plate components separately Key Nos. 90-95, 101-106 and 111-121)
40	873680600	Nut Lock 3/8-16 Unc	--	532130794	Mandrel Assembly (Includes Key Numbers 8-10, 12-15, 31 and 33)
44	532140088	Guard Mandrel LH Black			
46	532137729	Screw Thdrol 1/4-20x5/8			
54	532133943	Washer Hardened			
55	532140084	Arm Idler 42"mower LT/YT			
56	532122052	Spacer Retainer Pm Mower			

# REPAIR PARTS

TRACTOR - MODEL NO. LTH130 (954140005F), PRODUCT NO. 954 14 00-05

MOWER LIFT

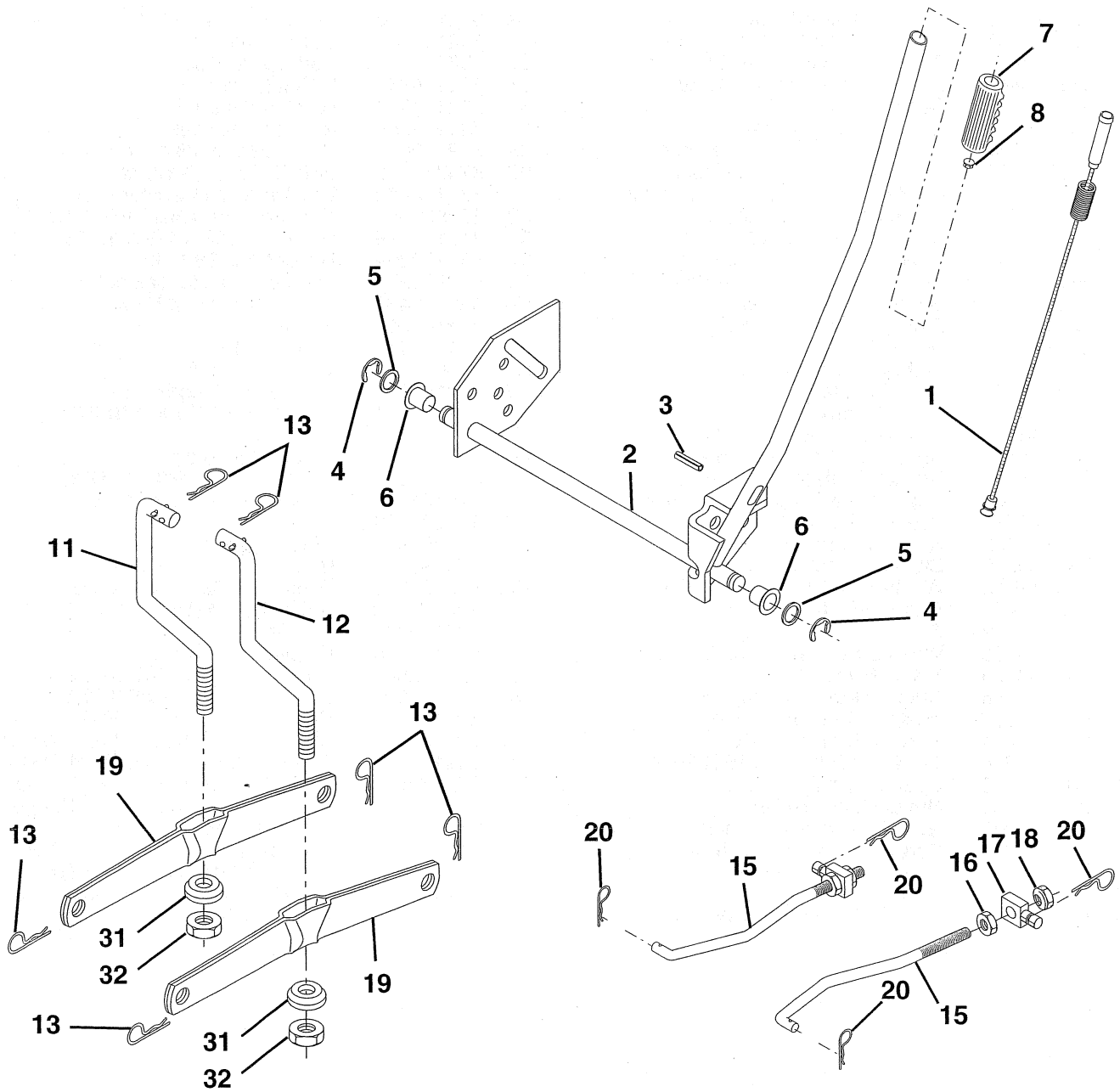



# REPAIR PARTS

TRACTOR - MODEL NO. LTH130 (954140005F), PRODUCT NO. 954 14 00-05

## MOWER LIFT

KEY NO.	PART NO.	DESCRIPTION
1	532159460	Wire Asm Inner W/plunger
2	532159471	Shaft Asm Lift
3	532105767	Pin Groove
4	812000002	E Ring #5133-62
5	819211621	Washer PLTD 21/32 X 1 X 21ga
6	532120183	Bearing Nylon Blk 629 Id
7	532109413	Grip Handle Bicycle
8	532124526	Button Plunger Black
11	532139865	Link Lift LH
12	532139866	Link Lift RH
13	532124670	Retainer Spring
15	532127218	Link Front
16	873350800	Nut Jam Hex 1/2-13 Unc
17	532130171	Trunnion Blk Zinc
18	873800800	Nut Lock W/wsh 1/2-13unc
19	532139868	Arm Suspension Rear
20	532124660	Spring, Retainer
31	532140302	Bearing Pvt. Lift Spherical
32	873540600	Nut Crownlock 3/8-24

**NOTE:** All component dimensions given in U.S. inches  
1 inch = 25.4 mm

# REPAIR PARTS

TRACTOR - MODEL NO. LTH130 (954140005F), PRODUCT NO. 954 14 00-05  
HYDRO GEAR TRANSAXLE - MODEL NUMBER 310-0500

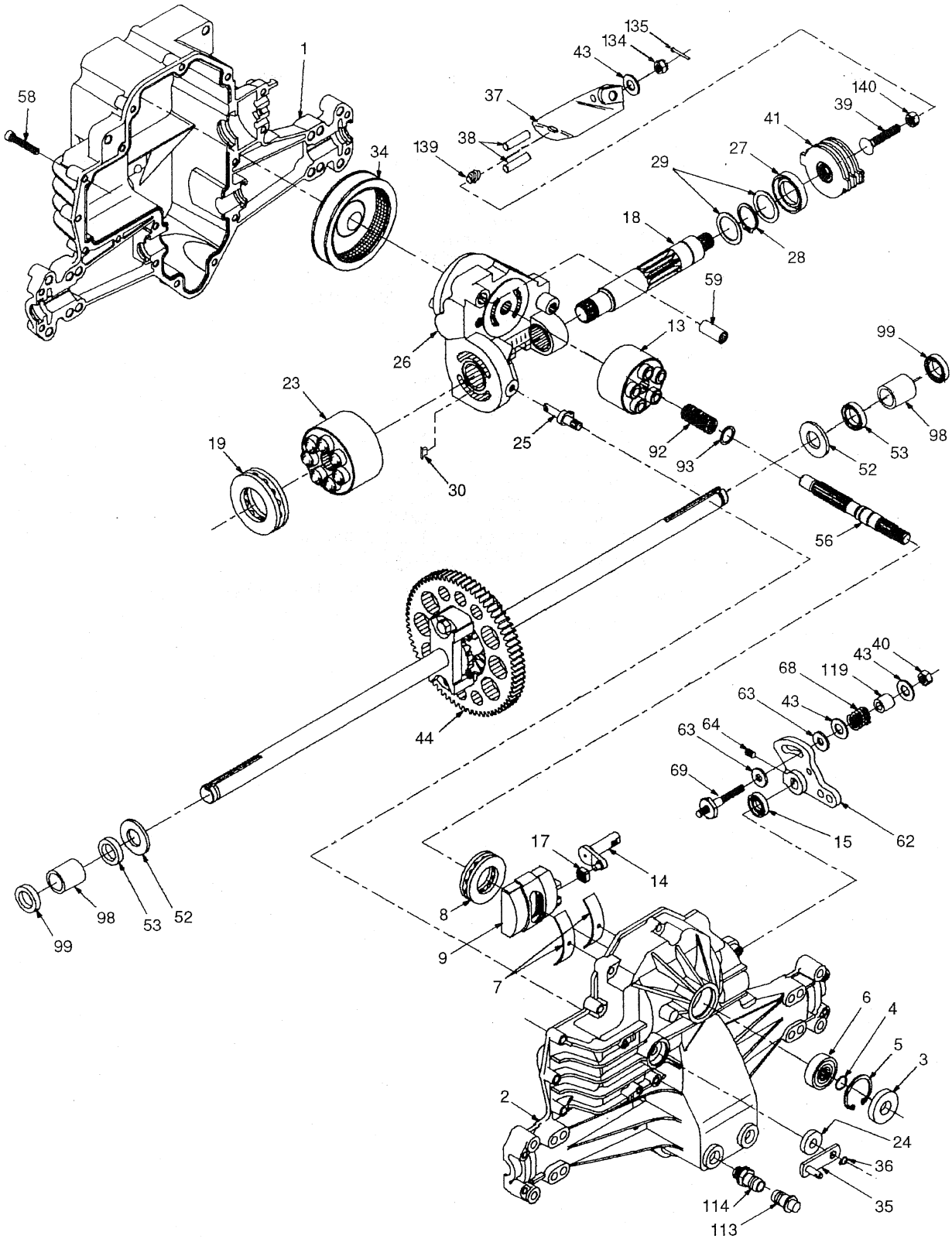

# REPAIR PARTS

TRACTOR - MODEL NO. LTH130 (954140005F), PRODUCT NO. 954 14 00-05

## HYDRO GEAR TRANSAXLE - MODEL NUMBER 310-0500

KEY PART NO. NO.	DESCRIPTION	KEY PART NO. NO.	DESCRIPTION
1 142986	Housing, Lower	40 150778	Locknut, Hex 5/16-24 UNJC
2 142987	Assembly, Upper Housing	41 142958	Brake Rotor/Stator Kit
3 142932	Seal, Lip	43 142884	Washer 7/16 x 7/8 x .060
4 142928	Ring, Wire Retaining	44 142990	Differential Assembly
5 142933	Ring, Retaining	52 142991	Washer 3/4 x 1.5 x .13
6 142934	Bearing, Shaft Ball	53 142961	Seal .75 x 1.25 x .250
7 142935	Bearing, Cradle	56 142963	Shaft, Input
8 150771	Bearing, Thrust 30 x 52 x 13	58 142964	Bolt 1/4-20 x 1.38
9 142937	Swashplate, Variable	59 142965	Pin .5 OD x .43 ID x .750
13 142938	Block, Cylinder Assembly	62 142966	Arm, Control
14 142939	Arm, Trunnion	63 142967	Puck, Dampener
15 142940	Seal, Lip	64 142920	Set Screw
17 142941	Guide, Slot	68 142969	Spring
18 150772	Shaft, Motor	69 144610	Stud 5/16-24
19 150773	Bearing, Thrust 42 x 68 x 16	92 142977	Spring, Block
23 142944	Block, Cylinder Assembly	93 142978	Washer, Block Thrust
24 142945	Seal, Lip 10 x 25 x 7	98 142993	Sleeve Bearing
25 142946	Actuator, Bypass	99 142976	Seal, Wiper
26 150774	Center Section Assembly Kit	113 142917	Cap, Vent Assembly
27 142948	Seal, Lip 26 x 42 x 8	114 142918	Fitting, O-Ring Assembly
28 142949	Ring, Retaining	119 142980	Spacer
29 142950	Washer 26 x 35 x 1	134 144607	Nut, Castle 5/16-24
30 150787	Nut, Jam	135 144608	Pin, Cotter
34 142951	Oil Filter Element	139 150775	Spring, Compression
35 142952	Arm, Bypass	140 150776	Nut, Hex 5/16-24
36 142953	Ring, Retaining		
37 142954	Arm, Actuating		
38 142955	Pin, Actuating		
39 150777	Bolt 5/16-24 x 1-3/4		

**NOTE:** All component dimensions given in U.S. inches  
1 inch = 25.4 mm

---

# NOTES

---

---

# NOTES

---

# SUGGESTED GUIDE FOR SIGHTING SLOPES FOR SAFE OPERATION

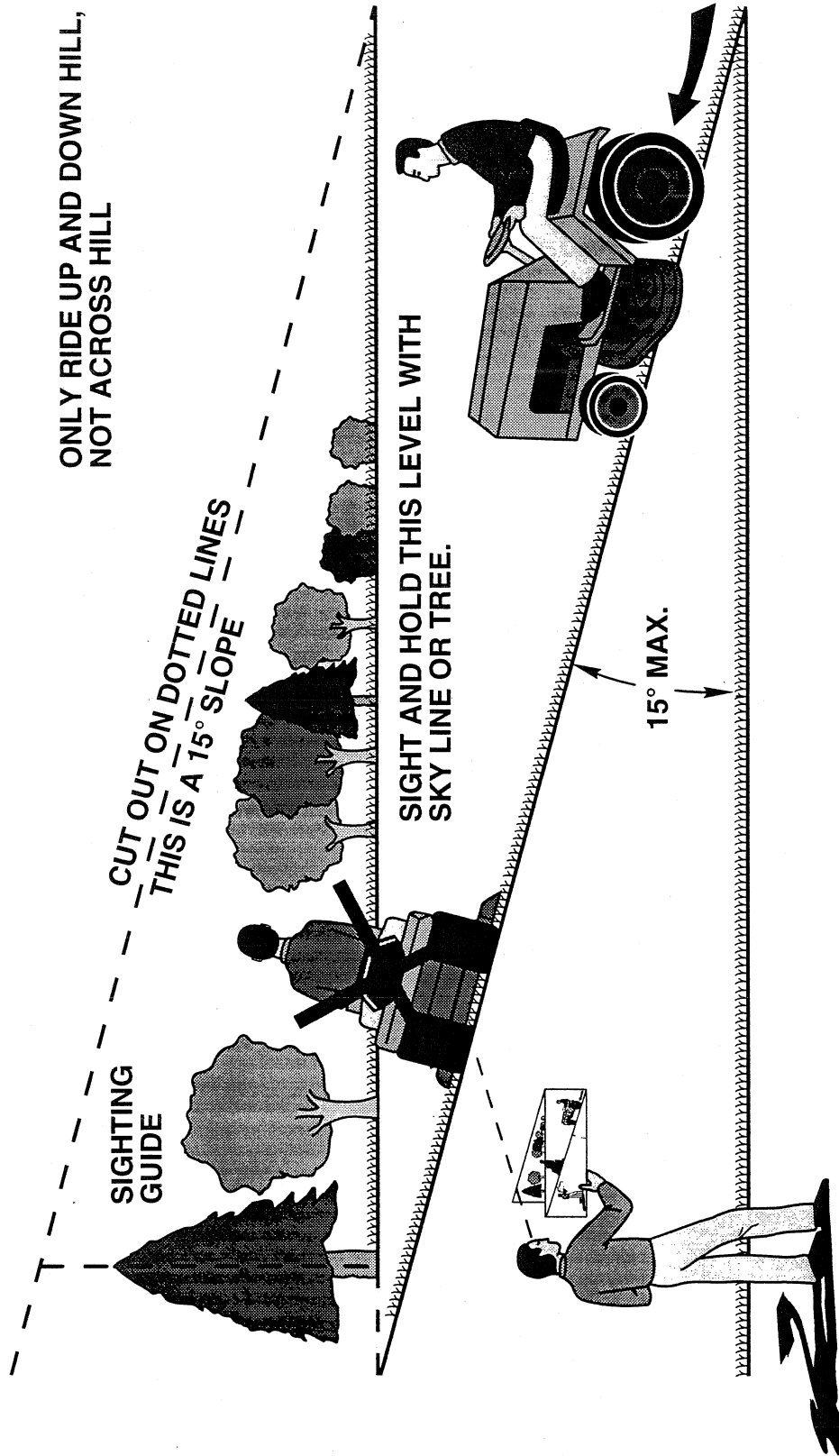

Operate your Tractor up and down the face of slopes (not greater than 15°), never across the face. Make turns gradually to prevent tipping or loss of control. Exercise extreme caution when changing direction on slopes.





## WARRANTY STATEMENT

### SECTION 1: LIMITED WARRANTY

Husqvarna Forest & Garden Company ("Husqvarna") warrants Husqvarna product to the original purchaser to be free from defects in material and workmanship from the date of purchase for the "Warranty Period" of the product as set forth below:

**Lifetime Warranty:** All tiller lines, trimmer shafts, ignition coils and modules on hand held product.

**2 Year Warranty:** Riding lawn mowers, yard and garden tractors, walk behind mowers, tillers, trimmers, brushcutters, snow blowers, handheld blowers, hedge-, trimmers, and electrical products for noncommercial, nonprofessional, noninstitutional or nonincome producing use, except as herein stated.

Emission control system components necessary to comply with CARB-95 and EPA regulations, except for those components which are part of engine systems manufactured by third party engine manufacturers for which the purchaser has received a separate warranty with product information supplied at time of purchase.

**1 Year Warranty:** Chain saws, clearing saws and backpack blowers for noncommercial, nonprofessional, noninstitutional or nonincome producing use. Trimmer models 120, 125, 122, 132, 225, 232 and 235 used for commercial purposes.

**90 Day Warranty:** Any Husqvarna product used for rental, commercial, institutional, professional or income producing use except as otherwise provided herein.

**30 Day Warranty:** Husqvarna bow guide and replacement parts.

### SECTION 2: HUSQVARNA'S OBLIGATIONS UNDER THE WARRANTY

Husqvarna will repair or replace defective components without charge for parts or labor if a component fails because of a defect in material or workmanship during the warranty period.

### SECTION 3: ITEMS NOT COVERED BY THIS WARRANTY

The following items are not covered by this warranty:

- (1) Normal customer maintenance items which become worn through normal regular use, including, but not limited to, belts, blades, blade adapters, bulbs, filters, guide bars, lubricants, rewind springs, saw chain, spark plugs, starter ropes and tines;
- (2) Natural discoloration of material due to ultraviolet light;
- (3) Engine and drive systems not manufactured by Husqvarna; these items are covered by the respective manufacturer's warranty as provided in writing with the product information supplied at the time of purchase; all claims must be sent to the appropriate manufacturer;
- (4) Lawn and garden attachments are covered by a third party which gives a warranty, all claims for warranty should be sent to the manufacturer; and
- (5) Emission Control System components necessary to comply with CARB-95 and EPA regulations which are manufactured by third party engine manufacturer.

### SECTION 4: EXCEPTIONS AND LIMITATIONS

This warranty shall be inapplicable to defects resulting from the following:

- (1) Accident, abuse, misuse, negligence and neglect, including stale fuel, dirt, abrasives, moisture, rust, corrosion, or any adverse reaction due to incorrect storage or use habits;

- (2) Failure to operate or maintain the unit in accordance with the Owner's/Operator's manual or instruction sheet furnished by Husqvarna;
- (3) Alterations or modifications that change the intended use of the product or affects the product's performance, operation, safety, or durability, or causes the product to fail to comply with any applicable laws; or;
- (4) Additional damage to parts or components due to continued use occurring after any of the above.

**REPAIR OR REPLACEMENT AS PROVIDED UNDER THIS WARRANTY IS THE EXCLUSIVE REMEDY OF THE PURCHASER. HUSQVARNA SHALL NOT BE LIABLE FOR ANY INCIDENTAL OR CONSEQUENTIAL DAMAGES FOR BREACH OF ANY EXPRESS OR IMPLIED WARRANTY ON THESE PRODUCTS EXCEPT TO THE EXTENT PROHIBITED BY APPLICABLE LAW. ANY IMPLIED WARRANTY OF MERCHANTABILITY OR FITNESS FOR A PARTICULAR PURPOSE ON THESE PRODUCTS IS LIMITED IN DURATION TO THE WARRANTY PERIOD AS DEFINED IN THE LIMITED WARRANTY STATEMENT. HUSQVARNA RESERVES THE RIGHT TO CHANGE OR IMPROVE THE DESIGN OF THE PRODUCT WITHOUT NOTICE, AND DOES NOT ASSUME OBLIGATION TO UPDATE PREVIOUSLY MANUFACTURED PRODUCTS.**

Some states do not allow the exclusion of incidental or consequential damages, or limitations on how long an implied warranty lasts, so the above limitations or exclusions may not apply to you. This warranty gives you specific legal rights, and you may also have other rights which vary from state to state.

### SECTION 5: CUSTOMER RESPONSIBILITIES

The product must exhibit reasonable care, maintenance, operation, storage and general upkeep as written in the maintenance section of the Owner's/Operator's manual. Should an operational problem or failure occur, the product should not be used, but delivered as is to an authorized Husqvarna dealer for evaluation. Proof of purchase, as explained in section 6, rests solely with the customer.

### SECTION 6: PROCEDURE TO OBTAIN WARRANTY CONSIDERATION

It is the Owner's and Dealer's responsibility to make certain that the Warranty Registration Card is properly filled out and mailed to Husqvarna Forest & Garden Company. This card should be mailed within ten (10) days from the date of purchase in order to confirm the warranty and to facilitate post-sale service.

Proof of purchase must be presented to the authorized Husqvarna dealer in order to obtain warranty service. This proof must include date purchased, model number, serial number, and complete name and address of the selling dealer.

To obtain the benefit of this warranty, the product believed to be defective must be delivered to an authorized Husqvarna dealer in a timely manner, no later than thirty (30) days from date of the operational problem or failure. The product must be delivered at the owner's expense. Pick-up and delivery charges are not covered by this warranty. An authorized Husqvarna dealer can be normally located through the "Yellow Pages" of the local telephone directory or by calling 1-800-HUSKY62 for a dealer in your area.

**HUSQVARNA FOREST & GARDEN COMPANY  
9006-J PERIMETER WOODS DRIVE  
CHARLOTTE, NC 28216**

Husqvarna  
532164804

02.05.98 JH

Printed in U.S.A.