

GARDENA Automatikventil 1060 U (bis Bj. 2001)
 Automatikventil 2060 U (bis Bj. 2001)
 Bewässerungsventil V1 (bis Bj. 2002)
 Bewässerungsventil V2 (bis Bj. 2002)

Art.-Nr. 1241
 Art.-Nr. 1240
 Art.-Nr. 1252
 Art.-Nr. 1253

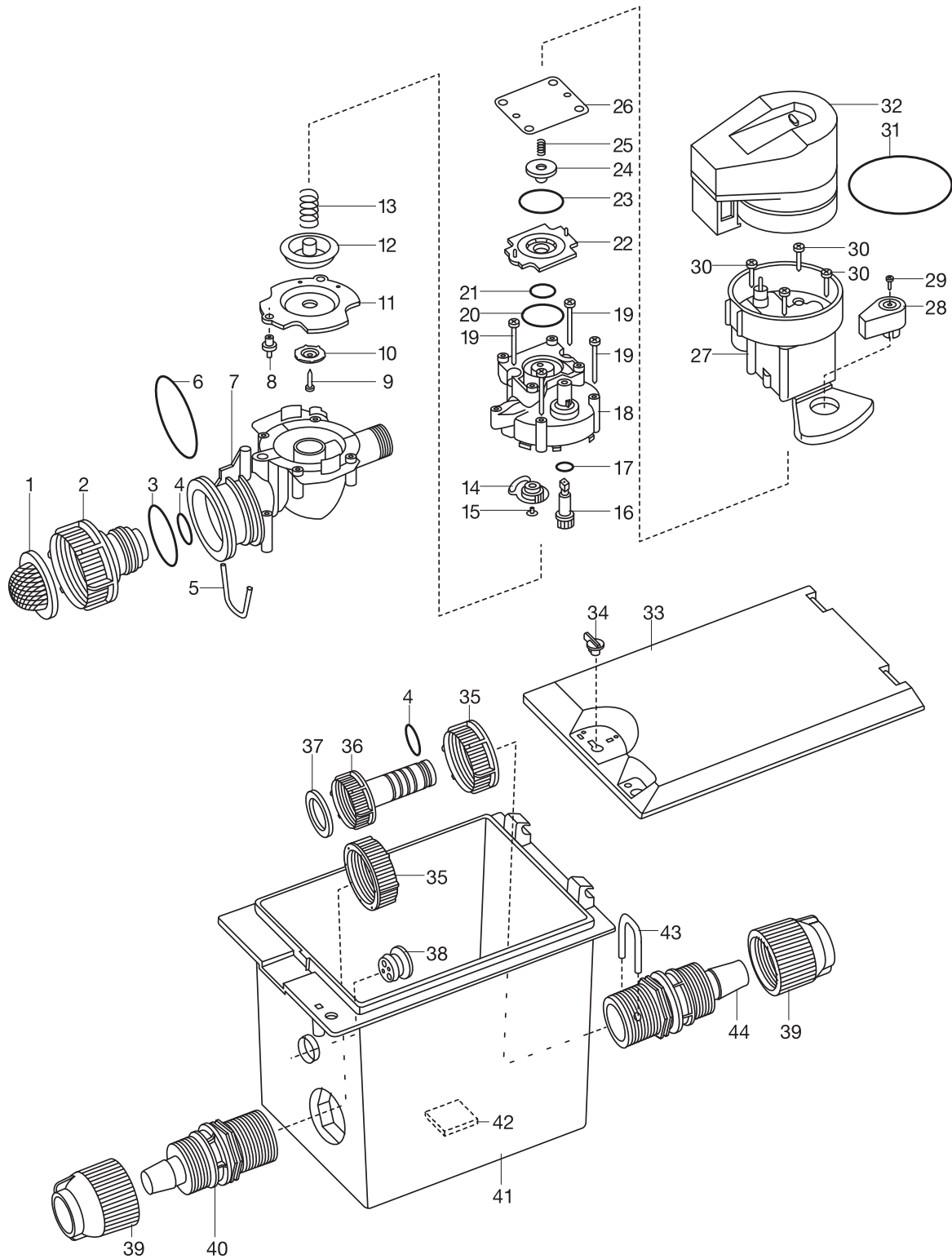

Bild Nr. Picture No.	Ersatzteil-Nr. Spare Part No.	Bezeichnung	Description	Désignation
Art. 1252		Bewässerungsventil V 1 - 3/4" bis Baujahr 2002	Watering Valve with Box VB 1 - 3/4" until 2002	Bloc-vanne 1 voie - 3/4" jusqu'à 2002
Art. 1241		Automatikventil 1060 U - 3/4" bis Baujahr 2001	Automatic Valve 1060 U - 3/4" until 2001	Bloc-vanne programmable 1060 U - 3/4" jusqu'à 2001
1	1815-00.614.00	Sieb, vollst.	Filter, cpl.	Filtre, cpl.
2	1210-00.600.61	Anschlusschülse	Conductor barrel	Douille de raccord
3	1192-00.600.01	O-Ring 20,5x3,2	O-ring 20,5x3,2	Joint torique 20,5x3,2
4	964-00.505.04	O-Ring 18,4x2,7	O-ring 18,4x2,7	Joint torique 18,4x2,7
5	1210-00.600.52	Klammer	Clamp	Clip de fixation
6	1940-00.610.18	O-Ring 40x2,5	O-ring 40x2,5	Joint torique 40x2,5
2-7	1174-00.521.00	Ventilkörper, vollst.	Valve body, cpl.	Corps de soupape, cpl.
8	1815-00.610.27	Steuerdüse rot	Control nozzle rot	Buse de commande rouge
9	882-00.007.11	Blechschaube 3,5x13-F-H	Sheet metal screw 3,5x13-F-H	Vis à tôle 3,5x13-F-H
10	1174-00.612.03	Stützkegel, rot	Support cone, red	Cone of support, rouge
11	1174-00.662.01	Membrane	Diaphragm	Diaphragme
12	1174-00.612.02	Membranflansch, rot	Diaphragm flange, red	Flanc de diaphragme, rouge
13	1174-00.610.08	Druckfeder, groß	Pressure spring, large	Ressort de pression, grand
14-18	1240-00.615.00	Ventildeckel, kpl.	Valve cover, cpl.	Couvercle de soupape, cpl.
19	1182-00.600.02	Blechschaube 4,2x38-C-H	Sheet metal screw 4,2x38-C-H	Vis à tôle 4,2x38-C-H
20	1174-00.610.05	O-Ring 18,72x2,62	O-ring 18,72x2,62	Joint torique 18,72x2,62
21	900-00.101.06	O-Ring 10,5x2,7	O-ring 10,5x2,7	Joint torique 10,5x2,7
22	1174-00.610.03	Ventilplatte	Valve plate	Support de clapet
23	1672-00.600.11	O-Ring 24x2	O-ring 24x2	Joint torique 24x2
24	1174-00.618.00	Magnetplatte, vollst.	Magnetic plate, cpl.	Clapet magnétique, cpl.
25	1174-00.610.11	Druckfeder, klein	Pressure spring, small	Ressort de pression, petit
26	1174-00.610.04	Abdeckfolie	Cover foil	Protège-contact
28	1599-00.600.12	Hebel	Lever	Levier
29	1599-00.600.17	Blechschaube 2,2x9,5-C-H	Sheet metal screw 2,2x9,5-C-H	Vis à tôle 2,2x9,5-C-H
1-30	1240-00.610.00	Magnetventil, vollst.	Solenoid valve, cpl.	Electrovanne, cpl.
31	1182-00.620.13	O-Ring 48,9x2,62	O-ring 48,9x2,62	Joint torique 48,9x2,62
32,31	1240-00.620.00	Steuereinheit, vollst. (Art. 1250-20)	Control unit, cpl. (Art. 1250-20)	Module de commande, cpl. (Réf. 1250-20)
33	1241-00.600.06	Deckel	Cover	Couvercle
34	1594-00.600.51	Drehknopf	Turning knob	Bouton rotatif
35x	3815-00.600.06	Mutter, hellgrau	Nut, light grey	Écrou, gris clair
36x o	1240-00.600.16	Ausgleichrohr	Compensation tube	Tuyau de compensation
37x o	1121-00.000.01	Flachdichtung 25,1/16x3	Washer 25,1/16x3	Joint plat 25,1/16x3
38x	1255-00.600.40	Kabelklemme	Cable clip	Bouchon passe-fils
39x	1240-00.600.26	Klemmmutter 3/4"	Lock nut 3/4"	Écrou de serrage 3/4"
40x	1240-00.600.11	Anschlussrohr	Joining pipe	Tuyau de raccordement
42	1240-00.600.31	Vlies	Fleece	Feutre
43x	1240-00.600.41	Bügel	Bow	Clips
44x	1240-00.600.36	Anschlussrohr (2 Löcher)	Joining pipe (2 hole)	Tuyau de raccordement (2 trous)
x	1240-00.600.21	Spülrohr	Connecting tube	Tube de connexion
x	1122-00.000.01	Flachdichtung 31,3x3	Washer 31,3x3	Joint plat 31,3x3
x	1240-00.600.42	Fettbeutel	Fat bag	Sac avec graisse
x	803-00.611.00	Endkappe, vollst. 3/4" hellgrau	End cap, cpl. 3/4" light grey	Bouchon terminal, cpl. 3/4" gris clair
	1240-00.702.00	Polybeutel, kpl.	Accessory bag, cpl.	Sachet d'accessoires, cpl.
		x = Teile im Zubehörbeutel enthalten.	x = All parts in the accessory bag included.	x = Pièces incluses dans le sachet d'accessoires.
		o = Beide Teile zusammen liefern.	o = Deliver both parts together.	o = Livrer ensemble toutes deux pièces.
Art. 1253		Bewässerungsventil V 2 - 3/4" bis Baujahr 2002	Watering Valve with Box VB 2 - 3/4" until 2002	Bloc-vanne 2 voies - 3/4" jusqu'à 2002
Art. 1240		Automatikventil 2060 U - 3/4" bis Baujahr 2001	Automatic Valve 2060 U - 3/4" until 2001	Bloc-vanne programmable 2060 U - 3/4" jusqu'à 2001
33	1240-00.600.06	Deckel	Cover	Couvercle
		Alle anderen Ersatzteile wie bei Art. 1241/1252	All other spare parts see art. 1241/1252	Pour toutes les autres pièces, voir réf. 1241/1252
	1308-00.900.01	Adapterkabel vollst. 1303-1240	Adapter cpl. for 1303-1240	Câble d'adaptation cpl. pour 1303-1240
		Nur die aufgeführten Teile sind lieferbar!	Only the mentioned spare parts are available!	Seules les pièces indiquées sont disponibles!