

GARDENA Tiefbrunnenpumpe 5500/5 inox
 Tiefbrunnenpumpe 6000/5 inox
 Tiefbrunnenpumpe 6000/5 inox automatic

Art.-Nr. 1489
 Art.-Nr. 1492
 Art.-Nr. 1499

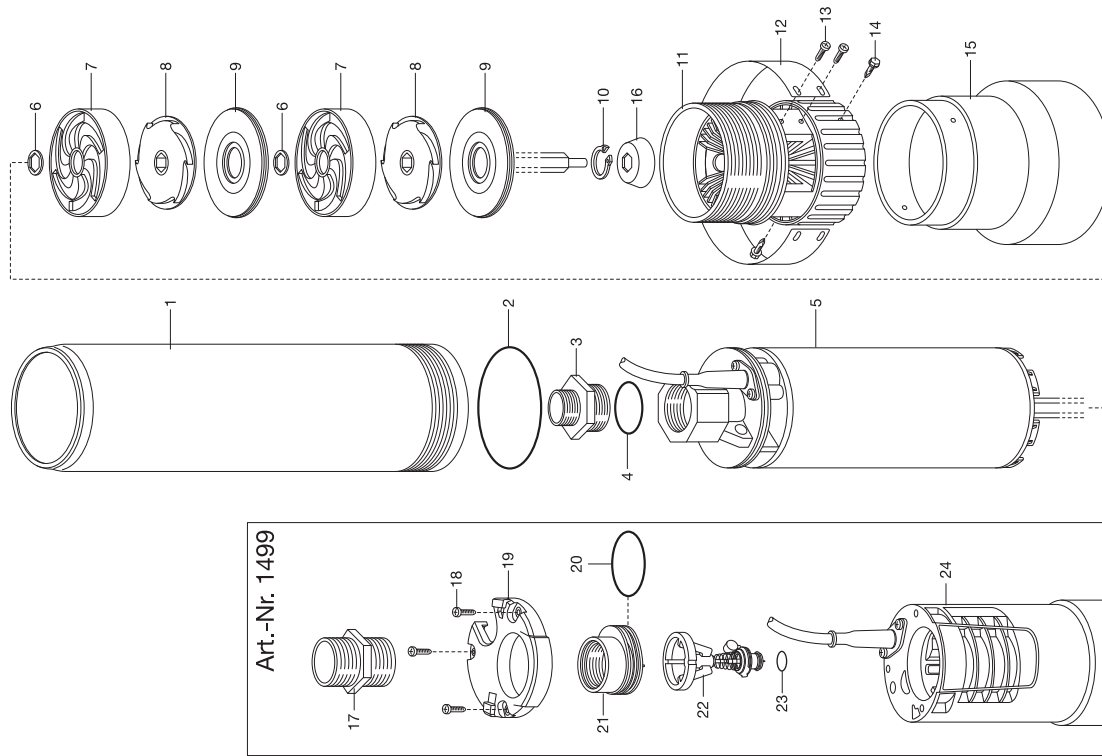

GARDENA Tauch-Druckpumpe 6000/3 S
 Tauch-Druckpumpe 6000/5 S

Art.-Nr. 1469
 Art.-Nr. 1473

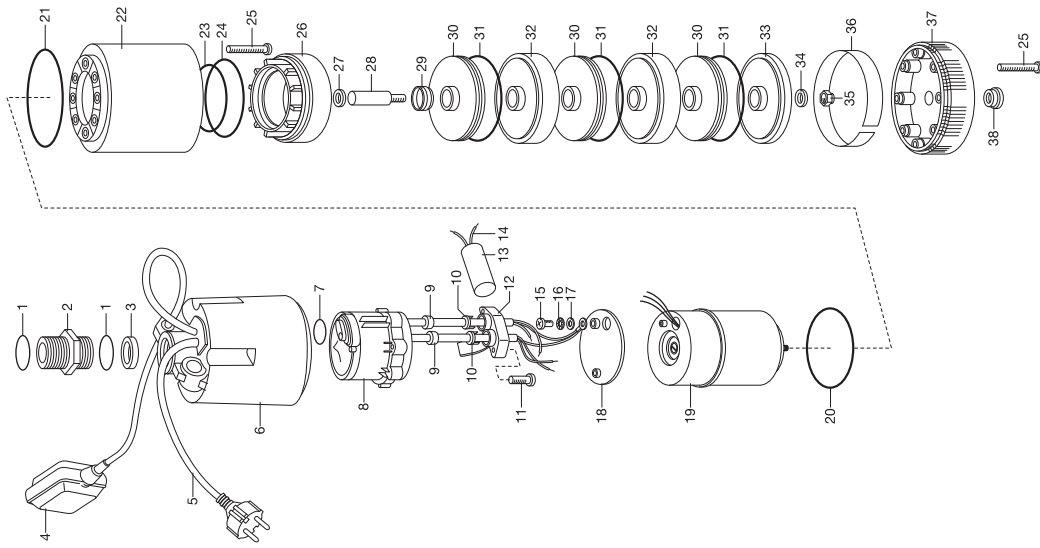

Bild Nr. Picture No.	Ersatzteil-Nr. Spare Part No.	Bezeichnung	Description	Désignation
Art. 1469 Art. 1473		Tauch-Druckpumpe 6000/3 S Tauch-Druckpumpe 6000/5 S <u>bis Baujahr 2009</u>	Submersible Pressure Pump Submersible Pressure Pump 6000/5 S <u>until 2009</u>	Pompe immergée pour arrosage 6000/3 S Pompe immergée pour arrosage 6000/5 S <u>jusqu'à 2009</u>
1	1743-00.900.02	O-Ring 1"	O-ring 1"	Joint torique 1"
2,1	1745-00.701.00	Anschlusstück 1" - 1"	Connector 1" - 1"	Pièce de raccordement 1" - 1"
3	1469-00.900.01	Absperrklappe	Shut-off flap	Clapet d'arrêt
23	1469-00.900.10	O-Ring 95x2	O-ring 95x2	Joint torique 95x2
24	1469-00.900.11	O-Ring 110x4	O-ring 110x4	Joint torique 110x4
25	1469-00.900.12	Schraube 4,7x65	Screw 4,7x65	Vis 4,7x65
29	1469-00.900.16	Dichtung	Washer	Joint
30	1469-00.900.17	Turbine	Turbine	Turbine
31	1469-00.900.18	O-Ring 113x1	O-ring 113x1	Joint torique 113x1
32	1469-00.900.19	Turbinaufnahme	Turbine admission	Logement de turbine
33	1469-00.900.20	Abschlussdeckel	End cover	Couvercle
34	1469-00.900.21	Scheibe Innox	Disc Innox	Disque Innox
35	1430-00.000.50	Sechskantmutter M8x1-8	Hexagonal nut M8x1-8	Écrou hexagonal M8x1-8
37	1469-00.900.24	Saugfuß	Suction foot	Pied d'aspiration
Art. 1474		Tiefbrunnenpumpe 4000/6 Innox <u>bis Baujahr 2009</u>	Deep Well Pump 4000/6 Innox <u>until 2009</u>	Pompe immergée de forage 4000/6 Innox <u>jusqu'à 2009</u>
	1474-00.600.01	Feinfilter	Fine filter	Filtre fin
	1474-00.900.01	# Kondensator 25µF	Capacitor 25µF	Condensateur 25µF
	1474-00.900.05	Fuß	Base	Pied en fonte
	1478-00.610.00	Seil, 15 mtr.	Cord, 15 m	Corde, 15 m
Art. 1478		Tauch-Druckpumpe 4000/6 Innox <u>bis Baujahr 2001</u>	Submers. Pressure Pump 4000/6 Innox <u>until 2001</u>	Pompe immergée pour arrosage 4000/6 Innox <u>jusqu'à 2001</u>
	1478-00.900.03	# Kondensator 12,5 µF	Capacitor 12,5 µF	Condensateur 12,5 µF
	1478-00.900.04	# Steckergehäuse	Connector shell	Carter de commande
	2546-00.600.28	Blechschrabe 4,2x19-C-H	Sheet metal screw 4,2x19-C-H	Vis à tôle 4,2x19-C-H
	1745-00.701.00	Anschlusstück 1" - 1"	Connector 1" - 1"	Pièce de raccordement 1" - 1"
	1743-00.900.02	O-Ring 1"	O-ring 1"	Joint torique 1"
	1478-00.900.13	Feinfilter	Fine filter	Filtre fin
	1478-00.900.14	Pumpenfuß	Pump foot	Pied de pompe
	1478-00.610.00	Seil, 15 mtr.	Cord, 15 m	Corde, 15 m
Art. 1479		Tauch-Druckpumpe 4000/5 Innox <u>bis Baujahr 2009</u>	Submers. Pressure Pump 4000/5 Innox <u>until 2009</u>	Pompe immergée pour Arrosage 4000/5 Innox <u>jusqu'à 2009</u>
	1745-00.701.00	Anschlusstück 1" - 1"	Connector 1" - 1"	Pièce de raccordement 1" - 1"
	1478-00.900.13	Feinfilter	Fine filter	Filtre fin
	1478-00.900.14	Pumpenfuß	Pump foot	Pied de pompe
	1478-00.610.00	Seil, 15 mtr.	Cord, 15 m	Corde, 15 m
Art. 1489 Art. 1492		Premium Tiefbrunnenp. 5500/5 innox Premium Tiefbrunnenp. 6000/5 innox	Premium Deep Well Pump 5500/5 innox Premium Deep Well Pump 6000/5 innox	Pompe imm. de forage 5500/5 innox Premium Pompe imm. de forage 6000/5 innox Premium
3,4	1489-00.900.01	Anschlusstück 1 1/4"	Connector 1 1/4"	Pièce de raccordement 1 1/4"
6	1489-00.900.02	Dichtscheibe	Gasket	Joint plat
7	1489-00.900.03	Turbinengehäuse	Turbine casing	Carter de turbine
8	1489-00.900.04	Turbine	Turbine	Turbine
9	1489-00.900.05	Turbinengehäusedeckel	Turbine casing cover	Couvercle de carter de turbine
10	1489-00.900.06	Sicherungsring	Locking ring	Circlip
11	1489-00.900.07	Pumpenfuß	Pump foot	Pied de pompe
12	1489-00.900.08	Filtersieb	Filter	Filtre
13	4200-00.600.27	Blechschrabe 4,2x9,5-F-H	Sheet metal screw 4,2x9,5-F-H	Vis à tôle 4,2x9,5-F-H
14	1489-00.900.09	Schraube	Screw	Vis
15	1489-00.900.10	Standfuß	Base	Pied en fonte
16	1489-00.900.11	Dichtung	Washer	Joint
	1489-00.900.12	Seil, 22 mtr.	Cord, 22 m	Corde, 22 m
Art. 1499		Premium Tiefbrunnenpumpe 6000/5 innox automatic	Premium Deep Well Pump 6000/5 innox automatic	Pompe immergée de forage 6000/5 innox automatic Premium
3,4	1489-00.900.01	Anschlusstück 1 1/4"	Connector 1 1/4"	Pièce de raccordement 1 1/4"
6	1489-00.900.02	Dichtscheibe	Gasket	Joint plat
7	1489-00.900.03	Turbinengehäuse	Turbine casing	Carter de turbine
8	1489-00.900.04	Turbine	Turbine	Turbine
9	1489-00.900.05	Turbinengehäusedeckel	Turbine casing cover	Couvercle de carter de turbine
10	1489-00.900.06	Sicherungsring	Locking ring	Circlip
11	1489-00.900.07	Pumpenfuß	Pump foot	Pied de pompe
12	1489-00.900.08	Filtersieb	Filter	Filtre
13	4200-00.600.27	Blechschrabe 4,2x9,5-F-H	Sheet metal screw 4,2x9,5-F-H	Vis à tôle 4,2x9,5-F-H
14	1489-00.900.09	Schraube	Screw	Vis
15	1489-00.900.10	Standfuß	Base	Pied en fonte
16	1489-00.900.11	Dichtung	Washer	Joint
17	1745-00.701.00	Anschlusstück 1" - 1"	Connector 1" - 1"	Pièce de raccordement 1" - 1"
18	1499-00.900.01	Torxschraube	Screw Torx	Vis Torx
19	1499-00.900.02	Deckel	Cover	Couvercle
20	1499-00.900.03	O-Ring	O-ring	Joint torique
21	1499-00.900.04	Ventildeckel	Valve cover	Couvercle de soupape
22,23	1499-00.900.05	Rückschlagventil	Non-return valve	Clapet anti-retour
23	1499-00.900.06	O-Ring	O-ring	Joint torique
	1489-00.900.12	Seil, 22 mtr.	Cord, 22 m	Corde, 22 m
		Nur die aufgeführten Teile sind lieferbar!	Only the mentioned spare parts are available!	Seules les pièces indiquées sont disponibles!

Achtung!! Die mit „ # “ gekennzeichneten Ersatzteile dürfen ausschliesslich von einer Elektrofachkraft nach Vorgabe des Herstellers unter Berücksichtigung der gesetzlichen Vorschriften ersetzt werden.

Attention!! Those with „ # “ of marked spare parts may be replaced exclusively from an electrical specialist to default of the manufacturer with consideration of the laws.

Attention!! A la demande du fabricant et conformément aux instructions légales, les pièces détachées marquées d'un „ # “ doivent être remplacées exclusivement par des techniciens spécialisés.