

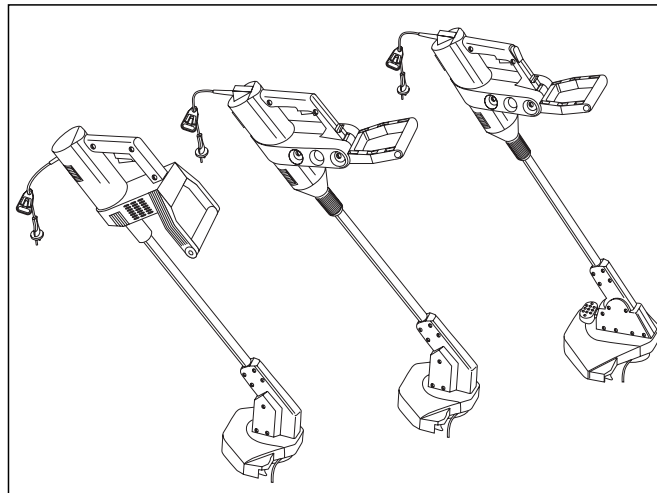

Trimmersense 350 / 350 L / 530 Duo L
String Trimmer 350 / 350 L / 530 Duo L
Coupe-herbes 350 / 350 L / 530 Duo L
Bostrimmer 350 / 350 L / 530 Duo L
Stringtrimmer 350 / 350 L / 530 Duo L
Rifilatore 350 / 350 L / 530 Duo L
Turbotrimmer 350 / 350 L / 530 Duo L
Aparador de relva String Trimmer
350 / 350 L / 530 Duo L



Gebrauchsanweisung
Operating Instructions
Mode d'emploi
Gebruiksaanwijzing
Bruksanvisning
Istruzioni per l'uso
Manual de instrucciones
Instruções de manejo

Beachten Sie die Sicherheitshinweise auf dem Gerät:
 Please adhere to the following safety instructions on the unit:
 Veuillez observer les instructions de sécurité figurant sur l'appareil :
 Houdt u zich aan de veiligheidsvoorschriften op het apparaat:
 Följ bruksanvisningen noga:
 Attenzione ai simboli di sicurezza sull'attrezzo:
 Observen las indicaciones de seguridad en el aparato:
 Por favor siga atentamente as instruções de segurança fornecidas no aparelho:



**Achtung! Vor Inbetriebnahme
 Gebrauchsanweisung lesen!
 Warning! Read instruction handbook!
 Merci de lire attentivement le mode
 d'emploi avant d'utiliser cet appareil !
 Let op! Voor ingebruikname de ge-
 bruiksaanwijzing lezen!**

**OBS! Läs igenom bruksanvisningen noga
 före användning!
 Attenzione! Prima di mettere in funzione
 l'attrezzo, leggere le istruzioni per l'uso!
 ¡Atención! Antes de la puesta en marcha,
 lea el manual de instrucciones.
 Atenção! Leia o Manual de instruções antes
 da utilização!**



**Vor Regen und Nässe schützen!
 Do not use in rain or wet conditions!
 Protégez l'appareil de la pluie et de
 l'humidité !
 Niet aan vocht blootstellen!**

**Använd inte maskinen i regn eller fuktig
 miljö!
 Proteggere l'attrezzo dall'umidità o dalla
 pioggia!
 ¡Proteja el aparato de la lluvia y la humedad!
 Proteja o aparelho da chuva e da humidade!**

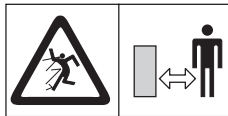

**Dritte aus dem Gefahrenbereich
 fernhalten!
 Keep bystanders away!
 Maintenez tout tiers hors de la zone
 de travail !
 Houdt omstanders uit de buurt!**

**Tillse att inga obehöriga vistas i området!
 Tenere lontano i terzi dalla zona di lavoro!
 ¡Mantener alejados a terceros del área de
 trabajo!
 Mantenha terceiros fora da área de perigo!**

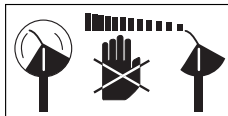

**Werkzeug läuft nach!
 Tool goes behind!
 Attention ! Après avoir lâché l'inter-
 rupteur, le système de coupe con-
 tinue de tourner quelques instants.
 Machine loopt na!**

**Varning! Skärverktyget fortsätter att rotera
 ett tag efter motorn stängts av!
 Attenzione! Appena spento, l'attrezzo gira
 ancora alcuni istanti per inerzia!
 ¡Atención! Funcionamiento por inercia.
 Atenção! Após desligar o interruptor o fio
 de corte ainda continua em movimento
 durante alguns instantes.**



**Augenschutz tragen!
 Wear eye protection!
 Portez des lunettes de protection !
 Draag oogbescherming!**

**Använd skyddsglasögon!
 Indossare gli occhiali di protezione!
 ¡Use gafas de protección!
 Use protecção nos seus olhos!**

Kennzeichnung von Stellteilen (nur Trimmersense TS 530 Duo L, Art.-Nr. 2548)
Identification of controls (String Trimmer TS 530 Duo L, art. no. 2548, only)
Identification des parties réglables seulement Coupe-herbes TS 530 Duo L, réf. 2548)
Aanduiding van diverse functies (alleen Bostrimmer TS 530 Duo L, art.nr. 2548)
Kontrollidentifizierung (endast Stringtrimmer TS 530 Duo L, artikelnr. 2548)
Identificazione dei comandi (solo Rifilatore TS 530 Duo L, art. 2548)
Descripción de controles (sólo Turbotrimmer TS 530 Duo L, Art. Nº 2548)
Identificação de comandos (apenas Aparador de relva String Trimmer TS 530 Duo L, art.nº 2548)

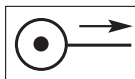

**Fadenverlängerung
 Cord lengthening
 Avance du fil de coupe
 Draadverlenging
 Trådmatning**

**Allungamento del filo di taglio
 Alargamiento del hilo
 Prolongamento do fio**

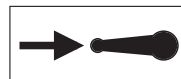

**Verstellung des Zusatzhandgriffes
 Adjusting the additional handle
 Réglage de la poignée supplémentaire
 Verstellen van de extra handgreep
 Extrahandtagets inställning**

**Regolazione dell'impugnatura supplementare
 Reajuste de la empuñadura adicional
 Ajuste do manipulo adicional**

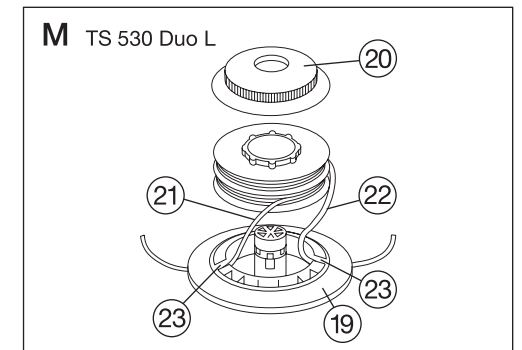
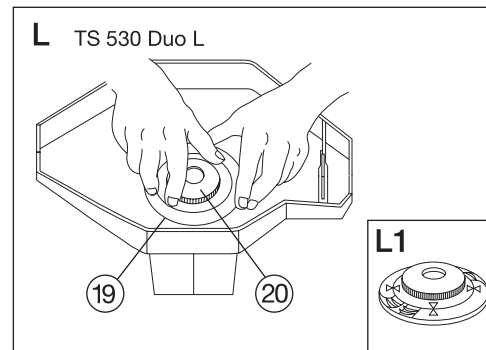
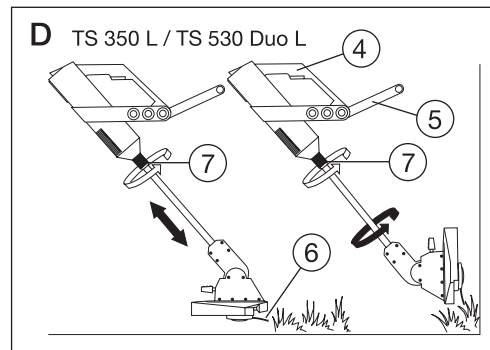
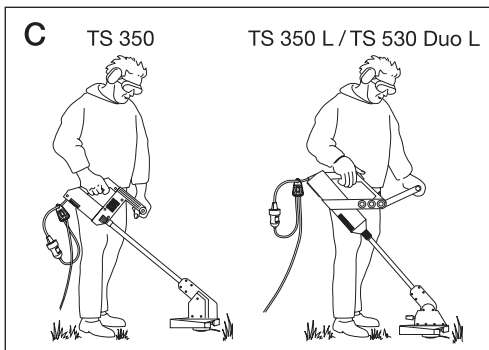
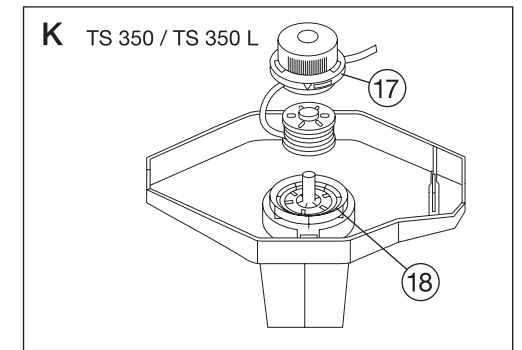
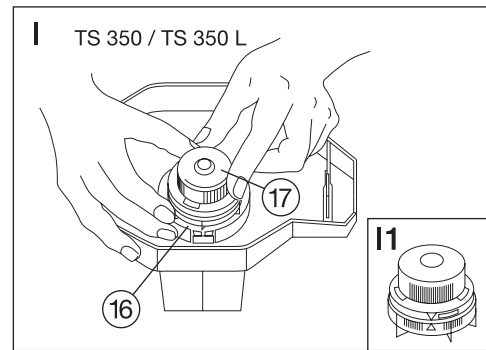
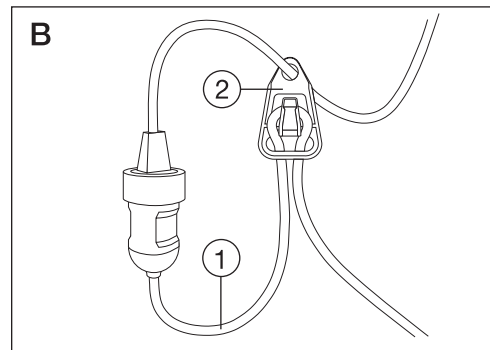
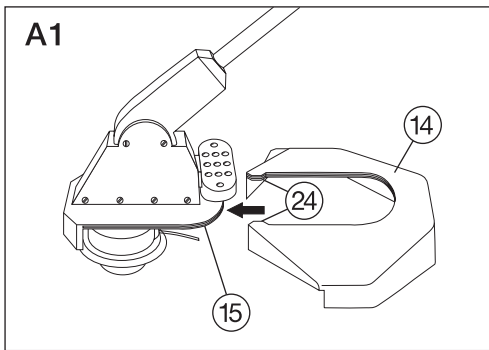
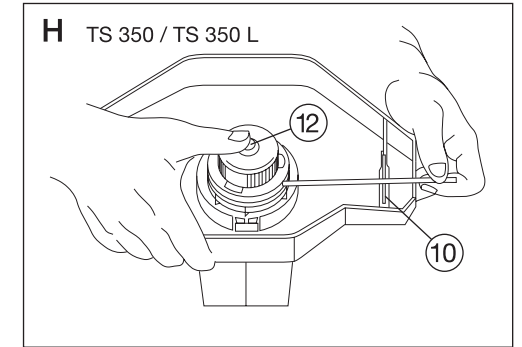
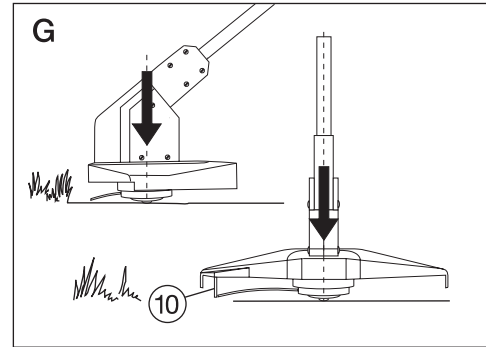
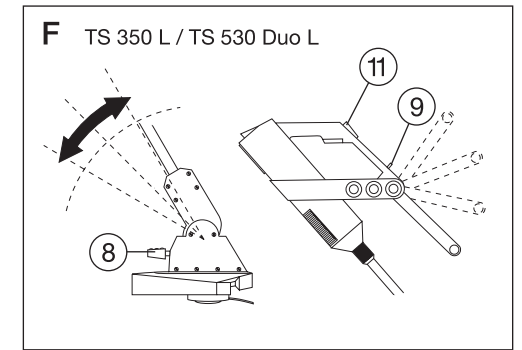
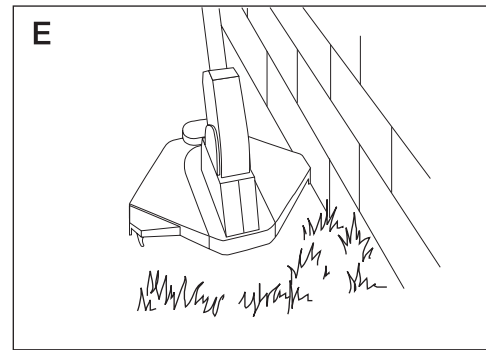
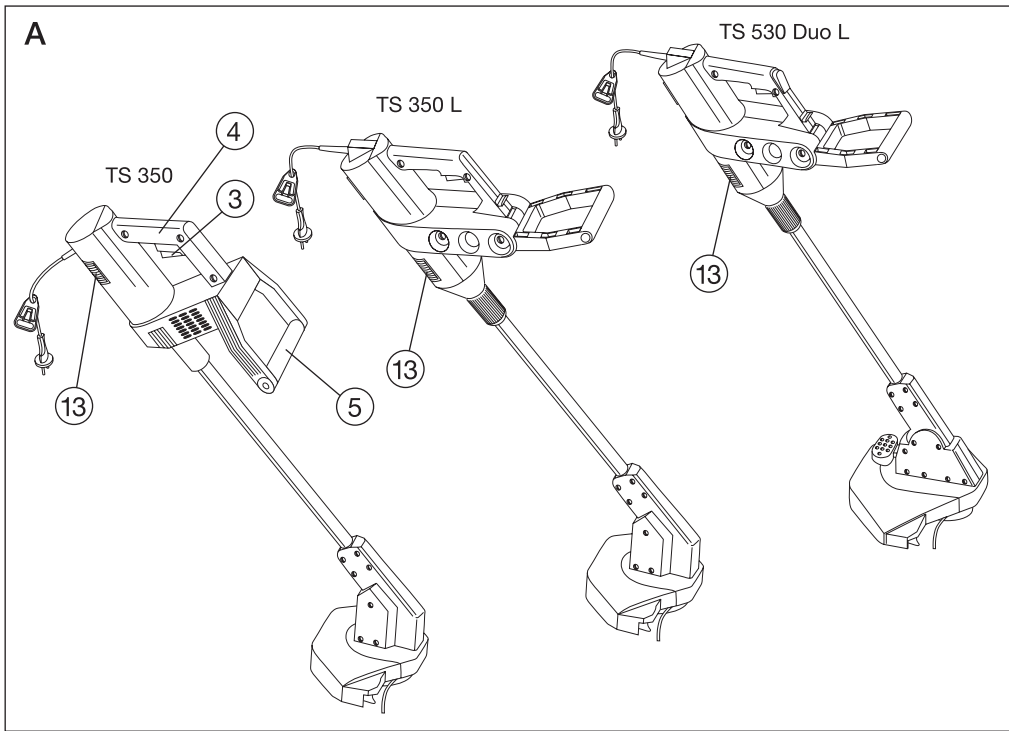

GARDENA String Trimmer TS 350 / TS 350 L / TS 530 Duo L

1. Technical data

		TS 350	TS 350 L	TS 530 Duo L
Motor output	W	350	350	530
Supply voltage	V	230	230	230
Frequency	Hz	50/60	50/60	50/60
String strength	mm	1.6	1.6	1.6
Cutting width	mm	250	250	300
String supply	m	6	6	2 x 5
Weight	kg	approx. 2.8	3.0	3.4
Rpm of string cartridge	rpm	12,000	12,000	12,000
Working area related emission characteristic value $L_{pA}^{1)}$	dB(A)	86	85	91
Noise level $L_{WA}^{2)}$	dB(A)	96	96	96
Vibrations $a_{vhw}^{1)}$	ms ⁻²	< 2.5	3.5	< 2.5

Measuring method ¹⁾ according to EN 786 ²⁾ according to 84/538/EC

2. Information regarding the operating instructions

Please read and follow these operating instructions carefully. Familiarise yourself with the unit's features, the controls, its proper use and the safety instructions included.

 **For safety reasons children under the age of 16 or people who are not familiar with these operating instructions should not use this String Trimmer.**

Please keep these operating instructions in a safe place.

3. Product use

The GARDENA String Trimmers TS 350 / TS 350 L / TS 530 Duo L are designed for trimming/cutting lawn areas in private house and hobby gardens.

These trimmers are for private use only and are not designed

for use in public facilities, parks, sporting grounds, on roads, in agriculture or forestry.

It is essential to observe the manufacturer's operating instructions to ensure the unit's proper functioning. These instructions

also contain advice for service, maintenance and repair.

 **Attention! For safety reasons the unit must not be used for hedge trimming or for chopping up for composting.**

4. Assembly (ill. A 1)

Before beginning work, insert the enclosed safety cover (14) into the groove of the cutting head support (15) to the end stop and push firmly onto both locks (24). Listen for audible snap-in.

Note:
Check whether the cover is properly seated by pulling in the opposite direction. If properly mounted, the safety cover is undetachable from the cutting head support.

5. Using the product (ill. A-H)

5.1 How to connect the String Trimmer – cable lock / extension cable (ill. A/B)
Loop the extension cable (1) and insert it into the cable lock (2). This prevents unintentional disconnection of the electrical plug. Then plug into the mains cable. To switch on, depress the push-button (3) on the handle (4). The String Trimmer will switch off as soon as the push-button is released.

 **The safety devices installed by the manufacturer must not be removed or by-passed, e.g. by binding the on/off switch to the handle. This will prevent the trimmer switching off automatically, and may cause serious injury.**

Attention! The trimming string will take a while to stop running after the unit is switched off.

5.2 Working position (ill. C)
Ensure that you have a secure foothold when working. Hold your String Trimmer with one hand on the handle (4), with the other on the guide handle (5).

5.3 Trimming along lawn edges and in awkward places (ill. D) (String Trimmer TS 350 L / TS 530 Duo L)
Guide your String Trimmer using the handle (4) and the guide handle (5).
For vertical cutting, e. g. for trimming lawn edges, turn the cutting unit as described under 5.6 below.

5.4 Trimming along the base of walls, fences and around trees (ill. E)
Guide your String Trimmer with the left side of the cover at a short distance from hard objects and surfaces.

5.5 Removing dirt from joints between pavers (ill. C/D)
Hold the String Trimmer in such a way that the cutting string (6) runs slightly inclined just above the pavers.

5.6 Turning and swivelling the cutting tool, telescopic adjustment (ill. D/F)

Turning
(for trimming lawn edges) (String Trimmer TS 350 L / TS 530 Duo L)
Loosen the tightening nut (7) on the motor casing. The connecting tube with the cutting tool can then be turned by up to 180°. Secure the cutting tool in the desired position by tightening the nut.

Telescopic adjustment
(to suit the operators height) (String Trimmer TS 350 L / TS 530 Duo L)
Loosen the tightening nut (7) on the motor casing. The length of the connecting tube with the cutting tool can then be adjusted by up to 100 mm.

Swivelling
(for mowing on slopes, under bushes and garden furniture) (String Trimmer TS 530 Duo L)
By depressing the switch (8), you can swivel or incline the handle into two other angles of 15° allowing three different working positions (ill. F).

5.7 Adjusting the guide handle (ill. F) (String Trimmer TS 350 L / TS 530 Duo L)
By releasing the adjustment element (9) you can adjust the guide handle to the desired working position.
Adjust the position of the guide handle to suit your body height so that the String Trimmer can be guided just above the ground with an ideal weight balance.

5.8 Automatic string lengthening procedure with the motor running (ill. G) (String Trimmer TS 350 / TS 350 L)
A clean cut will only be achieved with the maximum cord length.

Tap your trimmer **sharply** on the ground. **Avoid sustained depression.** Ensure that the cutting head is parallel to ground. The cord will automatically lengthen. Listen for audible switching action. If the string is too long, it will be automatically adjusted to the correct length by the string limiter blade (10).

5.9 Automatic string lengthening procedure with the motor running (String Trimmer TS 530 Duo L)
A clean cut will only be achieved with the maximum cord length.
Briefly press and release the switch (11) to start/stop the motor. This causes automatic lengthening of the string. Listen for audible switching action. If the string is too long it will be automatically adjusted to the correct length by the string limiter blade (10).

5.10 Manual string lengthening (ill. H)
1. **Disconnect the mains plug!**
2. Depress the release (12) and manually pull out string or strings until it stops.
If necessary, repeat this procedure until the string just projects over the edge of the cover.

While the String Trimmer is being operated, the string length is adjusted automatically as described under "Automatic string lengthening".

 **Be careful with the cutting blade/string limiter (10) whilst lengthening the string by hand. Risk of injury!**

6. Maintenance, service, storage

The GARDENA String Trimmers require minimal maintenance.

Make sure that the cooling air inlets (13) never become obstructed by dirt.

Remove grass clippings and dirt with a dry cloth or brush. Remove grass clippings and dirt from the safety cover (14) after every use.

Repairs may only be carried out by GARDENA Service Centres or dealers authorised by GARDENA.

 **Attention! Always disconnect the mains plug before working on the String Trimmer (checking, cleaning, maintenance). Risk of injury!**

To avoid injury to persons and product damage: Never clean the String Trimmer with running water or with a water jet, in particular a high pressure water jet.

Store the String Trimmer in a dry place where it is protected from frost.

We recommend hanging storage to avoid unnecessary stress on the cutting head. The String Trimmer should be stored out of the reach of children.

Follow the manufacturer's instructions when replacing the string cartridge.

6.1 How to replace the string
Please use only the original GARDENA String Cartridges.

Art. No. 5371
for String Trimmer TS 350 / TS 350 L

Art. No. 5372
for String Trimmer TS 530 Duo L

You can order these string cartridges from your GARDENA dealer or directly from the GARDENA customer service.

Never use metallic cutting cartridges or spare parts and accessories which have not been defined by the manufacturer!

String Trimmer TS 350 / TS 350 L (ill. I/K)

Disassembly (ill. I)

1. **Disconnect the mains plug!**
2. Keep the reel holder (16) in a fixed position. Unlock the cover (17) by turning it to the left. Remove the reel.

Assembly (ill. I/K)

1. Make sure the bayonet lock (18) of the reel holder (16) is free of dirt.
2. Introduce the string in the filament guide of the cover (17), then insert the reel.
3. Keep the reel holder (16) in a fixed position.
4. Insert the cover with the reel (17), press down and turn to the right until the end stop. Ensure that the marks on the reel holder (16) and on the cover (17) perfectly match (ill. I1).

Ensure correct working position before switching on the String Trimmer.

String Trimmer TS 530 Duo L (ill. L/M)

Disassembly (ill. L)

1. **Disconnect the mains plug!**
2. Keep the reel holder (19) in a fixed position. Unlock the cover (20) by turning it to the left. Remove the reel.

Assembly (ill. L/M)

1. Introduce first the lower string (21), then the upper string (22) in the string guides (23) of the reel holder (19), then insert the reel completely in the reel holder (19).
2. Keep the reel holder (19) in a fixed position, insert the cover (20), press down and secure

by turning to the right **until it stops.**

3. Ensure that the arrows on the reel holder (19) and on the cover (20) match perfectly (ill. L1).

Ensure correct working position before switching on the String Trimmer.

If you have any problem with your String Trimmer, please contact our Customer Service or return the defective unit together with a short description of the problem and, if covered under guarantee, with the warranty card duly completed and signed, directly to one of the GARDENA Service Centres listed on the back of this leaflet.

We expressly point out that, in accordance with the product liability law, we are not liable for any damage caused by our units if it is due to improper repair or if parts exchanged are not original GARDENA parts or parts approved by us, and, if the repairs were not carried out by a GARDENA Service Centre or an authorised specialist. The same applies to spare parts and accessories.

7. Advice for proper use, safety instructions

 Inspect the unit before each use

Do not use the String Trimmer, if safety devices (push button, safety cover) and/or the string cartridge are damaged or worn. Never by-pass safety devices.

Inspect the area to be cut before and during work. Remove any foreign objects such as stones.

If, in spite of care, you come into contact with an obstruction whilst cutting, turn off the trimmer and remove it.

Check the unit for possible damage and have it repaired, if necessary.

 Use/Responsibility

This String Trimmer can cause serious injuries!

Use the unit only for purposes specified in these operating instructions.

You are responsible for the safety in the working area.

Make sure that there are no other people (especially children) or animals within or near the working area.

Never use the String Trimmer if safety devices are damaged or defective!

Disconnect the mains plug. Check the String Trimmer, especially the string cartridge regularly and replace it, if necessary.

Wear an eye shield or goggles!

Wear sturdy shoes and long trousers to protect your legs. Keep fingers and feet away from the cutting string – above all when starting work.

Ensure that you have secure foothold whilst working. The electrical cable should always be kept away from the cutting area.

Attention! Take extra care when walking backwards. You may stumble.

Only work when visibility is good.

 Interrupting work

Never leave the String Trimmer unattended in the working place. If you stop work, store the trimmer in a safe place. Disconnect the mains plug!

Should you stop work in order to get to another working place, always switch off the Trimmer, wait until the tool stops and disconnect the mains plug!

 Work place safety

Make yourself familiar with the surroundings and look out for dangers which you may not detect due to machinery noise.

Never use the unit when it rains or in damp/wet areas.

Do not operate the String Trimmer in or near swimming pools and garden ponds.

 Electrical safety

Check the power cable regularly for damage and signs of wear and tear.

The String Trimmer must only be operated with an undamaged electric cable. If the mains- or extension cable is damaged, disconnect the mains plug immediately.

The socket of an extension cable should be waterproof.

Only use permitted extension cables. Ask your electrician.

For portable units which are used outdoors, we recommend to use a fault circuit breaker.

In Switzerland use of a fault circuit breaker is obligatory.

Certificate of Conformity

The undersigned

GARDENA Kress + Kastner GmbH · Hans-Lorensen-Str. 40 · D-89079 Ulm

hereby certifies that the String Trimmers

Design	Electric motor	Electric motor
Manufacturer	GARDENA	GARDENA
Type	TS 350 / TS 350 L	TS 530 Duo L
Motor	Manufacturer Type Rotational speed	GARDENA universal motor 12,000 r.p.m.
		GARDENA universal motor 12,000 r.p.m.

are in accordance with the 84/538/EEC guideline.

Guaranteed max. noise level	96 dB (A)	96 dB (A)
Cutting width	250 mm	300 mm
Type if cutting device	nylon string	nylon string

Ulm, 30.06.1997



ppa. J. Katzer
Technical Dept. Manager

EU Certificate of Conformity

The undersigned

GARDENA Kress + Kastner GmbH · Hans-Lorensen-Str. 40 · D-89079 Ulm

hereby certifies that, when leaving our factory, the units indicated below are in accordance with the harmonised EU guidelines, EU standards of safety and product specific standards.

This certificate becomes void if the units are modified without our approval.

Description of the units:

String Trimmer

Types:

TS 350 / TS 350 L / TS 530 Duo L

Art. No.:

2545 / 2546 / 2548

EU directives:

Machinery Directive 89/392/EC
mod. 91/368/EC
Electromagnetic Compatibility
89/336/EC
Low Voltage Directive 73/23/EC
Directive 93/68/EC

Harmonised

European standard:

EN 292-1
EN 292-2
EN 786
EN 60335-1

National standards:

DIN VDE 0730 part 1
DIN VDE 0730 part 2 ZP

Year of CE marking:

1996 (TS 350 L / TS 530 Duo L)
1997 (TS 350)

Ulm, 30.06.1997

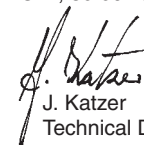
J. Katzer
Technical Dept. Manager

D

Garantie

GARDENA gewährt für dieses Produkt 1 Jahr Garantie (ab Kaufdatum). Diese Garantieleistung bezieht sich auf alle wesentlichen Mängel des Gerätes, die nachweislich auf Material- oder Fabrikationsfehler zurückzuführen sind. Sie erfolgt durch die Ersatzlieferung eines einwandfreien Gerätes oder durch die kostenlose Reparatur des eingesandten Gerätes nach unserer Wahl, wenn folgende Voraussetzungen gewährleistet sind:

- Das Gerät wurde sachgemäß und laut den Empfehlungen in der Gebrauchsanweisung behandelt. Es wurde weder vom Käufer noch von einem Dritten versucht, das Gerät zu reparieren.
- Das Gerät wurde ausreichend frankiert direkt an eine der GARDENA Servicestellen gesandt, unter Beifügung der vollständig ausgefüllten Garantiekarte bzw. des Rechnungsbeleges.

Diese Hersteller-Garantie berührt die gegenüber dem Händler/Verkäufer bestehenden Gewährleistungsansprüche nicht.

Verschleißteile (z. B. Faden, Schneidkopf-Deckel) sind von der Garantie ausgeschlossen.

GB

Guarantee

GARDENA guarantees this product for 1 year (from date of purchase). This guarantee covers all serious defects of the unit that can be proved to be material or manufacturing faults. Under guarantee we will either replace the unit or repair it free of charge if following conditions apply:

- The unit must have been handled properly and in keep-

ing with the requirements of the operating instructions. In addition, no attempt at repair by the customer or a non-authorised third party is permitted.

- The unit is returned directly postage paid to a GARDENA Service Centre together with the warranty card duly completed and signed.

This manufacturer's guarantee does not affect the user's existing warranty claims against the dealer/seller.

Parts subject to wear (e.g. string, cutting head cover) are excluded from this guarantee.

F

Garantie

Pour mieux vous servir, GARDENA accorde une garantie contractuelle de 1 an à compter du jour de l'achat. Elle est assurée sur décision de GARDENA par le remplacement gratuit des pièces défectueuses ou de l'appareil.

En tout état de cause s'applique la garantie légale couvrant toutes les conséquences des défauts ou vices cachés. (article 1641 et suivants du Code Civil).

Pour que ces garanties soient valables, les conditions suivantes doivent être remplies :

- L'appareil a été manipulé de manière adéquate, suivant les instructions du mode d'emploi.
- Il n'y a eu aucun essai de réparation, ni par le client, ni par un tiers.
- L'appareil et la carte de garantie dûment remplies ont été retournés en port payé au Service Après-Vente de GARDENA France.

Une intervention sous garantie ne prolonge pas la durée initiale de la garantie contractuelle.

Toutes les revendications dépassant le contenu de ce texte ne sont pas couvertes par la garantie, quel que soit le motif de droit.

Pendant la période de garantie, le Service Après-Vente effectuera, à titre payant, les réparations nécessaires par suite de manipulations erronées.

La garantie ne s'étend pas aux pièces d'usure normale (ex : fil de coupe, couvercle de la tête de coupe).

NL

Garantie

GARDENA geeft op dit product 1 jaar garantie (vanaf de aankoopdatum). Deze garantie heeft betrekking op alle wezenlijke defecten aan het toestel, die aanwijsbaar op materiaal- of fabriecagefouten berusten. Garantie vindt plaats door de levering van een vervangend apparaat of door de gratis reparatie van het ingestuurde apparaat, naar onze keuze, indien aan de volgende voorwaarden is voldaan:

- Het apparaat werd vakkundig en volgens de adviezen in de gebruiksaanwijzing behandeld. Noch de koper, noch een derde persoon heeft getracht het apparaat te repareren.
- Het apparaat werd voldoende gefrankeerd aan de GARDENA technische dienst gestuurd, met toevoeging van een volledig ingevulde garantietaal resp. kopie van de rekening.

Deze garantie van de producent heeft geen betrekking op de ten aanzien van de handelaar/verkoper bestaande aansprakelijkheid.

Slijtagegevoelige onderdelen (bijv. draden, snijkopdeksel) vallen niet onder de garantie.

Garantiekarte
Warranty Card
Carte de garantie
Garantiekkaart
Garantikort
Certificato di garanzia
Tarjeta de garantía
Cartão de garantia

GARDENA Trimmersense	TS 350		Art.-Nr. 2545
GARDENA String Trimmer			
Coupe-herbes GARDENA	TS 350 L		Art.-Nr. 2546
GARDENA bostrimmer			
GARDENA Stringtrimmer	TS 530 Duo L		Art.-Nr. 2548
GARDENA Riffilatore			
GARDENA Turbostrimmer			
GARDENA Aparador de relva String Trimmer			

Wurde gekauft am:
Was purchased on:
Acheté le (date et lieu d'achat) :
Werd gekocht op:
Försäljningsdatum:
Data di acquisto:
Se vendió el:
Comprado em:

Händlerstempel:
Dealer's stamp / Receipt:
Cachet du revendeur :
Stempel van de handelaar:
Återförsäljarens stämpel:
Timbro del rivenditore:
Sello del comerciante:
Carimbo do vendedor:

Beanstandung:
Reasons for complaint:
Défaut constaté :
Klacht:
Reklamation:
Reclamo:
Reclamación:
Motivo de reclamação:



Deutschland

GARDENA
Kress + Kastner GmbH
GARDENA Service
Hans-Lorenser-Straße 40
D-89079 Ulm
Produktfragen: (07 31) 490-123
Reparaturen: (07 31) 490-290

Argentina

Unitán s.a.i.c.a.
Paseo Colón 221 – P. 10°
1399 Buenos Aires

Australia

NYLEX Corporation Ltd.
25-29 Nepean Highway
P.O. Box 68
Mentone, Victoria 3194

Austria

GARDENA Österreich
Gesellschaft m.b.H.
Stettnerweg 11-15
2100 Korneuburg

Belgium

MARKT (Belgium) NV/SA
Sterrebeekstraat 163
1930 Zaventem

Canada

Continental Industries
100, Summerlea Road
Brampton, Ontario
Canada L6T 4X3

Chile

Comercial Maquinox
Nueva Panamericana Sur,
N° 1050
San Bernardo
Santiago de Chile

Cyprus

FARMOKIPIKI LTD
P.O. Box 7098
74, Digeni Akrita Ave.
1641 Nicosia

Czech Republic

GARDENA spol. s.r.o.
Brněnská 634
66442 Brno-Modřice

Denmark

GARDENA Danmark A/S
Bejlerholm 10
9400 Nørresundby

Finland

Habitec Oy
Martinkyläntie 52
01720 Vantaa

France

GARDENA France
Service Après-Vente
BP 50080
95948 ROISSY CDG Cedex

Great Britain

GARDENA UK Ltd.
27-28 Brenkley Way
Blezard Business Park
Seaton Burn
Newcastle upon Tyne
NE13 6DS

Greece

Agrokip
G. Psomadopoulos & Co.
20, Lykourgou str.
Kallithea
Athens

Hungary

GARDENA Magyarország Kft.
Késmárk utca 22
1158 Budapest

Iceland

Heimilistaeki hf
Saetun 8
P.O. Box 5340
125 Reykjavik

Italy

GARDENA Italia S.r.l.
Via Donizetti 22
20020 Lainate (Mi)

Japan

KAKUDAI Mfg. Co. Ltd.
1-4-4, Itachibori Nishi-ku
Osaka 550

Luxembourg

Magasins Jules Neuberg
Grand Rue 30
Case Postale No. 12
Luxembourg 2010

Netherlands

MARKT (Holland) BV
Postbus 219
1380 AE Weesp

New Zealand

NYLEX
New Zealand Limited
Head Office
22, Ormiston Road
Private Bag
South Auckland Mail Centre
Auckland

Norway

GARDENA Norge A/S
Postboks 214
2013 Skjetten

Poland

GARDENA Polska Sp. z o.o.
Orzeszyn 35 a
k/Piaseczna
05-532 Baniocza

Portugal

MARKT (Portugal), Lda.
Recta da Granja do Marquês
Algueirão
2725 Mem Martins

Russia / Россия

АО АМИДА
ул. Мосфильмовская 66
117330 Москва

Singapore

Variware
Holland Road Shopping Centre
227-A 1st Fl., Unit 29
Holland Avenue
Singapore 1027

Slovenia

Silk d.o.o. Trgovina
Brodišče 15
1236 Trzin

South Africa

GARDENA
South Africa (Pty.) Ltd.
P.O. Box 11534
Vorna Valley 1686

Spain

ANMI Andreu y Miriam S.A.
Calle Pere IV, 111
08018 Barcelona

Sweden

GARDENA Svenska AB
Box 9003
20039 Malmö

Switzerland

GARDENA Kress + Kastner AG
Bitziberg 1
8184 Bachenbülach

Turkey

Bahçe Tarım ve Sulama
Araçları Ticaret A.Ş.
Soğanlık Yolu, Yalınız
Selvi Sok. No: 21
81440 Kartal-İstanbul

USA

GARDENA
3085 Shawnee Drive
Winchester, VA 22604

2546-20.960.05/0992
GARDENA Kress + Kastner GmbH
Postfach 27 47, D-89070 Ulm
<http://www.gardena.de>