

# **OWNER'S MANUAL**

## **MODEL NO. LT14A (JNA14H36A)**

### **13.5 HP 36 Inch Lawn Tractor**

- **Assembly**
- **Operation**
  - **Customer Responsibilities**
  - **Service and Adjustments**
  - **Storage**
    - **Troubleshooting**
    - **Repair Parts**

---

# **Jonsered**

# SAFETY RULES



## SAFE OPERATION PRACTICES FOR RIDE-ON MOWERS



**IMPORTANT:** THIS CUTTING MACHINE IS CAPABLE OF AMPUTATING HANDS AND FEET AND THROWING OBJECTS. FAILURE TO OBSERVE THE FOLLOWING SAFETY INSTRUCTIONS COULD RESULT IN SERIOUS INJURY OR DEATH.

### I. GENERAL OPERATION

- Read, understand, and follow all instructions in the manual and on the machine before starting.
- Only allow responsible adults, who are familiar with the instructions, to operate the machine.
- Clear the area of objects such as rocks, toys, wire, etc., which could be picked up and thrown by the blade.
- Be sure the area is clear of other people before mowing. Stop machine if anyone enters the area.
- Never carry passengers.
- Do not mow in reverse unless absolutely necessary. Always look down and behind before and while backing.
- Be aware of the mower discharge direction and do not point it at anyone. Do not operate the mower without either the entire grass catcher or the guard in place.
- Slow down before turning.
- Never leave a running machine unattended. Always turn off blades, set parking brake, stop engine, and remove keys before dismounting.
- Turn off blades when not mowing.
- Stop engine before removing grass catcher or unclogging chute.
- Mow only in daylight or good artificial light.
- Do not operate the machine while under the influence of alcohol or drugs.
- Watch for traffic when operating near or crossing roadways.
- Use extra care when loading or unloading the machine into a trailer or truck.
- Data indicates that operators, age 60 years and above, are involved in a large percentage of riding mower-related injuries. These operators should evaluate their ability to operate the riding mower safely enough to protect themselves and others from serious injury.
- Keep machine free of grass, leaves or other debris build-up which can touch hot exhaust / engine parts and burn. Do not allow the mower deck to plow leaves or other debris which can cause build-up to occur. Clean any oil or fuel spillage before operating or storing the machine. Allow machine to cool before storage.

### II. SLOPE OPERATION

Slopes are a major factor related to loss-of-control and tipover accidents, which can result in severe injury or death. All slopes require extra caution. If you cannot back up the slope or if you feel uneasy on it, do not mow it.

#### DO:

- Mow up and down slopes, not across.
- Remove obstacles such as rocks, tree limbs, etc.
- Watch for holes, ruts, or bumps. Uneven terrain could overturn the machine. *Tall grass can hide obstacles.*
- Use slow speed. Choose a low gear so that you will not have to stop or shift while on the slope.
- Follow the manufacturer's recommendations for wheel weights or counterweights to improve stability.
- Use extra care with grass catchers or other attachments. These can change the stability of the machine.
- Keep all movement on the slopes *slow* and *gradual*. Do not make sudden changes in speed or direction.

- Avoid starting or stopping on a slope. If tires lose traction, disengage the blades and proceed slowly *straight* down the slope.

#### DO NOT:

- *Do not* turn on slopes unless necessary, and then, turn slowly and gradually downhill, if possible.
- *Do not* mow near drop-offs, ditches, or embankments. The mower could suddenly turn over if a wheel is over the edge of a cliff or ditch, or if an edge caves in.
- *Do not* mow on wet grass. Reduced traction could cause sliding.
- *Do not* try to stabilize the machine by putting your foot on the ground.
- *Do not* use grass catcher on steep slopes.

### III. CHILDREN

Tragic accidents can occur if the operator is not alert to the presence of children. Children are often attracted to the machine and the mowing activity. *Never* assume that children will remain where you last saw them.

- Keep children out of the mowing area and under the watchful care of another responsible adult.
- Be alert and turn machine off if children enter the area.
- Before and when backing, look behind and *down* for small children.
- Never carry children. They may fall off and be seriously injured or interfere with safe machine operation.
- Never allow children to operate the machine.
- Use extra care when approaching blind corners, shrubs, trees, or other objects that may obscure vision.

### IV. SERVICE

- Use extra care in handling gasoline and other fuels. They are flammable and vapors are explosive.
  - Use only an approved container.
  - Never remove gas cap or add fuel with the engine running. Allow engine to cool before refueling. Do not smoke.
  - Never refuel the machine indoors.
  - Never store the machine or fuel container inside where there is an open flame, such as a water heater.
- Never run a machine inside a closed area.
- Keep nuts and bolts, especially blade attachment bolts, tight and keep equipment in good condition.
- Never tamper with safety devices. Check their proper operation regularly.
- Keep machine free of grass, leaves, or other debris build-up. Clean oil or fuel spillage. Allow machine to cool before storing.
- Stop and inspect the equipment if you strike an object. Repair, if necessary, before restarting.
- Never make adjustments or repairs with the engine running.
- Grass catcher components are subject to wear, damage, and deterioration, which could expose moving parts or allow objects to be thrown. Frequently check components and replace with manufacturer's recommended parts, when necessary.
- Mower blades are sharp and can cut. Wrap the blade(s) or wear gloves, and use extra caution when servicing them.
- Check brake operation frequently. Adjust and service as required.

# SAFETY RULES



## Safe Operation Practices for Ride-On Mowers



- Be sure the area is clear of other people before mowing. Stop machine if anyone enters the area.
- Never carry passengers or children even with the blades off.
- Do not mow in reverse unless absolutely necessary. Always look down and behind before and while backing.
- Never carry children. They may fall off and be seriously injured or interfere with safe machine operation.
- Keep children out of the mowing area and under the watchful care of another responsible adult.
- Be alert and turn machine off if children enter the area.
- Before and when backing, look behind and down for small children.
- Mow up and down slopes (15° Max), not across.
- Remove obstacles such as rocks, tree limbs, etc.
- Watch for holes, ruts, or bumps. Uneven terrain could overturn the machine. Tall grass can hide obstacles.
- Use slow speed. Choose a low gear so that you will not have to stop or shift while on the slope.
- Avoid starting or stopping on a slope. If tires lose traction, disengage the blades and proceed slowly straight down the slope.
- If machine stops while going uphill, disengage blades, shift into reverse and back down slowly.
- Do not turn on slopes unless necessary, and then, turn slowly and gradually downhill, if possible.



Look for this symbol to point out important safety precautions. It means **CAUTION!!! BECOME ALERT!!! YOUR SAFETY IS INVOLVED.**



**CAUTION:** In order to prevent accidental starting when setting up, transporting, adjusting or making repairs, always disconnect spark plug wire and place wire where it cannot contact spark plug.



**CAUTION:** Do not coast down a hill in neutral, you may lose control of the tractor.



**CAUTION:** Tow only the attachments that are recommended by and comply with specifications of the manufacturer of your tractor. Use common sense when towing. Operate only at the lowest possible speed when on a slope. Too heavy of a load, while on a slope, is dangerous. Tires can lose traction with the ground and cause you to lose control of your tractor.



### WARNING



Engine exhaust, some of its constituents, and certain vehicle components contain or emit chemicals known to the State of California to cause cancer and birth defects or other reproductive harm.



### WARNING



Battery posts, terminals and related accessories contain lead and lead compounds, chemicals known to the State of California to cause cancer and birth defects or other reproductive harm. Wash hands after handling.

## PRODUCT SPECIFICATIONS

GASOLINE CAPACITY AND TYPE:	1.25 GALLONS UNLEADED REGULAR
OIL TYPE (API-SF-SJ):	SAE 30 (above 32°F) SAE 5W-30 (below 32°F)
OIL CAPACITY:	3.0 PINTS
SPARK PLUG: (GAP: .030")	CHAMPION RJ19LM
GROUND SPEED (MPH):	FORWARD: 5.2 REVERSE: 2.7
TIRE PRESSURE:	FRONT: 14 PSI REAR: 12 PSI
CHARGING SYSTEM:	3 AMPS BATTERY 5 AMPS HEADLIGHTS
BATTERY:	AMP/HR: 28 MIN. CCA: 230 CASE SIZE: U1R
BLADE BOLT TORQUE:	27-35 FT. LBS.

**CONGRATULATIONS** on your purchase of a new tractor. It has been designed, engineered and manufactured to give you the best possible dependability and performance.

Should you experience any problem you cannot easily remedy, please contact your nearest authorized service center/department. We have competent, well-trained technicians and the proper tools to service or repair this tractor.

Please read and retain this manual. The instructions will enable you to assemble and maintain your tractor properly. Always observe the "SAFETY RULES".

## CUSTOMER RESPONSIBILITIES

- Read and observe the safety rules.
- Follow a regular schedule in maintaining, caring for and using your tractor.
- Follow the instructions under "Customer Responsibilities" and "Storage" sections of this owner's manual.

**WARNING:** This tractor is equipped with an internal combustion engine and should not be used on or near any unimproved forest-covered, brush-covered or grass-covered land unless the engine's exhaust system is equipped with a spark arrester meeting applicable local or state laws (if any). If a spark arrester is used, it should be maintained in effective working order by the operator.

A spark arrester for the muffler is available through your nearest authorized service center/department (See REPAIR PARTS section of this manual).

---

## TABLE OF CONTENTS

---

SAFETY RULES .....	2-3
PRODUCT SPECIFICATIONS .....	4
CUSTOMER RESPONSIBILITIES .....	4, 15-18
ASSEMBLY .....	6-8
OPERATION .....	9-14
MAINTENANCE SCHEDULE .....	15

SERVICE AND ADJUSTMENTS .....	19-23
STORAGE .....	24
TROUBLESHOOTING .....	25-26
REPAIR PARTS - TRACTOR .....	28-42

# UNASSEMBLED PARTS

## Steering Wheel

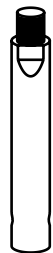
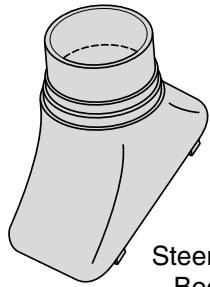
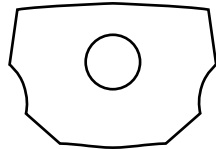
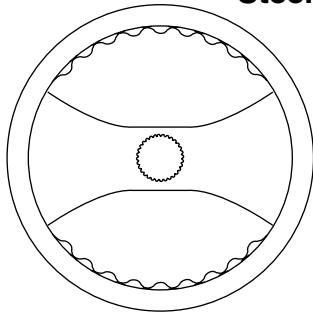

Steering  
Extension  
Shaft

Steering  
Boot

(1) Large Flat  
Washer

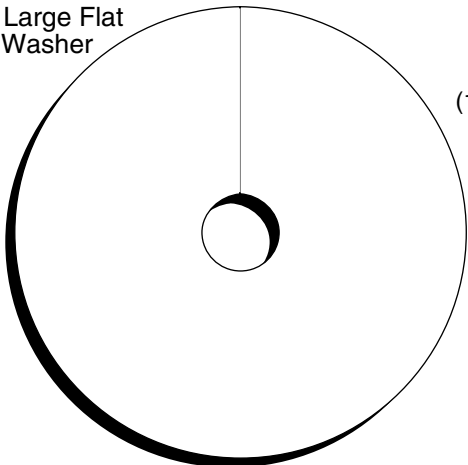

(1) Locknut 1/2-20

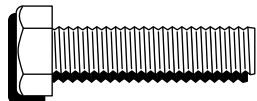
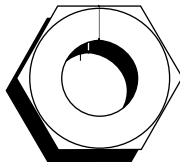

(1) Hex Bolt 1/4-28 x 1-1/4

(1) Locknut 1/4-28



## Seat

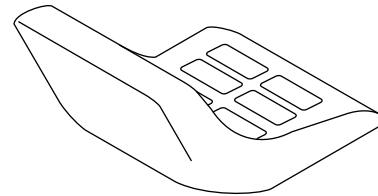

(1) Washer 17/32 x 1-3/16 x 12 Gauge



(1) Lock Washer 1/2



(1) Bolt



(1) Oil Drain Tube  
For Future Use

## Key

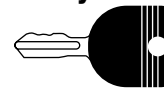

(2) Keys

## Slope Sheet

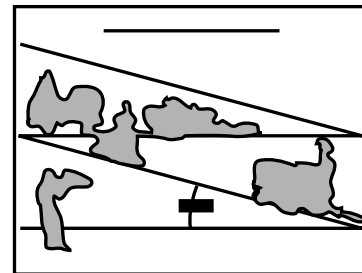

# ASSEMBLY

Your new tractor has been assembled at the factory with exception of those parts left unassembled for shipping purposes. To ensure safe and proper operation of your tractor all parts and hardware you assemble must be tightened securely. Use the correct tools as necessary to insure proper tightness.

## TOOLS REQUIRED FOR ASSEMBLY

A socket wrench set will make assembly easier. Standard wrench sizes are listed.

- (1) 3/4" wrench                      Pliers
- (2) 7/16" wrenches                Tire pressure gauge
- Utility knife

When right or left hand is mentioned in this manual, it means when you are in the operating position (seated behind the steering wheel).

## TO REMOVE TRACTOR FROM CARTON

### UNPACK CARTON

- Remove all accessible loose parts and parts cartons from carton.
- Cut, from top to bottom, along lines on all four corners of carton, and lay panels flat.
- Check for any additional loose parts or cartons and remove.

## BEFORE REMOVING TRACTOR FROM SKID

### ATTACH STEERING WHEEL (See Fig. 1)

#### ASSEMBLE EXTENSION SHAFT AND BOOT

- Slide extension shaft onto lower steering shaft. Align mounting holes in extension and lower shafts and install 1/4 hex bolt and locknut. Tighten securely.

**IMPORTANT:** TIGHTEN BOLT AND NUT SECURELY TO 10-12 FT. LBS TORQUE.

- Place tabs of steering boot over tab slots in dash and push down to secure.

#### INSTALL STEERING WHEEL

- Position front wheels of the tractor so they are pointing straight forward.
- Remove steering wheel adapter from steering wheel and slide adapter onto steering shaft extension.
- Position steering wheel so cross bars are horizontal (left to right) and slide inside boot and onto adapter.
- Assemble large flat washer, 1/2 hex nut and tighten securely.
- Snap steering wheel insert into center of steering wheel.
- Remove protective materials from tractor hood and grill.

**IMPORTANT:** CHECK FOR AND REMOVE ANY STAPLES IN SKID THAT MAY PUNCTURE TIRES WHERE TRACTOR IS TO ROLL OFF SKID.

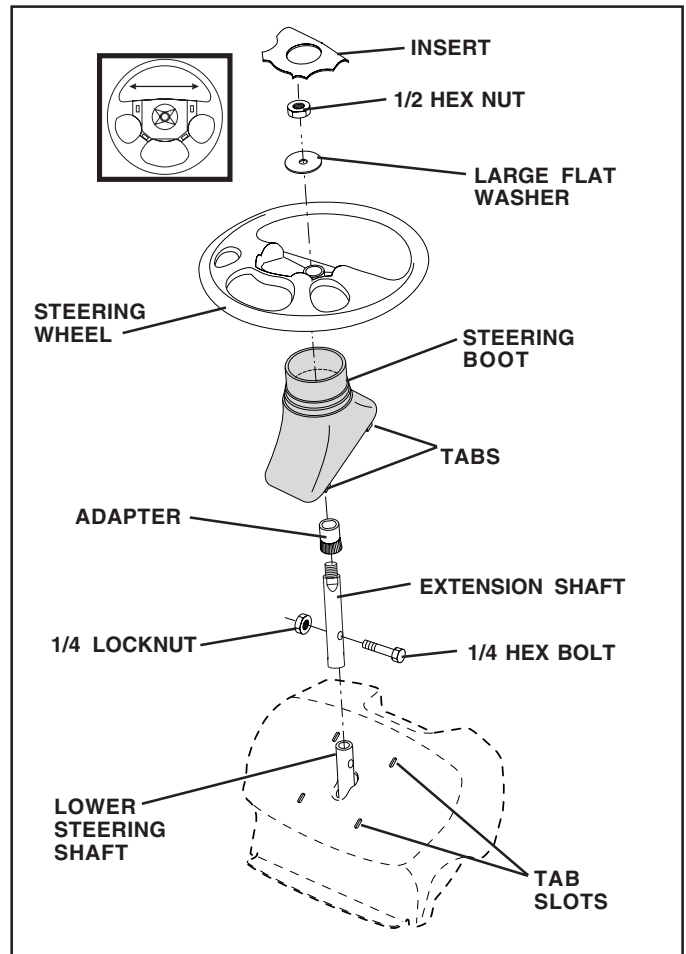

FIG. 1

## HOW TO SET UP YOUR TRACTOR

### CHECK BATTERY (See Fig. 2)

- Lift seat pan to raised position.
- If this battery is put into service after month and year indicated on label (label located between terminals) charge battery for minimum of one hour at 6-10 amps. (See "BATTERY" in the Customer Responsibilities section of this manual for charging instructions).

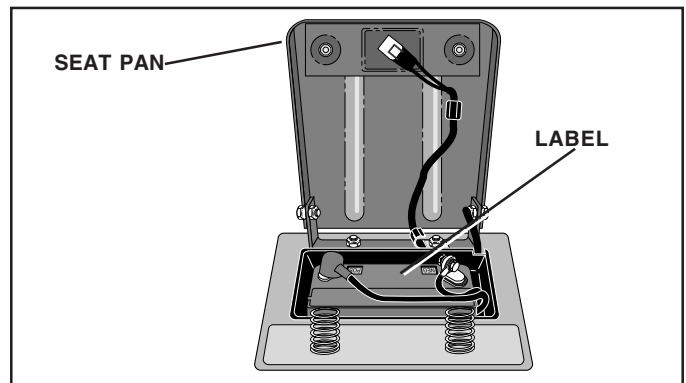

FIG. 2

# ASSEMBLY

## INSTALL SEAT (See Fig. 3)

Adjust seat before tightening adjustment bolt.

- Remove adjustment bolt, lock washer and flat washer securing seat to cardboard packing and set aside for assembly of seat to tractor.
- Pivot seat upward and remove from the cardboard packing. Remove the cardboard packing and discard.
- Place seat on seat pan so head of shoulder bolt is positioned over large slotted hole in pan.
- Push down on seat to engage shoulder bolt in slot and pull seat towards rear of tractor.
- Pivot seat and pan forward and assemble adjustment bolt, lockwasher and flat washer loosely. Do not tighten.
- Lower seat into operating position and sit on seat.
- Slide seat until a comfortable position is reached which allows you to press clutch/brake pedal all the way down.
- Get off seat without moving its adjusted position.
- Raise seat and tighten adjustment bolt securely.

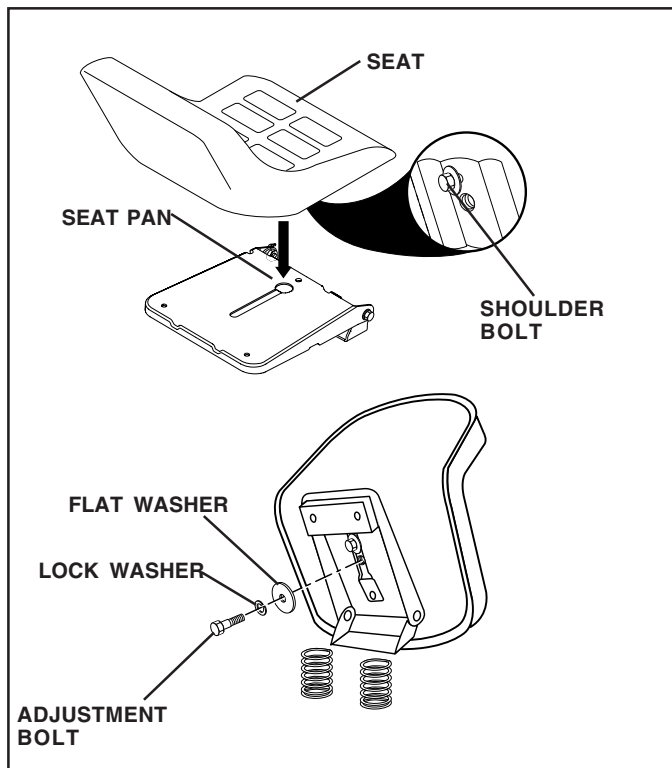

FIG. 3

**NOTE:** You may now roll or drive your tractor off the skid. Follow the appropriate instruction below to remove the tractor from the skid.

## TO ROLL TRACTOR OFF SKID (See Operation section, page 10, for location and function of controls)

- Press lift lever plunger and raise attachment lift lever to its highest position.
- Release parking brake by depressing clutch/brake pedal.
- Place freewheel control in freewheeling position to disengage transmission (See "TO TRANSPORT" in the Operation section of this manual).
- Roll tractor forward off skid.
- Remove banding holding deflector shield up against tractor.

## TO DRIVE TRACTOR OFF SKID (See Operation section, page 10, for location and function of controls)

**⚠WARNING:** Before starting, read, understand and follow all instructions in the Operation section of this manual. Be sure tractor is in a well-ventilated area. Be sure the area in front of tractor is clear of other people and objects.

- Be sure all the above assembly steps have been completed.
- Check engine oil level and fill fuel tank with gasoline.
- Place freewheel control in "transmission engaged" position.
- Sit on seat in operating position, depress clutch/brake pedal and set the parking brake.
- Place motion control lever in neutral (N) position.
- Press lift lever plunger and raise attachment lift lever to its highest position.
- Start the engine. After engine has started, move throttle control to idle position.
- Release parking brake.
- Slowly move the motion control lever forward and slowly drive tractor off skid.
- Apply brake to stop tractor, set parking brake and place motion control lever in neutral position.
- Turn ignition key to "OFF" position.

Continue with the instructions that follow.

---

# ASSEMBLY

---

## CHECK TIRE PRESSURE

The tires on your tractor were overinflated at the factory for shipping purposes. Correct tire pressure is important for best cutting performance.

- Reduce tire pressure to PSI shown in "PRODUCT SPECIFICATIONS" section of this manual.

## CHECK DECK LEVELNESS

For best cutting results, mower housing should be properly leveled. See "TO LEVEL MOWER HOUSING" in the Service and Adjustments section of this manual.

## CHECK FOR PROPER POSITION OF ALL BELTS

See the figures that are shown for replacing motion and mower blade drive belts in the Service and Adjustments section of this manual. Verify that the belts are routed correctly.

## CHECK BRAKE SYSTEM

After you learn how to operate your tractor, check to see that the brake is properly adjusted. See "TO ADJUST BRAKE" in the Service and Adjustments section of this manual.

## ✓ CHECKLIST

*BEFORE YOU OPERATE AND ENJOY YOUR NEW TRACTOR, WE WISH TO ASSURE THAT YOU RECEIVE THE BEST PERFORMANCE AND SATISFACTION FROM THIS QUALITY PRODUCT.*

*PLEASE REVIEW THE FOLLOWING CHECKLIST:*

- ✓ All assembly instructions have been completed.
- ✓ No remaining loose parts in carton.
- ✓ Battery is properly prepared and charged. (Minimum 1 hour at 6 amps).
- ✓ Seat is adjusted comfortably and tightened securely.
- ✓ All tires are properly inflated. (For shipping purposes, the tires were overinflated at the factory).
- ✓ Be sure mower deck is properly leveled side-to-side/front-to-rear for best cutting results. (Tires must be properly inflated for leveling).
- ✓ Check mower and drive belts. Be sure they are routed properly around pulleys and inside all belt keepers.
- ✓ Check wiring. See that all connections are still secure and wires are properly clamped.
- ✓ Before driving tractor, be sure freewheel control is in drive position.

*WHILE LEARNING HOW TO USE YOUR TRACTOR, PAY EXTRA ATTENTION TO THE FOLLOWING IMPORTANT ITEMS:*

- ✓ Engine oil is at proper level.
- ✓ Fuel tank is filled with fresh, clean, regular unleaded gasoline.
- ✓ Become familiar with all controls - their location and function. Operate them before you start the engine.
- ✓ Be sure brake system is in safe operating condition.
- ✓ It is important to purge the transmission before operating your tractor for the first time. Follow proper starting and transmission purging instructions (See "TO START ENGINE" and "PURGE TRANSMISSION" in the Operation section of this manual).



# OPERATION

These symbols may appear on your tractor or in literature supplied with the product. Learn and understand their meaning.



BATTERY



CAUTION OR WARNING



REVERSE



FORWARD



FAST



SLOW



ENGINE ON



ENGINE OFF



OIL PRESSURE

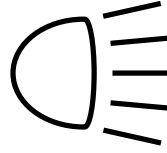

LIGHTS ON



OVER TEMP LIGHT

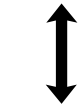

MOWER LIFT



FUEL

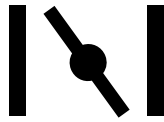

CHOKE

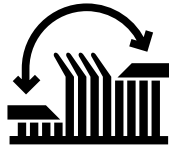

MOWER HEIGHT



PARKING BRAKE LOCKED



UNLOCKED



ATTACHMENT CLUTCH ENGAGED

R

REVERSE

N

NEUTRAL

H

HIGH

L

LOW

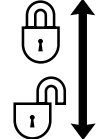

PARKING BRAKE

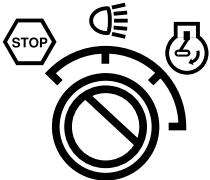

IGNITION

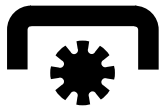

ATTACHMENT CLUTCH DISENGAGED



KEEP AREA CLEAR



SLOPE HAZARDS

(SEE SAFETY RULES SECTION)



DANGER, KEEP HANDS AND FEET AWAY

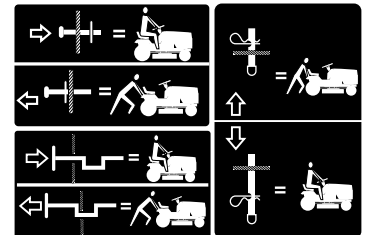

FREE WHEEL  
(Automatic Models only)

# OPERATION

## KNOW YOUR TRACTOR

### READ THIS OWNER'S MANUAL AND SAFETY RULES BEFORE OPERATING YOUR TRACTOR

Compare the illustrations with your tractor to familiarize yourself with the locations of various controls and adjustments. Save this manual for future reference.

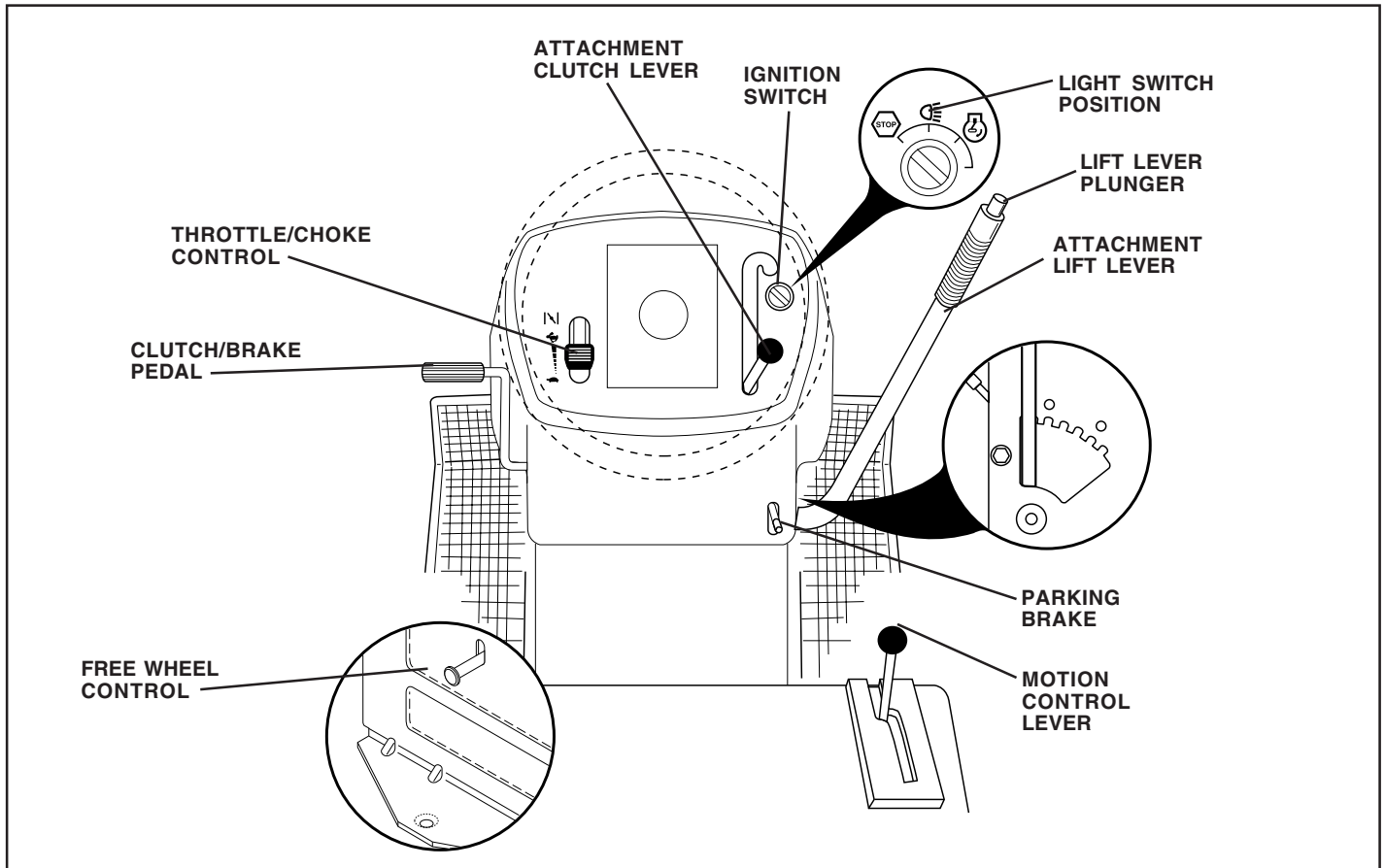

FIG. 4

Our tractors conform to the safety standards of the American National Standards Institute.

**ATTACHMENT CLUTCH LEVER:** Used to engage the mower blades, or other attachments mounted to your tractor.

**LIGHT SWITCH POSITION:** Turns the headlights on and off.

**THROTTLE/CHOKE CONTROL:** Used for starting and controlling engine speed.

**CLUTCH/BRAKE PEDAL:** Used for declutching and braking the tractor and starting the engine.

**PARKING BRAKE:** Locks clutch/brake pedal into the brake position.

**FREEWHEEL CONTROL:** Disengages transmission for pushing or slowly towing the tractor with the engine off.

**MOTION CONTROL LEVER:** Selects the speed and direction of tractor.

**ATTACHMENT LIFT LEVER:** Used to raise and lower the mower deck or other attachments mounted to your tractor.

**LIFT LEVER PLUNGER:** Used to release attachment lift lever when changing its position.

**IGNITION SWITCH:** Used for starting and stopping the engine.

# OPERATION



The operation of any tractor can result in foreign objects thrown into the eyes, which can result in severe eye damage. Always wear safety glasses or eye shields while operating your tractor or performing any adjustments or repairs. We recommend a wide vision safety mask over spectacles or standard safety glasses.

## HOW TO USE YOUR TRACTOR

### TO SET PARKING BRAKE (See Fig. 5)

Your tractor is equipped with an operator presence sensing switch. When engine is running, any attempt by the operator to leave the seat without first setting the parking brake will shut off the engine.

- Depress clutch/brake pedal into full "BRAKE" position and hold.
- Place parking brake lever in "ENGAGED" position and release pressure from clutch/brake pedal. Pedal should remain in "BRAKE" position. Make sure parking brake will hold tractor secure.

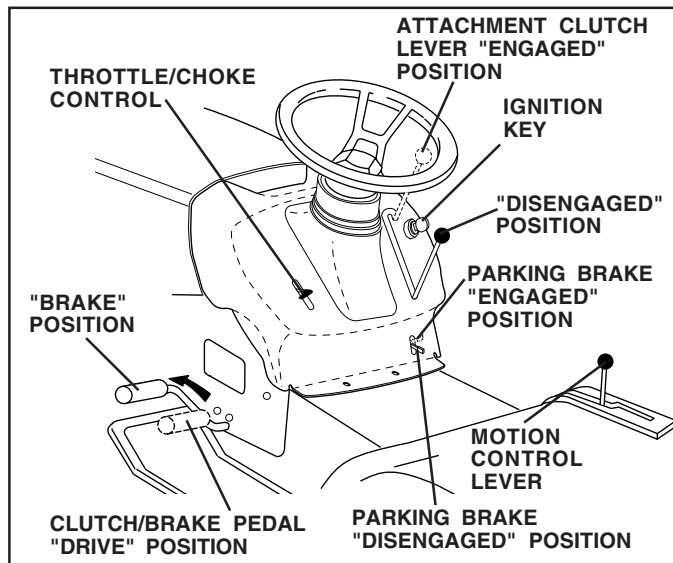

FIG. 5

### STOPPING (See Fig. 5)

#### MOWER BLADES -

- To stop mower blades, move attachment clutch lever to "DISENGAGED" position.

#### GROUND DRIVE -

- To stop ground drive, depress clutch/brake pedal into full "BRAKE" position.
- Move motion control lever to neutral (N) position.

**IMPORTANT:** THE MOTION CONTROL LEVER DOES NOT RETURN TO NEUTRAL (N) POSITION WHEN THE CLUTCH/BRAKE PEDAL IS DEPRESSED.

#### ENGINE -

- Move throttle control to slow position.

**NOTE:** Failure to move throttle control to slow position and allowing engine to idle before stopping may cause engine to "backfire".

- Turn ignition key to "OFF" position and remove key. Always remove key when leaving tractor to prevent unauthorized use.
- Never use choke to stop engine.

**IMPORTANT:** LEAVING THE IGNITION SWITCH IN ANY POSITION OTHER THAN "OFF" WILL CAUSE THE BATTERY TO BE DISCHARGED, (DEAD).

**NOTE:** Under certain conditions when tractor is standing idle with the engine running, hot engine exhaust gases may cause "browning" of grass. To eliminate this possibility, always stop engine when stopping tractor on grass areas.



**CAUTION:** Always stop tractor completely, as described above, before leaving the operator's position; to empty grass catcher, etc.

### TO USE THROTTLE CONTROL (See Fig. 5)

Always operate engine at full throttle.

- Operating engine at less than full throttle reduces the battery charging rate.
- Full throttle offers the best bagging and mower performance.

### TO MOVE FORWARD AND BACKWARD (See Fig. 5)

The direction and speed of movement is controlled by the motion control lever.

- Start tractor with motion control lever in neutral (N) position.
- Release parking brake.
- Slowly move motion control lever to desired position.

### TO ADJUST MOWER CUTTING HEIGHT (See Fig. 5)

The position of the attachment lift lever determines the cutting height.

- Grasp lift lever.
- Press plunger with thumb and move lever to desired position.

The cutting height range is approximately 1-1/2 to 4". The heights are measured from the ground to the blade tip with the engine not running. These heights are approximate and may vary depending upon soil conditions, height of grass and types of grass being mowed.

- The average lawn should be cut to approximately 2-1/2 inches during the cool season and to over 3 inches during hot months. For healthier and better looking lawns, mow often and after moderate growth.
- For best cutting performance, grass over 6 inches in height should be mowed twice. Make the first cut relatively high; the second to desired height.

# OPERATION

## TO OPERATE MOWER (See Fig. 6)

Your tractor is equipped with an operator presence sensing switch. Any attempt by the operator to leave the seat with the engine running and the attachment clutch engaged will shut off the engine.

- Select desired height of cut.
- Start mower blades by engaging attachment clutch control.
- TO STOP MOWER BLADES - disengage attachment clutch control.

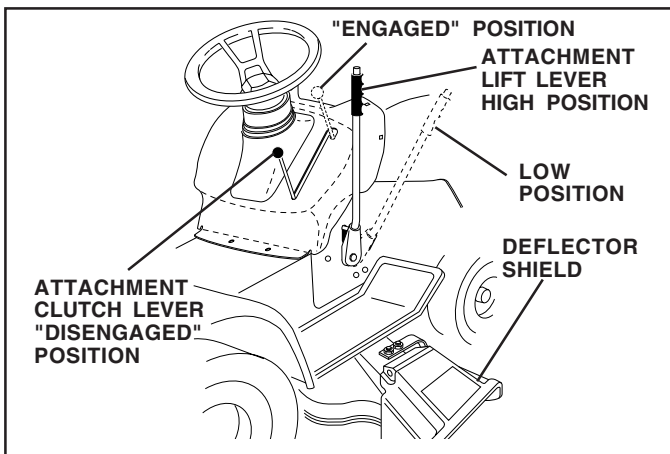
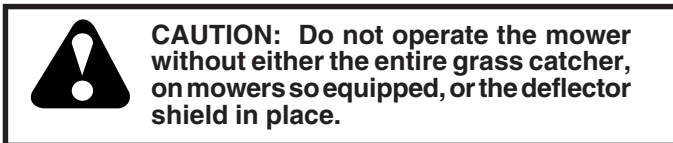

FIG. 6

## TO OPERATE ON HILLS



- Choose the slowest speed before starting up or down hills.
- Avoid stopping or changing speed on hills.
- If slowing is necessary, move throttle control lever to slower position.
- If stopping is absolutely necessary, push clutch/brake pedal quickly to brake position and engage parking brake.
- Move motion control lever to neutral (N) position.

**IMPORTANT:** THE MOTION CONTROL LEVER DOES NOT RETURN TO NEUTRAL (N) POSITION WHEN THE CLUTCH/BRAKE PEDAL IS DEPRESSED.

- To restart movement, slowly release parking brake and clutch/brake pedal.
- Slowly move motion control lever to slowest setting.
- Make all turns slowly.

## TO TRANSPORT (See Figs. 4 and 7)

When pushing or towing your tractor, be sure to disengage transmission by placing freewheel control in freewheeling position. Free wheel control is located at the rear drawbar of tractor.

- Raise attachment lift to highest position with attachment lift control.
- Pull freewheel control out and down into the slot and release so it is held in the disengaged position.
- Do not push or tow tractor at more than two (2) MPH.
- To reengage transmission, reverse above procedure.

**NOTE:** To protect hood from damage when transporting your tractor on a truck or a trailer, be sure hood is closed and secured to tractor. Use an appropriate means of tying hood to tractor (rope, cord, etc.).

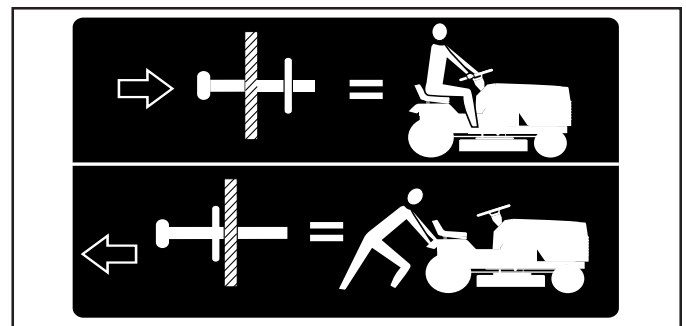

FIG. 7

## TOWING CARTS AND OTHER ATTACHMENTS

Tow only the attachments that are recommended by and comply with specifications of the manufacturer of your tractor. Use common sense when towing. Too heavy of a load, while on a slope, is dangerous. Tires can lose traction with the ground and cause you to lose control of your tractor.

## BEFORE STARTING THE ENGINE

### CHECK ENGINE OIL LEVEL

- The engine in your tractor has been shipped, from the factory, already filled with summer weight oil.
- Check engine oil with tractor on level ground.
- Remove oil fill cap/dipstick and wipe clean, reinsert the dipstick and screw cap tight, wait for a few seconds, remove and read oil level. If necessary, add oil until "FULL" mark on dipstick is reached. Do not overfill.
- For cold weather operation you should change oil for easier starting (See "OIL VISCOSITY CHART" in the Customer Responsibilities section of this manual).
- To change engine oil, see the Customer Responsibilities section in this manual.

# OPERATION

## ADD GASOLINE

- Fill fuel tank to bottom of filler neck. Do not overfill. Use fresh, clean, regular unleaded gasoline with a minimum of 87 octane. (Use of leaded gasoline will increase carbon and lead oxide deposits and reduce valve life). Do not mix oil with gasoline. Purchase fuel in quantities that can be used within 30 days to assure fuel freshness.



**CAUTION: Wipe off any spilled oil or fuel. Do not store, spill or use gasoline near an open flame.**

**IMPORTANT:** WHEN OPERATING IN TEMPERATURES BELOW 32°F (0°C), USE FRESH, CLEAN WINTER GRADE GASOLINE TO HELP INSURE GOOD COLD WEATHER STARTING.



**CAUTION: Alcohol blended fuels (called gasohol or using ethanol or methanol) can attract moisture which leads to separation and formation of acids during storage. Acidic gas can damage the fuel system of an engine while in storage. To avoid engine problems, the fuel system should be emptied before storage of 30 days or longer. Drain the gas tank, start the engine and let it run until the fuel lines and carburetor are empty. Use fresh fuel next season. See Storage Instructions for additional information. Never use engine or carburetor cleaner products in the fuel tank or permanent damage may occur.**

## TO START ENGINE (See Fig. 4)

When starting the engine for the first time or if the engine has run out of fuel, it will take extra cranking time to move fuel from the tank to the engine.

- Be sure freewheel control is in the transmission engaged position.
- Sit on seat in operating position, depress clutch/brake pedal and set parking brake.
- Place motion control lever in neutral (N) position.
- Move attachment clutch to “DISENGAGED” position.
- Move throttle control to choke position.

**NOTE:** Before starting, read the warm and cold starting procedures below.

- Insert key into ignition and turn key clockwise to “START” position and release key as soon as engine starts. Do not run starter continuously for more than fifteen seconds per minute. If the engine does not start after several attempts, move throttle control to fast position, wait a few minutes and try again. If engine still does not start, move the throttle control back to the choke position and retry.

## WARM WEATHER STARTING (50° F and above)

- When engine starts, move the throttle control to the fast position.
- The attachments and ground drive can now be used. If the engine does not accept the load, restart the engine and allow it to warm up for one minute using the choke as described above.

## COLD WEATHER STARTING ( 50° F and below)

- When engine starts, allow engine to run with the throttle control in the choke position until the engine runs roughly, then move throttle control to fast position. This may require an engine warm-up period from several seconds to several minutes, depending on the temperature.

## AUTOMATIC TRANSMISSION WARM UP

- Before driving the unit in cold weather, the transmission should be warmed up as follows:
  - Be sure the tractor is on level ground.
  - Place the motion control lever in neutral. Release the parking brake and let the clutch/brake slowly return to operating position.
  - Allow one minute for transmission to warm up. This can be done during the engine warm up period.
- The attachments can also be used during the engine warm-up period after the transmission has been warmed up.

**NOTE:** If at a high altitude (above 3000 feet) or in cold temperatures (below 32 F) the carburetor fuel mixture may need to be adjusted for best engine performance. See “TO ADJUST CARBURETOR” in the Service and Adjustments section of this manual.

## PURGE TRANSMISSION



**CAUTION: Never engage or disengage freewheel lever while the engine is running.**

To ensure proper operation and performance, it is recommended that the transmission be purged before operating tractor for the first time. This procedure will remove any trapped air inside the transmission which may have developed during shipping of your tractor.

**IMPORTANT:** SHOULD YOUR TRANSMISSION REQUIRE REMOVAL FOR SERVICE OR REPLACEMENT, IT SHOULD BE PURGED AFTER REINSTALLATION BEFORE OPERATING THE TRACTOR.

- Place tractor safely on level surface with engine off and parking brake set.
- Disengage transmission by placing freewheel control in freewheeling position (See “TO TRANSPORT” in this section of manual).
- Sitting in the tractor seat, start engine. After the engine is running, move throttle control to slow position. With motion control lever in neutral (N) position, slowly disengage clutch/brake pedal.
- Move motion control lever to full forward position and hold for five (5) seconds. Move lever to full reverse position and hold for five (5) seconds. Repeat this procedure three (3) times.

# OPERATION

**NOTE:** During this procedure there will be no movement of drive wheels. The air is being removed from hydraulic drive system.

- Move motion control lever to neutral (N) position. Shut-off engine and set parking brake.
- Engage transmission by placing freewheel control in driving position (See "TO TRANSPORT" in this section of manual).
- Sitting in the tractor seat, start engine. After the engine is running, move throttle control to half (1/2) speed. With motion control lever in neutral (N) position, slowly disengage clutch/brake pedal.
- Slowly move motion control lever forward, after the tractor moves approximately five (5) feet, slowly move motion control lever to reverse position. After the tractor moves approximately five (5) feet return the motion control lever to the neutral (N) position. Repeat this procedure with the motion control lever three (3) times.
- Your tractor is now purged and now ready for normal operation.

## MOWING TIPS

- Mower should be properly leveled for best mowing performance. See "TO LEVEL MOWER HOUSING" in the Service and Adjustments section of this manual.
- The left hand side of mower should be used for trimming.
- Drive so that clippings are discharged onto the area that has been cut. Have the cut area to the right of the machine. This will result in a more even distribution of clippings and more uniform cutting.
- When mowing large areas, start by turning to the right so that clippings will discharge away from shrubs, fences, driveways, etc. After one or two rounds, mow in the opposite direction making left hand turns until finished (See Fig. 8).
- If grass is extremely tall, it should be mowed twice to reduce load and possible fire hazard from dried clippings. Make first cut relatively high; the second to the desired height.
- Do not mow grass when it is wet. Wet grass will plug mower and leave undesirable clumps. Allow grass to dry before mowing.
- **Always operate engine at full throttle when mowing** to assure better mowing performance and proper discharge of material. Regulate ground speed by selecting a low enough gear to give the mower cutting performance as well as the quality of cut desired.
- When operating attachments, select a ground speed that will suit the terrain and give best performance of the attachment being used.

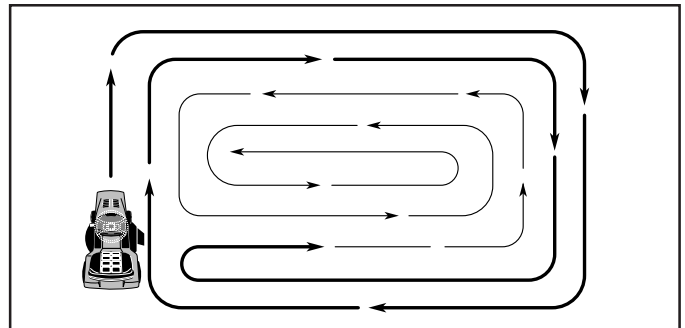

FIG. 8

# CUSTOMER RESPONSIBILITIES

MAINTENANCE SCHEDULE FILL IN DATES AS YOU COMPLETE REGULAR SERVICE		SERVICE DATES								
		BEFORE EACH USE	EVERY 8 HOURS	EVERY 25 HOURS	EVERY 50 HOURS	EVERY 100 HOURS	EVERY SEASON	BEFORE STORAGE		
TRACTOR	Check Brake Operation	✓	✓							
	Check Tire Pressure	✓	✓							
	Check Operator Presence and Interlock Systems	✓								
	Check for Loose Fasteners	✓				✓ <sub>5</sub>	✓			
	Sharpen/Replace Mower Blades			✓ <sub>3</sub>						
	Lubrication Chart			✓			✓			
	Check Battery Level			✓ <sub>4</sub>						
	Clean Battery and Terminals			✓			✓			
	Check Transaxle Cooling			✓						
	Check V-Belts					✓				
ENGINE	Check Engine Oil Level	✓	✓							
	Change Engine Oil (with oil filter)				✓ <sub>1,2</sub>		✓			
	Change Engine Oil (without oil filter)			✓ <sub>1,2</sub>			✓			
	Clean Air Filter			✓ <sub>2</sub>						
	Clean Air Screen			✓ <sub>2</sub>						
	Inspect Muffler/Spark Arrester				✓					
	Replace Oil Filter (If equipped)					✓ <sub>1,2</sub>				
	Clean Engine Cooling Fins					✓ <sub>2</sub>				
	Replace Spark Plug					✓	✓			
	Replace Air Filter Paper Cartridge					✓ <sub>2</sub>				
Replace Fuel Filter						✓				

1 - Change more often when operating under a heavy load or in high ambient temperatures.  
2 - Service more often when operating in dirty or dusty conditions.

3 - Replace blades more often when mowing in sandy soil.  
4 - Not required if equipped with maintenance-free battery.  
5 - Tighten front axle pivot bolt to 35 ft.-lbs. maximum. Do not overtighten.

## GENERAL RECOMMENDATIONS

The warranty on this tractor does not cover items that have been subjected to operator abuse or negligence. To receive full value from the warranty, operator must maintain tractor as instructed in this manual.

Some adjustments will need to be made periodically to properly maintain your tractor.

All adjustments in the Service and Adjustments section of this manual should be checked at least once each season.

- Once a year you should replace the spark plug, clean or replace air filter, and check blades and belts for wear. A new spark plug and clean air filter assure proper air-fuel mixture and help your engine run better and last longer.

## BEFORE EACH USE

- Check engine oil level.
- Check brake operation.
- Check tire pressure.
- Check operator presence and interlock systems for proper operation.
- Check for loose fasteners.

## LUBRICATION CHART

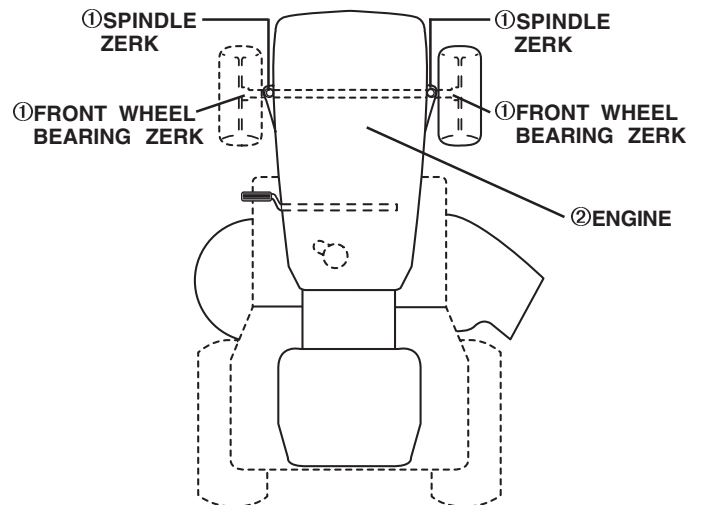

①SAE 30 OR 10W30 MOTOR OIL

②REFER TO CUSTOMER RESPONSIBILITIES "ENGINE" SECTION

**IMPORTANT:** DO NOT OIL OR GREASE THE PIVOT POINTS WHICH HAVE SPECIAL NYLON BEARINGS. VISCOUS LUBRICANTS WILL ATTRACT DUST AND DIRT THAT WILL SHORTEN THE LIFE OF THE SELF-LUBRICATING BEARINGS. IF YOU FEEL THEY MUST BE LUBRICATED, USE ONLY A DRY, POWDERED GRAPHITE TYPE LUBRICANT SPARINGLY.

# CUSTOMER RESPONSIBILITIES

## TRACTOR

Always observe safety rules when performing any maintenance.

### BRAKE OPERATION

If tractor requires more than six (6) feet stopping distance at high speed in highest gear, then brake must be adjusted. (See "TO ADJUST BRAKE" in the Service and Adjustments section of this manual).

### TIRES

- Maintain proper air pressure in all tires (See "PRODUCT SPECIFICATIONS" section of this manual).
- Keep tires free of gasoline, oil, or insect control chemicals which can harm rubber.
- Avoid stumps, stones, deep ruts, sharp objects and other hazards that may cause tire damage.

**NOTE:** To seal tire punctures and prevent flat tires due to slow leaks, tire sealant may be purchased from your local parts dealer. Tire sealant also prevents tire dry rot and corrosion.

### OPERATOR PRESENCE SYSTEM

Be sure operator presence and interlock systems are working properly. If your tractor does not function as described, repair the problem immediately.

- The engine should not start unless the clutch/brake pedal is fully depressed and attachment clutch control is in the disengaged position.
- When the engine is running, any attempt by the operator to leave the seat without first setting the parking brake should shut off the engine.
- When the engine is running and the attachment clutch is engaged, any attempt by the operator to leave the seat should shut off the engine.
- The attachment clutch should never operate unless the operator is in the seat.

### BLADE CARE

For best results mower blades must be kept sharp. Replace bent or damaged blades.

### BLADE REMOVAL (See Fig. 9)

- Raise mower to highest position to allow access to blades.
- Remove hex bolt, lock washer and flat washer securing blade.
- Install new or resharpened blade with trailing edge up towards deck as shown.

**IMPORTANT:** TO ENSURE PROPER ASSEMBLY, CENTER HOLE IN BLADE MUST ALIGN WITH STAR ON MANDREL ASSEMBLY.

- Reassemble hex bolt, lock washer and flat washer in exact order as shown.
- Tighten bolt securely (27-35 Ft. Lbs. torque).

**IMPORTANT:** BLADE BOLT IS GRADE 8 HEAT TREATED.

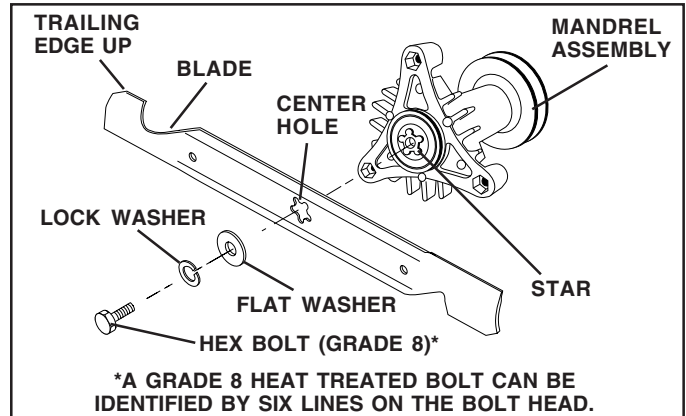

FIG. 9

### TO SHARPEN BLADE (See Fig. 10)

**NOTE:** We do not recommend sharpening blade - but if you do, be sure the blade is balanced.

Care should be taken to keep the blade balanced. An unbalanced blade will cause excessive vibration and eventual damage to mower and engine.

- The blade can be sharpened with a file or on a grinding wheel. Do not attempt to sharpen while on the mower.
- To check blade balance, you will need a 5/8" diameter steel bolt, pin, or a cone balancer. (When using a cone balancer, follow the instructions supplied with balancer).

**NOTE:** Do not use a nail for balancing blade. The lobes of the center hole may appear to be centered, but are not.

- Slide blade on to an unthreaded portion of the steel bolt or pin and hold the bolt or pin parallel with the ground. If blade is balanced, it should remain in a horizontal position. If either end of the blade moves downward, sharpen the heavy end until the blade is balanced.

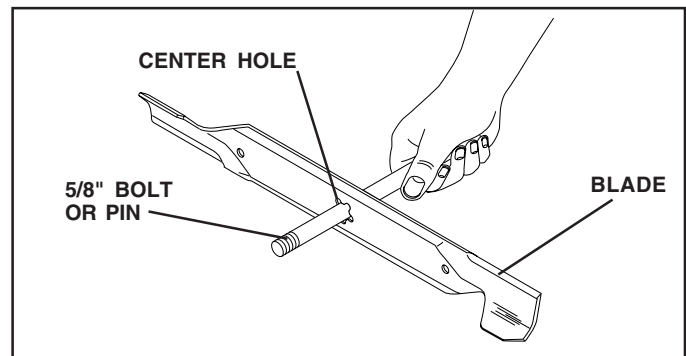

FIG. 10

### BATTERY

Your tractor has a battery charging system which is sufficient for normal use. However, periodic charging of the battery with an automotive charger will extend its life.

- Keep battery and terminals clean.
- Keep battery bolts tight.
- Keep small vent holes open.
- Recharge at 6-10 amperes for 1 hour.

**NOTE:** The original equipment battery on your tractor is maintenance free. Do not attempt to open or remove caps or covers. Adding or checking level of electrolyte is not necessary.



# CUSTOMER RESPONSIBILITIES

## TO CLEAN BATTERY AND TERMINALS

Corrosion and dirt on the battery and terminals can cause the battery to “leak” power.

- Disconnect BLACK battery cable first then RED battery cable and remove battery from tractor.
- Rinse the battery with plain water and dry.
- Clean terminals and battery cable ends with wire brush until bright.
- Coat terminals with grease or petroleum jelly.
- Reinstall battery (See “REPLACING BATTERY” in the SERVICE AND ADJUSTMENTS section of this manual).

## V-BELTS

Check V-belts for deterioration and wear after 100 hours of operation and replace if necessary. The belts are not adjustable. Replace belts if they begin to slip from wear.

## TRANSAXLE COOLING

The transmission fan and cooling fins should be kept clean to assure proper cooling.

Do not attempt to clean fan or transmission while engine is running or while the transmission is hot. To prevent possible damage to seals, do not use high pressure water or steam to clean transaxle.

- Inspect cooling fan to be sure fan blades are intact and clean.
- Inspect cooling fins for dirt, grass clippings and other materials. To prevent damage to seals, do not use compressed air or high pressure sprayer to clean cooling fins.

## TRANSAXLE PUMP FLUID

The transaxle was sealed at the factory and fluid maintenance is not required for the life of the transaxle. Should the transaxle ever leak or require servicing, contact your nearest authorized service center/department.

## ENGINE

### LUBRICATION

Only use high quality detergent oil rated with API service classification SF-SJ. Select the oil's SAE viscosity grade according to your expected operating temperature.

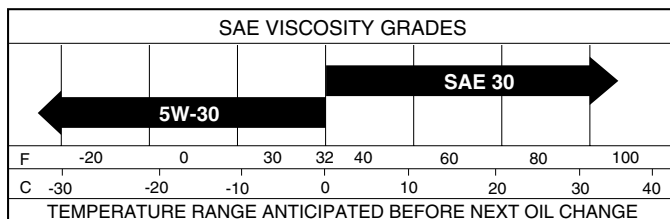

FIG. 11

**NOTE:** Although multi-viscosity oils (5W30, 10W30 etc.) improve starting in cold weather, these multi-viscosity oils will result in increased oil consumption when used above 32°F. Check your engine oil level more frequently to avoid possible engine damage from running low on oil.

Change the oil after every 25 hours of operation or at least once a year if the tractor is not used for 25 hours in one year.

Check the crankcase oil level before starting the engine and after each eight (8) hours of operation. Tighten oil fill cap/dipstick securely each time you check the oil level.

## TO CHANGE ENGINE OIL (See Figs. 11 and 12)

Determine temperature range expected before oil change. All oil must meet API service classification SF-SJ.

- Be sure tractor is on level surface.
- Oil will drain more freely when warm.
- Catch oil in a suitable container.
- Remove oil fill cap/dipstick. Be careful not to allow dirt to enter the engine when changing oil.
- Remove yellow cap from bottom fitting of drain valve and install the drain tube onto the fitting.

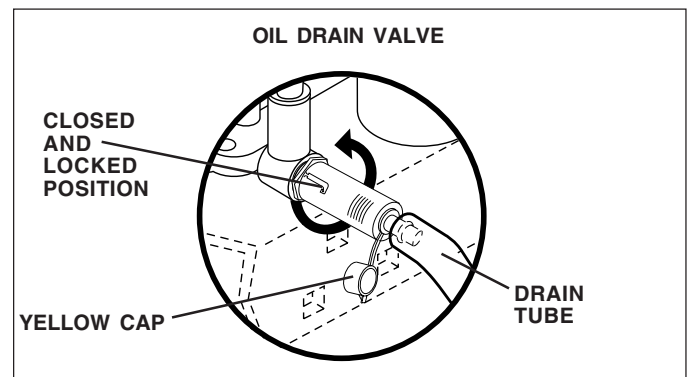

FIG. 12

- Unlock drain valve by pushing inward and turning counterclockwise.
- To open, pull out on the drain valve.
- After oil has drained completely, close and lock the drain valve by pushing inward and turning clockwise until the pin is in the locked position as shown.
- Remove the drain tube and replace the cap onto to the bottom fitting of the drain valve.
- Refill engine with oil through oil fill dipstick tube. Pour slowly. Do not overfill. For approximate capacity see “PRODUCT SPECIFICATIONS” section of this manual.
- Use gauge on oil fill cap/dipstick for checking level. Be sure dipstick cap is tightened securely for accurate reading. Keep oil at “FULL” line on dipstick.

## CLEAN AIR SCREEN

Air screen must be kept free of dirt and chaff to prevent engine damage from overheating. Clean with a wire brush or compressed air to remove dirt and stubborn dried gum fibers.

# CUSTOMER RESPONSIBILITIES

## AIR FILTER (See Fig. 13)

Your engine will not run properly using a dirty air filter. Clean the foam pre-cleaner after every 25 hours of operation or every season. Service paper cartridge every 100 hours of operation or every season, whichever occurs first.

Service air cleaner more often under dusty conditions.

- Remove knob(s) and cover.

### TO SERVICE PRE-CLEANER

- Slide foam pre-cleaner off cartridge.
- Wash it in liquid detergent and water.
- Squeeze it dry in a clean cloth.
- Saturate it in engine oil. Wrap it in clean, absorbent cloth and squeeze to remove excess oil.
- If very dirty or damaged, replace pre-cleaner.
- Reinstall pre-cleaner over cartridge.
- Reinstall cover and secure with knob(s).

### TO SERVICE CARTRIDGE

- Remove cartridge nut.
- Carefully remove cartridge to prevent debris from entering carburetor. Clean base carefully to prevent debris from entering carburetor.
- Clean cartridge by tapping gently on flat surface. If very dirty or damaged, replace cartridge.
- Reinstall cartridge, nut, pre-cleaner, cover and secure with knob(s).

**IMPORTANT:** PETROLEUM SOLVENTS, SUCH AS KEROSENE, ARE NOT TO BE USED TO CLEAN THE CARTRIDGE. THEY MAY CAUSE DETERIORATION OF THE CARTRIDGE. DO NOT OIL CARTRIDGE. DO NOT USE PRESSURIZED AIR TO CLEAN OR DRY CARTRIDGE.

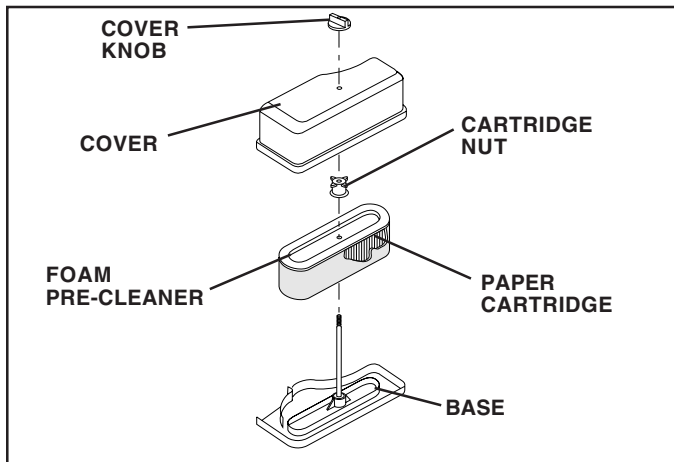

FIG. 13

## ENGINE COOLING FINS (See Fig. 14)

Remove any dust, dirt or oil from engine cooling fins to prevent engine damage from overheating.

- Remove screws from blower housing and lift housing and dipstick tube assembly off engine.
- Cover oil fill opening to prevent entry of dirt.
- Use compressed air or stiff bristle brush to thoroughly clean engine cooling fins.
- To reassemble, reverse above procedure.

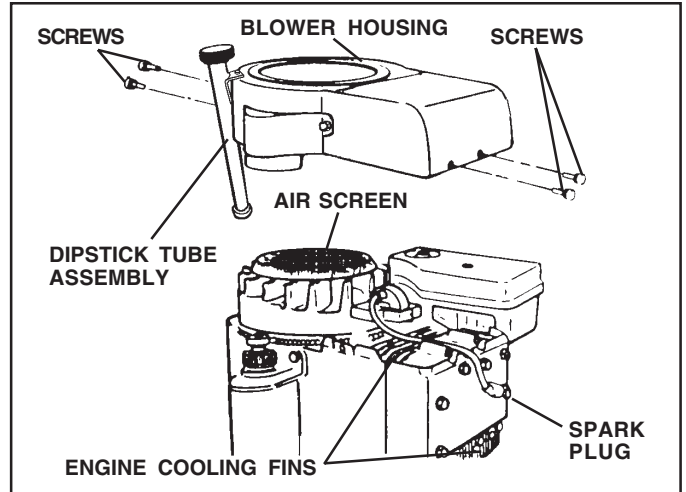

FIG. 14

## MUFFLER

Inspect and replace corroded muffler and spark arrester (if equipped) as it could create a fire hazard and/or damage.

## SPARK PLUGS

Replace spark plugs at the beginning of each mowing season or after every 100 hours of operation, whichever occurs first. Spark plug type and gap setting are shown in "PRODUCT SPECIFICATIONS" section of this manual.

## IN-LINE FUEL FILTER (See Fig. 15)

The fuel filter should be replaced once each season. If fuel filter becomes clogged, obstructing fuel flow to carburetor, replacement is required.

- With engine cool, remove filter and plug fuel line sections.
- Place new fuel filter in position in fuel line with arrow pointing towards carburetor.
- Be sure there are no fuel line leaks and clamps are properly positioned.
- Immediately wipe up any spilled gasoline.

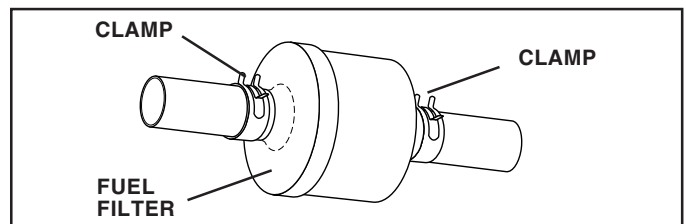

FIG. 15

## CLEANING

- Clean engine, battery, seat, finish, etc. of all foreign matter.
- Keep finished surfaces and wheels free of all gasoline, oil, etc.
- Protect painted surfaces with automotive type wax.

We do not recommend using a garden hose to clean your tractor unless the electrical system, muffler, air filter and carburetor are covered to keep water out. Water in engine can result in a shortened engine life.

# SERVICE AND ADJUSTMENTS



**WARNING: TO AVOID SERIOUS INJURY, BEFORE PERFORMING ANY SERVICE OR ADJUSTMENTS:**

- Depress clutch/brake pedal fully and set parking brake.
- Place motion control lever in neutral (N) position.
- Place attachment clutch in “DISENGAGED” position.
- Turn ignition key to “STOP” and remove key.
- Make sure the blades and all moving parts have completely stopped.
- Disconnect spark plug wire from spark plug and place wire where it cannot come in contact with plug.

## TRACTOR

### TO REMOVE MOWER (See Fig. 16)

Mower will be easier to remove from the right side of tractor.

- Place attachment clutch in “DISENGAGED” position.
- Move attachment lift lever forward to lower mower to its lowest position.
- Roll belt off engine pulley.
- Remove small retainer spring, and lift clutch spring off pulley bolt.
- Remove large retainer spring, slide collar off and push housing guide out of bracket.
- Disconnect anti-swaybar from chassis bracket by removing retainer spring.
- Disconnect suspension arms from rear deck brackets by removing retainer springs.
- Disconnect front links from deck by removing retainer springs.
- Raise lift lever to raise suspension arms. Slide mower out from under tractor.

**IMPORTANT:** IF AN ATTACHMENT OTHER THAN THE MOWER DECK IS TO BE MOUNTED ON THE TRACTOR, REMOVE THE FRONT LINKS AND HOOK THE CLUTCH SPRING INTO SQUARE HOLE IN FRAME.

### TO INSTALL MOWER (See Fig. 16)

- Raise attachment lift lever to its highest position.
- Slide mower under tractor with deflector shield to right side of tractor.
- Lower lift lever to its lowest position.
- Connect front links to mower deck and secure with retainer springs.
- Connect suspension arms to rear deck brackets and secure with retainer springs.
- Connect anti-swaybar to chassis bracket and secure with retainer spring.
- Push clutch cable housing guide into bracket, slide collar onto guide and secure with large retainer spring.
- Install belt onto engine pulley.

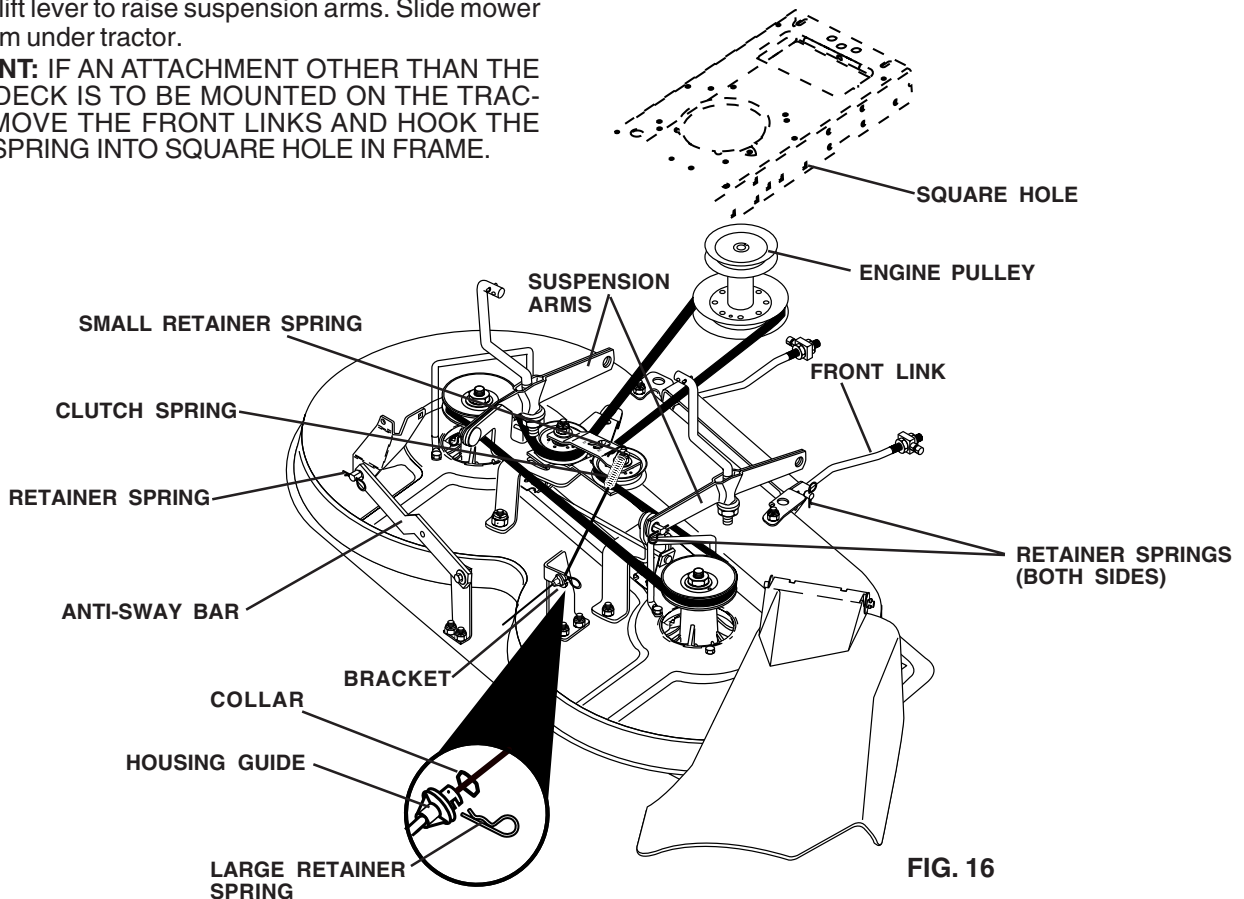

# SERVICE AND ADJUSTMENTS

## TO LEVEL MOWER HOUSING

Adjust the mower while tractor is parked on level ground or driveway. Make sure tires are properly inflated (See "PRODUCT SPECIFICATIONS" section of this manual). If tires are over or underinflated, you will not properly adjust your mower.

SIDE-TO-SIDE ADJUSTMENT (See Figs. 17 and 18)

- Raise mower to its highest position.
- At the midpoint of both sides of mower, measure height from bottom edge of mower to ground. Distance "A" on both sides of mower should be the same or within 1/4" of each other.
- If adjustment is necessary, make adjustment on one side of mower only.
- To raise one side of mower, tighten lift link adjustment nut on that side.
- To lower one side of mower, loosen lift link adjustment nut on that side.

**NOTE:** Three full turns of adjustment nut will change mower height about 1/8".

- Recheck measurements after adjusting.

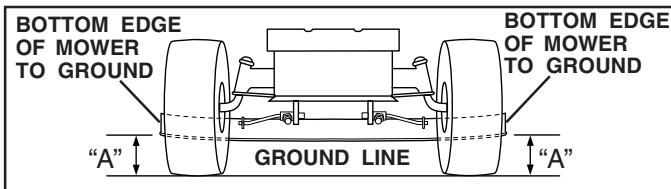

FIG. 17

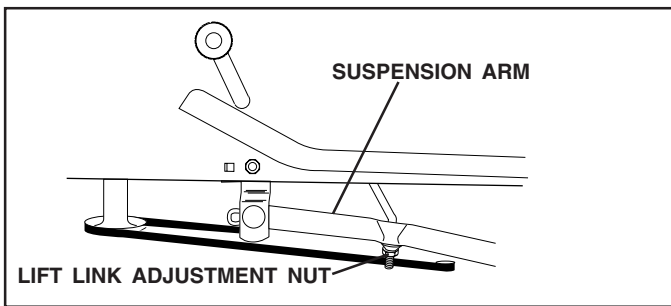

FIG. 18

FRONT-TO-BACK ADJUSTMENT (See Figs. 19 and 20)

**IMPORTANT:** DECK MUST BE LEVEL SIDE-TO-SIDE. IF THE FOLLOWING FRONT-TO-BACK ADJUSTMENT IS NECESSARY, BE SURE TO ADJUST BOTH FRONT LINKS EQUALLY SO MOWER WILL STAY LEVEL SIDE-TO-SIDE.

To obtain the best cutting results, the mower housing should be adjusted so that the front is approximately 1/8" to 1/2" lower than the rear when the mower is in its highest position.

Check adjustment on right side of tractor. Measure distance "D" directly in front and behind the mandrel at bottom edge of mower housing as shown.

- Before making any necessary adjustments, check that both front links are equal in length.
- If links are not equal in length, adjust one link to same length as other link.
- To lower front of mower loosen nut "E" on both front links an equal number of turns.

- When distance "D" is 1/8" to 1/2" lower at front than rear, tighten nuts "F" against trunnion on both front links.
- To raise front of mower, loosen nut "F" from trunnion on both front links. Tighten nut "E" on both front links an equal number of turns. The two front links must remain equal in length.
- When distance "D" is 1/8" to 1/2" lower at front than rear, tighten nut "F" against trunnion on both front links.
- Recheck side-to-side adjustment.

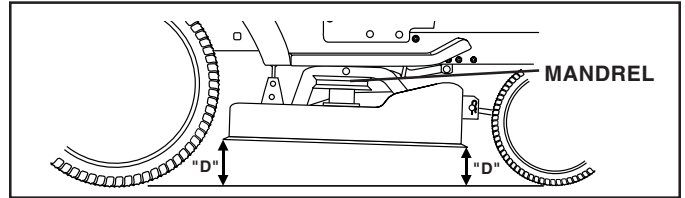

FIG. 19

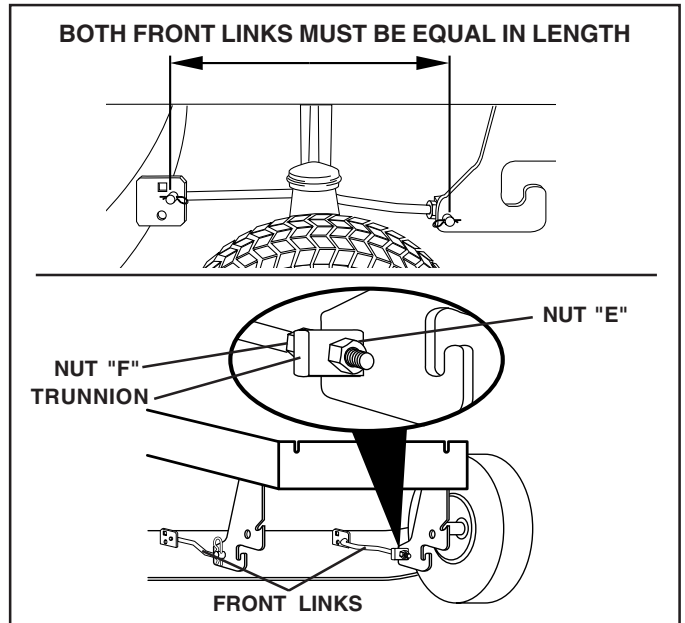

FIG. 20

## TO REPLACE MOWER BLADE DRIVE BELT (See Fig. 21)

The mower blade drive belt may be replaced without tools. Park the tractor on level surface. Engage parking brake.

BELT REMOVAL -

- Remove mower from tractor (See "TO REMOVE MOWER" in this section of this manual).
- Work belt off both mandrel pulleys and idler pulleys.
- Pull belt away from mower.

BELT INSTALLATION -

- Install new belt in reverse order of removal.
- Make sure belt is in all pulley grooves and inside all belt guides.
- Install mower in reverse order of removal instructions.

# SERVICE AND ADJUSTMENTS

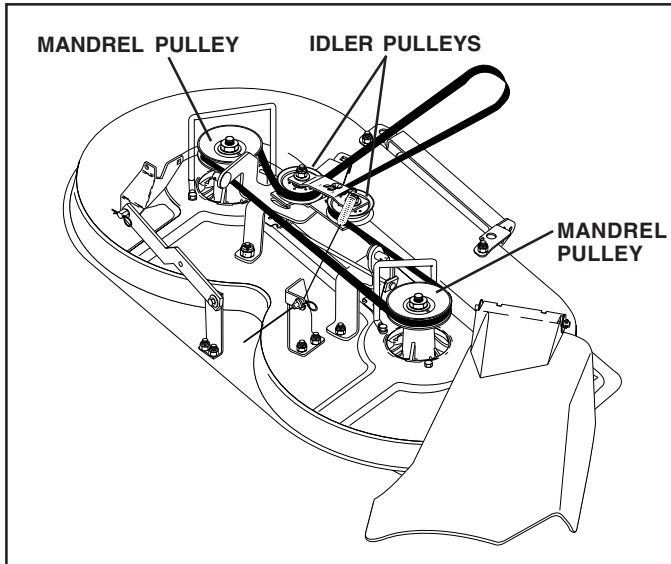

FIG. 21

## TO ADJUST BRAKE (See Fig. 22)

Your tractor is equipped with an adjustable brake system which is mounted on the side of the transaxle.

If tractor requires more than six (6) feet stopping distance at high speed in highest gear on a level dry concrete or paved surface, then brake must be adjusted.

- Depress clutch/brake pedal and engage parking brake.
- Measure distance between brake operating arm and nut "A" on brake rod.
- If distance is other than 1-9/16", loosen jam nut and turn nut "A" until distance becomes 1-9/16". Retighten jam nut against nut "A".
- Road test tractor for proper stopping distance as stated above. Readjust if necessary. If stopping distance is still greater than six (6) feet in highest gear, further maintenance is necessary. Contact your nearest authorized service center/department.

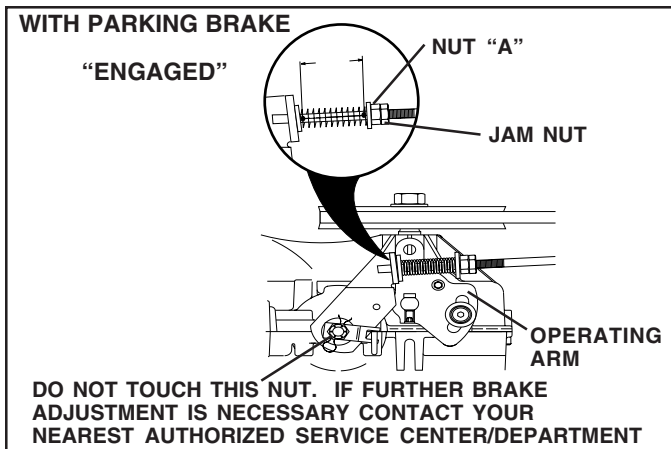

FIG. 22

## TO REPLACE MOTION DRIVE BELT (See Fig. 23)

Park the tractor on level surface. Engage parking brake. For assistance, there is a belt installation guide decal on bottom side of left footrest.

- Remove mower (See "TO REMOVE MOWER" in this section of this manual.)
- Remove belt from stationary idler and clutching idler.
- Pull belt slack toward rear of tractor. Carefully remove belt upwards from transmission input pulley and over cooling fan blades.
- Pull belt toward front of tractor and remove downward from around engine pulley.
- Install new belt by reversing above procedure.

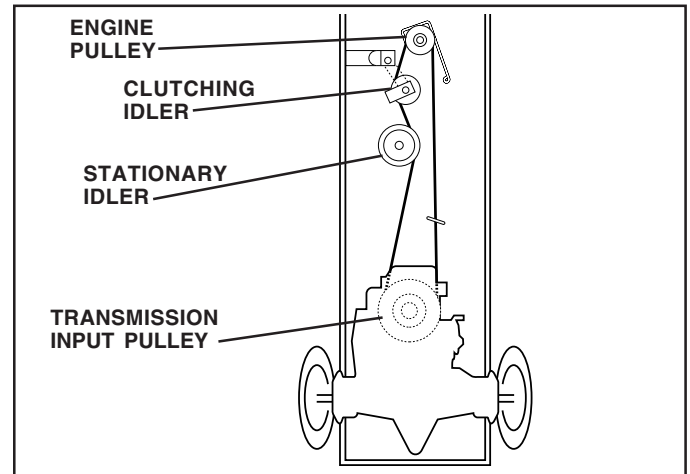

FIG. 23

## TRANSAXLE MOTION CONTROL LEVER NEUTRAL ADJUSTMENT (See Fig. 24)

The motion control lever has been preset at the factory and adjustment should not be necessary.

- Loosen adjustment bolt in front of the right rear wheel, and lightly tighten.
- Start engine and move motion control lever until tractor does not move forward or backward.
- Hold motion control lever in that position and turn engine off.
- While holding motion control lever in place, loosen the adjustment bolt.
- Move motion control lever to the neutral (N) (lock gate) position.
- Tighten adjustment bolt securely.

**NOTE:** If additional clearance is needed to get to adjustment bolt, move mower deck height to the lowest position.

After above adjustment is made, if the tractor still creeps forward or backward while motion control lever is in neutral position, follow these steps:

- Loosen the adjustment bolt.
- Move the motion control lever 1/4 to 1/2 inch in the direction it is trying to creep.
- Tighten adjustment bolt securely.
- Start engine and test.
- If tractor still creeps, repeat above steps until satisfied.

# SERVICE AND ADJUSTMENTS

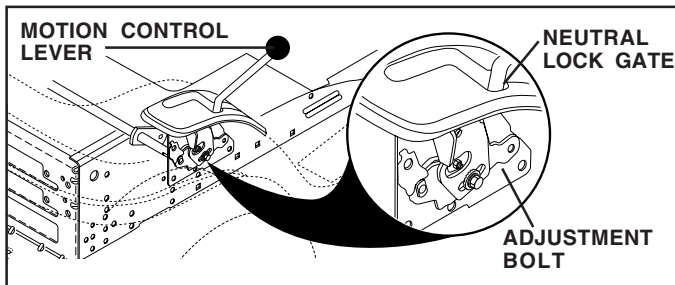

FIG. 24

## TRANSMISSION REMOVAL/REPLACEMENT

Should your transmission require removal for service or replacement, it should be purged after reinstallation and before operating the tractor. See "PURGE TRANSMISSION" in the Operation section of this manual.

## TO ADJUST STEERING WHEEL ALIGNMENT

If steering wheel crossbars are not horizontal (left to right) when wheels are positioned straight forward, remove steering wheel and reassemble per instructions in the Assembly section of this manual.

## FRONT WHEEL TOE-IN/CAMBER

The front wheel toe-in and camber are not adjustable on your tractor. If damage has occurred to affect the front wheel toe-in or camber, contact your nearest authorized service center/department.

## TO REMOVE WHEEL FOR REPAIRS (See Fig. 25)

- Block up axle securely.
- Remove axle cover, retaining ring and washers to allow wheel removal (rear wheel contains a square key - Do not lose).
- Repair tire and reassemble.
- On rear wheels only: align grooves in rear wheel hub and axle. Insert square key.
- Replace washers and snap retaining ring securely in axle groove.
- Replace axle cover.

**NOTE:** To seal tire punctures and prevent flat tires due to slow leaks, tire sealant may be purchased from your local parts dealer. Tire sealant also prevents tire dry rot and corrosion.

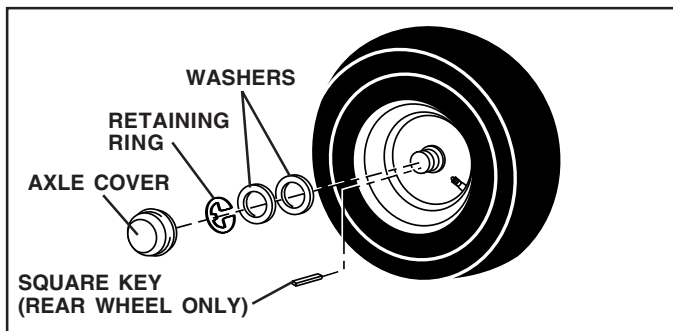

FIG. 25

## TO START ENGINE WITH A WEAK BATTERY (See Fig. 26)



**WARNING:** Lead-acid batteries generate explosive gases. Keep sparks, flame and smoking materials away from batteries. Always wear eye protection when around batteries.

If your battery is too weak to start the engine, it should be recharged. (See "BATTERY" in the MAINTENANCE section of this manual).

If "jumper cables" are used for emergency starting, follow this procedure:

**IMPORTANT:** YOUR TRACTOR IS EQUIPPED WITH A 12 VOLT SYSTEM. THE OTHER VEHICLE MUST ALSO BE A 12 VOLT SYSTEM. DO NOT USE YOUR TRACTOR BATTERY TO START OTHER VEHICLES.

### TO ATTACH JUMPER CABLES -

- Connect one end of the RED cable to the POSITIVE (+) terminal of each battery (A-B), taking care not to short against tractor chassis.
- Connect one end of the BLACK cable to the NEGATIVE (-) terminal (C) of fully charged battery.
- Connect the other end of the BLACK cable (D) to good chassis ground, away from fuel tank and battery.

### TO REMOVE CABLES, REVERSE ORDER -

- BLACK cable first from chassis and then from the fully charged battery.
- RED cable last from both batteries.

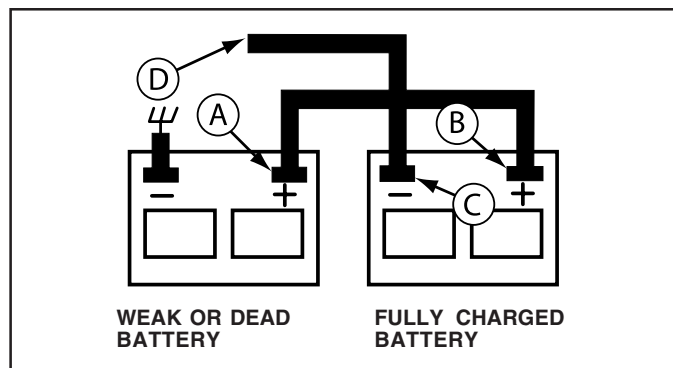

FIG. 26

## REPLACING BATTERY (See Fig. 27 and 28)



**CAUTION:** Do not short battery terminals by allowing a wrench or any other object to contact both terminals at the same time. Before connecting battery, remove metal bracelets, wristwatch bands, rings, etc. Positive terminal must be connected first to prevent sparking from accidental grounding.

- Lift seat pan to raised position.
- Disconnect BLACK battery cable first then RED battery cable and carefully remove battery from tractor.
- Install new battery with terminals in same position as old battery.

# SERVICE AND ADJUSTMENTS

- First connect RED battery cable to positive (+) terminal with hex bolt and keps nut as shown. Tighten securely. Slide terminal cover over terminal.
- Connect BLACK grounding cable to negative (-) terminal with remaining hex bolt and keps nut. Tighten securely.

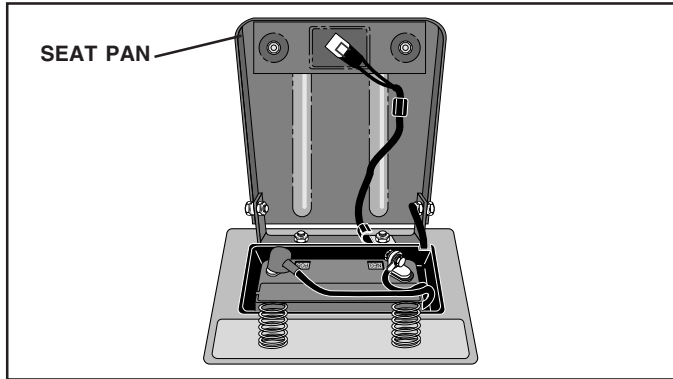

FIG. 27

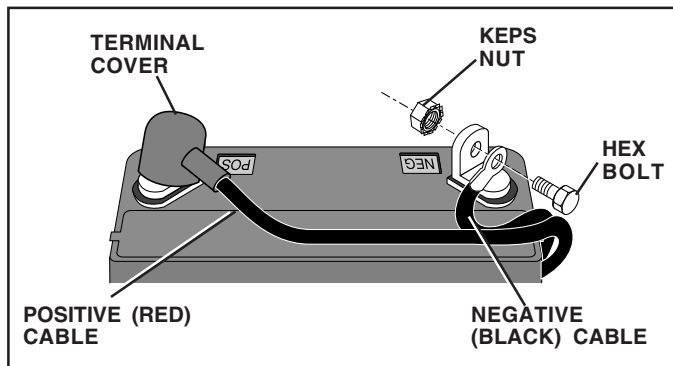

FIG. 28

## TO REPLACE HEADLIGHT BULB

- Raise hood.
- Pull bulb holder out of the hole in the backside of the grill.
- Replace bulb in holder and push bulb holder securely back into the hole in the backside of the grill.
- Close hood.

## INTERLOCKS AND RELAYS

Loose or damaged wiring may cause your tractor to run poorly, stop running, or prevent it from starting.

- Check wiring. See electrical wiring diagram in the Repair Parts section.

## TO REPLACE FUSE

Replace with 20 amp automotive-type plug-in fuse. The fuse holder is located behind the dash.

## TO REMOVE HOOD AND GRILL ASSEMBLY (See Fig. 29)

- Raise hood.
- Unsnap headlight wire connector.
- Stand in front of tractor. Grasp hood at sides, tilt toward engine and lift off of tractor.
- To replace, reverse above procedure.

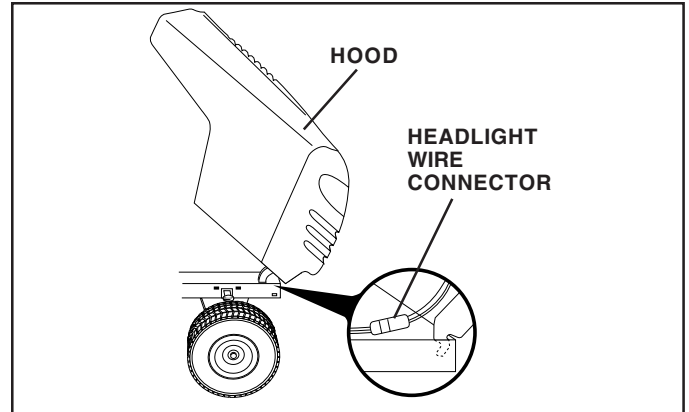

FIG. 29

## TO ADJUST THROTTLE CONTROL CABLE (See Fig. 30)

The throttle control has been preset at the factory and adjustment should not be necessary. Check adjustment as described below before loosening cable. If adjustment is necessary, proceed as follows:

- With engine not running, move throttle control lever from slow to choke position. Slowly move lever from choke to fast position.
- Check that holes "A" in governor control lever and hole in governor plate line-up. If holes "A" are not aligned, loosen clamp screw and move throttle cable until holes are aligned. Tighten clamp screw securely.

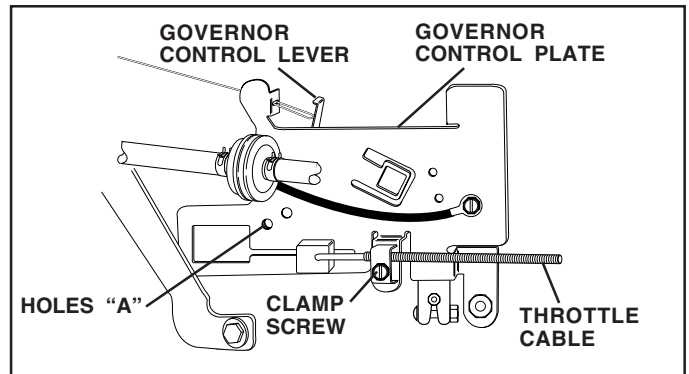

FIG. 30

## TO ADJUST CARBURETOR

The carburetor has been preset at the factory and adjustment should not be necessary. However, minor adjustment may be required to compensate for differences in fuel, temperature, altitude or load. If the carburetor does need adjustment, see engine manual.

High speed stop is factory adjusted. Do not adjust - damage may result.

**IMPORTANT:** NEVER TAMPER WITH THE ENGINE GOVERNOR, WHICH IS FACTORY SET FOR PROPER ENGINE SPEED. OVERSPEEDING THE ENGINE ABOVE THE FACTORY HIGH SPEED SETTING CAN BE DANGEROUS. IF YOU THINK THE ENGINE-GOVERNED HIGH SPEED NEEDS ADJUSTING, CONTACT YOUR NEAREST AUTHORIZED SERVICE CENTER/DEPARTMENT, WHICH HAS PROPER EQUIPMENT AND EXPERIENCE TO MAKE ANY NECESSARY ADJUSTMENTS.

---

# STORAGE

---

Immediately prepare your tractor for storage at the end of the season or if the tractor will not be used for 30 days or more.



**CAUTION: Never store the tractor with gasoline in the tank inside a building where fumes may reach an open flame or spark. Allow the engine to cool before storing in any enclosure.**

## TRACTOR

Remove mower from tractor for winter storage. When mower is to be stored for a period of time, clean it thoroughly, remove all dirt, grease, leaves, etc. Store in a clean, dry area.

- Clean entire tractor (See “CLEANING” in the Customer Responsibilities section of this manual).
- Inspect and replace belts, if necessary (See belt replacement instructions in the Service and Adjustments section of this manual).
- Lubricate as shown in the Customer Responsibilities section of this manual.
- Be sure that all nuts, bolts and screws are securely fastened. Inspect moving parts for damage, breakage and wear. Replace if necessary.
- Touch up all rusted or chipped paint surfaces; sand lightly before painting.

## BATTERY

- Fully charge the battery for storage.
- After a period of time in storage, battery may require recharging.
- To help prevent corrosion and power leakage during long periods of storage, battery cables should be disconnected and battery cleaned thoroughly (see “TO CLEAN BATTERY AND TERMINALS” in the Customer Responsibilities section of this manual).
- After cleaning, leave cables disconnected and place cables where they cannot come in contact with battery terminals.
- If battery is removed from tractor for storage, do not store battery directly on concrete or damp surfaces.

## ENGINE

### FUEL SYSTEM

**IMPORTANT:** IT IS IMPORTANT TO PREVENT GUM DEPOSITS FROM FORMING IN ESSENTIAL FUEL SYSTEM PARTS SUCH AS CARBURETOR, FUEL FILTER, FUEL HOSE, OR TANK DURING STORAGE. ALSO, EXPERIENCE INDICATES THAT ALCOHOL BLENDED FUELS (CALLED GASOHOL OR USING ETHANOL OR METHANOL) CAN ATTRACT MOISTURE WHICH LEADS TO SEPARATION AND FORMATION OF ACIDS DURING STORAGE. ACIDIC GAS CAN DAMAGE THE FUEL SYSTEM OF AN ENGINE WHILE IN STORAGE.

- Drain the fuel tank.
- Start the engine and let it run until the fuel lines and carburetor are empty.
- Never use engine or carburetor cleaner products in the fuel tank or permanent damage may occur.
- Use fresh fuel next season.

**NOTE:** Fuel stabilizer is an acceptable alternative in minimizing the formation of fuel gum deposits during storage. Add stabilizer to gasoline in fuel tank or storage container. Always follow the mix ratio found on stabilizer container. Run engine at least 10 minutes after adding stabilizer to allow the stabilizer to reach the carburetor. Do not drain the gas tank and carburetor if using fuel stabilizer.

### ENGINE OIL

Drain oil (with engine warm) and replace with clean engine oil. (See “ENGINE” in the Customer Responsibilities section of this manual).

### CYLINDER(S)

- Remove spark plug(s).
- Pour one ounce of oil through spark plug hole(s) into cylinder(s).
- Turn ignition key to “START” position for a few seconds to distribute oil.
- Replace with new spark plug(s).

### OTHER

- Do not store gasoline from one season to another.
- Replace your gasoline can if your can starts to rust. Rust and/or dirt in your gasoline will cause problems.
- If possible, store your tractor indoors and cover it to give protection from dust and dirt.
- Cover your tractor with a suitable protective cover that does not retain moisture. Do not use plastic. Plastic cannot breathe which allows condensation to form and will cause your tractor to rust.

**IMPORTANT:** NEVER COVER TRACTOR WHILE ENGINE AND EXHAUST AREAS ARE STILL WARM.



# TROUBLESHOOTING POINTS

PROBLEM	CAUSE	CORRECTION
<b>Will not start</b>	<ol style="list-style-type: none"> <li>1. Out of fuel.</li> <li>2. Engine not "CHOKED" properly.</li> <li>3. Engine flooded.</li> <li>4. Bad spark plug.</li> <li>5. Dirty air filter.</li> <li>6. Dirty fuel filter.</li> <li>7. Water in fuel.</li>   <li>8. Loose or damaged wiring.</li> <li>9. Carburetor out of adjustment.</li>   <li>10. Engine valves out of adjustment.</li> </ol>	<ol style="list-style-type: none"> <li>1. Fill fuel tank.</li> <li>2. See "TO START ENGINE" in Operation section.</li> <li>3. Wait several minutes before attempting to start.</li> <li>4. Replace spark plug.</li> <li>5. Clean/replace air filter.</li> <li>6. Replace fuel filter.</li> <li>7. Drain fuel tank and carburetor, refill tank with fresh gasoline and replace fuel filter.</li> <li>8. Check all wiring.</li> <li>9. See "To Adjust Carburetor" in Service Adjustments section.</li> <li>10. Contact an authorized service center/department.</li> </ol>
<b>Hard to start</b>	<ol style="list-style-type: none"> <li>1. Dirty air filter.</li> <li>2. Bad spark plug.</li> <li>3. Weak or dead battery.</li> <li>4. Dirty fuel filter.</li> <li>5. Stale or dirty fuel.</li> <li>6. Loose or damaged wiring.</li> <li>7. Carburetor out of adjustment.</li>   <li>8. Engine valves out of adjustment.</li> </ol>	<ol style="list-style-type: none"> <li>1. Clean/replace air filter.</li> <li>2. Replace spark plug.</li> <li>3. Recharge or replace battery.</li> <li>4. Replace fuel filter.</li> <li>5. Drain fuel tank and refill with fresh gasoline.</li> <li>6. Check all wiring.</li> <li>7. See "To Adjust Carburetor" in Service Adjustments section.</li> <li>8. Contact an authorized service center/department.</li> </ol>
<b>Engine will not turn over</b>	<ol style="list-style-type: none"> <li>1. Brake pedal not depressed.</li> <li>2. Attachment clutch is engaged.</li> <li>3. Weak or dead battery.</li> <li>4. Blown fuse.</li> <li>5. Corroded battery terminals.</li> <li>6. Loose or damaged wiring.</li> <li>7. Faulty ignition switch.</li> <li>8. Faulty solenoid or starter.</li> <li>9. Faulty operator presence switch(es).</li> </ol>	<ol style="list-style-type: none"> <li>1. Depress brake pedal.</li> <li>2. Disengage attachment clutch.</li> <li>3. Recharge or replace battery.</li> <li>4. Replace fuse.</li> <li>5. Clean battery terminals.</li> <li>6. Check all wiring.</li> <li>7. Check/replace ignition switch.</li> <li>8. Check/replace solenoid or starter.</li> <li>9. Contact an authorized service center/department.</li> </ol>
<b>Engine clicks but will not start</b>	<ol style="list-style-type: none"> <li>1. Weak or dead battery.</li> <li>2. Corroded battery terminals.</li> <li>3. Loose or damaged wiring.</li> <li>4. Faulty solenoid or starter.</li> </ol>	<ol style="list-style-type: none"> <li>1. Recharge or replace battery.</li> <li>2. Clean battery terminals.</li> <li>3. Check all wiring.</li> <li>4. Check/replace solenoid or starter.</li> </ol>
<b>Loss of power</b>	<ol style="list-style-type: none"> <li>1. Cutting too much grass/too fast.</li> <li>2. Throttle in "CHOKE" position.</li> <li>3. Build-up of grass, leaves and trash under mower.</li> <li>4. Dirty air filter.</li> <li>5. Low oil level/dirty oil.</li> <li>6. Faulty spark plug.</li> <li>7. Dirty fuel filter.</li> <li>8. Stale or dirty fuel.</li> <li>9. Water in fuel.</li>   <li>10. Spark plug wire loose.</li> <li>11. Dirty engine air screen/fins.</li> <li>12. Dirty/clogged muffler.</li> <li>13. Loose or damaged wiring.</li> <li>14. Carburetor out of adjustment.</li>   <li>15. Engine valves out of adjustment.</li> </ol>	<ol style="list-style-type: none"> <li>1. Set in "Higher Cut" position/reduce speed.</li> <li>2. Adjust throttle control.</li> <li>3. Clean underside of mower housing.</li> <li>4. Clean/replace air filter.</li> <li>5. Check oil level/change oil.</li> <li>6. Clean and regap or change spark plug.</li> <li>7. Replace fuel filter.</li> <li>8. Drain fuel tank and refill with fresh gasoline.</li> <li>9. Drain fuel tank and carburetor, refill tank with fresh gasoline and replace fuel filter.</li> <li>10. Connect and tighten spark plug wire.</li> <li>11. Clean engine air screen/fins.</li> <li>12. Clean/replace muffler.</li> <li>13. Check all wiring.</li> <li>14. See "To Adjust Carburetor" in Service Adjustments section.</li> <li>15. Contact an authorized service center/department.</li> </ol>
<b>Excessive vibration</b>	<ol style="list-style-type: none"> <li>1. Worn, bent or loose blade.</li> <li>2. Bent blade mandrel.</li> <li>3. Loose/damaged part(s).</li> </ol>	<ol style="list-style-type: none"> <li>1. Replace blade. Tighten blade bolt.</li> <li>2. Replace blade mandrel.</li> <li>3. Tighten loose part(s). Replace damaged parts.</li> </ol>

# TROUBLESHOOTING POINTS

PROBLEM	CAUSE	CORRECTION
Engine continues to run when operator leaves seat with attachment clutch engaged	<ol style="list-style-type: none"> <li>1. Faulty operator-safety presence control system.</li> </ol>	<ol style="list-style-type: none"> <li>1. Check wiring, switches and connections. If not corrected, contact an authorized service center/department.</li> </ol>
Poor cut - uneven	<ol style="list-style-type: none"> <li>1. Worn, bent or loose blade.</li> <li>2. Mower deck not level.</li> <li>3. Buildup of grass, leaves, and trash under mower.</li> <li>4. Bent blade mandrel.</li> <li>5. Clogged mower deck vent holes from buildup of grass, leaves, and trash around mandrels.</li> </ol>	<ol style="list-style-type: none"> <li>1. Replace blade. Tighten blade bolt.</li> <li>2. Level mower deck.</li> <li>3. Clean underside of mower housing.</li> <li>4. Replace blade mandrel.</li> <li>5. Clean around mandrels to open vent holes.</li> </ol>
Mower blades will not rotate	<ol style="list-style-type: none"> <li>1. Obstruction in clutch mechanism.</li> <li>2. Worn/damaged mower drive belt.</li> <li>3. Frozen idler pulley.</li> <li>4. Frozen blade mandrel.</li> </ol>	<ol style="list-style-type: none"> <li>1. Remove obstruction.</li> <li>2. Replace mower drive belt.</li> <li>3. Replace idler pulley.</li> <li>4. Replace blade mandrel.</li> </ol>
Poor grass discharge	<ol style="list-style-type: none"> <li>1. Engine speed too slow.</li> <li>2. Travel speed too fast.</li> <li>3. Wet grass.</li> <li>4. Mower deck not level.</li> <li>5. Low/uneven tire air pressure.</li> <li>6. Worn, bent or loose blade.</li> <li>7. Buildup of grass, leaves and trash under mower.</li> <li>8. Mower drive belt worn.</li> <li>9. Blades improperly installed.</li> <li>10. Improper blades used.</li> <li>11. Clogged mower deck vent holes from buildup of grass, leaves, and trash around mandrels.</li> </ol>	<ol style="list-style-type: none"> <li>1. Place throttle control in "FAST" position.</li> <li>2. Shift to slower speed.</li> <li>3. Allow grass to dry before mowing.</li> <li>4. Level mower deck.</li> <li>5. Check tires for proper air pressure.</li> <li>6. Replace/sharpen blade. Tighten blade bolt.</li> <li>7. Clean underside of mower housing.</li> <li>8. Replace mower drive belt.</li> <li>9. Reinstall blades sharp edge down.</li> <li>10. Replace with blades listed in this manual.</li> <li>11. Clean around mandrels to open vent holes.</li> </ol>
Headlight(s) not working (if so equipped)	<ol style="list-style-type: none"> <li>1. Switch is "OFF".</li> <li>2. Bulb(s) or lamp(s) burned out.</li> <li>3. Faulty light switch.</li> <li>4. Loose or damaged wiring.</li> <li>5. Blown fuse.</li> </ol>	<ol style="list-style-type: none"> <li>1. Turn switch "ON".</li> <li>2. Replace bulb(s) or lamp(s).</li> <li>3. Check/replace light switch.</li> <li>4. Check wiring and connections.</li> <li>5. Replace fuse.</li> </ol>
Battery will not charge	<ol style="list-style-type: none"> <li>1. Bad battery cell(s).</li> <li>2. Poor cable connections.</li> <li>3. Faulty regulator (if so equipped).</li> <li>4. Faulty alternator.</li> </ol>	<ol style="list-style-type: none"> <li>1. Replace battery.</li> <li>2. Check/clean all connections.</li> <li>3. Replace regulator.</li> <li>4. Replace alternator.</li> </ol>
Loss of drive	<ol style="list-style-type: none"> <li>1. Freewheel control in "disengaged" position.</li> <li>2. Motion drive belt worn, damaged, or broken.</li> <li>3. Air trapped in transmission during shipment or servicing.</li> </ol>	<ol style="list-style-type: none"> <li>1. Place freewheel control in "engaged" position.</li> <li>2. Replace motion drive belt.</li> <li>3. Purge transmission.</li> </ol>
Engine "backfires" when turning engine "OFF"	<ol style="list-style-type: none"> <li>1. Engine throttle control not set at "SLOW" position for 30 seconds before stopping engine.</li> </ol>	<ol style="list-style-type: none"> <li>1. Move throttle control to "SLOW" position and allow to idle for 30 seconds before stopping engine.</li> </ol>



# REPAIR PARTS

TRACTOR - MODEL NO. LT14A (JNA14H36A), PRODUCT NO. 954 13 00-84  
ELECTRICAL

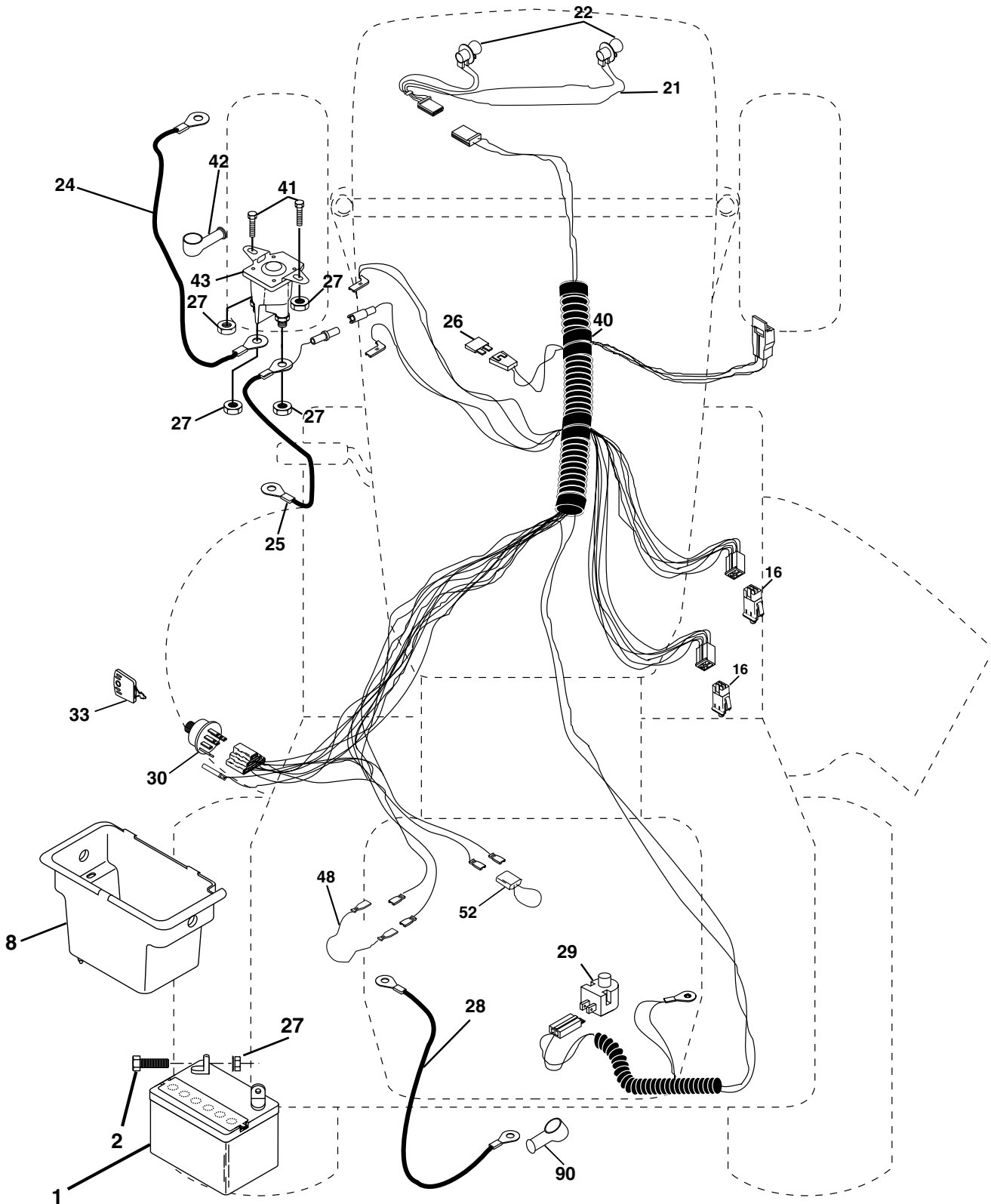

# REPAIR PARTS

TRACTOR - MODEL NO. LT14A (JNA14H36A), PRODUCT NO. 954 13 00-84  
ELECTRICAL

KEY NO.	PART NO.	DESCRIPTION
1	532 16 34-65	Battery 12 Volt 28 AMP
2	874 76 04-12	Bolt Hex Hd 1/4-20unc X 3/4
8	532 17 66-89	Battery Box
16	532 17 61-38	Switch Interlock Push-In
21	532 17 56-85	Harness Asm Light W/4152j
22	532 00 41-52	Bulb Light #1156
24	532 12 47-80	Cable Battery 6 Ga 11" red
25	532 14 61-47	Cable Battery 6 Ga 44" red w/16 wire
26	532 17 51-58	Fuse 20 AMP
27	873 51 04-00	Nut Keps Hex 1/4-20 Unc
28	532 12 47-73	Cable Ground 6 Ga 12" black
29	532 12 13-05	Switch Plunger Nc Gray
30	532 17 55-66	Switch Ign
33	532 14 04-01	Key Ign
40	532 17 97-20	Harness Ign.
41	871 11 04-08	Bolt Blk Fin Hex 1/4 - 20 x 1/2
42	532 13 15-63	Cover Terminal Red
43	532 17 88-61	Solenoid
48	532 14 08-44	Adapter Ammeter
52	532 14 19-40	Protection Wire Loop
90	532 18 04-49	Cover Terminal

**NOTE:** All component dimensions given in U.S. inches.  
1 inch = 25.4 mm.

# REPAIR PARTS

TRACTOR - MODEL NO. LT14A (JNA14H36A), PRODUCT NO. 954 13 00-84  
CHASSIS AND ENCLOSURES

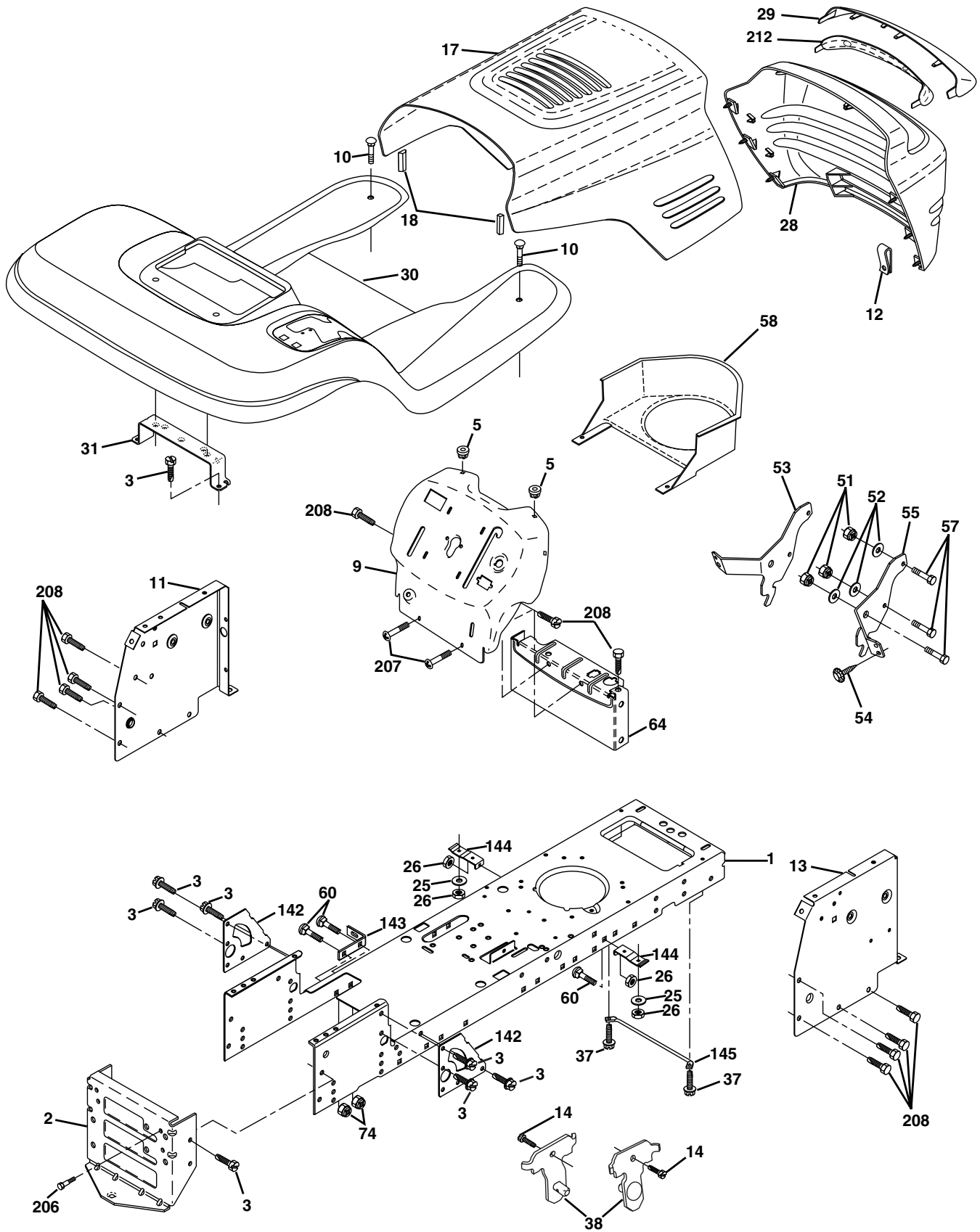

# REPAIR PARTS

## TRACTOR - MODEL NO. LT14A (JNA14H36A), PRODUCT NO. 954 13 00-84 CHASSIS AND ENCLOSURES

KEY NO.	PART NO.	DESCRIPTION
1	532 17 46-19	Chassis Stamping
2	532 17 65-54	Drawbar, 12 Ga.
3	817 06 06-12	Screw 3/8-16 x 3/4
5	532 15 52-72	Bumper Hood/Dash
9	532 17 21-51	Dash Slkscr
10	872 14 06-08	Bolt Carriage 3/8-16 x 1
11	532 17 49-96	Panel Dash Lh
12	532 14 56-60	Clip Tinnerman Grille P/L
13	532 18 17-19	Panel Dash Rh
14	817 49 06-08	Screw Thdrol 3/8-16 x 1/2
17	532 15 93-55	Hood LT/PL
18	532 12 69-38	Bumper Hood
24	874 78 06-16	Bolt Fin Hex 3/8-16unc x 1 Gr 5
25	819 13 13-12	Washer 13/32 X 13/16 X 12 Ga
26	873 80 06-00	Nut Lock Hex W/Ins 3/8-16 Unc
28	532 17 91-01	Grille/Lens Asm
29	532 16 81-54	Lens P/L
30	532 17 21-57	Fender Footrest LTST Pnt
31	532 13 99-76	Bracket Fender
37	817 49 05-08	Screw Thdrol 6/16-18 x 1/2 TYT
38	532 17 57-10	Bracket Asm Pivot Mower Rear
51	873 80 04-00	Nut Lock W/Insert 1/4-20unc
52	819 09 14-16	Washer 9/32 x 7/8 x 16 Ga.
53	532 14 46-97	Bracket Grille Lh
54	532 16 14-64	Screw Hex Wshd 8-18 x 7/8
55	532 14 46-96	Bracket Grille Rh
57	874 78 04-12	Bolt Hex 1/4-20 x 3/4
58	532 15 01-27	Air Duct Engine P/L
60	872 14 06-06	Bolt RdHd Sqnk 3/8-16 x 3/4
64	532 15 47-98	Dash Lower STLT
74	873 68 06-00	Nut Crownlock 3/8-16
142	532 17 57-02	Plate Reinforcement STLT
143	532 15 49-66	Bracket Swaybar Chassis
144	532 17 55-82	Bracket Footrest
145	532 15 65-24	Rod Pivot Chassis/Hood
206	532 17 01-65	Bolt Shoulder 5/16-18 TT
207	817 67 05-08	Screw Thdrol 5/16-18 x 1/2
208	817 67 06-08	Screw Thdrol 3/8-16x1/2 Ty-tt
212	532 15 62-29	Insert Lens Reflective
--	532 00 54-79	Plug Button

**NOTE:** All component dimensions given in U.S. inches  
1 inch = 25.4 mm





# REPAIR PARTS

## TRACTOR - MODEL NO. LT14A (JNA14H36A), PRODUCT NO. 954 13 00-84 DRIVE

KEY NO.	PART NO.	DESCRIPTION	KEY NO.	PART NO.	DESCRIPTION
1	-----	Transaxle Hydro Gr Model 322-0510 (Order parts from transaxle mfg.)	71	532 1691-83	Strap Torque Lh Hydro
8	532 1658-66	Rod Shift Fender	73	532 1691-82	Strap Torque Rh Hydro
10	876 02 04-16	Pin Cotter 1/8 x 1 CAD	74	532 1370-57	Spacer, Axle
14	810 04 04-00	Washer Lock Hvy Helical 1/4	75	532 12 17-49	Washer 25/32 x 1-1/4 x 16 Gauge
15	874 49 05-44	Bolt Hex Flg Hd 5/16-18 X Gr.5	76	812 00 00-01	E-Ring
16	873 80 05-00	Nut Lock Hex W/Ins. 5/16-18 Unc P	77	532 12 35-83	Key, Square
19	873 80 06-00	Nut Lock Hex W/Wsh 3/8-16 Unc	78	532 12 17-48	Washer 25/32 x 1-5/8 x 16 Gauge
21	532 12 12-74	Knob, Deluxe	81	532 1655-96	Shaft Asm. Cross Hydro
22	532 1694-98	Rod, Brake Hydro	82	532 1657-11	Spring Torsion
24	873 35 06-00	Nut	83	819 17 12-16	Washer 17/32 x 3/4 x 16 Ga.
25	532 1068-88	Spring, Brake Rod	84	532 1698-43	Link Transaxle
26	819 13 13-16	Washer	89	532 1666-02	Console, Shift
27	876 02 04-12	Pin Cotter 1/8 x 3/4 CAD.	90	532 1243-46	Nut Self-Thd 1/4
28	532 1757-65	Rod, Parking Brake	95	532 1702-01	Control Asm Bypass Hydro
29	532 07 16-73	Cap, Parking Brake	96	532 1247-88	Retainer Spring 1" Zinc/Cad
30	532 1749-73	Bracket, Transaxle	103	873 94 08-00	Nut Hex Jam Toplock 1/2-20 Unf
32	874 76 05-12	Bolt Hex Hd 5/16-18 Unc x 3/4	116	872 14 06-08	Boulon 3/8-16 x 1
34	532 1755-78	Shaft, Foot Pedal	120	873 90 06-00	Nut Lock Flg 3/8-16
35	532 1201-83	Bearing, Nylon	150	532 1754-56	Spacer Retainer
36	819 21 16-16	Washer	151	819 1332-10	Washer 13/32 x 2 x 10 Ga.
37	532 1249-63	Pin, Roll	156	532 1660-02	Washer Srrtd 5/16 ID x 1.0 x .125 Tk
38	532 1791-14	Pulley, Composite	158	532 1655-89	Bracket Shift Mount
39	874 76 06-48	Bolt	159	532 1654-94	Hub Tapered Flange Shift LT
41	532 1755-56	Keeper, Belt Idler	161	872 14 04-06	Bolt Rdhd Sqnk 1/4-20 x 3/4 Gr. 5
47	532 1277-83	Pulley, Idler, V-Groove	162	873 68 04-00	Nut Crownlock 1/4-20 Unc
48	532 1544-07	Bellcrank Clutch Grnd Drv Stl	163	874 78 04-16	Bolt Hex Fin 1/4-20 unc x 1 Gr. 5
49	532 1232-05	Retainer, Belt	164	819 09 10-10	Washer 5/8 x .281 x 10 Ga
50	874 76 06-24	Bolt	165	532 1656-23	Bracket Pivot Lever
51	873 68 06-00	Nut	166	532 1668-80	Screw 5/16-18 x 5/8 TT Yellow
52	873 68 05-00	Nut Crownlock 5/16-18	168	532 1654-92	Bolt Shoulder 5/16-18 x .561 TT
53	532 1057-10	Link, Clutch	169	532 1655-80	Plate Fastening Cross Shf. STLT/ CRD
55	532 1057-09	Spring, Return, Clutch	197	532 1696-13	Nyliner Snap-In 5/8" ID
56	817 06 06-20	Screw 3/8-16 x 1-1/4	198	532 1695-93	Washer Nyl. 7/8 ID x .105"
57	532 1402-94	V-Belt, Ground Drive	199	532 1696-12	Bolt Shoulder 5/16-18 Unc
59	532 1696-91	Keeper, Center Span	200	872 14 05-08	Bolt Rdhd Sq Neck 5/16-18unc x 1
61	817 12 06-14	Screw 3/8-16 x .875	202	872 11 06-14	Bolt Carr Sh 3/8-16 x 1-3/4 Gr. 5
62	532 1248-72	Cover, Pedal	205	819 17 16-16	Washer 17/32 x 1 x 16 Ga.
63	532 1754-10	Pulley, Clutch Eng	212	532 1452-12	Nut Hex Flg Lock
64	871 17 07-64	Bolt Hex 7/16-20 x 4 Ga. 5	250	817 06 06-12	Screw 3/8-16 x 3/4
65	810 04 07-00	Washer			
66	532 1547-78	Keeper Belt Engine			
70	532 1346-83	Guide Belt Mower Drive RH			

**NOTE:** All component dimensions give in U.S. inches.  
1 inch = 25.4 mm.

# REPAIR PARTS

TRACTOR - MODEL NO. LT14A (JNA14H36A), PRODUCT NO. 954 13 00-84  
STEERING ASSEMBLY

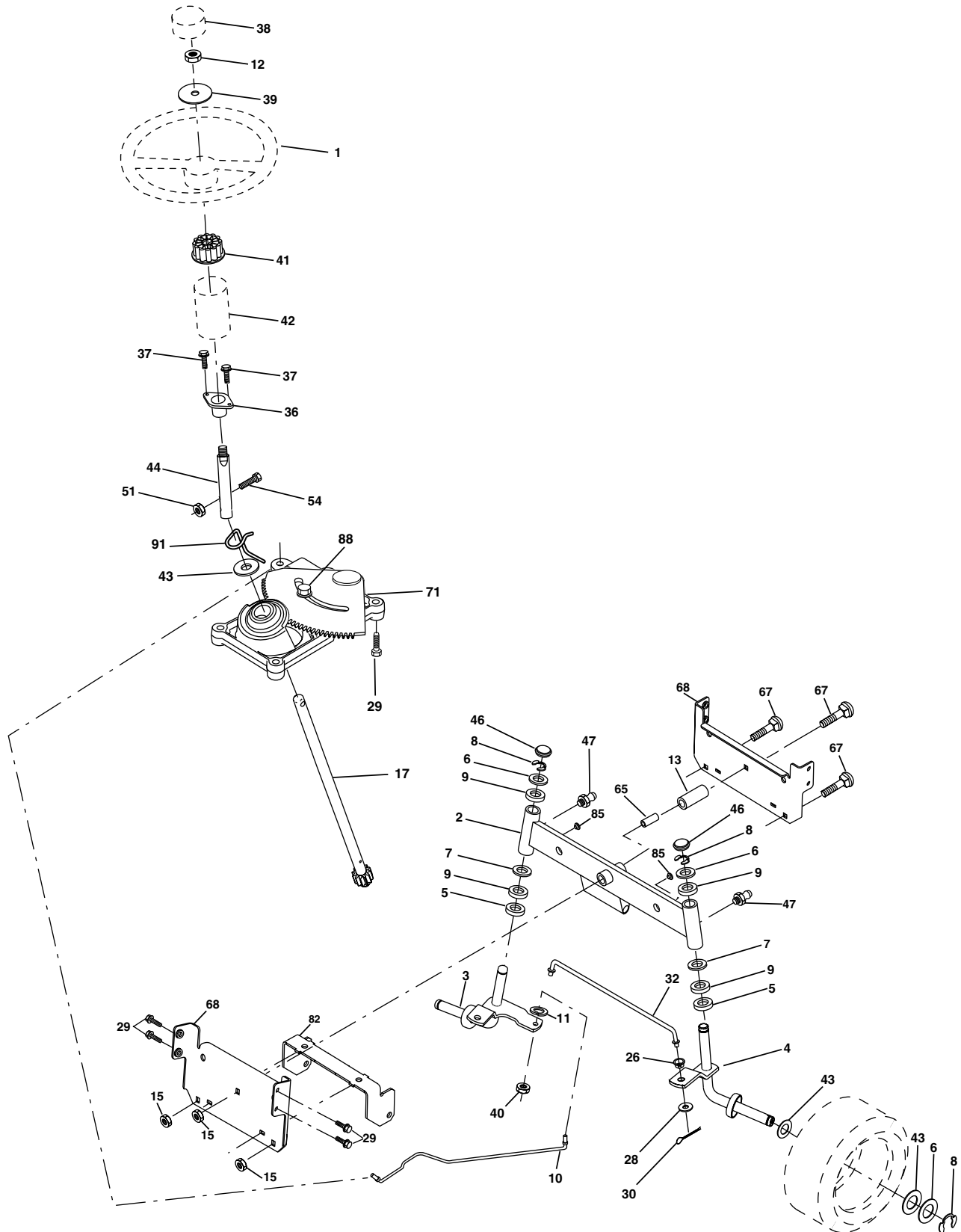

# REPAIR PARTS

## TRACTOR - MODEL NO. LT14A (JNA14H36A), PRODUCT NO. 954 13 00-84 STEERING ASSEMBLY

KEY NO.	PART NO.	DESCRIPTION
1	532 17 20-92	Wheel Steering
2	532 17 51-31	Axle Asm
3	532 16 98-40	Spindle Asm LH
4	532 16 98-39	Spindle Asm RH
5	532 12 49-31	Bearing Race Thrust Harden
6	532 12 17-48	Washer 25/32 X 1-5/8 X 16 Ga
7	819 27 20-16	Washer 27/32 X 1-1/4 X 16 Ga
8	812 00 00-29	Ring Klip #t5304-75
9	532 12 49-37	Bearing Col Strg Blk
10	532 17 51-21	Link Drag
11	810 04 06-00	Washer Lock Hvy Hlcl Spr 3/8
12	873 94 08-00	Nut Hex Jam Toplock 1/2-20 Unf
13	532 13 65-18	Spacer Brg Axle Front
15	532 14 52-12	Nut Hex Flange Lock
17	532 18 06-41	Shaft Asm Strg
26	532 12 68-47	Bushing Link Drag Blk LR
28	819 13 14-16	Washer 13/32 X 7/8 X 16 Ga
29	817 06 06-12	Screw 3/8-16x3/4
30	876 02 04-12	Pin Cotter 1/8 X 3/4 Cad
32	532 13 04-65	Rod Tie Wire Form 19 75 Mech
36	532 15 50-99	Bushing Strg
37	532 15 29-27	Screw
38	532 17 20-93	Cap Wheel Steering
39	819 18 24-11	Washer 9/16 x 1-1/2 x 11 Ga.
40	532 12 47-01	Lock nut
41	532 15 99-45	Adaptor Wheel Strg
42	532 16 96-33	Boot Steering Shaft
43	532 12 17-49	Washer 25/32 X 1 1/4 X 16 Ga
44	532 18 06-40	Extension Steering Shaft
46	532 12 12-32	Cap Spindle Fr Top Blk
47	532 12 48-36	Fitting Grease
51	873 54 04-00	Nut Crownlock 1/4-28
54	871 13 04-20	Bolt Hex 1/4-28 Unf x 1-1/4
65	532 16 03-67	Spacer Brace Axle
67	872 14 06-18	Bolt Rdhd Sq 3/8-16 x 2-1/4
68	532 16 98-27	Axle, Brace
71	532 17 51-46	Steering Asm
82	532 16 98-35	Bracket Susp Chassis Front
85	532 13 38-35	Fastner Christmas Tree
88	532 17 51-18	Bolt Shoulder 7/16-20
91	532 17 55-53	Clip Steering

**NOTE:** All component dimensions given in U.S. inches.  
1 inch = 25.4 mm.

# REPAIR PARTS

## TRACTOR - MODEL NO. LT14A (JNA14H36A), PRODUCT NO. 954 13 00-84 SEAT ASSEMBLY

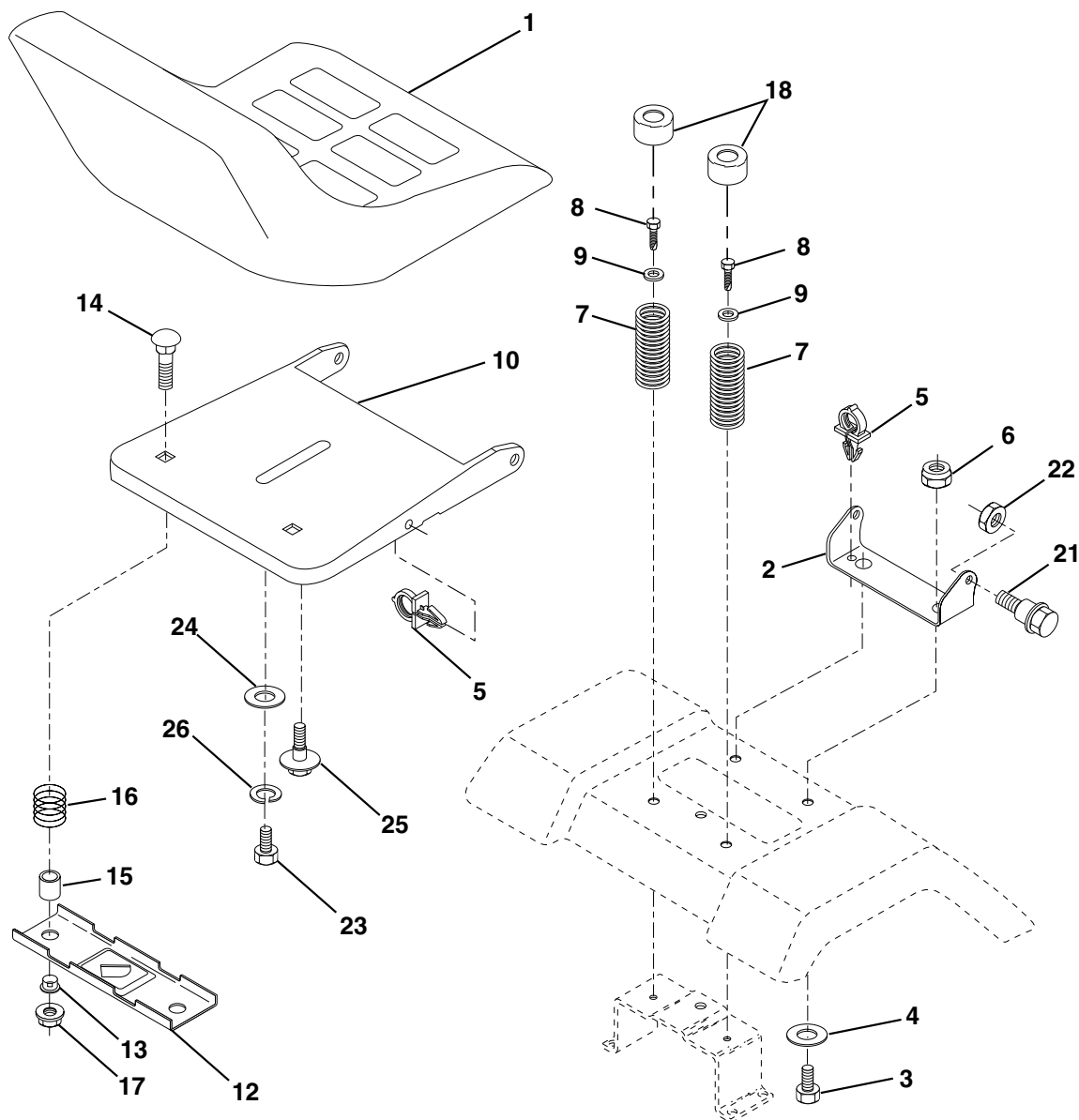

KEY NO.	PART NO.	DESCRIPTION
1	532 14 01-17	Seat
2	532 14 05-51	Bracket Pivot Seat 8 720
3	871 11 06-16	Bolt Fin Hex 3/8-16unc X 1
4	819 13 16-10	Washer 13/32 X 1 X 10 Ga
5	532 14 50-06	Clip Push-In
6	87380 06-00	Nut Hex w/Ins. 3/8-16 Unc
7	532 12 41-81	Spring Seat Cprsn 2 250 Blk Zi
8	817 00 06-16	Screw 3/8-16 X 1
9	819 13 16-14	Washer 13/32 X 1 X 14 Ga.
10	532 18 24-93	Pan Seat
12	532 12 12-46	Bracket Mounting Switch
13	532 12 12-48	Bushing Snap Blk Nyl 50 Id
14	872 05 04-12	Bolt Rdhd Sqnk 1/4-20x1-1/2

KEY NO.	PART NO.	DESCRIPTION
15	532 13 43-00	Spacer Split 28x 96 Yel Zinc
16	532 12 12-50	Spring Cprsn 1 27 Blk Pnt
17	532 12 39-76	Nut Lock 1/4 Lge Flg Gr 5 Zinc
18	532 12 42-38	Cap Spring Seat
21	532 17 18-52	Bolt Shoulder 5/16-18 Unc-2A
22	87380 05-00	Nut Hex Lock W/Ins 5/16-18
23	871 11 08-14	Bolt, Hex Black
24	819 17 19-12	Washer 17/32 X 1-3/16 X 12 Ga.
25	532 12 70-18	Bolt Shoulder 5/16-18 X 62
26	81004 08-00	WasherLock

**NOTE:** All component dimensions given in U.S. inches.  
1 inch = 25.4 mm

# REPAIR PARTS

TRACTOR - MODEL NO. LT14A (JNA14H36A), PRODUCT NO. 954 13 00-84  
DECALS

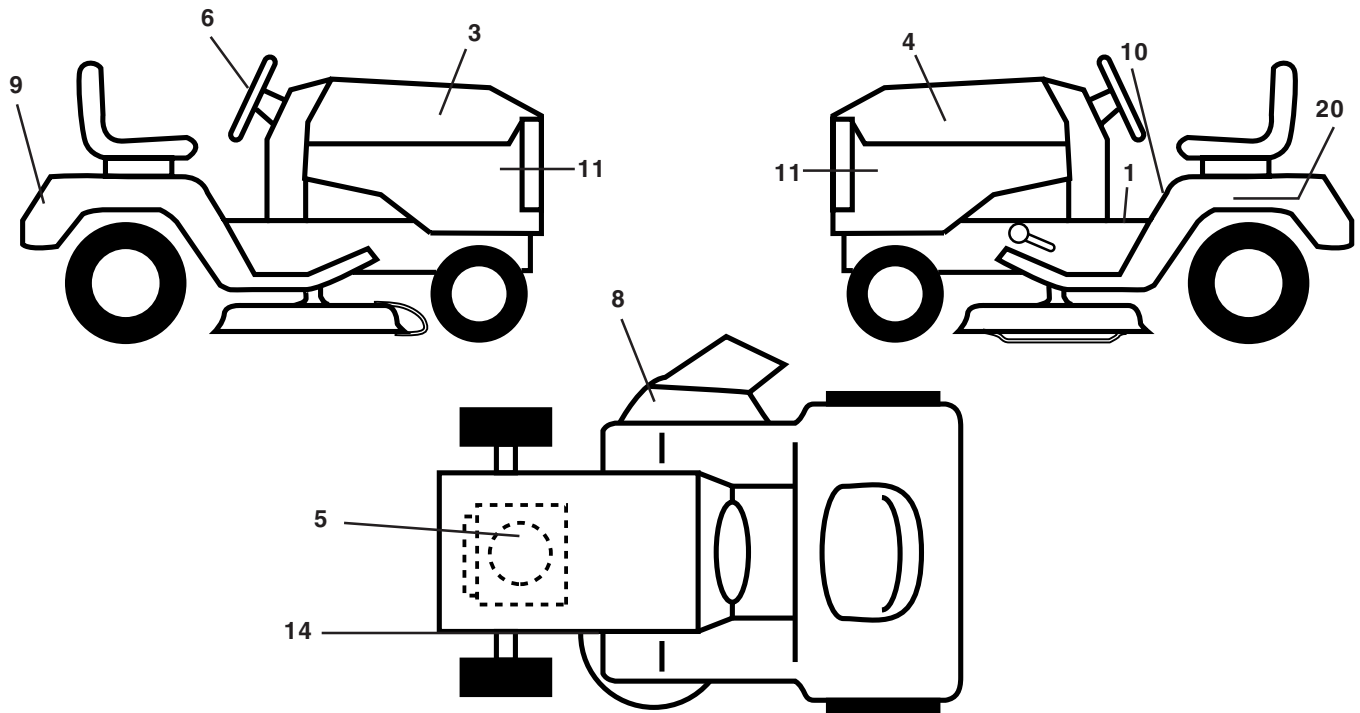

KEY NO.	PART NO.	DESCRIPTION
1	532 15 70-32	Decal Oper. Step Thru Eng/Fr
3	532 17 96-33	Decal Hood RH
4	532 17 96-34	Decal Hood LH
5	532 18 04-31	Decal Hood Cust.
6	532 17 05-65	Decal Wheel Steering
8	532 17 05-63	Decal Warning
9	532 14 17-61	Decal Fender
10	532 15 71-40	Decal Fender Danger Eng/Fr
11	532 16 29-27	Decal Hood Sidepanel

KEY NO.	PART NO.	DESCRIPTION
14	532 13 68-32	Decal V-Belt Schematic
20	532 14 50-05	Decal Bat Dan/Psn
--	532 13 83-11	Decal Handle Lft Height Adjust
--	532 16 92-10	Decal Bypass Lt Hydro
--	532 17 12-85	Pad Footrest RH
--	532 17 12-84	Pad Footrest LH
--	532 18 27-41	Manual Owner's (English)
--	532 18 27-42	Manual Owner's (French)

## WHEELS & TIRES

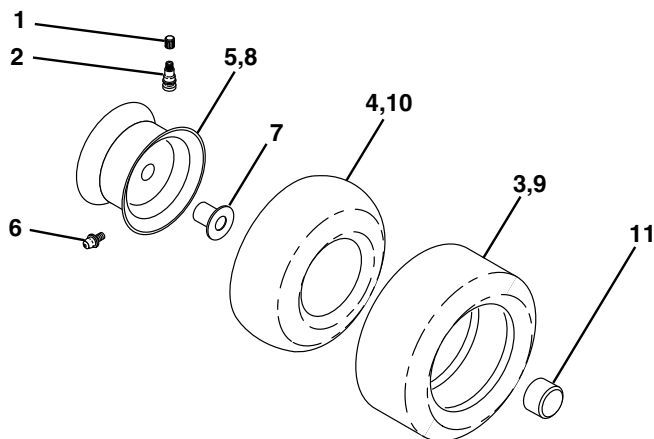

KEY NO.	PART NO.	DESCRIPTION
1	532 05 91-92	Cap Valve Tire
2	532 06 51-39	Stem Valve
3	532 10 62-22	Tire F Ts 15 X 6 0 - 6 Service
4	532 05 99-04	Tube Front (Service Item Only)
5	532 13 83-36	Rim Asm 6"front Silver Service
6	532 12 49-57	Fitting Grease (Front Wheel Only)
7	532 12 49-59	Bearing Flange (Front Wheel Only)
8	532 13 83-37	Rim Asm 8"rear Silver Service
9	532 12 46-35	Tire R Ts 18 x 8 5-8 C Service
10	532 12 49-26	Tube Rear (Service Item Only)
11	532 17 50-39	Cap Axle Blk 1 50 X 1 00
--	532 14 43-34	Sealant, Tire ( 10 oz. Tube)

**NOTE:** All component dimensions given in U.S. inches  
1 inch = 25.4 mm

# REPAIR PARTS

TRACTOR - MODEL NO. LT14A (JNA14H36A), PRODUCT NO. 954 13 00-84  
ENGINE

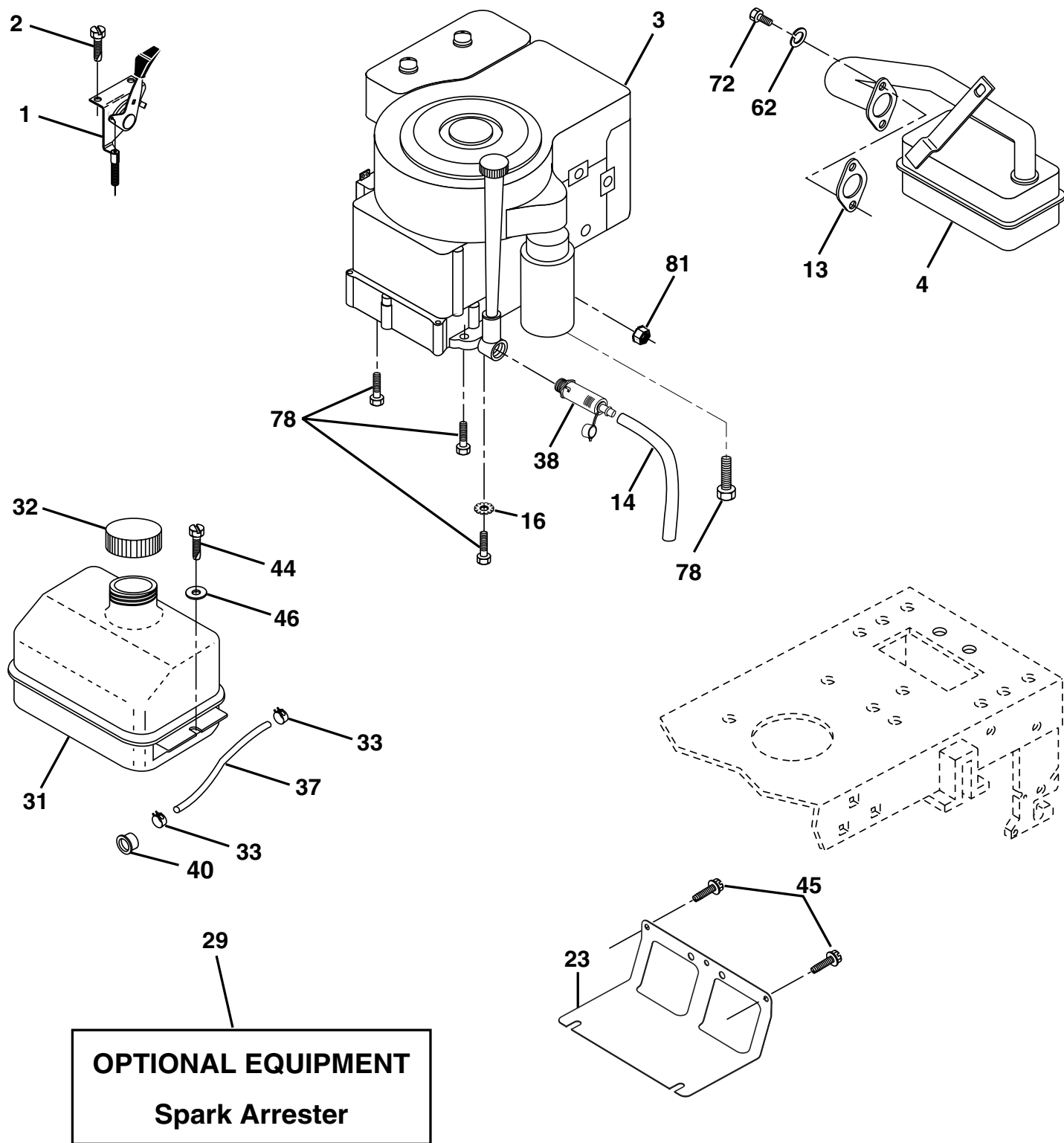

# REPAIR PARTS

TRACTOR - MODEL NO. LT14A (JNA14H36A), PRODUCT NO. 954 13 00-84  
ENGINE

KEY NO.	PART NO.	DESCRIPTION
1	532 17 05-51	Control Th/ch Flag
2	817 72 04-08	Screw Hex Thd Cut 1/4-20 x 1/2
3	-----	Engine, B&S 31G777 (Order parts from engine manufacturer)
4	532 13 73-52	Muffler
13	532 16 52-91	Gasket Eng
14	532 14 84-56	Tube Drain Oil Easy
16	811 05 06-00	Washer Lock Ext Tooth 3/8
23	532 16 98-37	Shield Brn/Dbr Guard
29	532 13 71-80	Kit Spark Arrestor (Flat Scrn)
31	532 10 92-02	Tank Fuel Front
32	532 14 05-27	Cap Asm Fuel W/sym Vented
33	532 12 34-87	Clamp Hose Black
37	532 13 70-40	Line Fuel 20"
38	532 14 83-15	Plug Drain Oil Easy
40	532 12 40-28	Bushing Snap Nyl Blk Fuel Line
44	817 67 04-12	Screw Hexwsh Thdrol 1/4-20 x 3/4
45	817 00 06-12	Screw Hexwsh Thdr 3/8-16 x 3/4
46	819 09 14-16	Washer 9/32 x 7/8 x 16 Ga
62	810 04 05-00	Washer lock 5/16
72	871 07 05-12	Screw Hex Hd Cap 5/16-18 x 3/4
78	817 06 06-20	Screw 3/8-16 x 1-1/4
81	873 51 04-00	Nut Keps Hex 1/4-20 Unc

**NOTE:** All component dimensions given in U.S. inches  
1 inch = 25.4 mm

# REPAIR PARTS

TRACTOR - MODEL NO. LT14A (JNA14H36A), PRODUCT NO. 954 13 00-84  
MOWER DECK

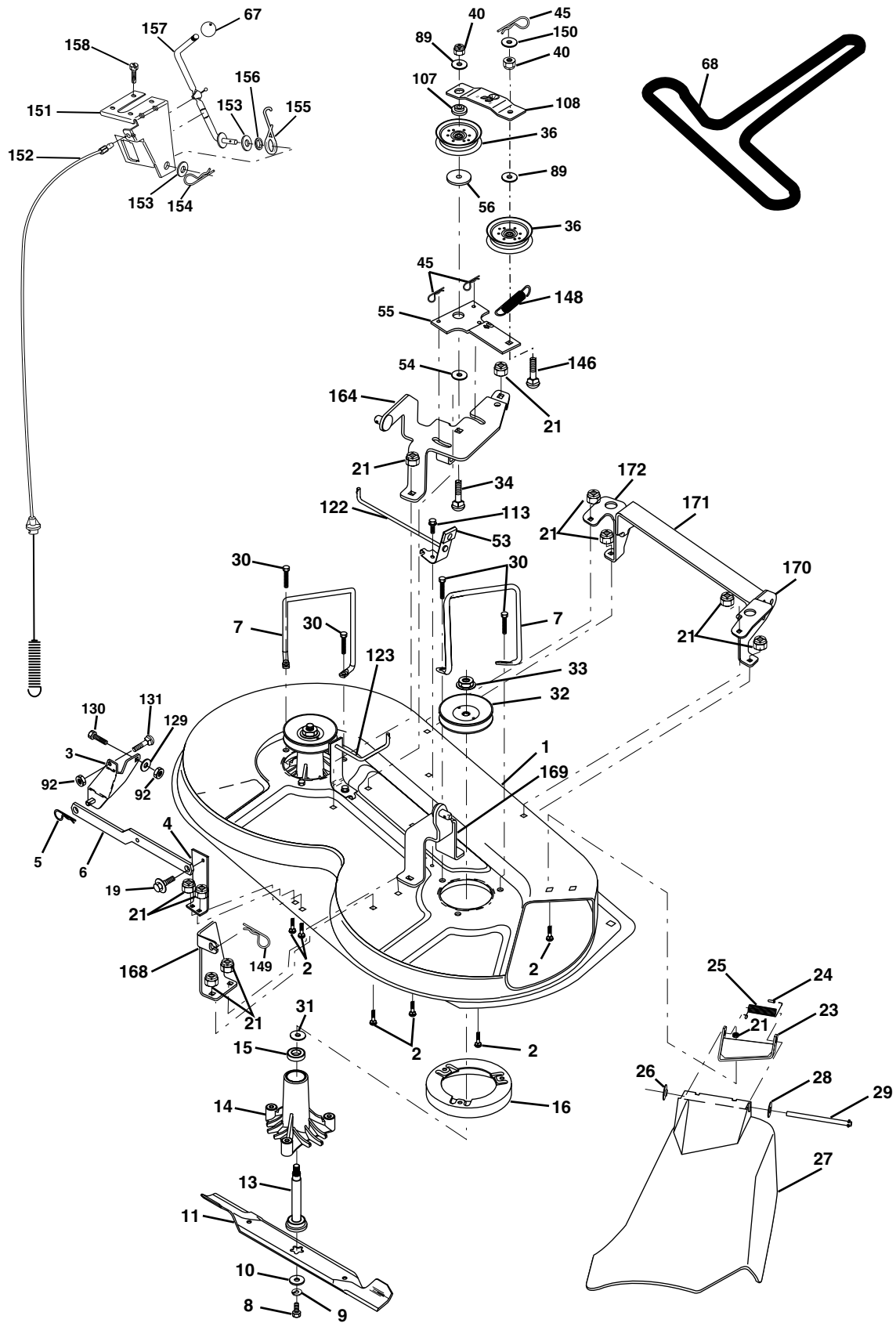



# REPAIR PARTS

## TRACTOR - MODEL NO. LT14A (JNA14H36A), PRODUCT NO. 954 13 00-84 MOWER DECK

KEY NO.	PART NO.	DESCRIPTION	KEY NO.	PART NO.	DESCRIPTION
1	532 17 45-95	Mower Deck Assembly	68	532 17 49-78	Belt
2	872 14 05-06	Bolt	69	876 02 03-12	Pin, Cotter 3/32 x 3/4
3	532 13 80-17	Bracket Assembly, Sway Bar	89	819 13 16-12	Washer 13/32 x 1 x 12 Ga
4	532 17 56-54	Bracket Sway Bar	92	873 80 06-00	Nut Lock Hex 3/8-16
5	532 12 46-70	Retainer Spring	107	532 13 35-02	Spacer, Retainer
6	532 17 80-24	Bar Sway Deck	108	532 13 35-03	Stiffener, Idler Arm
7	532 14 06-08	Keeper Belt	113	817 49 05-08	Screw Thdrol 5/16-18 x 1/2
8	532 85 08-57	Bolt, Hex 3/8-24 x 1.25 Gr. 8	122	532 17 45-05	Rod, Brake, LH
9	810 03 06-00	Washer, Lock Hvy Hlcl 3/8	123	532 17 45-04	Rod, Brake, RH
10	532 14 02-96	Washer, Hardened	129	819 13 13-12	Washer 13/32 x 13/16 x 12 Ga.
11	532 13 84-96	Blade, Mower	130	874 78 06-16	Bolt Fin Hex 3/8-16 x 1.0
13	532 13 76-45	Shaft Assembly, Mandrel, Vented	131	872 14 06-08	Bolt RDHD 3/8-16 x 1
14	532 12 87-74	Housing, Mandrel, Vented	146	532 16 58-91	Bolt Carriage Idler
15	532 11 04-85	Bearing, Ball, Mandrel	148	532 16 90-22	Spring Return Idler
16	532 17 44-93	Stripper, Mower Deck	149	532 16 58-98	Retainer Spring Yellow Zinc
19	532 13 28-27	Bolt, Shoulder	150	819 09 12-16	Washer 9/32 x 3/4 x 16 Ga.
21	873 68 05-00	Nut Crownlock 5/16-18	151	532 16 96-70	Bracket Clutch
23	532 13 66-31	Bracket, Mower Deflector	152	532 17 60-79	Cable Clutch
24	532 10 53-04	Cap, Sleeve	153	532 16 96-74	Washer Flat 3/8" Type B
25	532 12 37-13	Spring, Torsion, Deflector	154	532 16 96-75	Spring Retainer
26	532 11 04-52	Nut, Push	155	532 16 96-71	Spring Retention Lever
27	532 17 61-62	Shield, Deflector	156	532 16 96-72	Spacer
28	819 11 10-16	Washer 11/32 x 5/8 x 16 Ga.	157	532 16 96-69	Rod Clutch
29	532 12 19-80	Rod, Hinge	158	817 72 04-08	Screw Hex Thd Cut 1/4-20 x 1/2
30	532 17 39-84	Screw Thdrol Hex	164	532 17 49-76	Bracket Asm Idler Support
31	532 12 99-63	Washer, Spacer	168	532 17 23-77	Bracket Deck Cable
32	532 15 35-31	Pulley, Mandrel	169	532 17 49-77	Bracket Asm Suspension
33	532 17 83-42	Nut, Toplock, Flanged	170	532 17 23-59	Bracket Suspension RF
34	872 11 06-14	Bolt Rdhd 3/8-16 x 1-3/4	171	532 16 52-37	Brace Support Susp. Frt
36	532 13 14-94	Pulley, Idler, Flat	172	532 17 23-55	Bracket Suspension LF
40	873 68 06-00	Nut Crownlock 3/8-16	--	532 13 07-94	Mandrel Assembly (Includes Housing, Shaft and Shaft Hardware Only-Pulley Not Included)
45	532 12 47-88	Retainer, Spring	--	532 17 52-54	Replacement Mower, Complete
53	532 13 08-40	Brake Assembly			
54	532 13 39-43	Washer, Hardened			
55	532 13 38-40	Idler Arm Assembly			
56	532 16 57-23	Spacer, Retainer			
67	532 10 69-32	Knob RD 3/8-16 Plstc Thd			

**NOTE:** All component dimensions given in U.S. inches  
1 inch = 25.4 mm

# REPAIR PARTS

TRACTOR - MODEL NO. LT14A (JNA14H36A), PRODUCT NO. 954 13 00-84  
MOWER LIFT

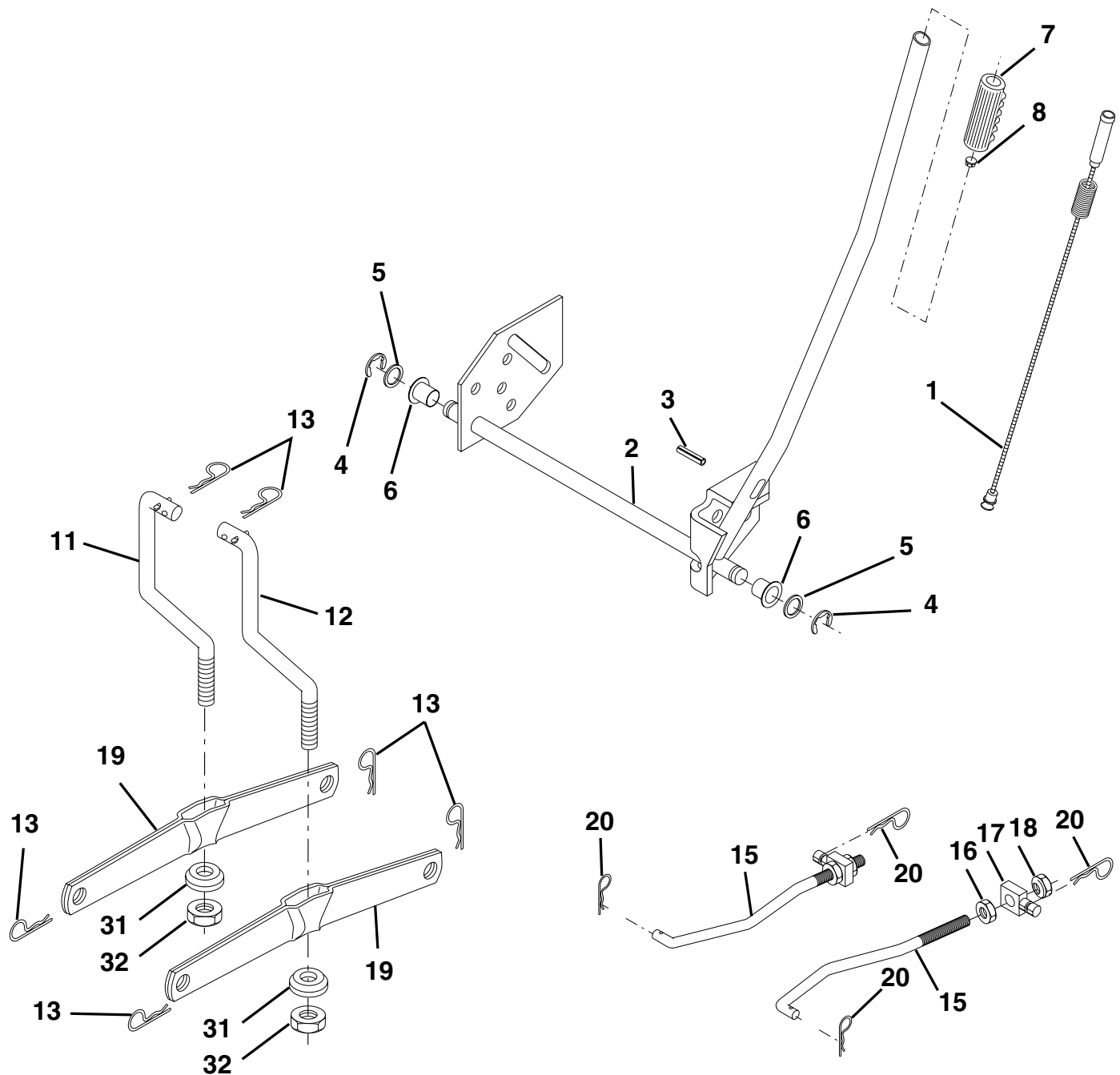

KEY NO.	PART NO.	DESCRIPTION
1	532 1594-60	Wire Asm Inner W/plunger LT
2	532 1594-71	Shaft Asm Lift
3	532 1057-67	Pin Groove
4	812 00 00-02	E Ring #5133-62
5	81921 16-21	Washer PLTD 21/32 X 1 X 21ga
6	532 1201-83	Bearing Nylon Blk 629 Id
7	532 1094-13	Grip Handle Bicycle
8	532 1223-65	Button Plunger Red
11	532 1398-65	Link Lift LH
12	532 1398-66	Link Lift RH
13	532 1246-70	Retainer Spring

KEY NO.	PART NO.	DESCRIPTION
15	532 1732-88	Link Front
16	873 35 08-00	Nut Jam Hex 1/2-13 Unc
17	532 1756-89	Trunnion
18	873 80 08-00	Nut Lock W/Wsh 1/2-13 Unc
19	532 1398-68	Arm Suspension Rear
20	532 1635-52	Spring, Retainer
31	532 1698-65	Bearing Pvt. Lift
32	873 54 06-00	Nut Crownlock 3/8-24

**NOTE:** All component dimensions given in U.S. inches  
1 inch = 25.4 mm

# SUGGESTED GUIDE FOR SIGHTING SLOPES FOR SAFE OPERATION

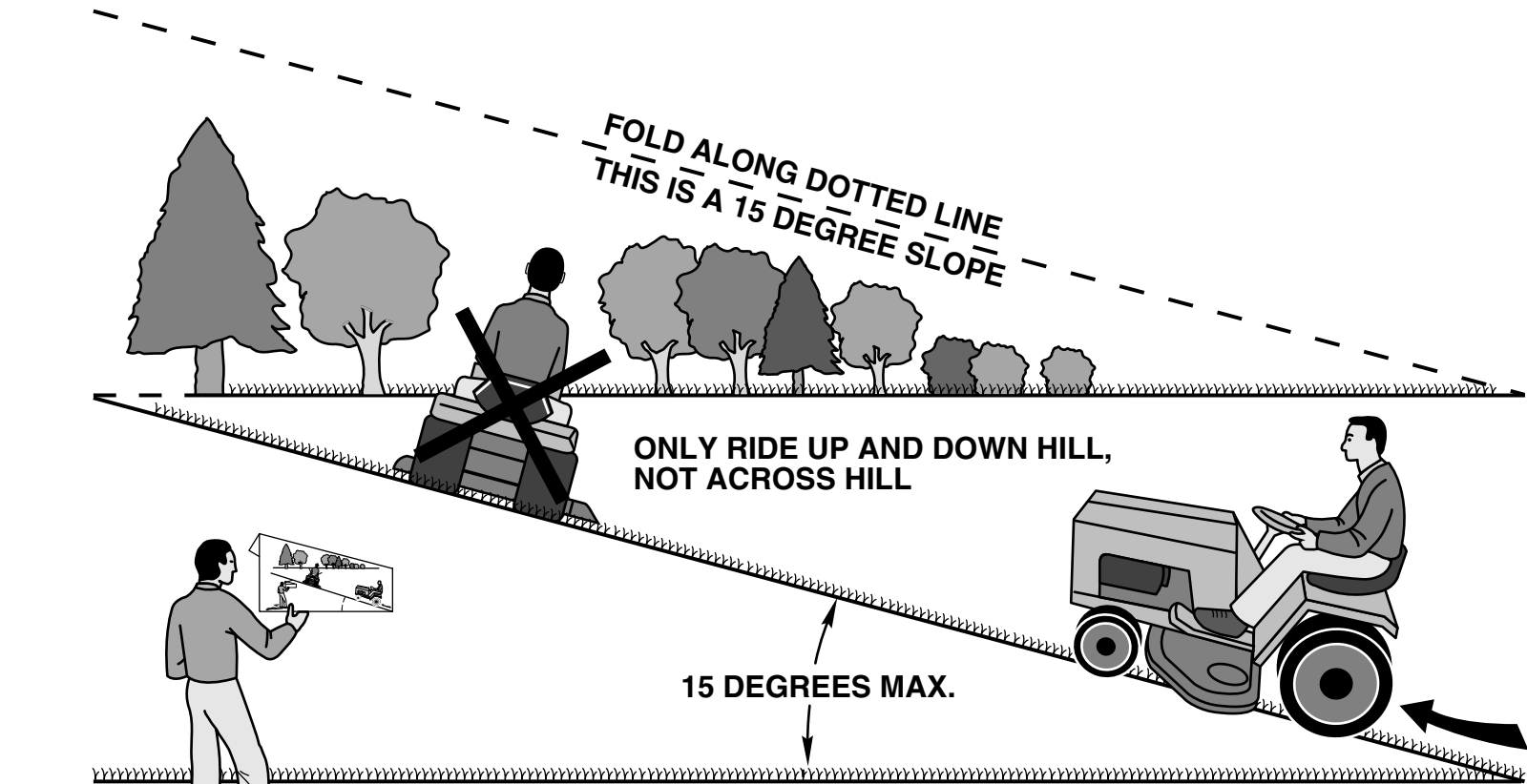

**WARNING:** To avoid serious injury, operate your tractor up and down the face of slopes, never across the face. Do not mow slopes greater than 15 degrees. Make turns gradually to prevent tipping or loss of control. Exercise extreme caution when changing direction on slopes.

1. Fold this page along dotted line indicated above.
2. Hold page before you so that its left edge is vertically parallel to a tree trunk or other upright structure.
3. Sight across the fold in the direction of hill slope you want to measure.
4. Compare the angle of the fold with the slope of the hill.

**Jonsered**