

OWNER'S MANUAL

Model No. CL36A

Product No. 954 12 00-93

36 Inch Mower

Grass Catcher

- **Assembly**
- **Operation**
- **Customer Responsibilities**
- **Repair Parts**



SAFETY RULES



Safe Operation Practices for Ride-On Mowers

IMPORTANT: THIS CUTTING MACHINE IS CAPABLE OF AMPUTATING HANDS AND FEET AND THROWING OBJECTS. FAILURE TO OBSERVE THE FOLLOWING SAFETY INSTRUCTIONS COULD RESULT IN SERIOUS INJURY OR DEATH.

I. GENERAL OPERATION

- Read, understand, and follow all instructions in the manual and on the machine before starting.
- Only allow responsible adults, who are familiar with the instructions, to operate the machine.
- Clear the area of objects such as rocks, toys, wire, etc., which could be picked up and thrown by the blade.
- Be sure the area is clear of other people before mowing. Stop machine if anyone enters the area.
- Never carry passengers.
- Do not mow in reverse unless absolutely necessary. Always look down and behind before and while backing.
- Be aware of the mower discharge direction and do not point it at anyone. Do not operate the mower without either the entire grass catcher or the guard in place.
- Slow down before turning.
- Never leave a running machine unattended. Always turn off blades, set parking brake, stop engine, and remove keys before dismounting.
- Turn off blades when not mowing.
- Stop engine before removing grass catcher or unclogging chute.
- Mow only in daylight or good artificial light.
- Do not operate the machine while under the influence of alcohol or drugs.
- Watch for traffic when operating near or crossing roadways.
- Use extra care when loading or unloading the machine into a trailer or truck.
- Data indicates that operators, age 60 years and above, are involved in a large percentage of riding mower-related injuries. These operators should evaluate their ability to operate the riding mower safely enough to protect themselves and others from serious injury.
- Keep machine free of grass, leaves or other debris build-up which can touch hot exhaust / engine parts and burn. Do not allow the mower deck to plow leaves or other debris which can cause build-up to occur. Clean any oil or fuel spillage before operating or storing the machine. Allow machine to cool before storage.

II. SLOPE OPERATION

Slopes are a major factor related to loss-of-control and tipover accidents, which can result in severe injury or death. All slopes require extra caution. If you cannot back up the slope or if you feel uneasy on it, do not mow it.

DO:

- Mow up and down slopes, not across.
- Remove obstacles such as rocks, tree limbs, etc.
- Watch for holes, ruts, or bumps. Uneven terrain could overturn the machine. *Tall grass can hide obstacles.*
- Use slow speed. Choose a low gear so that you will not have to stop or shift while on the slope.
- Follow the manufacturer's recommendations for wheel weights or counterweights to improve stability.
- Use extra care with grass catchers or other attachments. These can change the stability of the machine.
- Keep all movement on the slopes *slow* and *gradual*. Do not make sudden changes in speed or direction.
- Avoid starting or stopping on a slope. If tires lose traction, disengage the blades and proceed slowly *straight* down the slope.

DO NOT:

- *Do not* turn on slopes unless necessary, and then, turn slowly and gradually downhill, if possible.
- *Do not* mow near drop-offs, ditches, or embankments. The mower could suddenly turn over if a wheel is over the edge of a cliff or ditch, or if an edge caves in.
- *Do not* mow on wet grass. Reduced traction could cause sliding.
- *Do not* try to stabilize the machine by putting your foot on the ground.
- *Do not* use grass catcher on steep slopes.

III. CHILDREN

Tragic accidents can occur if the operator is not alert to the presence of children. Children are often attracted to the machine and the mowing activity. *Never* assume that children will remain where you last saw them.

- Keep children out of the mowing area and under the watchful care of another responsible adult.
- Be alert and turn machine off if children enter the area.
- Before and when backing, look behind and *down* for small children.
- Never carry children. They may fall off and be seriously injured or interfere with safe machine operation.
- Never allow children to operate the machine.
- Use extra care when approaching blind corners, shrubs, trees, or other objects that may obscure vision.

IV. SERVICE

- Use extra care in handling gasoline and other fuels. They are flammable and vapors are explosive.
 - Use only an approved container.
 - Never remove gas cap or add fuel with the engine running. Allow engine to cool before refueling. Do not smoke.
 - Never refuel the machine indoors.
 - Never store the machine or fuel container inside where there is an open flame, such as a water heater.
- Never run a machine inside a closed area.
- Keep nuts and bolts, especially blade attachment bolts, tight and keep equipment in good condition.
- Never tamper with safety devices. Check their proper operation regularly.
- Keep machine free of grass, leaves, or other debris build-up. Clean oil or fuel spillage. Allow machine to cool before storing.
- Stop and inspect the equipment if you strike an object. Repair, if necessary, before restarting.
- Never make adjustments or repairs with the engine running.
- Grass catcher components are subject to wear, damage, and deterioration, which could expose moving parts or allow objects to be thrown. Frequently check components and replace with manufacturer's recommended parts, when necessary.
- Mower blades are sharp and can cut. Wrap the blade(s) or wear gloves, and use extra caution when servicing them.
- Check brake operation frequently. Adjust and service as required.

SAFETY RULES

Safe Operation Practices for Ride-On Mowers

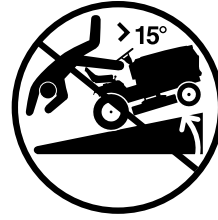

- Be sure the area is clear of other people before mowing. Stop machine if anyone enters the area.
- Never carry passengers or children even with the blades off.
- Do not mow in reverse unless absolutely necessary. Always look down and behind before and while backing.
- Never carry children. They may fall off and be seriously injured or interfere with safe machine operation.
- Keep children out of the mowing area and under the watchful care of another responsible adult.
- Be alert and turn machine off if children enter the area.
- Before and when backing, look behind and down for small children.
- Mow up and down slopes (15° Max), not across.
- Remove obstacles such as rocks, tree limbs, etc.
- Watch for holes, ruts, or bumps. Uneven terrain could overturn the machine. Tall grass can hide obstacles.
- Use slow speed. Choose a low gear so that you will not have to stop or shift while on the slope.
- Avoid starting or stopping on a slope. If tires lose traction, disengage the blades and proceed slowly straight down the slope.
- If machine stops while going uphill, disengage blades, shift into reverse and back down slowly.
- Do not turn on slopes unless necessary, and then, turn slowly and gradually downhill, if possible.

 **Look for this symbol to point out important safety precautions. It means CAUTION!!! BECOME ALERT!!! YOUR SAFETY IS INVOLVED.**

 **CAUTION: Do not coast down a hill in neutral, you may lose control of the tractor.**

 **CAUTION: Tow only the attachments that are recommended by and comply with specifications of the manufacturer of your tractor. Use common sense when towing. Operate only at the lowest possible speed when on a slope. Too heavy of a load, while on a slope, is dangerous. Tires can lose traction with the ground and cause you to lose control of your tractor.**

 **CAUTION: In order to prevent accidental starting when setting up, transporting, adjusting or making repairs, always disconnect spark plug wire and place wire where it cannot contact spark plug.**

CONGRATULATIONS on your purchase of a new Grass Catcher. It has been designed, engineered and manufactured to give you the best possible dependability and performance.

Should you experience any problems you cannot easily remedy, please contact your nearest authorized service center/department. They have competent, well trained technicians and the proper tools to service or repair this unit.

Please read and retain this manual. The instructions will enable you to assemble and maintain your Grass Catcher properly. Always observe the "SAFETY RULES".

NOTE: To make debris disposal easier 30 gallon plastic trash bags may be inserted in plastic grass containers. To order, see repair parts section of this manual.

TABLE OF CONTENTS

SAFETY RULES 2-3
 BAG OF PARTS 4-5
 ASSEMBLY 6-10
 OPERATION 11

CUSTOMER RESPONSIBILITIES 12
 STORAGE 12
 REPAIR PARTS.....center of manual

KNOW YOUR GRASS CATCHER

READ THIS OWNER'S MANUAL AND SAFETY RULES BEFORE ASSEMBLING OR OPERATING YOUR GRASS CATCHER. Compare the illustrations with the carton contents to familiarize yourself with the parts before starting the assembly. Study the operating instructions and safety precautions thoroughly to insure proper functioning of your Grass Catcher and to prevent injury to yourself and others. Save this manual for future reference.





The operation of any tractor can result in foreign objects thrown into the eyes, which can result in severe eye damage. Always wear safety glasses or eye shields before starting your tractor and while mowing. We recommend wide vision safety mask for over the spectacles or standard safety glasses.

UNPACKING INSTRUCTIONS





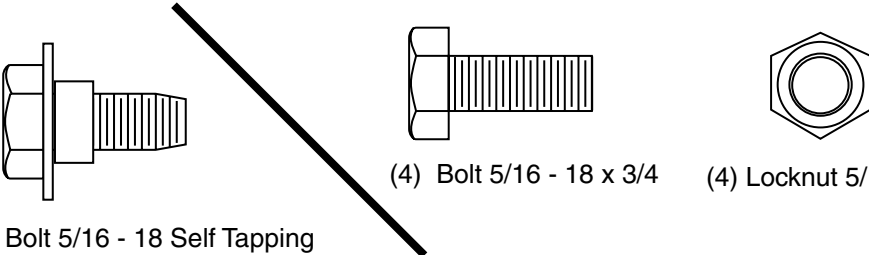

- Remove all parts and packing materials from carton.
- Fold flaps to inside of carton and turn carton upsidedown on floor of work area. To protect grass catcher cover during assembly place cover upsidedown on overturned carton.
- Check carton contents against list. Be sure all parts are there.

CARTON CONTENTS:

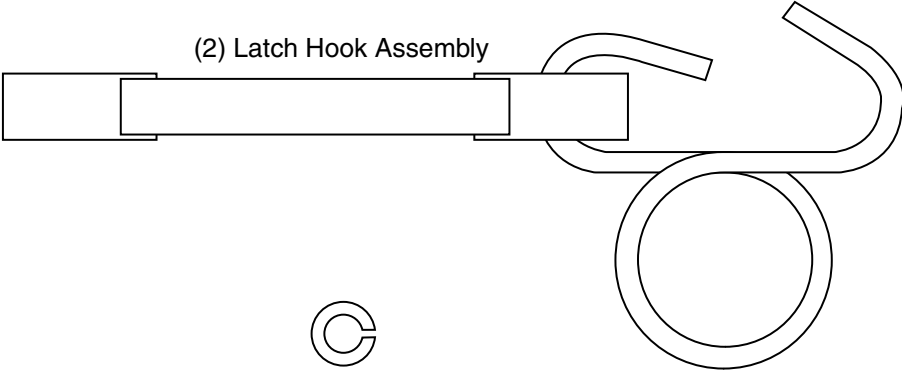
- | | |
|-----------------------|----------------------|
| (2) Container Tops | (1) Mounting Bracket |
| (2) Container Bottoms | (1) Cover Assembly |
| (1) Upper Chute | (1) Cover Seal |
| (1) Lower Chute | (1) Bag of Parts |
| (1) Support Post | (1) Owner's Manual |

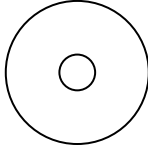
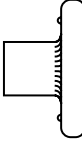
BAG OF PARTS CONTENTS	
ASSEMBLY LOCATION	HARDWARE SHOWN ACTUAL SIZE
REAR MOUNTING BRACKET TO DRAW BAR	GROUP "A"  (4) Shoulder Bolt 5/16 - 18 Self Tapping (4) Bolt 5/16 - 18 x 3/4 (4) Locknut 5/16-18
SUPPORT POST TO CONTAINER SUPPORT	GROUP "B"  (3) Carriage Bolt 5/16 - 18 x 3/4 (3) Locknut 5/16-18
SUPPORT POST TO MOUNTING BRACKET	GROUP "C" (1) Bracket Support Pin  (1) Retainer Spring (3) Tubing End Caps

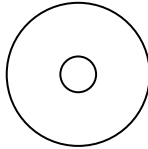
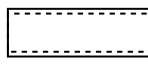
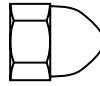
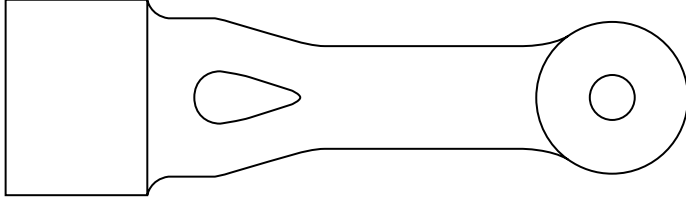
BAG OF PARTS CONTENTS (continued)

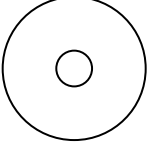
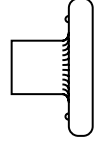
<p>LOWER CHUTE ASSEMBLY TO MOWER DECK</p>	<p>GROUP "D"</p>	<div style="text-align: center;">  <p>(2) Latch Hook Assembly</p> </div> <div style="display: flex; justify-content: space-around; margin-top: 20px;"> <div style="text-align: center;">  <p>(2) Screw #10 x 5/8</p> </div> <div style="text-align: center;">  <p>(2) Washer, Lock #10</p> </div> </div> <div style="display: flex; justify-content: space-around; margin-top: 20px;"> <div style="text-align: center;">  <p>(2) Washer 3/16 x 3/4 x 16 Ga.</p> </div> <div style="text-align: center;">  <p>(2) Nut, Weld #10</p> </div> </div>
<p>CHUTE LATCH ASSEMBLY TO UPPER CHUTE</p>	<p>GROUP "E"</p>	<div style="display: flex; justify-content: space-around; margin-bottom: 10px;"> <div style="text-align: center;">  <p>(1) Screw #10 x 1-1/8</p> </div> <div style="text-align: center;">  <p>(2) Washer 3/16 x 3/4 x 16 Ga.</p> </div> <div style="text-align: center;">  <p>(1) Spacer, Split #10</p> </div> <div style="text-align: center;">  <p>(1) Nut, Acorn #10</p> </div> </div>
<p>CHUTE LATCH ASSEMBLY TO LOWER CHUTE</p>	<p>GROUP "F "</p>	<div style="display: flex; justify-content: space-between; margin-bottom: 20px;"> <div style="text-align: center;">  <p>(1) Rubber Latch</p> </div> </div> <div style="display: flex; justify-content: space-around;"> <div style="text-align: center;">  <p>(1) Screw #10 x 5/8</p> </div> <div style="text-align: center;">  <p>(1) Washer, Lock #10</p> </div> <div style="text-align: center;">  <p>(1) Washer 3/16 x 3/4 x 16 Ga.</p> </div> <div style="text-align: center;">  <p>(1) Nut, Weld #10</p> </div> </div>

ASSEMBLY

PARTS IDENTIFICATION

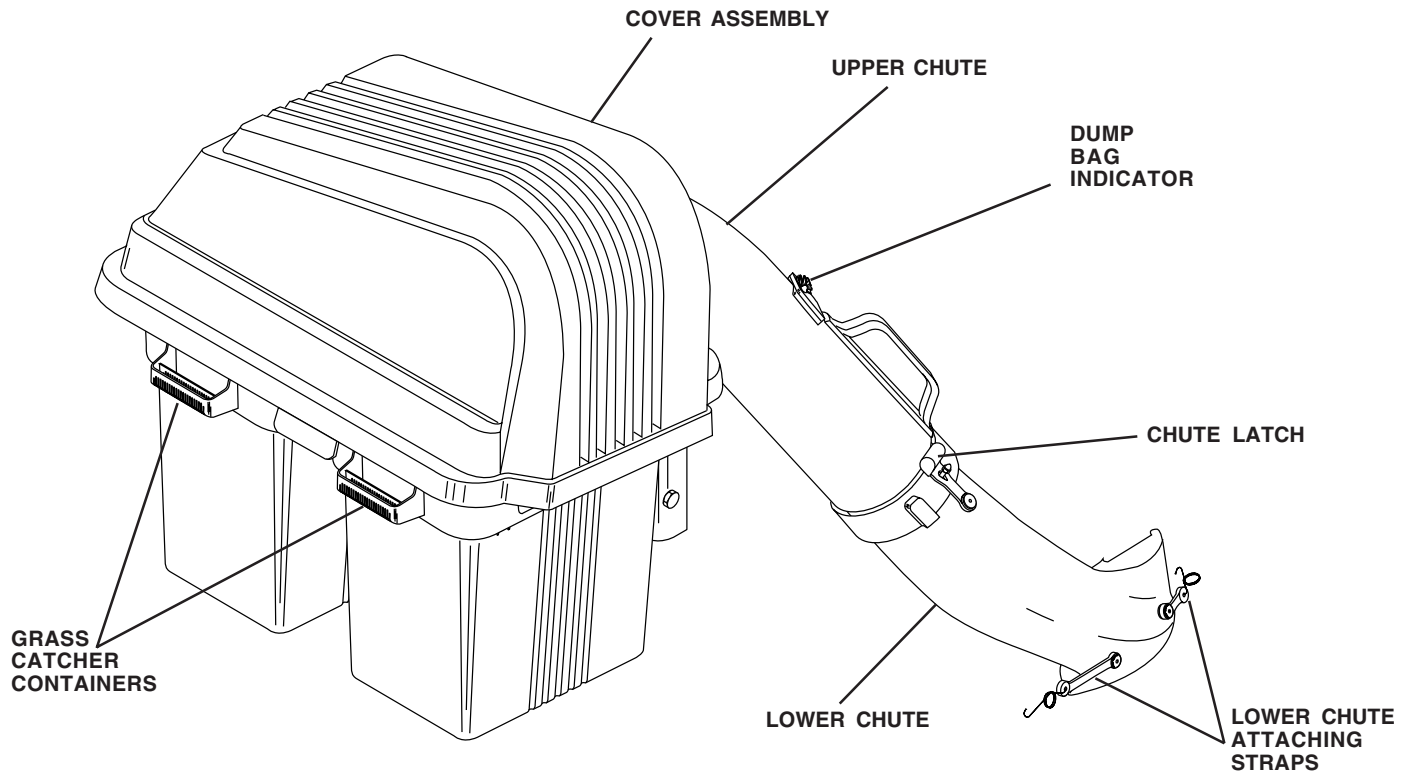

NOTE: When right hand (R.H.) and left hand (L.H.) are mentioned in this manual, it means when you are seated on the tractor, in the operator's position.

THESE ARE THE TOOLS YOU WILL NEED TO ASSEMBLE YOUR GRASS CATCHER:

- | | |
|----------------------------|----------------------------|
| (1) 3/8" Wrench | (1) Drive Ratchet |
| (1) 1/2" Wrench | (1) 3" or longer Extension |
| (2) 9/16" Wrenches | (1) Short Handle |
| (1) 1/2" Socket | Phillips Screwdriver |
| (1) 9/16" Deep well Socket | |

CAUTION: BEFORE ASSEMBLING GRASS CATCHER TO TRACTOR:

- Depress clutch/brake pedal fully and set parking brake.
- Place gearshift/motion control lever in neutral (N) position.
- Place attachment clutch in "DISENGAGED" position.
- Turn ignition key "OFF" and remove key.
- Make sure the blade and all moving parts have completely stopped.
- Disconnect spark plug wire from spark plug and place wire where it cannot come in contact with plug.



ASSEMBLY

1 REAR MOUNTING BRACKET (See Figs. 1A, 1B & 1C)

NOTE: If your tractor already has four (4) shoulder bolts installed on the rear drawbar, simply hang the mounting bracket, lanced tabs towards bottom, on the bolts. Discard hardware group "A" and disregard the remaining Step 1 instructions.

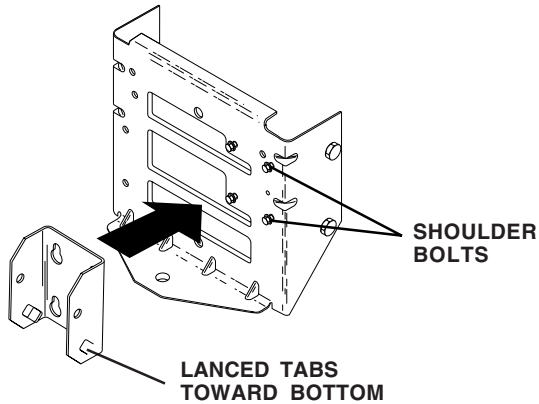

FIG. 1A

If your tractor does not have four (4) shoulder bolts installed on the drawbar, follow the instructions below.

Use Hardware - - GROUP "A"

Only one set of hardware in GROUP "A" will be used to mount the rear mounting bracket. To determine which set is correct for your tractor, check to see if there are (2) two upper corner ribs on each side of drawbar. If your tractor has the upper corner ribs, use the (4) four self tapping shoulder bolts. If your tractor does not have the corner ribs, use the set of (4) four bolts and locknuts.

SELF TAPPING SHOULDER BOLTS (See Fig. 1B)

- Using the four formed holes in the drawbar, install the four shoulder bolts as shown and tighten securely.
- Hang the mounting bracket, lanced tabs towards bottom, on the bolts.

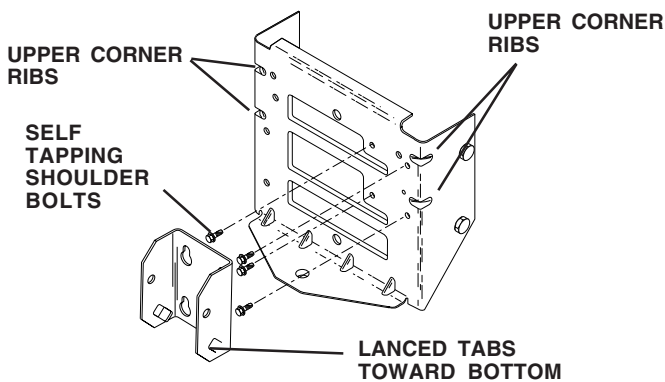

FIG. 1B

BOLTS AND LOCKNUTS (See Fig. 1C)

- Assemble the mounting bracket, lanced tabs towards bottom, using the four smaller inside holes on the drawbar.
- Install the four bolts and locknuts as shown and tighten securely.

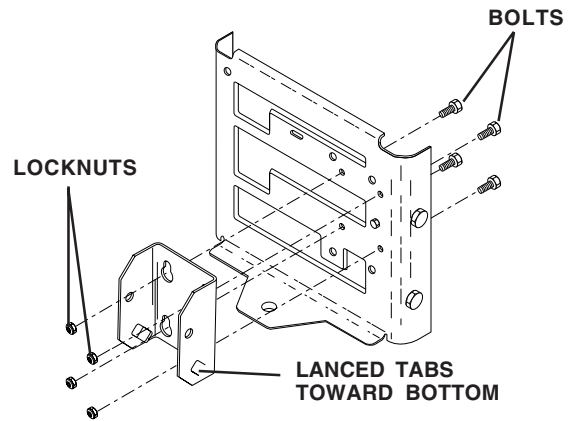

FIG. 1C

2 COVER SEAL (See Fig. 2) No hardware required

- Align mark on seal with mark at cover opening.
- Work seal into opening so cover sits between flanges of seal.

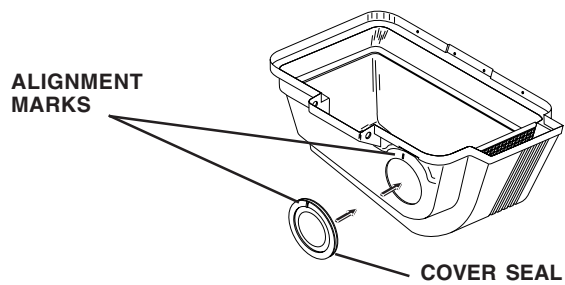

FIG. 2

3 SUPPORT POST (See Fig. 3) Use Hardware - - GROUP "B"



CAUTION: Container support is spring loaded and locked to the cover. Handle cover assembly carefully so as not to unlatch the cover from the container support.

- Rotate cover assembly onto its side as shown.
- Assemble support post to container support with the three (3) carriage bolts and locknuts. Tighten securely.

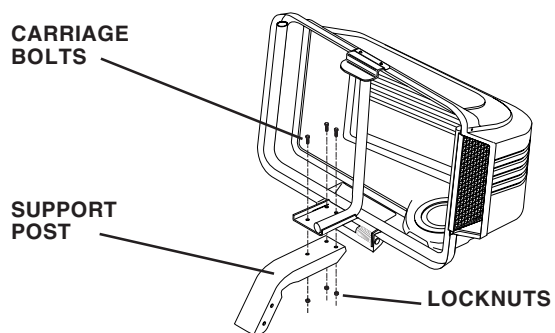

FIG. 3

ASSEMBLY

4 MOUNTING COVER ASSEMBLY TO TRACTOR (See Fig. 4)

Use Hardware - - GROUP "C"

NOTE: For ease of assembly, you may wish to obtain the assistance of another person for mounting assembly to tractor.

- Raise seat on tractor to allow assembly to be mounted.
- With cover closed, lift assembly and place support post inside mounting bracket. Allow assembly to rest on lanced tabs of mounting bracket.
- Line up holes in mounting bracket with holes in support post and insert bracket support pin. Secure with retainer spring.
- Unlatch and open cover.
- Install the three (3) tubing end caps onto container support.
- Tap each end cap onto container support tubes to seat securely.

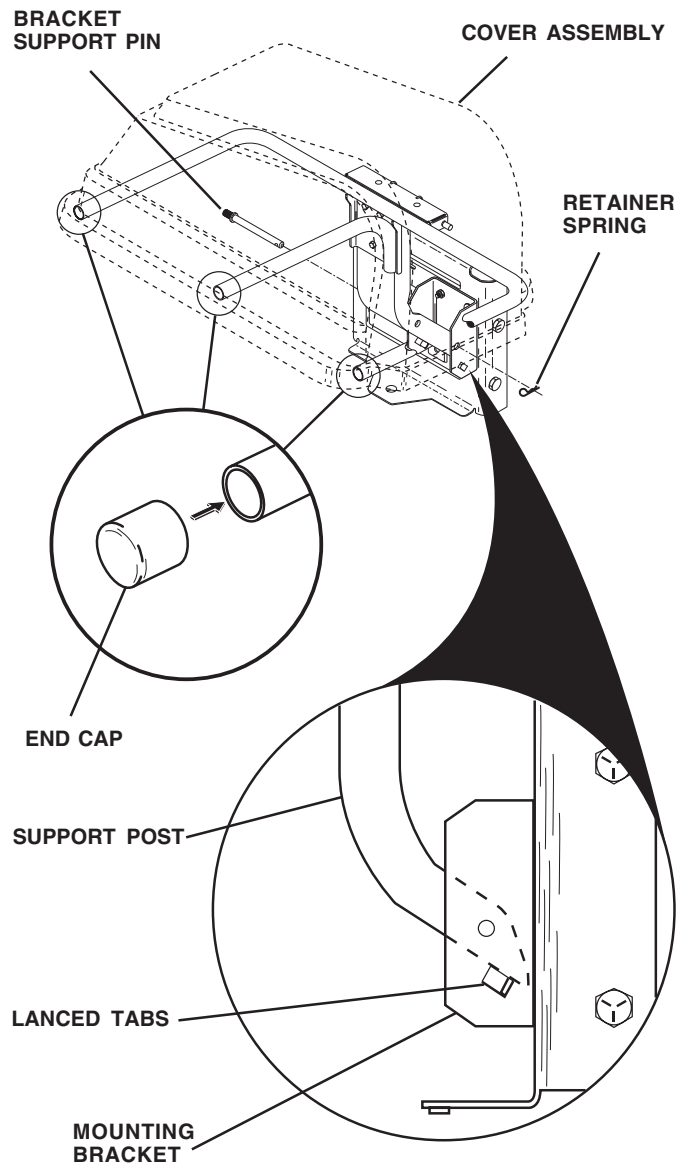

FIG. 4

5 CONTAINER ASSEMBLY (See Fig. 5)

No hardware required

- Place bottom half inside of top half, as shown.
- Place one foot inside bottom half and lift top half to meet bottom half.
- Press halves tightly together while lifting top to lock into place as shown.

IMPORTANT: BEFORE LOCKING THE TABS, HOOKED EDGES ON BOTH HALVES MUST OVERLAP TO FORM SEAL AS SHOWN IN INSET.

- Repeat for second container.

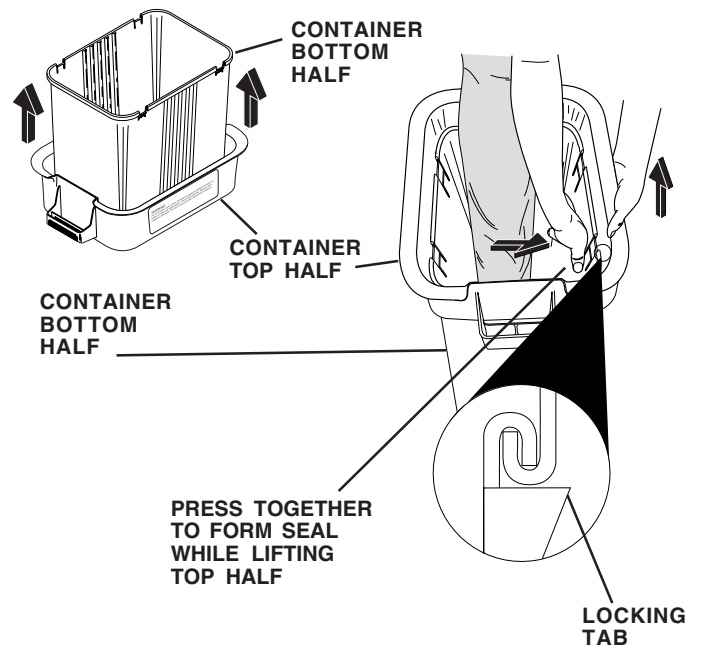

ASSEMBLY CHECK: Squeeze sides of lower half of container and check that there is no gap between upper and lower halves. If a gap appears, unlock tabs to separate container halves and repeat instructions above.

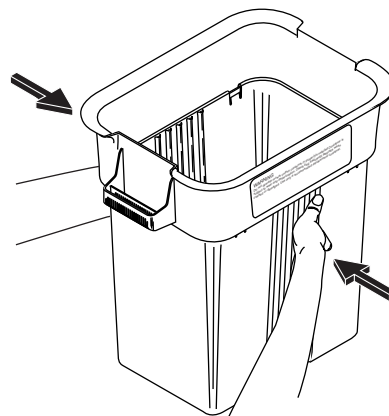

FIG. 5

ASSEMBLY

6 CONTAINER MOUNTING (See Fig. 6) No hardware required

- Install one container to left side first with warning to outside of unit. Install other container to right side.

NOTE: Right container should always overlap left container at center support.

- Close cover and lock latch handle over center support tube.

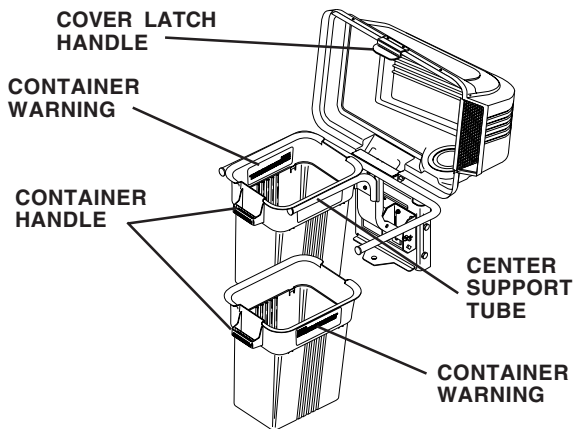

FIG. 6

7 LOWER CHUTE (See Figs. 7A & 7B) Use Hardware - - GROUP "D"

- Press weld nut into rubber latch and install two latch hook assemblies to lower chute using screw, flat washer, and lock washer as shown.
- Tighten hardware securely.
- Raise and hold deflector shield in upright position.
- Place front of chute over front of mower deck opening and slide into place as shown.
- Hook front latch down into latch hole at front of mower deck.
- Hook rear latch down into latch hole at back of mower deck.



CAUTION: Do not remove discharge guard from mower. Raise and hold guard when attaching lower chute and allow it to rest on chute while in operation.

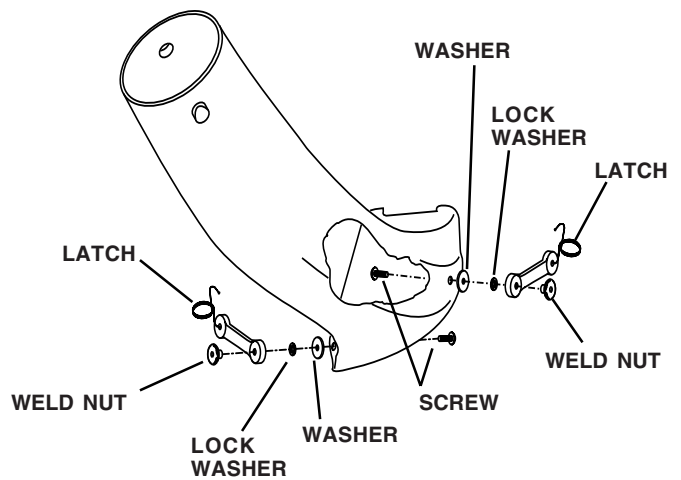

FIG. 7A

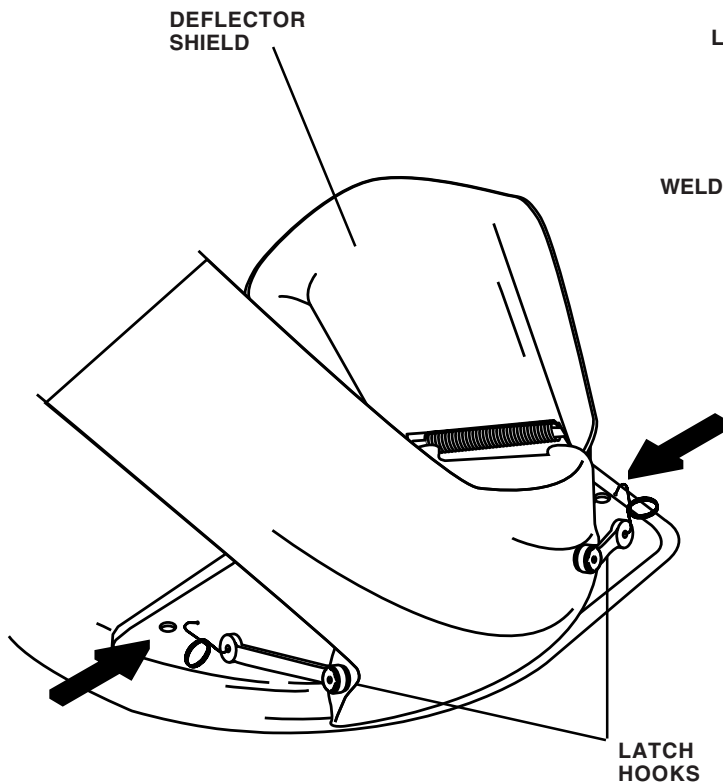

FIG. 7B

ASSEMBLY

8 CHUTE LATCH ASSEMBLY (See Fig. 8)

Use Hardware - - GROUPS "E & F"

- Assemble latch pin to upper chute, as shown.
- Press weld nut into rubber latch and assemble rubber latch to lower chute, as shown.
- Tighten all hardware securely.

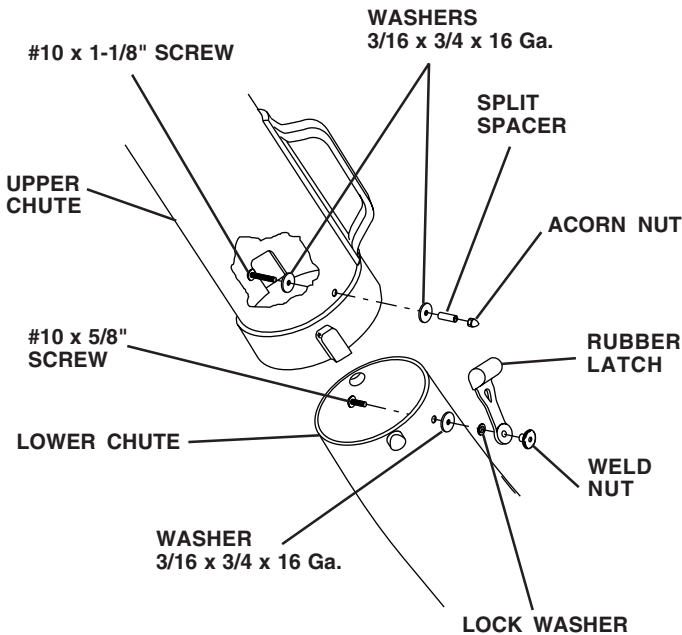

FIG. 8

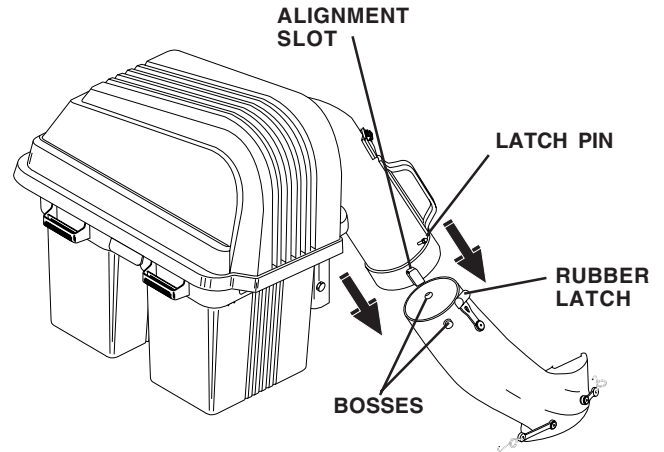

FIG. 9B

10 LEVEL MOWER DECK No hardware required

- Be sure deck is properly leveled for best mower performance. See your tractor's owner's manual for instructions.

9 UPPER CHUTE (See Figs. 9A & 9B) No hardware required

- Lower mower deck to its lowest cutting position.
- Assemble upper chute by inserting curved end into hole in back of cover.

NOTE: Handle carefully so as not to damage dump bag indicator.

- Push in and turn upper chute until it is in line with lower chute.
- Align the bosses on lower chute with alignment slots on upper chute and slide together.
- Secure with rubber latch by hooking hole in latch over latch pin.

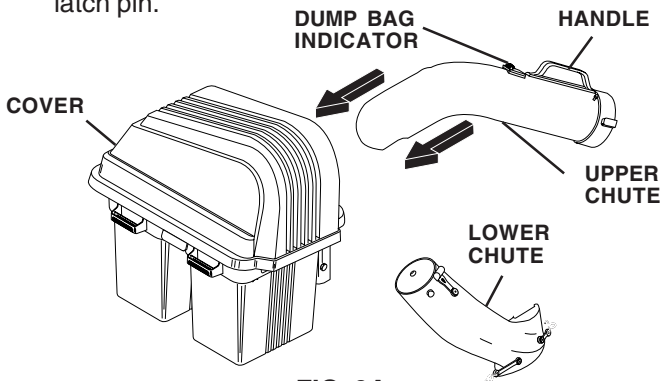

FIG. 9A

OPERATION

TIPS FOR IMPROVED BAGGING OPERATION:

Follow the mower operation instructions in your tractor owner's manual.

When operating your grass catcher on a lawn where grass and leaf bagging equipment has not been used, you are picking up thatch and debris that has accumulated for long periods of time. The amount collected and the total time of operation may be greater than you will experience with regular use of your grass catcher.

- Always run throttle at full speed when bagging.
- Select a gear low enough to give good mower cutting performance, good quality cut and good bagging performance.

NOTE: It may be necessary to overlap width of cut to suit your conditions.

- If grass is extremely tall, it should be mowed twice. The first time relatively high, the second time to desired height.
- Use left hand side of mower for trimming.
- Plastic trash bags can be inserted inside grass catcher containers for ease of debris disposal. To remove the plastic trash bags when full:
 - a. Disengage blades, shift into neutral, engage the parking brake and stop the engine.
 - b. Raise seat. Unlatch and raise cover.
 - c. Remove one container at a time by grasping container handles and pulling toward the rear, off of the tube rails.
 - d. With the container resting on the ground, close and secure the top of the plastic lawn bag.
 - e. Tip the container on its side and slide the filled bag from the container.
 - f. Install a new plastic lawn bag with the edges of the bag draped over upper lip of the Container.
 - g. Repeat for other container.
 - h. Reinstall containers making sure right container overlaps left container at center support.
 - j. Close cover and secure latch over center support tube.

- Avoid cutting wet grass or in the morning while the dew is still heavy. Grass clippings collected under these conditions tend to be sticky and adhere to the walls of the flow path causing clogging.
- Your bagger is equipped with a dump bag indicator. As the bags become full, the flow indicating ball will drop down in its slot, indicating that the bags are full or the chutes have become clogged. Care should be taken not to damage the parts and that the ball moves freely at the beginning of each use.
- If the grass catcher fails to pick up cut grass or leaves, it is an indication that clogging has occurred in the system or that the grass catcher containers are full.
 - a. Disengage blades, shift into neutral, engage the parking brake and stop the engine.
 - Raise seat. Unlatch and raise cover.
 - Slide out containers and dispose of clippings .
 - Replace containers, close cover, and latch.
 - b. Unlatch chutes and check for clogging
 - Remove all debris in chutes.
 - Reassemble and latch chutes
 - c. Check to insure dump bag indicator has not become clogged.
 - The air passage hole must be clear of debris. Gently insert a small twig or wire into passage-way to clear.



CAUTION

- **Do not operate mower with grass catcher partially installed.**
- **Disengage blades and stop engine before leaving tractor seat to empty containers, unclogging chutes, etc.**
- **Close cover before starting.**
- **Disengage mower when crossing driveways or gravel surfaces and other areas where thrown objects could be a hazard.**
- **Do not attempt to vacuum up cans or other potentially hazardous projectiles.**

CUSTOMER RESPONSIBILITIES

GENERAL RECOMMENDATIONS

Always observe safety rules when performing any maintenance.

- Before each use check for loose fasteners.
- Clean unit thoroughly after each use.

BLADE CARE

For best results mower blades must be kept sharp. Replace bent or damaged blades.

- See BLADE CARE instructions in your tractor owner's manual.

STORAGE

When grass catcher is to be stored for a period of time, clean it thoroughly, remove all dirt, grass, leaves, etc. Store in a clean, dry place.



CAUTION: Do not leave grass in bagger containers. Empty containers after each use and before storing. Failure to do so may result in spontaneous combustion which could develop into a fire.



CAUTION: BEFORE PERFORMING ANY MAINTENANCE, SERVICE OR ADJUSTMENTS:

- Depress clutch brake pedal fully and set parking brake.
- Place gearshift/motion control lever in neutral (N) position.
- Place clutch control in "DISENGAGED" position.
- Turn ignition key to "OFF" position.
- Make sure blades and all moving parts have completely stopped.
- Disconnect spark plug wire(s) from spark plug(s) and place wire where it cannot come in contact with plug.



CAUTION: Grass catcher components are subject to wear, damage and deterioration, which could expose moving parts or allow objects to be thrown. Frequently check components and replace with manufacturer's recommended parts, when necessary.

SERVICE NOTES

REPAIR PARTS / PIÈCES DE RECHANGE

GRASS CATCHER -- MODEL NUMBER CL36A / RAMASSE-HERBE -- NUMÉRO DE MODÈLE CL36A
PRODUCT NUMBER 954 12 00-93 / NUMÉRO DE PRODUIT 954 12 00-93

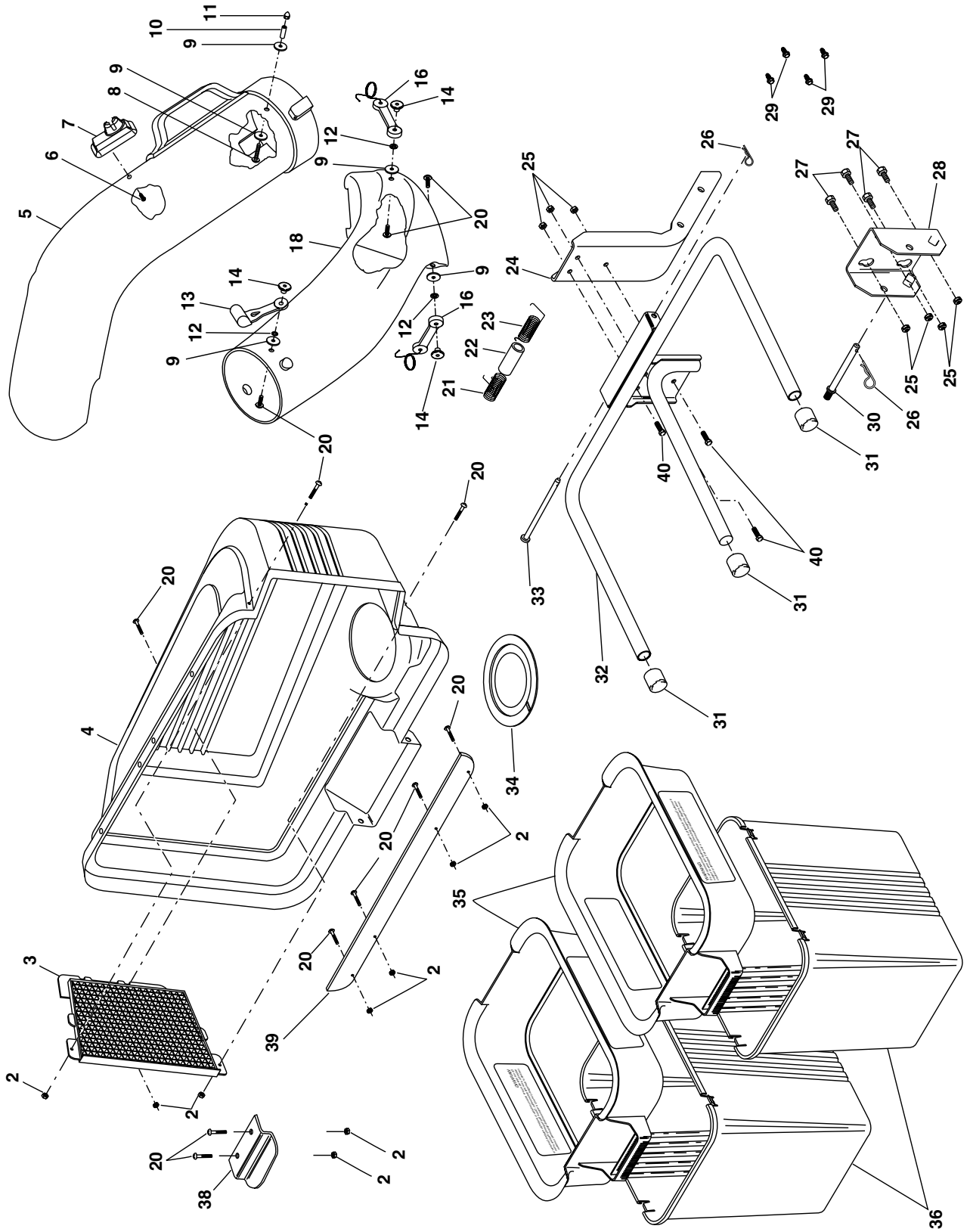

REPAIR PARTS / PIÈCES DE RECHANGE

GRASS CATCHER - - MODEL NUMBER CL36A / RAMASSE-HERBE - - NUMÉRO DE MODÈLE CL36A
 PRODUCT NUMBER 954 12 00-93 / NUMÉRO DE PRODUIT 954 12 00-93

KEY NO.	PART NO.	DESCRIPTION	DESCRIPTION	KEY NO.	PART NO.	DESCRIPTION	DESCRIPTION
2	53269180	Nut, Crownlock #10-24	Écrou auto-serrant #10-24	24	532126813	Post, Support	Poteau de soutien
3	532127533	Screen, Cover	Grillage de couvercle	25	873800500	Locknut 5/16 x 18	Écrou frein 5/16 x 18
4	532161314	Cover Asm. (Incl. 3,38,39)	Couvercle Ens. (Y compris 3,38,39)	26	532124670	Spring, Retainer	Ressort de retenue
5	532128598	Chute, Upper	Glissière supérieure	27	874760512	Bolt, Hex 5/16-18 x 3/4	Boulon H 5/16-18 x 3/4
6	818021008	Screw, Special #10-14x1/2	Vis spéciale #10-14x1/2	28	532170053	Bracket, Mounting	Support de montage
7	532140572	Dump Bag Indicator	Indicateur de sac de déchargement	29	532170165	Shoulder Bolt	Boulon
8	532087175	Screw, #10-24 x 1-1/8	Vis #10-24 x 1-1/8	30	532131137	Pin, Support Post	Goupille du poteau de soutien
9	819061216	Washer #10	Rondelle #10	31	532174083	Plug, Tubing End	Chapeau de l'extrémité de tuyau
10	532007206	Spacer, Split	Entretoise fendue	32	532126919	Bagger, Frame	Cadre de ramasse-herbe
11	532060867	Nut, Acorn #10-24	Écrou borgne #10-24	33	532128600	Pin, Hinge	Goupille de charnière
12	810071000	Washer, lock #10	Rondelle frein #10	34	532127534	Gasket, Cover	Garniture de couvercle
13	532109808	Latch, Chute	Loquet de glissière	35	532129585	Container, Top	Conteneur supérieur
14	532125004	Nut, Weld	Axe du loquet	36	532129586	Container, Bottom	Conteneur inférieur
16	532160793	Latch Hook Asm.	Crochet de loquet	38	532130895	Latch Handle, Cover	Poignée de loquet de couvercle
18	532174570	Chute, Lower	Glissière inférieure	39	532155042	Strip, Reinforcement	Bande
20	871081010	Screw #10-24 x 5/8	Vis #10-24 x 5/8	40	872140506	Carriage Bolt 5/16-18x3/4	Boulon de chariot 5/16-18 x 3/4
21	532132796	Spring, Cover L.H. (black)	Ressort de couvercle C. G.	—	532175732	Owner's Manual	Manuel du propriétaire
22	532133235	Spacer, Cover	Entretoise de couvercle				
23	532132983	Spring, Cover R.H. (gray)	Ressort de couvercle C.D.				