

4800 S Art. 1776

DK Brugsanvisning
Dykpumpe

GB Operating Instructions
Submersible Pump

GARDENA Submersible Pump 4800 S

Welcome to the garden of GARDENA ...



Please read these operating instructions carefully and observe the notes given. Use the instructions to familiarise yourself with the submersible pump, its correct use, and the notes on safety.



For safety reasons, children under 16 as well as persons not familiar with these operating instructions should not use this submersible pump.

→ Keep these operating instructions in a safe place.

Contents

| | |
|--|----|
| 1. Applications Range of Your GARDENA Submersible Pump ... | 8 |
| 2. For Your Safety | 9 |
| 3. Initial Operation | 10 |
| 4. Operation | 11 |
| 5. Cleaning | 11 |
| 6. Trouble-Shooting | 12 |
| 7. Storage | 12 |
| 8. Technical Data | 13 |
| 9. Service | 14 |

1. Applications Range of Your GARDENA Submersible Pump

Intended use

GARDENA Submersible Pumps have been designed for private use around your house and garden. They are predominantly destined for drainage after flooding, transfer of liquids, draining containers, taking water from wells and shafts, draining boats and yachts as well as for water aeration and circulation for a limited period of time.

Liquids to be pumped

Liquids which can be handled by the GARDENA Submersible Pump are the following: clean and slightly contaminated water (max. particle size 5 mm), swimming pool water (prerequisite is the recommended dosage of additives) and soapy water.

The pump is fully submersible (waterproof sealed) and can be immersed in the liquid down to a depth of 9 m.

Please note



The GARDENA Submersible Pumps are not designed for continuous operation (e.g. continuous circulating operation) in a pond. Your pump's life will be shortened correspondingly by such operation.
Corrosive, easily combustible or explosive substances (e.g. gasoline, petroleum, nitro thinner), fats, oils, salt-water and waste water of toilets and urinals must not be pumped.
The temperature of the liquid handled should not exceed 35°C.

2. For Your Safety

Residual-current device

According to DIN VDE (German Electrical Engineers' Association) 0100, submersible pumps may only be used in swimming pools, garden ponds, and fountains if the pump is operated via a residual-current device with a residual-current rating of ≤ 30 mA. The pump must not be operated when there are persons in the swimming pool or garden pond.

For safety reasons we recommend that you always operate the submersible pump via a residual-current device (DIN VDE 0100-702 and 0100-738).

→ Please contact your electrician.

Mains power

According to DIN VDE (German Electrical Engineers' Association) 0620, mains power cables must not have a smaller cross-section than the rubber-sheathed cables of the designation H05 RNF. The cable length must be at least 10 m.

Data indicated on the type plate must match technical data of the mains supply.

→ Take care that the electrical connections are made within dry area, protected from flooding.

Protect plug and power cable from heat, oil and sharp edges.

→ Don't use the power cable for plugging off.

The power cable or the float switch must not be used for mounting or relocating the pump. For submerging or lifting/securing the pump, fix a rope to the pump's carrying handle.

→ Extension cables must meet the requirements of DIN VDE 0620.

Visual check

→ Before operating the pump, first make a visual check, if there is any damage of the pump (esp. regarding power cable and plug).

→ Observe the minimum water level and the max. delivery height (see 8. Technical Data).

A damaged pump must not be used.

→ In case of damage, please have the pump checked by our GARDENA Service Centre.

Manual operation

During manual operation, the pump must be switched off as soon as all the liquid has been pumped away.

→ Observe the pump at all times during manual operation.

Notes on use

→ Clear the outlet line before use.

Dry-running operation causes increased wear and is to be avoided. Therefore, in manual operation the pump must be immediately unplugged when water fails to flow.

Avoid running of the pump for more than 10 min. against closed delivery side of the pump.

Sand and other abrasive substances cause increased wear and reduce the pump's output.

Take care that the pump is located where the inlet openings at the suction base are obstructed neither completely nor partly.

Stand the pump on a brick if using in a pond.

Thermal motor protector

The pump is automatically switched off on overheating by the built-in thermal motor protector. After having cooled down, the motor automatically switches on again (see 6. Trouble Shooting).

Automatic deaerating valve

→ The automatic deaerating valve eliminates any air pockets in the pump. If the water level drops below the vent valve, some water flows penetrates outside through the vent valve ④.

This is not a defect of your pump, but serves to deaerate the pump.

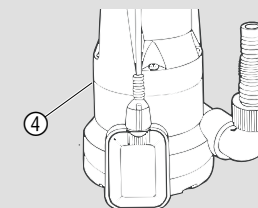

3. Initial Operation

| Hose diameter | 13 mm (1/2") 15 mm (5/8") 19 mm (3/4") | 25 mm (1") | 38 mm (1 1/2") |
|---------------|--|------------|----------------|
|---------------|--|------------|----------------|

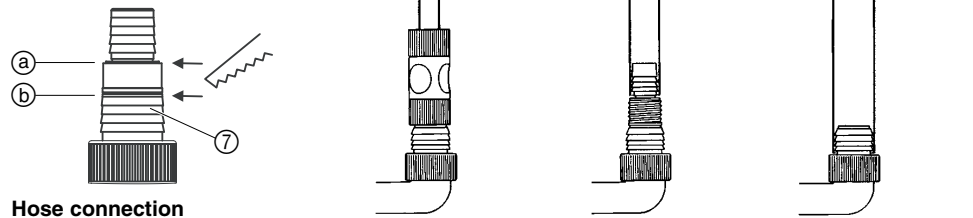

Hose connection of universal fitting ⑦

| Hose connection | Cut off topmost nipple at ①. | Do not cut off any nipples. | Cut off top two nipples at ②. |
|-----------------|---|-----------------------------|-------------------------------|
| | The following connection kits are required for 13 mm to 19 mm connections: 13 mm (1/2"): GARDENA Pump Connection Set, Art. No. 1750 15 mm (5/8"): GARDENA Tap Connector, Art. No. 902 , and Standard Hose Connector, Art. No. 916 19 mm (3/4"): GARDENA Pump Connection Set, Art. No. 1752 | | |
| | Best results in delivery capacity are achieved when using 38 mm (1 1/2") hoses. | | |

Connecting the hose:

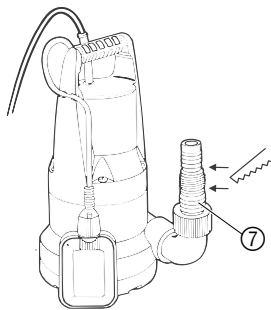

- The universal fitting ⑦ allows you to connect all the hoses listed in the previous table.
1. Cut off nipples of the universal fitting ⑦, which are not needed, to match the hose connection.
 2. Screw the universal fitting ⑦ onto the pump.
 3. Connect the hose to the universal fitting ⑦.
- We recommend that you secure 32 mm (5/4") and 25 mm (1") hoses additionally with a **GARDENA Hose Clip Art. No. 1591**.

Only for 13 mm (1/2") hose:
The universal fitting ⑦ can also be equipped with a **GARDENA Regulator Valve Art. No. 977** so that the contents of the outlet line do not flow back through the pump after pumping. The Regulator Valve can be ordered from GARDENA Service.

4. Operation

Automatic operation:

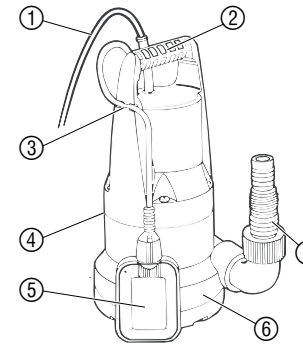

To ensure that the pump draws the water out, the water to be drained must be at least 45 mm deep.

The float switch ⑤ turns the pump on automatically when the water level exceeds the cut-in height and the water is pumped out.

The float switch ⑤ turns the pump off again as soon as the water level falls below the cut-out height.

1. Stand the pump on a firm surface – or – use a rope attached to the carrying handle ② to immerse the pump in a well or shaft.
During automatic operation, ensure that the float switch ⑤ can move freely.
2. Plug the power cable ① into a mains socket.

Adjusting the Cut-in and Cut-out Height:

The maximum cut-in height and minimum cut-out height (see 8. Technical Data) can be adjusted.

→ Push the cable of the float switch ⑤ into the float switch lock ③.
Do not select a cable length that is too long or short to ensure that the float switch can turn on and off properly.

- The shorter the length of cable between the float switch ⑤ and the float switch lock ③, the lower the cut-in height and the higher the cut-out height.

Manual operation:

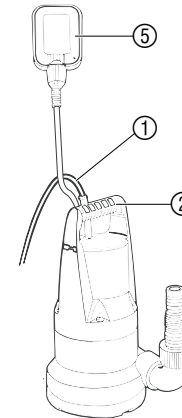

The pump remains in constant operation because the float switch is bypassed.

1. Stand the pump on a firm surface – or – use a rope attached to the carrying handle ② to immerse the pump in a well or shaft.
2. Plug the power cable ① into a mains socket.
3. Fix float switch ⑤ vertically above the pump (with the cable at the bottom).
As long as the float switch is positioned vertically above the pump, the pump will operate regardless of the water level.

The residual water height of approx. 5 mm is only reached during manual operation since the float switch turns off the pump during automatic operation before this water level is reached.

5. Cleaning

Flushing the Pump:

The pumps are virtually maintenance-free.

After having pumped chlorinated swimming pool water or other liquids leaving residues, the pump should be rinsed with clear water.

Cleaning the suction base and turbine:

Warning! Electric shock!
Risk of injury due to electric shock.
→ Disconnect the pump from the mains before cleaning the suction base and turbine.

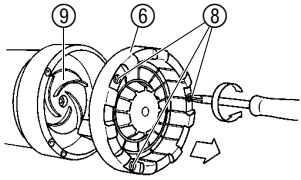

1. Unscrew the 3 Phillips screws ⑧ and pull the suction base ⑥ off the pump.
2. Clean the suction base ⑥ and the turbine ⑨.
3. Reinstall the suction base ⑥ and screw in the Phillips screws ⑧.

For safety reasons a damaged turbine ⑨ can only be exchanged by the GARDENA Service Centre.

6. Trouble-Shooting

| Problem | Probable cause | Remedy |
|---|--|---|
| Pump is running, but doesn't deliver. | Air cannot escape, since pressure line is closed. | → Open pressure line (e.g. kinked pressure pipe). |
| | Air locks in the suction base. | → Wait for max. 60 seconds until the pump deaerates automatically over the vent valve. If necessary, switch off and start it again. |
| | Turbine clogged. | → Disconnect plug and clean turbine (see 5. Cleaning). |
| | When starting the pump, water height falls below the min. water level. | → Submerge pump deeper. |
| Pump doesn't start or suddenly stops during operation. | Thermal overload switch has switched the pump off due to overheating. | → Disconnect plug and clean turbine (see 5. Cleaning). Observe max. media temperature of 35 °C. |
| | No power. | → Check fuses and electric connections. |
| | Dirt particles are jammed in the suction base. | → Disconnect plug and clean suction base (see 5. Cleaning). |
| Pump runs, but output suddenly decreases. | Suction base is clogged. | → Disconnect plug and clean suction base (see 5. Cleaning). |



Attention!

Repairs on electrical parts should only be done by our GARDENA Service Centres.

If you have any problems with your Pump, please contact our Service.

7. Storage

Frost-free storage

Store the pump away from frost before the first frost sets in.

8. Technical Data

| | |
|--|--|
| Type | 4800 S (Art. No. 1776-24) |
| Rated power | 190 W |
| Max. delivery capacity | 4,800 l/h |
| Max. pressure | 0.5 bar |
| Max. delivery height | 5 m |
| Max. submersion depth | 9 m |
| Flat suction down to approx. | 5 mm |
| Contaminated water with particle size of max. | 5 mm |
| Power cable | 10 m H05 RNF |
| Pump connection | 38 mm (1 1/2") / 25 mm (1") graduated nipple, option GARDENA Water hose Plug-in-system |
| Min. water level for operation | 45 mm |
| Weight approx. | 4.0 kg |
| Max. media temperature | 35 °C |
| Mains voltage / mains frequency | 230 V / 50 Hz |
| Min. cut-in height | 380 mm |
| Min./max. cut-out height | 100 mm / 140 mm |
| Noise level $L_{WA}^{1)}$ | 46 dB (A) |

1) Measuring method according to EN 60335-1

Cut-in / Cut-out height

The cut-in and cut-out height varies.

The residual water depth (draining in the flat position down to approx. 5 mm) is only reached during manual operation (see 4. Operation).

Performance characteristics

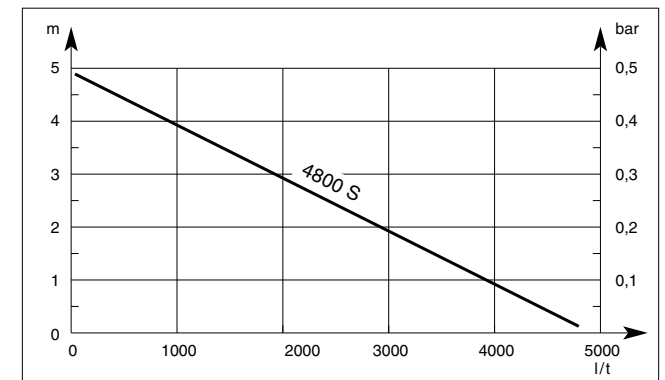

9. Service

Warranty

GARDENA guarantees this product for 2 years (from date of purchase). This guarantee covers all serious defects of the unit that can be proved to be material or manufacturing faults. Under warranty we will either replace the unit or repair it free of charge if the following conditions apply:

- The unit must have been handled properly and in keeping with the requirements of the operating instructions.
- Neither the purchaser or a non-authorised third party have attempted to repair the unit.

The turbine is a wearing part and is not covered by the guarantee.

This manufacturer's guarantee does not affect the user's existing warranty claims against the dealer/seller.

If you have any problems with your pump, please contact our Customer Service or return the defective unit together with a short description of the problem directly to one of the GARDENA Service Centres listed on the back of this leaflet.

DK Produktansvar

Vi gør udtrykkeligt opmærksom på, at i henhold til produktansvarlovgivningen er vi ikke ansvarlige for skader forårsaget af produktet, hvis skaden sker på grund af uautoriserede reparationer, eller hvis dele er skiftet ud og der ikke er anvendt originale GARDENA dele eller dele godkendt af os, eller hvis reparationerne ikke er udført af GARDENA service eller en autoriseret fagmand. Det samme gælder for ekstraudstyr og tilbehør.

GB Product Liability

We expressly point out that, in accordance with the product liability law, we are not liable for any damage caused by our units if it is due to improper repair or if parts exchanged are not original GARDENA parts or parts approved by us, and, if the repairs were not carried out by a GARDENA Service Centre or an authorised specialist. The same applies to spare parts and accessories.

| | | | |
|---|---|---|---------|
| DK EU Overensstemmelse certifikat Undertegnede GARDENA Kress + Kastner GmbH, Hans-Lorenser-Str. 40, D-89079 Ulm bekræfter hermed, at enheder listet herunder, ved afsendelse fra fabrikken, er i overensstemmelse med harmoniserede EU retningslinier, EU sikkerhedsstandarder og produktspecifikationsstandarder. Dette certifikat træder ud af kraft hvis enhederne er ændret uden vor godkendelse. | Beskrivelse af enhederne: Description of the unit: | Dykpumpe Submersible Pump | |
| | Type: 4800 S Type: | Varenr. : Art. No.: | 1776-24 |
| GB EU Certificate of Conformity The undersigned GARDENA Kress + Kastner GmbH, Hans-Lorenser-Str. 40, D-89079 Ulm, hereby certifies that, when leaving our factory, the unit indicated below is in accordance with the harmonised EU guidelines, EU standards of safety and product specific standards. This certificate becomes void if the unit is modified without our approval. | EU direktiv: EU directives: | 98/37/EC 89/336/EC 73/23/EC 93/68/EC | |
| | CE-Mærkningsår: Year of CE marking: | 2002 | |
| | |  Thomas Heintl Teknisk direktør Technical Dept. Manager | |
| | Ulm, 10.12.2002 Ulm, 10.12.2002 | | |

Deutschland

GARDENA Kress + Kastner GmbH
GARDENA Service
Hans-Lorensen-Straße 40
D-89079 Ulm
Produktfragen: (07 31) 490-123
Reparaturen: (07 31) 490-290

Argentina

Argensem S.A.
Venezuela 1075
(1618) El Talar - Buenos Aires

Australia

NYLEX Consumer Division
76-88 Mills Road
P.O. Box 722
Braeside 3195
Melbourne, Victoria

Austria

GARDENA Österreich Ges. m.b.H.
Stettnerweg 11-15
2100 Korneuburg

Belgium

MARKT (Belgium) NV/SA
Sterrebeekstraat 163
1930 Zaventem

Brazil

M. Cassab
Av. das Nações Unidas, 20.882
Santo Amaro, CEP 04795-000
São Paulo - S.P.

Bulgaria / България

ДЕНЕКС ООД
Бул. "Г.М.Димитров" 16 ет.4
София 1797

Canada

GARDENA Canada Ltd.
100 Summerlea Road
Brampton, Ontario
Canada L6T 4X3

Chile

Antonio Martinic Y CIA. LTDA.
Gilberto Fuenzalida 185 Loc.
Las Condes - Santiago de Chile

Costa Rica

Compania Exim
Euroiberoamericana S.A.
Av. 12 bis Calle 16 y 18
Bodegas Keith y Ramirez
San José

Cyprus

FARMOKIPIKI LTD
P.O. Box 7098
74, Digeni Akrita Ave.
1641 Nicosia

Czech Republic

GARDENA spol. s.r.o.
Řípská 20a, č.p. 1153
62700 Brno

Denmark

GARDENA Danmark A/S
Naverland 8
2600 Glostrup

Finland

Habitec Oy
Martinkyläntie 52
01720 Vantaa

France

GARDENA France
Service Après-Vente
BP 50080
95948 ROISSY CDG Cedex

Great Britain

GARDENA UK Ltd.
27-28 Brenkley Way
Blezard Business Park
Seaton Burn
Newcastle upon Tyne NE13 6DS

Greece

Agrokip G. Psomadopoulos & Co.
33a, Ifestou str.
Koropi 194 00
Athens

Hungary

GARDENA Magyarország Kft.
Késmárk utca 22
1158 Budapest

Iceland

Heimilistaeki hf
Saetun 8
P.O. Box 5340
125 Reykjavik

Republic of Ireland

Michael McLoughlin & Sons
Hardware Limited
Long Mile Road
Dublin 12

Italy

GARDENA Italia S.r.l.
Via Donizetti 22
20020 Lainate (Mi)

Japan

KAKUDAI Mfg. Co. Ltd.
1-4-4, Itachibori Nishi-ku
Osaka 550

Luxembourg

Magasins Jules Neuberger
Grand Rue 30
Case Postale No. 12
Luxembourg 2010

Netherlands

GARDENA Nederland B.V.
Postbus 50176
1305 AD ALMERE

Neth. Antilles
Jonka Enterprises N.V.
Sta. Rosa Weg 196
P.O. Box 8200
Curaçao

New Zealand

NYLEX New Zealand Limited
Private Bag 94001
South Auckland Mail Centre
10 Offenhauser Drive
East Tamaki, Manukau

Norway

GARDENA Norge A/S
Postboks 214
2013 Skjetten

Poland

GARDENA Polska Sp. z o.o.
Szymanów 9 d
05-532 Baniocha

Portugal

GARDENA, Lda.
Recta da Granja do Marquês
Edif. GARDENA
Algueirão
2725-596 Mem Martins

Russia / Россия

АО АМИДА ТТЦ
ул. Мосфилмовская 66
117330 Москва

Singapore

Variware
Holland Road Shopping Centre
227-A 1st Fl., Unit 29
Holland Avenue
Singapore 1027

Slowenia / Croatia

Silk d.o.o. Trgovina
Brodišče 15
1236 Trzin

South Africa

GARDENA South Africa (Pty.) Ltd.
P.O. Box 11534
Vorna Valley 1686

Spain

ANMI Andreu y Miriam S.A.
Calle Pere IV, 111
08018 Barcelona

Sweden

GARDENA Svenska AB
Box 9003
20039 Malmö

Switzerland

GARDENA Kress + Kastner AG
Bitziberg 1
8184 Bachenbülach

Ukraine / Украина

АОЗТ АЛЪЦЕСТ
ул. Гайдара 50
г. Киев 01033

Turkey

Dost Dış Ticaret Müessesilik A.Ş.
Yeşilbağlar Mah. Başkent
Cad. No. 26
Pendik - İstanbul

USA

GARDENA
3085 Shawnee Drive
Winchester, VA 22604

1776-24.960.01/0021

© GARDENA Kress + Kastner GmbH
Postfach 27 47, D-89070 Ulm
<http://www.gardena.com>