

 **Electrolux**

40cm
CORDLESS
24V
BATTERY

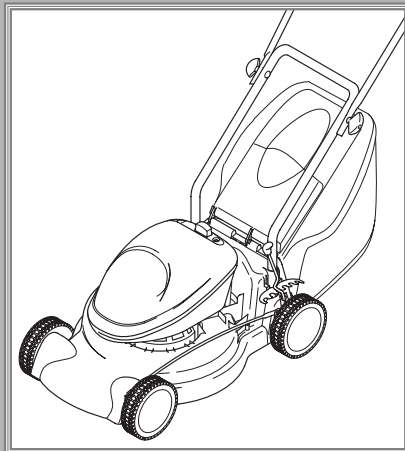
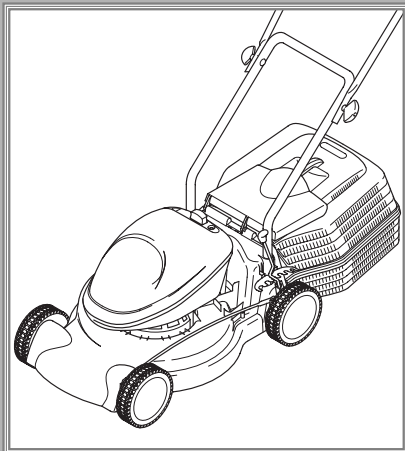

GB

IMPORTANT INFORMATION

Read before use and retain for future reference

D

WICHTIGE INFORMATION

Bitte vor dem Benutzen des Gerätes durchlesen und gut aufbewahren

F

RENSEIGNEMENTS IMPORTANTS

A lire avant usage et à conserver pour référence ultérieure

NL

BELANGRIJKE INFORMATIE

Leest u deze informatie voor het gebruik en bewaar ze voor toekomstige raadpleging

N

VIKTIG INFORMASJON

Les bruksanvisningen nøye før bruk og oppbevar den for senere bruk

SF

TÄRKEÄÄ TIETOA

Lue tämä ennen käyttöä ja säilytä myöhempää tarvetta varten

S

VIKTIG INFORMATION

Läs anvisningarna före användningen och spara dem för framtida behov

DK

VIGTIGE OPLYSNINGER

Du bør læse brugsanvisningen før brug og gemme til senere henvisning

E

INFORMACIÓN IMPORTANTE

Léase antes de utilizar y consérvela como referencia en el futuro

P

INFORMAÇÕES IMPORTANTES

Leia antes de utilizar e guarde para consulta futura

I

INFORMAZIONI IMPORTANTI

Leggere prima dell'uso e conservare per ulteriore consultazione

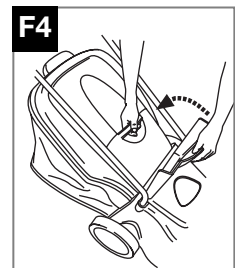
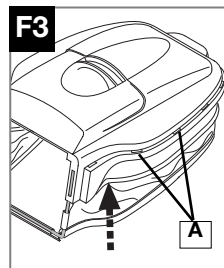
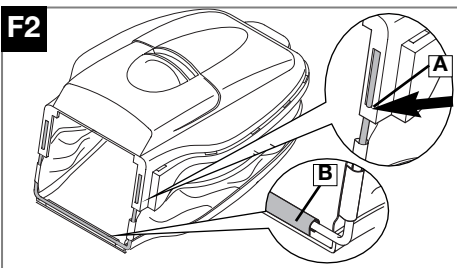
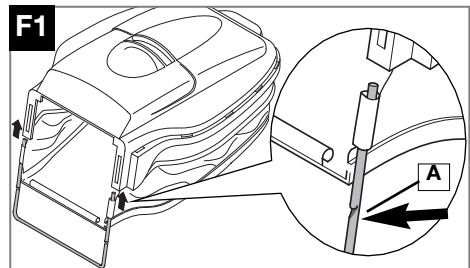
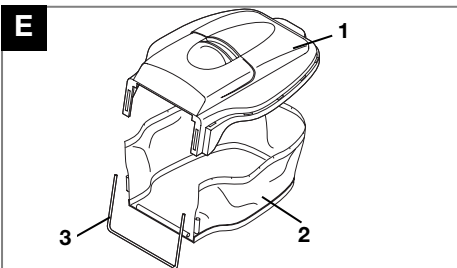
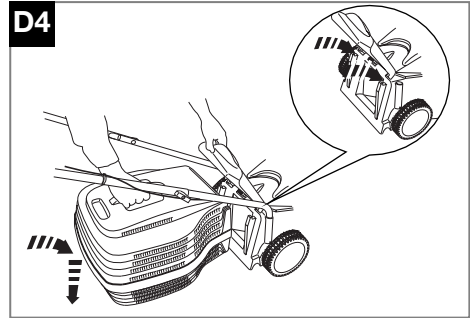
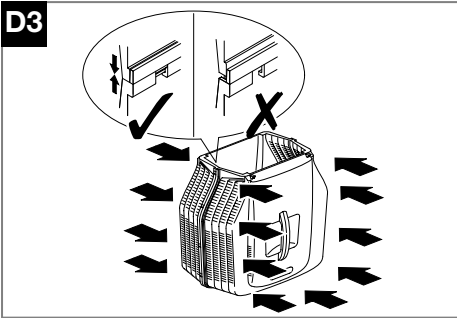
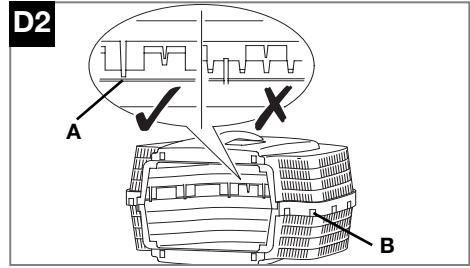
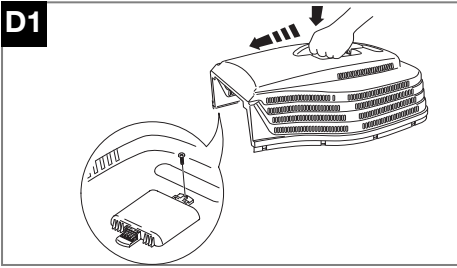
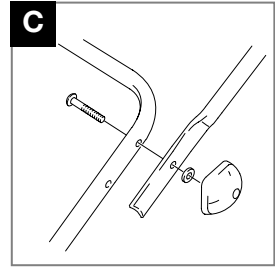
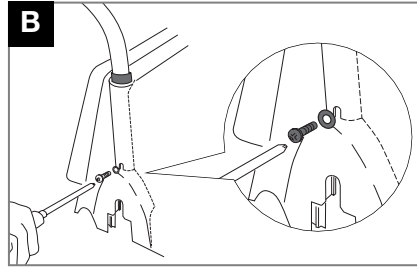
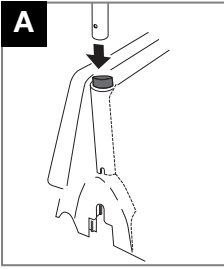

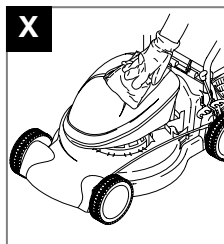
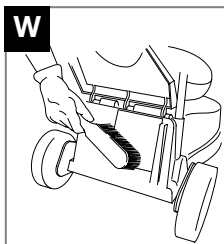
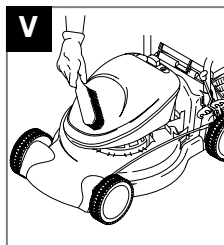
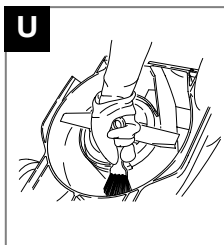
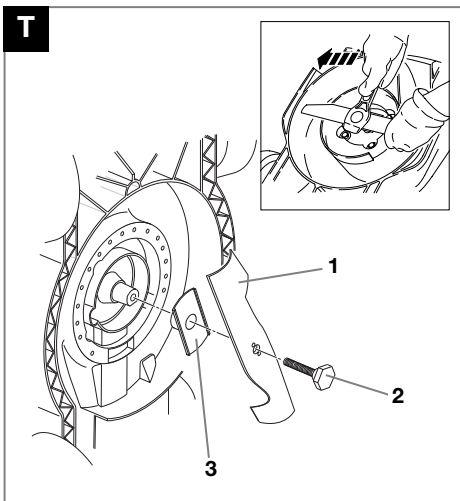
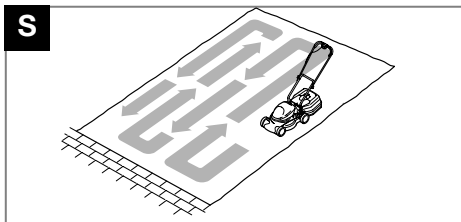
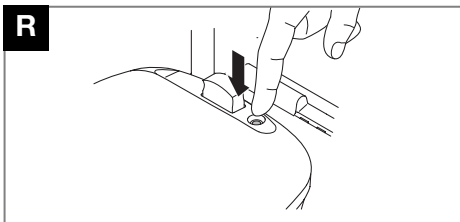
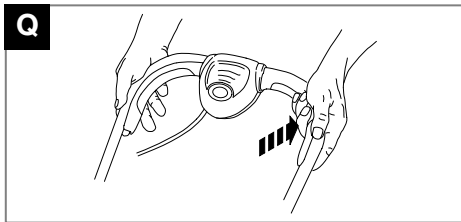
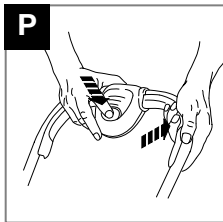
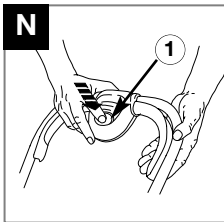
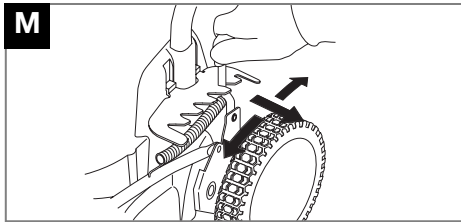
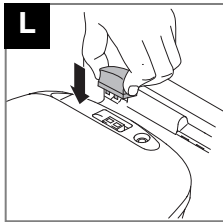
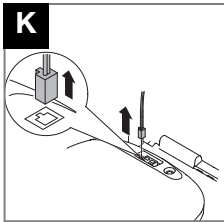
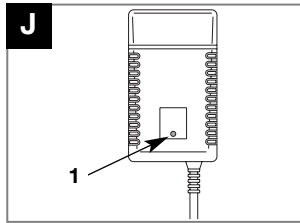
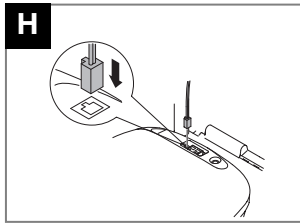
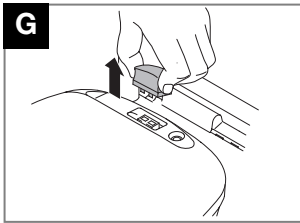

Safety Precautions



If not used properly this lawnmower can be dangerous! This lawnmower can cause serious injury to the operator and others, the warnings and safety instructions must be followed to ensure reasonable safety and efficiency in using this lawnmower. The operator is responsible for following the warning and safety instructions in this manual and on the lawnmower.
Never use the mower unless the grassbox or guards provided by the manufacturer are in the correct position.

Explanation of Symbols on your 40cm Cordless



Warning

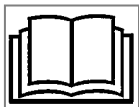

Read the user instructions carefully to make sure you understand all the controls and what they do.



Always keep the lawnmower on the ground when mowing. Tilting or lifting the lawnmower may cause stones to be thrown out

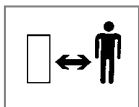

Keep bystanders away. Do not mow whilst people especially children or pets are in the mowing area



Switch off! Remove charger plug cable from mains before adjusting, cleaning or if cable is entangled or damaged. Keep the cable away from the blade.



Remove the safety key before attempting any maintenance, cleaning or adjustment, or if you are going to leave the lawnmower unattended for any period.

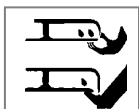

Beware of severing toes or hands. Do not put hands or feet near a rotating blade.



Blade continues to rotate after the machine is switched off. Wait until all machine components have completely stopped before touching them



Do not mow in the rain or leave the lawnmower outdoors while raining

General

1. Never allow children or people unfamiliar with these instructions to use the mower. Local regulations may restrict the age of the operator.

2. Only use the lawnmower in the manner and for the functions described in these instructions.
3. Never operate the lawnmower when you are tired, ill or under the influence of alcohol, drugs or medicine.
4. The operator or user is responsible for accidents or hazards occurring to other people or their property.

Preparation

1. Do not mow barefoot or in open sandals. Always wear suitable clothing, gloves, and stout shoes.
2. Make sure the lawn is clear of sticks, stones, bones, wire and debris; they could be thrown by the blade.
3. Before using always visually inspect to see that blades, blade bolts and cutter assembly are not worn or damaged. Replace worn or damaged blades together with their fixings in sets to preserve balance.

Electrical Safety

1. Check the charger cable regularly for damage or deterioration due to age.
2. Do not use the lawnmower if the charging cable is not in good condition.
3. Keep children away from the lawnmower when it is connected to the power supply, e.g. during recharging and during normal operation.
4. If the blade strikes a hard object, stop the lawnmower and remove the safety key. Check that the blade shaft has not been bent. This will cause severe vibration and may result in the blade becoming loose. Repair any damage before using the lawnmower again.
5. Before carrying out any repairs or adjustments, stop the lawnmower and remove the safety key.
6. Never leave the lawnmower unattended with the safety key in place.

Battery Safety

1. The batteries are sealed lead accumulators which contain corrosive acid. If you get acid on your skin or in your eyes wash it off immediately, and seek medical advice.
2. Batteries that are no longer useful must be disposed of responsibly (see Disposal).
3. Avoid touching the battery terminals with anything metallic.
4. Do not store or charge batteries any where near chemicals.

Use

1. Use the lawnmower only in daylight or good artificial light.
2. Avoid operating your lawnmower in wet grass, where feasible.
3. Take care in wet grass, you may lose your footing.

Safety Precautions

- Mowing on banks and slopes can be dangerous. Do not mow on **banks** or **steep** slopes.
- On slopes, be extra careful of your footing and wear non-slip footwear.
- Mow across the face of slopes, never up and down.
- Exercise extreme caution when changing direction on slopes.
- Do not walk backwards when mowing, you could trip. Walk never run.
- Never cut grass by pulling the mower towards you.
- Stop the lawnmower and remove the safety key before moving the lawnmower across surfaces other than grass and when transporting the lawnmower to and from the area to be mowed.
- Never operate the lawnmower with damaged guards or without guards in place.
- Always start the lawnmower carefully with feet well away from the blades.
- Do not tilt the lawnmower when the motor is running, except when starting and stopping. In this case, do not tilt more than absolutely necessary and lift only the part which is away from the operator. Always ensure that both hands are in the operating position before returning the appliance to the ground.
- Do not stand in front of the grass discharge chute when you start the motor.
- Do not put hands near the grass discharge chute whilst the motor is running.
- Never pick up or carry a lawnmower while the motor is running.
- Stop the lawnmower and remove the safety key:
 - before leaving the mower unattended for any period;
 - before clearing a blockage;
 - before checking, cleaning or working on the appliance;
 - if you hit an object. Do not use your lawnmower until you are sure that the entire lawnmower is in a safe operating condition;
 - if the lawnmower starts to vibrate abnormally. Check immediately. Excessive vibration can cause injury.

Maintenance and storage

- Keep all nuts, bolts and screws tight to be sure the lawnmower is in safe working condition.
- Check the grassbox/grassbag frequently for wear or deterioration.
- Replace worn or damaged parts for safety.
- Only use the replacement blade, blade bolt and blade adaptor specified for this product.
- Allow the motor to cool before storing in any enclosure.
- To reduce fire hazard, keep the motor, battery compartment and storage area free of grass, leaves or excessive grease.
- Be careful during adjustment of the machine to prevent entrapment of the fingers between moving blades and fixed parts of the machine.
- Store in a cool, dry place where your lawnmower is protected from damage.

Transport Safety

- Remove the safety key to prevent accidental starting.
- Carefully fold the handle onto the machine.
- Make sure the cable is not trapped.

Handle Assembly

Assembly of Lower Handles to Deck

- Put Height of Cut Lever into highest cutting position.
- Insert lower handles into deck as shown in **Fig A**.
- Push each handle firmly down until it is located securely into the deck (**B**).
- Insert screw through the washer and into holes using a pozidrive screwdriver and tighten fully into deck as shown in **Fig B**.

Fitting Upper Handles to Lower Handles (C)

- Ensure the upper handle is located correctly with the lock-off button on the switchbox uppermost.
- Ensure the upper handle and the lower handle are aligned correctly.
- Fit the bolts, washers and handle knobs.
- Fit the cables to the handles with the cable ties provided, making sure the cables are not trapped between the upper and lower handles.

Grassbox Assembly - Plastic Box

D2-A - location point

D2-B - clips

Plastic Box

- Insert the grassbox handle into the top of one of the grassbox halves. Press firmly down and forward until the handle clicks into position (**D1**).
- Turn the grassbox half over and insert screw into hole (**as illustrated in fig D1**) and tighten fully.
- Position the two grassbox halves together and press each location point (**D2**) into position **without** fully connecting the clips. When the

location points are matched correctly firmly press the grassbox together until all clips are securely connected. (**D3**)

- To attach the grassbox to your lawnmower, lift the safety flap (**D4**) and make sure the discharge chute is clean and free from debris.
- Locate fully assembled grassbox onto 2 location points at the rear of the deck (**D4**).
- Locate safety flap onto the top of the grassbox. Ensure the grassbox is securely located. (**D4**)
 - Removal is the reverse procedure.

Grassbox Assembly - Fabric Bag

E1 - top

E2 - fabric bac

E3 - 'U' frame

1. Insert 'U' frame through side sleeves of fabric bag and then into the hard top, ensuring the small metal pip (**F1-A**) is securely located (**F2-A**).
2. Attach lower sleeve of fabric bag to 'U' frame (**F2-B**).
3. Starting at front end of the top (**F3**), insert the fabric bag rim into the inside edge of the top until it clicks into each of the location points (**F3-A**). Keep inserting the rim around the top until the fabric bag is secure.
4. Locate fully assembled grassbox onto 2 location points at the rear of the deck.
5. Locate safety flap onto the top of the grassbox (**F4**). Ensure the grassbox is securely located.
 - Removal is the reverse procedure.

Please Note: Ensure no gap remains between the safety flap and the grassbox/bag. Where grass collection is not required you can use the lawnmower without the grassbox/bag. Ensure the safety flap is fully closed.

Battery Charging

J1 - Indicator lamp

CHARGE THE BATTERY

- Before using for the first time
 - If your lawnmower is not used for more than one month.
 - **ALWAYS** charge the battery immediately after use!
 - The battery should be charged for 18 hours before use.
 - Re-charge your battery immediately after use for the full 18 hour charging period.
 - It is recommended that the battery is left on charge permanently, whilst not in use. There is no risk of overcharging.
 - Use the charger indoors only.
 - Ensure the charger is not exposed to moisture. Keep the charger and the battery dry at all times. Keep the charger well ventilated during charging.
1. Remove the safety key (**G**).
 2. Connect the charger to the lawnmower (**H**).
 3. Plug the charger into a suitable household electrical wall socket and switch on.
 4. The red indicator lamp glows continuously during charging. (**J**)
5. Full charge will be achieved in 18 hours. During charging the charger becomes warm. This is normal and means the charger is operating correctly.
- When the battery is fully charged the red indicator lamp change to green and flash briefly. After the brief flashing period the green light stays on permanently to indicate the battery is re-charged and is now receiving a trickle charge.

BEFORE USE

1. Switch off at the mains and disconnect charger from lawnmower. (**K**)
 2. Replace the safety key. (**L**)
- Avoid running the lawnmower into "deep" discharge, i.e. avoid flattening the battery completely.
 - Charging the battery according to these instructions should ensure maximum battery life.
 - **Only use the charger supplied with this product. Do not use it for any other purpose.**

Cutting Height Adjustment

1. Adjust to the desired cutting height by means of the lever on the left side of the mower (**M**).

Starting and Stopping

To Start your Lawnmower

1. Make sure the safety key is in place before starting.
 2. Tilt the handle downwards to slightly raise the front of the lawnmower and to reduce the risk of lawn damage whilst starting.
- The switchbox is provided with a lock-off button (N1) to prevent accidental starting.**
3. Press and hold the lock-off button (**N**) on the switchbox, then squeeze one of the Start/ Stop levers towards the upper handle (**P**).
 4. Continue to squeeze the start/stop lever towards the upper handle and release the lock-off button (**Q**).
 5. Lower the lawnmower to its proper operating position and commence mowing.
- **NOTE - There are two start/stop levers fitted. Either one can be used for starting the lawnmower.**
- To Stop your Lawnmower**
1. Release the pressure on the Start/Stop lever.

Automatic Overload Cutout

This lawnmower is fitted with an overload cutout switch (**R**). If the motor stops: release the start/stop lever, wait 20 seconds then press the cutout reset button. If your lawnmower persistently cuts out, without being unduly loaded consult your nearest Service Centre.

NOTE: Increasing the height of cut will help prevent motor overload.

How to Mow

1. Start mowing from the outside edge of the lawn, mowing in strips in alternate directions (**S**).
2. Mow twice a week in the growing season, your lawn will suffer if more than one third of its length is cut at one time and this may also result in poor collection.

Please Note:-

Do not overload your Lawnmower

When mowing in long thick grass a first cut with the cutting height adjusted to its highest setting, see **Cutting Height Adjustment**, will help reduce motor overload and will help prevent damage to your lawnmower.

Cutting System

T1 - blade

T2 - blade bolt

T3 - blade adaptor

Removing the Blade

1. To remove the blade bolt, hold the blade firmly and with the spanner provided loosen the blade bolt by turning it anti-clockwise (**T**).
2. Remove the blade bolt and blade. (**T**)
3. Inspect for damage and clean as necessary.

Fitting the Blade

1. Ensure the blade adaptor is located correctly. (**T**)
2. Fit the blade to the blade adaptor with the sharp edges of the blade pointing away from the blade adaptor.
3. Re-assemble blade bolt through blade and blade adaptor.
4. Hold the blade firmly and tighten blade bolt

firmly with the spanner provided. Do not over tighten.

5. Do not use a longer spanner.

WARNING!

Before cleaning, servicing or repairing the lawnmower ALWAYS remove the safety key to prevent unintentional starting.

Always handle the blade with care - sharp edges could cause injury.

USE GLOVES.

Renew your metal blade after 50 hours mowing or 2 years whichever is the sooner - regardless of condition.

If the blade is cracked or damaged replace it with a new one.

Never use a blade bolt if the insulated head is damaged cracked or missing.

Caring and Cleaning

Cleaning (U, V, W & X)

1. Remove grass from under the deck with brush.
2. Using a soft brush - remove grass clippings from all air intakes, the discharge chute and the grass box.
3. Wipe over the surface of your lawnmower with a dry cloth.

At the End of the Mowing Season

1. Replace blade, bolts, nuts or screws, if necessary.
2. Clean your lawnmower thoroughly.

Storing your Lawnmower

1. Remove safety key before storing
2. Do not store your lawnmower immediately after use.
3. Wait until the motor has cooled to avoid a potential fire hazard.
4. Put lawnmower on charge.
5. Store in a cool, dry place where your lawnmower is protected from damage.

Changing the battery

1. Contact your local approved service centre when the batteries need to be replaced.
2. Do not adjust any of the wiring or connections.
3. The batteries are sealed lead batteries that contain corrosive acid. If the acid should come into contact with the eyes, rinse thoroughly with plenty of water and seek medical attention. If the acid comes into contact with the skin, rinse thoroughly with plenty of water and protect the eyes from possible splashing.

• IMPORTANT

It is very important that you keep your lawnmower clean. Grass clippings left in any of the air intakes or under the deck could become a potential fire hazard.

• IMPORTANT

Never use water for cleaning your lawnmower. Do not clean with chemicals, including petrol, or solvents - some can destroy critical plastic parts.

Environmental Information

Electrolux Outdoor Products are manufactured under an Environmental Management System (ISO 14001) using, where practical, components manufactured in the most environmentally responsible manner, according to company procedures, and with the potential for recycling at the end of the products' life.

- Packaging is recyclable and plastic components have been labelled (where practical) for categorised recycling.
- Awareness of the environment must be considered when disposing of 'end-of-life' product.
- If necessary, contact your local authority for

disposal information.

BATTERY DISPOSAL

- The battery should be taken to an Approved Service Centre or your local Recycling Station.
- **Do NOT dispose of used battery with household waste**
- **Do NOT dispose of battery to water.**
- **Lead/Acid batteries can be harmful and should be disposed of through the recognised recycling facility in accordance with European Regulation**
- **Do NOT incinerate**

Fault Finding Hints

Lawnmower will not start

1. Is the correct Starting procedure being followed? See 'To Start your Lawnmower'.
2. Is the safety key correctly located?
3. Is the battery flat? - Charge the battery - See 'Battery Charging'.
4. Has the Safety Key fuse blown? Replace with a new one.
5. Has the Overload Cutout operated? See 'Automatic Overload Cutout'.

If the lawnmower will still not start - remove the safety key.

Consult your local Approved Service Centre.

Poor Grass Collection

1. Clean the outside of the air intakes, the discharge chute and the underside of the deck.
2. Raise the height of cut - See 'Cutting Height Adjustment'.

If poor collection persists - remove the safety key. Consult your local Approved Service Centre.

Excessive Vibration

1. Check that the blade is fitted correctly?
2. If the blade is damaged or worn, replace it with a new one.

If vibration persists, immediately - remove the safety key.

Consult your local Approved Service Centre.

Lawnmower becomes heavy to push

1. In long grass or uneven ground, the height of cut should be raised to a higher position. See 'Cutting Height Adjustment'.
2. Check that the wheels can rotate freely.

If problem persists - remove the safety key. Consult your local Approved Service Centre.

Lack of Motor Power, Overheating or Cutting Out

1. Is the battery flat? - Charge the battery - See 'Battery Charging'.
2. Clean grass clippings and debris from around the motor and air inlets and the underside of the deck including the chute.
3. Raise the height of cut - See 'Cutting Height Adjustment'.

If the lawnmower still lacks power, is overheating or cutting out - remove the safety key. Consult your local Approved Service Centre.

Insufficient Cutting Time

1. Is the battery fully charged? - See 'Battery Charging'.
2. Raise the height of cut - See 'Cutting Height Adjustment'.
3. Battery needs replacing - See 'Changing the Battery'.

If problem persists - remove the safety key. Consult your local Approved Service Centre.

Service Recommendations

- **Your product is uniquely identified by a silver and black product rating label.**
- **We strongly recommend that your product is serviced at least every twelve months, more often in a professional application.**

Guarantee and Guarantee Policy

If any part is found to be defective due to faulty manufacture within two years of original purchase, Electrolux Outdoor Products, through its Authorised Service Repairers will effect the repair or replacement to the customer free of charge providing:

- (a) The fault is reported directly to the Authorised Repairer.
 - (b) Proof of purchase is provided.
 - (c) The fault is not caused by misuse, neglect or faulty adjustment by the user.
 - (d) The failure has not occurred through fair wear and tear.
 - (e) The machine has not been serviced or repaired, taken apart or tampered with by any person not authorised by Electrolux Outdoor Products .
 - (f) The machine has not been used for hire.
 - (g) The machine is owned by the original purchaser.
 - (h) The machine has not been used outside of the country for which it was specified.
 - (i) The machine has not been used commercially.
- * This guarantee is additional to, and in no way diminishes the customers statutory rights.

Failures due to the following are not covered, therefore it is important that you read the instructions contained in this Operator's Manual and understand

how to operate and maintain your machine:

Failures not covered by guarantee

- * Replacing worn or damaged blades.
- * Failures as a result of not reporting an initial fault.
- * Failures as a result of sudden impact.
- * Failures as a result of not using the product in accordance with the instructions and recommendations contained in this Operator's Manual.
- * Machines used for hire are not covered by this guarantee.
- * The following items listed are considered as wearing parts and their life is dependent on regular maintenance and are, therefore not normally subject to a valid warranty claim: Blades.

* Caution!

Electrolux Outdoor Products does not accept liability under the warranty for defects caused in whole or part, directly or indirectly by the fitting of replacement parts or additional parts that are not either manufactured or approved by Electrolux Outdoor Products, or by the machine having been modified in any way

BELGIQUE/BELGIË	Flymo Belgique/België Tel: 02 363 0311, Fax: 02 363 0391
ČESKÁ REPUBLIKA	Electrolux, spol. s.r.o., oz Electrolux Outdoor Products, Dobronická 635, 148 25 Praha 4 Tel: 02/6111 2408-9, Info-linka: 0800/110 220 Internet: www.partner-flymo.cz E-mail: info@husqvarna.cz
DANMARK	Electrolux Outdoor Products, Flymo/Partner A/S, Lundtoftegårdsvej 93A, DK 2800 Kgs.Lyngby Tel: 45 877577, www.flymo-partner.dk
DEUTSCHLAND	Flymo Deutschland Tel: 097 21 7640, Fax:097 21 764202
ESTONIA	Electrolux Estonia Ltd (Electrolux Eesti AS) Tel: (372) 6650010
FRANCE	Flymo France SNC Tel 01 46 67 8141, Fax 01 43 34 2491
FINLAND SUOMI	Flymo Finland Suomi Tel: 00 39611, Fax: 00 39 612632
ITALIA	McCulloch Italiana s.r.l. - Via Como 72, 23868 Valmadrera (LECCO) - ITALIA Tel: 800 017829, Fax: 0341 581671
IRELAND	Flymo Ireland Tel: 01 4565222, Fax: 01 4568551
MAGYARORSZÁG	Electrolux Lehel Kft Tel: 00 36 1 251 41 47
NORGE	Flymo/Partner, div. av Electrolux Motor a.s. Tel: 69 10 47 90
NEDERLAND	Flymo Nederland Tel: 0172-468322, Fax: 0172-468219
ÖSTERREICH	HUSQVARNA Zentralwerkstätte, Industriezeile 36, 4020 LINZ, Tel: 0732 770101-60, Fax: 0732 795922
POLSKA	Electrolux Poland Sp. z.o.o. Husqvarna, 01-612 Warszawa Myslowicka 10/2 Tel:- (22) 8332949
SLOVENIJA	SKANTEH d.o.o. Tel:- (061) 133 70 68, Fax:-(061) 133 70 68
SLOVENSKA	Electrolux Slovakia s.r.o., Borova Sihat 211, 033 01 Lipt. Hradok Tel: 044 522 14 19, Fax: 044 522 14 18, www.flymo-partner.sk
SCHWEIZ/SUISSE/SUIZZERA	Flymo Schweiz/Suisse/Suizzera Tel 062 889 93 50 / 889 94 25, Fax 062 889 93 60 / 889 94 35
SVERIGE	Electrolux Outdoor Products, Sverige Tel: 036 – 14 67 00, Fax: 036 – 14 60 70
UNITED KINGDOM	Electrolux Outdoor Products United Kingdom Tel: 01325 300303, Fax: 01325 310339

Electrolux Outdoor Products
Aycliffe Industrial Park
NEWTON AYCLIFFE
Co.Durham DL5 6UP
ENGLAND

Telephone - (00) 44 1325 300303 Fax - (00) 44 1325 310339

UK Telephone - 01325 300303 Fax - 01325 310339

Our policy of continuous improvement means that the specification of products may be altered from time to time without prior notice. Electrolux Outdoor Products manufacture products for a number of well known brands under various registered patents, designs and trademarks in several countries.

© Electrolux Outdoor Products Ltd. Registered Office, Electrolux Works, Oakley Road, Luton LU4 9QQ
Registered number 974979 England

 ***The Electrolux Group. The world's No.1 choice.***

The Electrolux Group is the world's largest producer of powered appliances for kitchen, cleaning and outdoor use. More than 55 million Electrolux Group products (such as refrigerators, cookers, washing machines, vacuum cleaners, chain saws and lawn mowers) are sold each year to a value of approx. USD 14 billion in more than 150 countries around the world.



5118740-05