

- D** **Gebrauchsanweisung**
UVC-Filter-Set
-
- GB** **Operating Instructions**
Filter Set UVC
-
- F** **Mode d'emploi**
Kit de filtrage UV-C
-
- NL** **Gebruiksaanwijzing**
UVC-filterset
-
- S** **Bruksanvisning**
Filterset UVC
-
- I** **Istruzioni per l'uso**
Set filtro UVC
-
- E** **Manual de instrucciones**
Kit de filtrado UVC
-
- P** **Instruções de utilização**
Conjunto de filtragem UVC
-
- DK** **Brugsanvisning**
Filtersæt UVC

D

GB

F

NL

S

I

E

P

DK

GARDENA Filter Set 5000 UVC

Welcome to GARDENA aquamation...



Please read these operating instructions carefully and follow the instructions. Use these instructions to get to know the UVC Filter Set, using it correctly and the safety instructions.



For safety reasons, children and young people under 16 years of age and people who are not acquainted with these operating instructions should not use this UVC Filter Set.

→ Please keep these operating instructions in a safe place.

Contents

1. Range of Uses for Your GARDENA UVC Filter Set	10
2. For Your Safety	10
3. Mode of Operation of the Filter	12
4. Assembly	12
5. Initial Operation	13
6. Maintenance	13
7. Trouble-Shooting	14
8. Putting out of Operation	16
9. Technical Data	16
10. Service	16

1. Range of Uses for Your GARDENA UVC Filter Set

Purpose

The GARDENA UVC Filter Set is intended for domestic use in your garden where it should only be used alongside your garden pond for cleaning ponds up to 5 m³ in size.

Please note



The GARDENA UVC Filter Set is not suitable for industrial use or in combination with chemicals, food, easily combustible and explosive substances. It is not intended for operating watering equipment and systems.

2. For Your Safety

→ Comply with the safety instructions on the UVC unit.



Warning!
→ Read the operating instructions before using the equipment for the first time!



Caution!
Protect eyes from flash.
Caution!
Ultraviolet radiation.

This radiation is harmful to eyes and skin.
→ Never operate the lamp without its casing!

The maximum permissible operating pressure (P_{max}) is 0.2 bar.

Mains connection

The pump and the UVC unit must be operated via a residual-current device (FI-switch) with a nominal fault current ≤ 30 mA (DIN VDE 0100-702 and 0100-738).

→ Please ask your electrician for his advice.

The pump must be placed on solid, even ground.

Mains power cables should not have a smaller cross-section than a rubber sheathed cable of the designation H05 RNF.

Extension cables must meet the requirements of DIN VDE 0620.

The data on the type plates of the pump and the UVC-unit must match the data for the power circuit.

The main power cable of the pump and the UVC cannot be replaced. If the main power cable is damaged the unit must be scrapped.

Do not use extension leads, connection leads or adapters without a protective contact.

For Austria

In Austria power cables should correspond to ÖVE-EM 42, T 2 (2000)/1979 § 22 according to § 2022.1. According to this standard units used in swimming pools and ponds should only be operated via an isolating transformer.

→ Please contact your electrician.

For Switzerland

In Switzerland mobile appliances which are used outdoors, must be connected via a residual-current device.

Visual inspection and notes

→ Inspect the equipment before use to ensure that the pump and the UVC unit, especially the power cable and plug, are undamaged.

Do not use a damaged pump or a damaged UVC unit.

Do not use the light if the connection lead, glass tube or the housing of the UVC unit appear to be defective.

If the pump or UVC unit are damaged, please have them checked by our GARDENA Service Centre or an authorised electrician.

The pump must not be operated when there are people in the water.

Swimming pools and garden ponds should be designed according to international and national design regulations.

→ Please consult a professional electrician.

Do not carry the pump or the UVC unit by the cable and do not use the cable to pull the plug out of the socket.

Please protect the cable from heat, oil and sharp edges. Make sure that connection points remain dry.

The temperature of the liquid used must not be below 4 °C or above 35 °C.

Sand and other abrasive substances in the liquid cause increased wear and reduce the output of the pump.

Putting your pump out of operation

Always unplug the equipment when dismantling the set, when it is not in use and before maintenance.

→ Always disconnect the UVC unit and the pump from the mains before undertaking any work on them.

→ Please follow the safety and assembly instructions in these operating instructions.

Safety switch

If the UVC light overheats, it is switched off by the built-in thermal protection switch. The UVC light switches itself on again automatically when it has cooled down sufficiently.

Due to the integrated safety switch the lamp only comes on when the UVC unit is properly installed.

Positioning the filter

→ Place the filter next to the garden pond and ensure it is stable.

The filter must be positioned higher than the surface of the pond.

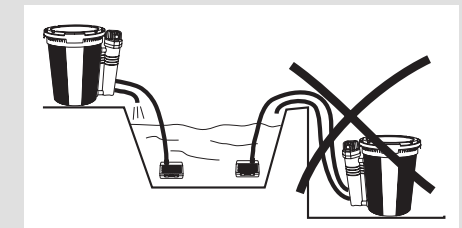

Never operate the UVC unit without water throughput.

3. Mode of Operation of the Filter

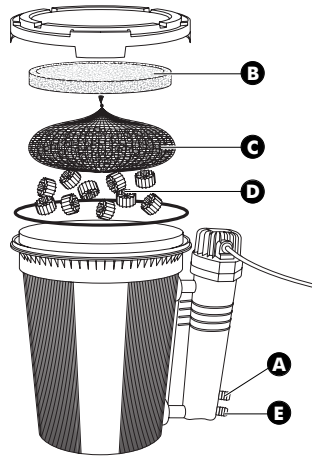

- A Water intake (UVC unit)**
Connection for the hose from the pump in the pond.
- B Mechanical filtering**
Foam filter mat for filtering out coarse dirt particles.
- C Biological filtering**
The pollutants and surplus nutrients are bonded to the filter pellets and broken down.
- D Bio-surface filters**
The basis for biological water treatment by building up micro-organisms.
- E Water outlet (UVC unit)**
Connection for the hose to return the purified water to the pond.

4. Assembly

Assemble the filter set:

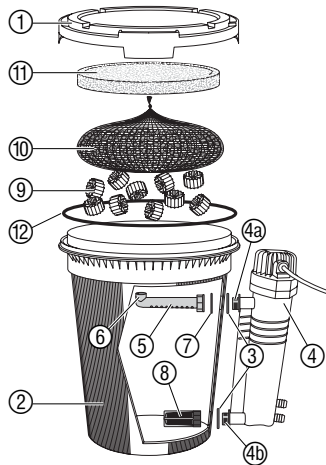

1. Take the filter cover ① off the filter container ② and remove the contents.
2. Assemble the UVC bulb (see 7. **Trouble-Shooting** “*Changing the bulb*”).
3. Place sealing rings ③ on the UVC unit ④ and push the UVC unit ④ into the filter container ② from outside.
4. Screw filter ⑧ on to the water outlet ④b of the UVC unit ④ from inside.
5. Screw the jet pipe ⑤ from inside on to the water intake ④a of the UVC unit ④.

The outlet ⑥ of the jet pipe ⑤ must face the cover. Use the plastic ring ⑦ if necessary.
6. Place bio-surface filters in the net ⑨ into the filter container.
7. Place the filter pellets in the net supplied ⑩ and spread the net over the bio-surface filters ⑨.
8. Place the foam filter mat ⑪ in the filter container in such a way that the foam filter mat covers the net ⑩ completely. *The jet pipe ⑤ is now above the foam filter mat ⑪.*
9. Put the O-seal ⑫ on the top margin of the filter container.
10. Push the filter cover ① on to the filter container ②.

Assemble the pump:

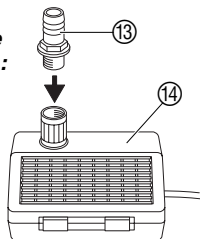

Screw the connection piece ⑬ on to the pump ⑭.

5. Initial Operation

Starting up the filter set:

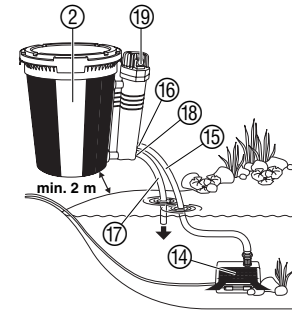

1. Place the filter container ② above the surface of the pond in a stable position alongside the garden pond but at least 2 m away from it.
2. Decide on the length of the supply hose ⑮ and the drain hose ⑰ and cut to size.
3. Connect the filter supply hose ⑮ to the pump ⑭.
4. Set up the pump ⑭ in a stable position in the garden pond so that the pump is completely covered with water.
5. Connect the supply hose ⑮ of the pump ⑭ to the water intake ⑯ (max. 50 cm above the surface of the water) of the UVC unit.
6. Connect the drain hose ⑰ to the water discharge connection ⑰ (at least 5 cm above the surface of the water) of the UVC unit and route it into the pond.
7. Plug the mains plug of the pump into a 230 V AC socket.
Warning: The pump will start immediately!
8. Plug the mains plug of the UVC unit into a 230 V AC socket.
The UVC warning light ⑲ goes on.

Do not allow the pump to run without water:

Do not allow the pump to run without water because dry-running leads to an undesirable build up of heat and will destroy the pump.

6. Maintenance

Cleaning the filter:

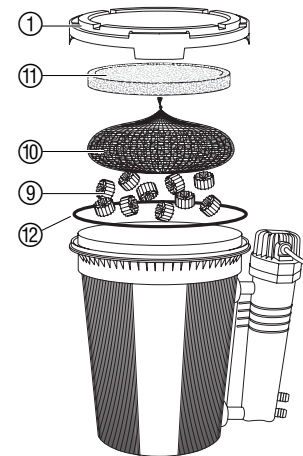

The GARDENA filter is largely maintenance-free. However, it must be cleaned when necessary.

1. Unplug the pump and the UVC unit from the mains.
2. Remove the filter cover ① and the O-seal ⑫.
3. Remove the foam filter mat ⑪ and remove coarse dirt under flowing water.
4. Remove the net containing the filter pellets ⑩ and place it in a solution of cooking salt (20 g salt/litre) for approximately 24 hours.
5. Then rinse the net ⑩ with fresh lukewarm water.
6. Place the bio-surface filter ⑨ in clean water for approximately 24 hours.
Do not clean under running water because this will destroy the micro-organisms.
7. Empty the filter container completely and clean under running water.
8. Reassemble filter in reverse order.
9. Start the filter up again (see 5. **Putting into Operation** “*Starting up the filter set*”).

We recommend cleaning the filter pellets approximately every 6 months or replacing them to guarantee that the filter pellets are still able to work properly.

Please contact GARDENA Service about replacing the filter pellets.

Cleaning the UVC unit:

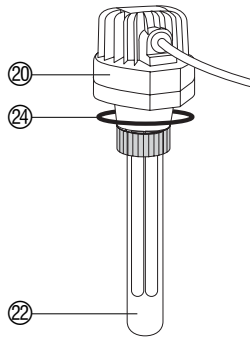

1. Unplug the mains plug of the UVC unit and pump.
2. Turn the cap 20 of the UVC unit 1 and remove carefully 2 (bayonet fitting).
3. Clean the glass tube 22 (using liquid glass cleaner, for example).
4. Fit the UVC unit again in reverse order.

When assembling, ensure that the O-ring 24 is inserted correctly in the cover 20 and that the arrow markings 25 are aligned opposite one another.

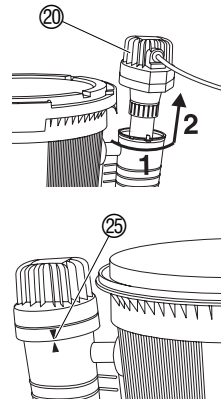

Cleaning the pump:

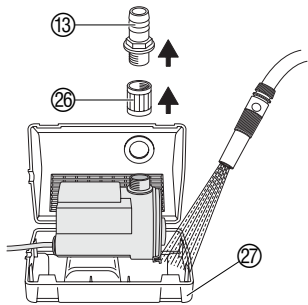

Cleaning the pump filter housing:

The water intake slots on the water feature pump must be free from dirt.

1. Unplug the pump and the UVC unit from the mains.
2. Remove the pump from the pond.
3. Unscrew threaded sleeve 26 and connection piece 13.
4. Open up the pump filter housing 27 and spray clean with a jet of water.
5. Clean the water intake slots of the filter housing 27 with a brush.

Note: Do not use any hard objects or powerful detergents for cleaning the set!

Remove dirt deposits in the pump:

1. Unplug the pump and the UVC unit from the mains.
2. Remove the pump from the pond.
3. Unscrew threaded sleeve 26.
4. Open up pump filter housing 27 and remove the pump.
5. Open the snap hook 28 and take the pump cover 29 off the motor housing 30.
6. Draw the impeller unit 31 out of the motor housing 30.
7. Remove any dirt deposits from pump components.
8. Replace the impeller unit 31 in the motor housing 30.
9. Press the pump cover 29 into the motor housing 30 until the connection is heard to snap into place.

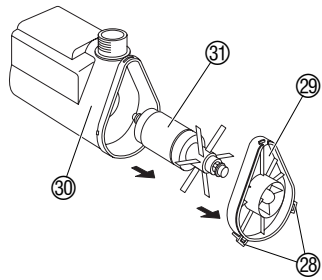

7. Trouble-Shooting

Changing the bulb:

The UVC bulb should be replaced after approximately 8,000 operating hours since the UVC performance decreases dramatically after this time.

Only bulbs of type 9 W TC-S (UV-C) should be used (e. g. Radium: Puritec NSE 9-270, Philips: TUV PL-S 9W or Sylvania: G9 LYNX-S GERMICIDAL). The UVC lamp can be ordered as a replacement part from GARDENA Service.

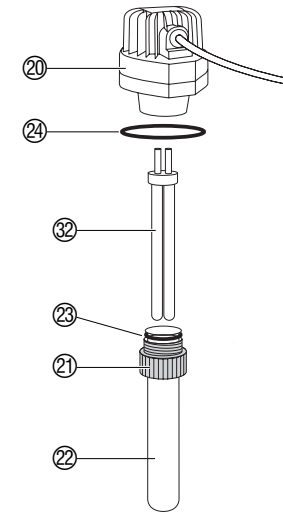

1. Unplug the mains plug of the UVC unit and pump.
2. Turn the cap 20 of the UVC unit 1 and remove carefully 2 (bayonet fitting).
3. Carefully unscrew the ring 21.
4. Pull off the glass tube 22. (It may be relatively difficult to remove the glass tube due to mineral deposits.)
5. Take out the bulb 32 and replace it with a new one.
6. Reassemble the UVC unit in reverse order.

When assembling, ensure that the O-ring 24 fits properly on the glass tube 22, that the O-ring 24 is inserted correctly in the cover 20 and that the arrow markings 25 are aligned opposite one another.

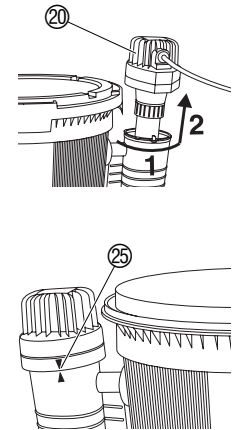

Due to the integrated safety switch the lamp only comes on when the UVC unit is properly installed.

Fault	Possible Cause	Remedy
The water is not clear.	The pond is extremely dirty and rich in nutrients.	<ol style="list-style-type: none"> 1. Check nitrate concentration (e. g. with the GARDENA Pond Test Set, Art. No. 7920). 2. If necessary, change the water and clean the pond.
	Filter pellets dirty.	→ Clean filter pellets (see 6. Maintenance „Cleaning the filter“).
	Too many fish and creatures in the pond.	→ Add up the estimated length of the fish. There should only be “80 cm fish” per m ³ water in the pond.
Pump does not work.	The glass tube of the UVC unit is dirty.	→ Clean UVC unit (see 6. Maintenance).
	Electrical connections defective.	→ Check electrical connections.
The UVC pilot light is not on.	Impeller unit blocked.	→ Remove dirt deposits in the pump (see 6. Maintenance).
	Bulb defective.	→ Change bulb.
	Electrical connections defective.	→ Check electrical connections.
	The cap 20 has not snapped properly into place.	→ The cap is fitted correctly when the two arrow markings 25 are in alignment with one another.

If any other faults arise, please contact GARDENA Service.

8. Putting out of Operation

Over-wintering:



1. Before frosts commence, remove the pump from the pond, take the hose off the pump and empty the filter completely.
2. Clean filter, UVC unit and pump thoroughly and dry it (see **6. Maintenance**).
3. Store filter, UVC unit and pump in a frost-free place.
4. Store the pump in a container filled with water so that the pump does not dry out.
The mains plug should not be soaked during the process.

Store out of reach of children.

9. Technical Data

	UVC unit (Art. 7930)	Pump (Art. 7919)
Rated power	9 W	14 W
Max. flow of the pump		900 l/h
Max. delivery head		1.5 m
Max. submersion depth		1.0 m
Power cable	3 m H05 RNF	10 m H05 RNF
Bulb	type 9 W TC-S (UV-C) (e.g. Radium: Puritec NSE 9-270, Philips: TUV PL-S 9W or Sylvania: G9 LYNX-S GERMICIDAL)	
Mains voltage / Frequency	230 V / 50 Hz	230 V / 50 Hz
Fitting		G 1/2
Max. media temperature	35 °C	35 °C
Noise level $L_{WA}^{1)}$		48 dB (A)

1) Measuring method according to EN 60335-1

10. Service

Warranty

GARDENA guarantees this product for 2 years (starting from the date of purchase). This guarantee covers all serious defects of the unit that can be proved to be material or manufacturing faults. Under warranty we will either replace the unit or repair it free of charge if the following conditions apply:

- The unit must have been handled properly and in keeping with the requirements of the operating instructions.
- Neither the purchaser or a non-authorized third party have attempted to repair the unit.

The bulb (type 9 W TC-S (UV-C)), the impeller unit and the filter pellets are wearing parts and are not covered by the guarantee. This manufacturer's guarantee does not affect the user's existing warranty claims against the dealer/seller.

If you have any problems with your pump, please contact our Customer Service or return the defective unit together with a short description of the problem directly to one of the GARDENA Service Centres listed on the back of this leaflet.

D Produkthftung	Wir weisen ausdrücklicly darauf hin, dass wir nach dem Produkthftungsgesetz nicht für durch unsere Geräte hervorgerufene Schäden einzustehen haben, sofern diese durch unsachgemäÙe Reparatur verursacht oder bei einem Teileaustausch nicht unsere Original GARDENA Teile oder von uns freigegebene Teile verwendet werden und die Reparatur nicht vom GARDENA Service oder dem autorisierten Fachmann durchgeführt wird. Entsprechendes gilt für Ergänzungssteile und Zubehör.
GB Product Liability	We expressly point out that, in accordance with the product liability law, we are not liable for any damage caused by our units if it is due to improper repair or if parts exchanged are not original GARDENA parts or parts approved by us, and, if the repairs were not carried out by a GARDENA Service Centre or an authorised specialist. The same applies to spare parts and accessories.
F Responsabilit�	Nous vous signalons express�ment que GARDENA n'est pas responsable des dommages caus�s par ses appareils, dans la mesure o� ces dommages seraient caus�s suite � une r�paration non conforme, dans la mesure o�, lors d'un �change de pi�ces, les pi�ces d'origine GARDENA n'auraient pas �t� utilis�es, ou si la r�paration n'a pas �t� effectu�e par le Service Apr�s-Vente GARDENA ou l'un des Centres SAV agr�es GARDENA. Ceci est �galement valable pour tout ajout de pi�ces et d'accessoires autres que ceux pr�conis�s par GARDENA.
NL Productaansprakelijkeid	Wij wijzen er nadrukkelijk op, dat wij op grond van de wet aansprakelijkeid voor producten niet aansprakelijk zijn voor schade ontstaan door onze apparaten, indien deze door onvakkundige reparatie veroorzaakt zijn, of er bij het uitwisselen van onderdelen geen gebruik gemaakt werd van onze originele GARDENA onderdelen of door ons vrijgegeven onderdelen en de reparatie niet door de GARDENA technische dienst of de bevoegde vakman uitgevoerd werd. Ditzelfde geldt voor extra-onderdelen en accessoires.
S Produktansvar	Tillverkaren �r inte ansvarig f�r skada som orsakats av produkten om skadan beror p� att produkten har reparerats felaktigt eller om, vid reparation eller utbyte, andra �n Original GARDENA reservdelar har anv�nts. Samma sak g�ller f�r kompletteringsdelar och tillbeh�r.
I Responsabilit� del prodotto	Si rende espressamente noto che, conformemente alla legislazione sulla responsabilit� del prodotto, non si risponde di danni causati da nostri articoli se originati da riparazioni eseguite non correttamente o da sostituzioni di parti effettuate con materiale non originale GARDENA o comunque da noi non approvato e, in ogni caso, qualora l'intervento non venga eseguito da un centro assistenza GARDENA o da personale specializzato autorizzato. Lo stesso vale per le parti complementari e gli accessori.
E Responsabilidad de productos	Advertimos que conforme a la ley de responsabilidad de productos no nos responsabilizamos de da�os causados por nuestros aparatos, siempre y cuando dichos da�os hayan sido originados por arreglos o reparaciones indebidas, por recambios con piezas que no sean piezas originales GARDENA o bien piezas autorizadas por nosotros, as� como en aquellos casos en que la reparaci�n no haya sido efectuada por un Servicio T�cnico GARDENA o por un t�cnico autorizado. Lo mismo es aplicable para las piezas complementarias y accesorios.
P Responsabilidade sobre o produto	Queremos salientar que segundo a lei da responsabilidade do fabricante, n�s n�o nos responsabilizaremos por danos causados pelo nosso equipamento, quando estes ocorram em decorr�ncia de repara�es inadequadas ou da substitui�o de pe�as por pe�as n�o originais da GARDENA, ou pe�as n�o autorizadas. A responsabilidade tornar-se-� nula tamb�m depois de repara�es realizadas por oficinas n�o autorizadas pela GARDENA. Esta repara�o valer� tamb�m para pe�as adicionais e acess�rios.
DK Produktansvar	Vi g�r udtrykkeligt opm�rksom p� at i henhold til produktansvarsloven er vi ikke ansvarlige for skader for�rsaget af vores udstyr, hvis det skyldes uautoriserede reparationer eller hvis dele er skiftet ud og der ikke er anvendt originale GARDENA dele eller dele godkendt af os, eller hvis reparationerne ikke er udf�rt af GARDENA-service eller en autoriseret fagmand. Det samme g�lder for ekstra udstyr og tilbeh�r.

D EU-Konformit�tserkl�rung Maschinenverordnung (9. GSGVO) / EMVG / Niedersp. RL	Der Unterzeichnete GARDENA International GmbH, Hans-Lorenser-Str. 40, D-89079 Ulm, best�tigt, dass die nachfolgend bezeichneten Ger�te in der von uns in Verkehr gebrachten Ausf�hrung die Anforderungen der harmonisierten EU-Richtlinien, EU-Sicherheitsstandards und produktspezifischen Standards erf�llen. Bei einer nicht mit uns abgestimmten �nderung der Ger�te verlir diese Erkl�rung ihre G�ltigkeit.	Bezeichnung des Ger�tes: Description of the unit: D�signation du mat�riel: Omschrijving van het apparaat: Produktbeskrivning: Descrizione del prodotto: Descripci�n de la mercanca: Descri�o do aparelho: Beskrivelse af enhederne:	UVC-Filter-Set Filter Set UVC Kit de filtrage UVC UVC filter set Filterset UVC Set filtro UVC Kit de filtrado UVC Conjunto de filtragem UVC Filters�t UVC
GB EU Certificate of Conformity	The undersigned GARDENA International GmbH, Hans-Lorenser-Str. 40, D-89079 Ulm, hereby certifies that, when leaving our factory, the units indicated below are in accordance with the harmonised EU guidelines, EU standards of safety and product specific standards. This certificate becomes void if the units are modified without our approval.	Typ: Type: Type: Typ: Typ: Modello: Tipo: Tipo: Type:	Art.-Nr.: Art. No.: R�f�rence: Art. nr.: Art.nr.: Art.: Art. N�: Art. N�: Varenr.:
F Certificat de conformit� aux directives europ�ennes	Le constructeur, soussign� : GARDENA International GmbH, Hans-Lorenser-Str. 40, D-89079 Ulm, d�clare qu'� la sortie de ses usines le mat�riel neuf d�sign� ci-dessous �tait conforme aux prescriptions des directives europ�ennes �nonc�es ci-apr�s et conforme aux r�gles de s�curit� et autres r�gles qui lui sont applicables dans le cadre de l'Union europ�enne. Toute modification port�e sur ce produit sans l'accord express de GARDENA supprime la validit� de ce certificat.	EU-Richtlinien: EU directives: Directives europ�ennes: EU-richtlijnen: EU direktiv: Direttiva UE: Normativa UE: Directrizes da UE: EU Retningslinier:	 73/23/EC 89/336/EC 93/68/EC
NL EU-overeenstemmingsverklaring	Ondergetekende GARDENA International GmbH, Hans-Lorenser-Str. 40, D-89079 Ulm, bevestigt, dat het volgende genoemde apparaat in de door ons in de handel gebrachte uitvoering voldoet aan de eis van, en in overeenstemming is met de EU-richtlijnen, de EU-veiligheidsstandaard en de voor het product specifieke standaard. Bij een niet met ons afgestemde verandering aan het apparaat verlir deze verklaring haar geldigheid.	Anbringingsjahr der CE-Kennzeichnung: Year of CE marking: Date d'apposition du marquage CE: Installatiejaar van de CE-aanduiding: CE-M�rkings�r: Anno di rilascio della certificazione CE: Colocaci�n del distintivo CE: Ano de marca�o pela CE: CE-M�rkings�r:	 2002
S EU Tillverkarintyg	Undertecknad firma GARDENA Kress + Kastner GmbH, Hans-Lorenser-Str. 40, D-89079 Ulm, intygar h�rmed att nedan n�mnda produkter �verensst�mmer med EU:s direktiv, EU:s s�kerhetsstandard och produktspecifikation. Detta intyg upph�r att g�lla om produkten �ndras utan v�rt tillst�nd.	 Thomas Heini	
I Dichiarazione di conformit� alle norme UE	La sottoscritta GARDENA International GmbH, Hans-Lorenser-Str. 40, D-89079 Ulm, certifica che il prodotto qui di seguito indicato, nei modelli da noi commercializzati, � conforme alle direttive armonizzate UE nonch� agli standard di sicurezza e agli standard specifici di prodotto. Qualunque modifica apportata al prodotto senza nostra specifica autorizzazione invalida la presente dichiarazione.	Ulm, den 20.12.2002 Ulm, 20.12.2002 Fait � Ulm, le 20.12.2002 Ulm, 20-12-2002 Ulm, 2002.12.20. Ulm, 20.12.2002 Ulm, 20.12.2002 Ulm, 20.12.2002 Ulm, 20.12.2002	Technische Leitung Technical Dept. Manager Direction technique Hoofd technische dienst Technical Director Direzione Tecnica Direcci�n T�cnica Director T�cnico Teknik direkt�r
E Declaraci�n de conformidad de la UE	El que suscribe GARDENA International GmbH, Hans-Lorenser-Str. 40, D-89079 Ulm, declara que la presente mercanca, objeto de la presente declaraci�n, cumple con todas las normas de la UE, en lo que a normas t�cnicas, de homologaci�n y de seguridad se refiere. En caso de realizar cualquier modificaci�n en la presente mercanca sin nuestra previa autorizaci�n, esta declaraci�n pierde su validez.		
P Certificado de conformidade da UE	Os abaixo mencionados GARDENA International GmbH, Hans-Lorenser-Str. 40 D-89079 Ulm, por este meio certificam que ao sair da f�brica o aparelho abaixo mencionado est� de acordo com as directrizes harmonizadas da UE, padr�es de seguran�a e de produtos espec�ficos. Este certificado ficar� nulo se a unidade for modificada sem a nossa aprova�o.		
DK EU Overensstemmelse certifikat	Undertegnede GARDENA International GmbH, Hans-Lorenser-Str. 40, D-89079 Ulm b�kr�fter hermed, at enheder listet herunder, ved afsendelse fra fabrikken, er i overensstemmelse med harmoniserede EU retningslinier, EU sikkerhedsstandarder og produktspecifikationsstandarder. Dette certifikat tr�der ud af kraft hvis enhederne er �ndret uden vor godkendelse.		

Deutschland

GARDENA International GmbH
Service Center
Hans-Lorenser-Str. 40
89079 Ulm
Produktfragen: (07 31) 490-123
Reparaturen: (07 31) 490-290

Argentina

Argensem S.A.
Calle Colonia Japonesa s/n
(1625) Loma Verde
Escobar, Buenos Aires

Australia

NYLEX Consumer Division
76-88 Mills Road
P.O. Box 722
Braeside 3195
Melbourne, Victoria

Austria

GARDENA Österreich Ges. m.b.H.
Stettnerweg 11-15
2100 Korneuburg

Belgium

MARKT (Belgium) NV/SA
Sterrebeekstraat 163
1930 Zaventem

Brazil

RGS Comercial Ltda
Av. Marginal do Rio Pinheiros, 5200
Edifício Montreal - Bloco e - Terreo
05693-000 - Sao Paulo - SP

Bulgaria / България

ДЕНЕКС ООД
Бул. "Г.М.Димитров" 16 ет.4
София 1797

Canada

GARDENA Canada Ltd.
100 Summerlea Road
Brampton, Ontario
Canada L6T 4X3

Chile

Antonio Martinic Y CIA. LTDA.
Gilberto Fuenzalida 185 Loc.
Las Condes - Santiago de Chile

Costa Rica

Compania Exim
Euroiberoamericana S.A.
Av. 12 bis Calle 16 y 18,
Bodegas Keith y Ramirez
San José

Cyprus

FARMOKIPIKI LTD
P.O. Box 7098
74, Digeni Akrita Ave.
1641 Nicosia

Czech Republic

GARDENA spol. s.r.o.
Řípská 20 a, č.p. 1153
62700 Brno

Denmark

GARDENA Danmark A/S
Naverland 8
2600 Glostrup

Finland

Habitec Oy
Martinkyläntie 52
01720 Vantaa

France

GARDENA France
Service Après-Vente
BP 50080
95948 ROISSY CDG Cedex

Great Britain

GARDENA UK Ltd.
27-28 Brenkley Way
Bleazard Business Park
Seaton Burn
Newcastle upon Tyne NE13 6DS

Greece

Agrokip G. Psomadopoulos & Co.
33 A, Ifestou str. – 194 00
Industrial Area Koropi
Athens

Hungary

GARDENA Magyarország Kft.
Késmárk utca 22
1158 Budapest

Iceland

Heimilistaeki hf
Saetun 8
P.O. Box 5340
125 Reykjavik

Republic of Ireland

Michael McLoughlin & Sons
Hardware Limited
Long Mile Road
Dublin 12

Italy

GARDENA Italia S.p.A.
Via Donizetti 22
20020 Lainate (Mi)

Japan

KAKUDAI Mfg. Co. Ltd.
1-4-4, Itachibori Nishi-ku
Osaka 550

Luxembourg

Magasins Jules Neuberg
Grand Rue 30
Case Postale No. 12
Luxembourg 2010

Netherlands

GARDENA Nederland B.V.
Postbus 50176
1305 AD ALMERE

Neth. Antilles

Jonka Enterprises N.V.
Sta. Rosa Weg 196
P.O. Box 8200
Curaçao

New Zealand

NYLEX New Zealand Limited
Private Bag 94001
South Auckland Mail Centre
10 Offenhauser Drive
East Tamaki, Manukau

Norway

GARDENA Norge A/S
Postboks 214
2013 Skjetten

Poland

GARDENA Polska Sp. z o.o.
Szymanów 9 d
05-532 Baniocha

Portugal

GARDENA Portugal Lda.
Recta da Granja do Marquês
Edif. GARDENA
Algueirão
2725-596 Mem Martins

Russia / Россия

АО АМИДА ТТЦ
ул. Мосфильмовская 66
117330 Москва

Singapore

Hy - Ray Enterprises
Block 1002 Toa Payoh
Industrial Park
#07-1433/1435/1451
Singapore 319074

Slovenia / Croatia

Silk d.o.o. Trgovina
Brodišče 15
1236 Trzin

South Africa

GARDENA South Africa (Pty.) Ltd.
P.O. Box 11534
Vorna Valley 1686

Spain

GARDENA IBÉRICA S.L.U.
C/ Basauri, nº 6
La Florida
28023 Madrid

Sweden

GARDENA Norden AB
Box 9003
20039 Malmö

Switzerland

GARDENA AG
Bitziberg 1
8184 Bachenbülach

Ukraine / Украина

АОЗТ АЛЬЦЕСТ
ул. Гайдара 50
г. Киев 01033

Turkey

GARDENA / Dost Diş Ticaret
Mümesillik A.Ş.
Yeşilbağlar Mah. Başkent
Cad. No. 26
Pendik - İstanbul

USA

GARDENA
3085 Shawnee Drive
Winchester, VA 22604

7930-20.960.02/0041
© GARDENA Manufacturing GmbH
D-89070 Ulm
<http://www.gardena.com>