

Art. 2613

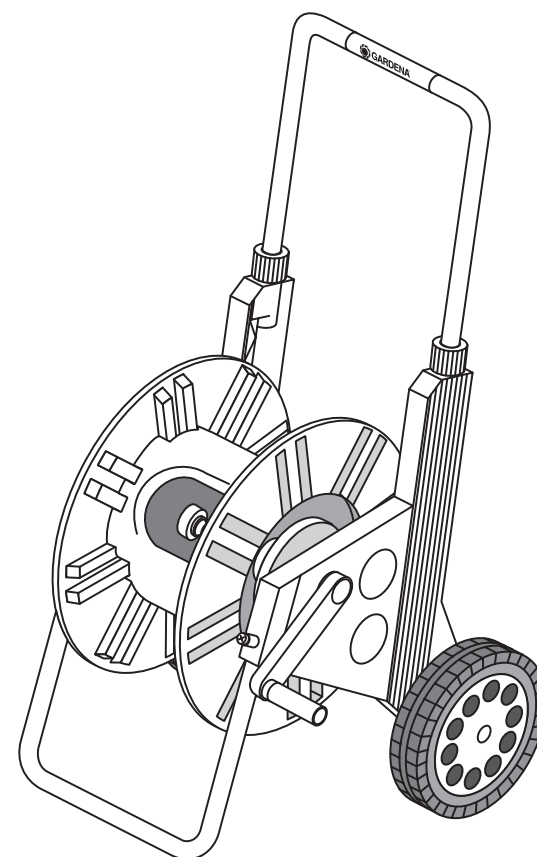

Art. 2631

D	Montageanleitung Schlauchwagen 60/100
GB	Operating Instructions Hose Trolley 60/100
F	Mode d'emploi Dévidoirs sur roues 60/100
NL	Gebruiksaanwijzing Slangenwagen 60/100
S	Bruksanvisning Slangvagn 60/100
I	Istruzioni per il montaggio Carrelli avvolgitubo 60/100
E	Manual de instrucciones Carros portamangueras 60/100
P	Instruções de operação Carros porta-mangueiras 60/100
DK	Brugsanvisning Slangevogn 60/100

- D** Zur Montage benötigen Sie einen Kreuzschlitz-Schraubendreher.
1. Trommel entsprechend der Bildfolge **A** montieren.
 2. Schlauchwagen entsprechend der Bildfolge **B** montieren. Dabei den Schubbügel mit Kraft über den spürbaren Anschlag vollständig einschieben.
 3. Kurbelmontage-Empfehlung **C**: **CR** Rechtshänder, **CL** Linkshänder.
- Vor der Frostperiode den Schlauchwagen frostsicher lagern.

- GB** You will need a Phillips (cross-head) screwdriver to assemble your hose trolley.
1. Assemble drum as shown in diagram sequence **A**.
 2. Assemble hose trolley as shown in diagram sequence **B**. Push in guide handle forcefully over the catch as far as it will go.
 3. Recommended position for crank handle **C**: **CR** for right-handed use, **CL** for left-handed use.
- Store your hose trolley away from frost before the first frost sets in.

- F** Pour le montage vous avez besoin d'un tournevis cruciforme.
1. Monter le tambour suivant les illustrations **A**.
 2. Monter le chariot suivant les illustrations **B** en enfonçant entièrement l'arceau fortement au-delà de la butée.
 3. Recommandation pour le montage de la manivelle **C**: **CR** pour les droitiers, **CL** pour les gauchers.
- Ranger le chariot à l'abri du gel avant la saison froide.

- NL** Voor de montage heeft u een kruiskopschroevendraaier nodig.
1. Trommel in de volgorde van afbeelding **A** monteren.
 2. Slangenwagen in de volgorde op afbeelding **B** monteren. Daarbij de duwbeugel krachtig geheel over de voelbare aanslag duwen.
 3. Aanbeveling krukmontage **C**: **CR** rechtshandigen, **CL** linkshandigen.
- Voor de vorstperiode de slangenwagen vorstvrij opbergen.

- S** För montering behövs en stjärnskruvmejsel.
1. Montera trumman enligt bildserie **A**.
 2. Montera slangförvaringen enligt bildserie **B**. Tryck till handtaget ordentligt över anslaget och tryck in helt.
 3. Rekommendation för veven **C**: **CR** högerhänta, **CL** vänsterhänta
- Lagra slangförvaringen på frostsäker plats.

- I** Per montare il carrello, servirsi di un cacciavite a croce.
1. Montare il tamburo attenendosi alla figura **A**.
 2. Assemblare le altre parti come da fig. **B**. Inserire il manico spingendolo a fondo con forza fino alla battuta.
 3. Montare la manovella (fig. **C**): come da fig. **CR** per i destrimani; come da fig. **CL** per i mancini.
- Prima dell'inverno riporre il carrello avvolgitubo in luogo riparato.

- E** Para el montaje necesita un destornillador para tornillos con ranura en cruz.
1. Montar el tambor como muestra la figura **A**.
 2. Montar el carro como muestra la figura **B**. Introducir la barra de empuje completamente con fuerza hasta el tope.
 3. Recomendación para el montaje de la manivela **C**: **CR** para diestros, **CL** para zurdos.
- Guardar el carro portamangueras en lugar protegido contra las heladas durante el invierno.

- P** Para montagem necessita de uma chave de parafusos Philips.
1. Montar o tambor de acordo com a sequência de imagens **A**.
 2. Montar o carro de mangueira de acordo com a sequência de imagens **B**. Neste processo, inserir o estribo completamente com força para além do encosto notável.
 3. Recomendação da montagem da manivela **C**: **CR** – para pessoas dextrímanos, **CL** – para pessoas canhotos.
- Guardar o carro de mangueira ao abrigo de geadas, antes do início do período de geadas.

- DK** Du skal bruge en stjerneskruetrækker for at samle din slangevogn.
1. Tromlen monteres i henhold til billederne **A**.
 2. Slangevognen monteres i henhold til billederne **B**. Herved skal skydebojlen skubbes fuldstændigt ind med magt via det mærkbare anslag.
 3. Anbefaling for montering af håndsving **C**: **CR** højrehåndet, **CL** venstrehåndet.
- For frostperioden skal slangevognen opbevares på et frostfrit sted.

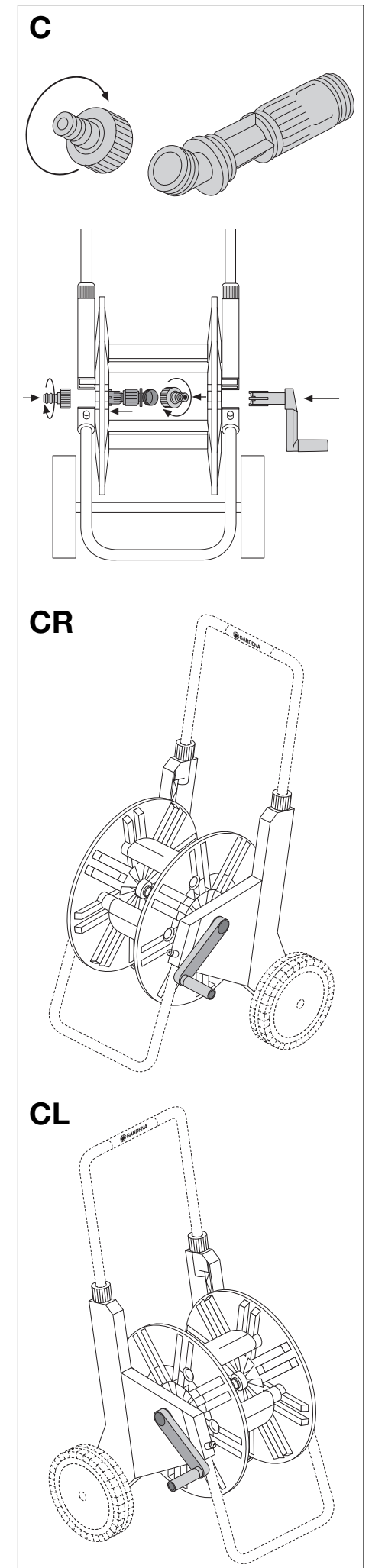
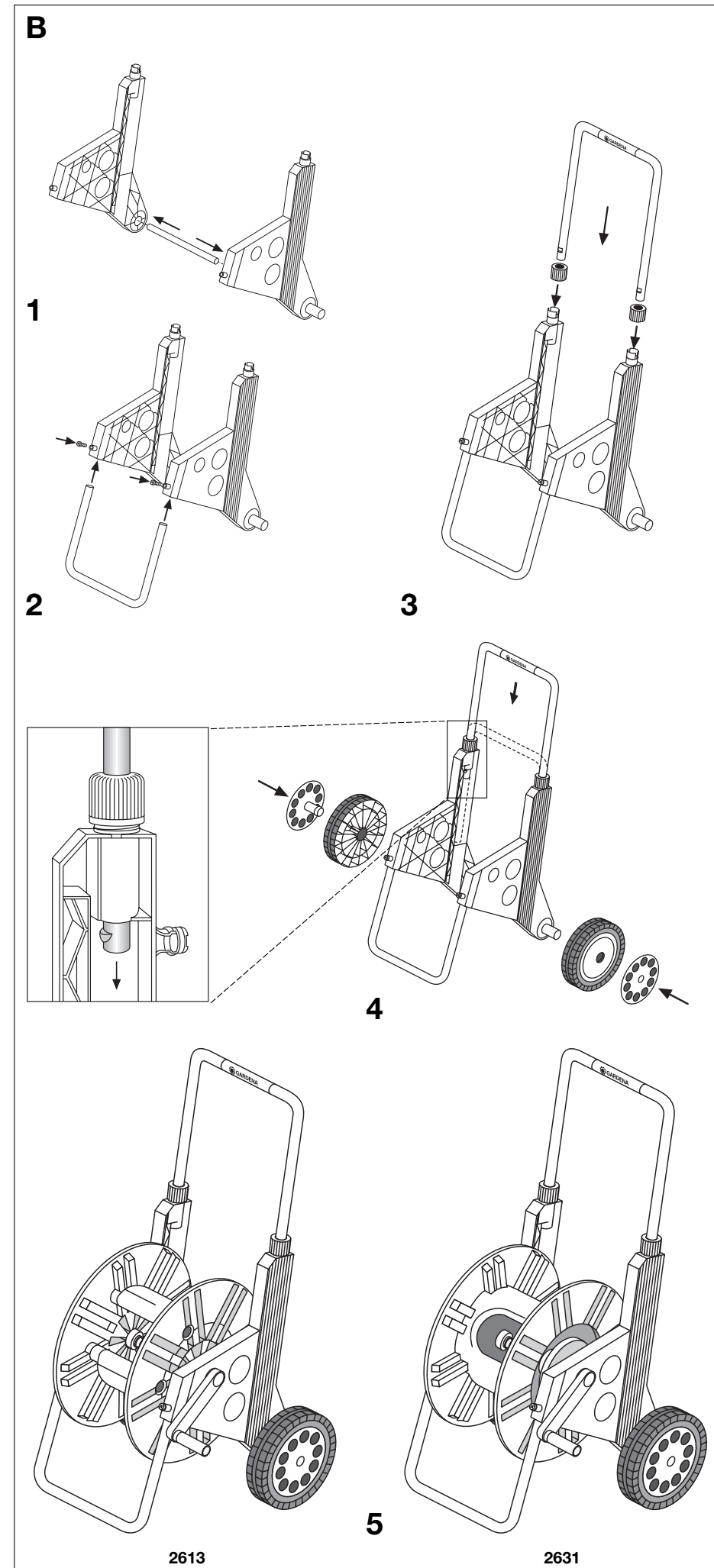
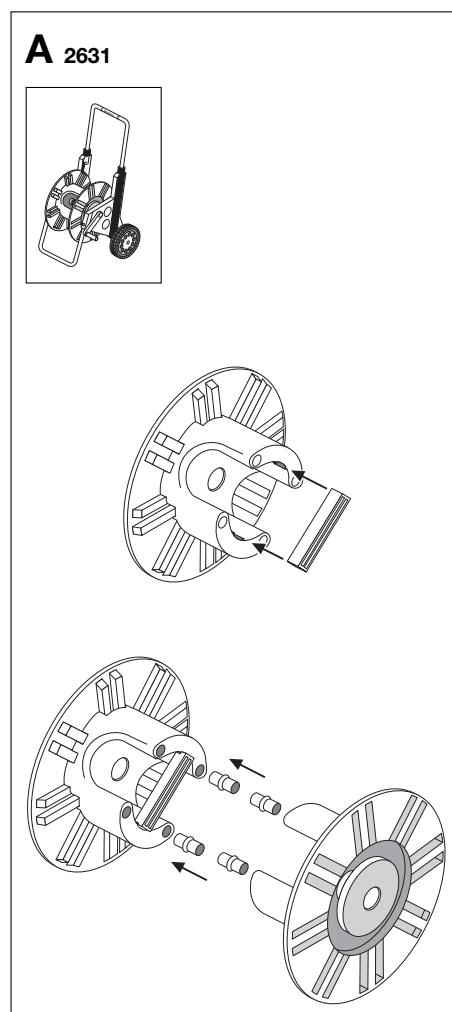
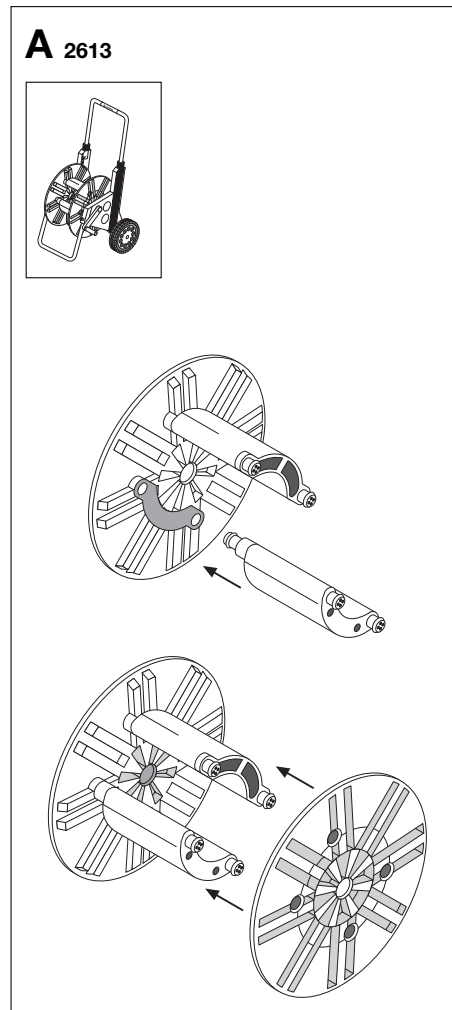

Service

Deutschland / Germany

GARDENA
Manufacturing GmbH
Service Center
Hans-Lorenser-Str. 40
89079 Ulm
Produktfragen:
(+49) 731 490-123
Reparaturen:
(+49) 731 490-290
service@gardena.com

Argentina

Argensem S.A.
Calle Colonia Japonesa s/n
(1625) Loma Verde
Escobar, Buenos Aires
Phone: (+54) 34 88 49 40 40
info@argensem.com.ar

Australia

NYLEX Consumer Products
50 – 70 Stanley Drive
Somerton, Victoria, 3062
Phone: (+61) 3 9303 1439
nylex.spareparts@nylex.com.au

Austria / Österreich

GARDENA Österreich
Ges. m.b.H.
Stettnerweg 11-15
2100 Korneuburg
Tel.: (+43) 22 62 745 45-36
od. -30
kundendienst@gardena.at

Belgium

GARDENA Belgium NV/SA
Sterrebeekstraat 163
1930 Zaventem
Phone: (+32) 27 20 921 2
info@gardena.be

Brazil

Palash Comércio
e Importação Ltda
Rua Helena, 285 cjto 12
Vila Olimpia – São Paulo – SP
04552-050
Phone: (+55) 11 30 45 33 00
eduardo@palash.com.br

Bulgaria

DENEX LTD.
2 Luis Ahalier Str., 7th floor
Sofia 1404
Phone: (+359) 2 9581821
office@denex-bg.com

Canada

GARDENA Canada Ltd.
100 Summerlea Road
Brampton, Ontario L6T 4X3
Phone: (+1) 905 792 93 30
info@gardenacanada.com

Chile

Antonio Martinic Y CIA. LTDA.
Gilberto Fuenzalida 185 Loc.
Las Condes - Santiago de Chile
Phone: (+56) 2 20 10 708
garfar_cl@yahoo.com

Costa Rica

Compania Exim
Euroiberoamericana S.A.
Los Colegios, Moravia,
200 metros al Sur del
Colegio Saint Francis
San José
Phone: (+506) 223 20 75
exim_euro@racsa.co.cr

Croatia

KLIS d.o.o.
Stančićeva 79
10419 Vukovina
Phone: (+385) 1 622 777 0
klis@zg.hinet.hr

Cyprus

FARMOKIPIKI LTD
P.O. Box 7098
74, Digeni Akrita Ave.
1641 Nicosia
Phone: (+357) 22 75 47 62
condam@spidernet.com.cy

Czech Republic

GARDENA spol. s.r.o.
Řípská 20a, č.p. 1153
62700 Brno
Phone: (+420) 800 100 425
(Hotline)
gardena@gardenabrno.cz

Denmark

GARDENA Norden AB
Sales Office Denmark
Box 9003
S-200 39 MALMÖ
info@gardena.dk

Finland

Habitec Oy
Martinkyläntie 52
01720 Vantaa

France

GARDENA France
PARIS NORD 2
69, rue de la Belle Etoile
BP 57080 ROISSY EN FRANCE
95948 ROISSY CDG CEDEX
Tél. : (+33) 0826 101 455
service.consommateurs@
gardena.fr

Great Britain

GARDENA UK Ltd.
27-28 Brenkley Way
Blezard Business Park
Seaton Burn
Newcastle upon Tyne
NE16DS
info@gardena.co.uk

Greece

Agrokip G. Psomadopoulos
& Co.
33 A, Ifestou str.
Industrial Area
194 00 Koropi, Athens
Phone: (+30) 210 66 202 256
service@agrokip.gr

Hungary

GARDENA Magyarország Kft.
Késmárk utca 22
1158 Budapest
Phone: (+36) 80 20 40 33
(Hotline)
gardena@gardena.hu

Iceland

Ó. Johnson & Kaaber
Tunguhals 1
100 Reykjavik

Ireland

McLoughlin's Ltd.
Unit 5
Norther Cross Business Park
North Road, Finglas
Dublin 11

Italy

GARDENA Italia S.p.A.
Via Donizetti 22
20020 Lainate (MI)
Phone: (+39) 02.93.94.79.1
info@gardenaitalia.it

Japan

KAKUICHI co., Ltd.
Sumitomo Realty & Develop-
ment Kojimachi BLDG., 8F
5 – 1 Nibanncho, chiyoda-ku,
Tokyo 102-0084
Phone: (+81)-(0)3-3264-4721
m_ishihara@kaku-ichi.co.jp

Luxembourg

Magasins Jules Neuberger
Boîte postale 12
L-2010 Luxembourg
rue Gluck
L-2549 Luxembourg-Gasperich
Phone: (+352) - 401 401
info@neuberger.lu

Netherlands

GARDENA Nederland B.V.
Postbus 50176
1305 AD ALMERE
Phone: (+31) 36 521 00 00
info@gardena.nl

Neth. Antilles

Jonka Enterprises N.V.
Sta. Rosa Weg 196
P.O. Box 8200
Curaçao
Phone: (+599) 9 767 66 55
pgm@jonka.com

New Zealand

NYLEX New Zealand Ltd.
Private Bag 94001
South Auckland Mail Centre
10 Offenhauser Drive
East Tamaki, Manukau
Phone: (+64) 9 270 1806
david.eeles@nylex.com.au

Norway

GARDENA Norden AB
Sales Office Norway
Karihaugveien 89
1089 OSLO

Poland

GARDENA Polska Sp. z o.o.
Szymanów 9d
05-532 Baniocza
Phone: (+48) 22 727 56 90
gardena@gardena.pl

Portugal

GARDENA Portugal Lda.
Edif. GARDENA
Algueirão
2725-596 Mem Martins
Phone: 219228530
info@gardena.pt

Romania

MADEX International
Str. Avionului No. 17
Bl. 6D, SC.1
AP.1 Sector 1
Bucharest
Phone: (+40) 21 23 23 570
madex@ines.ro

Russia / Россия

ООО «ГАРДЕНА РУС»
Хорошевское шоссе, д. 32А
123 007 г. Москва

Singapore

Hy-Ray Enterprises
Block 1002 Toa Payoh
Industrial Park
07-1433/1435/1451
Singapore 319074
Phone: (+65) 625 32 277
hyray@singnet.com.sg

Slovak Republic

GARDENA Slovensko s.r.o.
Bohrova 1
851 01 Bratislava
Phone: (+421) 263 453 722
info@gardena.sk

Slovenia

Silk d.o.o. Trgovina
Brodišče 15
1236 Trzin
Phone: (+386) 1 580 93 00
gardena@silk.si

South Africa

GARDENA
South Africa (Pty.) Ltd.
P.O. Box 11534
Vorna Valley 1686
Phone: (+27) 11 315 02 23
sales@gardena.co.za

Spain

GARDENA IBÉRICA S.L.U.
C/Basauri, nº 6
La Florida
28023 Madrid
Phone: (+34) 91 708 05 00
(4 líneas)
atencioncliente@gardena.es

Sweden

GARDENA Norden AB
Försäljningskontor Sverige
Box 9003
20039 Malmö
info@gardena.se

Switzerland / Schweiz

GARDENA (Schweiz) AG
Bitziberg 1
8184 Bachenbülach
Tel.: (+41) 18 60 26 66
info@gardena.ch

Turkey

GARDENA / Dost Diş Ticaret
Mümesillik A.Ş. Sanayi
Çad. Adil Sokak No. 1
Kartal – İstanbul
Phone: (+90) 216 38 93 939
info@gardena-dost.com.tr

Ukraine / Украина

Київська область
Київо-Святошинський район
Село Петропавлівська
Борщагівка
Вул. Петропавлівська, 4
(Кільцева дорога)
Тел.: (+380) 44 220 4335
info@gardena.ua

USA

GARDENA
Melnor, 3085 Shawnee Drive
Winchester, VA 22604
Phone: (540) 722-9080
service_us@melnor.com

2613-20.961.02/0605
© GARDENA Manufacturing GmbH
D-89070 Ulm
http://www.gardena.com