

Art. 2691

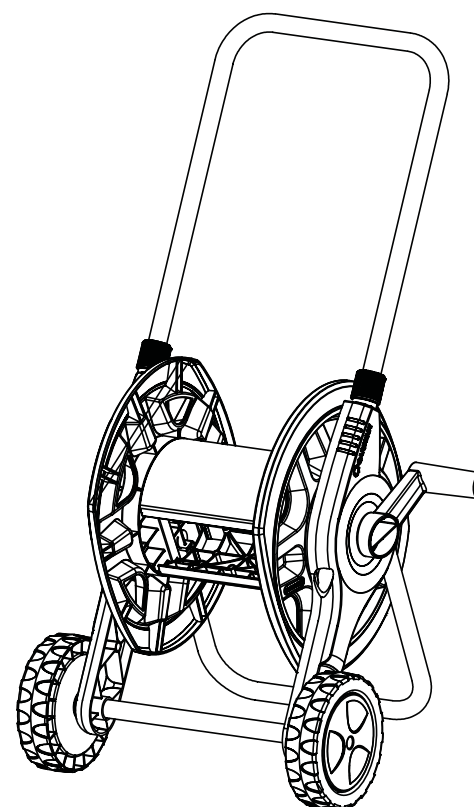

Art. 2692

D	Montageanleitung Schlauchträger / Schlauchwagen
GB	Assembly Instructions Hose Reel / Hose Trolley
F	Instructions de montage Dévidoir portable / Dévidoir sur roues
NL	Montage-instructie Slanghouder / Slangenwagen
S	Monteringsanvisning Slangvinda / Slangvagn
I	Istruzioni di montaggio Avvolgitubo / Carrelli avvolgitubo
E	Instrucciones de montaje Portamangueras / Carros portamangueras
P	Instruções de montagem Porta Mangueiras / Carros porta-mangueiras
DK	Monteringsvejledning Slangetromle / Slangevogn

D Montage:

Zur Montage benötigen Sie einen Kreuzschlitz-Schraubendreher.

1. Schlauchwagen/-träger entsprechend der Bildfolge **A** montieren. Schubbügel bei Erstmontage über den spürbaren Anschlag vollständig einschieben.
2. Trommel entsprechend der Bildfolge **B** montieren.
3. Kurbel und Anschluss-Hülse entsprechend der Bildfolge **C** montieren.

Lagerung:

→ Vor der Frostperiode den Schlauchwagen frostsicher lagern.

GB Assembly:

You will need a Phillips (cross-head) screwdriver to assemble your hose trolley.

1. Assemble hose trolley/hose reel as shown in diagram sequence **A**.
When assembling for the first time, push in the guide handle over the catch as far as it will go.
2. Assemble drum as shown in diagram sequence **B**.
3. Assemble crank handle and connection as shown in diagram sequence **C**.

Storage:

→ Store your hose trolley away from frost before the first frost sets in.

F Montage:

Pour le montage vous avez besoin d'un tournevis cruciforme.

1. Monter le dévidoir sur roues/dévidoir portable suivant les illustrations **A**.
Lors du premier montage, enfoncer entièrement l'étrier de poussée en dépassant la butée.
2. Monter le tambour suivant les illustrations **B**.
3. Monter la manivelle et raccord suivant les illustrations **C**.

Stockage:

→ Ranger le chariot à l'abri du gel avant la saison froide.

NL Montage:

Voor de montage heeft u een kruiskopschroevendraaier nodig.

1. Slangenwagen/slanghouder in de volgorde op afbeelding **A** monteren.
Duwerbeugel bij eerste montage volledig over de voelbare aanslag inschuiven.
2. Trommel in de volgorde van afbeelding **B** monteren.
3. Kruk en aansluiting in de volgorde van afbeelding **C** monteren.

Opslag:

→ Voor de vorstperiode de slangenwagen vorstvrij opbergen.

S Montering:

För montering behövs en stjärnskruvmejsel.

1. Montera slangvagn/slangvinda enligt bildserie **A**.
Vid första montering: Skjut in handtaget helt tills det tar emot.
2. Montera trumman enligt bildserie **B**.
3. Montera veven och anslutning enligt bildserie **C**.

Förvaring:

→ Lagra slangförvaringen på frostsäker plats.

I Montaggio:

Per montare il carrello, servirsi di un cacciavite a croce.

1. Assemblare le altre parti come da fig. **A**.
Inserire semplicemente il manico spingendolo a fondo fino alla battuta.
2. Montare il tamburo attenendosi alla figura **B**.
3. Montare la manovella e collegamento attenendosi alla figura **C**.

Ricovero:

→ Prima dell'inverno riporre il carrello avvolgitubo in luogo riparato.

E Montaje:

Para el montaje necesita un destornillador para tornillos con ranura en cruz.

1. Montar el carro portamanguera/portamanguera como muestra la figura **A**.
Introducir la barra de empuje, en el primer montaje, completamente hasta el tope perceptible.
2. Montar el tambor como muestra la figura **B**.
3. Montar la manivela y conexión como muestra la figura **C**.

Almacenaje:

→ Guardar el carro portamangueras en lugar protegido contra las heladas durante el invierno.

P Montagem:

Para montagem necessita de uma chave de parafusos Philips.

1. Montar o carro de mangueira/porta mangueiras de acordo com a sequência de imagens **A**.
Em caso da primeira montagem, insira o estribo de manobra completamente, para além da primeira resistência do entalhe.
2. Montar o tambor de acordo com a sequência de imagens **B**.
3. Montar da manivela e ligação de acordo com a sequência de imagens **C**.

Armazenamento:

→ Guardar o carro de mangueira ao abrigo de geadas, antes do início do período de geadas.



DK Montering:

Du skal bruge en stjerneskruetrækker for at samle din slangevogn.

1. Slangevognen/slangetromle monteres i henhold til billederne **A**.
Skydebøjlen skal skubbes fuldstændigt ind over det mærkbare anslag ved første montering.
2. Tromlen monteres i henhold til billederne **B**.
3. Håndsving og kobling monteres i henhold til billederne **C**.

Opbevaring:

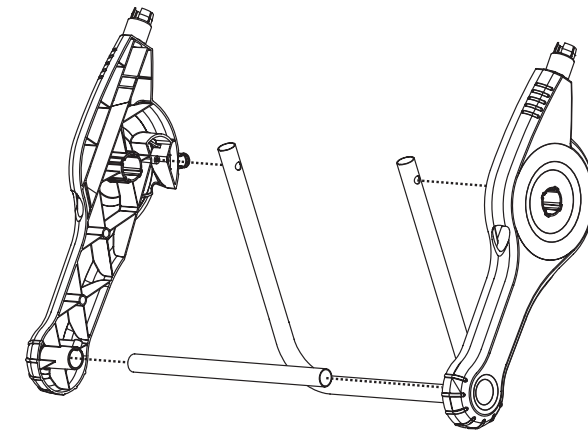
→ Før frostperioden skal slangevognen opbevares på et frostfrit sted.

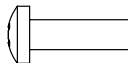
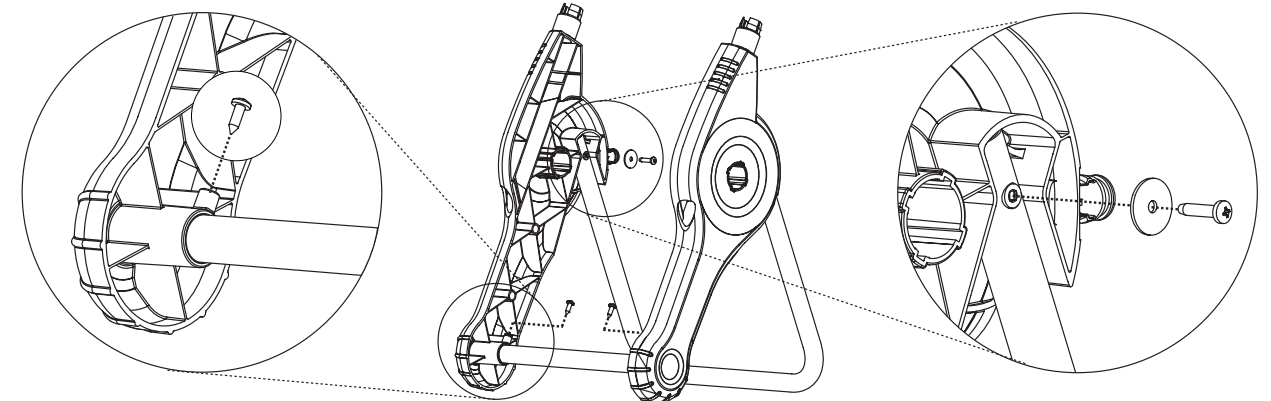
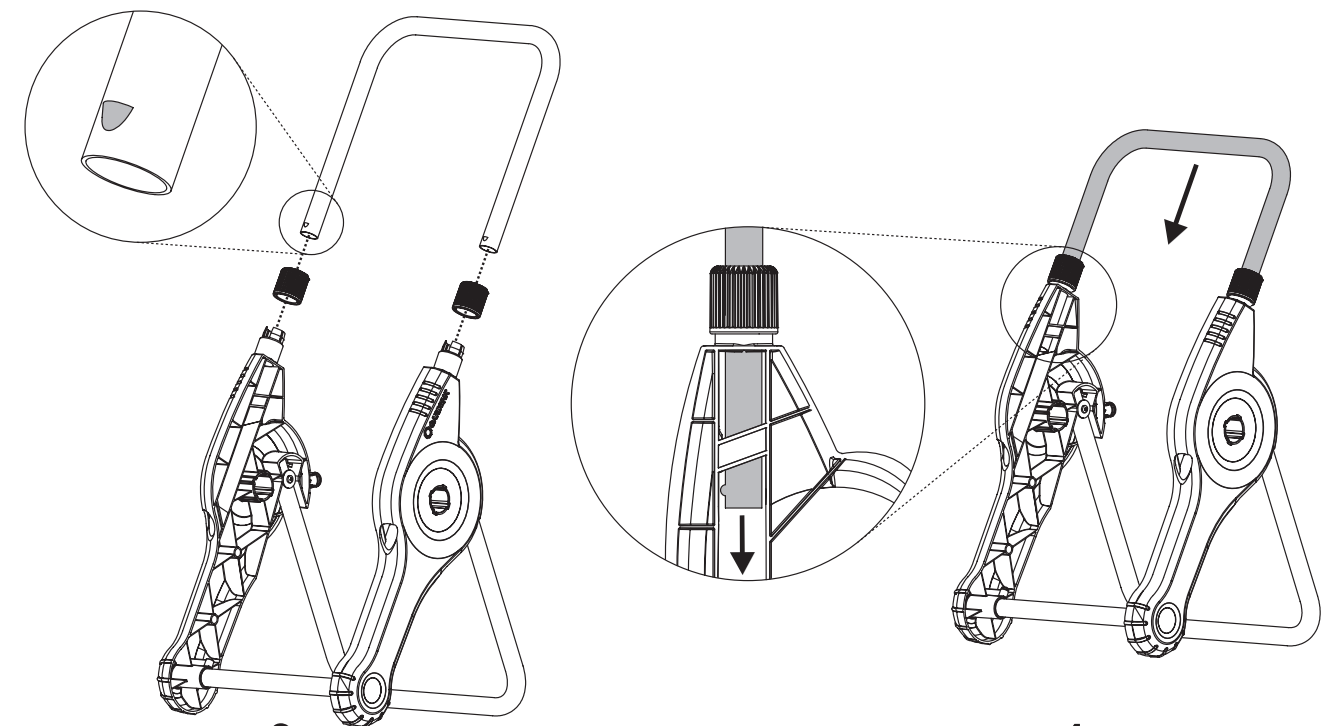
A 2691**1**2 x  4,2 x 13 mm2 x  4,2 x 19 mm**2****3****4**

A 2692

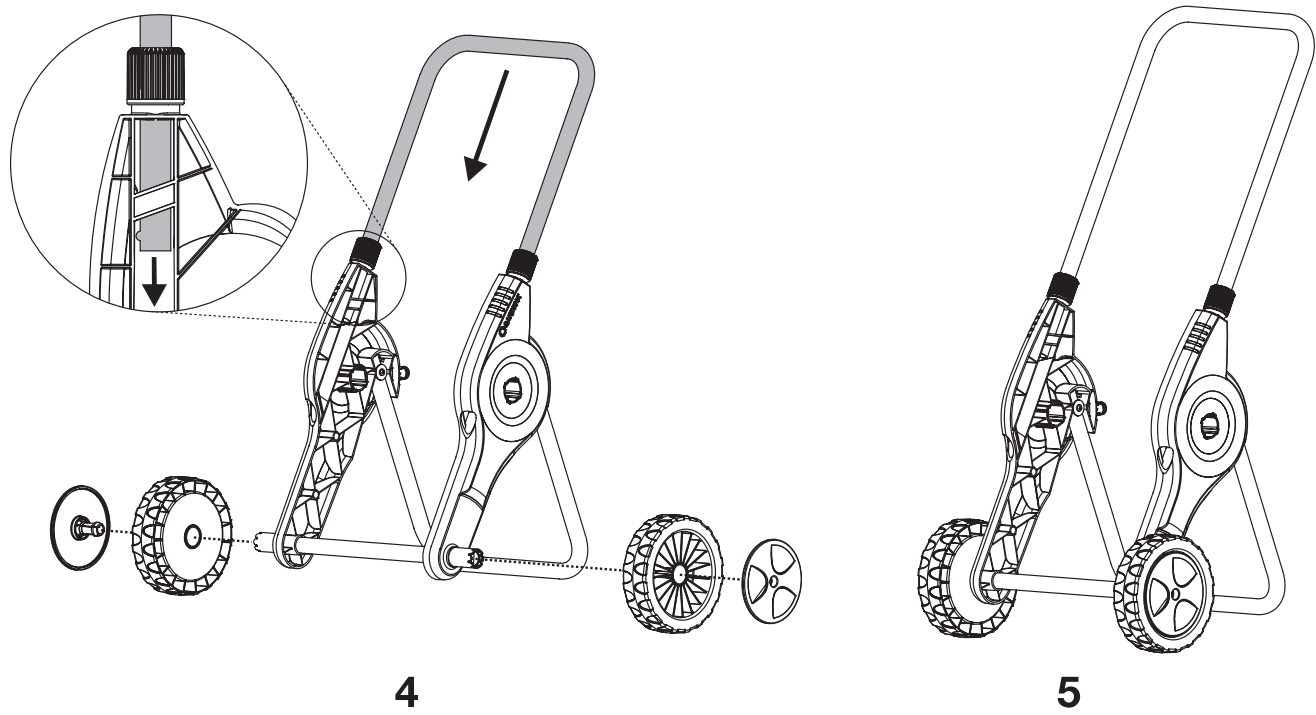
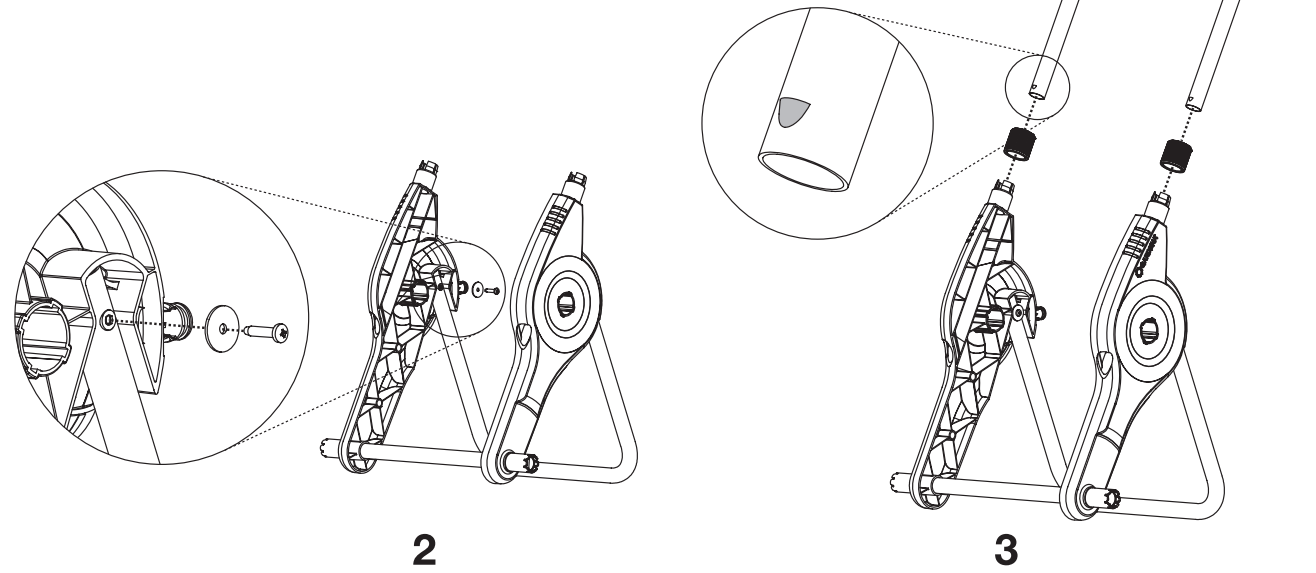
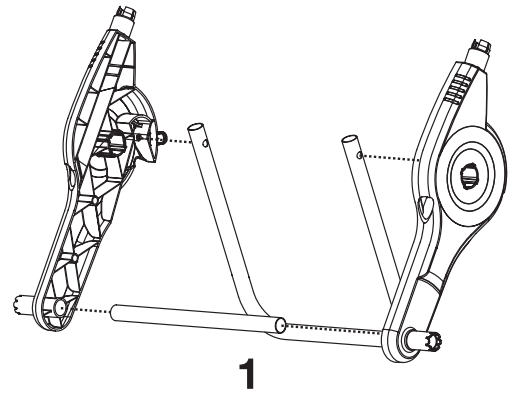

B

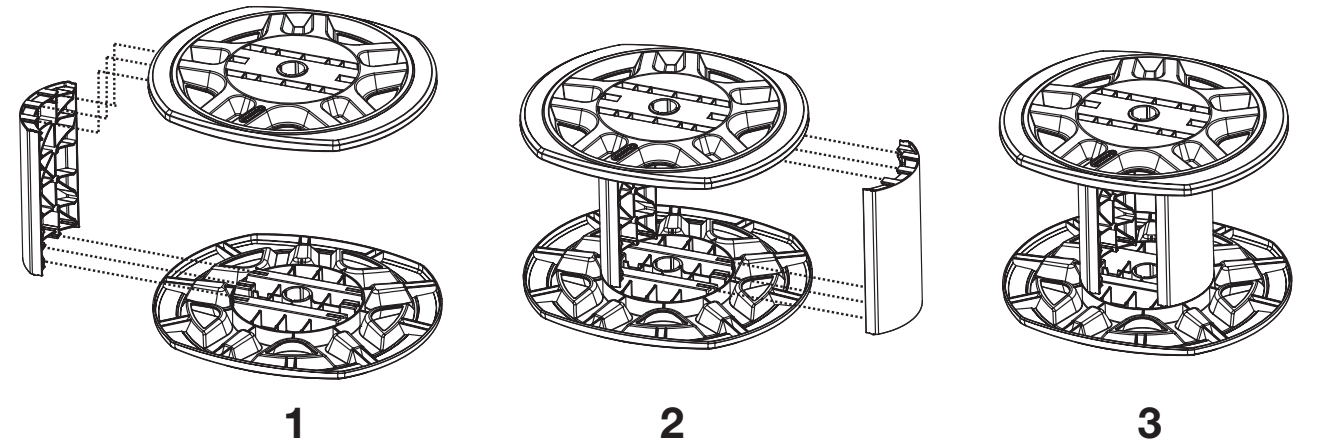

C 2691

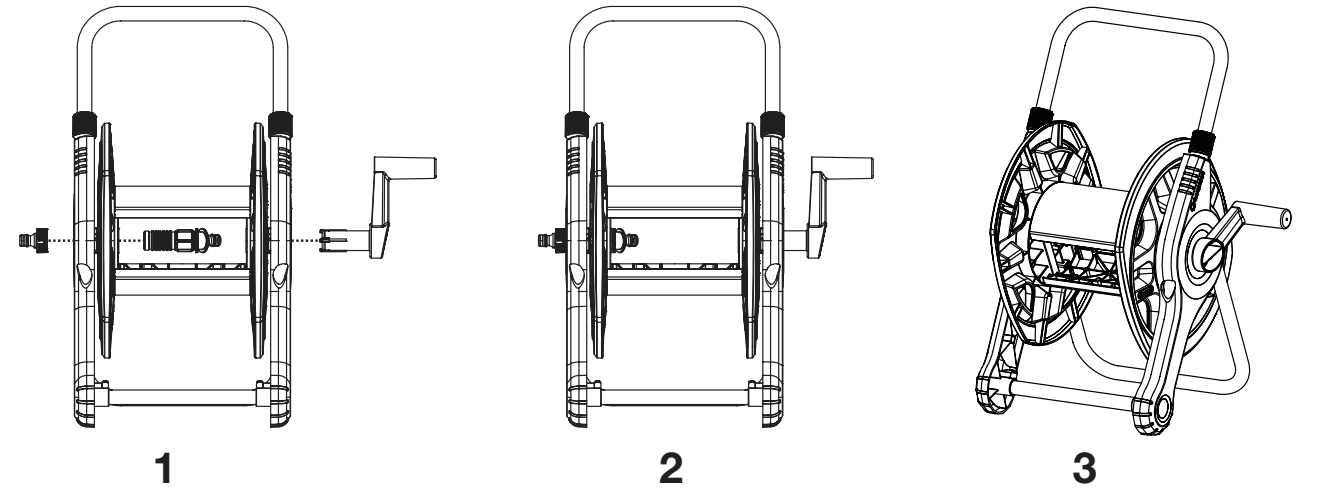

C 2692

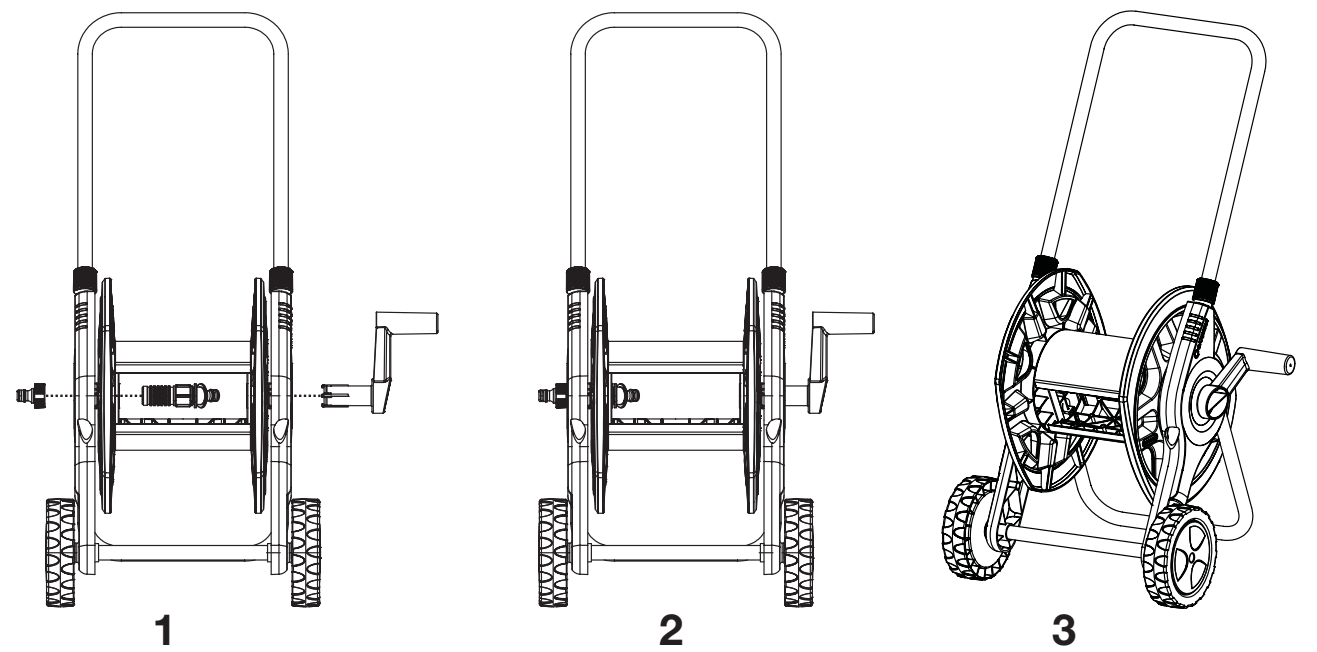

Service

Deutschland / Germany

GARDENA
Manufacturing GmbH
Service Center
Hans-Lorenser-Str. 40
89079 Ulm
Produktfragen:
(+49) 731 490-123
Reparaturen:
(+49) 731 490-290
service@gardena.com

Argentina

Argensem de Comercializa-
dora Mecafon S.A.
Casilla de Correo 193
(1625) Escobar,
Pcia. de Buenos Aires
Phone: (+54) 34 88 49 40 40
info@argensem.com.ar

Australia

NYLEX Consumer Products
50 – 70 Stanley Drive
Somerton, Victoria, 3062
Phone: 1800 658 276
spare.parts@nylex.com.au

Austria / Österreich

GARDENA Österreich
Ges. m.b.H.
Stettnerweg 11-15
2100 Korneuburg
Tel.: (+43) 22 62 745 45-36 od.
-30
kundendienst@gardena.at

Belgium

GARDENA Belgium NV/SA
Sterrebeekstraat 163
1930 Zaventem
Phone: (+32) 27 20 921 2
info@gardena.be

Brazil

Palash Importação
e Comércio Ltda
Rua Américo Brasiliense
2414 – Chácara Sto. Antonio
São Paulo – SP –
CEP 04715-005, Brazil
Phone: (+55) 11 5181-20 20
eduardo@palash.com.br

Bulgaria

DENEX LTD.
2 Luis Ahalier Str., 7th floor
Sofia 1404
Phone: (+359) 2 9581821
office@denex-bg.com

Canada

GARDENA Canada Ltd.
100 Summerlea Road
Brampton, Ontario L6T 4X3
Phone: (+1) 905 792 93 30
info@gardenacanada.com

Chile

Garden Chile S.A.
San Sebastián 2839
Ofic. 701 A
Las Condes - Santiago de Chile
Phone: (+56) 2 20 10 708
garfar_cl@yahoo.com

Costa Rica

Compania Exim
Euroberoamericana S.A.
Aptdo Postal 1260
San José
Phone: (+506) 223 20 75
exim_euro@racsa.co.cr

Croatia

KLIS d.o.o.
Stančićeva 79
10419 Vukovina
Phone: (+385) 1 622 777 0
gardena@klis-trgovina.hr

Cyprus

FARMOKIPIKI LTD
P.O. Box 7098
74, Digeni Akrita Ave.
1641 Nicosia
Phone: (+357) 22 75 47 62
condam@spidernet.com.cy

Czech Republic

GARDENA spol. s.r.o.
Řípská 20a, č.p. 1153
62700 Brno
Phone: (+420) 800 100 425
(Hotline)
gardena@gardenabrno.cz

Denmark

GARDENA Norden AB
Sales Office Denmark
Box 9003
S-200 39 MALMÖ
info@gardena.dk

Finland

Habitec Oy
Tiilitie 14
01720 Vantaa

France

GARDENA France
PARIS NORD 2
69, rue de la Belle Etoile
BP 57080 ROISSY EN FRANCE
95948 ROISSY CDG CEDEX
Tél. : (+33) 0826 101 455
service.consommateurs@
gardena.fr

Great Britain

GARDENA UK Ltd.
27/28 Brenkley Way
Bleazard Business Park
Seaton Burn
Newcastle upon Tyne
NE13 6DS
info@gardena.co.uk

Greece

Agrokip-Psomadopoulos S. A.
33 A, Ifestou str.
Industrial Area
194 00 Koropi, Athens
Phone: (+30) 210 66 20-2 25
and -2 26
service@agrokip.gr

Hungary

GARDENA Magyarország Kft.
Késmárk utca 22
1158 Budapest
Phone: (+36) 80 20 40 33
(Hotline)
gardena@gardena.hu

Iceland

Ó. Johnson & Kaaber
Tunguhalsi 1
110 Reykjavik

Ireland

McLoughlin's Ltd.
Unit 5
Norther Cross Business Park
North Road, Finglas
Dublin 11

Italy

GARDENA Italia S.p.A.
Via Donizetti 22
20020 Lainate (MI)
Phone: (+39) 02.93.94.79.1
info@gardenaitalia.it

Japan

KAKUICHI co., Ltd.
Sumitomo Realty & Develop-
ment Kojimachi
BLDG., 8F
5 – 1 Nibanncoyo, chiyoda-ku,
Tokyo 102-0084
Phone: (+81)-(0)3-3264-4721
m_ishihara@kaku-ichi.co.jp

Luxembourg

Magasins Jules Neuberg
Boîte postale 12
L-2010 Luxembourg
rue Gluck
L-2549 Luxembourg-Gasperich
Phone: (+352) - 401 401
info@neuberg.lu

Netherlands

GARDENA Nederland B.V.
Postbus 50176
1305 AD ALMERE
Phone: (+31) 36 521 00 00
info@gardena.nl

Neth. Antilles

Jonka Enterprises N.V.
Sta. Rosa Weg 196
P.O. Box 8200
Curaçao
Phone: (+599) 9 767 66 55
pgm@jonka.com

New Zealand

NYLEX New Zealand Ltd.
Building 2
118 Savill Drive
Mangere, Auckland
Phone: +64 9 270 1806
lena.chapman@nylex.com.au

Norway

GARDENA Norden AB
Sales Office Norway
Karihaugveien 89
1089 OSLO

Poland

GARDENA Polska Sp. z o.o.
Szymanów 9d
05-532 Baniocza
Phone: (+48) 22 727 56 90
gardena@gardena.pl

Portugal

GARDENA Portugal Lda.
Edif. GARDENA
Algueirão
2725-596 Mem Martins
Phone: 219228530
info@gardena.pt

Romania

MADEXINTERNATIONALSRL
Șoseaua Odăii 117 – 123
Sector 1, București,
RO 013603
Phone: (+40) 21 352-7603/
4/5/6
madex@gardena.ro

Russia / Россия

ООО «ГАРДЕНА РУС»
Хорошевское шоссе, д. 32А
123 007 г. Москва

Singapore

HY-RAY PRIVATE LIMITED
40 JALAN PEMIMPIN
#02-08 Tat Ann Building
Singapore 577185
Phone: (+65) 625 32 277
hyray@singnet.com.sg

Serbia

DOMEL d.o.o.
Savski Nasip 7
11070 Novi Beograd
Serbia
Phone: (+381) 11 2772 204
miroslav.jejina@domel.co.yu

Slovenia

GARDENA d.o.o.
Brodšče 15
1236 Trzin
Phone: (+386) 1 580 93 32
servis@gardena.si

South Africa

GARDENA
South Africa (Pty.) Ltd.
P.O. Box 11534
Vorna Valley 1686
Phone: (+27) 11 315 02 23
sales@gardena.co.za

Spain

GARDENA IBÉRICA S.L.U.
C/Basauri, nº 6
La Florida
28023 Madrid
Phone: (+34) 91 708 05 00
(4 líneas)
atencioncliente@gardena.es

Sweden

GARDENA Norden AB
Försäljningskontor Sverige
Box 9003
20039 Malmö
info@gardena.se

Switzerland / Schweiz

GARDENA (Schweiz) AG
Brüelstrasse 4
8157 Dielsdorf
Tel.: 01/860 26 66
info@gardena.ch

Turkey

GARDENA Dost Dış Ticaret
Müessillik A.Ş.
Sanayi Çad. Adil Sok. No.1
34873 Kartal – Istanbul
Phone: (+90) 216 38 93 939
info@gardena-dost.com.tr

Ukraine / Україна

Altsest JSC
4 Petropavlivska Street
Petropavlivska Borschahivka
Town
08130 Kyivo Svyatoshyh
Region
Phone: +380 44 4595703
info@gardena.ua

USA

GARDENA
Melnor, 3085 Shawnee Drive
Winchester, VA 22601
Phone: (540) 722-9080
service_us@melnor.com

2691-20.961.01/1006
© GARDENA Manufacturing GmbH
D-89070 Ulm
http://www.gardena.com