

DIXON[®] ZTR[®]

RAM SERIES[™]
ZTR[®]

**Safety Instructions
and
Operator's Manual**

RAM 44, BS/968999551	RAM MAG 50, KAW/968999561
RAM 50, BS/968999552	RAM 50 MAG, HON/968999562
RAM MAG 44, HON/968999559	RAM 50 MAG KOH/968999563
RAM MAG 44, KOH/968999560	

IMPORTANT - READ CAREFULLY

The Dixon® ZTR® mower is both easy and fun to operate. However, any power mower must be operated properly to be safe. It is not a toy or a recreational vehicle. Before you start to use the mower, read this Operator's Manual carefully. It contains valuable information that is necessary for the safe operation of the machine. Observe all safety rules and become completely familiar with the controls.

The information contained in this manual applies to all Dixon Ram Series™ ZTR® mowers.

See your authorized Dixon dealer for warranty service, parts and repairs or to answer any questions you may have about your new Dixon ZTR.

TABLE OF CONTENTS

GENERAL OPERATION	8-9
SLOPE OPERATION	10-11
FIRE HAZARDS	12-13
CHILDREN, BYSTANDERS AND PETS	14
SERVICE	15
SPECIFICATIONS	12-23
RAM SERIES™ 50 Model 968999552	18
CONTROLS	
CONTROL LEVERS	25
PARK BRAKE	26
BLADE DRIVE	27
CHOKE AND THROTTLE CONTROL LEVER	27
MOWER DECK CUT HEIGHT LIFT LEVER	28
OPERATIONS	29-39
BEFORE OPERATING MOWER	29
STARTING INSTRUCTIONS	30
TESTING SAFETY INTERLOCK SYSTEMS	31-32
MULCHING ATTACHMENT	33
CATCHER ATTACHMENT	35-36
SIDE DISCHARGE	37
GRASS HEIGHT	38
TOWING	39
CARE AND MAINTENANCE	39-47
UNLOCK TRANSMISSION	39
CUTTER BLADES	41
BELTS	42
BATTERY	42
LUBRICATION	44
TRACKING ADJUSTMENT	45
DECK LEVELING	46
CLEANING	47
PARTS/SERVICE	47
TROUBLESHOOTING	48-49
STANDARD SERVICE PARTS LIST	50

SAFETY



RIDING LAWN MOWERS, IF IMPROPERLY OPERATED, CAN CAUSE SERIOUS INJURY OR DEATH

Pictured below are the most common causes of injury to the operator or bystander. Please read and understand this manual to prevent injuries.^{asdf}

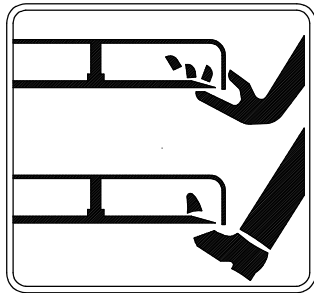

Blade Contact



Tip Over

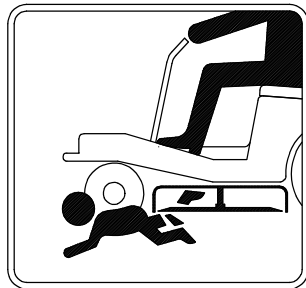

Run Over



Back Over

SAFETY



When you see this symbol, BE ALERT to the potential for injury.

Follow the recommended safety precautions and safe operating practices.



DANGER
(highlighted in red)
indicates an imminently hazardous situation which, if not avoided, will result in death or serious injury.



WARNING
(highlighted in orange)
indicates a potentially hazardous situation which, if not avoided, could result in death or serious injury.



CAUTION
(highlighted in yellow)
indicates a potentially hazardous situation which, if not avoided, may result in minor or moderate injury. It may also be used to alert against unsafe practices.

WARNING



WARNING Failure to observe the following instructions could result in serious injury or death.

GENERAL OPERATION

Read, understand, and follow all instructions in this manual and on the mower before starting.

Only allow responsible adults, who are familiar with the instructions, to operate the mower.

Clear the area of objects such as rocks, toys, wire, etc., that could be picked up and thrown by the blade.

Be sure the area is clear of bystanders before mowing. Stop mower if anyone enters the area.

Never direct discharged material toward anyone. Avoid discharging against a wall or obstruction. Material may ricochet back toward the operator. Stop the blade(s) when crossing gravel surfaces.

Do not operate the mower without either the entire grass catcher or the deflector in place. This will decrease the possibility of injury from objects being thrown by the mower blades.

Never carry passengers.

Do not mow in reverse unless absolutely necessary. Always look down and behind before and while backing.

Never leave a running mower unattended. Always turn off blades, set park brake, stop engine and remove key before dismounting.

The engine exhaust from this product contains chemicals known to the State of California to cause cancer, birth defects or other reproductive harm.

WARNING



WARNING Failure to observe the following instructions could result in serious injury or death.

GENERAL OPERATION (continued)

Turn off blades when not mowing. Injury could occur from contact with moving parts.

Under no circumstances should you place hands or feet under the mower deck or in the chute while blades or impeller are still running.

To avoid personal injury from accidental clutch engagement, stop engine before removing grass catcher or unclogging chute.

Mow only in daylight or good artificial light.

Do not operate the mower while under the influence of alcohol or drugs.

Slow down before turning to reduce the risk of tip-over.

Watch for traffic when operating near or crossing roadways.

Use extra care when loading or unloading the mower into a trailer or truck. Push, do not ride the mower when loading and unloading.

Protect your eyes. Always wear safety goggles or safety glasses with side shields when operating mower.

Data indicates that operators, age 60 years and above, are involved in a large percentage of riding mower-related injuries. These operators should evaluate their ability to operate the riding mower safely enough to protect themselves and others from serious injury.

To protect against possible tip-over, follow the manufacturer's recommendation for wheel weights and counterweights.

Maintain or replace safety and instruction labels as needed.

WARNING



WARNING Failure to observe the following instructions could result in serious injury or death.

SLOPE OPERATION

Slopes are a major factor related to loss-of-control and tip-over accidents, which can result in severe injury or death.

All slopes require extra caution. If you feel unsure on any slope, do not mow it!

DO

Mow across the slope with your Dixon ZTR — never up or down. This will decrease the risk of tip-over.

Remove obstacles such as rocks, tree limbs, wires and other foreign objects that can be thrown by mower blades.

Watch for holes, ruts, roots and bumps, and uneven terrain that could overturn the mower. Tall grass can hide such obstacles.

Use slow speed. Tires may lose traction on slopes even though the brakes are functioning properly.

Avoid starting or stopping on a slope. If tires lose traction, disengage the blades and proceed slowly down the slope.

Keep all movement on the slopes slow and gradual. Do not make sudden changes in speed or direction.

Use extreme caution when operating the mower with attachments to prevent tip-over or roll-over.

If front wheels lift off the ground, pull levers back to stabilize the mower. Discontinue mowing the slope!

WARNING



WARNING Failure to observe the following instructions could result in serious injury or death.

SLOPE OPERATION (*continued*)

DO NOT

Do not turn on slopes unless necessary, and then, turn slowly and gradually downhill, if possible. Rapid uphill turns may cause tip-over.

Do not mow near drop-offs, ditches, or embankments. Unstable ground may cause loss of control.

Do not mow on wet grass. Reduced traction could cause sliding.

Do not try to stabilize the mower by putting your foot on the ground.

Do not use grass catcher or other attachments on steep slopes. The added weight may change the stability of the mower, creating the potential for tip-over.

WARNING



WARNING Failure to observe the following instructions could result in serious injury or death.

FIRE HAZARDS

Use extra care when handling gasoline and other fuels. They are flammable and vapors are explosive.

Store all fuel in approved containers specifically designed for that purpose.

Allow engine to cool before refueling. Never remove fuel cap or add fuel with engine running.

Do not smoke while refueling or operating the mower.

To reduce fire hazard, keep mower free of grass, leaves and other debris buildup.

If gasoline is spilled, do not attempt to start the engine. Move mower away from the area of the spill. Do not create any source of ignition until gas vapors have dissipated. Wipe up spilled fuel and dispose of waste properly.

If fuel is spilled on clothing, change clothing immediately.

Before storing, allow mower to cool. Clean fuel and oil spillage.

Never store the mower or fuel container inside a building where there is an open flame.

WARNING



WARNING Failure to observe the following instructions could result in serious injury or death.

FIRE HAZARDS (continued)

To prevent fire or explosion, keep sparks and open flames away from battery.

Keep electrical connections clean and tight. Inspect them often. Loose connections and corrosion increase fire risk.

Before disconnecting the negative ground cable, make sure all switches are off. This decreases the chance of sparking and fire.

Use care when backing to avoid pushing the grass bags into the frame or “hot” exhaust muffler of the engine. Fire could result.

To prevent fire and explosion caused by *static electricity*:

Never fill containers inside a vehicle or on a truck or trailer bed with a plastic liner. Always place containers on the ground away from your vehicle before filling.

When practical, remove fuel powered equipment from the truck or trailer and refuel it on the ground. If this is not possible, refuel such equipment on a trailer with a portable container, rather than from a fuel dispenser nozzle.

If a fuel dispenser nozzle must be used, keep the nozzle in contact with the rim of the fuel tank or container opening at all times until fueling is complete. Do not use a nozzle lock-open device.

WARNING



WARNING Failure to observe the following instructions could result in serious injury or death.

CHILDREN, BYSTANDERS AND PETS

Tragic accidents can occur if the operator is not alert to the presence of children, bystanders and pets.

Children are attracted to lawn mowers and the mowing activity.

NEVER assume children, bystanders and pets will stay where they were last seen.

Be alert to avoid accidents.

Keep bystanders and pets out of the mowing area and keep children under the watchful care of another responsible adult.

Be alert and turn mower off if bystanders, children or pets enter the area.

Before and during backing look BEHIND and DOWN for small children.

Never carry children as passengers. They may fall off and be seriously injured or interfere with safe mower operation.

Never allow children to operate the mower.

Use extra care when approaching blind corners, shrubs, trees, or other objects that may obscure vision.

WARNING



WARNING Failure to observe the following instructions could result in serious injury or death.

SERVICE

Never run a mower inside a closed area or without proper ventilation.

Keep nuts and bolts tight, especially blade attachment bolts, and keep equipment in good condition.

Never tamper with safety devices. Check their proper operation regularly.

Stop and inspect the equipment if you strike an object. Repair, if necessary, before restarting.

Never make adjustments or repairs with the engine running unless otherwise specified.

Grass catcher components are subject to wear, damage and deterioration that could expose moving parts or allow objects to be thrown. Frequently check components. Replace with original equipment parts when necessary.

When servicing blades, wrap blades or wear gloves, and use extra caution.

Batteries contain sulfuric acid. To prevent burns, avoid contact with skin, eyes and clothing.

DIXON® ZTR® COMMERCIAL / RESIDENTIAL WARRANTY POLICY
RAM 44, RAM 50, RAM 44 MAG™ & RAM 50 MAG™

DIXON® WARRANTS ITS ZTR® MOWERS AGAINST DEFECTS IN MATERIAL AND WORKMANSHIP FOR THE PERIODS SET FORTH BELOW. THE SOLE REMEDY UNDER THIS WARRANTY IS REPLACEMENT OR REPAIR OF PARTS INCLUDING LABOR COSTS.

THIS WARRANTY IS SUBJECT TO THE FOLLOWING CONDITIONS AND LIMITATIONS:

1. COMMERCIAL WARRANTY (use other than, or in addition to, mowing at owner's primary place of residence):
 - a. One Year-100% parts and labor subject to the conditions and limitations described herein for a period of one year from date of purchase by the original owner.
 - b. Attachments marketed through or approved by Dixon are warranted for one year parts and labor in commercial use applications.
 - c. The RAM 44, RAM 50, RAM 44 MAG™ and RAM 50 MAG™ are not subject to hour meter restrictions.
 - d. Warranty applies to new mowers.
2. RESIDENTIAL WARRANTY (used only at owner's primary place of residence):
 - a. Two years-100% parts and labor subject to the conditions and limitations described herein for a period of two years from date of purchase by the original owner.
 - b. Third year-limited to 100% parts cost as shown in the current Dixon® Parts Price List and subject to the conditions and limitations as described herein.
 - c. Attachments marketed through or approved by Dixon are warranted for two years parts and labor in residential use applications.
 - d. Warranty applies to new mowers.
3. Lifetime warranty on all frames and leading edge of all floricated (webbed) decks.
4. All Dixon® warranty must be accomplished by authorized Dixon® dealers and in accordance with Dixon® warranty policy and allowances.
All warranty claims must be submitted to Dixon for approval.
5. Warranty labor reimbursement to dealers based on published Dixon® flat rate schedule.
6. Warranty does not apply to damage in transit or incidents of misuse, negligence, accidents, or alteration.
The use of parts or components other than those supplied by Dixon voids ALL WARRANTY.
7. Battery warranty is limited to 1 year from mower manufacture date.
8. The following items are not covered by this warranty policy:
 - a. Routine maintenance or adjustments to include any oils, fluids or other fluids used.
 - b. Belts, blades, ties and cosmetic appearance (paint, seat fabric, etc.)
 - c. Pickup and delivery charges for transportation of mower to and from an authorized Dixon® dealer's place of business.
 - d. Engines. These are covered under a separate warranty by each individual engine manufacturer. Consult engine manual for warranty details.
 - e. Any costs or expense of providing substitute equipment while repair work is being performed on a warranted mower.
9. THERE IS NO OTHER EXPRESS WARRANTY. TO THE EXTENT PERMITTED BY LAW, IMPLIED WARRANTIES, INCLUDING THOSE OF MERCHANTABILITY AND FITNESS FOR A PARTICULAR PURPOSE ARE EXCLUDED, OTHERWISE, ALL SUCH IMPLIED WARRANTIES ARE LIMITED TO THE SAME DURATION AND REMEDIES AS THE EXPRESS WARRANTY. ALL LIABILITIES FOR CONSEQUENTIAL DAMAGES UNDER ANY EXPRESS OR IMPLIED WARRANTY ARE EXCLUDED.

SPECIFICATIONS

RAM SERIES™ 44 Model 968999551

Chassis:	1½" square tube side frame		
Mower Deck:	Made of 11 gauge fabricated welded construction with external reinforcement ribs. Three blades combine for a 42" (107cm) cut width. Cut height approximately 1½" (38mm) to 4½" (114 mm).		
Blade Drive:	Electric clutch		
Drive System:	Each rear wheel is independently driven by a Hydro Gear hydrostatic drive ZT2800 7" cooling fan.		
Engine:	26 HP Briggs & Stratton, twin cylinder, overhead valve, air cooled, gasoline, full pressure lube with oil filter, vertical shaft, aluminum head & block with cast- iron cylinder liners.		
Starting System:	Electric-key switch operation with safety interlocks on park brake and blade drive clutch.		
Tires:	Front	11 x 4.5 x 5 smooth tread	15 PSI (103 kPa)
	Rear	18 X 9.5 X 8 Turf pneumatic	15 PSI (103 kPa)
Capacities:	Fuel	4.9 gallon (19 liters) approximately	
	Engine Oil	2 qts. (1.8 liters) SAE 10W30 with filter	
Dimensions:	Width	44" (112 cm)	
	Height	40" (102 cm)	
	Length	69½" (177 cm)	
	Weight	625 lbs. (283 kg)	

Additional information may be provided elsewhere in this manual.

SPECIFICATIONS SUBJECT TO CHANGE WITHOUT NOTICE

SPECIFICATIONS

RAM SERIES™ 50 Model 968999552

Chassis:	1½" square tube side frame		
Mower Deck:	Made of 11 gauge fabricated welded construction with external reinforcement ribs. Three blades combine for a 48" (122cm) cut width. Cut height approximately 1½" (38mm) to 4" (114 mm).		
Blade Drive:	Electric clutch		
Drive System:	Each rear wheel is independently driven by a Hydro Gear ZT2800 hydrostatic drive 7" cooling fan.		
Engine:	26 HP Briggs and Stratton engine, overhead valve, air cooled, gasoline, full pressure lube with oil filter, vertical shaft, aluminum head and block with cast-iron cylinder liners.		
Starting System:	Electric-key switch operation with safety interlocks on park brake and blade drive clutch.		
Tires:	Front	11 x 4.5 x 5 smooth tread	15 PSI (103 kPa)
	Rear	18 X 9.5 X 8 Turf pneumatic	15 PSI (103 kPa)
Capacities:	Fuel	4.9 gallon (19 liters) approximately	
	Engine Oil	2 qts. (1.8 liters) SAE 10W30 with filter	
Dimensions:	Width	50" (112 cm)	
	Height	40" (102 cm)	
	Length	72" (183 cm)	
	Weight	605 lbs. (274 kg)	

Additional information may be provided elsewhere in this manual.

SPECIFICATIONS SUBJECT TO CHANGE WITHOUT NOTICE

SPECIFICATIONS

RAM MAG SERIES™ 44 Model 968999559

Chassis:	1½" square tube side frame		
Mower Deck:	Made of 11 gauge fabricated welded construction with external reinforcement ribs. Three blades combine for a 42" (107cm) cut width. Cut height approximately 1½" (38mm) to 4" (114 mm).		
Blade Drive:	Electric clutch		
Drive System:	Each rear wheel is independently driven by a Hydro Gear ZT2800 hydrostatic drive with integral charge pump and 7" cooling fan.		
Engine:	20 HP Honda engine, overhead valve, air cooled, gasoline, full pressure lube with oil filter, vertical shaft, aluminum head and block with cast-iron cylinder liners.		
Starting System:	Electric-key switch operation with safety interlocks on park brake and blade drive clutch.		
Tires:	Front	11 x 4.5 x 5 smooth tread	15 PSI (103 kPa)
	Rear	18 X 9.5 X 8 Turf pneumatic	15 PSI (103 kPa)
Capacities:	Fuel	4.9 gallon (19 liters) approximately	
	Engine Oil	2 qts. (1.8 liters) SAE 10W30 with filter	
Dimensions:	Width	44" (112 cm)	
	Height	40" (102 cm)	
	Length	69½" (177 cm)	
	Weight	625 lbs. (283 kg)	

Additional information may be provided elsewhere in this manual.

SPECIFICATIONS SUBJECT TO CHANGE WITHOUT NOTICE

SPECIFICATIONS

RAM MAG SERIES™ 44 Model 968999560

Chassis:	1½" square tube side frame		
Mower Deck:	Made of 11 gauge fabricated welded construction with external reinforcement ribs. Three blades combine for a 42" (107cm) cut width. Cut height approximately 1½" (38mm) to 4" (114 mm).		
Blade Drive:	Electric clutch		
Drive System:	Each rear wheel is independently driven by a Hydro Gear ZT2800 hydrostatic drive with integral charge pump and 7" cooling fan.		
Engine:	20 HP Kohler engine, overhead valve, air cooled, gasoline, full pressure lube with oil filter, vertical shaft, aluminum head and block with cast-iron cylinder liners.		
Starting System:	Electric-key switch operation with safety interlocks on park brake and blade drive clutch.		
Tires:	Front	11 x 4.5 x 5 smooth tread	15 PSI (103 kPa)
	Rear	18 X 9.5 X 8 Turf pneumatic	15 PSI (103 kPa)
Capacities:	Fuel	4.9 gallon (19 liters) approximately	
	Engine Oil	2 qts. (1.8 liters) SAE 10W30 with filter	
Dimensions:	Width	44" (112 cm)	
	Height	40" (102 cm)	
	Length	72" (183 cm)	
	Weight	625 lbs. (283 kg)	

Additional information may be provided elsewhere in this manual.

SPECIFICATIONS SUBJECT TO CHANGE WITHOUT NOTICE

SPECIFICATIONS

RAM MAG SERIES™ 50 Model 968999561

Chassis:	1½" square tube side frame		
Mower Deck:	Made of 11 gauge fabricated welded construction with external reinforcement ribs. Three blades combine for a 48" (122cm) cut width. Cut height approximately 1½" (38mm) to 4" (114 mm).		
Blade Drive:	Electric clutch		
Drive System:	Each rear wheel is independently driven by a Hydro Gear ZT2800 hydrostatic drive with integral charge pump and 7" cooling fan.		
Engine:	21 HP Kawasaki, twin cylinder, overhead valve, air cooled, gasoline, full pressure lube with oil filter, vertical shaft, aluminum head & block with cast-iron cylinder liners with heavy duty canister air cleaner.		
Starting System:	Electric-key switch operation with safety interlocks on park brake and blade drive clutch.		
Tires:	Front	11 x 4.5 x 5 smooth tread	15 PSI (103 kPa)
	Rear	18 X 9.5 X 8 Turf pneumatic	15 PSI (103 kPa)
Capacities:	Fuel	4.9 gallon (19 liters) approximately	
	Engine Oil	2 qts. (1.8 liters) SAE 10W30 with filter	
Dimensions:	Width	50" (127 cm)	
	Height	40" (102 cm)	
	Length	72" (183 cm)	
	Weight	605 lbs. (274 kg)	

Additional information may be provided elsewhere in this manual.

SPECIFICATIONS SUBJECT TO CHANGE WITHOUT NOTICE

SPECIFICATIONS

RAM MAG SERIES™ 50 Model 968999562

Chassis:	1½" square tube side frame		
Mower Deck:	Made of 11 gauge fabricated welded construction with external reinforcement ribs. Three blades combine for a 48" (122cm) cut width. Cut height approximately 1½" (38mm) to 4" (114 mm).		
Blade Drive:	Electric clutch		
Drive System:	Each rear wheel is independently driven by a Hydro Gear ZT2800 hydrostatic drive with integral charge pump and 7" cooling fan.		
Engine:	20 HP Honda, twin cylinder, overhead valve, air cooled, gasoline, full pressure lube with oil filter, vertical shaft, aluminum head & block with cast-iron cylinder liners.		
Starting System:	Electric-key switch operation with safety interlocks on park brake and blade drive clutch.		
Tires:	Front	11 x 4.5 x 5 smooth tread	15 PSI (103 kPa)
	Rear	18 X 9.5 X 8 Turf pneumatic	15 PSI (103 kPa)
Capacities:	Fuel	4.9 gallon (19 liters) approximately	
	Engine Oil	2 qts. (1.8 liters) SAE 10W30 with filter	
Dimensions:	Width	50" (112 cm)	
	Height	40" (102 cm)	
	Length	72" (183 cm)	
	Weight	605 lbs. (274 kg)	

Additional information may be provided elsewhere in this manual.

SPECIFICATIONS SUBJECT TO CHANGE WITHOUT NOTICE

SPECIFICATIONS

RAM MAG SERIES™ 50 Model 968999563

Chassis:	1½" square tube side frame		
Mower Deck:	Made of 11 gauge fabricated welded construction with external reinforcement ribs. Three blades combine for a 48" (122cm) cut width. Cut height approximately 1½" (38mm) to 4½" (114 mm).		
Blade Drive:	Electric clutch		
Drive System:	Each rear wheel is independently driven by a Hydro Gear ZT2800 hydrostatic drive with integral charge pump and 7" cooling fan.		
Engine:	20 HP Kohler, twin cylinder, overhead valve, air cooled, gasoline, full pressure lube with oil filter, vertical shaft, aluminum head & block with cast-iron cylinder liners.		
Starting System:	Electric-key switch operation with safety interlocks on park brake and blade drive clutch.		
Tires:	Front	11 x 4.5 x 5 smooth tread	15 PSI (103 kPa)
	Rear	18 X 9.5 X 8 Turf pneumatic	15 PSI (103 kPa)
Capacities:	Fuel	4.9 gallon (19 liters) approximately	
	Engine Oil	2 qts. (1.8 liters) SAE 10W30 with filter	
Dimensions:	Width	50" (127 cm)	
	Height	40" (102 cm)	
	Length	74½" (189 cm)	
	Weight	605 lbs. (274 kg)	

Additional information may be provided elsewhere in this manual.

SPECIFICATIONS SUBJECT TO CHANGE WITHOUT NOTICE

SEAT ADJUSTMENT INSTRUCTIONS

1. Grasp seat slide adjuster and move it into adjustment position.
2. Slide seat forward or backward.
3. Release seat slide adjuster.

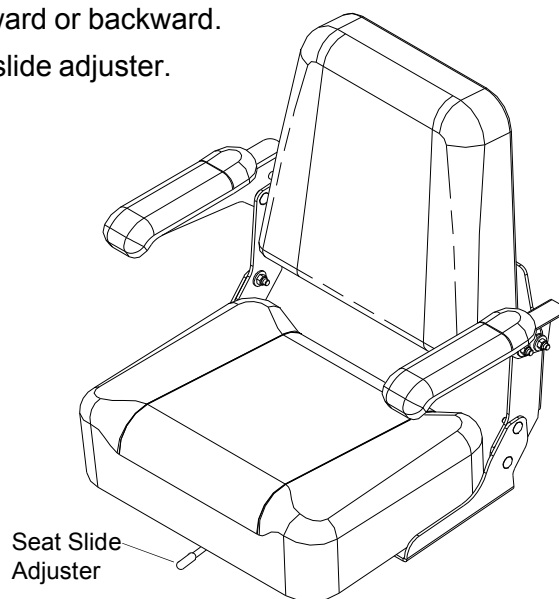

—Fig. 1—

CONTROLS

CONTROL LEVERS

For access to the seat, move control levers to neutral position and swing them outward.

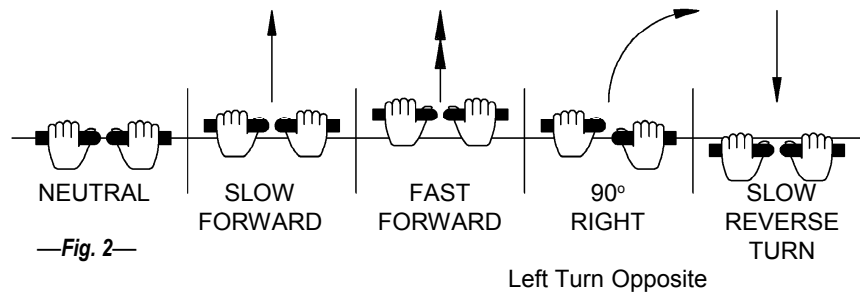

TO GO FORWARD

- From neutral position, gently push control levers forward.
- To increase speed, move levers further forward.

TO GO BACKWARDS

- From neutral position, gently pull control levers toward you.

TURNING

- Turning is controlled by moving one control lever slightly forward or rearward of the other.
- To turn left, move left lever rearward of the right lever.
- To turn right, move right lever rearward of the left lever.
- To turn on mower's own axis (zero turning radius), stop and move one lever to reverse position and the other to forward position.

BRAKING

- To brake mower, move both levers in direction opposite of travel.

NOTE: The pressure required to operate the mower is very light.

CONTROLS

PARK BRAKE

The park brake is designed to hold the mower from moving and is not intended for use in stopping the mower while it is in motion. The engine will stop if the park brake is engaged while the control levers are in the drive position.

	CAUTION Engage park brake before starting engine.
---	--

TO SET PARK BRAKE

The hand-operated park brake is located on the left hand side.

- To engage brake, pull lever up (to the rear).
- To release brake, move lever forward (down).

NOTE: Always set park brake before dismounting.
Release park brake before moving mower.



—Fig. 3—

CONTROLS

BLADE DRIVE

- Located on the control panel, on operator's right.
- To engage the mower blade, pull up on the switch.
- To disengage mower blade, push down.

CHOKE AND THROTTLE CONTROL LEVER

- Located on control panel to operator's right.
- Throttle control for engine speed.
- Choke for engine starting.
- Throttle control should be set to MAXIMUM or wide open setting to insure adequate cooling of the engine and to maintain mower deck blade speed while mowing.

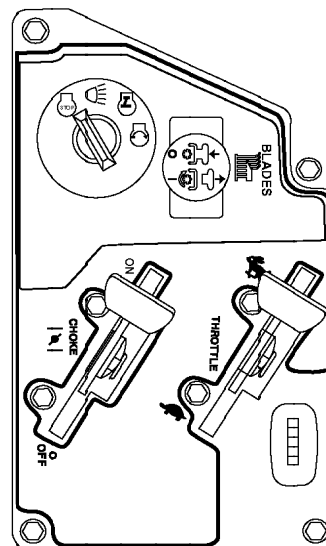

—Fig. 4—

OPERATION INSTRUCTIONS

MOWER DECK CUT HEIGHT LIFT LEVER

- Use right foot to operate deck foot pedal at right front foot area.
- To raise mower deck, push forward with right foot on top portion of foot pedal. When desired deck height is reached, push with right foot on lower portion of foot pedal until the bottom of the foot pedal engages in deck positioning notch.
- To lower deck, push forward with right foot on top portion of foot pedal until bottom edge of foot pedal disengages deck positioning notch. Lower deck to desired height and push bottom portion of foot pedal until bottom edge engages notch.
- Never attempt to operate deck lift mechanism in any manner, other than foot method described above.
- Always use highest position for transport.

OPERATION INSTRUCTIONS

The safe and successful operation of the RAM will depend on the operator having the correct knowledge of all controls used on the mower and making good judgements about the terrain to be mowed.

NEVER allow anyone without complete knowledge of all controls and their functions to operate the mower.

During initial operation, “learning to drive”, set throttle at slow speed.

Sound judgement by the operator will prevent accidents.

BEFORE OPERATING MOWER

1. Read engine manufacturer’s operating and maintenance instructions.
2. Read and observe all safety instructions on your mower and in the manual.
3. Check engine oil.
4. Check fuel cap to be sure it is in place.
5. Be sure park brake is on.
6. Be sure mower blade drive is off.
7. Know how to stop engine. (Turn key to OFF position).

OPERATION INSTRUCTIONS



CAUTION

Failure to observe the following instructions could result in personal injury.

STARTING INSTRUCTIONS

1. Park brake must be on, control levers in outward position and blade drive disengaged.
2. Position throttle to desired speed setting. If engine is cold, position choke lever in the ON position.

NOTE: Engine may require partial choke setting to start even if the engine has been operated for a period of time.

3. Insert ignition key and turn to START position. When engine starts, release ignition key. Key will return to RUN position.
4. Return choke to OFF position, if applicable.
5. Move throttle to maximum speed position.
6. Release park brake.
7. Swing levers inward.
8. Operate mower per CONTROL instructions on Page 25.



CAUTION

Do not operate the engine in an enclosed area due to the harmful exhaust gas produced.

Note: When mowing with blades engaged, set throttle control to the MAXIMUM or wide open setting to insure adequate cooling of the engine and to maintain mower deck blade speed.

OPERATION INSTRUCTIONS

TESTING OF SAFETY INTERLOCK SYSTEMS



WARNING Failure to observe the following instructions could result in serious injury or death.

The following tests should be performed at the start of each mowing day.

PARK BRAKE SWITCH TEST

1. Swing control levers to outward position.
2. Disengage blade drive.
3. Put park brake in OFF position.
4. Turn ignition switch to START.

Engine should not turn over or attempt to start.

CONTROL LEVER SWITCH TEST

1. Disengage blade drive.
2. Put park brake in ON position.
3. Swing control levers inward.
4. Turn ignition switch to START.

Engine should not turn over or attempt to start.

NOTE: If any safety check fails, do not operate the mower until the system has been checked and repaired by an authorized Dixon dealer.

OPERATION INSTRUCTIONS

TESTING OF SAFETY INTERLOCK SYSTEMS



WARNING Failure to observe the following instructions could result in serious injury or death.

The following tests should be performed at the start of each mowing day.

BLADE DRIVE SWITCH TEST

1. Put park brake in ON position.
2. Swing control levers to outward position.
3. Engage blade drive.
4. Turn ignition switch to START.

Engine should not turn over or attempt to start.

SEAT SWITCH TEST

1. In a SAFE AREA away from bystanders, start the engine.
2. Leave control levers in outward position and put park brake ON position.
3. Engage blade drive.
4. Raise slightly off seat. **Engine should stop!**

NOTE: If any safety check fails, do not operate the mower until the system has been checked and repaired by an authorized Dixon dealer.

OPERATION INSTRUCTIONS

MOWING WITH A MULCHING ATTACHMENT

Mulching or recycling the grass clippings requires a totally different mowing approach than would be normal when side discharging or bagging the grass. There may be instances or conditions where it is not possible to hide all the recycled or mulched clippings.

In order to achieve the best results, please read and follow the mulching tips listed below:

1. Read and follow the installation instructions that are included with your mulcher.
2. Set the engine speed control to the wide open or full setting.
3. Place the mower deck cut height selector in either the top or second notch. Never cut more than $\frac{3}{4}$ " (19 mm) to 1" (25mm) off the grass at any one time. Attempting to cut more grass will result in the deck plugging and cause the engine to stall.
4. It may be necessary to cut the lawn twice to achieve acceptable mulching performance especially on first cuttings or if the lawn is heavily fertilized.
5. *Do not attempt to cut grass when it is wet.* Mulching performance will be very poor in wet grass conditions.
6. *Maintain sharp blades throughout the cutting season.* This is very important. Optimal mulching performance cannot be obtained with a dull or nicked blade.

OPERATION INSTRUCTIONS

MOWING WITH A MULCHING ATTACHMENT (continued)

7. *Keep the underside of the mower deck clean.* Remove all grass and dirt buildup from the underside of the pan, the baffles and deflectors after each use. **Never, under any circumstances, should you place hands or feet under the mower deck or in the chute while blades or impeller are still turning.**
8. Alternate mower direction. This will evenly disperse the mulched grass clippings over the lawn for even fertilization.

If the mulching quality of the mower does not seem to be satisfactory, try one or more of the following tips:

- Raise the height-of-cut setting on your mower.
- Cut grass more frequently.
- Operate the mower at a slower ground speed.
- Overlap cutting swaths instead of cutting a full swath with each pass.
- Mow across the marginal areas a second time.
- CUT HIGH - MOW OFTEN!

OPERATION INSTRUCTIONS

MOWING WITH A GRASS CATCHER ATTACHMENT

In order to achieve optimum performance when mowing with a grass catching attachment, please read and follow the tips listed below.

1. Read and follow the installation instructions that are included with your grass catcher.
2. Set engine speed control to the wide open or full setting.
3. *Do not attempt to cut grass when it is wet.* Wet grass will clog both the underside of the deck and the attachment chutes. Empty bags often to prevent plugging.
4. If the grass is tall, place the mower deck cut height selector in the top or second notch. "Initially" overlap cutting swaths instead of a full swath with each pass.
5. *Keep the underside of the mower deck clean.* Frequent removal of dried grass and dirt will greatly assist in bagging of the clippings. **Never, under any circumstances, should you place hands or feet under the mower deck or in the chute while blades or impeller are still turning.**
6. Operate the mower at a slower ground speed than when mowing without a grass catching attachment.

OPERATION INSTRUCTIONS

MOWING WITH A GRASS CATCHER ATTACHMENT (continued)

7. *Maintain sharp blades throughout the cutting season.*
Some grass catching attachments require a “high-lift” blade. See your dealer for advice on the type of blade(s) needed for your mower.
8. Some mowing applications or use of grass catchers may require that an additional weight kit be fitted to the mower to counter the weight of grass in the bags. Please consult with your dealer for more information regarding installation and adding weight to the box.



WARNING Failure to observe the following instructions could result in serious injury or death.

- Watch for low hanging branches or other obstacles that might hit the catcher top while turning or backing the mower.
- Use care when backing to avoid pushing the grass bags into the frame or “hot” exhaust muffler of the engine. Fire could result.
- Disengage blade and stop engine prior to clearing grass from either the discharge chute or grass catcher components.
- Do not operate the mower with the grass catching attachment partially removed. Operator or bystanders could be injured by thrown objects.
- Keep all attachment bolts tight.
- *Important: Do not leave clippings in the bags while the mower is stored.* Damp grass clippings are a fire hazard if left in the bag.

OPERATION INSTRUCTIONS

SIDE DISCHARGE OF THE CLIPPINGS

In order to achieve optimum performance when side discharging the grass clippings, please read and follow the tips listed below. Additional information can be found in the Troubleshooting guide on Page 48-49.



CAUTION

To avoid personal injury, be sure that the deflector is properly installed on the discharge chute.

1. Set engine speed control to the wide open or full setting.
2. *Do not attempt to cut grass when it is wet.* Wet grass will clog the underside of the deck and discharge area.
3. If the grass is tall, place the mower deck cut height lever in the top or second notch. “Initially” overlap cutting swaths instead of a full swath with each pass. Some applications may require a second cutting.
4. *Keep the underside of the mower deck clean.* Frequent removal of dried grass and dirt will allow the clippings to discharge correctly. **Never, under any circumstances, place your hands or feet under the mower deck or in the chute while blades or impeller are still turning.**
5. Maintain sharp blade(s) throughout the cutting season.

OPERATION INSTRUCTIONS

GRASS HEIGHT AND CUTTING SUGGESTIONS

Do not attempt to cut grass when it is wet.

If the grass is tall, place the mower deck cut height lever in the top or second notch. "Initially" overlap cutting swaths instead of a full swath with each pass. Some applications may require a second cutting.

Keep the underside of the mower deck clean.

Maintain sharp blades throughout the cutting season.

As a rule of thumb, never cut off more than one third of the total grass blade length. Correct mowing height can reduce weeds and disease by 50% to 80%.

The following grass cut heights are based on adequate moisture conditions and normal thatch buildup in a healthy lawn. Some locations and applications may require slightly different cut heights. If in doubt, consult your local lawn professional for assistance.

<u>Grass Types</u>	<u>Best Cut Heights</u>
Bermudagrass	1 - 2" (25-51 mm)
Bluegrass	2 - 3" (51-76 mm)
Buffalograss	1½ -3" (38-76 mm)
Ryegrass	2 - 3" (51-76 mm)
Tall Fescue	3-3½" (76-89 mm)
Zoysiagrass	1 - 3" (25-76 mm)

OPERATION INSTRUCTIONS

TOWING TRAILERS AND OTHER ATTACHMENTS

Towing a trailer or other attachment that is too heavy could damage the drive or cause the mower to become unstable. Limit loads to 250 pounds (113 kg) or less with this mower.

To Free Wheel Machine (Unlock Transmission)

When pushing or pulling the mower, be sure to engage the hydro release levers. Always turn off engine before engaging or disengaging the hydro release (free wheel) lever. Never attempt to move the lever with the engine running.

- Raise the deck to the highest cutting position.
- Pull the bypass lever out and into the slots so that it is held in the bypass position.
- To reengage to drive, reverse the above procedure.

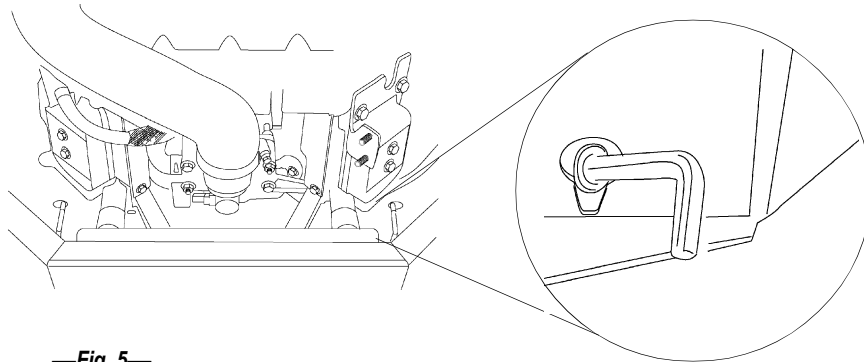

—Fig. 5—

Hydro Release Lever
with the head outside the
rear deck—bypass position

NOTE: Before pushing or towing tractor, transmission must be unlocked and park brake released. The tractor should never be pulled at more than 2 miles per hour (3.2 km/h) or for distances over $\frac{1}{4}$ mile (.402 km). Trailer the unit for distances over $\frac{1}{4}$ mile.

CARE AND MAINTENANCE

 CAUTION Failure to observe the following instructions could result in personal injury.

*Before performing any maintenance, turn off engine, allow to cool and remove key.
Use extreme care when working on machinery.
Do not wear watch or jewelry.
Do not wear loose fitting clothes, and observe all common safety practices with tools.*

MAINTENANCE SCHEDULE

- Check deck belt after 20 hours break-in
- Check crankcase oil level before each use
- Clean grass & debris from muffler & manifold area before each use
- Check air intake screen after each use
- Clean grass under deck. after each use
- Check tire pressure every 10 hours
- Inspect blades for sharpness every 10 hours
- Clean air filter element. every 25 hours
- Grease all zerks every 50 hours
- Check all belts every 50 hours
- Change engine crankcase oil & filter (5 hours break-in) and every 50 hours
- Change engine oil filter every 50 hours
- Replace air filter element annually or every 100 hours

CARE AND MAINTENANCE



CAUTION

Stop engine and remove ignition key for safety. Wear heavy, thick gloves when holding onto cutter blade, avoid the sharp edge of the blade.

CUTTER BLADE MAINTENANCE

Check sharpness of mower blades after every 10 hours of operation. Observe proper blade position prior to removal.

1. Safely raise front of mower.
2. Hold or block blade from turning.
3. Loosen blade bolt and remove blade.
4. When replacing blade, tighten blade bolt securely. Refer to Fig 6. Tighten blade bolt to 60 ft. lbs. (81Nm)

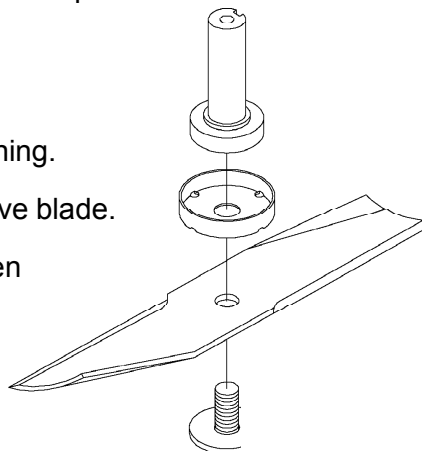

—Fig. 6—

Blades should be discarded when worn excessively.

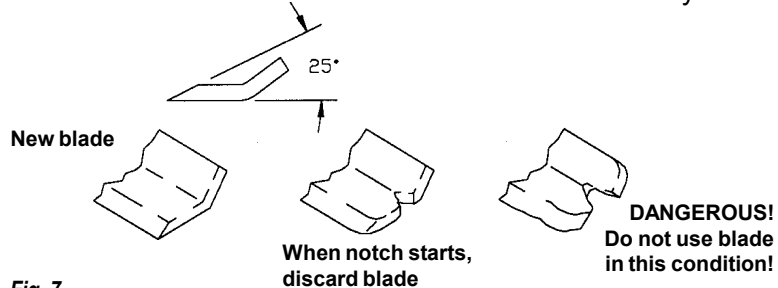

—Fig. 7—

CARE AND MAINTENANCE

BELTS

Check belts every 100 hours. Replace any belts showing signs of severe cracking or large nicks. Belts are not adjustable, replace if they begin to slip from wear.

ENGINE

For complete maintenance and operating information of the engine, please refer to the maintenance instructions furnished by the engine manufacturer and included in your Zero Turn Radius mower information packet.



CAUTION

Battery contains sulfuric acid electrolyte that is poisonous and corrosive.

BATTERY

This is a maintenance-free battery and the fluid level cannot be checked. Charge battery if required.

OFF SEASON BATTERY STORAGE

- DO NOT remove battery from mower.
- Clean top of battery and terminals with baking soda and water.
- Identify each cable so they can be reconnected to the correct terminal.
- Disconnect cables from terminals. ALWAYS disconnect ground cable first and reconnect last.
- Charge battery.

NOTE: Your Dixon mower comes equipped with a quick disconnect harness for the optional Dixon Battery Manager. The Dixon Battery Manager maintains the proper charge levels during periods of inactivity and may prevent premature battery failures. Contact your dealer for more information.

CARE AND MAINTENANCE

TIRES

Correct tire pressure is essential for efficient operation of the mower. Check tire pressure periodically. Inflate tires to the pressure listed below.

Front tires	11 x 4.50 - 5	15 PSI	(103 kPa)
Rear tires	18 x 9.50 - 8	15 PSI	(103 kPa)

Lug nuts or lug bolts should be checked regularly for tightness.

LUBRICATION

CHASSIS:	(11) grease zerks
LOCATIONS:	(2) front wheels (1) mower deck hubs
SERVICE INTERVALS:	Every 50 hours of operation or once per season
RECOMMENDED GREASE:	Name brand wheel bearing or multipurpose grease (3 pumps each)

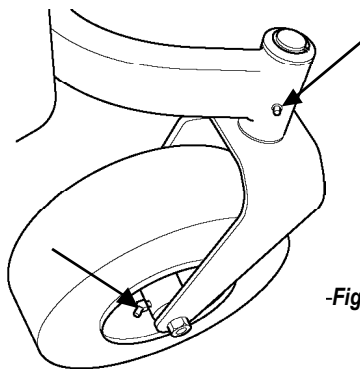

-Fig. 8-

CARE AND MAINTENANCE



CAUTION

HOT oil may cause burns. Allow engine to cool before draining oil.

CHANGING THE ENGINE OIL

1. The “Dapco” oil drain valve is located on the left side of the engine crankcase.
2. Place a suitable container under the drain valve hose.
3. To drain, turn hex head valve stem counter-clockwise with a 10mm wrench or socket. Open to full open (approximately 7 turns).
4. After engine is drained, tighten hex stem.
5. Change oil filter.
6. Fill with oil (see steps below).

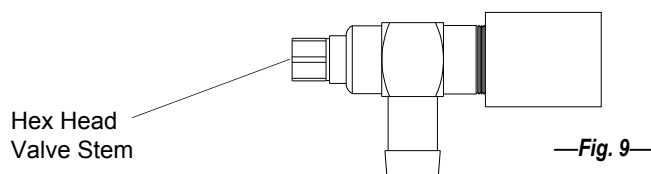

NOTE: Refer to engine manufacturer's recommendations for frequency of oil changes.

OIL FILL

1. Clean any spilled oil from engine and chassis.
2. Refill engine with type, and quantity of oil recommended by the engine manufacturer in engine literature.

NOTE: Engine oil changes on the Ram Series will require replacement of the oil filter. These filters may be available from your local Dixon Dealer.

CARE AND MAINTENANCE

TRACKING ADJUSTMENT

If the mower is not tracking straight, check the air pressure in both rear tires. Recommended air pressure is 15 PSI (1 bar). If the unit will not track straight, follow the steps below. Tracking must be checked on a flat and level concrete or blacktop surface.

Mower is tracking to the right.

Increase the air pressure 2-3 PSI (0.1-0.2 bar) in the right rear tire or decrease the air pressure 2/3 PSI in the left rear tire.

Mower is tracking to the left.

Increase the air pressure 2-3 PSI (0.1-0.2 bar) in the left rear tire or decrease the air pressure 2/3 PSI in the right rear tire. Recheck tracking and keep making adjustments with the tire pressure until the unit tracks straight. DO NOT exceed maximum recommended tire pressure 24 PSI (1.6 bar). Record the tire pressure for future reference.

NOTE: If the above procedure fails, have the mower checked and repaired by an authorized Dixon dealer.

CARE AND MAINTENANCE

MOWER DECK LEVELING PROCEDURE

There are four (4) slots that will control the attitude or pitch of the mower deck. The deck should be level or pitched slightly higher in rear.

1. Place the mower on a smooth level surface with front casters positioned towards deck. Check tire pressures to insure the mower has a correct stance. Inflate tires as required:

Front 16 - 21 lbs maximum (110-145 kPa)

Rear: 8-14 lbs maximum (55-97 kPa)

NOTE: To insure accuracy of leveling procedure, mower deck drive belt must be installed prior to leveling deck.

2. Wear heavy gloves. Turn each outer blade tip to align with the deck or in a side-to-side manner.
3. Measure from the floor surface up to the bottom of the blade tip on the discharge side of the mower. Retain this measurement. Move to the opposite side and check to see if that measurement is the same. If adjustment is required, turn nut on one or both of the front L-rods until both measurements are equal.
4. Turn each outer blade tip to align with the deck in a front to rear manner.
5. Measure from the floor surface up to the bottom of the blade tips at both the front and rear of the blades. Rear of blade tips should be $\frac{1}{8}$ " to $\frac{1}{4}$ " higher than the front of blade tips. If adjustment is required, turn nut on one or both of the rear L-rods until both measurements are equal.

NOTE: This will place the mower deck in a base measurement position. Additional adjustment may be required to achieve desired cut for the type of grass or conditions involved.

CARE AND MAINTENANCE

ELECTRICAL SYSTEMS

Keep all connections clean and tight.

CLEANING THE MOWER

Wash mower periodically. Clean above and below deck.

High pressure washing and alkaline based soaps can cause damage to bearings and other parts of the mower. After washing your mower, start the engine and engage the mower deck for a few minutes to disperse any water that may have accumulated in bearings, pulleys or fans.

Note: Allow mower to cool before washing. If bearings are hot, they will draw moisture inside as they dry and cause corrosion.

SERIAL NUMBERS

The serial number is located on frame at rear of engine.

WARRANTY

Refer to warranty information (Page 16).

PARTS/SERVICE

See your Dixon dealer for replacement parts, warranty or service.

TROUBLESHOOTING

1. ENGINE WON'T TURN OVER

Mower blades engaged ----- *disengage blades*
Park brake not on----- *engage park brake*
Dead battery ----- *charge or replace*
Solenoid ----- *consult dealer*
Ignition switch ----- *consult dealer*
Starter ----- *consult dealer*

2. ENGINE WILL TURN OVER BUT WON'T START

No fuel ----- *refuel and/or clean or replace fuel filters*

3. HARD TO START ENGINE

Fuel line clogged ----- *clean fuel line and check fuel filter*
Faulty fuel pump----- *consult dealer*

4. ENGINE STARTS BUT CUTS OUT

Water in fuel ----- *drain old fuel-replace with new fuel*
Clogged fuel line ----- *check fuel filter*
Fuel tank vent plugged ----- *clean fuel vent*
Faulty fuel pump ----- *consult dealer*

5. ENGINE OVERHEATED

Air intake screen or fins clogged ----- *clean intake screen and fins*
Oil level too low or too high ----- *adjust oil level*
Running engine too slow----- *run engine faster*

TROUBLESHOOTING

6. ENGINE RUNS BUT MOWER WON'T MOVE FORWARD

Drive belt broken or slipping ----- *replace drive belt*

Transmission oil low ----- *add oil*

Damaged transmission ----- *consult dealer*

Transmission bypass may be engaged ---- *disengage (see page 37)*

7. MOWER LOSES POWER OR TRANSMISSION OVERHEATS

Engine air filter ----- *clean or replace*

Transmission damage ----- *consult dealer*

8. ENGINE STALLS WHEN BLADES ARE ENGAGED

Operator not on seat ----- *sit on seat*

Faulty interlock system ----- *consult dealer*

Faulty blade spindle bearing ----- *consult dealer*

Deck drive belt not properly routed ----- *reroute*

Blades blocked by foreign material ----- *clean under deck*

9. DRIVE SYSTEM

Mower pulls to side ----- *check tire inflation/consult dealer*

Mower creeps in neutral ----- *consult dealer*

Low on power ----- *check belt tension*

10. CUT QUALITY

Cut uneven left to right ----- *check tire inflation/level deck*

Ends of grass blades are ragged ----- *sharpen blades*

Poor dispersal of grass ----- *clean deck/check for loose belt*

Skips in spots ----- *check for loose belt/slow ground speed*

STANDARD SERVICE PARTS LIST

BLADES

44" Deck

* Hi Lift Fusion	P/N 539 119836
Super Hi-Lift Fusion	P/N 539 119798
Standard Lift Fusion	P/N 539 119860
Gator Fusion	P/N 539 119862
Hi-Lift	P/N 539 119858
Standard Lift	P/N 539 119859

50" Deck

* Hi Lift Fusion	P/N 539 119837
Super Hi-Lift Fusion	P/N 539 119799
Standard Lift Fusion	P/N 539 119865
Gator Fusion	P/N 539 119867
Hi-Lift	P/N 539 119863
Standard Lift	P/N 539 119864

* Factory installed

BELTS

44" Deck

Engine to Mower Deck	P/N 539 114543
Engine to Transmission	P/N 539 104334

50" Deck

Engine to Mower Deck	P/N 539 114508
Engine to Transmission	P/N 539 104334

ENGINE AIR AND OIL FILTERS

Refer to Engine Operator's Manual for correct service intervals for engine oil changes and air filter maintenance.

Protect your engine investment, use only original equipment filters. Refer to the Engine Operator's Manual or ask your dealer for correct replacement parts.



OWNER'S INFORMATION

Date of Purchase _____

Mower Model Number _____

Mower Serial Number _____

Purchased From _____

DATE OIL CHANGED

DATE ENGINE TUNED

DIXON ZTR®

Dixon and ZTR®
are registered trademarks
of Dixon



WARNING

The engine exhaust from this product contains chemicals known to the State of California to cause cancer, birth defects or other reproductive harm.

DIXON
401 Commerce Street
Beatrice, NE 68310

Ram Series
Part No. 539 114246IR