

DIXON ZTR

Operator Manual

SPEEDZTR 44 / 965981001 SPEEDZTR 46 / 965882001
SPEEDZTR 54 / 965882101 SPEEDZTR 36 / 965882201
SPEEDZTR 44 / 965882301 SPEEDZTR 48 / 965882401

Please read the operator's manual carefully and make sure you understand the instructions before using the machine.

In order to implement improvements, specifications and designs can be altered without prior notification.

Note that no legal demands can be placed based on the information contained in these instructions.

Use only original parts for repairs. The use of other parts voids the warranty.

Do not modify or install non-standard equipment to the unit without consent from the manufacturer. Modifications to the unit may cause unsafe operations or damage the unit.

TABLE OF CONTENTS

INTRODUCTION.....	5	Air Filter	39
Driving and Transport on Public Roads.....	5	Kawasaki Engine.....	39
Towing	5	Kohler Engine.....	40
Operating.....	5	Briggs & Stratton Engine - 19 HP.....	41
Good Service.....	6	Briggs & Stratton Engine - 22 HP.....	43
SYMBOLS AND DECALS	7	Fuel Filter	44
SAFETY.....	9	Fuel Pump Air Filter.....	44
Safety Instructions.....	9	Tire Pressures	44
Personal Safety Equipment.....	11	Parking Brake.....	45
Slope Operation	11	V-belts	45
Safe Handling of Gasoline.....	13	Deck Belt.....	45
General Maintenance.....	14	Pump Belt.....	46
Transport	16	Cutting Blades.....	47
CONTROLS.....	17	Blade replacement	47
Control Locations	17	Adjusting the Mower Deck.....	48
Motion Control Levers	18	Deck Leveling.....	48
Seat Adjustment Lever	19	Anti-scalp rollers.....	49
Bypass Linkage.....	19	Caster Wheels.....	49
Fuel Tank.....	20	Hardware.....	49
Ignition Switch.....	21	Cleaning	50
Choke Control	21	Lubrication Schedule.....	51
Blade Switch.....	22	LUBRICATION.....	51
Parking Brake.....	22	Front Wheel Mount.....	52
Cutting Height Adjuster.....	22	Front Wheel Bearings.....	52
Fuses.....	23	Deck Spindle	52
Fuel Shut Off Valve.....	23	Deck Outer Spindle	52
OPERATION.....	24	Engine Oil.....	53
Training.....	24	Engine Oil Levels	53
Steering	24	Changing the Engine Oil	54
Before Starting	25	Cables	54
Starting the Engine.....	25	TROUBLE SHOOTING	55
Weak Battery.....	28	STORAGE	57
Jumper Cables	28	Winter Storage	57
Running	29	Service	57
Operating On Hills	30	SCHEMATIC.....	58
Mowing Tips	31	TECHNICAL DATA	59
Stopping the Engine.....	32	Accessories	59
Manual Transport	33	Torque Specifications	59
MAINTENANCE	34	CONFORMITY CERTIFICATES.....	66
Maintenance Schedule.....	34	WARRANTY	67
Battery.....	36	SERVICE JOURNAL	68
Ignition System.....	37	Delivery Service	68
Safety System	37	After the First 5-8 Hours	69
Engine Cooling Air Intake	38	25-Hour Service	70
Throttle Cable.....	38	50-Hour Service	71
Choke Cable.....	38	100-Hour Service	72
		300-Hour Service	73
		At Least Once Each Year	74



WARNING!

Failure to follow cautious operating practices can result in serious injury to the operator or other persons. The owner must understand these instructions, and must allow only trained persons who understand these instructions to operate the mower.

Each person operating the mower must be of sound mind and body and must not be under the influence of any mind altering substance.



WARNING!

Engine exhaust, some of its constituents, and certain vehicle components contain or emit chemicals known to the State of California to cause cancer and birth defects or other reproductive harm.



WARNING!

Battery posts, terminals and related accessories contain lead and lead compounds, chemicals known to the State of California to cause cancer and birth defects or other reproductive harm. Wash hands after handling.

INTRODUCTION

Congratulations

Thank you for purchasing a Dixon ride-on mower. This machine is built for superior efficiency to rapidly mow primarily large areas. A control panel easily accessible to the operator and a hydrostatic transmission regulated by steering controls both contribute to the machine's performance.

This manual is a valuable document. Read the contents carefully before using or servicing the machine. The following of instructions (use, service, maintenance, etc.) by all who operate this machine is important for the safety of the operator and others. It can also considerably increase the life span of the machine and increase its resale value.

If you sell your machine, be sure to give the operator's manual to the new owner.

The final chapter of this operator's manual provides a Service Journal. Ensure that service and repair work are documented. A well-kept service journal reduces service costs for the maintenance and affects the machine's resale value. Please contact your dealer for more information. Take the operator's manual along when the machine is taken to your dealer for service.

General

In this operator's manual, left and right, backward and forward are used in relation to the machine's normal driving direction.

Continuous dedication to improve our products require that specifications and design are subject to change without notice.

Driving and Transport on Public Roads

Check applicable road traffic regulations before transporting on public roads. If the machine is transported, you must always use approved fastening equipment and ensure that the machine is well anchored. DO NOT operate this machine on public roadways.

Towing

If machine is equipped with a tow hitch, use extreme caution when towing. Never allow children or others in or on the towed equipment. Make wide turns to avoid jack-knifing. Travel slowly and allow extra distance to stop.

Do not tow on sloped ground. The weight of the towed equipment may cause loss of traction and loss of control.

Follow the manufacturer's recommendation for weight limits for towed equipment. Do not tow near ditches, canals, and other hazards.

Operating

This machine is constructed only for mowing grass on lawns and even ground without obstacles such as stones, tree stumps, etc. The machine can also be used for other tasks when equipped with special accessories provided by the manufacturer. Operating instructions for the accessories are provided with delivery. All other types of uses are incorrect. The manufacturer's directions concerning operation, maintenance, and repairs must be carefully followed.

Lawn mowers and all power equipment, can be potentially dangerous if used improperly. Safety requires good judgement, careful use in accordance with these instructions and common sense.

The machine must only be operated, maintained, and repaired by persons familiar with the machine's special characteristics and who are also knowledgeable about the safety instructions. Use only approved repair parts to maintain this machine.

Accident prevention regulations, other general safety regulations, occupational safety rules, and traffic regulations must be followed without fail.

Unauthorized modifications to the design of the machine may absolve the manufacturer from liability for any resulting personal injury or property damage.

INTRODUCTION

Good Service

Dixon's products are sold only in specialized retail stores with complete service. This ensures that you as a customer receive only the best support and service. Before the product is delivered, the machine has, for example, been inspected and adjusted by your retailer. See the certificate in the Service Journal in this operator's manual.

When you need spare parts or support in service questions, warranty issues, etc., please consult the following professional:

This Operator's Manual belongs to the machine with the manufacturing number:	Engine	Transmission

Manufacturing Number

The machine's manufacturing number can be found on the printed plate affixed to the right in the engine compartment. Stated on the plate, from the top are:

- The machine's type designation (I.D.).
- The manufacturer's type number (Model).
- The machine's serial number (Serial no.)

Please have the type designation and serial number available when ordering spare parts.

The engine's manufacturing number is stamped on one of the valve covers.

The plate states:

- The engine's model.
- The engine's type.
- Code

Please have these available when ordering spare parts.

SYMBOLS AND DECALS

These symbols are found on the machine and in the operator's manual. Study them carefully so that you know what they mean.

	<p>WARNING!</p> <p>Xxxx xxxxxx xxxxxx xxxx xxxxxxxxxxx xxxxxx xxxxxxxxxxx. xx xxxxxxxxxxx xxxx xxxxxx.</p>
---	---

Used in this publication to notify the reader of a risk of **personal injury or death**, particularly if the reader should neglect to follow instructions given in the manual.

<p>IMPORTANT INFORMATION</p> <p>Xxxx xxxxxx xxxxxx xxxx xxxxxxxxxxx xxxxxx xxxxxxxxxxx. xx xxxxxxxxxxx xxxx xxxxxx.</p>

Used in this publication to notify the reader of a risk of **material damage**, particularly if the reader should neglect to follow instructions given in the manual. Used also when there is a potential for misuse or misassembly.

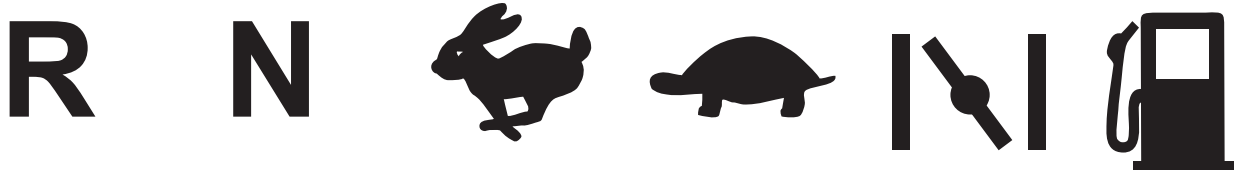

Reverse Neutral Fast Slow Choke Fuel



Warning! Parking Brake CE conformity marking. Only for European market Warning! Rotating blades, keep away from the discharge deck Do not touch parts



Battery acid is corrosive, explosive and flammable Do not stand here Noise emissions to the surroundings in accordance with the European Union's directive. The machine's emission is stated in the chapter TECHNICAL DATA and on the decals.

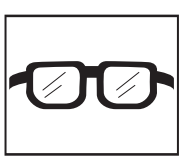

Use protective glasses



Use protective gloves

Noise emissions to the surroundings in accordance with the European Union's directive. The machine's emission is stated in the chapter TECHNICAL DATA and on the decals.

Only machines for European market

SYMBOLS AND DECALS

Read
Operator's
Manual

Shut off engine and
remove key before
performing any
maintenance or repair work

Keep a safe
distance from
the machine

Use on slopes
no greater
than 10°

No passengers

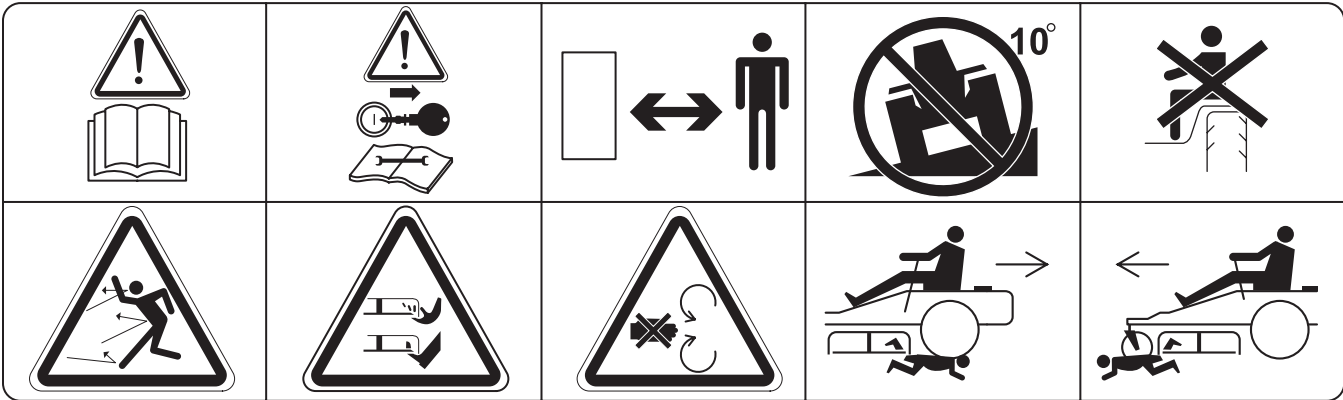

Whole body
exposure to
thrown objects

Severing of fingers
and toes

Do not open or
remove safety
shields while
engine is running

Careful backing up,
watch for other
people

Careful going
forward, watch for
other people



Moving sharp blades under cover

SAFETY

Safety Instructions

These instructions are for your safety. Read them carefully.



WARNING!

This symbol means that important safety instructions need to be emphasized. It concerns your safety.

IMPORTANT: THIS CUTTING MACHINE IS CAPABLE OF AMPUTATING HANDS AND FEET AND THROWING OBJECTS. FAILURE TO OBSERVE THE FOLLOWING SAFETY INSTRUCTIONS COULD RESULT IN SERIOUS INJURY OR DEATH.

General Operation

- Read, understand, and follow all instructions on the machine and in the manual before starting.
- Do not put hands or feet near rotating parts or under the machine. Keep clear of the discharge opening at all times.
- Only allow responsible adults, who are familiar with the instructions, to operate the machine.
- Clear the area of objects such as rocks, toys, wire, etc., which could be picked up and thrown by the blades.
- Be sure the area is clear of bystanders before operating. Stop machine if anyone enters the area.
- Never carry passengers. The machine is only intended for use by one person.
- Do not mow in reverse unless absolutely necessary. Always look down and behind before and while backing.
- Never direct discharged material toward anyone. Avoid discharging material against a wall or obstruction. Material may ricochet back toward the operator. Stop the blades when crossing gravel surfaces.
- Do not operate machine without the entire grass catcher, discharge guard, or other safety devices in place and working
- Slow down before turning.
- Never leave a running machine unattended. Always turn off blades, set parking brake, stop engine, and remove keys before dismounting.
- Disengage blades when not mowing. Shut off engine and wait for all parts to come to a complete stop before cleaning the machine, removing the grass catcher, or unclogging the discharge guard.
- Operate machine only in daylight or good artificial light.
- Do not operate the machine while under the influence of alcohol or drugs.

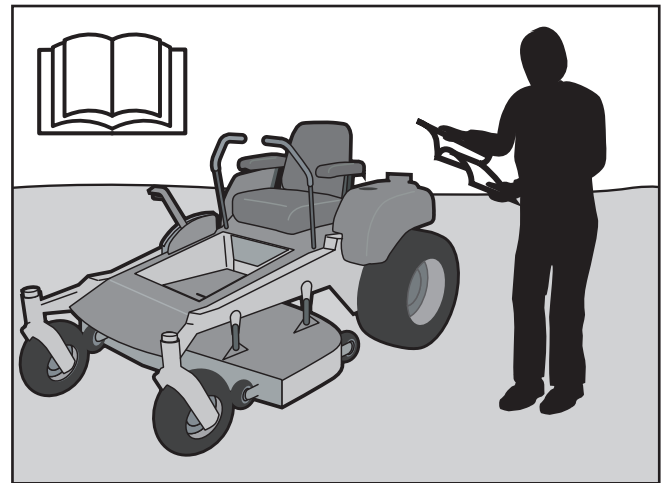

8011-512

Read the operator's manual before starting the machine

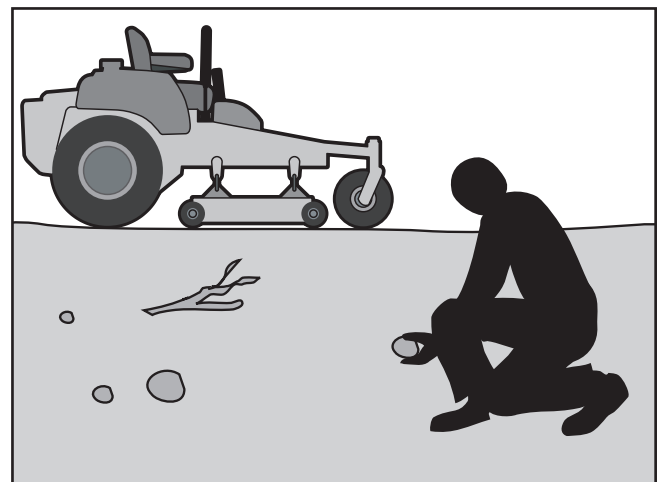

8011-513

Clear the area of objects before mowing

SAFETY

- Watch for traffic when operating near or crossing roadways.
- Use extra care when loading or unloading the machine into a trailer or truck.
- Always wear eye protection when operating machine.
- Data indicates that operators age 60 years and above are involved in a large percentage of riding mower-related injuries. These operators should evaluate their ability to operate the riding mower safely enough to protect themselves and others from serious injury.
- Follow the manufacturer's recommendation for wheel weights or counterweights.
- Anyone who operates this machine must first read and understand this Operation Manual. Local laws may regulate the age of the user.
- Keep machine free of grass, leaves or other debris buildup which can touch the hot exhaust or engine parts and burn. Do not allow the mower deck to plow leaves or other debris, causing buildup to occur.
- Clean any oil or fuel spillage before operating or storing the machine.
- Allow machine to cool before storage.



8011-520

Never take passengers



WARNING!

Engine exhaust and certain vehicle components contain or emit chemicals considered to cause cancer, birth defects, or other reproductive system damage. The engine exhaust contains carbon monoxide, which is a odorless, colorless, poisonous gas. Do not use the machine in enclosed spaces.

SAFETY

Personal Safety Equipment



WARNING!

When using the machine, approved personal protective equipment (shown in illustrations) shall be used. Personal protective equipment cannot eliminate the risk of injury but it will reduce the degree of injury if an accident does happen. Ask your retailer for help in choosing the right equipment.

- Make sure that you have first aid equipment close at hand when using the machine.
- Never use the machine when barefoot.
- Always wear protective shoes or boots, preferably with steel toe caps.
- Always wear approved protective glasses or a full visor when assembling or driving.
- Always wear gloves when handling the blades.
- Never wear loose clothing that can get caught in moving parts.
- Use ear protectors to avoid damage to hearing.

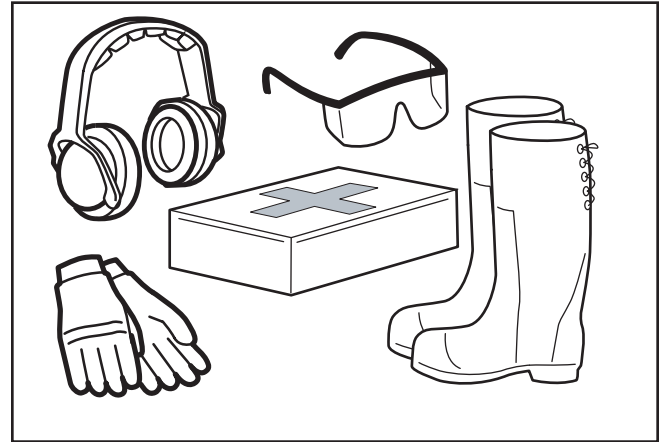

8011-670a

Personal protective equipment

Slope Operation

Slopes are a major factor related to loss of control and tip-over accidents, which can result in severe injury or death. Operation on all slopes requires extra caution. If you cannot back up the slope or if you feel uneasy on it, do not mow it.

- Mow up and down slopes (10 degrees maximum), not across.
- Watch for holes, ruts, bumps, rocks, or other hidden objects. Uneven terrain could overturn the machine. Tall grass can hide obstacles.
- Choose a low ground speed so that you will not have to stop while on the slope.
- Do not mow on wet grass. Tires may lose traction.
- Avoid starting, stopping, or turning on a slope. If the tires lose traction, disengage the blades and proceed slowly straight down the slope.
- Keep movement on the slopes slow and gradual. Do not make sudden changes in speed or direction, which could cause machine to roll over.
- Use extra care while operating machine with grass catchers or other attachments; they can affect the stability of the machine.
- Do not use on steep slopes.
- Do not try to stabilize the machine by putting a foot on the ground.
- Do not mow near drop-offs, ditches, or embankments. The machine could suddenly roll over if a wheel is over the edge or if the edge caves in.

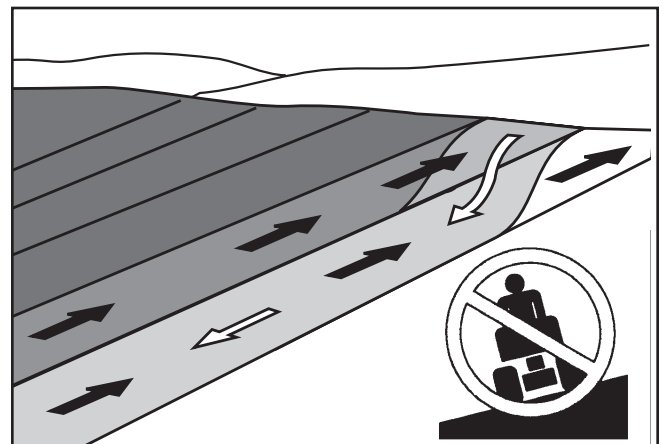

6003-004

Mow up and down, not side to side



WARNING!

Do not drive up or down hills with slopes greater than 10 degrees. And do not drive across any slopes.

SAFETY

Children

Tragic accidents can occur if the operator is not alert to the presence of children. Children are often attracted to the machine and the mowing activity. *Never* assume that children will remain where you last saw them.

- Keep children out of the mowing area and in the watchful care of a responsible adult other than the operator.
- Be alert and turn machine off if a child enters the area.
- Before and while backing, look behind and down for small children.
- Never carry children, even with the blades shut off. They may fall off and be seriously injured or interfere with safe machine operation. Children who have been given rides in the past may suddenly appear in the mowing area for another ride and be run over or backed over by the machine.
- Never allow children to operate the machine.
- Use extra care when approaching blind corners, shrubs, trees, or other objects that may block your view of a child.

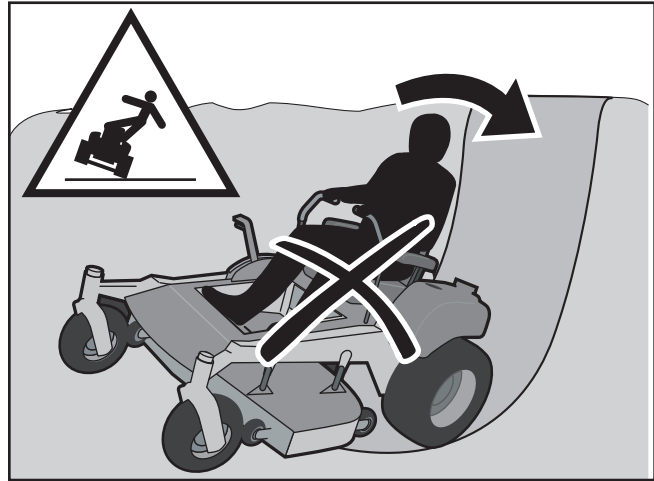

8011-509

Be extra cautious when driving on slopes

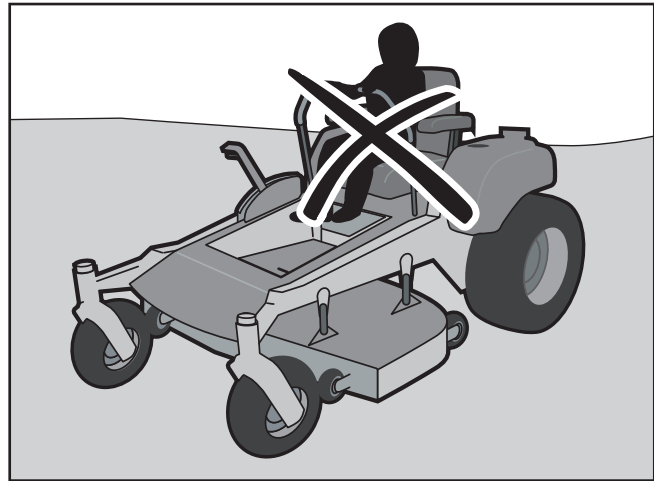

8011-517

Never allow children to operate the machine



8011-518

Keep children away from work area

SAFETY



WARNING!

The engine must not be started when the driver's floor plate or any protective plate for the mower deck's drive belt is removed.

Safe Handling of Gasoline

To avoid personal injury or property damage, use extreme care in handling gasoline. Gasoline is extremely flammable and the vapors are explosive.

- Extinguish all cigarettes, cigars, pipes, and other sources of ignition.
- Use only approved gasoline container.
- Never remove gas cap or add fuel with the engine running. Allow engine to cool at least two (2) minutes before refueling.
- Never fuel the machine indoors.
- Never store the machine or fuel container where there is an open flame, spark, or pilot light such as on a water heater or other appliance.
- Before you begin refueling, minimize the risk of static electricity by touching a metal surface.
- Never fill containers inside a vehicle or on a truck or trailer bed with plastic liner. Always place containers on the ground away from the vehicle when filling.
- Remove gas-powered equipment from the truck or trailer and refuel it on the ground. If this is not possible, refuel such equipment with a portable container, rather than from a gasoline dispenser nozzle.
- Keep the nozzle in contact with the rim of the fuel tank or container opening at all times until fueling is complete. Do not use a nozzle lock-open device.
- If fuel is spilled on clothing, change clothing immediately.
- Never overfill fuel tank. Replace gas cap and tighten securely.
- Do not start the engine near spilled fuel.
- Never use gasoline as a cleaning agent.
- If leaks arise in fuel system, engine must not be started until problem has been resolved.
- Check the fuel level before each use and leave space for the fuel to expand, as the heat from the engine and the sun may otherwise cause the fuel to expand and overflow.



Never fill the fuel tank indoors

8011-516



WARNING!

The engine and the exhaust system become very hot during operation.

There is risk for burns if touched.

Allow engine and exhaust system to cool at least two (2) minutes before refueling.

SAFETY

General Maintenance

- Never operate machine in a closed area.
- Keep all nuts and bolts tight to be sure the equipment is in safe working condition.
- Never tamper with safety devices. Check their proper operation regularly.
- Keep machine free of grass, leaves, or other debris buildup. Clean oil or fuel spillage and remove any fuel-soaked debris. Allow machine to cool before storing.
- If you strike a foreign object, stop and inspect the machine. Repair, if necessary, before restarting.
- Never make any adjustments or repairs with the engine running.
- Check grass catcher components and the discharge guard frequently and replace with manufacturer's recommended parts, when necessary.
- Mower blades are sharp. Wrap the blade or wear gloves, and use extra caution when servicing them.
- Check brake operation frequently. Adjust and service as required.
- Maintain or replace safety and instruction labels, as necessary.
- Do not modify safety equipment. Check regularly to be sure it works properly. The machine must not be driven with defective or unmounted protective plates, protective cowlings, safety switches, or other protective devices.
- Do not change the settings of governors and avoid running the engine with overly high engine speeds. If you run the engine too fast, you risk damaging the machine components.
- Be very careful when handling battery acid. Acid on skin can cause serious corrosive burns. If you spill battery acid on your skin, rinse immediately with water.
- Acid in the eyes can cause blindness, contact a doctor immediately.
- Be careful when servicing the battery. Explosive gases form in the battery. Never perform maintenance on the battery when smoking or near open flames or sparks.
- The battery can explode and cause serious injury or damage.
- Ensure that nuts and bolts, especially the fastening bolts for the blade attachments, are properly tightened, torqued and that the equipment is in good condition.

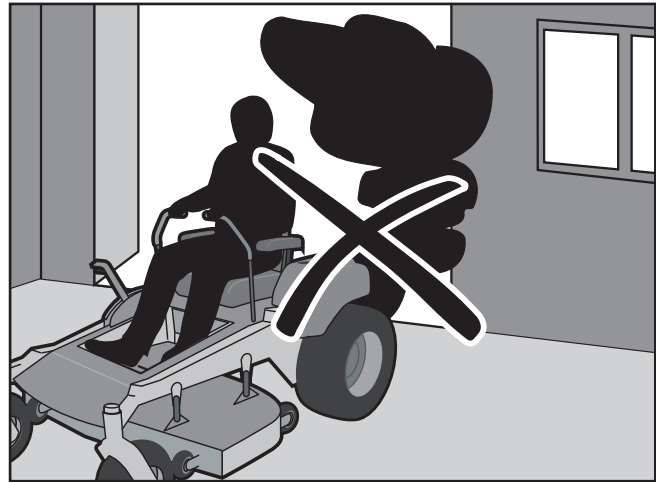

Never drive the machine in an enclosed space

8011-515



WARNING!

Use protective glasses for maintenance work.



WARNING!

The battery contains lead and lead compounds, chemicals that are considered to cause cancer, birth defects, and other reproductive system damage. Wash your hands after handling the battery.

SAFETY

- Do not change the settings of governors and avoid running the engine with overly high engine speeds. If you run the engine too fast, you risk damaging the machine components.
- Sparking can occur when working with the battery and the heavy cables of the starter circuit. This can cause battery explosion, fire or eye injury. Sparking in this circuit can not occur after the chassis cable (normally negative, black) is removed from the battery.
- Use protective goggles.
- Ensure that the fuel filler cap is mounted tightly and no flammable substances are stored in an open vessel.
- Never work with the starter circuit if there is spilled fuel.



WARNING!

Avoid electrical sparking and its consequences by the following routines:

- Disconnect the chassis cable from the battery first and reconnect it last.
- Do not make a bridge short circuit across the starter relay to run the starter.
- Never use the machine indoors or in spaces lacking proper ventilation. The exhaust fumes contain carbon monoxide, an odorless, poisonous, and lethal gas.
- Stop to inspect the equipment if you run over or into anything. If necessary, make repairs before starting.
- Never make adjustments with the engine running.
- The machine is tested and approved only with the equipment originally provided or recommended by the manufacturer. Only use approved repair parts for the machine.
- The blades are sharp and can cause cuts and gashes. Wrap the blades or use protective gloves when handling them.
- Check the parking brake's functionality regularly. Adjust and service as necessary.
- The mulch blades should only be used in familiar areas when higher quality mowing is desired.
- Reduce the risk of fire by removing grass, leaves, and other debris that may have accumulated on the machine. Allow the machine to cool before putting it in storage.

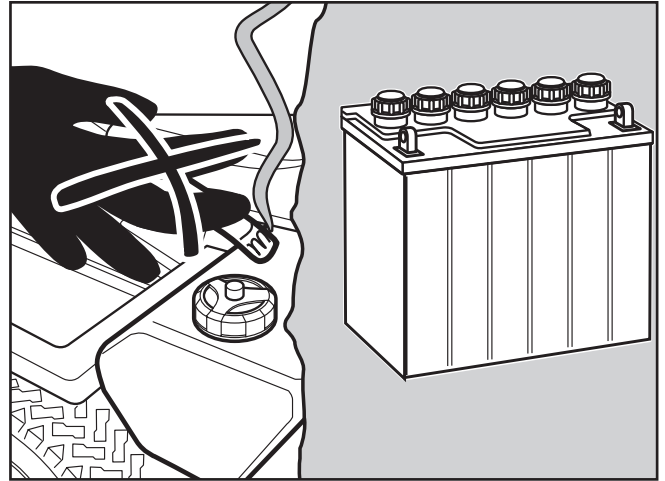

6003-009

Do not smoke when performing maintenance on the battery. The battery can explode and cause serious injury/damage.

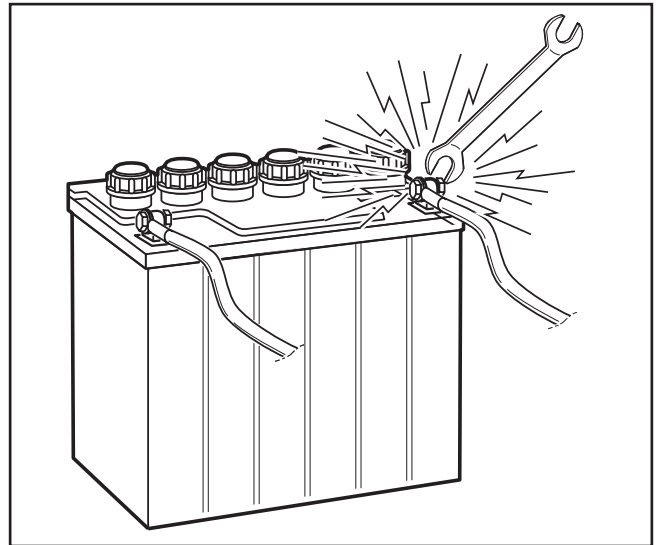

8009-728

Risk of sparking

SAFETY

- The blades are sharp and can cause cuts and gashes. Wrap the blades or use protective gloves when handling them.
- Check the parking brake's functionality regularly. Adjust and service as necessary.
- The mulch blades should only be used in familiar areas when higher quality mowing is desired.
- Reduce the risk of fire by removing grass, leaves, and other debris that may have accumulated on the machine. Allow the machine to cool before putting it in storage.
- Regularly clean deck and underside of deck, avoid spraying engine and electrical components with water.



8011-514

Regularly clean deck

Transport

- The machine is heavy and can cause serious crushing injuries. Be extra cautious when it is loaded on or unloaded from a vehicle or trailer.
- Use an approved trailer to transport the machine. Activate the parking brake, turn off the fuel supply, and fasten the machine with approved fastening devices, such as bands, chains, or straps, when transporting.
- Do not operate this machine on public roadways.
- Check and abide by local traffic regulations before transporting the machine on any road.
- Do not tow this machine, it may cause damage to the drive system.
- Do not tow any trailers, etc. with this mower. They may jackknife or overturn causing damage to the mower and possibly serious injury to the operator.
- Load the unit onto truck or trailer by driving up ramps of suitable strength using a slow speed. Do not lift! The machine is not intended to be lifted by hand.



WARNING!

Escaping hydraulic oil under pressure can have sufficient force to penetrate the skin, causing serious injury. If injured by escaping fluid, see a doctor at once. Serious infection or reaction can develop if proper medical treatment is not administered immediately.

IMPORTANT INFORMATION

The parking brake is not sufficient to lock the machine in place during transport. Ensure that the machine is well fastened to the transport vehicle. Always reverse the machine onto the transport vehicle to avoid tipping it over.

CONTROLS

This operator's manual describes the Dixon Zero Turn Rider. The rider is fitted with a Briggs & Stratton, Kawasaki or Kohler four-stroke overhead valve engine developing 17 - 24 horse power.

Transmission from the engine is made via two belt-driven hydraulic pumps. Using the left and right steering controls, the flow is regulated and thereby the direction and speed.

Control Locations

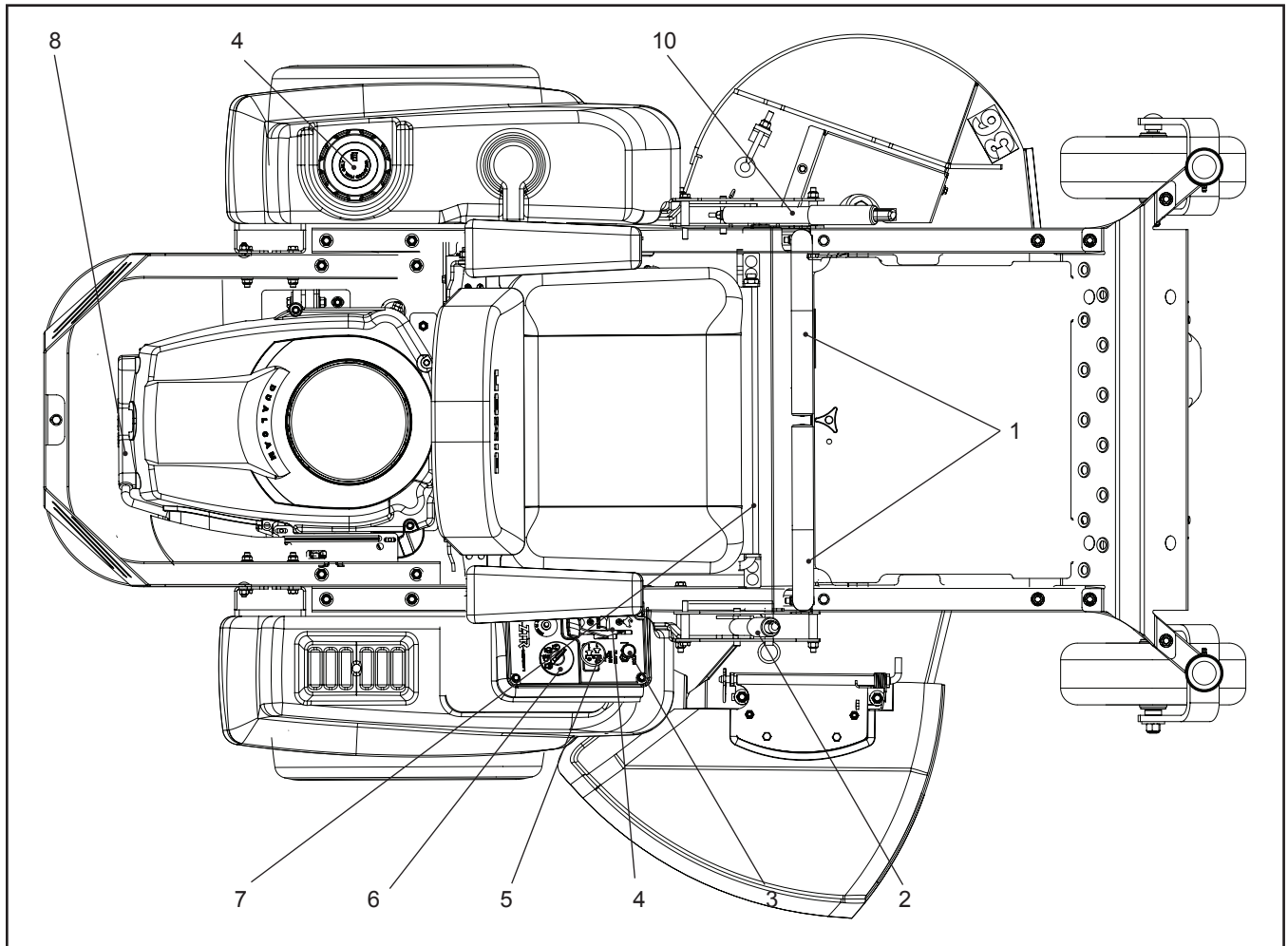

1. Motion Control Levers
2. Lift Lever
3. Choke Control
4. Throttle
5. Blade Switch

6. Ignition Switch
7. Seat Adjustment Lever
8. Bypass Linkage
9. Fuel Tank
10. Parking Brake

CONTROLS

Motion Control Levers

The machine's speed and direction are continuously variable using the two steering controls. The steering controls can be moved forward or backward about a neutral position. Furthermore, there is a neutral position, which is locked if the steering controls are moved outward.

When both controls are in the neutral position (N), the machine stands still.

By moving both controls an equal amount forward or backward, the machine moves in a straight line forward or backward respectively.

In order, for example, to turn right while moving forward, move the right control towards the neutral position. The rotation of the right wheel is reduced and the machine turns to the right.

Zero turn can be achieved by moving one control backward (behind the neutral position) and carefully moving the other steering control forward from its neutral position. The rotation direction when zero turning is determined by which steering control is moved backward behind the neutral position.

If the left steering control is pulled backward, the machine turns to the left. Use extra care when using this maneuver.

If the steering controls are in uneven positions when standing still or do not fit in the slots for moving the controls outward, they can be adjusted

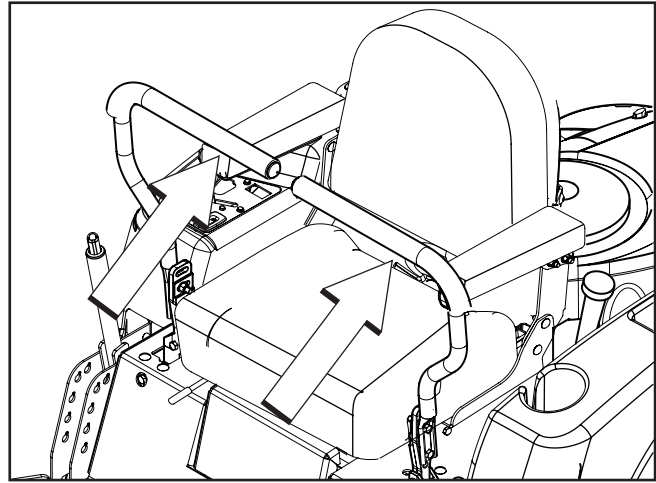

8050-833

Steering controls



WARNING!

The machine can turn very rapidly if one steering control is moved much further forward than the other.

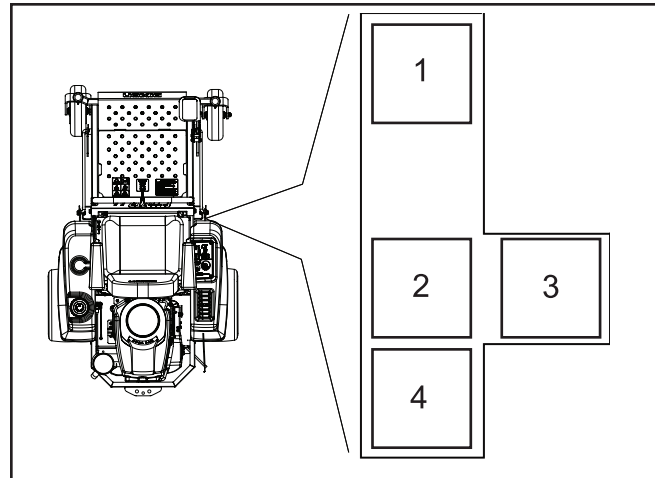

8050-166-1

1. Forward
2. Neutral
3. Neutral slot, Neutral lock
4. Reverse

Motion control lever pattern (right side)

CONTROLS

Seat Adjustment Lever

The seat can be adjusted lengthways. Release levers are located at the lower front right, or on the right side—depending on model. When making adjustments, sit on the seat. Slide the lever and maneuver seat to appropriate placement and release lever.

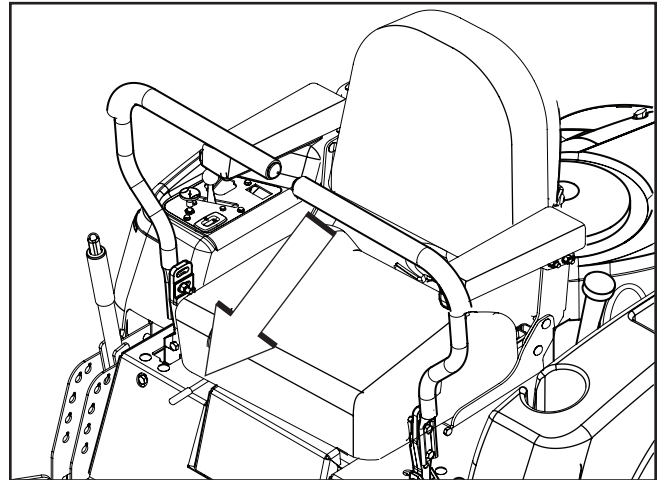

Seat adjustment

8050-165

Bypass Linkage

Unlocking Transmission

When pushing or pulling the mower, engage the EZT (Integrated Zereturn Transaxle) bypass linkages. The EZT bypass linkages are located on the rear of the frame, below the rear engine guard.

1. Raise the deck into the highest cutting position.
2. Pull the EZT bypass linkages up and out of the keyhole slots. Release the levers with the head outside the frame and held in the bypass position.
3. To reengage the EZT's to drive, reverse the above procedure.

Load the machine into truck or trailer by driving up ramps in low gear. **DO NOT LIFT!** The machine is not intended to be lifted by hand.

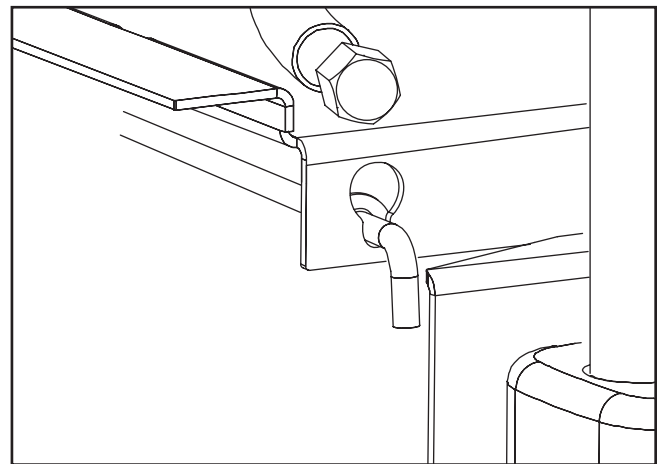

Bypass linkage, EZT engaged

8058-032

IMPORTANT INFORMATION

Before pushing or towing tractor, transmission must be unlocked and park brake released. The tractor should never be pulled at more than 2 miles per hour (3.2 km/h) or for distances over ¼ mile (.402 km). Trailer the unit for distances over ¼ mile.

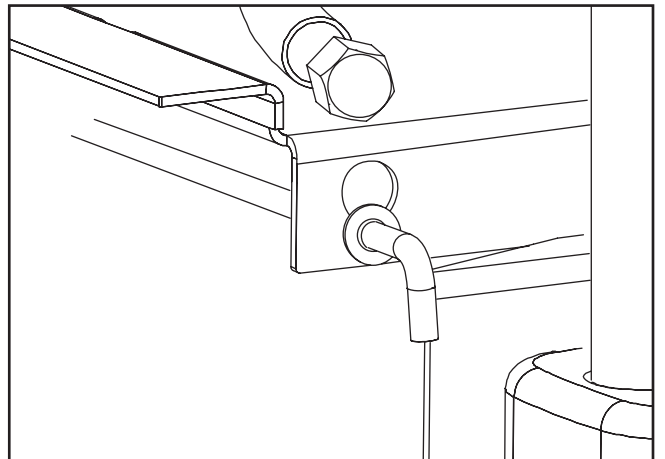

Bypass linkage, EZT locked in the bypass position

8058-032

CONTROLS

Fuel Tank

The machine has one fuel tank, just behind the seat. The tank capacity is 4.5 gallons (17 liters).

The engine will run on a minimum of 85-octane unleaded gasoline (no oil mix). Environmentally adapted alkylate gasoline can be used. See also Technical Data concerning ethanol fuel. Methanol fuel is not allowed.

When operating below 32°F (0°C) use fresh, clean winter grade gasoline to help insure good cold weather starting.

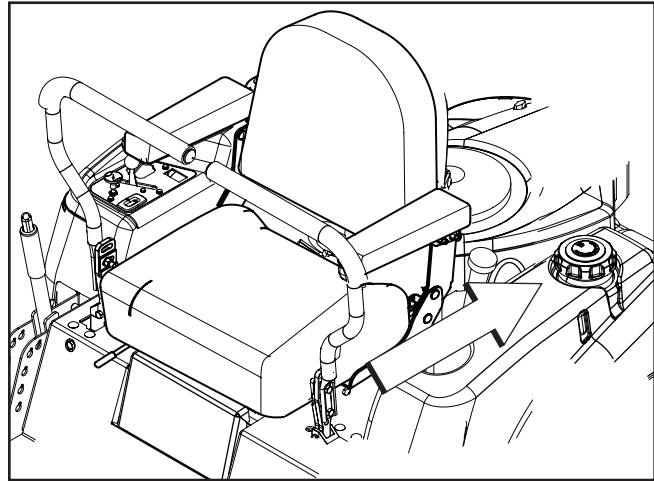

Fuel tank

8058-833



WARNING!

Gasoline is highly flammable. Observe caution and fill the tank outdoors. (See Safety)



WARNING!

Fill to the bottom of the filler neck. Do not overfill. Wipe off any spilled oil or fuel. Do not store, spill or use gasoline near an open flame.



WARNING!

The engine and the exhaust system, become very hot during operation.

Risk for burns if touched.

Allow engine and exhaust system to cool at least two (2) minutes before refueling.

IMPORTANT INFORMATION

Experience indicates that alcohol blended fuels (called gasohol, ethanol or methanol) can attract moisture which leads to separation and formation of acids during storage. Acidic gas can damage the fuel system of an engine while in storage. To avoid engine problems, the fuel system should be emptied before storage of 30 days or longer. Drain the gas tank, start the engine and let it run until the fuel lines and carburetor are empty. Use fresh fuel the next season. See Storage Instructions for additional information. Never use engine or carburetor cleaners in the fuel tank or permanent damage may occur.

CONTROLS

Ignition Switch

The ignition key is placed on the driver's panel and is used to start and stop the engine.

IMPORTANT INFORMATION

Do not run the starter for more than five seconds each time. If the engine does not start, wait about 10 seconds before retrying.

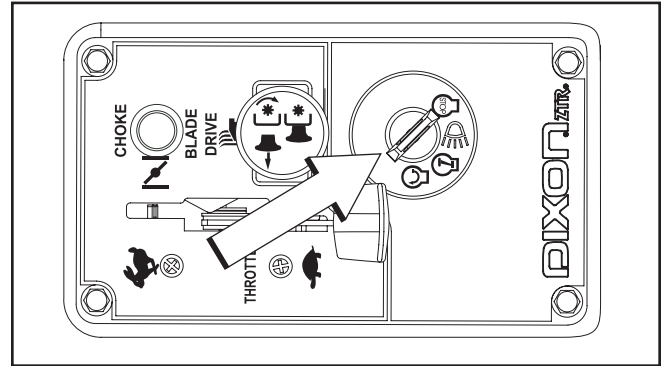

8050-817-1

Ignition Switch

Choke Control

The choke is used for cold starts to provide the engine with a richer fuel mixture. Pull the choke control knob up.

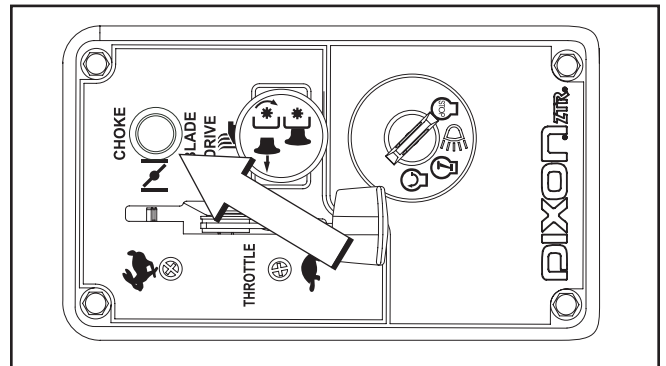

8050-817-1

Choke control

Throttle Control

The throttle control regulates the engine speed and thereby the rate of rotation of the blades, assuming the blade switch is pulled out, see Engaging the Mower Deck.

In order to increase or decrease the engine speed, the control is moved.

Avoid idling the engine for long periods, as there is a risk of fouling the spark plug.

USE FULL THROTTLE WHEN MOWING, for best mower performance and battery charging.

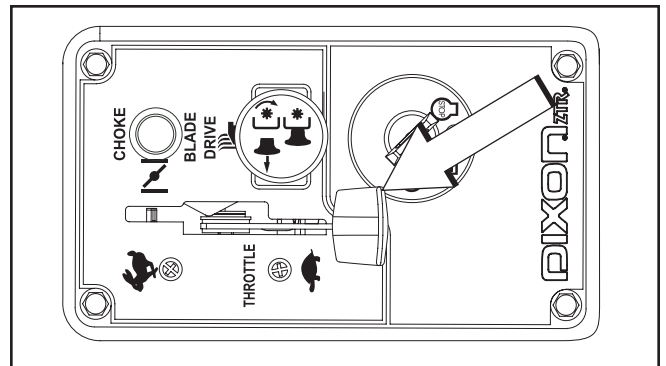

8050-817-1

Throttle control

CONTROLS

Blade Switch

In order to engage the mower deck, pull the knob out; the mower blades are disengaged when the knob is depressed.

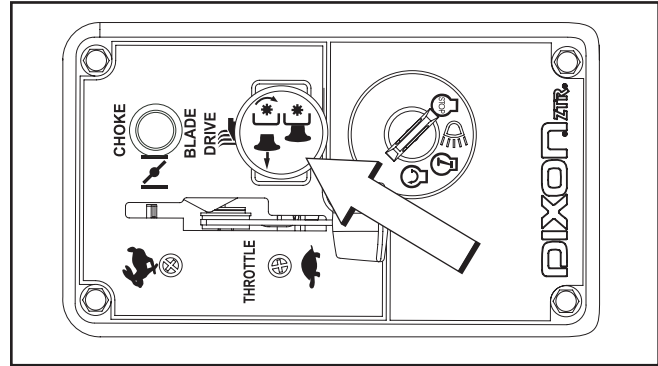

8050-817-1

Blade switch

Parking Brake

The parking brake is found on the left of the machine. Push the release button and pull the lever backward to activate the brake—push forward to release it.

The park brake is designed to hold the mower from moving and is not intended for use in stopping the mower while it is in motion. The engine will stop if the park brake is engaged while the control levers are in the drive position.

IMPORTANT INFORMATION

The machine must stand absolutely still when applying the parking brake. Always set the parking brake before dismounting. Release the parking brake before moving the mower.

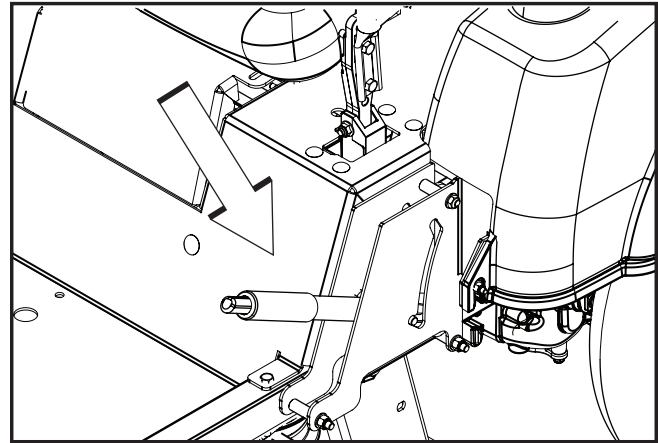

8058-020

Released parking brake

Cutting Height Adjuster

To set the desired deck cutting height, press the release button and move the lever forward to the correct cutting height on the cutting plate. The cutting height range is from 1½" (38mm) to 4" (102mm) in ½" (13mm) increments. The heights are measured from the ground up to the blade tip with the engine not running.

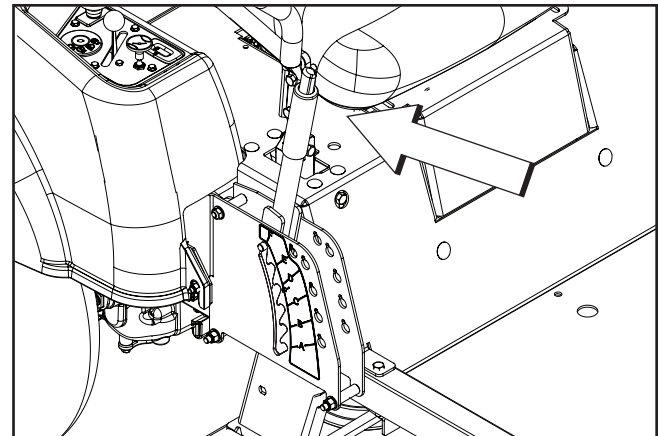

8050-825

Cut height lift lever

IMPORTANT INFORMATION

Always use the high position to transport.

IMPORTANT INFORMATION

In order to obtain an even cutting height it is important that the air pressure in all four tires is the same 15 psi (1 bar).

CONTROLS

Fuses

Fuses are located on the left hand side of the machine. They are accessed by tilting the seat forward. They are flat pin fuses of the same type used in automobiles.

There are two fuses with ratings and functions:

20 Amp Primary fuse

7.5 Amp Mower deck coupling

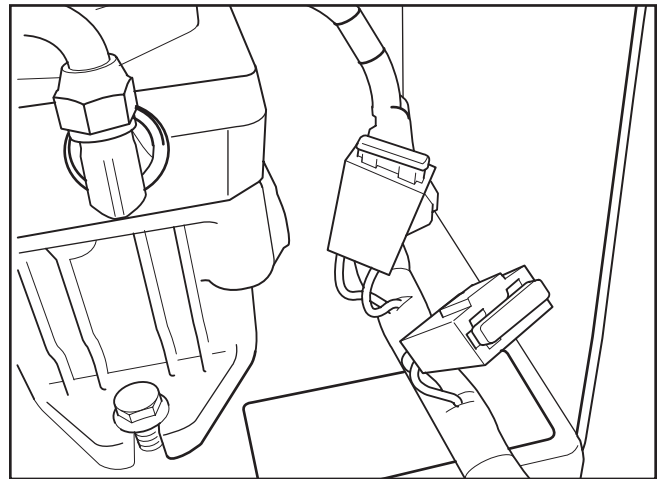

8011-420

Fuses

Fuel Shut Off Valve

The fuel shut off valve is located at the left rear of the seat. The valve is off when the handle tab is turned perpendicular to the fuel line.

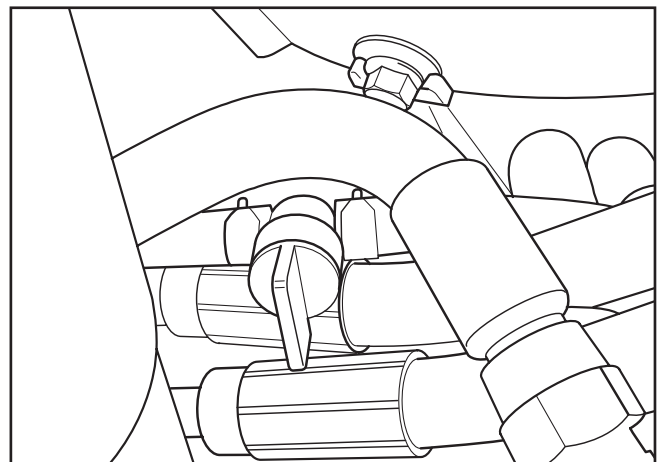

8011-419

Fuel shut off valve in the CLOSED position

OPERATION

Read “Safety Instructions” section and following pages, if you are unfamiliar with the machine.

Training

Zero turn mowers are far more maneuverable than typical riding mowers due to their unique steering capabilities.

We suggest that this section be reviewed in its entirety prior to attempting to move the mower under its own power. Additionally, we suggest when first operating the mower, use a reduced throttle speed and reduced ground speed by NOT moving control levers to the furthest forward or reverse positions during initial operation, or until operator becomes comfortable with controls. We also suggest first time users, or new users to Zero Turn mowers to become familiar with the mower’s movement on a hard surface, such as concrete or blacktop PRIOR to attempting to operate on turf. Until operator becomes comfortable with mower controls and zero turning capability, they may damage turf due to overly aggressive maneuvers.

IMPORTANT INFORMATION

When control levers are in the reverse position they return to neutral when released. This may cause the mower to suddenly stop.

Steering

To move forward and backward

The direction and speed of the mower’s movements is effected by the movement of the control lever(s) on each side of mower. The left control lever controls the left wheel. The right control lever controls the right wheel.

First time users should push mower (see “Moving by Hand” in the “Operation” section) to an open, flat area, without other people or vehicles/obstacles nearby. In order to move unit under its own power, the operator must be in the seat, start engine (see “Before Starting” in “Operation” section), adjust engine speed to idle, disengage parking brake, do not engage blades at this time, rotate control levers inward. As long as

the control levers have not been moved forward or backwards, mower will not move. Slowly move both control levers forward slightly. This will allow mower to start moving forward in a straight line. Pull back on control levers to the neutral position and mower should stop moving. Pull back slightly on control levers, this will allow mower to start moving backwards. Push forward on control levers to the neutral position and mower should stop moving.

To turn to the right

While moving in a forward direction, pull the right lever back towards the neutral position while maintaining the position of the left lever, this will slow the rotation of the right wheel and cause the machine to turn in that direction.

To turn to the left

While moving in a forward direction pull the left lever back towards the neutral position while maintaining the position of the right lever, this will slow the rotation of the left wheel and cause the machine to turn in that direction.

To zero turn

While moving in a forward direction, first pull both control levers back until the mower stops or slows dramatically. Then by alternating one lever slightly to the forward position and the other in the reverse position.

OPERATION

Before Starting

- Read the sections Safety Instructions and Controls before starting the machine.
- Perform the daily maintenance before starting (see Maintenance Schedule in the Maintenance section).
- Check that there is sufficient fuel in the fuel tank.
- Adjust the seat to the desired position.

The following conditions must be fulfilled before the engine can be started:

- The blade switch for engaging the mower blades must be depressed.
- The parking brake must be on.
- Both steering controls must be in the locked (outer) neutral position.

Starting the Engine

- Sit on the seat.
- Raise the mower deck by pushing the release button on the top of the lifting lever. Pull the lifting lever backward to the locked (transport) position.
- Activate the parking brake by pushing the release button in and pulling the lever fully upwards.

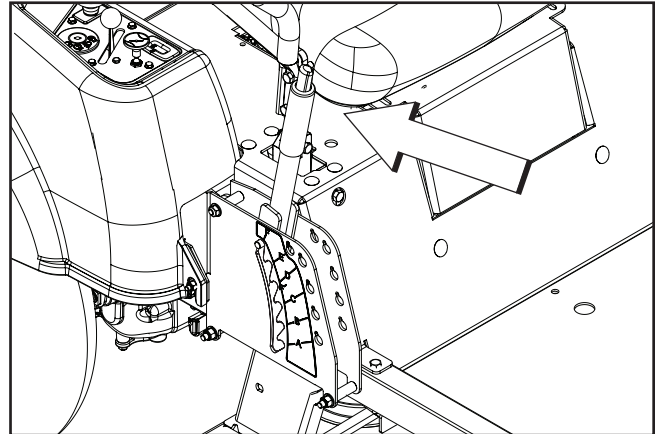

8050-825

Cut height lift lever

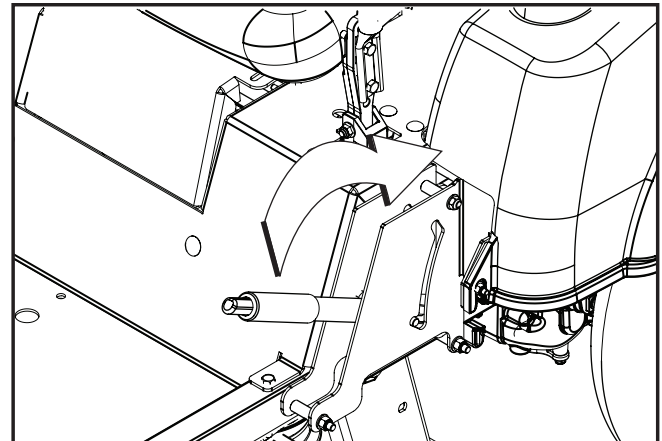

8058-020

Released parking brake

Disengage the mower blades by depressing the blade switch.

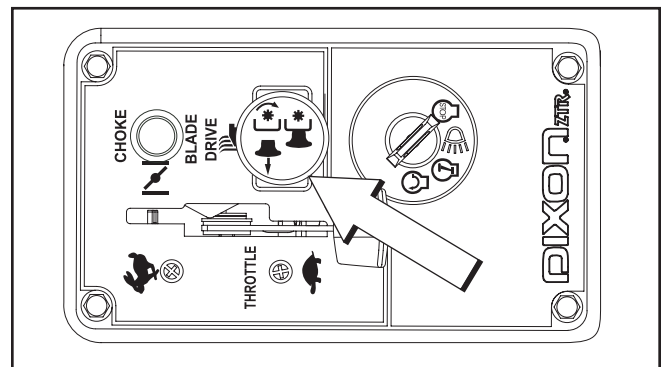

8050-817-1

Blade switch

OPERATION

Move the steering controls outward to the locked (outer) neutral position.

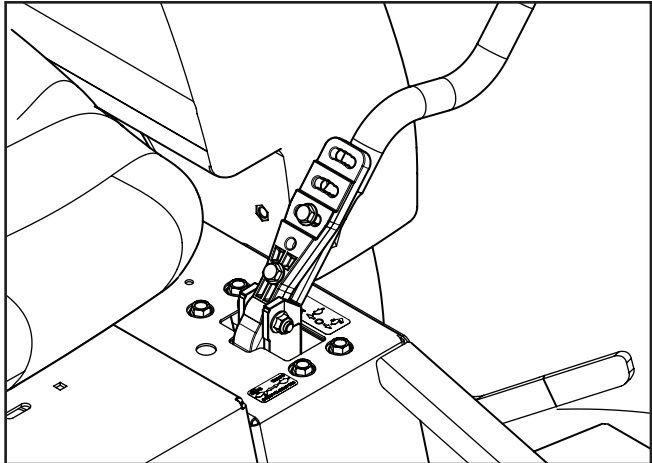

8061-020

Place controls in neutral position

Move the throttle to the middle position.

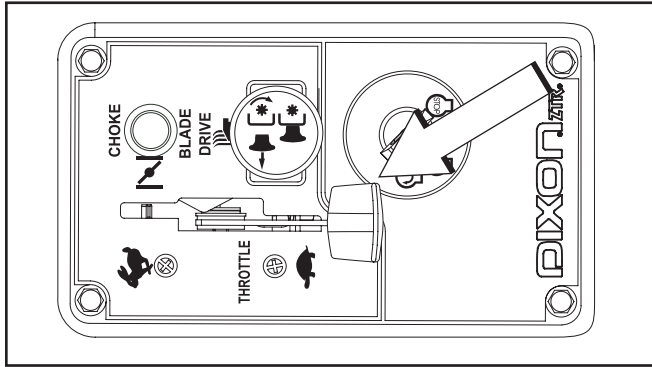

8050-817-1

Set the throttle

If the engine is cold, pull the choke control knob up.

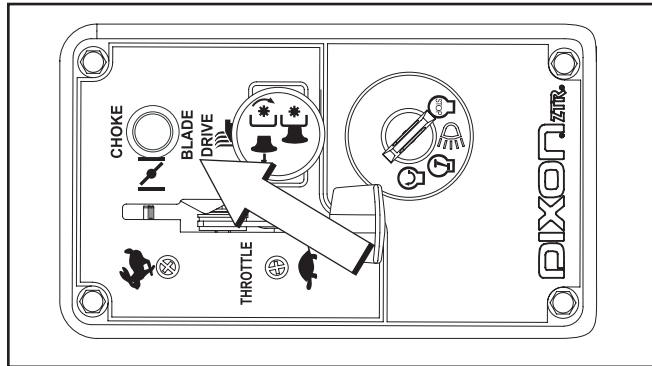

8050-817-1

Set the choke control

OPERATION

Press in and turn the ignition key to the start position.

When the engine starts, immediately release the ignition key back to the run position.

IMPORTANT INFORMATION

Do not run the starter for more than 5 seconds each time. If the engine does not start, wait approximately 10 seconds before retrying.

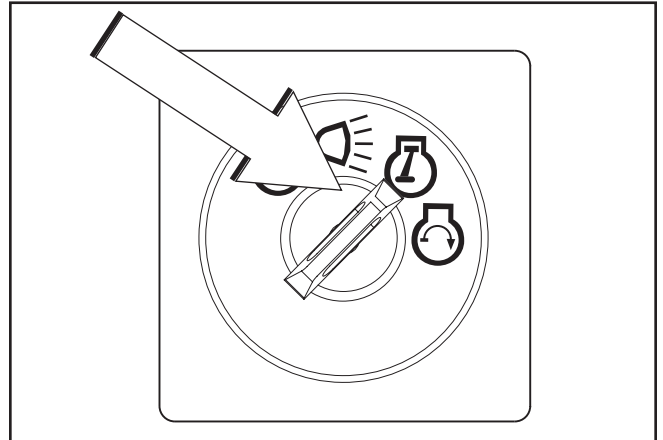

8050-781

Return to run position

Set the desired engine speed with the throttle. Allow the engine to run at a moderate speed, "half throttle", for 3-5 minutes before loading it too heavily. **USE FULL THROTTLE WHEN MOWING** (no choke).

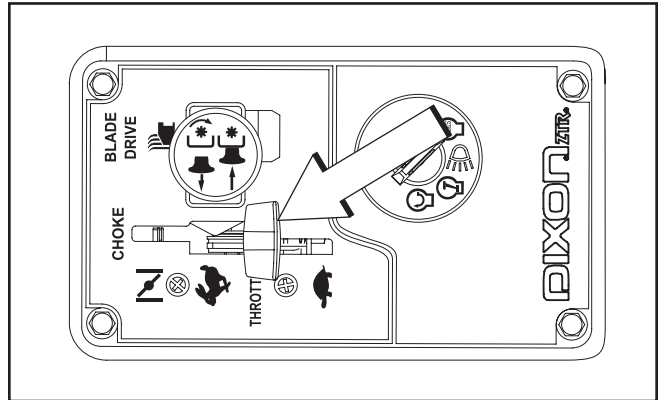

8050-818-1

Set the engine speed



WARNING!

Engine exhaust and certain vehicle components contain or emit chemicals considered to cause cancer, birth defects or other reproductive system damage. The engine exhaust contains carbon monoxide, which is a odorless, colorless, poisonous gas. Do not use the machine in enclosed spaces.

OPERATION

Weak Battery



WARNING!



Lead-acid batteries generate explosive gases. Keep sparks, flame and smoking materials away from batteries. Always wear eye protection when around batteries.

If your battery is too weak to start the engine, it should be recharged. (See "Battery" in the Maintenance Section.)

IMPORTANT INFORMATION

Your mower is equipped with a 12-volt negative grounded system. The other vehicle must also be a 12-volt negative grounded system. Do not use your mower to start other vehicles.

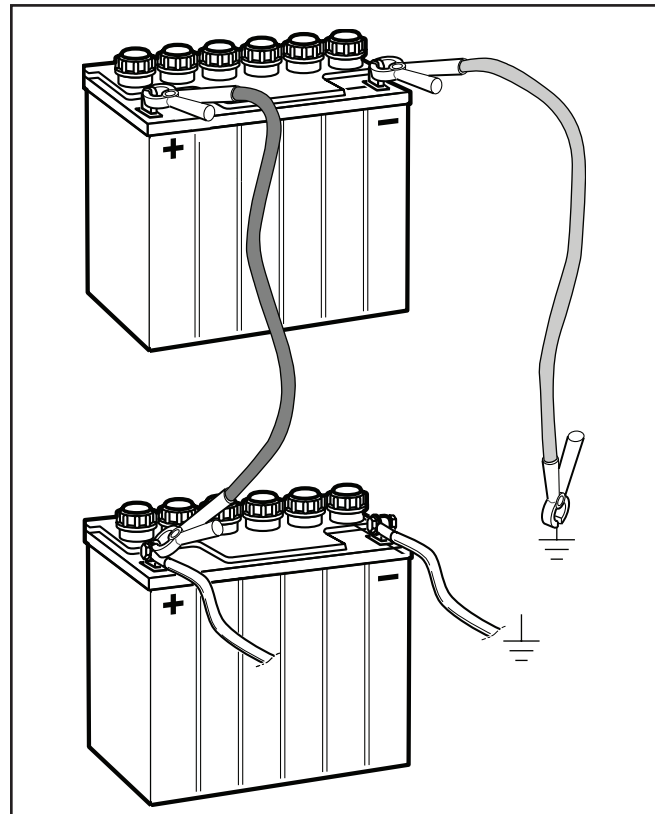

Jumper cable connection

8011-642

If "jumper cables" are used for emergency starting, follow this procedure:

Jumper Cables

1. Connect each end of the RED cable to the POSITIVE (+) terminal on each battery, taking care not to short against chassis.
2. Connect one end of the BLACK cable to the NEGATIVE (-) terminal of the fully charged battery.
3. Connect the other end of the BLACK cable to a good CHASSIS GROUND on the mower with the discharged battery, away from the fuel tank and battery.

To remove cables, reverse order

1. Remove BLACK cable first from chassis and then from the fully charged battery.
2. Remove RED cable last from both batteries.

OPERATION

Running

1. Release the parking brake by moving the lever downward.
Your mower is equipped with an operator presence system. When the engine is running, any attempt by the operator to leave the seat without first setting the parking brake will shut off the engine.
2. Move the steering controls to the neutral position (N).

IMPORTANT INFORMATION

The mower deck's anti-scalp rollers should be evenly adjusted.

3. Set retaining pin into selected cutting height and secure the opposite side with a cotter hairpin.



WARNING!

Ensure that no one is near mower when engaging blade switch. Make sure the work area is free from objects that could be thrown by the rotating blades.

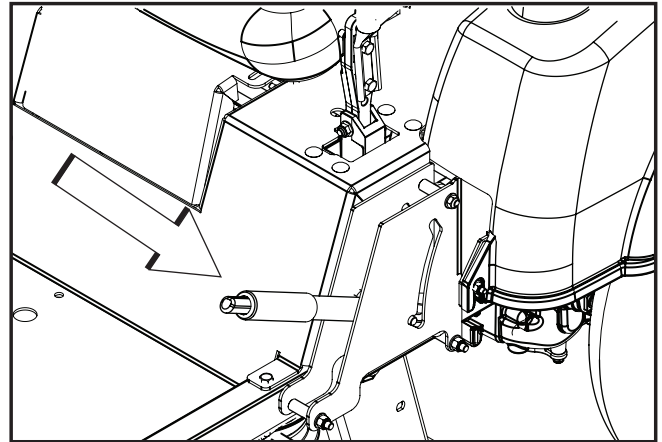

Released parking brake

8058-020

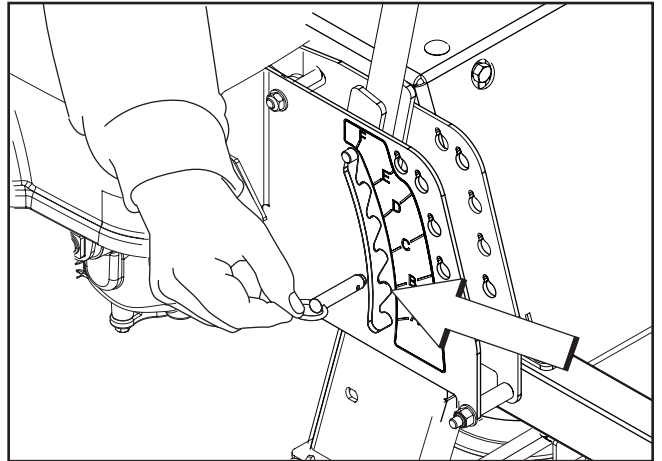

Secure selected cutting height

8058-024

4. Push the release button on the cutting height lever and move lever to the pin, release the button.
5. Set the cutting height with the cutting height adjustment lever.

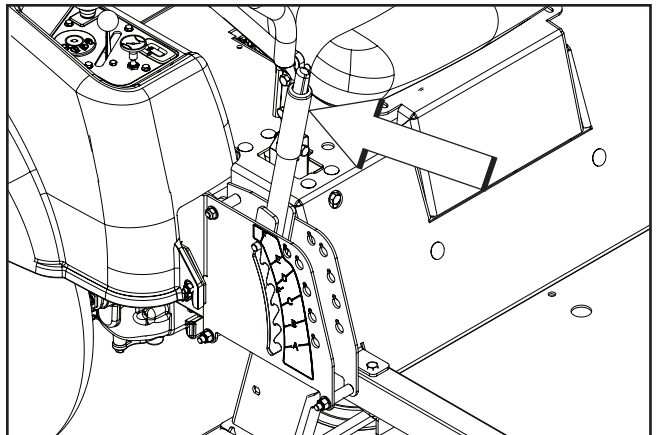

Mower deck lifting lever

8058-019

OPERATION

- Engage the mower deck by pulling out the blade switch.
- Move throttle control to full throttle (not choke). The machine's speed and direction are continuously variable using the two steering controls. When both controls are in the neutral position, the machine stands still. By moving both controls an equal amount forward or backward, the machine moves in a straight line forward or backward respectively. In order, for example, to turn right while moving forward, move the right control towards the neutral position. The rotation of the right wheel is reduced and the machine turns to the right. Turning on the spot can be achieved by moving one control backward (behind the neutral position) and carefully moving the other steering control forward from its neutral position.

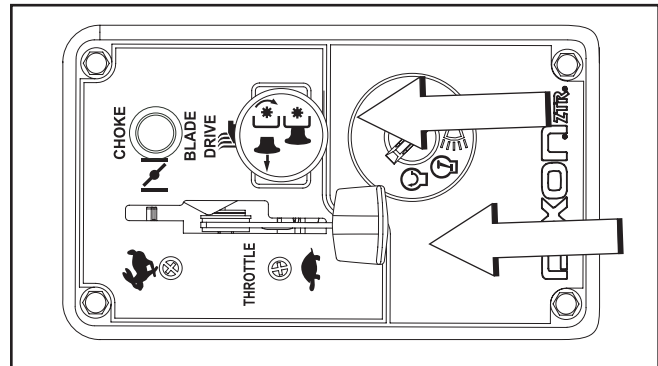

8050-781

Set blade engagement and throttle control

Operating On Hills

Read the Safety Instructions "Driving on Slopes" in the "Safety Instructions".



WARNING!

Do not drive up or down hills with slopes greater than 10 degrees. Do not drive across slopes.

- The slowest speed possible should be used before starting up or down hills.
- Avoid stopping or changing speed on hills.
- If stopping is absolutely necessary, pull drive levers into the neutral position and push to the outside of the unit and engage the parking brake.

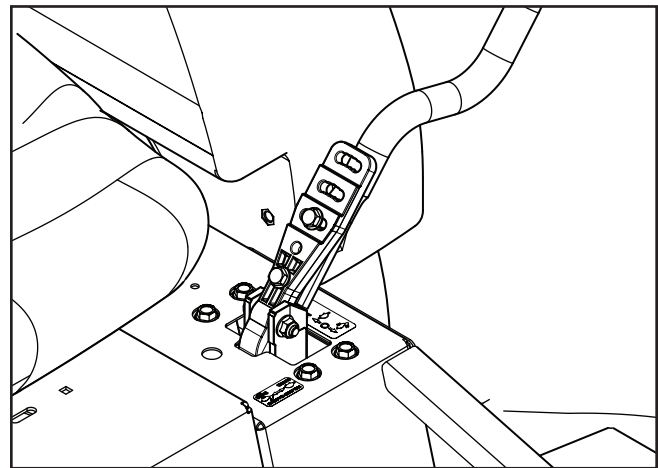

8061-020

Place controls in neutral position

IMPORTANT INFORMATION

Control levers return to neutral when released. This may cause the mower to suddenly stop.

- To restart movement, release the parking brake.
- Pull the control levers back to the center of the mower and press forward to regain forward motion.
- Make all turns slowly.

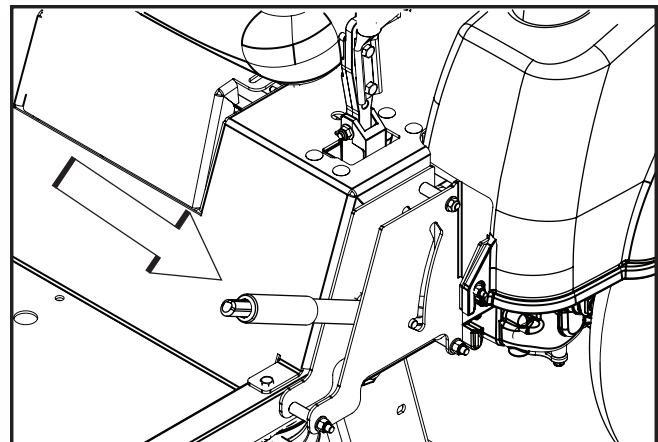

8058-020

Released parking brake

OPERATION

Mowing Tips

- Observe and flag rocks and other fixed objects to avoid collisions.
- Begin with a high cutting height and reduce it until the desired mowing result is attained. The average lawn should be cut to 2½" (64 mm) during the cool season and over 3" (76 mm) during the hot months. For healthier and better looking lawns, mow often after moderate growth. For best cutting performance, grass over 6" (15 cm) in height should be mowed twice. Make the first cut relatively high; the second to the desired height.
- The mowing result will be best with a high engine speed (the blades rotate rapidly) and low speed (the rider moves slowly). If the grass is not too long and dense, the driving speed can be increased without negatively affecting the mowing result.
- The finest lawns are obtained by mowing often. The lawn becomes more even and the grass clippings more evenly distributed over the mown area. The total time taken is not increased as a higher operating speed can be used without poor mowing results.
- Avoid mowing wet lawns. The mowing result is poorer because the wheels sink into the soft lawn, clumps build, and the grass clippings fasten under the cowling.
- Hose the mower deck underside with water after each use. When cleaning, the mower deck shall be raised into the transport position. Make sure the mower is cooled and the engine is off.
- Use compressed air to clean top surface of the deck. Avoid flooding water on top surface, engine and electrical components.
- When the mulching kit is used, it is important that the mowing interval is frequent.



WARNING!

Clear the lawn of stones and other objects that can be thrown out by the blades.

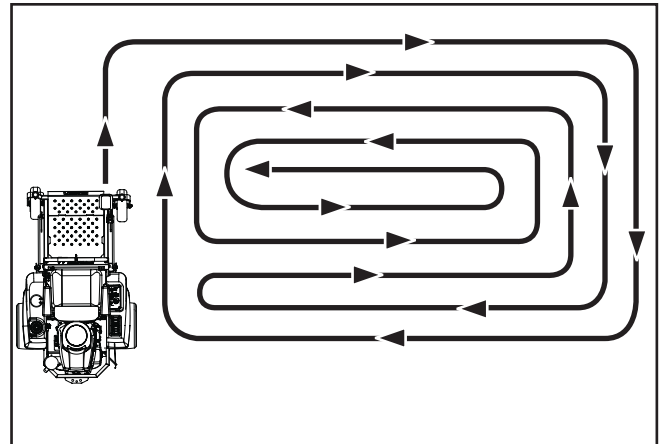

Mowing pattern

8050-819



WARNING!

Never drive the rider on terrain that slopes more than 10 degrees. Mow slopes up and down, never side to side. Avoid sudden directional changes.

OPERATION

Stopping the Engine

Allow the engine to idle a minute in order to attain normal operating temperature before stopping it, if it has been worked hard. Avoid idling the engine for longer periods, as there is a risk of the spark plugs fouling.

- Disengage the mower deck by depressing the blade switch.

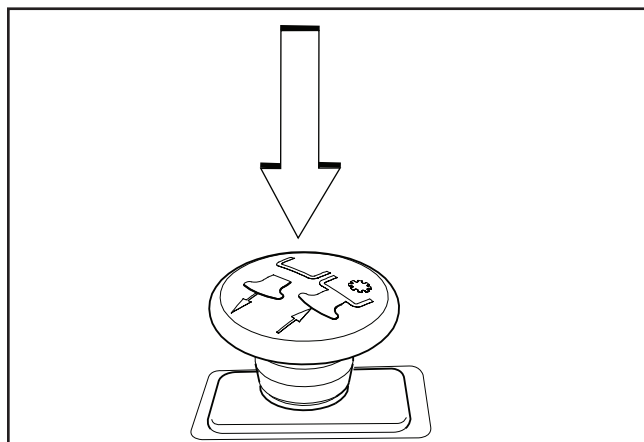

88011-668

Disengage the mower deck

- Raise the mower deck by depressing the button and pulling backward to the transport position.

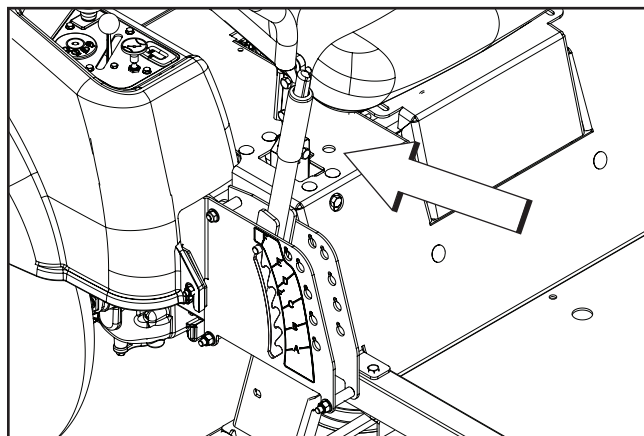

8058-019

Mower deck lifting lever

- When the machine is standing still, activate the parking brake by pulling the lever upward.
- Move the throttle to the minimum position (tortoise symbol). Turn the ignition key to the stop position.

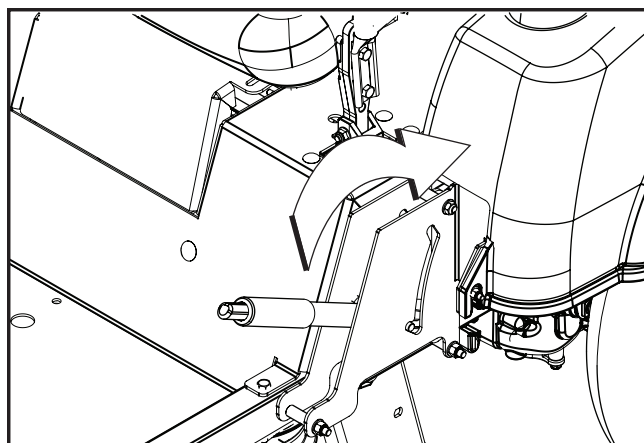

8058-020

Released parking brake

IMPORTANT INFORMATION

Leaving the ignition switch in any other position than "OFF" will cause the battery to be discharged.

OPERATION

- Move the steering controls outward.
- Remove key. Always remove key when leaving the mower to prevent unauthorized use.

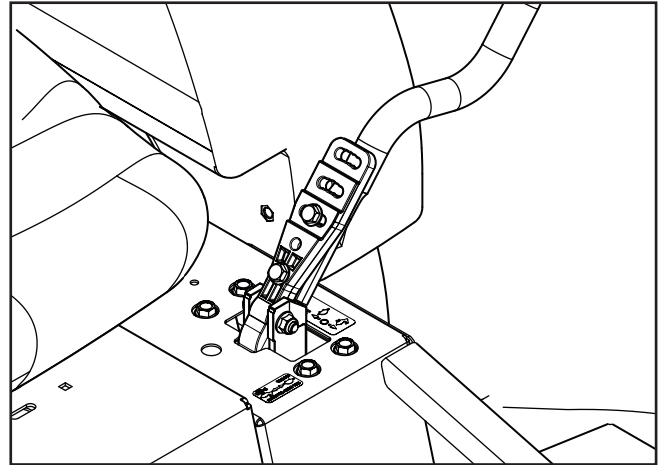

Place controls in neutral position

8061-020

Manual Transport



WARNING!

Make no adjustments without:

- **the engine stopped**
- **the ignition key removed**
- **the parking brake activated**

When pushing or pulling the mower, engage the EZT (Integrated Zereturn Transaxle) bypass linkages. The EZT bypass linkages are located on the rear of the frame, below the rear engine guard.

1. Raise the deck into the highest cutting position.
2. Pull the EZT bypass linkages up and out of the keyhole slots. Release the levers with the head outside the frame and held in the bypass position.
3. To reengage the EZT's to drive, reverse the above procedure.

Load the machine into truck or trailer by driving up ramps in low gear. **DO NOT LIFT!** The machine is not intended to be lifted by hand.

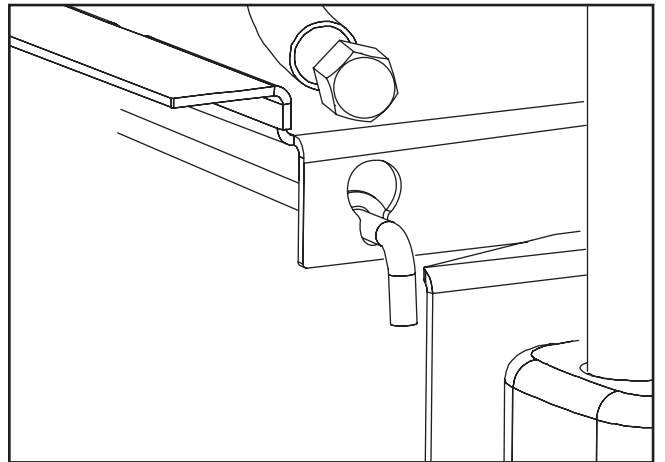

Bypass linkage, EZT engaged

8058-032

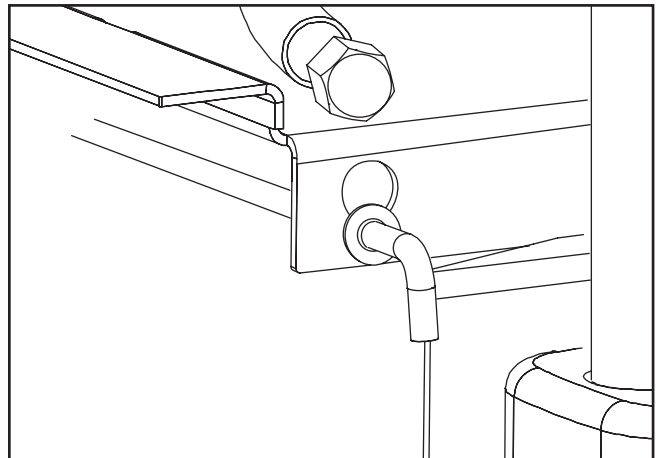

Bypass linkage, EZT locked in the bypass position

8058-032

MAINTENANCE

Maintenance Schedule

The following is a list of maintenance procedures that must be performed on the machine. For those points not described in this manual, visit an authorized service workshop. An annual service carried out by an authorized service workshop is recommended to maintain your machine in the best possible condition and to ensure safe operation.

Read “Maintenance” in the Safety Instructions section.

● = Described in this manual

◆ = Not described in this manual

¹⁾ First change after 5-8 hours. When operating with a heavy load or at high ambient temperatures, replace every 50 hours. ²⁾ In dusty conditions, cleaning and replacement are required more often. ³⁾ Performed by authorized service workshop.

Maintenance	Daily		Weekly	At least once each year	Maintenance interval in hours			
	Before	After			25	50	100	300
Check the parking brake	●							
Check the engine's oil level (every refueling)	●							
Check the safety system	●							
Check for fuel and oil leakages	◆							
Check/clean the engine's cooling air intake		●						
Check the mower deck		●						
Check for loose hardware (screws, nuts)		●						
Clean under the mower deck		●						
Start the engine and blades, listen for unusual sounds		◆						
Check for damage		◆						
Thoroughly clean around the engine		◆						
Clean around belts, belt pulleys		◆						
Check the tire pressures					●			
Check battery					●			
Sharpen/Replace mower blades					●			
Clean the engine's cooling air intake 2)				●	●			
Clean the air cleaner's pre-filter 2) (foam)				●	●			
Clean the air cleaner's filter cartridge 2) (paper filter)				●		●		
Check/adjust the parking brake				◆		◆		
Inspect muffler/spark arrester				◆		◆		

MAINTENANCE

Maintenance	Daily		Weekly	At least once each year	Maintenance interval in hours			
	Before	After			25	50	100	300
Check/adjust throttle cable							●	
Check the condition of belts, belt pulleys				●			●	
Change the engine oil ¹⁾				●		●		
Replace the engine oil filter				●			●	
Clean/replace the spark plugs				●			●	
Replace the fuel filter				●			●	
Replace the air filter (paper filter) ²⁾				●			●	
Check the caster wheels (every 200 hours)							●	
Replace the air cleaner's pre-filter ²⁾ (foam)				●				
Check/adjust the mower deck				●				●
Check the engine valve clearance ³⁾				◆				◆
Perform the 300-hour service ³⁾				◆				◆

¹⁾ First change after 5-8 hours. When operating with a heavy load or at high ambient temperatures, replace every 50 hours. ²⁾ In dusty conditions, cleaning and replacement are required more often. ³⁾ Performed by authorized service workshop.

- = Described in this manual
- ◆ = Not described in this manual



WARNING!

Before performing any service or adjustment checklist

- Engage the parking brake.
- Place the Blade-switch in the disengaged position.
- Turn the ignition switch to “OFF” position and remove the key.
- Make sure the blades and all moving parts have completely stopped.
- Disconnect the spark plug wire from all spark plugs and place the wire where it cannot come in contact with the plug.

MAINTENANCE

Battery

Your mower is equipped with a maintenance free battery and does not need servicing. However, periodic charging of the battery with an automotive type battery charger will extend its life.

- Keep battery and terminals clean.
- Keep battery bolts tight.
- See charge for charging times.



Always use protective glasses when handling the battery.

Cleaning battery and terminals

Corrosion and dirt on the battery and terminals can cause the battery to “leak” power.

1. Lift seat and rotate forward.
2. Disconnect BLACK battery cable first, then the RED battery cable and remove the battery from the machine.
3. Rinse the battery with plain water and dry.
4. Clean terminals and battery cable ends with wire brush until shiny.
5. Coat terminals with grease or petroleum jelly
6. Reinstall battery.

Replacing battery

1. Lift seat and rotate forward.
2. Using two ½” wrenches disconnect BLACK battery cable then RED battery cable.
3. Position deck to lowest setting.
4. Front underside of frame, remove the nuts that secure the battery hold-down.
5. Carefully remove the battery from the mower.
6. Install new battery with terminals in the same position as the old battery.
7. Reinstall battery hold-down and secure with nuts removed in Step 5.
8. First connect RED battery cable to positive (+) battery terminal with hex bolt and hex nut.
9. Connect BLACK grounding cable to negative (-) battery terminal with remaining bolt and nut
10. Tighten securely.
11. Lower seat

STANDARD BATTERY	STATE OF CHARGE	APPROXIMATE BATTERY CHARGING TIME* TO FULL CHARGE AT 80°F / 27°C			
		Maximum Rate at:			
		50 Amps	30 Amps	20 Amps	10 Amps
12.6V	100%	- FULL CHARGE -			
12.4V	75%	20 min.	35 min.	48 min.	90 min.
12.2V	50%	45 min.	75 min.	95 min.	180 min.
12.0V	25%	65 min.	115 min.	145 min.	280 min.
11.8V	0%	85 min.	150 min.	195 min.	370 min.

*Charging time depends on battery capacity, condition, age, temperature and efficiency of charger

IMPORTANT INFORMATION

Do not attempt to open or remove caps or covers. Adding or checking level of electrolyte is not necessary.

Always use two wrenches for the terminal screws.



WARNING!

Do not short battery terminals by allowing a wrench or any other object to contact both terminals at the same time. Before connecting battery, remove metal bracelets, wristwatch bands, rings, etc.

Positive terminal must be connected first to prevent sparks from accidental grounding.

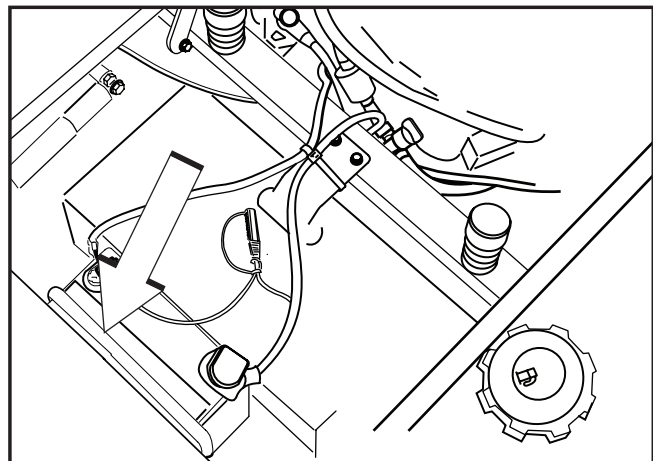

Remove battery hold-down to replace battery

8050-109

MAINTENANCE

Ignition System

The engine is equipped with an electronic ignition system. Only the spark plug requires maintenance. For recommended spark plug, see Technical Data.

1. Remove the ignition cable boot and clean around the spark plug.
2. Remove the spark plug with a spark plug socket wrench.
3. Check the spark plug. Replace the spark plug if fouled, the electrodes are burned and if the insulation is cracked or damaged. Clean the spark plug with a steel brush if it is to be reused.
4. Measure the electrode gap with a gapping tool. The gap should be .030" (0.75 mm). Adjust as necessary by bending the side electrode.
5. Reinsert the spark plug, turning by hand to avoid damaging the threads.
6. After the spark plug is seated, tighten it using a spark plug wrench so that the washer is compressed. A used spark plug should be turned 1/8 of a turn from the seated position. A new spark plug should be turned 1/4 turn from the seated position.
7. Replace the ignition cable.

IMPORTANT INFORMATION

Fitting the wrong spark plug type can damage the engine.

Inadequately tightened spark plug can cause overheating and damage the engine. Tightening the spark plug too hard can damage the threads in the cylinder head.

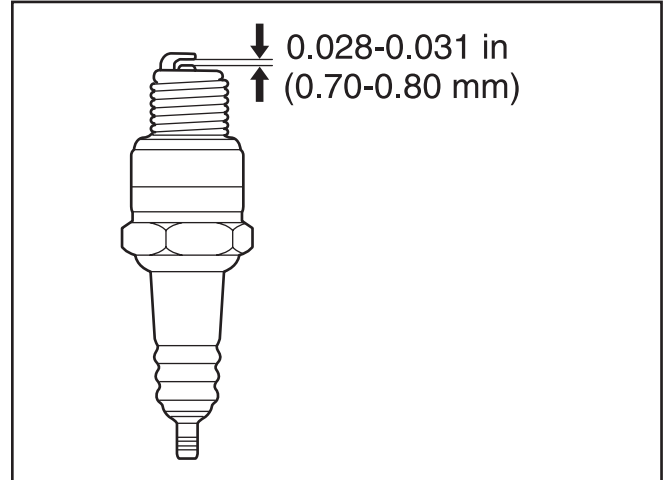

Measure the electrode gap

8011-054

Safety System

The machine is equipped with a safety system that prevents starting or driving under the following conditions.

The engine can only be started when:

The mower deck is disengaged.

- The steering controls are in the outer, locked neutral position.
- The driver is sitting in the driver's seat.
- The parking brake is on.

Make daily inspections to ensure that the safety system works by attempting to start the engine when one of the conditions is not met. Change the conditions and try again.

If the machine starts when one of these conditions is not met, turn the machine off and repair the safety system before using the machine again.

Make sure the engine stops when the parking brake is not engaged and the operator leaves the seated position.

Check that the engine stops if the mower blades are engaged and the driver temporarily moves off the drivers seat.

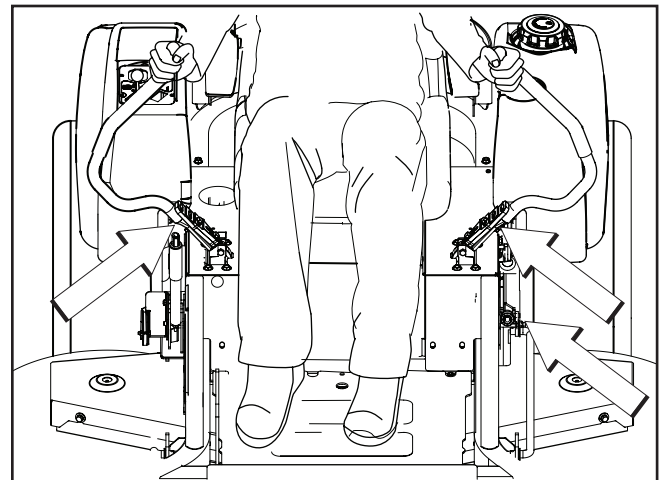

Steering controls locked in neutral

8058-026-1

MAINTENANCE

Engine Cooling Air Intake

Check that the engine's cooling air intake is free from leaves, grass, and dirt.

If the cooling air intake is clogged, engine cooling deteriorates, which can lead to engine damage.

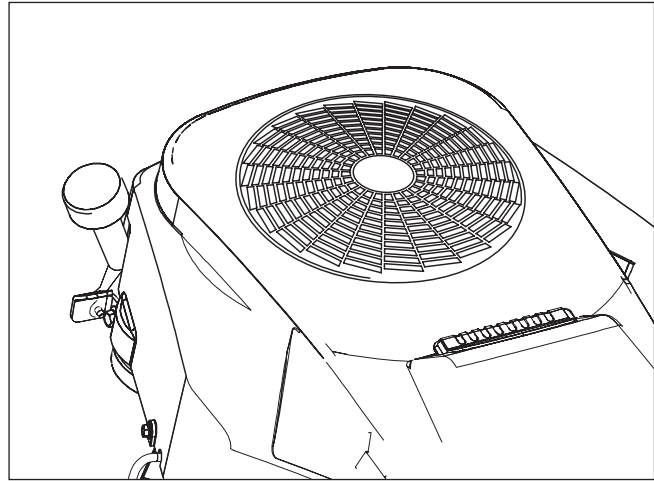

8061-014

Check and clean the cooling air intake

Throttle Cable

Check that the engine responds to throttle increases and that a good engine speed is attained at full throttle.

If doubts arise, contact the service workshop.

If adjustments are necessary, they can be made as follows for the lower cable:

1. Loosen the clamping screw for the cable's outer casing and move the throttle to the full throttle position.
2. Check that the throttle cable is mounted in the correct hole in the lower lever, see illustration.
3. Push the throttle cable's outer casing as far to the left as possible and tighten the clamping screw.

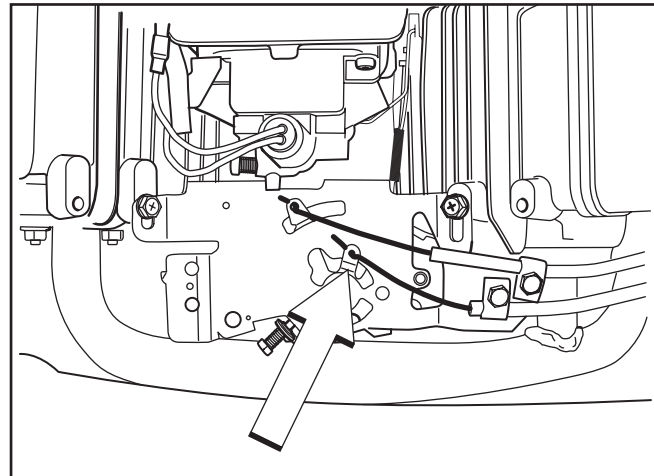

8011-605

Adjusting the throttle cable

Choke Cable

If the engine produces black smoke or is difficult to start, this may be because the choke cable is incorrectly adjusted (upper cable).

If doubts arise, contact the service workshop.

If adjustments are necessary, they can be made as follows:

1. Loosen the clamping screw for the cable's outer casing and move the choke lever to the full choke position.
2. Check that the choke cable is mounted in the upper lever, see illustration. Push the choke cable's outer casing as far to the right as possible and tighten the clamping screw.

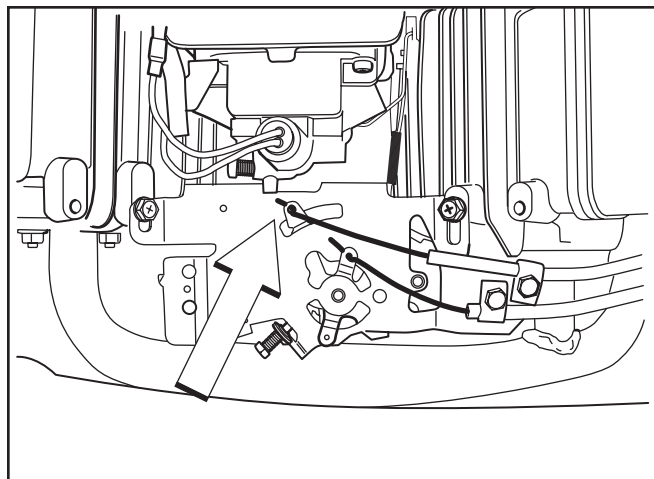

8011-605

Adjusting the choke cable

MAINTENANCE

Air Filter

If the engine seems weak or runs unevenly, the air filter may be clogged. If run with a dirty air filter, the spark plugs can become fouled, disrupting operation. For this reason, it is important to replace the air filter regularly (see the heading Maintenance Schedule for the proper service interval).



WARNING!

The engine and the exhaust system become very hot during operation. There is a risk for burns if touched. Allow engine and exhaust system to cool at least two (2) minutes.

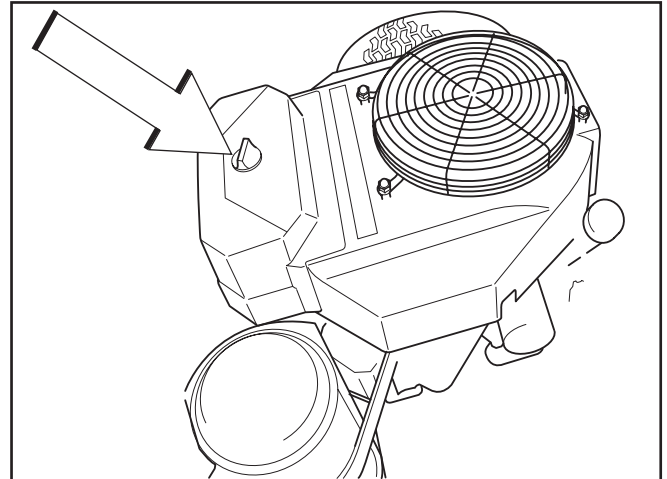

8011-768

Remove the air filter cowling

Kawasaki Engine

1. Remove the plastic fastener on the top of the air filter cowling and remove the air filter cowling.
2. Remove the foam rubber pre-filter and clean using a mild detergent. Squeeze dry with a clean cloth.

IMPORTANT INFORMATION!

Do not use compressed air to clean the air filter. Do not wash the paper filter. Do not oil the paper filter.

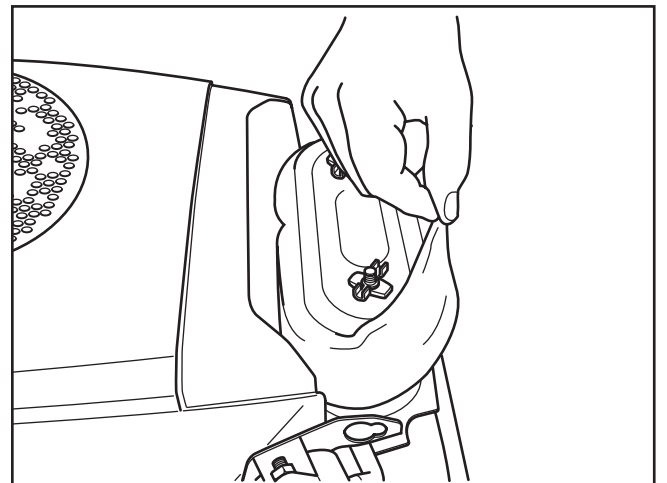

8011-557

Remove pre-filter

3. Remove the wing nuts for the air filter and remove the paper filter. Tap the paper filter against a fixed surface to remove dust. If the paper filter is still dirty, it must be replaced.

To refit the filter:

1. Check that the seal on the bottom of the paper filter is whole.
2. Mount the paper filter in the air filter housing and tighten the wing nuts.
3. Refit the pre-filter on the paper filter.
4. Replace the cowling over the air filter housing. Do not over tighten the plastic fastener.

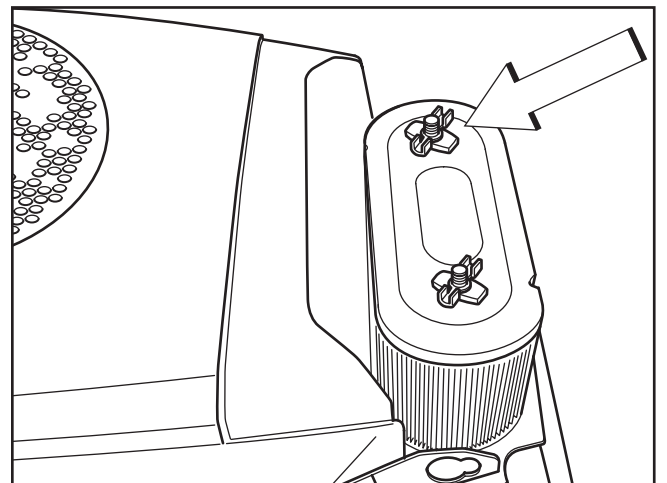

8011-558

Remove paper filter

MAINTENANCE

Kohler Engine

These engines are equipped with a replaceable, high density paper air cleaner element. Some engines are also equipped with an oiled, foam precleaner surrounding the paper element.

Check the air cleaner daily or before starting the engine. Check for a buildup of dirt and debris around the air cleaner system. Keep this area clean. Also check for loose or damaged components. Replace all bent or damaged air cleaner components.

Servicing Precleaner

If so equipped, wash and re-oil the precleaner every 25 hours of operation (more often under extremely dusty or dirty conditions). Replace the precleaner annually, or every 100 hours.

1. Open the door on the blower housing to access the air cleaner element and precleaner.
2. Unhook the latch and remove the air cleaner element assembly for servicing. Make sure the base and the sealing areas are clean before reassembly.
3. Wash the precleaner in warm water with detergent. Rinse the precleaner thoroughly until all traces of detergent are eliminated. Squeeze out excess water (do not wring). Allow the precleaner to air dry.
4. Saturate the precleaner with new engine oil. Squeeze out all excess oil.

Servicing Paper Element

Check the paper element every 50 hours of operation, (more often under extremely dusty or dirty conditions). Clean or replace the element as necessary. Replace the air cleaner element annually, or every 100 hours.

1. Remove the precleaner (if so equipped) from the paper element.
2. Gently tap the paper element to dislodge dirt. Do not wash the paper element or use pressurized air, as this will damage the element. Replace a dirty, bent, or damaged element with a new one. Handle the new element carefully; do not use if the sealing surfaces are bent or damaged.
3. Clean the air cleaner base as required and check condition.
4. Reinstall the precleaner (if equipped) over the paper air cleaner element and install on the base. Secure with the latch.
5. Close and latch the door.

IMPORTANT INFORMATION

Operating the engine with loose or damaged air cleaner components could allow unfiltered air into the engine causing premature wear and failure.

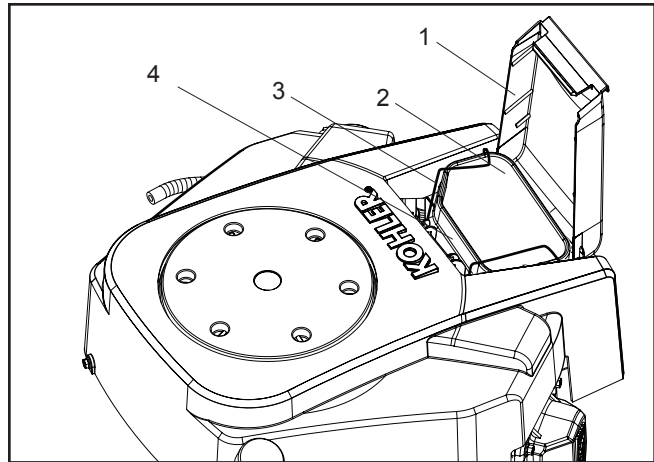

8058-028

1. Air cleaner access door
 2. Air cleaner element
 3. Latch
 4. Precleaner (on some models)
- Air filter cleaning and replacement*

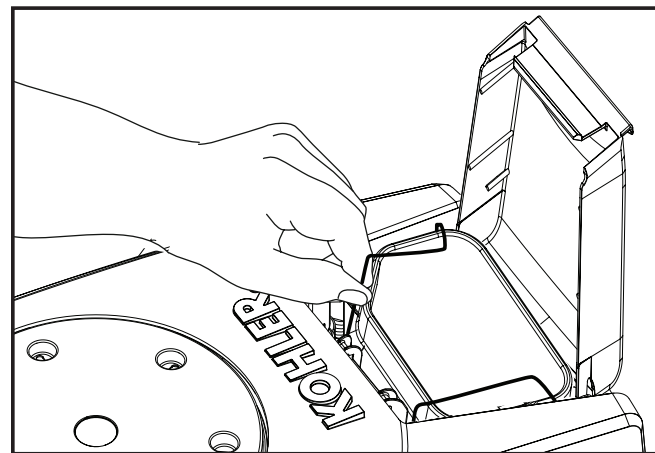

8058-029

Unlatch and remove element

MAINTENANCE

Briggs & Stratton Engine - 19 HP

1. Pull up the handle on the air filter cover. Unhook and turn towards the engine to remove.
2. Clean the area around the filter element to prevent debris from getting into the engine when the element is removed.

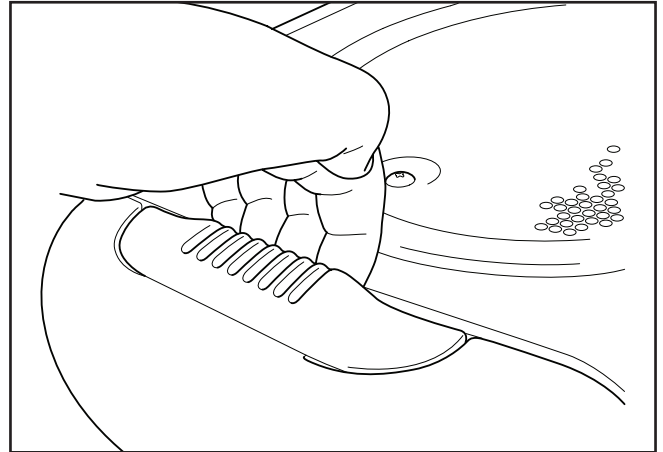

8009-406

Pull up on handle



WARNING!

The engine and the exhaust system become very hot during operation. Risk for burns if touched.

Allow engine and exhaust system to cool at least two (2) minutes.

3. Lift out the filter element. Replace a dirty, bent or damaged element with a new one. Handle the new element carefully and do not use if the sealing surfaces are bent or damaged. If the element can be reused, tap it against a solid surface to remove dust.

IMPORTANT INFORMATION

Do not use compressed air to clean the air filter. Filter should be assembled dry and not be oiled.

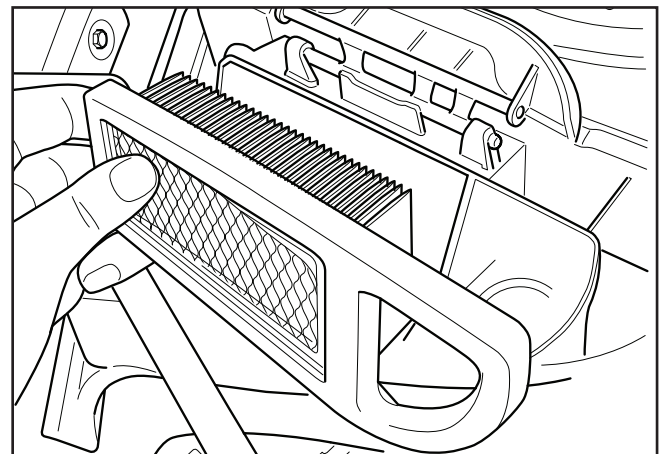

8009-409

Remove air filter element

MAINTENANCE

- Carefully lift out the precleaner from the fan housing. Clean the fan housing so debris does not fall into the carburetor.
- Install a new precleaner and the new or cleaned air filter element into the fan housing.

IMPORTANT INFORMATION

Operating the engine with loose or damaged air cleaner components could allow unfiltered air into the engine causing premature wear and failure.

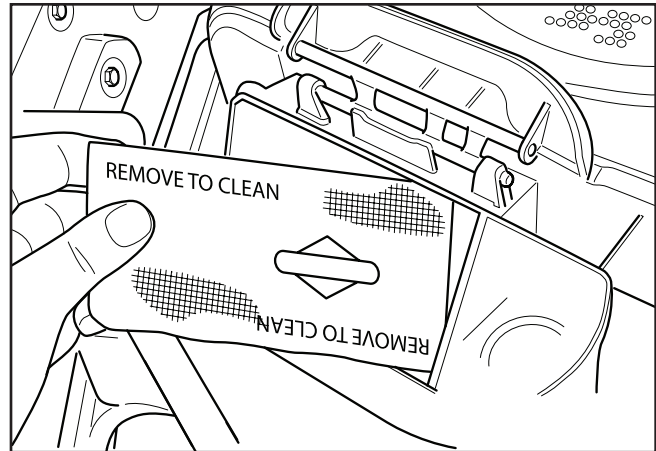

8009-408

Remove precleaner

- Align the tabs on the cover with the slots in the housing and replace air filter cover.

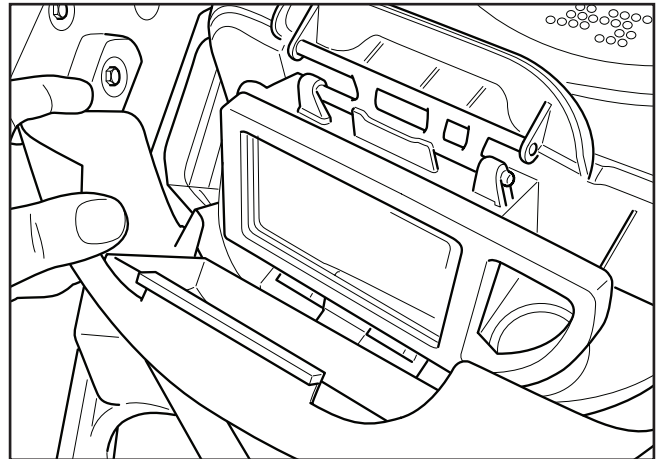

8009-407

Align the tabs

- Pull the handle outwards. Secure the handle in the air filter cover and press inwards to close.

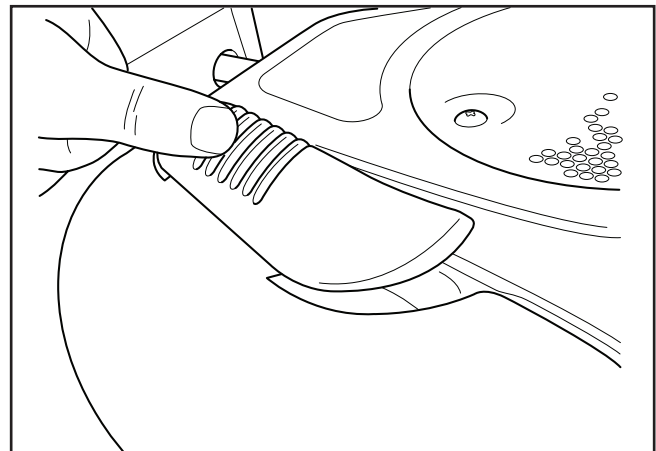

8009-410

Close the cover

MAINTENANCE

Briggs & Stratton Engine - 22 HP

1. Loosen screws and remove air filter cover.
2. Remove the filter cartridge by pulling upwards along the outside edge.



WARNING!

The engine and the exhaust system become very hot during operation. Risk for burns if touched.

Allow engine and exhaust system to cool at least two (2) minutes.

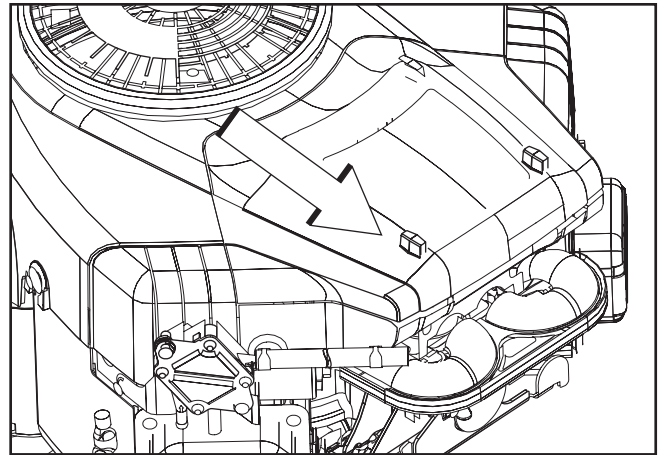

Loosen cover screws

8009-406

3. Remove the foam filter (precleaner). Clean the foam filter with mild detergent and water. Squeeze dry in a clean cloth. Do not oil the foam sleeve.
4. Tap the paper filter against a fixed surface to remove dust. If the paper filter is still dirty, it must be replaced.
5. Wipe clean the inside of air filter housing.
6. Refit the foam filter (pre filter).

IMPORTANT INFORMATION

Do not use compressed air to clean the air filter.

Do not wash the paper filter.

Do not oil the paper filter.

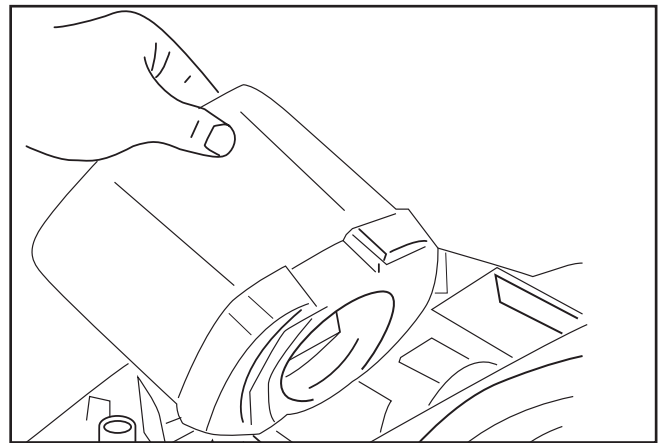

Remove filter

8019-014

7. Mount the filter in the air filter housing.
8. Replace the cover over the air filter housing and secure with screws.

IMPORTANT INFORMATION

Operating the engine with loose or damaged air cleaner components could allow unfiltered air into the engine causing premature wear and failure.

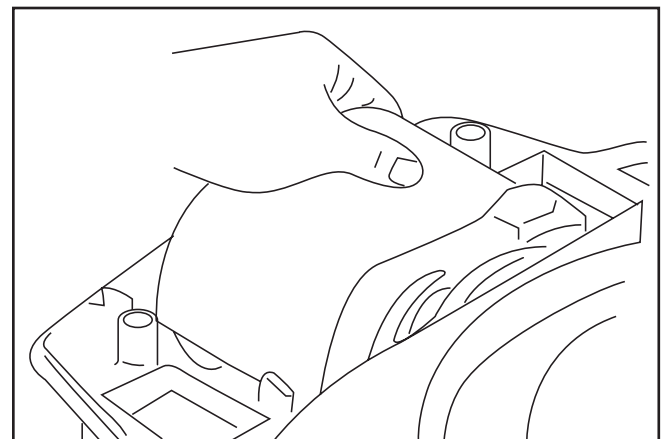

Reinstall filter

8019-015

MAINTENANCE

Fuel Filter

Replace the line-mounted fuel filter every 100 hours (once per season) or more regularly if it is clogged.

Replace the filter as follows:

1. Move the hose clamps away from the filter. Use flat-nosed pliers.
2. Pull the filter loose from the hose ends.
3. Push the new filter into the hose ends. Position the filter with the "FLOW" arrow pointing up toward the carburetor. If necessary, a soap solution can be applied to the filter ends to ease mounting.
4. Move the hose clamps back toward the filter.

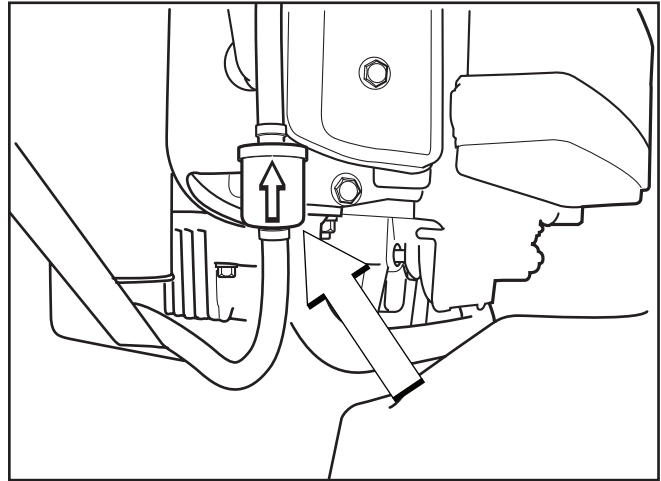

8009-146

Fuel filter

Fuel Pump Air Filter

Regularly check that the fuel pump's air filter is free from dirt.

Remove the screws and open the pump, no hoses need be removed.

The filter can be cleaned with a brush if necessary.

Replace the filter on the console.

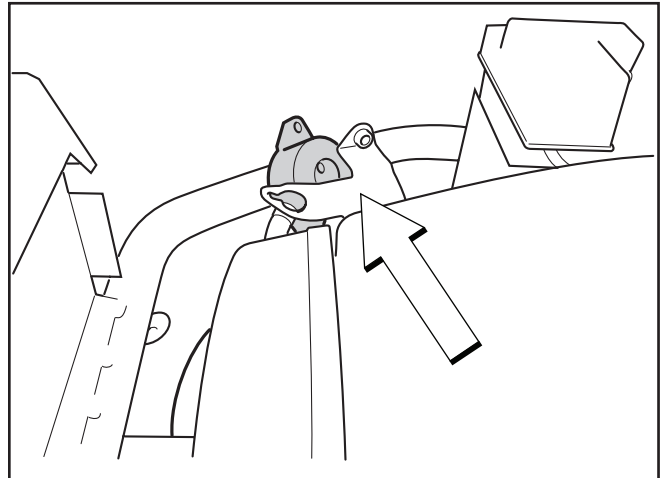

8009-147

Fuel pump air filter

Tire Pressures

All four tires should have a pressure of 15 psi / 103 kPa / 1 bar.

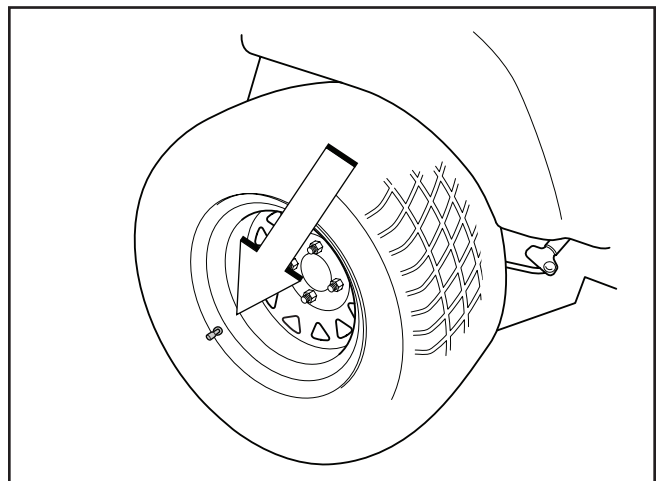

8011-564

Check tire pressure

MAINTENANCE

Parking Brake



WARNING!

The machine must be standing absolutely still when the park brake is engaged.

Visually check that no damage is found on the lever, linkages, or switch belonging to the parking brake. Perform a stand still test and check that there is a braking action.

To adjust the parking brake, contact the Dixon service workshop.



WARNING!

Faulty adjustment can cause an accident.

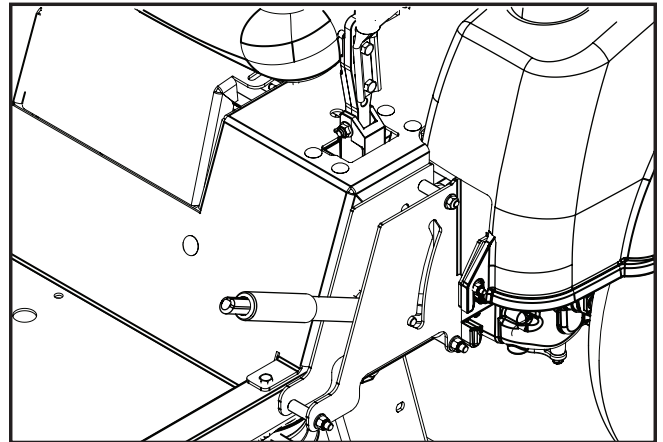

8058-020

Released parking brake

V-belts

Check every 100 hours of operation. Check for severe cracking and large nicks.

NOTE: The belt will show some small cracks in normal operation.

The belts are not adjustable. Replace belts if they begin to slip from wear.

Deck Belt

1. Park on a level surface. Apply parking brake.
2. Lower the deck into the lowest cutting position.
3. Remove bolts from belt shields and remove shields.
4. Remove any dirt or grass that may have accumulated around the cutter housings and entire deck surface.
5. Carefully roll the belt over the top of the cutter housing pulleys and remove belt.

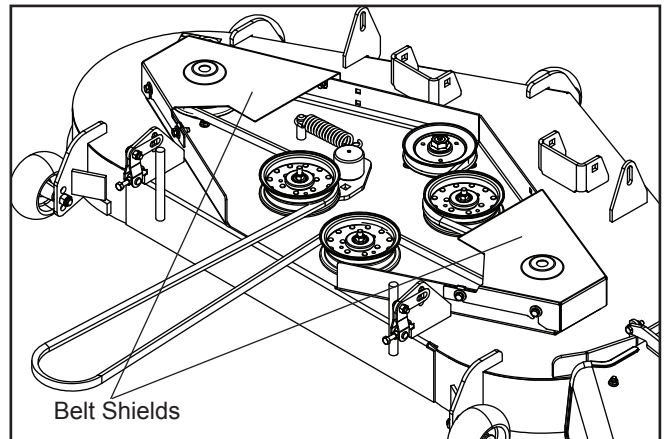

Removing deck belt

MAINTENANCE

Deck belt installation

NOTE: For ease in installing the deck belt, refer to the routing decal on the top of the deck.

1. Wrap the deck belt around the electric clutch pulley that is located on the engine shaft.
2. Route the belt forward and up onto the deck.
3. Place belt around spring loaded idler pulley.
4. Wrap the belt around the stationary idler pulley and around the mandrel housings.
5. Push inward on the idler arm and carefully route belt over stationary idler pulley. Once belt is properly routed, slowly release idler arm to tension belt.
6. Double check belt routing to make sure it **matches the decal affixed to the deck**, and the belt does not have any twist. Correct as needed.
7. Replace belt shields on both mandrel housings and secure with fasteners.

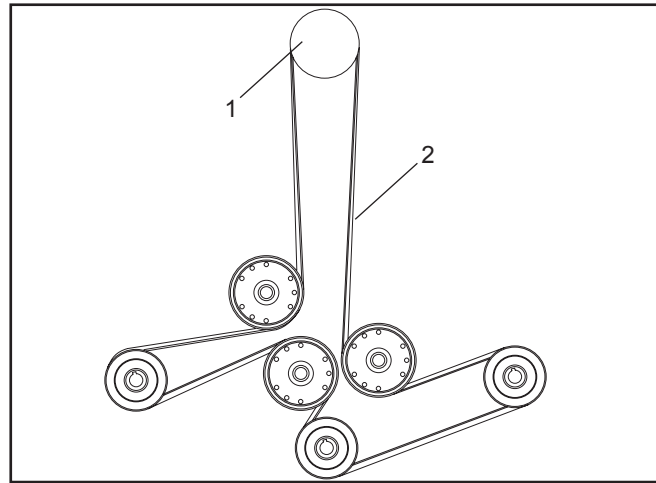

8011-764

1. Clutch pulley
 2. Deck belt
- Belt routing, 54" deck belt*

Pump Belt

Replacing EZT (E-Series Zeroturn Transaxle) belt

Park the mower on a level surface. Engage the parking brake.

EZT belt removal

NOTE: Be careful not to damage the fan blades on the EZT's as this can affect cooling or damage the EZT's

- Remove the deck belt (see Deck Belt Removal in this section of the manual).
- Create slack in the belt by removing the spring on the pump idler arm.
- The belt should now be able to be removed from the engine pulley and EZT pulleys.

Belt installation

- Wrap the EZT belt around the EZT pulleys
- Route the belt around the inside of the idler pulley.
- Wrap the belt around the engine pulley.
- Reattach the spring on the pump idler arm.
- Install clutch on to engine shaft (pulley side down) make sure key is installed and align the clutch anti rotation tab into slot on clutch. Secure clutch, install wire.
- Reinstall the deck belt onto the electric clutch belt (see Deck Belt Removal in this section of the manual).

MAINTENANCE

Cutting Blades

In order to attain the best mowing effect, it is important that the blades are well sharpened and not damaged. Bent or cracked blades or blades with large nicks should be replaced.

IMPORTANT INFORMATION

The sharpening of blades should be carried out by an authorized service workshop.

Damaged blades should be replaced when hitting obstacles that result in a breakdown. Let the service workshop decide whether the blade can be repaired/ground or must be replaced.

Balance the blades after sharpening.

Check the blade mounts.



WARNING!

Blades are sharp. Protect your hands with gloves and/or wrap blades with a heavy cloth when handling.



Blade replacement

1. Remove blade bolt by turning counterclockwise.
2. Install new or resharpened blade with stamped "GRASS SIDE" facing towards ground/grass (down) or "THIS SIDE UP" facing deck and cutter housing.
3. Install and tighten blade bolt securely.
4. Torque blade bolt to 90 ft/lbs (122 Nm).

IMPORTANT INFORMATION

Special blade bolt is heat treated.

Replace with a Dixon bolt if required.

Do not use lower grade hardware than specified.

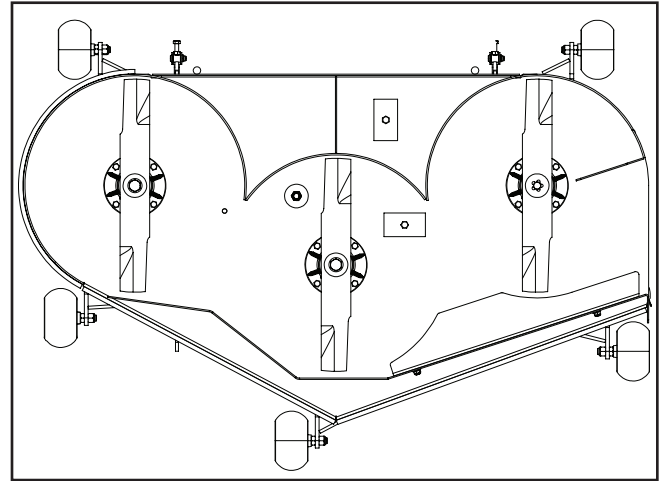

Check the blades

8011-604-1

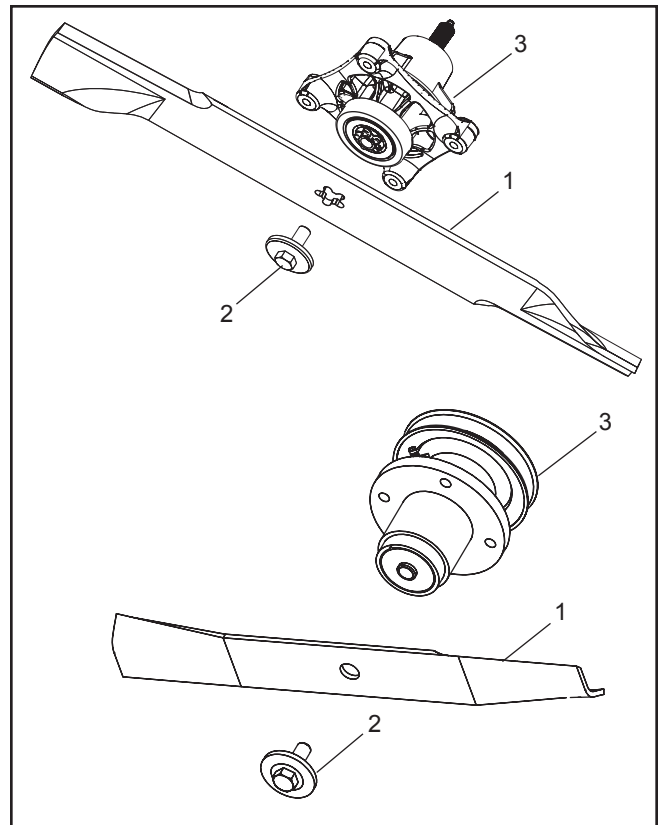

1. Blade
2. Blade bolt (special)
3. Cutter housing

Blade attachment

8053-027

MAINTENANCE

Adjusting the Mower Deck

Deck Leveling

Adjust the deck while the mower is on a level surface. Make sure the tires are inflated to the correct pressure. See “Technical Data” under Transmission. If tires are under or over inflated, the deck cannot be properly adjusted.

The deck should be adjusted slightly higher in the rear.

NOTE: To insure accuracy of leveling procedure, mower deck drive belt must be installed prior to leveling deck.

1. Wear heavy gloves. Turn each outer blade tip to align with the deck or in a side-to-side manner.
2. Measure from the floor surface up to the bottom of the blade tip on the discharge side of the mower deck. Retain this measurement.
3. Move to the opposite side, check that measurement is the same. If adjustment is required—with a $\frac{3}{4}$ " or adjustable wrench, turn the lift link adjustment nuts on either side counter clockwise to lower or clockwise to raise. Adjust until both side-to-side measurements are equal.

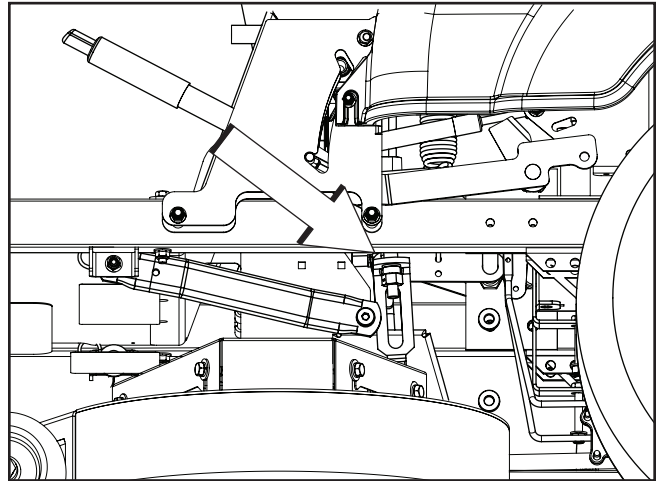

8058-030

Lift link adjustment nut

4. Turn any blade to align with the deck in front-to-rear manner. If the rear blade tip does not measure $\frac{1}{8}$ " to $\frac{1}{2}$ " higher, follow the front adjustment instructions that follow.
5. With a $\frac{5}{8}$ " or adjustable wrench, turn the nuts on the front suspension linkage. Clockwise raises the front of the mower, counter clockwise will lower the front. Adjust nuts until rear of mower deck is positioned level to $\frac{1}{8}$ " higher in the rear than the side-to-side measurement.

NOTE: This will place the mower deck in a base measurement position. Additional adjustment may be required to achieve desired cut for the type of grass or conditions being mowed.

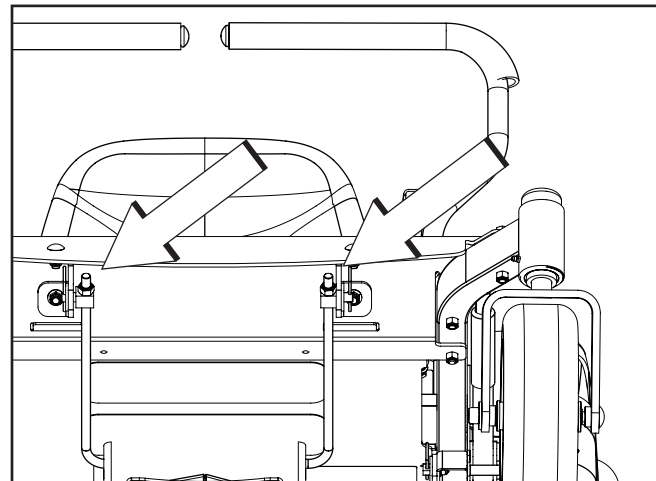

8058-031

Deck front adjustment nuts

MAINTENANCE

Anti-scalp rollers

Anti-scalp rollers are properly adjusted when they are just slightly off of the ground when the deck is at the desired cutting height in the operating position.

Anti-scalp rollers then keep the deck in the proper position to help prevent scalping in most terrain conditions.

IMPORTANT INFORMATION

Adjust anti-scalp rollers with the mower on a flat level surface.

The **anti-scalp rollers** can be set in three positions:

- Upper position 1½ to 2½" (38 to 64 mm) grass
- Middle position 2½ to 4" (64 to 102 mm) grass
- Lower position 4" to 6" (102 to 128 mm) grass.

The rollers should be approximately ¼" (6.5 mm) from ground. Do not adjust the rollers to support the deck.

Caster Wheels

Check every 200 hours. Check that wheels rotate freely. If wheels do not rotate freely take the unit to your dealer for service.

Foam filled tires or solid tires will void the warranty.

IMPORTANT INFORMATION

DO NOT add any type of tire liner or foam fill material to the tires. Excessive loads created by foam filled tires will cause premature failures.

Only use O.E.M. specified tires.

Removal and installation of caster wheel

Remove nut and caster bolt.

Pull the wheel out of the yoke and take care of the spacers.

Install in reverse order. Tighten caster bolt.

Hardware

Check daily. Inspect the entire machine for loose or missing hardware.

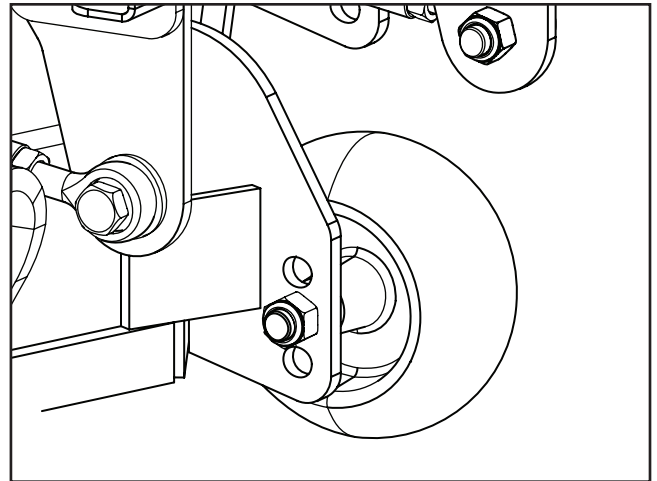

8050-830

Anti-scalp rollers

IMPORTANT INFORMATION

The anti-scalp rollers must not be used for gauge wheels or the roller and deck may be damaged.

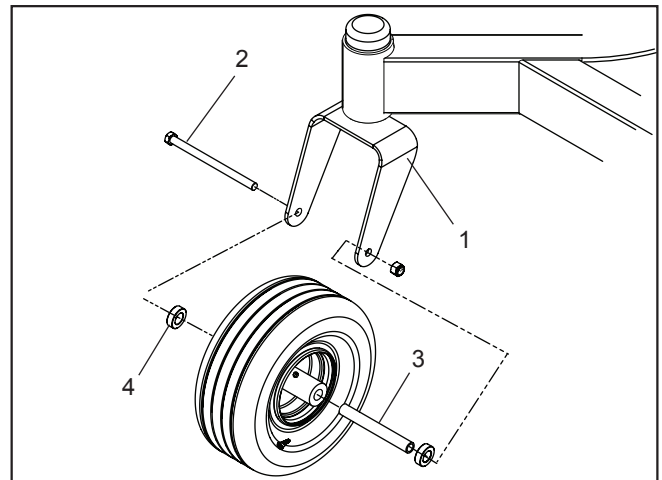

8011-619-4

1. Caster yoke
2. Caster bolt
3. Caster long spacer
4. Caster small spacers

Caster wheels

MAINTENANCE

Cleaning

Regular cleaning and washing, especially under the mower deck, will increase the machine's life-span. Make it a habit to clean the machine directly after use (after it is cooled), before the dirt sticks.

Do not spray water on the top of the mower deck. Use compressed air to clean the top side of mower deck. Regularly clean deck and underside of the deck with normal water pressure. Do not use a high pressure washer or steam cleaner. Avoid spraying engine and electrical components with water

Do not rinse hot surfaces with cold water. Let unit cool before washing.

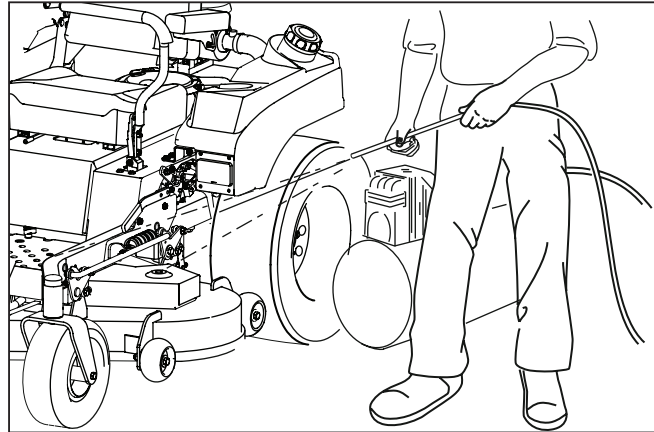

8050-831

Clean regularly



IMPORTANT INFORMATION

Use protective glasses when cleaning and washing.

LUBRICATION

Lubrication Schedule

12/12	1/52	1/365		25h	50h	100h	200h	300h
				(2x)				
				(2x)				
				(2x)				
		5						
				6				

8050-836

12/12 Every year 1/52 Every Week 1/365 Every day	Lubricate with grease gun Oil change Filter change	Lubricate with oil can Level check
--	--	---------------------------------------

General

Remove the ignition key to prevent unintentional movements during lubrication.

When lubricating with an oil can, it must be filled with engine oil.

When lubricating with grease, unless otherwise stated, use a high grade molybdenum disulphide grease.

For daily use, the machine should be lubricated twice weekly.

Wipe away excess grease after lubrication.

It is important to avoid getting lubricant on the belts or the drive surfaces on the belt pulleys. Should this happen, attempt to clean them with spirits. If the belt continues to slip after cleaning, it must be replaced. Gasoline or other petroleum products must not be used to clean belts.

LUBRICATION

Front Wheel Mount

Lubricate with a grease gun, one zerk for each wheel mount, until the grease is forced out.

Use only good quality bearing grease.

Grease from well-known brand names (petrochemical companies) usually maintains a good quality.

Front Wheel Bearings

Lubricate with a grease gun, one zerk for each set of wheel bearings, until the grease is forced out.

Use only good quality bearing grease.

IMPORTANT INFORMATION

Use minimal lubrication and remove excess lubricant so that it does not come into contact with belts or belt pulley drive surfaces.

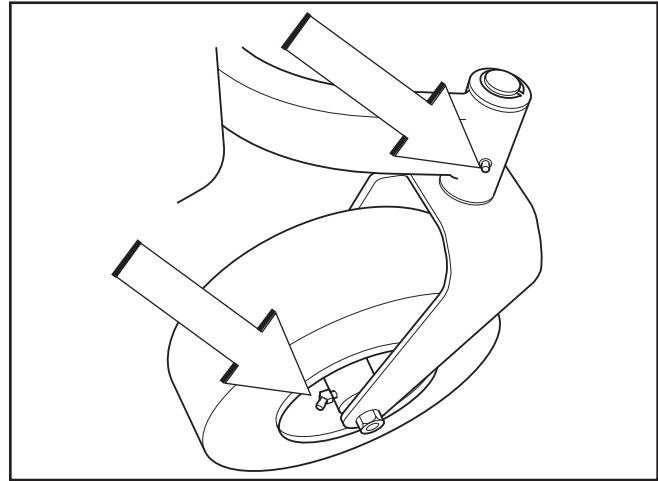

8011-731

Lubricating the front wheels

Deck Spindle

Lower the cutting deck completely.

If a grease gun without a rubber hose is used, the foot plate must be removed.

Lubricate with a grease gun, one zerk, 2-3 strokes.

Use only good quality bearing grease.

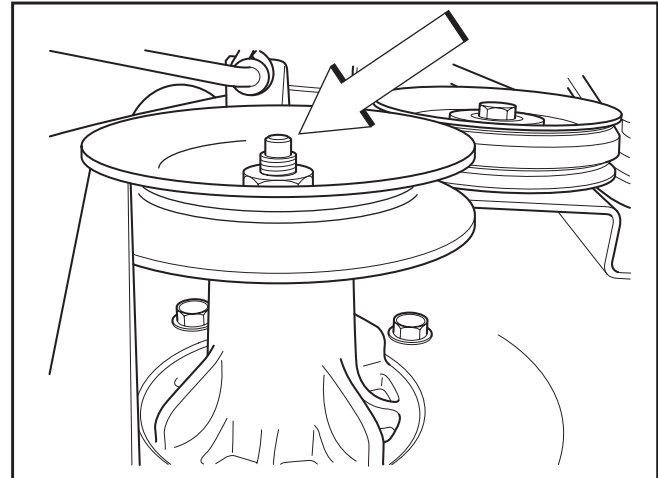

8011-732

Deck spindle

Deck Outer Spindle

Lubricate using a grease gun, one zerk, each side 2-3 strokes. Use only good quality bearing grease.

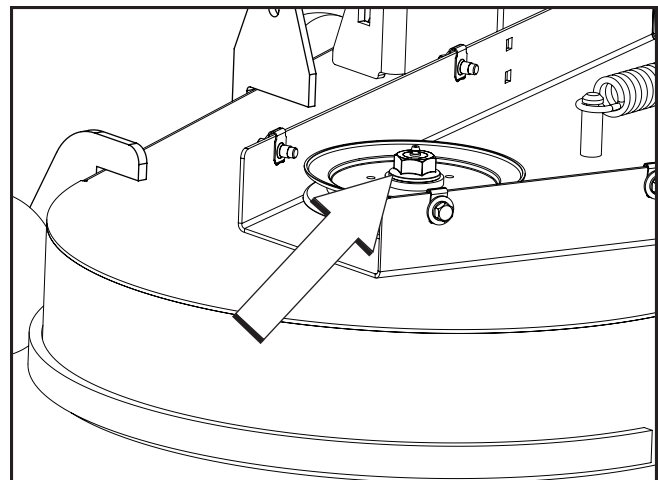

8061-025

Deck outer spindle (with belt shield removed)

LUBRICATION

Engine Oil



WARNING!

Engine oil can be very hot if it is drained directly after stopping the engine. Allow the engine to cool to a safe temperature before draining.

Engine Oil Filter

- Drain the engine oil in accordance with the work description under the heading Engine Oil/Change Engine Oil.
- Remove the oil filter. If necessary, use a filter remover.
- Wipe new, clean engine oil onto the seal for the new filter.
- Mount the filter by hand with $+3/4$ turn.
- Run the engine warm, then check that there are no leaks around the oil filter seal.
- Check the oil level in the engine, fill if necessary. The oil filter holds 0.1 qt (0.1 liters) of oil.

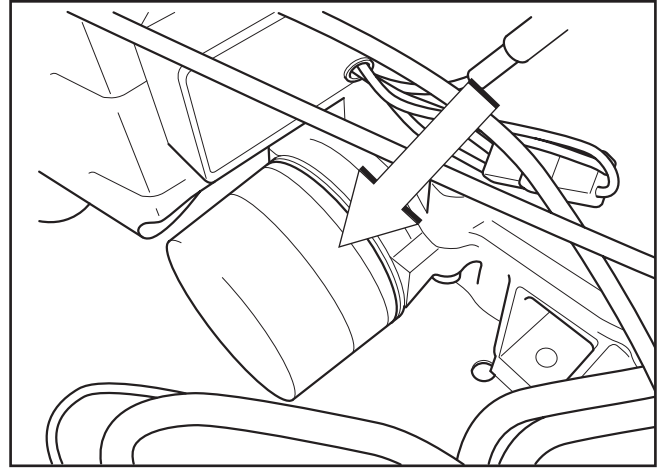

8011-734

Changing the oil filter

IMPORTANT INFORMATION

Used engine oil is a health hazard and must not be disposed of on the ground or in nature; it should always be disposed of at a workshop or appropriate disposal location.

Avoid skin contact; wash with soap and water in case of spills.

Engine Oil Levels

Check the oil level in the engine when the machine is standing level and the engine is stopped.

Remove the dipstick, wipe it clean, and then replace it. The dipstick should be screwed into place.

Take the dipstick out again and read the oil level.

The oil level should lie between the markings on the dipstick. If the level is approaching the "ADD" mark, fill the oil to the "FULL" mark on the dipstick.

Never fill to above the "FULL" mark.

The oil is filled through the hole for the dipstick.

API class SF, SG, SH, SJ or higher must be used.

Synthetic oil SAE 5W-30 or 10W-30 is recommended at all temperatures. Mineral oil SAE 5W-30, 10W-30 can be used between $-18^{\circ}\text{C}/0^{\circ}\text{F}$ and $+75^{\circ}\text{C}/40^{\circ}\text{F}$. At temperature above $+5^{\circ}\text{C}/40^{\circ}\text{F}$ single grade SAE 30 must be used.

See the Technical Data section for oil amounts.

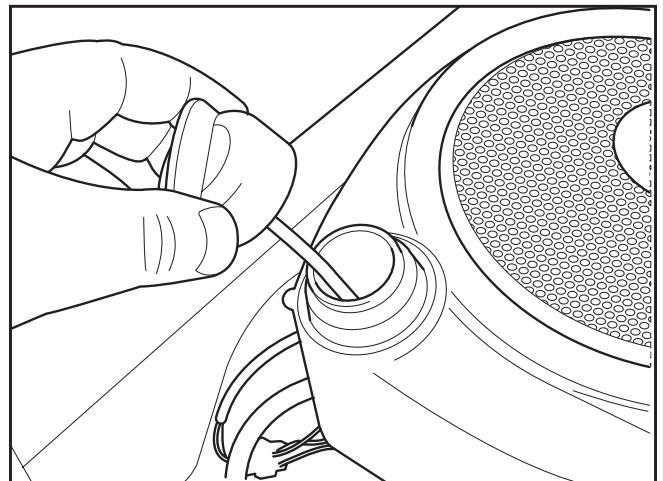

8011-500

Remove the dipstick

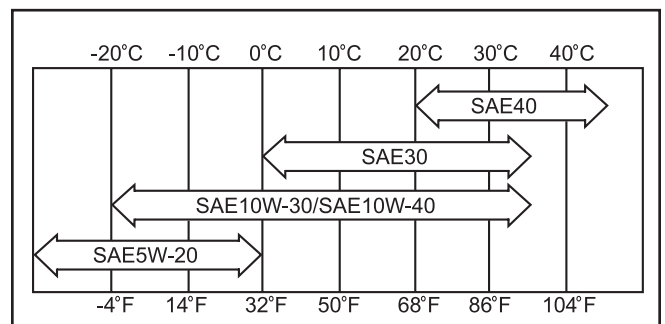

DIXON-53

LUBRICATION

Changing the Engine Oil

The engine oil should be changed for the first time after 5-8 hours of operation. Thereafter, it should be changed every 50 hours. The oil drain valve is located on the left side of the unit, below the oil filter.

- Place the machine on a flat surface.
- Place a container under the engine where the oil drain valve exits.
- Remove the valve cap.
- Allow the oil to run out into the container.
- Reinstall the oil drain valve cap.
- Replace the oil filter if necessary.
- Fill with new engine oil in accordance with Checking the Oil Level.
- Start the engine. Run it for 3-5 minutes. Stop and recheck the oil level.

Cables

If possible, grease both ends of the cables and move the controls to end stop positions when lubricating. Refit the rubber covers on the cables after lubrication. Cables with sheaths will bind if they are not lubricated regularly. If a cable binds, it can disrupt operation.

If a cable binds, remove the cable and hang it vertically. Lubricate it with light engine oil until the oil begins to escape from the bottom.

Tip: Fill a small plastic bag with oil and tape it so that it seals against the sheath and allow the cable to hang vertically from the bag overnight. If you do not succeed in lubricating the cable, it must be replaced.

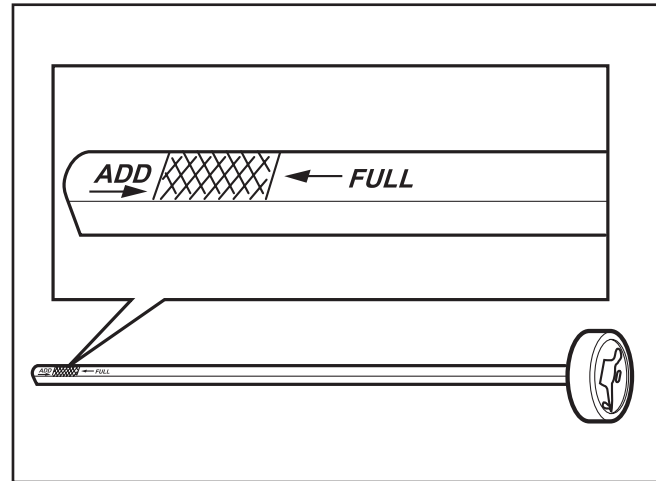

8009-159

The dipstick markings

TROUBLE SHOOTING

Problem	Cause
Engine will not start	<ul style="list-style-type: none">• Blade switch is engaged.• Steering controls are not locked in the neutral position• Parking brake is not activated• Battery is dead• Contamination in the carburetor or fuel line.• Fuel supply is closed or the shutoff valve for the fuel tank is in the wrong position• Clogged fuel filter or fuel line• Ignition system faulty
Starter does not turn the engine over	<ul style="list-style-type: none">• Battery is dead• Poor contact of the battery terminal cable connections• Blown fuse• Fault in the starter safety circuit. See Checking the Safety System in the "Maintenance Section"
Engine runs rough	<ul style="list-style-type: none">• Faulty carburetor• Choke control is pulled out with a warm engine• Clogged fuel filter or jet• Clogged ventilation valve on the fuel cap• Fuel tank nearly empty• Fouled spark plugs• Rich fuel mixture or fuel-air mixture.• Wrong fuel type• Water in fuel• Clogged air filter
Engine seems weak	<ul style="list-style-type: none">• Clogged air filter• Fouled spark plugs• Carburetor incorrectly adjusted• Air trapped in hydraulic system
Machine vibrates	<ul style="list-style-type: none">• Blades are loose• Blades are incorrectly balanced• Engine is loose

TROUBLE SHOOTING

Problem	Cause
Engine overheats	<ul style="list-style-type: none">• Clogged air intake or cooling fins• Engine overloaded• Poor ventilation around engine• Defective engine speed regulator• Too little or no oil in the engine• Contamination in the carburetor or fuel line.• Fouled spark plugs
Battery not charging	<ul style="list-style-type: none">• Poor contact of the battery terminal cable connections• Charging lead is disconnected
The machine moves slowly, unevenly, or not at all	<ul style="list-style-type: none">• Parking brake on• Bypass valve on pump open• Drive belt for the transmission slack or has come off• Air trapped in hydraulic system
Mower deck not engaging	<ul style="list-style-type: none">• Drive belt for the mower deck has come loose• Contact for the electromagnetic coupling has loosened• Blade switch is faulty or has come loose from cable contact• Blown fuse
Transaxle leaks oil	<ul style="list-style-type: none">• Damaged seals, housing, or gaskets• Air trapped in hydraulic system
Uneven mowing results	<ul style="list-style-type: none">• Different air pressure in tires on the left and right sides.• Bent blades• Suspending for the mower deck is uneven• Blades are dull• Driving speed too high• Grass is too long• Grass collected under the mower deck

STORAGE

Winter Storage

At the end of the mowing season, the machine should be readied for storage (or if it will not be in use for longer than 30 days). Fuel allowed to stand for long periods of time (30 days or more) can leave sticky residues that can plug the carburetor and disrupt engine function.

Fuel stabilizers are an acceptable option as regards to the sticky residues that can occur during storage.

Add stabilizer to the fuel in the tank or in the storage container. Always use the mixing ratios specified by the manufacturer of the stabilizer. Run the engine for at least 10 minutes after adding the stabilizer so that it reaches the carburetor. Do not empty the fuel tank and the carburetor if you have added stabilizer



WARNING!

Never store an engine with fuel in the tank indoors or in poorly ventilated spaces where fuel vapor can come in contact with open flames, sparks, or a pilot light such as in a boiler, hot water tank, clothes drier, etc. Handle the fuel with care. It is very flammable and can cause serious personal injury and property damage. Drain the fuel into an approved container outdoors and far away from open flame. Never use gasoline for cleaning. Use a degreaser and warm water instead.

To ready the machine for storage, follow these steps:

1. Thoroughly clean the machine, especially under the mower deck. Touch up damage to the paint and spray a thin layer of oil on the underside of the mower deck to avoid corrosion.
2. Inspect the machine for worn or damaged parts and tighten any nuts or screws that may have become loose.
3. Change the engine oil; dispose of properly.
4. Empty the fuel tanks or add a fuel stabilizer. Start the engine and allow it to run until the carburetor is drained of fuel or the stabilizer has reached the carburetor.
5. Remove the spark plug and pour about a tablespoon of engine oil into the cylinder. Turn over the engine so that the oil is evenly distributed and then refit the spark plug.
6. Lubricate all grease zerks, joints, and axles.
7. Remove the battery. Clean, charge, and store the battery in a cool place, but protect it from direct cold.
8. Store the machine in a clean, dry place and cover it for extra protection.

Service

When ordering spare parts, please specify the purchase year, model, type, and serial number.

Always use genuine Dixon spare parts.

An annual check-up at an authorized service workshop is a good way to ensure that your machine performs its best the following season.

SCHEMATIC

- NOTE:
1. SEAT UNOCCUPIED
 2. BRAKE SWITCH IN OFF POSITION
 3. MOTION CONTROL LEVERS OUT
 4. PTO IN OFF POSITION

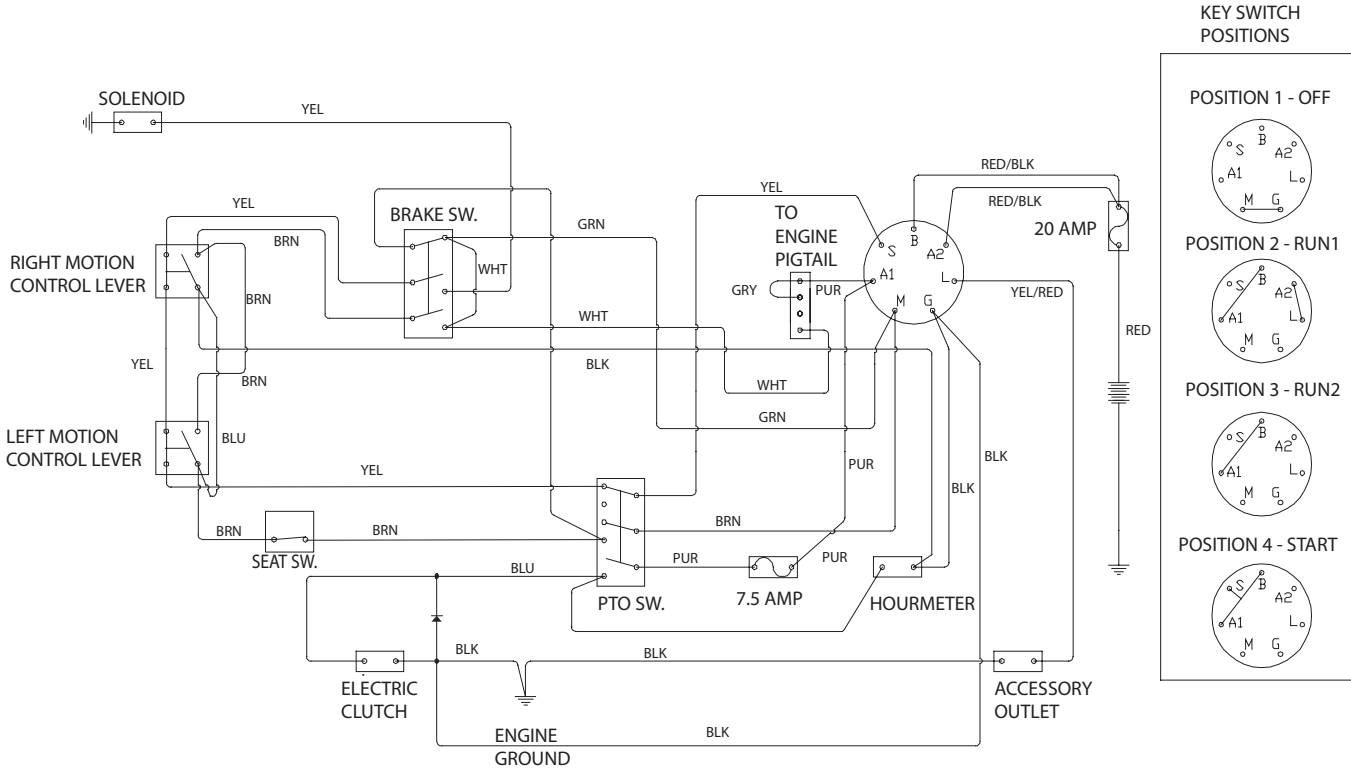

KEY SWITCH POSITIONS

POSITION 1 - OFF

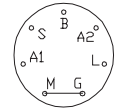

POSITION 2 - RUN1

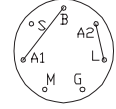

POSITION 3 - RUN2

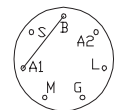

POSITION 4 - START

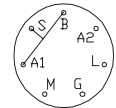

TECHNICAL DATA

Accessories

Collection system

Torque Specifications

Engine crankshaft bolt	50 ft/lb (67 Nm)	Standard 1/4" fasteners	9 ft/lb (12 Nm)
Deck pulley bolts	150 ft/lb (203 Nm)	Standard 5/16" fasteners	18 ft/lb (25 Nm)
Lug nuts	75 ft/lb (100 Nm)	Standard 3/8" fasteners	33 ft/lb (44 Nm)
Blade bolt	90 ft/lb (122 Nm)	Standard 7/16" fasteners	52 ft/lb (70 Nm)
		Standard 1/2" fasteners	80 ft/lb (110 Nm)

HEX HEAD CAP SCREWS

The torque values shown should be used as a general guideline when specific torque values are not given.

U.S. Standard Hardware

Grade	SAE Grade 5			SAE Grade 8		Flangelock Screw w/Flangelock Nut	
	ft./lbs	ft./lbs	Nm	ft./lbs	Nm	ft./lbs	Nm
Shank Size (Diameter in inches, fine or coarse thread)	1/4	9	12	13	18		
	5/16	18	24	28	38	24	33
	3/8	31	42	46	62	40	54
	7/16	50	68	75	108		
	1/2	75	102	115	156		
	9/16	110	150	165	224		
	5/8	150	203	225	305		
	3/4	250	339	370	502		
	7/8	378	513	591	801		
	1 1/8	782	1060	1410	1912		

** Grade 5 - Minimum commercial quality (lower quality not recommended)

Metric Standard Hardware

Grade	Grade 8.8		Grade 10.9		Grade 12.9		
	ft./lbs	ft./lbs	Nm	ft./lbs	Nm	ft./lbs	Nm
Shank Size (Diameter in millimeters, fine or coarse thread)	M4	1.5	2	2.2	3	2.7	3.6
	M5	3	4	4.5	6	5.2	7
	M6	5.2	7	7.5	10	8.2	11
	M7	8.2	11	12	16	15	20
	M8	13.5	18	18.8	25	21.8	29
	M10	24	32	35.2	47	43.5	58
	M12	43.5	58	62.2	83	75	100
	M14	70.5	94	100	133	119	159
	M16	108	144	147	196	176	235
	M18	142	190	202	269	242	323
	M20	195	260	275	366	330	440
	M22	276	368	390	520	471	628
	M24	353	470	498	664	596	794
	M27	530	707	474	996	904	1205

TECHNICAL DATA

	SPEEDZTR 44 / 965981001	SZ4619 / 965882001
Engine		
Manufacturer	Kawasaki	Briggs & Stratton
Type	FH541V	Intek
Power	17 hp*	19.5 hp*
Lubrication	Pressure with oil filter	Pressure with oil filter
Oil capacity excluding filter	1.8 qt (1.7 liters)	1.34 qts (1.27 liters)
Oil capacity including filter	1.9 qt (1.8 liters)	1.46 qt (1.35 liters)
Engine oil, Synthetic Engine oil, Mineral Class	SAE 10W30, 10W40, SAE 30, SAE 40 API SF-SJ	SAE 10W30, 10W40, 5W20 5W30 API, SF-SG
Fuel	Min 86 octane, unleaded (Max methanol 10%, max MTBE 15%)	Min 87 octane, unleaded (Max methanol 10%, max MTBE 15%)
Fuel tank capacity	4.5 gallon (17 liters)	4.5 gallon (17 liters)
Spark plugs/gap	Champion RCJ8Y .030" / 0.75 mm	Champion RC12YC .030" / 0.75 mm
Cooling	Air cooling	Air cooling
Air filter	Standard	Standard
Alternator	12V 16A	12V 16A
Starter	Electric 12V	Electric 12V
Transmission		
Type	Dual Hydro-Gear EZT	Dual Hydro-Gear EZT
Speed and direction controls	Dual levers, foam gripped	Dual levers, foam gripped
Speed forward	0-9.5 mph / 15.3 km/h	0-6 mph / 0-9.7 km/h
Speed reverse	0-5 mph / 0-8 km/h	0-3.5 mph / 0-5.6 km/h
Brakes	Mechanical parking brake	Mechanical parking brake
Front caster tires, smooth tread	11 x 3-7, 4 ply	11 x 3-7, 4 ply
Rear tires, turf pneumatic	18 x 7.5-8	18 x 8.5-8
Tire pressure, front and rear	15 PSI / 103 kPa / 1 bar	15 PSI / 103 kPa / 1 bar

TECHNICAL DATA

	ZTR 44 / 965981001	SZ4619 / 965882001
Equipment		
Cutting width	44" / 111.8 cm	46" / 116.8
Cutting height	1.5" - 4" / 2.5 cm - 10.6 cm	1.5" - 4" / 2.5 cm - 10.6 cm
Uncut circle	0	0
Number of blades	2	3
Blade length	14.97" / 38.02	22.73" / 57.73
Nose rollers	No	No
Sprung seat	Standard	Standard
Hinged armrests	Yes	Yes
Blade engagement	Electric clutch	Electric clutch
Deck construction	11 gauge w/10 gauge skirts	Stamped
Productivity		
Output	2.26 acres/hr / 9173 m ² /hr	2.37 acres/hr / 9591 m ² /hr
Overall dimensions		
Weight	510 lbs / 231 kg	525 lbs / 238 kg
Base machine length	75" / 191cm	75" / 191cm
Base machine width	40" 102cm	40" 102cm
Base machine height	41 ³ / ₄ " / 106 cm	41 ³ / ₄ " / 106 cm
Overall width, chute up	46" / 116 cm	48" / 122 cm
Overall width, chute down	54" / 137 cm	56" / 142 cm

TECHNICAL DATA

	SZ5422 / 965882101	ZTR 36 / 965882201
Engine		
Manufacturer	Briggs & Stratton	Briggs & Stratton
Type	ELS	Intek
Power	22 hp*	19.5 hp*
Lubrication	Pressure with oil filter	Pressure with oil filter
Oil capacity excluding filter	1.78 qt (1.68 liters)	1.34 qts (1.27 liters)
Oil capacity including filter	2 qt (1.89 liters)	1.46 qt (1.35 liters)
Engine oil, Synthetic Engine oil, Mineral Class	SAE 10W30, 10W40, 5W20 5W30 API, SF-SG	SAE 10W30, 10W40, 5W20 5W30 API, SF-SG
Fuel	Min 87 octane, unleaded (Max methanol 10%, max MTBE 15%)	Min 87 octane, unleaded (Max methanol 10%, max MTBE 15%)
Fuel tank capacity	4.5 gallon (17 liters)	4.5 gallon (17 liters)
Spark plugs/gap	Champion RC12YC .030" / 0.75 mm	Champion RC12YC .030" / 0.75 mm
Cooling	Air cooling	Air cooling
Air filter	Standard	Standard
Alternator	12V 16A	12V 16A
Starter	Electric 12V	Electric 12V
Transmission		
Type	Dual Hydro-Gear EZT	Dual Hydro-Gear EZT
Speed and direction controls	Dual levers, foam gripped	Dual levers, foam gripped
Speed forward	0-6 mph / 0-9.7 km/h	0-6 mph / 0-9.7 km/h
Speed reverse	0-3.5 mph / 0-5.6 km/h	0-3.5 mph / 0-5.6 km/h
Brakes	Mechanical parking brake	Mechanical parking brake
Front caster tires, smooth tread	11 x 4-5, 4 ply	11 x 4-5, 4 ply
Rear tires, turf pneumatic	18 x 9.5-8	18 x 7.5-8
Tire pressure, front and rear	15 PSI / 103 kPa / 1 bar	15 PSI / 103 kPa / 1 bar

*As rated by the engine manufacturer

TECHNICAL DATA

	SZ5422 / 965882101	ZTR 36 / 965882201
Equipment		
Cutting width	54"	36"
Cutting height	1.5" - 4" / 2.5 cm - 10.6 cm	1.5" - 4" / 2.5 cm - 10.6 cm
Uncut circle	0	0
Number of blades	2	2
Blade length	18.25"	18.5"
Nose rollers	No	No
Sprung seat	Standard	Standard
Hinged armrests	No	Yes
Blade engagement	Electric clutch	Electric clutch
Deck construction	Stamped	11 gauge w/10 gauge skirts
Productivity		
Output	2.78 acres/hr / 11250 m ² /hr	1.85 acres/hr / 7487 m ² /hr
Overall dimensions		
Weight	538 lbs / 244 kg	498 lbs / 225 kg
Base machine length	75" / 191 cm	75" / 191 cm
Base machine width	40" 102 cm	40" 102 cm
Base machine height	43 ³ / ₄ " / 112 cm	43 ³ / ₄ " / 112 cm
Overall width, chute up	57" / 145 cm	40 ¹ / ₂ " / 103 cm
Overall width, chute down	67 ¹ / ₂ " / 171 cm	51" / 130 cm

TECHNICAL DATA

	ZTR 44 / 965882301	ZTR 48 / 965882401
Engine		
Manufacturer	Briggs & Stratton	Kohler
Type	Intek	Courage
Power	19.5 hp*	24 hp*
Lubrication	Pressure with oil filter	Pressure with oil filter
Oil capacity excluding filter	1.34 qts (1.27 liters)	
Oil capacity including filter	1.46 qt (1.35 liters)	1.6 qt (1.5 liters)
Engine oil, Synthetic Engine oil, Mineral Class	SAE 10W30, 10W40, 5W20 5W30 API, SF-SG	SAE 10W30, 10W40, 5W20 5W30 API, SF-SG
Fuel	Min 87 octane, unleaded (Max methanol 10%, max MTBE 15%)	Min 87 octane, unleaded (Max methanol 10%, max MTBE 15%)
Fuel tank capacity	4.5 gallon (17 liters)	4.5 gallon (17 liters)
Spark plugs/gap	Champion RC12YC .030" / 0.75 mm	NGK - BPR4ES .030" / 0.75 mm
Cooling	Air cooling	Air cooling
Air filter	Standard	Standard
Alternator	12V 16A	12V 16A
Starter	Electric 12V	Electric 12V
Transmission		
Type	Dual Hydro-Gear EZT	Dual Hydro-Gear EZT
Speed and direction controls	Dual levers, foam gripped	Dual levers, foam gripped
Speed forward	0-6 mph / 0-9.7 km/h	0-6 mph / 0-9.7 km/h
Speed reverse	0-3.5 mph / 0-5.6 km/h	0-3.5 mph / 0-5.6 km/h
Brakes	Mechanical parking brake	Mechanical parking brake
Front caster tires, smooth tread	11 x 4-5, 4 ply	11 x 4-5, 4 ply
Rear tires, turf pneumatic	18 x 8.5-8	18 x 8.5-8
Tire pressure, front and rear	15 PSI / 103 kPa / 1 bar	15 PSI / 103 kPa / 1 bar

TECHNICAL DATA

	ZTR 44 / 965882301	ZTR 48 / 965882401
Equipment		
Cutting width	44"	48"
Cutting height	1.5" - 4" / 2.5 cm - 10.6 cm	1.5" - 4" / 2.5 cm - 10.6 cm
Uncut circle	0	0
Number of blades	3	2
Blade length	14.97"	16.25"
Nose rollers	No	Yes
Michigan seat	Standard	Standard
Hinged armrests	Yes	Yes
Hour meter	Standard	Standard
Blade engagement	Electric clutch	Electric clutch
Deck construction	11 gauge w/10 gauge skirts	11 gauge w/10 gauge skirts
Productivity		
Output	2.26 acres/h / 9173 m ² /h	2.47 acres/h / 9996 m ² /h
Overall dimensions		
Weight	510 lbs / 231 kg	525 lbs / 238 kg
Base machine length	75" / 191cm	75" / 191cm
Base machine width	40" 102cm	40" 102cm
Base machine height	41 ³ / ₄ " / 106 cm	41 ³ / ₄ " / 106 cm
Overall width, chute up	46" / 116 cm	48" / 122 cm
Overall width, chute down	54" / 137 cm	56" / 142 cm

CONFORMITY CERTIFICATES

USA requirements

Labels are placed on the engine and/or in the engine compartment stating that the machine will fulfill the requirements. This is also applicable to special requirements for any of the states, (California emission rules etc.). Do not remove any of these labels. Certificates can also be supplied with the machine at delivery or written in the Engine manual. Take care of them as they are valuable documents.

CE requirements

The Declaration of Conformity is included in the literature packet.

WARRANTY

DIXON® ZTR® RESIDENTIAL SpeedZTR™ and RAM 42 Residential Mowers

DIXON WARRANTS ITS ZTR MOWERS AGAINST DEFECTS IN MATERIAL AND WORKMANSHIP FOR THE PERIODS SET FORTH BELOW. THE SOLE REMEDY UNDER THIS WARRANTY IS REPLACEMENT OR REPAIR OF PARTS INCLUDING LABOR COSTS.

THIS WARRANTY IS SUBJECT TO THE FOLLOWING CONDITIONS AND LIMITATIONS:

1. RESIDENTIAL WARRANTY (used only at owner's primary place of residence):
 - a. First two years - 100% parts and labor subject to the conditions and limitations described herein for a period of two years from date of purchase by the original owner.
 - b. Third year - limited to 100% parts cost as shown in the current Dixon Parts Price List and subject to the conditions and limitations as described herein.
 - c. Attachments marketed through or approved by Dixon are warranted for two years parts and labor in residential use applications.
2. NOT APPROVED FOR COMMERCIAL USE.
3. All Dixon warranty must be accomplished by authorized Dixon dealers and in accordance with Dixon warranty policy and allowances. All warranty claims must be submitted to Dixon for approval.
4. Warranty applies to new mowers.
5. Warranty labor reimbursement to dealers based on published Dixon flat rate schedule.
6. Warranty does not apply to damage in transit or incidents of misuse, negligence, accidents, or alteration. The use of parts or components other than those supplied by Dixon VOIDS ALL WARRANTY.
7. Battery warranty is limited to 1 year from mower manufacture date.
8. The following items are not covered by this warranty policy:
 - a. Routine maintenance or adjustments to include any oils, filters or other fluids used.
 - b. Belts, blades, tires and cosmetic appearance (paint, seat fade, etc.)
 - c. Pick up and delivery charges for transportation of mower to and from an authorized Dixon dealer's place of business.
 - d. Engines. These are covered under a separate warranty by each individual engine manufacturer. Consult engine manual for warranty details.
 - e. Any costs or expense of providing substitute equipment while repair work is being performed on a warranted mower.
9. THERE IS NO OTHER EXPRESS WARRANTY. TO THE EXTENT PERMITTED BY LAW, ALL IMPLIED WARRANTIES, INCLUDING THOSE OF MERCHANTABILITY AND FITNESS FOR A PARTICULAR PURPOSE ARE EXCLUDED, OTHERWISE, ALL SUCH IMPLIED WARRANTIES ARE LIMITED TO THE SAME DURATION AND REMEDIES AS THE EXPRESS WARRANTY. ALL LIABILITIES FOR CONSEQUENTIAL DAMAGES UNDER ANY EXPRESS OR IMPLIED WARRANTY ARE EXCLUDED.

SERVICE JOURNAL

Action	Date, mtr reading, stamp, sign
<p>After the First 5-8 Hours</p> <ol style="list-style-type: none">1. Change engine oil.	<input data-bbox="1052 373 1081 407" type="checkbox"/>

SERVICE JOURNAL

Action	Date, mtr reading, stamp, sign
<p>25-Hour Service</p> <ol style="list-style-type: none">1. Check the fuel pump's air filter.2. Sharpen/Replace mower blades if required.3. Check the tire pressures.4. Check battery with cables.5. Lubricate according to lubrication chart.6. Check/clean the engine's cooling air intake.7. Clean the air cleaner's pre-filter (foam).	

SERVICE JOURNAL

Action	Date, mtr reading, stamp, sign
<p>50-Hour Service</p> <ol style="list-style-type: none">1. Perform the 25-hour service.2. Clean/replace the air cleaner's filter cartridge (paper filter) (shorter intervals for dusty operating conditions).3. Change engine oil.4. Lubricate according to lubrication chart.5. Check/adjust the parking brake.	

SERVICE JOURNAL

Action	Date, mtr reading, stamp, sign
<p>100-Hour Service</p> <ol style="list-style-type: none">1. Perform the 25-hour service.2. Perform the 50-hour service.3. Change the engine oil filter.4. Clean/replace the spark plugs.5. Replace the fuel filter.6. Clean the cooling fins on the engine and transmission.7. Check V-belts.8. Check tighten caster wheel axle bolts (every 200 hours).9. Change the air filter's paper cartridge.	

SERVICE JOURNAL

Action	Date, mtr reading, stamp, sign
<p>300-Hour Service</p> <ol style="list-style-type: none">1. Inspect the machine. Come to agreement with the customer as to which additional work is to be carried out.2. Perform the 25-hour service.3. Perform the 50-hour service.4. Perform the 100-hour service.5. Check/adjust the mower deck.6. Clean the combustion chamber and grind the valve seats.7. Check the engine valve clearance.8. Replace the air cleaner's pre-filter (foam).	

SERVICE JOURNAL

Action	Date, mtr reading, stamp, sign
<p>At Least Once Each Year</p> <ol style="list-style-type: none">1. Clean the engine's cooling air intake (25 hours).2. Replace the air cleaner's pre-filter (foam) (300 hours).3. Replace the air filter's paper cartridge.4. Change the engine oil (50 hours).5. Replace the engine oil filter (100 hours).6. Check/adjust the cutting height.7. Check/adjust the parking brake (50 hours).8. Clean/Change the spark plugs (100 hours).9. Change the fuel filter (100 hours).10. Clean the cooling fins (100 hours).11. Check the engine valve clearance.12. Perform the 300-hour service at an authorized service workshop.	

DIXON ZTR[®]