

Poulan PRO

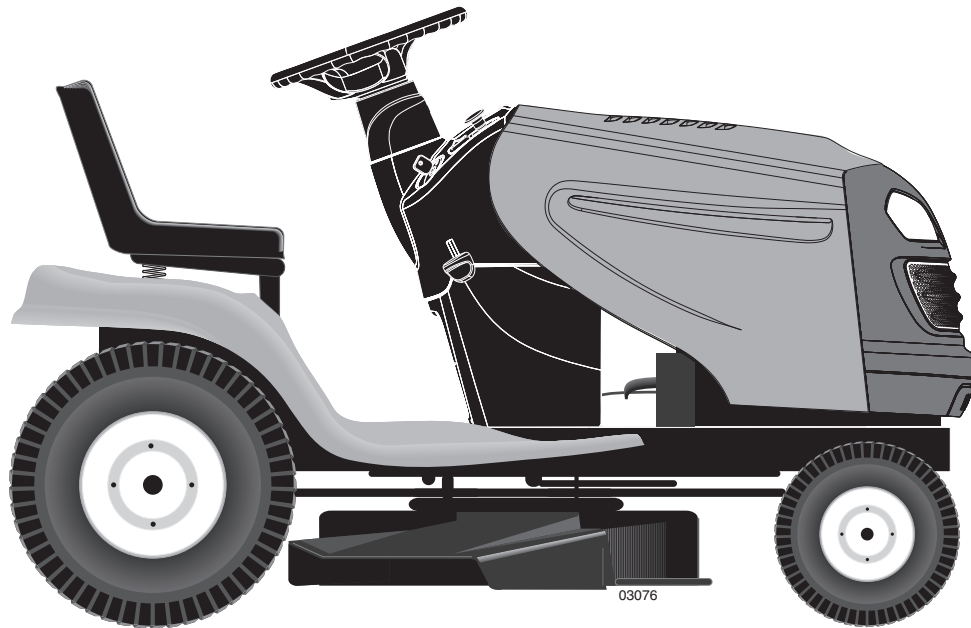

REPAIR PARTS MANUAL

MODEL:

PP21H42
LAWN TRACTOR

ALWAYS WEAR EYE PROTECTION DURING OPERATION

Visit our website: www.poulan-pro.com

⚠ WARNING:

Read this Manual and follow all Warnings and Safety Instructions. Failure to do so can result in serious injury.

HOW TO USE THIS MANUAL

This manual is designed to provide the customer with a means to identify the parts on his/her tractor when ordering repair parts. The illustrations may or may not represent the actual assemblies; therefore, it is not recommended to use this manual as a guide to assemble or disassemble the tractor. Some hardware and parts are drawn larger in order to more readily identify them.

Each tractor has its own model number.

The model number for your tractor can be found on the fender under the seat.

When ordering parts, always give the following information:

- Product - "Tractor"
- MODEL NUMBER - "PP21H42 (96011021801)"
- Part Number
- Part Description

TABLE OF CONTENTS

SCHEMATIC	3
ELECTRICAL.....	4-5
CHASSIS	6-7
DRIVE.....	8-9
ENGINE.....	10-11
SEAT	12-13
STEERING	14-15
MOWER DECK	16-17
MOWER LIFT.....	18
DECALS.....	19

TRACTOR - - MODEL NUMBER PP21H42 (96011021801), PRODUCT NO. 960 11 02-18 SCHEMATIC

SCH03

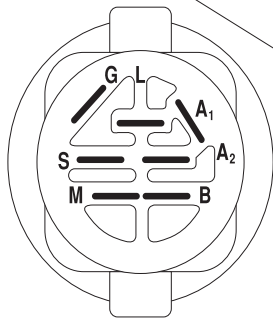
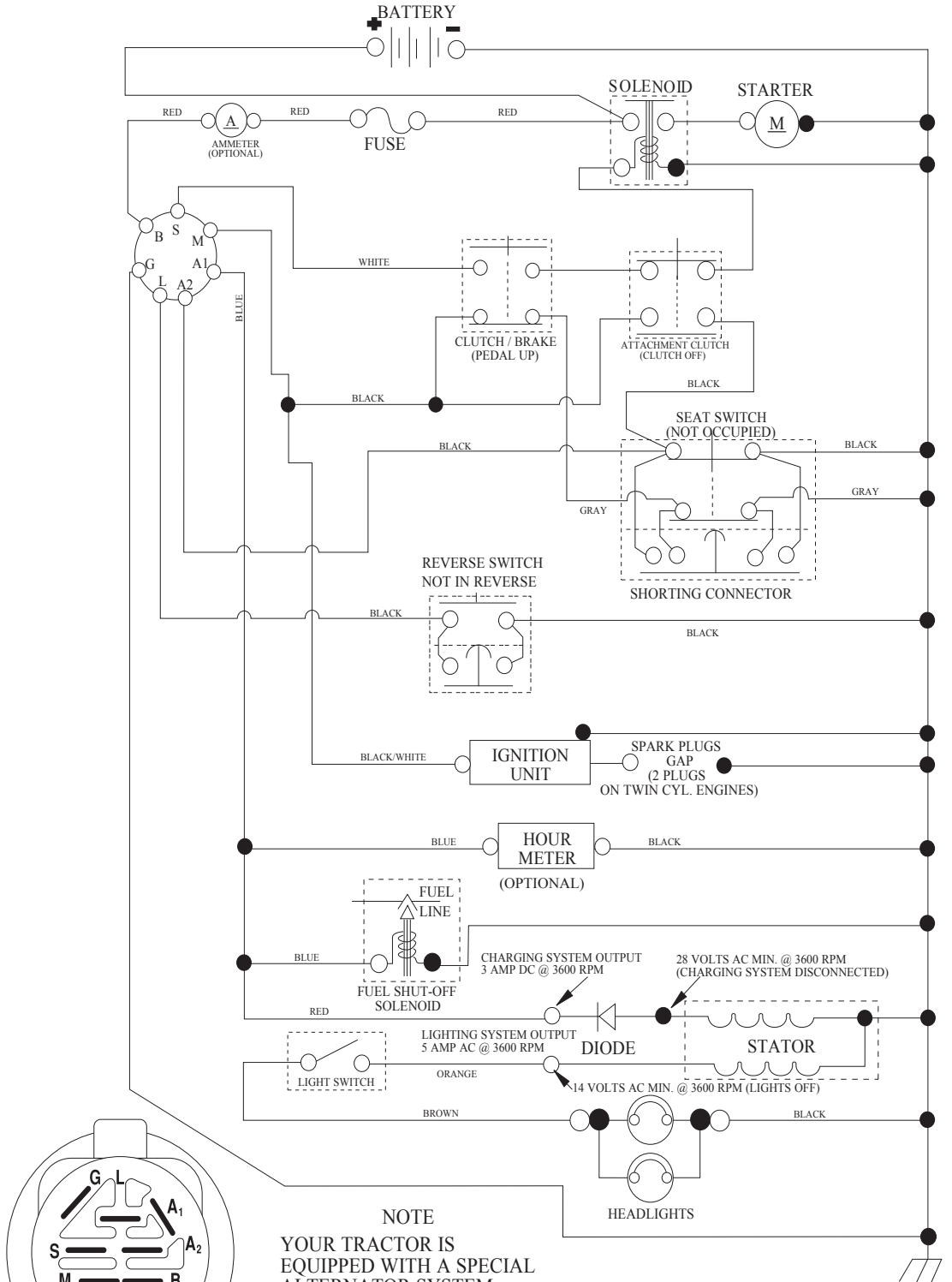

IGNITION SWITCH

POSITION	CIRCUIT	"MAKE"
OFF	M+G+A1	
RUN/OVERRIDE	B+A1	
RUN	B+A1	L+A2
START	B + S + A1	

NOTE
YOUR TRACTOR IS EQUIPPED WITH A SPECIAL ALTERNATOR SYSTEM. THE LIGHTS ARE NOT CONNECTED TO THE BATTERY, BUT HAVE THEIR OWN ELECTRICAL SOURCE. BECAUSE OF THIS, THE BRIGHTNESS OF THE LIGHTS WILL CHANGE WITH ENGINE SPEED. AT IDLE THE LIGHTS WILL DIM. AS THE ENGINE IS SPEEDED UP, THE LIGHTS WILL BECOME THEIR BRIGHTEST.

● NON-REMOVABLE CONNECTIONS
○ REMOVABLE CONNECTIONS

WIRING INSULATED CLIPS
NOTE: IF WIRING INSULATED CLIPS WERE REMOVED FOR SERVICING OF UNIT, THEY SHOULD BE RE-INSTALLED TO PROPERLY SECURE YOUR WIRING.

**TRACTOR - - MODEL NUMBER PP21H42 (96011021801), PRODUCT NO. 960 11 02-18
ELECTRICAL**

L09

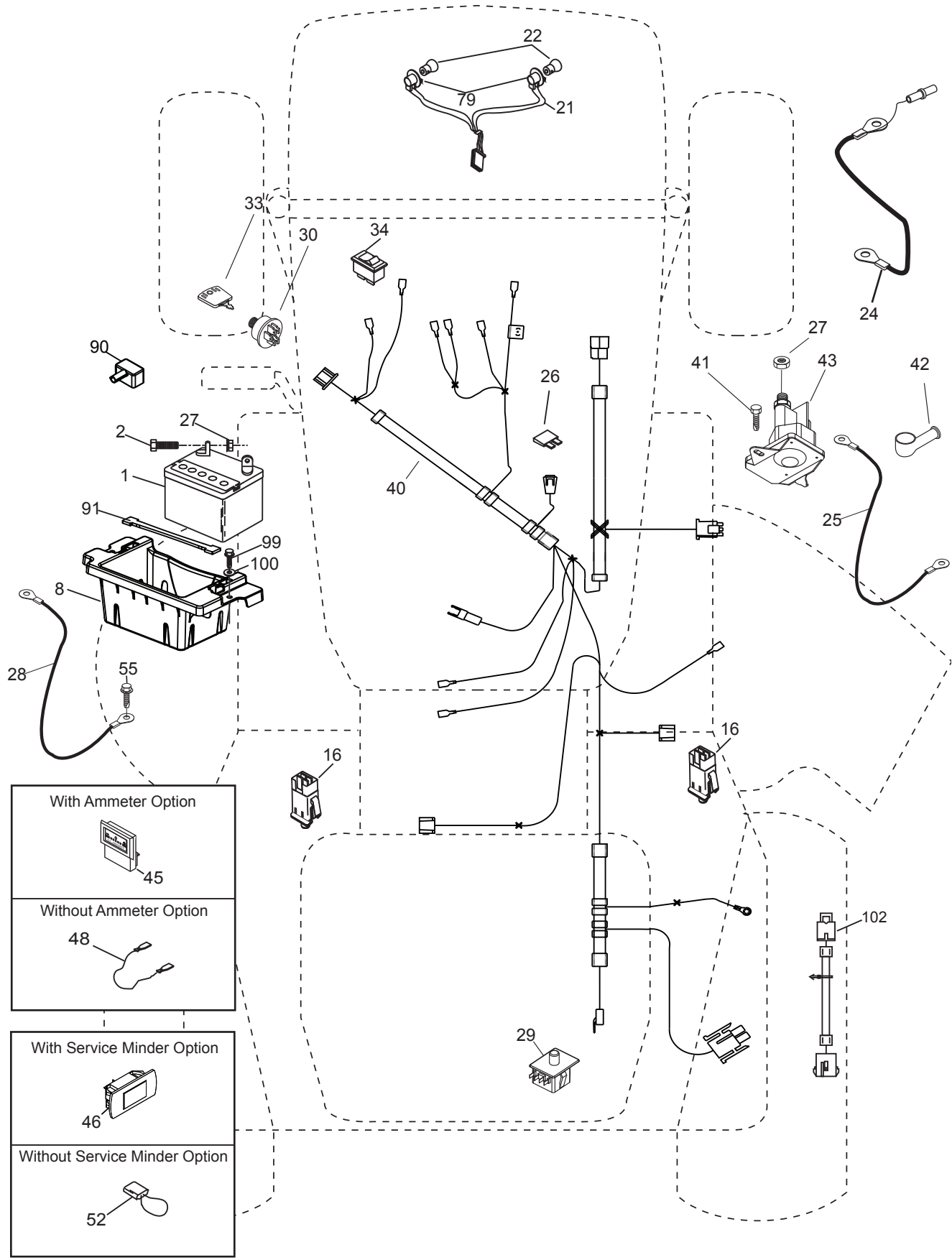

**TRACTOR - - MODEL NUMBER PP21H42 (96011021801), PRODUCT NO. 960 11 02-18
ELECTRICAL**

KEY PART NO. NO.	DESCRIPTION
1 532 16 34-65	Battery
2 874 76 04-12	Bolt Hex Hd 1/4-20 unc x 3/4
8 532 18 64-91	Box Battery
16 532 17 61-38	Switch Interlock
21 532 18 37-59	Harness Socket Light
22 532 00 41-52	Bulb, Light #1156
24 532 12 47-80	Cable Battery
25 532 14 61-48	Cable Battery
26 532 17 51-58	Fuse
27 873 51 04-00	Nut Keps Hex 1/4-20 unc
28 532 14 54-91	Cable Ground
29 532 19 27 49	Switch Seat
30 532 19 33-50	Switch Ign
33 532 41 19-33	Key/Chain
34 532 11 07-12	Switch Light/Reset
40 532 19 74-28	Harness Ign
41 871 11 04-08	Bolt Fin Hex 1/4-20 unc x 1/2
42 532 13 15-63	Cover Terminal Red
43 532 19 25-07	Solenoid
46 532 19 81-38	Gauge Hourmeter
48 532 14 08-44	Adapter Ammeter
55 817 49 05-08	Screw 5/16-18 x 1/2
79 532 17 52-42	Socket Asm. Bulb
90 532 18 04-49	Cover Terminal
91 532 19 02-70	Strap Battery
99 817 67 04-12	Screw 1/4-20 x 3/4
100 819 09 14-16	Washer 9/32 x 7/8 x 16 Ga.
102 532 19 74-60	Harness Pigtail Trans. ROS

NOTE: All component dimensions given in U.S. inches
1 inch = 25.4 mm

TRACTOR - - MODEL NUMBER PP21H42 (96011021801), PRODUCT NO. 960 11 02-18
CHASSIS

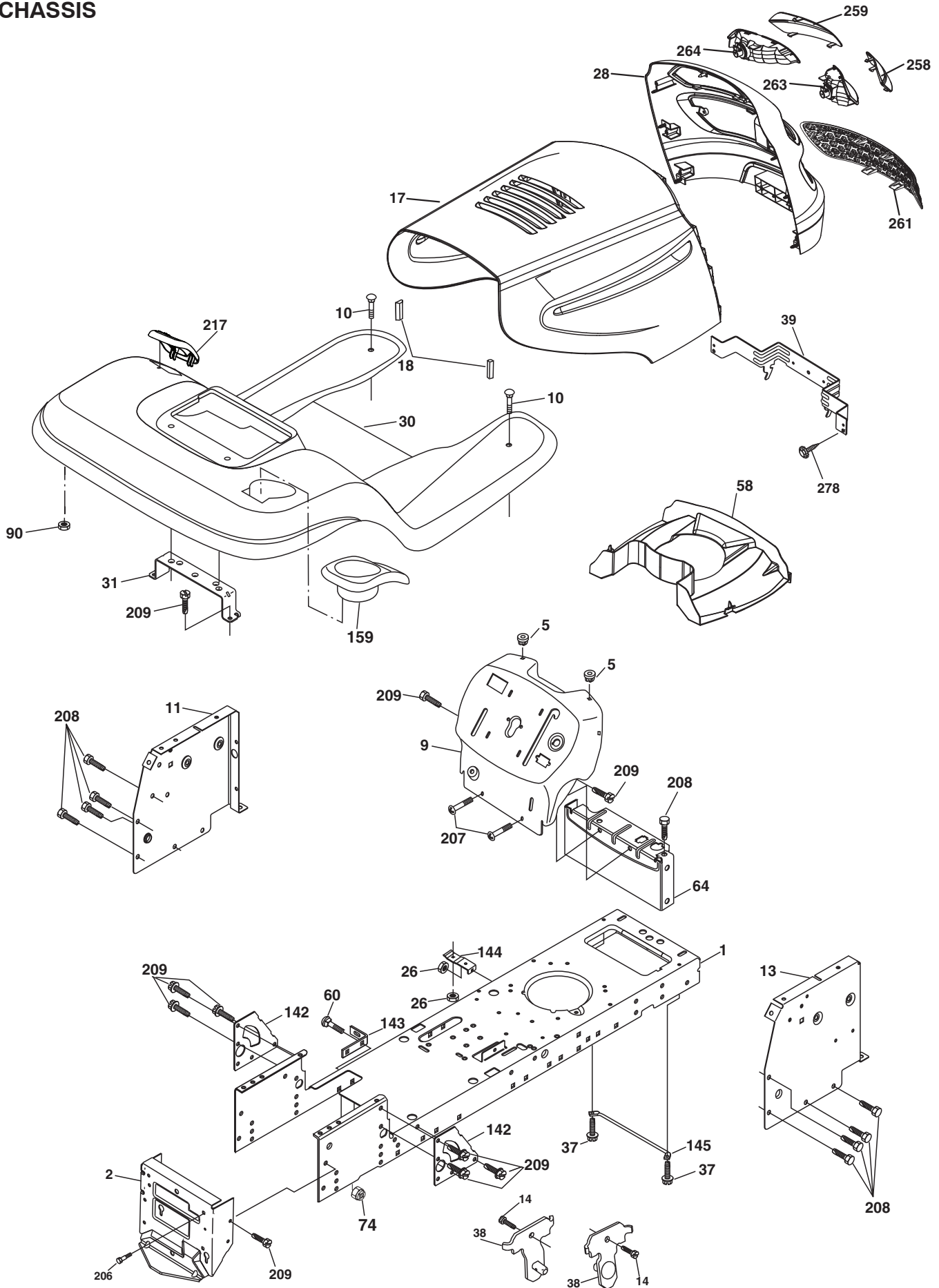

**TRACTOR - - MODEL NUMBER PP21H42 (96011021801), PRODUCT NO. 960 11 02-18
CHASSIS**

KEY PART NO. NO.	DESCRIPTION
1 532 17 46-19	Chassis
2 532 17 65-54	Drawbar
5 532 15 52-72	Bumper Hood/Dash
9 532 40 51-14	Dash P/L
10 872 14 06-08	Bolt Carriage 3/8-16 x 1
11 532 17 49-96	Panel Dash LH
13 532 17 52-55	Panel Dash RH
14 817 49 06-08	Screw Thdrol 3/8-16 x 1/2
17 532 19 45-88	Hood
18 532 18 49-21	Bumper Hood
26 873 80 06-00	Nut Lock Hex w/Ins 3/8-16 unc
28 532 18 38-28	Grille/Lens Asm (Includes Nos. 258, 259, 261, 263, 264)
30 532 19 46-18	Fender
31 532 13 99-76	Bracket Fender
37 817 49 05-08	Screw Thdrol 6/16-18 x 1/2 TYT
38 532 17 57-10	Bracket Asm Pivot Mower Rear
39 532 40 78-07	Bracket Pivot
58 532 18 93-50	Duct Air
60 872 14 06-06	Bolt 3/8-19 unc x 3/4
64 532 15 47-98	Dash Lower STLT
74 873 68 06-00	Nut Crownlock 3/8-16 unc
90 532 12 43-46	Nut 1/4
142 532 17 57-02	Plate Reinforcement STLT
143 532 18 66-89	Bracket Swaybar Chassis
144 532 17 55-82	Bracket Footrest
145 532 40 91-67	Rod Pivot Hood
159 532 19 46-22	Cupholder
206 532 17 01-65	Bolt Shoulder 5/16-18
207 817 67 05-08	Screw Thdrol 5/16-18 x 1/2
208 817 67 06-08	Screw Thdrol 3/8-16 x 1/2
209 817 00 06-12	Screw Hexwsh Thdr 3/8-16 x 3/4
217 532 19 46-19	Console Fuel Window
258 532 18 97-55	Lens Grille Pro RH
259 532 18 97-54	Lens Grille Pro LH
261 532 18 97-53	Insert Grille
263 532 18 38-33	Bezel Grille RH
264 532 18 38-32	Bezel Grille LH
278 532 41 63-58	Screw #10 x .750
-- 532 00 54-79	Plug BTN BIK

NOTE: All component dimensions given in U.S. inches
1 inch = 25.4 mm

TRACTOR - - MODEL NUMBER PP21H42 (96011021801), PRODUCT NO. 960 11 02-18
DRIVE

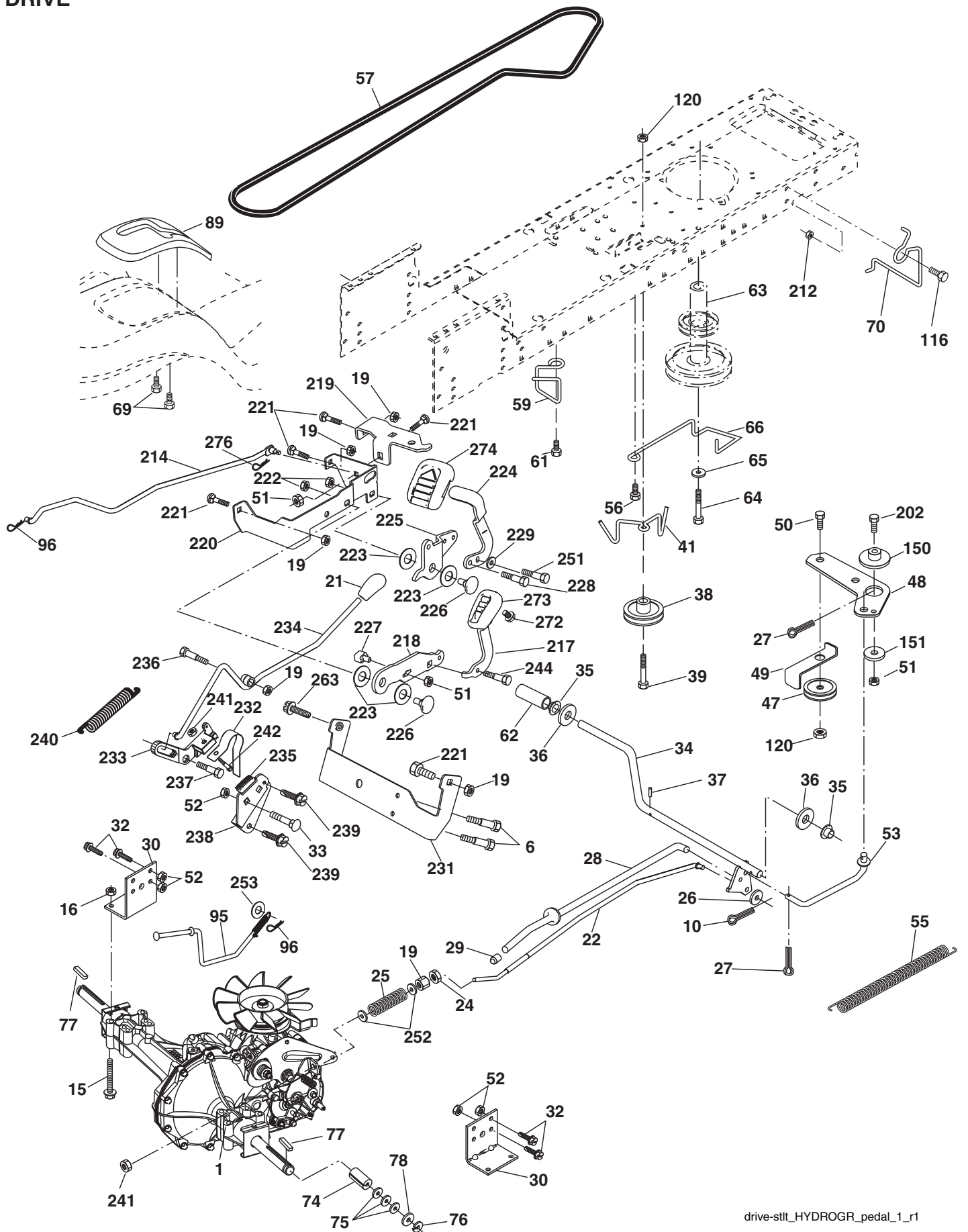

drive-stlt_HYDROGR_pedal_1_r1

TRACTOR - - MODEL NUMBER PP21H42 (96011021801), PRODUCT NO. 960 11 02-18 DRIVE

KEY PART NO. NO.	DESCRIPTION	KEY PART NO. NO.	DESCRIPTION
1	----- Transaxle Hydro gear Model 347-0510 (See Breakdown)	78	532 12 17-48 Washer 25/32 x 1-5/8 x 16 Ga.
6	817 06 05-12 Screw 5/16-18 x 3/4	89	532 19 22-59 Console, Shift
10	876 02 04-16 Pin Cotter	95	532 19 56-31 Rod Bypass
15	874 49 05-44 Bolt Hex Flghd 5/16-18 Gr. 5	96	532 12 47-88 Retainer Spring 1" Zinc/Cad
16	873 80 05-00 Nut Lock Hex w/Ins. 5/16-18 unc	116	872 14 06-08 Bolt 3/8-16 x 1
19	873 80 06-00 Nut Lock Hex w/Wsh 3/8-16 unc	120	873 90 06-00 Nut Lock Flg 3/8-16 unc
21	532 18 65-71 Knob Custom Control Cruise	150	532 17 54-56 Spacer Retainer
22	532 17 58-96 Rod, Brake	151	819 13 32-10 Washer 13/32 x 2 x 10 Ga.
24	873 35 06-00 Nut, Hex Jam 3/8-16 unc	202	872 11 06-14 Bolt RDHD 3/8-16 unc x 1-3/4 Gr. 5
25	532 19 20-36 Spring, Brake Rod	212	532 14 52-12 Nut Hex Flange Lock
26	819 13 13-16 Washer	214	532 17 47-35 Link Transaxle
27	876 02 04-12 Pin Cotter 1/8 x 3/4 CAD.	217	532 17 94-33 Pedal Reverse
28	532 17 57-65 Rod, Parking Brake	218	532 17 47-13 Arm Control Pedal Reverse
29	532 07 16-73 Cap Brake Parking	219	532 17 48-39 Bracket Frest Pdl Ctrl. Hyd
30	532 16 95-92 Bracket, Transaxle	220	532 17 47-11 Bracket Mtg. Pedal Control
32	874 76 05-12 Bolt Hex Hd 5/16-18 unc x 3/4	221	872 14 06-06 Bolt Rdhd Sqnk 3/8-16 unc x 3/4
33	872 14 05-06 Bolt Rdhd Sqnk 5/16-18 unc x 3/4	222	873 68 07-00 Nut Crownlock 7/16-14 unc
34	532 17 55-78 Shaft, Foot Pedal	223	532 17 48-40 Washer Nylon 11/16 ID x .060
35	532 12 01-83 Bearing, Nylon	224	532 17 47-36 Pedal Forward
36	819 21 16-16 Washer	225	532 17 47-12 Arm Control Pedal Forward
37	532 12 49-63 Pin, Roll	226	532 17 49-02 Bolt Pivot Spacer
38	532 17 91-14 Pulley, Composite, Flat	227	532 17 47-10 Cam Reverse Pedal LT
39	872 11 06-22 Bolt Rdhd 3/8-16 unc x 2-3/4 Gr. 5	228	532 17 90-32 Bolt Shoulder 5/16-18
41	532 17 55-56 Keeper, Belt Idler Flat	229	532 17 64-51 Washer Serrated 5/16 x .75
47	532 12 77-83 Pulley, Idler, V-Groove	231	532 40 25-50 Strap Torque
48	532 15 44-07 Bellcrank Clutch Grnd Drw Stl	232	532 17 55-70 Actuator Cruise Disengage
49	532 12 32-05 Retainer, Belt	233	532 17 48-56 Pawl Control Cruise
50	872 11 06-12 Bolt Carr Sh 3/8-16 x 1-1/2 Gr. 5	234	532 17 48-58 Lever Control Cruise
51	873 68 06-00 Nut Crownlock 3/8-16 unc	235	532 17 48-57 Sector Control Cruise
52	873 68 05-00 Nut, Crownlock 5/16-18 unc	236	532 12 89-03 Bolt Shoulder 3/8-16 unc 1/44
53	532 19 96-52 Link, Clutch	237	532 17 01-65 Bolt Shoulder 5/16-18
55	532 10 57-09 Spring, Return, Clutch	238	532 17 58-07 Arm Mtg. Cruise Sector
56	817 06 06-20 Screw 3/8-16 x 1-1/4	239	817 49 05-08 Screw Thdrol 5/16 x 1/2
57	532 14 02-94 V-Belt, Ground Drive	240	532 17 56-10 Spring Return Cruise Control
59	532 16 96-91 Keeper, Center Span	241	873 93 04-00 Nut Centerlock 1/4-20 unc
61	817 12 06-14 Screw 3/8-16 x .875	242	874 78 04-12 Bolt Fin Hex 1/4-20 x .75
62	532 12 48-72 Cover, Pedal	244	817 49 05-10 Screw 5/16-18 x 5/8
63	532 17 54-10 Pulley, Engine	251	817 06 05-16 Screw 5/16-18
64	532 17 39-37 Bolt 7/16-20 x 4 x Gr. 5	252	819 13 16-16 Washer 13/32 x 1 x 16 Ga.
65	810 04 07-00 Washer	253	532 17 94-22 Washer .3125 x .615 x 16 Gr.
66	532 15 47-78 Keeper Belt Engine	263	817 00 06-12 Screw 3/8-16 x .75
69	532 14 24-32 Screw Hex Wsh Hi-Lo 1/4-1/2 unc	272	817 67 05-08 Screw, 5/16-18 x 1/2 TT
70	532 13 46-83 Guide Mower Drive RH	273	532 17 96-10 Pad, Reverse Pedal
74	532 13 70-57 Spacer, Axle	274	532 17 56-46 Cover Pedal Forward
75	532 12 17-49 Washer 25/32 x 1-1/4 x 16 Ga.	276	532 17 80-62 Clip Retainer .0375
76	812 00 00-01 E-Ring		
77	532 12 35-83 Key, Square		

NOTE: All component dimensions given in U.S. inches
1 inch = 25.4 mm

**TRACTOR - - MODEL NUMBER PP21H42 (96011021801), PRODUCT NO. 960 11 02-18
ENGINE**

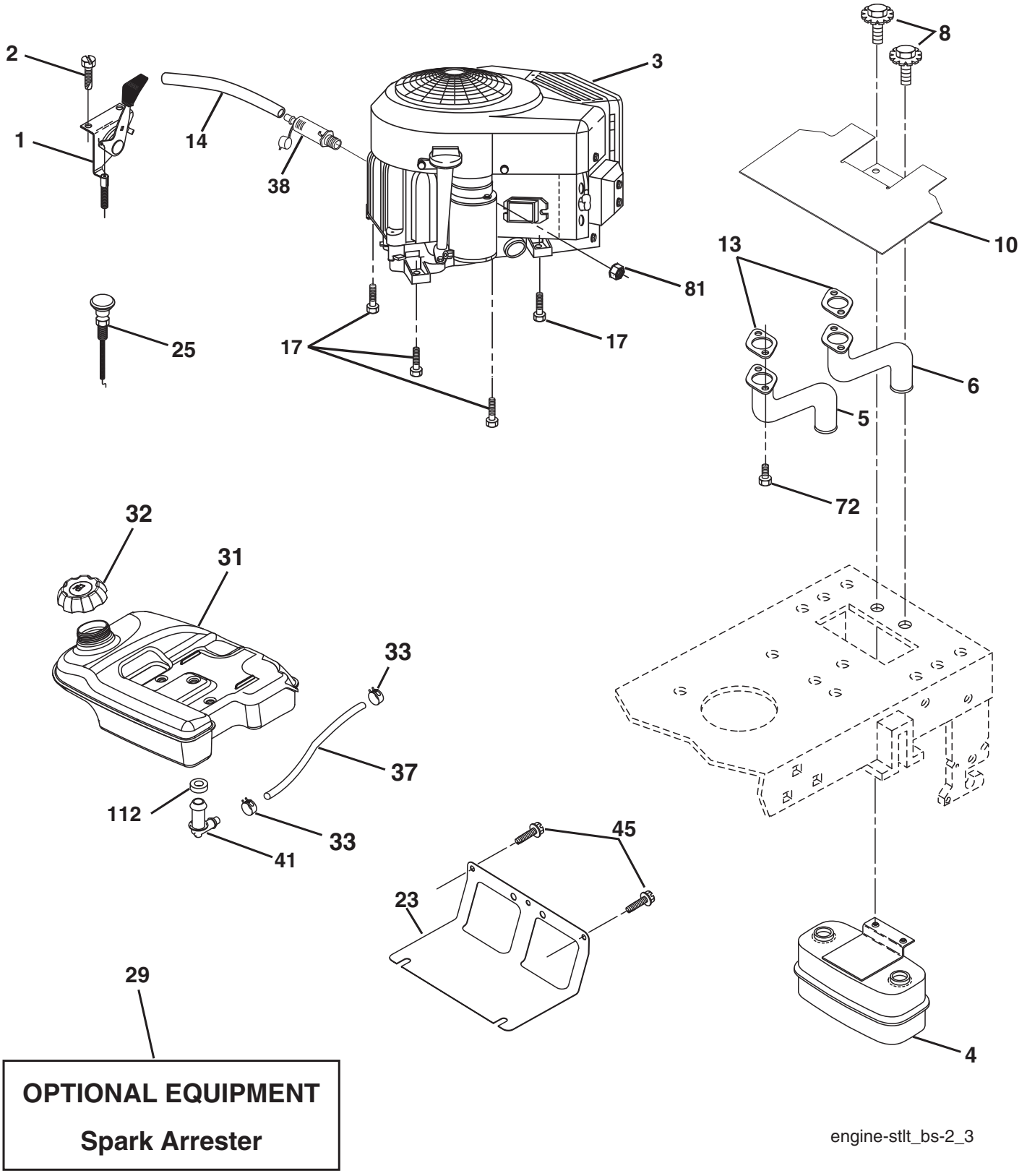

engine-stlt_bs-2_3

TRACTOR - - MODEL NUMBER PP21H42 (96011021801), PRODUCT NO. 960 11 02-18 ENGINE

KEY PART NO.	NO.	DESCRIPTION
1	532 17 05-51	Control, Throttle
2	817 72 04-08	Screw Hex Thd Cut 1/4-20 x 1/2
3	-----	Engine Briggs Model 441677 (Order Parts from Engine Mfg.)
4	532 14 97-23	Muffler
5	532 15 99-55	Exhaust Tube LH
6	532 16 05-89	Exhaust Tube RH
8	532 17 18-77	Bolt 5/16-18 x 3/4 w/Sems
10	532 14 66-29	Shield Browning
13	532 16 53-91	Muffler Gasket
14	532 14 84-56	Tube Oil Drain
17	817 06 06-24	Screw 3/8-16 x 1-1/2
23	532 16 98-37	Shield, Browning/Debris Guard
25	532 19 17-17	Control Choke
29	532 13 71-80	Arrester, Spark
31	532 17 90-22	Tank, Fuel
32	532 18 29-02	Cap, Fuel
33	532 12 34-87	Clamp, Hose Blk
37	532 14 21-58	Line, Fuel
38	532 18 16-54	Plug Drain Oil Easy
41	532 13 92-77	Stem Tank Fuel
45	817 00 06-12	Screw Hex Wsh Thdrol 3/8-16 x 3/4
72	532 18 39-06	Screw Socket Head 5/16-18 x 1
81	873 51 04-00	Nut Keps Hex 1/4-20 unc
112	532 12 49-52	Bushing

NOTE: All component dimensions given in U.S. inches
1 inch = 25.4 mm

For engine service and replacement parts, call the toll free number for your engine manufacturer listed below:

Briggs & Stratton 1-800-233-3723

Engine Power Rating Information

The gross power rating for individual gas engine models is labeled in accordance with SAE (Society of Automotive Engineers) code J11940 (Small Engine Power & Torque Rating Procedure), and rating performance has been obtained and corrected in accordance with SAE J1995 (Revision 2002-5). Actual gross engine power will be lower and is affected by, among other things, ambient operating conditions and engine-to-engine variability. Given both the wide array of products on which engines are placed and the variety of environmental issues applicable to operating the equipment, the gas engine will not develop the rated gross power when used in a given piece of power equipment (actual "on-site" or net horsepower). This difference is due to a variety of factors including, but not limited to, accessories (air cleaner, exhaust, charging, cooling, carburetor, fuel pump, etc.), application limitations, ambient operating conditions (temperature, humidity, altitude), and engine-to-engine variability. Due to manufacturing and capacity limitations, Briggs & Stratton may substitute an engine of higher rated power for this Series engine.

TRACTOR - - MODEL NUMBER PP21H42 (96011021801), PRODUCT NO. 960 11 02-18
SEAT ASSEMBLY

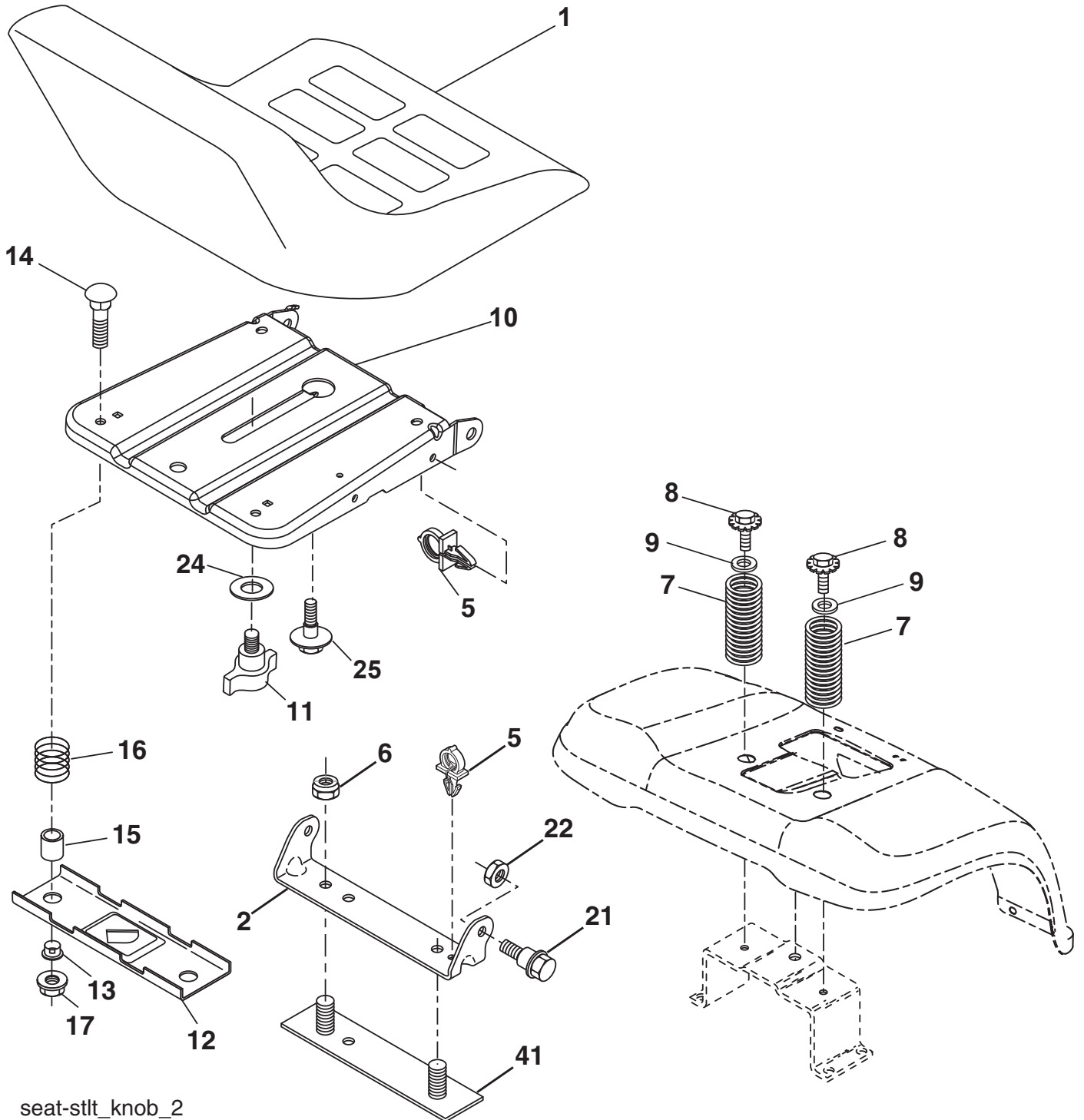

seat-stlt_knob_2

**TRACTOR - - MODEL NUMBER PP21H42 (96011021801), PRODUCT NO. 960 11 02-18
SEAT ASSEMBLY**

KEY PART NO. NO.	DESCRIPTION
1 532 18 87-12	Seat
2 532 14 05-51	Bracket Pivot Seat 8 720
5 532 14 50-06	Clip Push-In
6 873 80 06-00	Nut Hex w/Ins. 3/8-16 unc
7 532 12 41-81	Spring Seat Cprsn 2 250 Blk Zi
8 817 00 06-16	Screw 3/8-16 x 1.5 Smgml
9 819 1316-14	Washer 13/32 x 1 x 14 Ga.
10 532 19 55-30	Pan Seat
11 532 16 63-69	Knob Seat
12 532 17 46-48	Bracket Mounting Switch
13 532 12 12-48	Bushing Snap Blk Nyl 50 Id
14 872 05 04-12	Bolt Rdhd Sqnk 1/4-20 x 1-1/2
15 532 13 43-00	Spacer Split 28 x 88
16 532 12 12-50	Spring Cprsn
17 532 12 39-76	Nut Lock 1/4 Lge Flg Gr. 5 Zinc
21 532 17 18-52	Bolt Shoulder 5/16-18 unc
22 873 80 05-00	Nut Hex Lock w/Ins 5/16-18
24 819 17 19-12	Washer 17/32 x 1-3/16 x 12 Ga.
25 532 12 70-18	Bolt Shoulder 5/16-18 x 62
41 532 14 06-75	Strap Asm Fender

NOTE: All component dimensions given in U.S. inches
1 inch = 25.4 mm

TRACTOR - - MODEL NUMBER PP21H42 (96011021801), PRODUCT NO. 960 11 02-18
STEERING ASSEMBLY

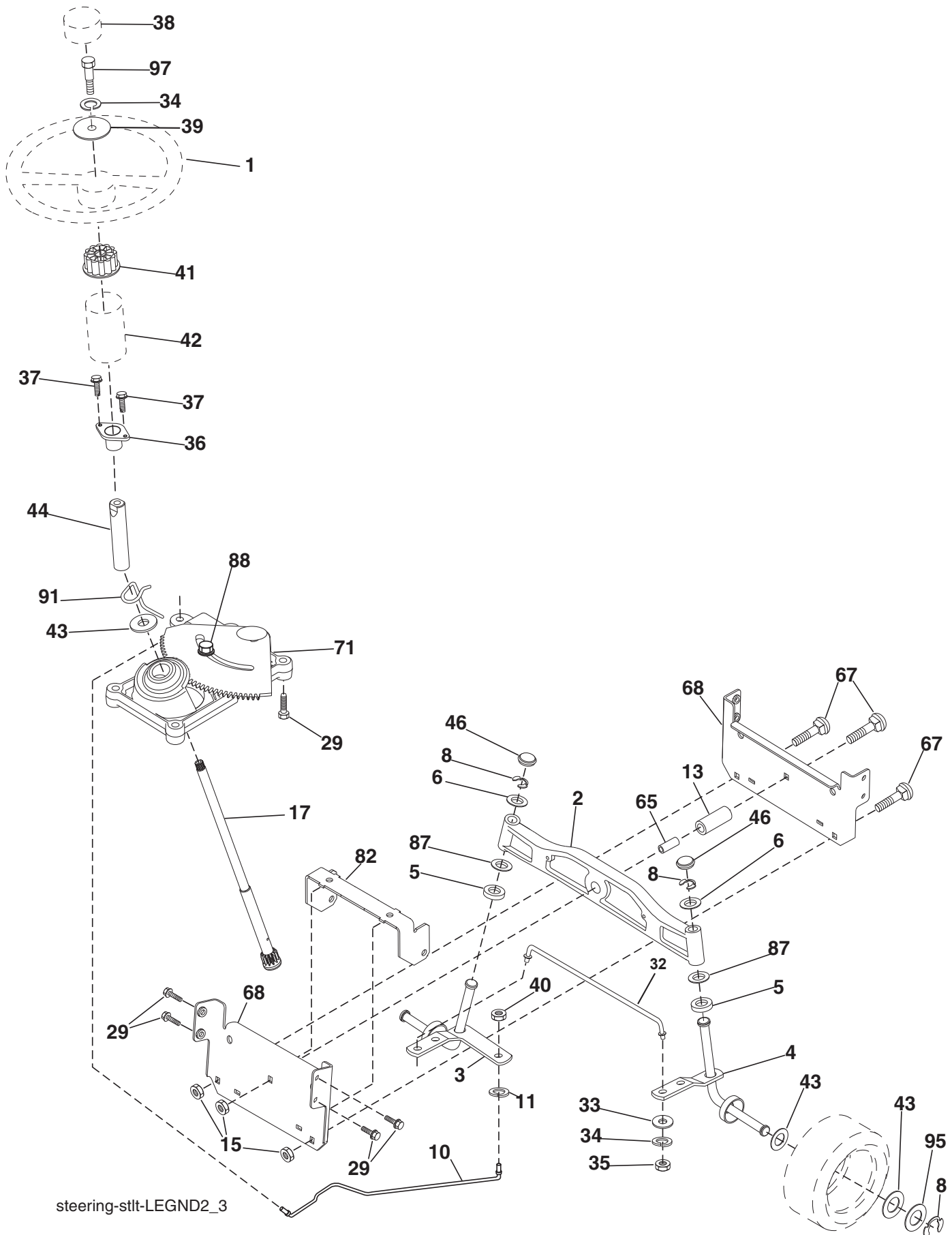

steering-stlt-LEGND2_3

**TRACTOR - - MODEL NUMBER PP21H42 (96011021801), PRODUCT NO. 960 11 02-18
STEERING ASSEMBLY**

KEY PART NO. NO.	DESCRIPTION
1 532 19 45-95	Wheel Steering
2 532 18 47-06	Axle Asm
3 532 16 98-40	Spindle Asm LH
4 532 16 98-39	Spindle Asm RH
5 532 12 49-31	Bearing Race Thrust Harden
6 532 12 17-48	Washer 25/32 x 1-5/8 x 16 Ga.
8 812 00 00-29	Ring Clip #T5304-75
10 532 17 51-21	Link Drag
11 810 04 06-00	Washer Lock Hvy Hlcl Spr 3/8
13 532 13 65-18	Spacer Brg Axle Front
15 532 14 52-12	Nut Hex Flange Lock
17 532 19 07-53	Shaft Asm Steering
26 532 12 68-47	Bushing Link Drag
28 819 13 14-16	Washer 13/32 x 7/8 x 16 Ga.
29 817 00 06-12	Screw 3/8-16 x .75
30 876 02 04-12	Pin Cotter 1/8 x 3/4
32 532 19 27-57	Rod Tie
34 810 04 05-00	Washer Lock Hvy Hlcl Spr 5/16
36 532 15 50-99	Bushing Strg
37 532 15 29-27	Screw
38 532 19 46-03	Insert Cap Strg Wh
39 819 11 38-12	Washer 11/32 ID x 2-3/8 OD 12 Ga.
40 873 54 06-00	Crownlock Nut
41 532 18 67-37	Adaptor Wheel Strg
42 532 16 96-33	Boot Steering Dash
43 532 12 17-49	Washer 25/32 x 1 1/4 x 16 Ga.
44 532 19 07-52	Extension Steering Shaft
46 532 12 12-32	Cap Spindle Fr Top Blk
65 532 41 47-36	Spacer Brace Axle
67 872 11 06-18	Bolt RDHD SQNK 3/8-16 x 2 1/4
71 532 17 51-46	Steering Asm
68 532 16 98-27	Axle, Brace
82 532 19 99-78	Bracket Susp Chassis Front
87 532 17 39-66	Washer Flat .781 x 1 1/2 x .14
88 532 17 51-18	Bolt Shoulder 7/16-20 unc
91 532 17 55-53	Clip Steering
95 532 18 89-67	Washer Harden .739 x 1.637 x .060
97 874 78 05-64	Bolt 5/16-18 unc x 4" L Gr. 5

NOTE: All component dimensions given in U.S. inches
1 inch = 25.4 mm

TRACTOR - - MODEL NUMBER PP21H42 (96011021801), PRODUCT NO. 960 11 02-18
MOWER DECK

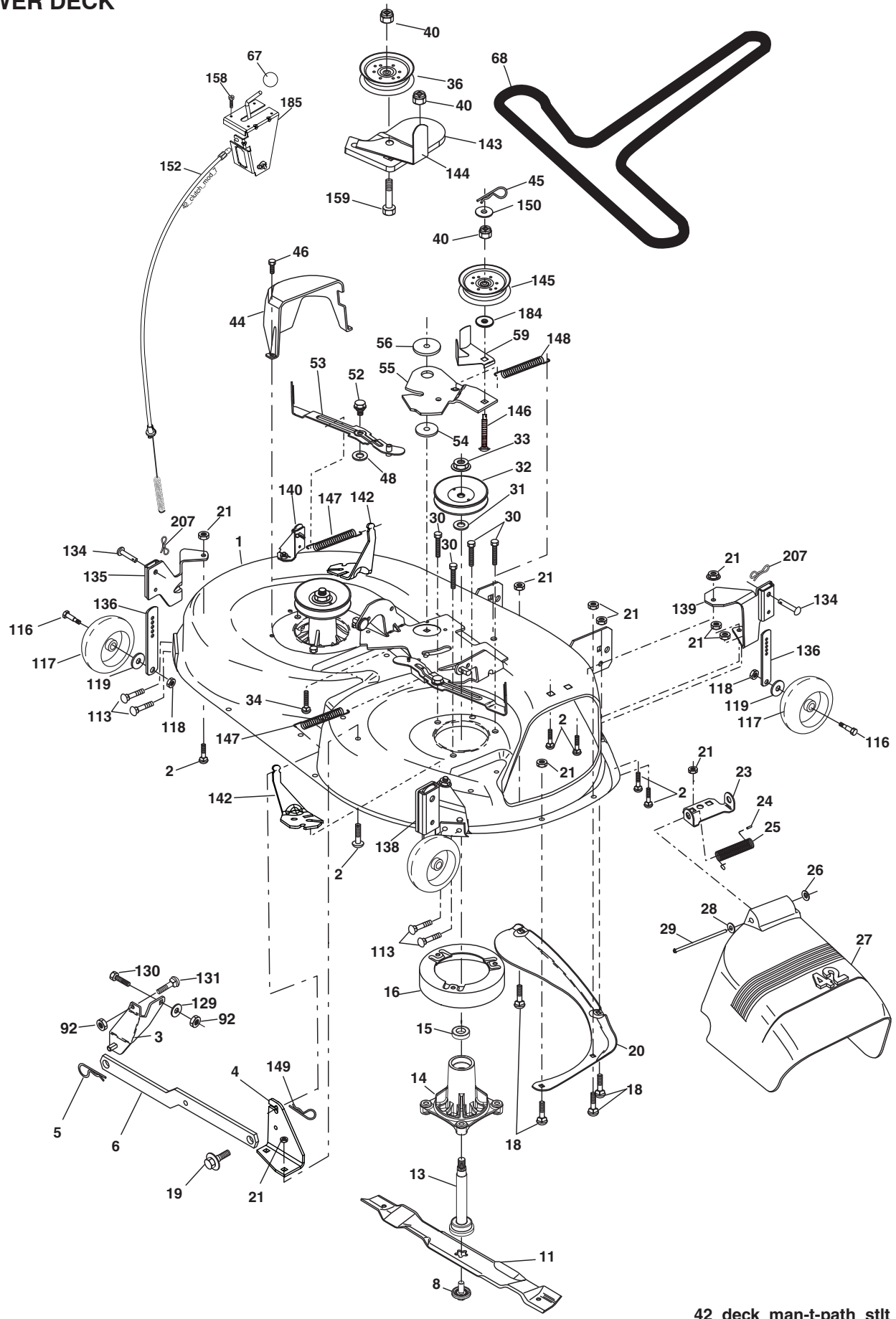

42_deck_man-t-path_stlt_13

TRACTOR - - MODEL NUMBER PP21H42 (96011021801), PRODUCT NO. 960 11 02-18 MOWER DECK

KEY PART NO. NO.	DESCRIPTION	KEY PART NO. NO.	DESCRIPTION
1	532 18 64-26 Mower Deck Assembly, 42"	68	532 14 49-59 V-Belt, 42" Mower
2	872 14 05-06 Bolt	92	873 80 06-00 Nut 3/8-16
3	532 13 80-17 Bracket Asm Fr. Sway Bar 3/42	113	817 00 05-10 Screw 5/16-18
4	532 16 54-60 Bracket Asm Deck 42" Sway Bar	116	532 19 34-06 Bolt, Shoulder
5	532 12 46-70 Retainer Spring	117	532 17 48-73 Wheel, Gauge
6	532 17 80-24 Bar Sway Deck	118	873 93 06-00 Nut Centerlock 3/8-16
8	532 19 30-03 Bolt/Washer Asm. 7/16-20 unf (The following blades are available)	119	819 12 14-14 Washer 3/8 x 7/8 x 14 Ga.
11	532 13 89-71 Blade Mower 42" Hi-Lift (for bagging and discharging)	129	819 13 13-12 Washer 13/32 x 13/16 x 12 Ga.
13	532 19 28-72 Shaft Assembly, Mandrel	130	874 78 06-16 Bolt 3/8-16 x Gr.5
14	532 18 72-81 Housing, Mandrel	131	872 14 06-08 Bolt 3/8-16 x 1
15	532 11 04-85 Bearing, Ball, Mandrel	134	532 15 69-41 Pin Head Rivet
16	532 17 44-93 Stripper, Mandrel Deck	135	532 15 97-65 Bracket Asm Wheel Gauge LH Rear
18	872 14 05-05 Bolt, Carriage 5/16-18 x 5/8	136	532 15 59-86 Bar Adjusting Gauge Wheel
19	532 13 28-27 Bolt, Shoulder	138	532 15 97-63 Bracket Asm Wheel Gauge RH Rear
20	532 15 97-70 Baffle, Vortex	139	532 15 97-67 Bracket Asm Wheel Gauge RH Front
21	873 68 05-00 Nut	140	532 15 97-68 Bracket Asm Wheel Gauge LH Front
23	532 17 75-63 Bracket, Deflector Mower 42"	142	532 19 57-84 Arm Spring Brake Mower
24	532 10 53-04 Cap, Sleeve 80 x 112 Blk Mower	143	532 15 71-09 Bracket Arm Idler 42"
25	532 12 37-13 Spring, Torsion, Deflector 2 52	144	532 17 34-41 Keeper Belt 42" Clutch Cable
26	532 11 04-52 Nut, Push Phos & Oil	145	532 17 34-37 Pulley Idler Flat
27	532 17 18-59 Shield, Deflector 42" Blk	146	532 17 34-43 Bolt Carriage Idler
28	819 11 10-16 Washer 11/32 x 5/8 x 16 Ga.	147	532 13 13-35 Spring Extension
29	532 13 14-91 Rod, Hinge 42" 6 75 W/G	148	532 16 90-22 Spring Return Idler
30	532 17 39-84 Screw Thdrol	149	532 16 58-98 Retainer Spring Yellow
31	532 18 76-90 Washer, Spacer Mower Vented	150	819 09 12-10 Washer 9/32 x 3/4 x 10 Ga.
32	532 15 35-35 Pulley, Mandrel	152	532 16 96-76 Clutch Cable 42"
33	532 40 02-34 Nut, Toplock	158	817 72 04-08 Screw Hex Thd Cut 1/4-20 x 1/2
34	872 11 06-12 Bolt Carr SH 3/8-16 x 1-1/2 Gr. 5	159	872 14 06-14 Bolt Rdhd Sqn 3/8-16 unc x 1-3/4
36	532 17 34-38 Pulley, Idler, Flat	184	819 13 14-10 Washer 13/32 x 7/8 x 10 Ga.
40	873 90 06-00 Nut Lock 3/8-16	183	532 19 42-08 Pin Cotter 5/16 Bowtie Lock
44	532 14 00-88 Guard, Mandrel, LH	185	532 18 82-34 Head Asm Cable Clutch
45	532 12 47-88 Retainer	207	532 19 42-08 Pin Cotter 5/16 Bow Tie Lock
46	532 13 77-29 Screw, Thdrol 1/4-20 x 5/8 T	--	532 19 28-70 Mandrel Assembly (Includes Housing, shaft assembly, and bearing only - pulley/nut/washer and blade bolt/washers not included)
48	532 13 39-44 Washer, Hardened	--	532 18 45-63 Replacement Mower, Complete (Std. deck-Order seperately gauge wheel components Key Nos. 116-119)
52	532 13 98-88 Bolt, Shoulder 5/16-18 unc		
53	532 18 49-07 Arm Assembly, Pad, Brake		
54	532 17 85-15 Washer, Hardened		
55	532 15 50-46 Arm, Idler		
56	532 12 20-52 Spacer, Retainer		
59	532 14 10-43 Guard TUV Idler		
67	532 17 15-98 Knob		

NOTE: All component dimensions given in U.S. inches
1 inch = 25.4 mm

**TRACTOR - - MODEL NUMBER PP21H42 (96011021801), PRODUCT NO. 960 11 02-18
MOWER LIFT**

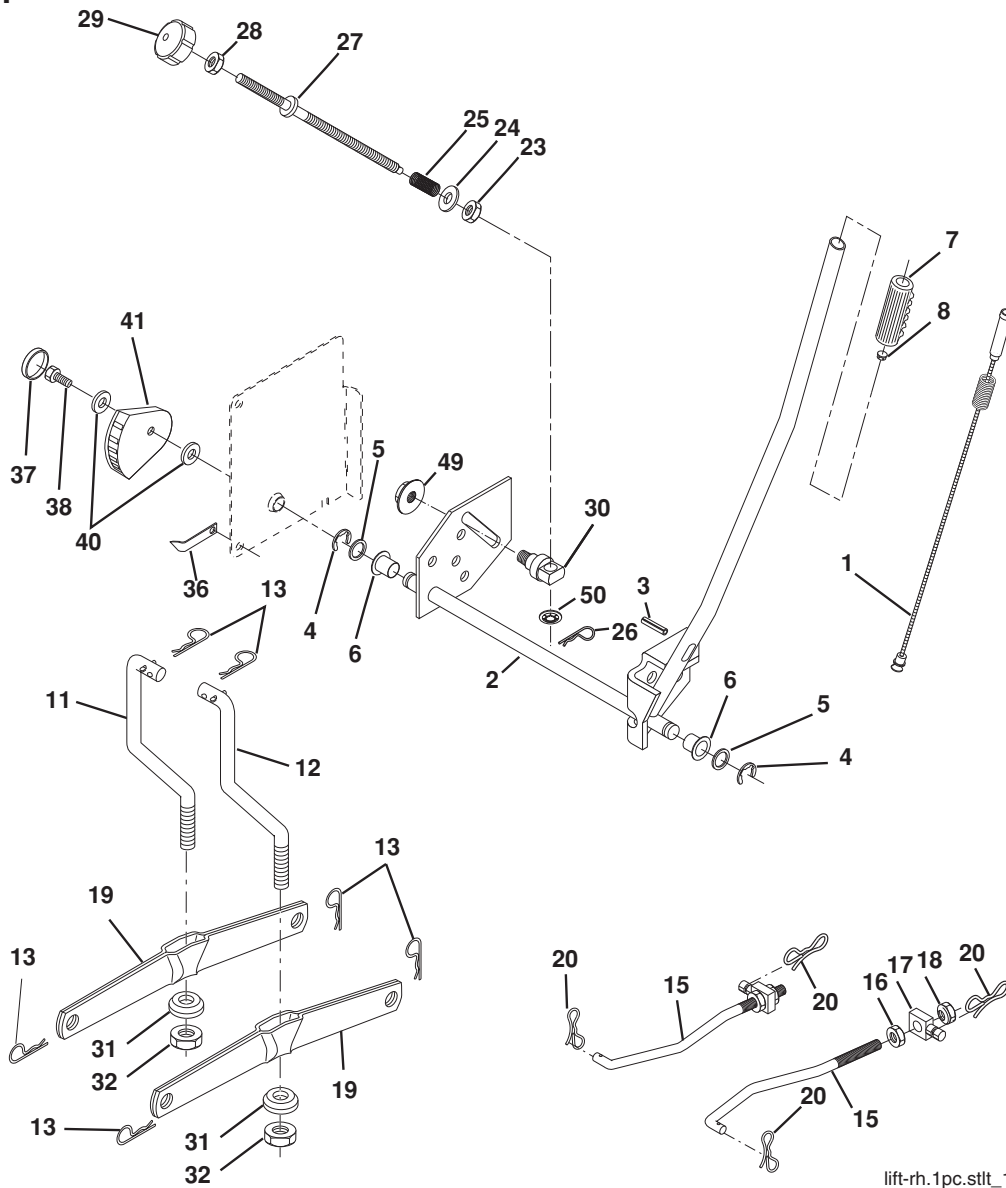

lift-rh.1pc.stlt_1

**KEY PART
NO. NO.**

DESCRIPTION

1	532 19 84-17	Wire Asm Inner/Sprg w/plunger
2	532 19 80-70	Shaft Asm Lift RH w/Inf
3	532 18 88-22	Pin Groove 5/16 Dia x 1.875
4	812 00 00-02	E Ring #5133-62
5	819 21 16-21	Washer 21/32 x 1 x 21 Ga.
6	532 12 01-83	Bearing Nylon Blk 629 Id
7	532 12 56 31	Grip Handle
8	532 17 07-70	Button Plunger
11	532 13 98-65	Link Lift LH Fixed Length
12	532 13 98-66	Link Lift RH Fixed Length
13	532 12 46-70	Retainer Spring
15	532 17 32-88	Link Front
16	873 35 08-00	Nut Jam Hex 1/2-13 unc
17	532 17 56-89	Trunnion
18	873 80 08-00	Nut Lock w/Wsh 1/2-13 unc
19	532 13 98-68	Arm Suspension Rear
20	532 19 42-09	Pin Cotter 7/16 Bow Tie Lock
23	532 11 08-07	Nut Special
24	819 13 10-16	Washer 13/32 x 5/8 x 16 Ga.

**KEY PART
NO. NO.**

DESCRIPTION

25	532 12 48-74	Spring
26	532 16 94-84	Retainer Clip
27	532 12 69-71	Rod Adj Lift
28	873 35 06-00	Nut Hex Jam 3/8-16 unc
29	532 13 80-57	Knob
30	532 15 02-33	Trunnion
31	532 16 98-65	Bearing Pvt Lift
32	873 54 06-00	Nut Crownlock 3/8 - 24
36	532 15 50-97	Pointer Height Ind.
37	532 12 39-35	Plug Hole
38	817 06 05-16	Screw 5/16-18 x 1
40	819 11 24-10	Washer 11/32 x 1-1/2 10 Ga.
41	532 15 50-98	Scale Height Ind.
49	532 14 52-12	Nut Hex Flange Lock
50	532 11 04-52	Nut Push

NOTE: All component dimensions given in U.S. inches
1 inch = 25.4 mm

TRACTOR - - MODEL NUMBER PP21H42 (96011021801), PRODUCT NO. 960 11 02-18 DECALS

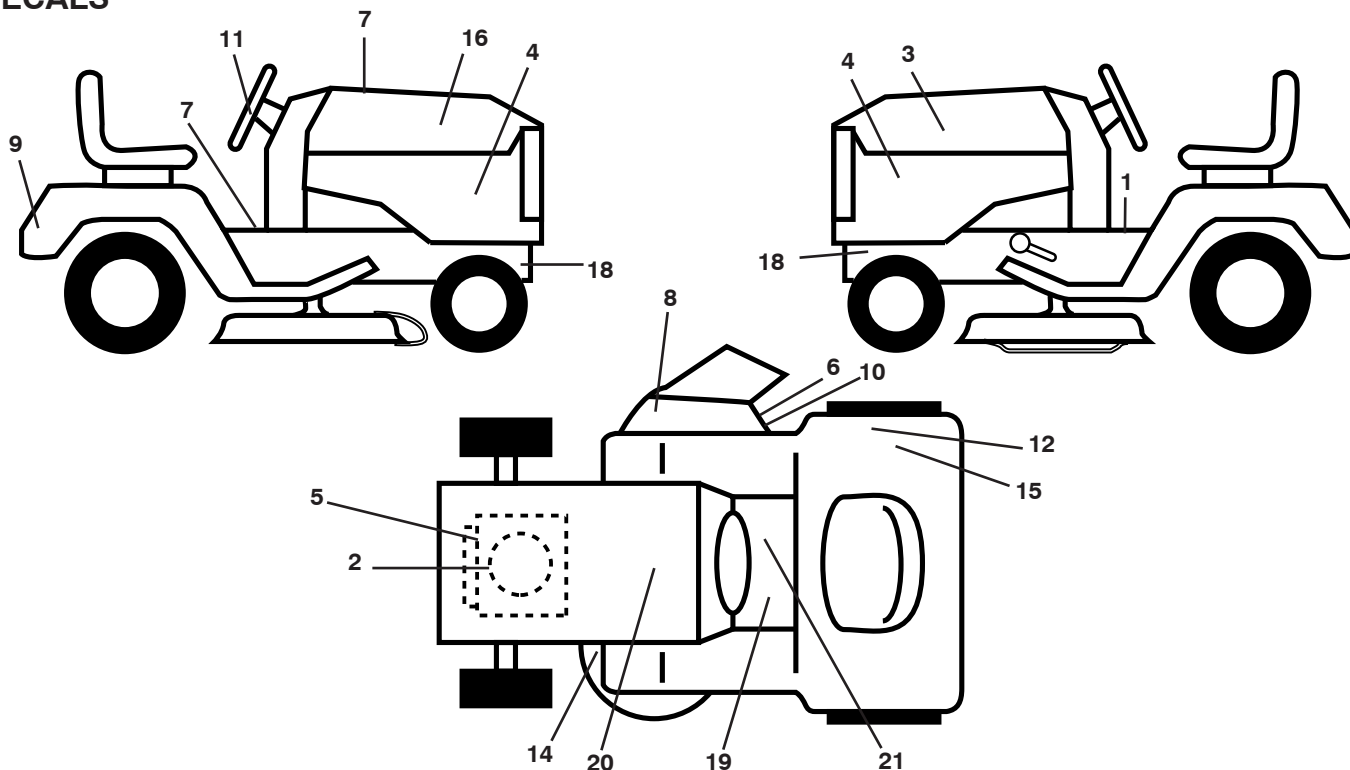

KEY PART NO. NO.

KEY PART NO.	NO.	DESCRIPTION
1	53217 83-02	Decal Operation
2	532 18 95-26	Decal Engine RP
3	532 18 61-64	Decal Hood LH
4	532 19 55-12	Decal Side Panel Logo
5	532 19 68-41	Decal Warning Eng Lym.
6	532 18 21-66	Decal Cutfinger CE
7	532 40 03-89	Decal Warning Sym CE
9	532 17 27-40	Decal Fender Logo
10	532 19 63-57	Deflector Cutfinger Sym
11	532 17 27-43	Decal Ins Strg Whl
12	532 12 44-33	Decal DBA
14	532 16 03-96	Decal Schematic
15	532 16 88-69	Decal Tick Mark

KEY PART NO. NO.

KEY PART NO.	NO.	DESCRIPTION
16	532 18 61-63	Decal Hood Rh
18	532 15 97-36	Decal Hot Muffler
19	532 15 97-37	Decal Brake/Clutch symb
20	532 14 50-05	Decal Bat Dan/Psn
21	532 14 08-37	Decal Saddle Brake Parking
--	532 19 17-87	Pad Footrest LH
--	532 19 17-86	Pad Footrest RH
--	532 13 83-11	Decal Handle Lft Height Adjust
--	532 16 25-98	Decal Load Limit
--	532 16 69-60	Decal Bypass
--	532 40 36-87	Manual Operator's
--	532 41 91-64	Manual Parts

WHEELS AND TIRES

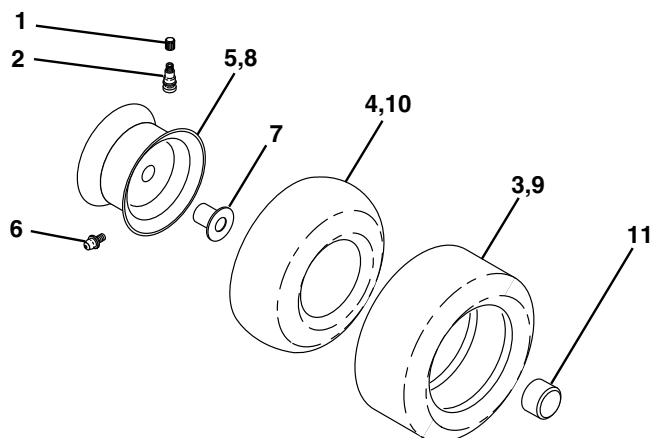

KEY PART NO. NO.

KEY PART NO.	NO.	DESCRIPTION
1	532 05 91-92	Cap Valve Tire
2	532 06 51-39	Stem Valve
3	532 10 62-22	Tire F T 15 x 6 0 - 6 Service
4	532 05 99-04	Tube Front (Service Item Only)
5	532 12 51-21	Rim Asm 6" Front Service
6	532 12 49-57	Fitting Grease (Front Wheel Only)
7	532 12 49-59	Bearing Flange (Front Wheel nly)
8	532 12 51-22	Rim Asm 8" Rear Service
9	532 12 20-82	Tire R T 20 x 10-8 Service
10	532 00 71-52	Tube Rear (Service Item Only)
11	532 19 32-68	Cap Axle Blk 1 50 x 1 00
--	532 14 43-34	Sealant, Tire (10 oz. Tube)

NOTE: All component dimensions given in U.S. inches
1 inch = 25.4 mm

Poulan PRO