

Comfort 500 Art. 433

Comfort 800 Art. 435

D Montageanleitung
Streuwagen

GB Assembly Instructions
Spreader

F Instructions de montage
Epandeur

NL Montage-instructie
Strooiwagen

S Monteringsanvisning
Universalspridare

DK Monteringsvejledning
Universalspreder

I Istruzioni di montaggio
Spandiconcime

E Instrucciones de montaje
Carro esparcidor

P Instruções de montagem
Carro semeador

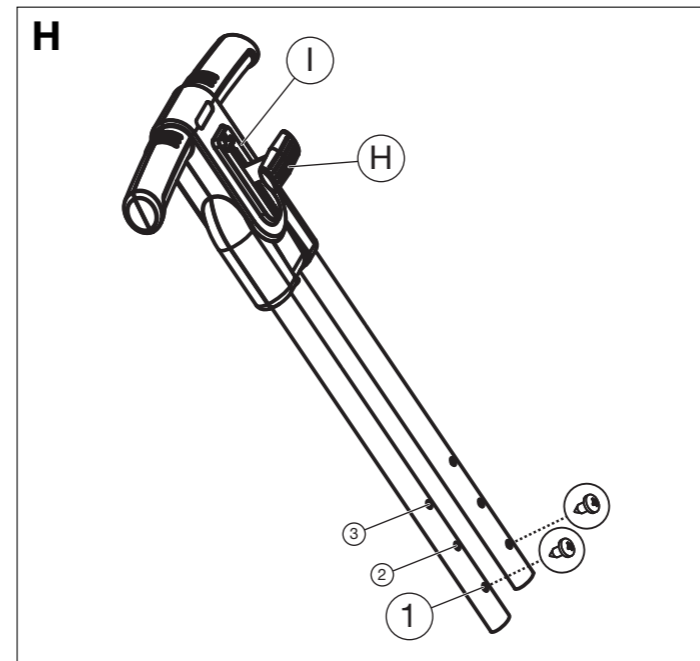
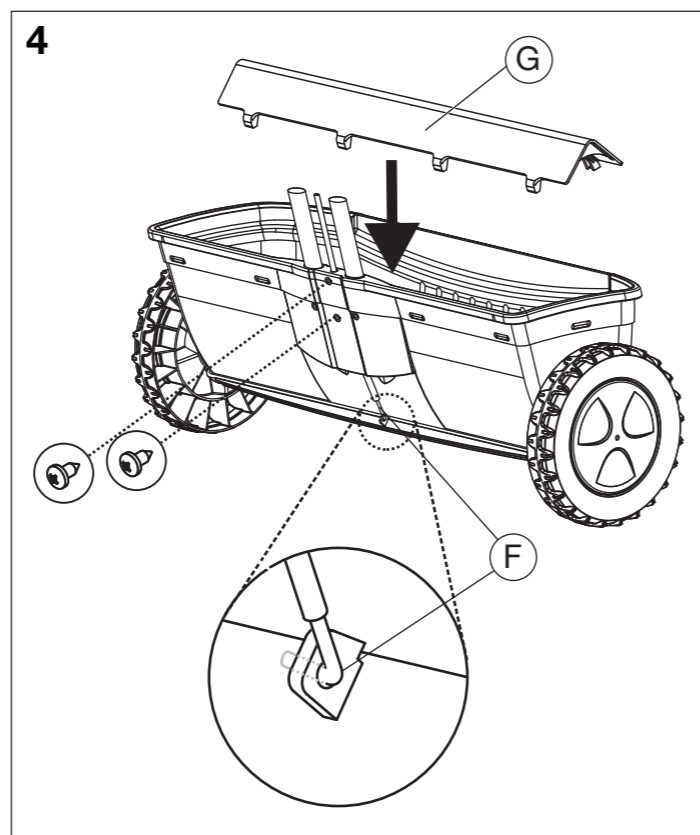
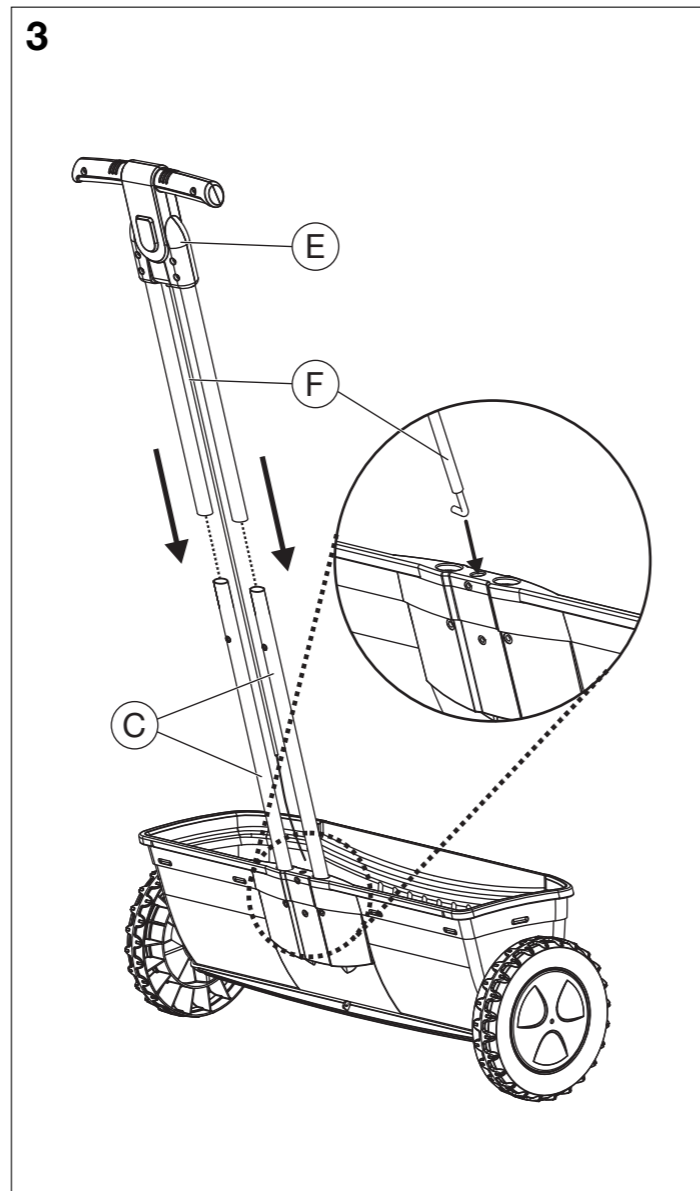
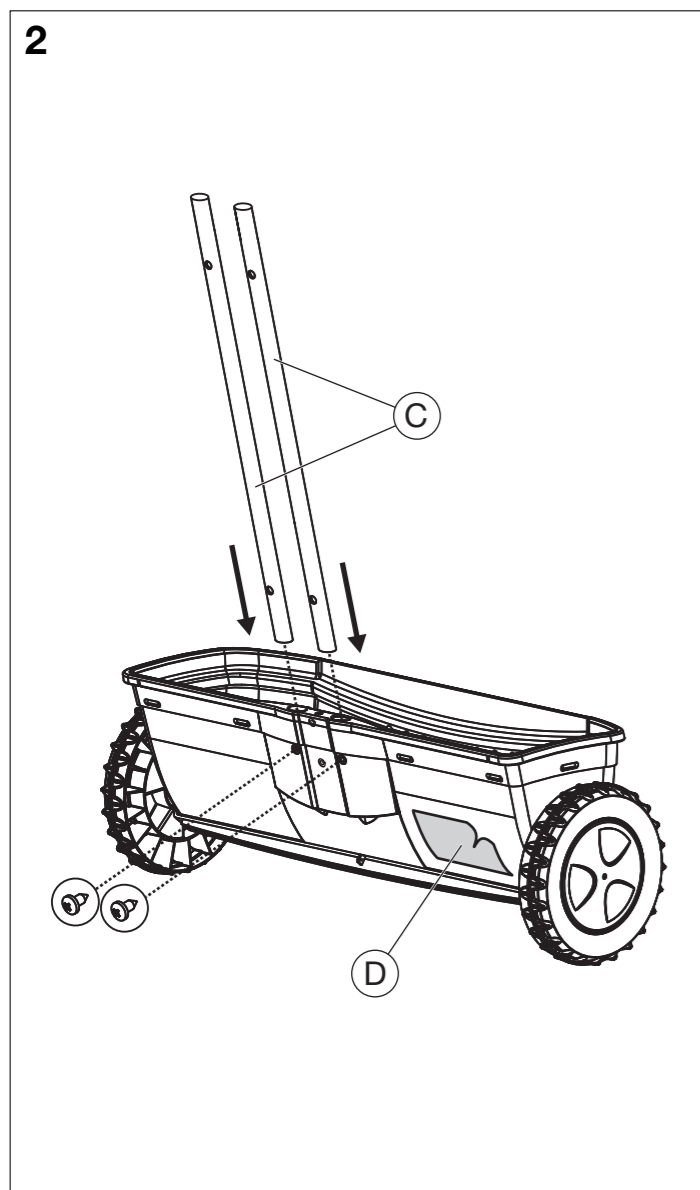
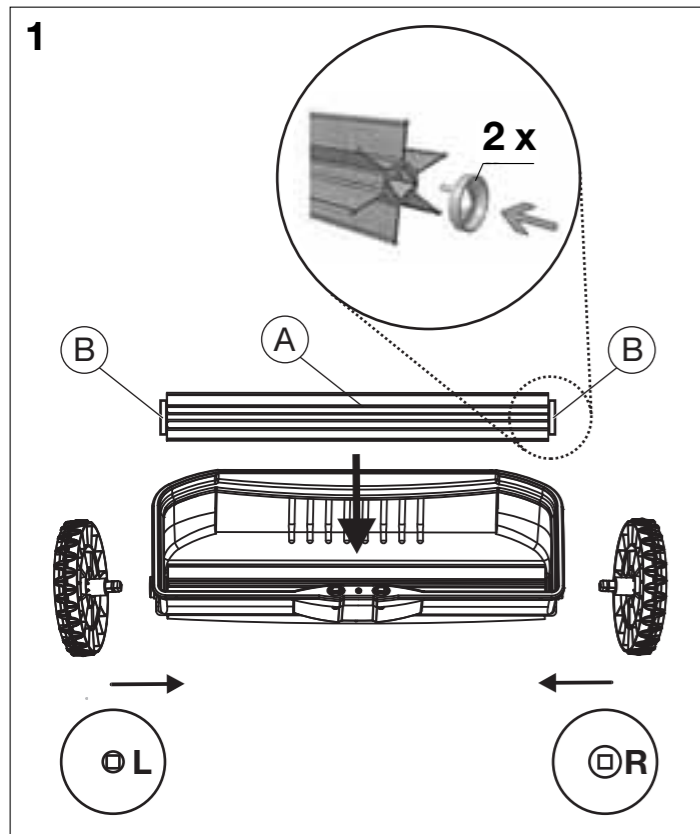

D

Montage:

1. Walze ④ montieren. Dabei darauf achten, dass die beiden Manschetten ⑤ auf der Walze ④ aufgesteckt sind. Räder bis zur Endposition eindrücken. (L und R beachten).
2. Holme ③ einstecken und festschrauben. Streuguttabelle ⑥ aufkleben.
3. Griff ② auf die Holme ③ schieben und bei Position ① einschrauben (siehe Bild H). Bowdenzug ⑦ durch die Bohrung führen.
4. Hebel ⑧ auf 0-Stellung bringen. Bowdenzug ⑦ in die Lochung der Streuleiste eindrücken (ggf. mit Werkzeug) und mit beiden Schrauben in gestreckter Position festschrauben. Dabei darf der Bowdenzug ⑦ nicht geknickt werden. Walzen-Abdeckung ④ montieren.

Streumenge einstellen:

Gewünschte Streumenge entsprechend der Streuguttabelle ⑥ auf der Einstellskala ① wählen und die Hinweise des Streugutherstellers beachten.

1. Vor dem Einfüllen des Streuguts Hebel ⑧ auf 0-Stellung (geschlossen) bringen.
2. Zum Einstellen der Streumenge den Hebel ⑧ an gewünschter Stelle der Einstellskala ① wieder einrasten lassen.

Bei Unterbrechung und zum Transport den Hebel ⑧ auf 0-Stellung bringen. Auf 0-Stellung den Streuwagen immer ziehen (Freilauf-Funktion). Bei der Wende (Bild W) rückwärts fahren und den Freilauf nutzen (verhindert ungleichmäßiges Ausbringen). Dabei kann eine geringe Menge Streugut ausgestreut werden. Für die Freilauf-Funktion müssen min. 750 g Streugut eingefüllt sein.

GB

Assembly:

1. Assemble cylinder ④. Ensure that the two collars ⑤ are fitted to the cylinder ④. Push wheels in to end position. (Observe L and R).
2. Insert the beams ③ and screw tightly in place. Stick on the dosage table ⑥.
3. Push handle ② onto the shafts ③ and screw into position ① (see figure H). Feed the Bowden cable ⑦ through the hole.
4. Place lever ⑧ in 0 position. Push Bowden cable ⑦ into the hole of the spreader bar (with tool if necessary) and screw tight in stretched position with the two screws. The Bowden cable ⑦ must not be bent. Fit cylinder cover ④.

Setting the spreading quantity:

Select the spreading quantity you require by referring to the dosage table ⑥ on the setting scale ①. Comply with the instructions given by the grit manufacturer.

1. Before pouring in the spreading material, bring the lever ⑧ into the 0-position (closed).
2. In order to set the spreading quantity, let the lever ⑧ engage in the required position on the setting scale ① again.

When interrupting operation or transporting the device, place the lever ⑧ in the 0-position. Always pull the spreader into 0-position (freewheel function). When turning (Fig. W), move backwards and use freewheel (prevents irregular discharge). Can be used to spread small quantities of

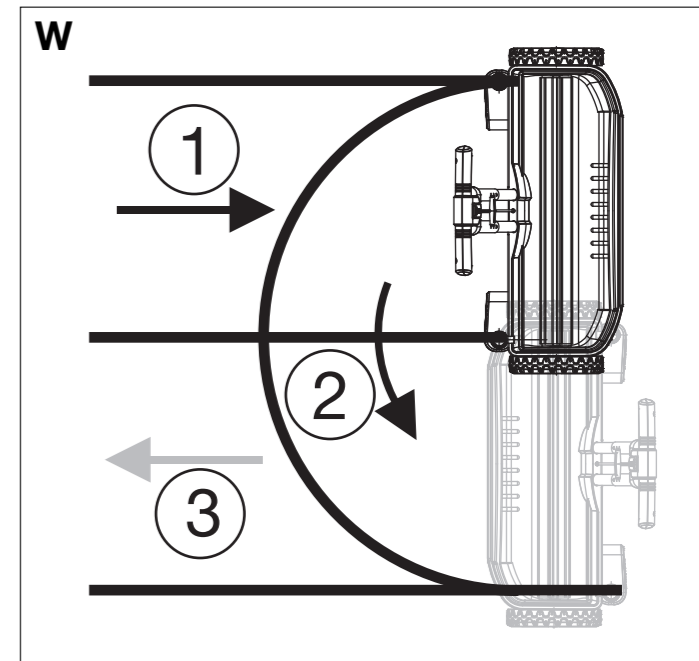

Holmlänge einstellen Bild H:

3-stufige Teleskopierung ①, ② und ③.
→ Holm in gewünschter Stellung einschrauben.

Ordnungsgemäßer Gebrauch:

Der Streuwagen dient der Ausbringung von folgendem Streugut: Dünger, Samen, Kalk, Sand, Splitt, Salz, Winterstreugut.

Wartung / Lagerung:

Nach dem Gebrauch die Walzen-Abdeckung ④ abnehmen, den Streuwagen entleeren und mit Wasser ausspülen. Reste des Streuguts entsprechend den kommunalen Vorschriften entsorgen.

Hinweis:

Die Empfehlungen auf der Streuguttabelle sind wegen den unterschiedlichen Korngrößen von Dünger und Samen nur unverbindliche Richtwerte.

Lieferbares Zubehör für Streuwagen Comfort 500 (Art. 433):

GARDENA Komplettsatz zur Streuweg Markierung Art. 439.

Garantie:

GARDENA gewährt für dieses Produkt 2 Jahre Garantie (ab Kaufdatum). Die Verbrauchsteile (z. B. Dünger) sind von der Garantie ausgeschlossen.

fertiliser, grit etc. At least 750 g fertiliser, grit etc. must be filled for the freewheel function.

Setting the handle length Fig. H:

3-stage telescopic handle ①, ②, and ③.
→ Screw handle in the required position.

Correct usage:

The spreader is used to discharge the following types of material: fertiliser, seeds, lime, sand, chippings, salt and winter grit.

Maintenance / storage:

After use remove cylinder cover ④, empty spreader and rinse out with water. Dispose of any material residue in accordance with local regulations.

Note:

Due to the different sizes of fertiliser and seeds, the information on the dosage table is given for reference purposes only.

Accessories available for Spreader Comfort 500 (Art. 433):

GARDENA complete set for spreading path marking Art. 439.

Warranty:

GARDENA offers a warranty of 2 years (from date of purchase) on this product. The warranty does not cover non-repairable parts (e. g. fertiliser).

P

Montagem:

1. Montar o cilindro [Ⓐ]. Ao fazê-lo, cuidar que as duas guarnições [Ⓑ] estejam colocadas sobre o cilindro [Ⓐ]. Encaixar as rodas até a posição final. (Observar lado direito e esquerdo **(L e R)**).
2. Encaixar as travessas [Ⓒ] e aparafuse-a bem. Colar a tabela de dispersão [Ⓓ].
3. Inserir a pega dentro [Ⓔ] dos tubos [Ⓒ] e enrosque-a na posição [Ⓛ] (ver **imagem H**). Passar o cabo Bowden [Ⓕ] pelo furo.
4. Colocar a alavanca [Ⓜ] na posição 0. Enfiar o cano Bowden [Ⓔ] nos furos da régua de espalhamento (caso necessário, utilizar uma ferramenta) e aparafusar com os dois parafusos na posição inserida. O cabo Bowden [Ⓔ] não deve ser dobrado. Montar a cobertura do cilindro [Ⓒ].

Ajuste da quantidade a dispersar:

Seleccionar a quantidade a dispersar requerida pela tabela de dispersão [Ⓓ] na escala de ajuste [Ⓛ] e ter em atenção as indicações do fabricante fertilizante.

1. Antes de do enchimento com o fertilizante, colocar a alavanca [Ⓜ] na posição 0 (fechado).
2. Para o ajuste da quantidade a dispersar, engatar de novo a alavanca [Ⓜ] na posição desejada da escala de ajuste [Ⓛ].

Após interrupção ou para o transporte, colocar a alavanca [Ⓜ] na posição 0. Arrastar o carro semeador sempre na posição 0 (função roda livre). Numa viragem (**fig. W**) recuar e utilizar a roda livre (evita dispersão irregular). Aqui pode ser distribuída uma pequena quantidade de material de espalhamento. Para o funcionamento com roda livre, têm de estar atestados, pelo menos, 750 g de material de espalhamento.

Service

Deutschland / Germany
GARDENA
Manufacturing GmbH
Central Service
Hans-Lorenser-Str. 40
89079 Ulm
Produktfragen:
(+49) 731 490-123
Reparaturen:
(+49) 731 490-290
service@gardena.com

Argentina
Husqvarna Argentina S.A.
Vera 745
(C1414A00) Buenos Aires
Phone: (+ 54) 11 4858-5000
diego.poggi@ar.husqvarna.com

Australia
Husqvarna Australia Pty. Ltd.
Locked Bag 5,
Central Coast BC, NSW 2252
Phone: 0061 24352 7400
customer.service@husqvarna.com.au

Austria / Österreich
Husqvarna Austria GmbH
Consumer Products
Industriezeile 36
4010 Linz
Phone: (+43) (0) 732/77 01 01-90
consumer.service@husqvarna.at

Belgium
GARDENA Belgium NV/SA
Leuvensesteenweg 555 b10
1930 Zaventem
Phone: (+32) 27 20 921 2
info@gardena.be

Brazil
Palash Importação e Comércio Ltda
Rua São João do Araguaia, 338
Barueri – SP – CEP: 06409-060
Phone: (+55) 11 4198-9777
eduardo@palash.com.br

Bulgaria
Husqvarna Bulgaria Eood
72 Andrey Ljapchev Blvd.
1799 Sofia
Phone: 02/9 75 30 76

Canada
GARDENA Canada Ltd.
100 Summerlea Road
Brampton, Ontario L6T 4X3
Phone: (+1) 905 792 93 30
info@gardenacanada.com

Chile
Garden Chile S.A.
San Sebastián 2839
Ofic. 701 A
Las Condes - Santiago de Chile
Phone: (+56) 2 20 10 708
garfar_cl@yahoo.com

Costa Rica
Compania Exim
Euroiberoamericana S.A.
Aptdo Postal 1260
San José
Phone: (+506) 223 20 75
exim_euro@racsa.co.cr

Croatia
SILK ADRIA d.o.o.
Josipa Lončara 3
10090 Zagreb
Phone: (+385) 1 3794 580
silk.adria@zg.t-com.hr

Cyprus
FARMOKIPIKI LTD
P.O. Box 7098
74, Digeni Akritia Ave.
1641 Nicosia
Phone: (+357) 22 75 47 62
condam@spidernet.com.cy

Czech Republic
GARDENA spol. s.r.o.
Tuřanka 115
CZ-62700 Brno
Phone: (+420) 548 217 777
gardena@gardenabrno.cz

Denmark
GARDENA
Husqvarna Consumer Outdoor Products
Salgsafdelning Danmark
Box 9003
200 39 Malmö
info@gardena.dk

Estonia
Husqvarna Eesti OÜ
Consumer Outdoor Products
Kesk tee 10, Aaviku küla
Rae vald, Harju maakond 75305
kontakt.etj@husqvarna.ee

Finland
Oy Husqvarna Ab
Consumer Outdoor Products
Lautatarhankatu 8 B / PL 3
00581 HELSINKI
info@gardena.fi

France
Husqvarna France S.A.S.
9 – 11 allée des Pierres Mayettes
ZAC des Barbannières
B.P. 99
92232 Gennevilliers cedex
Phone: (+33) 01 40 85 30 40
service.consommateurs@gardena.fr

Great Britain
Husqvarna UK Ltd
Preston Road
Aycliffe Industrial Park
Newton Aycliffe
Co Durham
DL5 6UP
info.gardena@husqvarna.co.uk

Greece
HUSQVARNA ΕΛΛΑΣ Α.Ε.Β.Ε.
Υπ/μα Ηραίου 33Α
Βλ. Πλ. Κορωπίου
19 400 Κορωπί Αττικής
Phone: (+30) 210 6620225 – 6
service@agropkip.gr

Hungary
Husqvarna
Magyarország Kft.
Ezred u. 1 – 3
1044 Budapest
Phone: (+ 36) 80 20 40 33
gardena.gardena.hu

Iceland
Ó. Johnson & Kaaber
Tunguhalsi 1
110 Reykjavik
ooj@ojk.is

Ireland
McLoughlins RS
Unit 5
Norther Cross Business Park
North Road, Finglas
Dublin 11

Italy
GARDENA Italia S.p.A.
Via Donizetti 22
20020 Lainate (Mi)
Phone: (+39) 02.93.94.79.1
info@gardenaitalia.it

Japan
KAKUICHI co., Ltd.
Sumitomo Realty & Development
Kojimachi
BLDG., 8F
5 – 1 Nibanmcyo, chiyoda-ku,
Tokyo 102-0084
Phone: (+81)-(0)3-3264-4721
m_ishihara@kaku-ichi.co.jp

Latvia
SIA „Husqvarna Latvija“
Consumer Outdoor Products
Bākužu iela 6, Rīga, LV-1024
info@husqvarna.lv

Lithuania
UAB Husqvarna Lietuva
Consumer Outdoor Products
Ateities pl. 77C
LT-52104 Kaunas
centras@husqvarna.lt

Luxembourg
Magasins Jules Neuberg
39, rue Jacques Stas
Luxembourg-Gasperich 2549
Case Postale No. 12
Luxembourg 2010
Phone: (+352) - 40 14 01
api@neuberg.lu

Netherlands
GARDENA Nederland B.V.
Postbus 50176
1305 AD ALMERE
Phone: (+31) 36 521 00 00
info@gardena.nl

Ajuste do comprimento das traves Fig. H:

Pega telescópica de 3 estágios [Ⓛ], [Ⓜ] e [Ⓝ].

→ Enroscar a barra na posição desejada.

Utilização correcta:

O carro semeador serve para a dispersão dos seguintes produtos: fertilizantes, sementes, cal, areia, brita, sal, produtos dispersão de Inverno.

Manutenção / armazenamento:

Depois de utilizar, retire a cobertura do rolo [Ⓒ], esvazie o carro semeador e lave com água. Eliminar os restos dos produtos de dispersão, segundo as leis locais correspondentes.

Nota:

As recomendações da tabela de dispersão são somente valores de referência, devido aos diferentes tamanhos dos grãos dos fertilizantes e das sementes.

Acessório disponível para o carro semeador Comfort 500 (Art. 433):

Conjunto completo para a marcação da trajectória de dispersão GARDENA Art. 439.

Garantia:

GARDENA oferece uma garantia de dois (02) anos para este produto (contada a partir da data da compra). As peças de desgaste (p. ex. adubo) estão excluídas da garantia.

Neth. Antilles
Jonka Tuincentrum
Sta. Rosa Weg 196
P.O. Box 8200
Curaçao
Phone: (+599) 9 767 66 55
pgm@jonka.com

New Zealand
Husqvarna New Zealand Ltd.
PO Box 76437
Manukau City 2241
Phone: 0064 9 9202410
sales.nz@husqvarna.co.nz

Norway
GARDENA
Husqvarna Consumer Outdoor Products
Salgskontor Norge
Klevenveien 6
1540 Vestby
info@gardena.no

Poland
HUSQVARNA Poland Spółka z o.o.
ul. Wysockiego 15 b
03-371 Warszawa
Oddział w Szymanowie
Szymanów 9 d
05-532 Baniocha

Portugal
Husqvarna Portugal SA
Sintra Business Park
Edifício 1 · Fracção 0 G
Abrunheira
2710-089 Sintra
info@gardena.pt

Romania
MADEX INTERNATIONAL SRL
Șoseaua Odăii 117 – 123
Sector 1, București,
RO 013603
Phone: (+40) 21 352-7603 / 4 / 5 / 6
madex@gardena.ro

Russia / Россия
000 «Husqvarna»
Leningradskaya street, vladenie 39
Khimki Business Park
Building 2, 4th floor
141400 Moscow Region, Khimki
Phone: +7 (495) 797 26 70

Singapore
HY-RAY PRIVATE LIMITED
40 Jalan Pemimpin
#02-08 Tat Ann Building
Singapore 577185
Phone: (+65) 6253 2277
shiyang@hyray.com.sg

Serbia
DOMEL d.o.o.
Savski Nasip 7
11070 Novi Beograd
Serbia
Phone: (+381) 11 2772 204
miroslav.jejina@domel.co.yu

Slovenia
GARDENA d.o.o.
Brodišče 15
1236 Trzin
Phone: (+386) 1 580 93 32
servis@gardena.si

South Africa
GARDENA
South Africa (Pty.) Ltd.
P.O. Box 11534
Vorna Valley 1686
Phone: (+27) 11 315 02 23
sales@gardena.co.za

Spain
Husqvarna Espana S.A.
C/Basauri, nº 6
La Florida
28023 Madrid
Phone: (+34) 91 708 05 00
(4 líneas)
atencioncliente@gardena.es

Sweden
GARDENA
Husqvarna Consumer Outdoor Products
Försäljningskontor Sverige
Box 9003
20039 Malmö
info@gardena.se

Switzerland / Schweiz
Husqvarna Schweiz AG
Consumer Products
Industriestrasse 10
5506 Mägenwil
Phone: +41 (0) 62 887 37 00
info@gardena.ch

Turkey
GARDENA Dost Diş Ticaret
Müessesilik A.Ş.
Sanayi Cad. Adil Sok. No. 1
34873 Kartal – Istanbul
Phone: (+90) 216 38 93 939
info@gardena-dost.com.tr

Ukraine / Україна
ТОВ «Хускварна Україна»
Васильківська, 34, 204-Г
03022, Київ
Tel.: (+38 044) 498 39 02
info@gardena.ua

USA
GARDENA Canada Ltd.
100 Summerlea Road
Brampton, Ontario L6T 4X3
Phone: (+1) 905 792 93 30
info@gardenacanada.com

433-20.961.04/1009
© GARDENA Manufacturing GmbH
D-89070 Ulm
http://www.gardena.com