

Art. 1188

- D Betriebsanleitung**  
Bodenfeuchtesensor
- 
- GB Operating Instructions**  
Soil Moisture Sensor
- 
- F Mode d'emploi**  
Sonde d'humidité
- 
- NL Instructies voor gebruik**  
Bodemvochtigheidssensor
- 
- S Bruksanvisning**  
Fuktighetsmätare
- 
- I Istruzioni per l'uso**  
Tester di umidità
- 
- E Manual de instrucciones**  
Sensor de humedad
- 
- P Instruções de manejo**  
Sensor de humidade do solo
- 
- DK Brugsanvisning**  
Fugtighedssensor

# GARDENA Soil Moisture Sensor

Welcome to the Garden of GARDENA...



Translation of the original instructions from German.  
Please read these operating instructions carefully and observe the information they contain. Use these operating instructions to familiarise yourself with the GARDENA Soil Moisture Sensor, its proper use and the notes on safety.



For safety reasons, children under the age of 16 as people, who are not familiar with the operating instructions should not use the Soil Moisture Sensor. Persons with reduced physical or mental abilities may use the product only if they are supervised or instructed by a responsible person.

→ Please keep these instructions in a safe place.

## Contents :

1. Where to use Your GARDENA Soil Moisture Sensor	10
2. Safety instructions	10
3. Function	11
4. Initial Operation	11
5. Operation	13
6. Putting into Storage	14
7. Maintenance	14
8. Troubleshooting	15
9. Accessories	15
10. Technical Data	16
11. Service / Warranty	16

## 1. Where to use Your GARDENA Soil Moisture Sensor

### Intended use:

The GARDENA Soil Moisture Sensor is designed to be used solely outdoors in domestic and private gardens and in greenhouses to control sprinklers and watering systems via a GARDENA Water Computer and multi-channel control systems taking account the soil moisture level.  
The Soil Moisture Sensor can also be used together with the GARDENA Fully Automatic Flower Box Watering Set Art. 1407.

### Please note:



**It is not permitted to use the Soil Moisture Sensor for industrial or commercial applications and in conjunction with chemicals, foodstuffs, highly combustible or explosive substances.**

## 2. Safety instructions

### Batteries:

For reasons of operational reliability the Soil Moisture Sensor should only be operated with two 1.5V (alkaline) round cells **type IEC LR14**.

To prevent failure of the Soil Moisture Sensor due to weak batteries in conjunction with a

lengthy absence, batteries should be replaced in due course.

This will depend on the previous operating life of the batteries and the probable length of absence, which should not exceed a year in total.

**Information regarding use:**

The Soil Moisture Sensor is equipped with a safety switch. If the sensor cable is damaged or the batteries flat, the selected watering time of the Water Computer will be used for watering.

The spread of moisture in the soil after watering or rainfall is rather slow. In the worst-case scenario it may happen that irrigation and a rain shower overlap until the required soil moisture is attained.

### 3. Function

With the GARDENA Soil Moisture Sensor the soil moisture level is taken into consideration for watering. The Soil Moisture Sensor measures the soil moisture at the root level of the plants automatically approximately every 10 minutes and sends the measured results to the Water Computer.

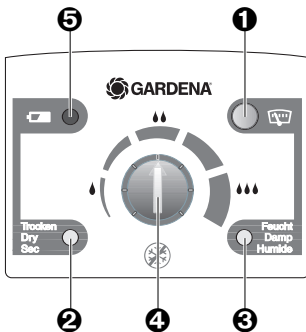
**Control panel of  
Soil Moisture Sensor:**

- 1 Indicator button:** Activates display of moisture level last measured.
- 2 “Dry” LED** Indicates that the Soil Moisture Sensor is measuring dry in relation to the switching controller **4**.
- 3 “Damp” LED:** Indicates that the Soil Moisture Sensor is measuring damp in relation to the switching controller **4**.
- 4 Switching controller:** Sets the soil moisture level at which watering is to take place.
- 5 Battery LED:** If the battery LED flashes the batteries have to be replaced.

If the batteries are flat and are not replaced, the connected Water Computer will function with the watering program selected.

→ Replace batteries (see **7. Maintenance** “*Replace batteries*”).

### 4. Initial Operation

**Insert batteries:**

→ To insert batteries (see **7. Maintenance** “*Replace batteries*”).

**Select correct location for  
Soil Moisture Sensor:**
**Correct location:**

The Soil Moisture Sensor must be positioned **at a location in the watering area** which is exposed to the same climatic conditions as the plants (sun, wind, rain, etc.).

**Incorrect location:**

The Soil Moisture Sensor should not be covered by neighbouring plants. Areas of shade should be avoided. To rule out erroneous reaction results caused by waterlogging, the Soil Moisture Sensor should not be positioned in dips in the ground.

## “Plant” Soil Moisture Sensor:

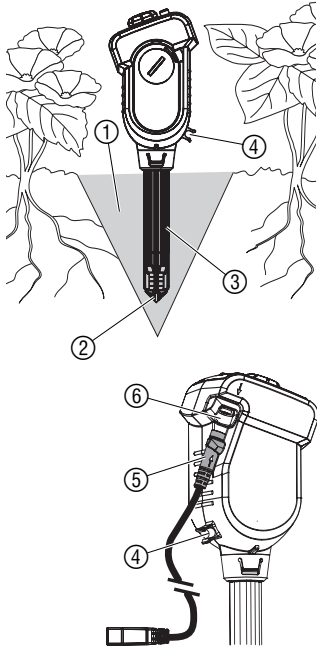

### WARNING!

The tip of the sensor will only measure the soil moisture correctly if the sensor tip is in full contact with the ground on all sides! No air should be trapped at the sensor tip in the ground.

1. Dig a funnel-shaped hole in the ground ① at least 12 cm deep.
2. Break up the soil ① removed and take out any stones.
3. If the soil is dry, moisten.
4. Replace the damp broken-up soil ① in the funnel-shaped hole without packing tight.
5. Immerse entire sensor tip ② in water (felt must be wet).
6. Insert sensor cable (long) ⑤ in the sensor socket ⑥ of the Soil Moisture Sensor (on purchase this is already inserted).
7. Insert the Soil Moisture Sensor to the upper edge of the sensor ③ in the broken-up soil ①.

*Here the sensor tip ② must be in full contact with the damp soil on all sides.*

8. Press down the soil ① around the sensor ③ lightly.  
*The Soil Moisture Sensor should not stand loose in the ground.*
9. Water the area around the Soil Moisture Sensor with approx. 1 litre water.

*Depending on the ground it may take several hours until the Soil Moisture Sensor measures the actual soil moisture.*

## Connect GARDENA Micro-Drip-System:

To ensure that the quantity of water delivered is registered by the sensor tip when using the GARDENA Micro-Drip-System, a drip head must be installed directly above the sensor.

→ Fit a Supply Pipe 4.6 mm (3/16”) with drip head to the drip head holder ④ of the Soil Moisture Sensor.

## Connect adapter cable:

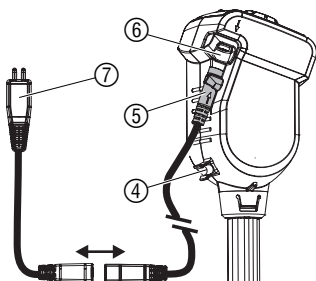

1. Lay the sensor cable ⑤ in / on the ground so that it cannot be damaged or trip people up. The cable should be laid in the ground in a bed of sand to prevent any damage being caused by stones.
2. Fit adapter cable (short) ⑦ to sensor cable ⑤ (on purchase this is already fitted).
3. Insert adapter cable ⑦ in sensor connection of GARDENA Water Computer.

If the sensor cable is not long enough, it can be extended with the GARDENA Extension Cable Art. 1186 (up to 105 m).

## 5. Operation

The water requirement of plants depends on many factors, e.g. type of plant, soil, sunshine, wind. To find the suitable switching point of the Soil Moisture Sensor, it has to be observed during irrigation over a period of approx. 1 - 2 weeks and re-adjusted if necessary. If the soil moisture has exceeded the switching point selected, the watering program of the Water Computer is terminated prematurely or an outstanding irrigation process blocked.

### Select presetting of switching controller:

On delivery, the switching controller is set to the **centre position**, which is suitable for normal non-forest soils (**loamy humus**).

For **sandy soils** the switching controller ⑧ should be preset slightly **to the right** (dampener).

For **potting soil** the switching controller ⑧ should be preset slightly **to the left** (drier).

### Set switching point of Soil Moisture Sensor:

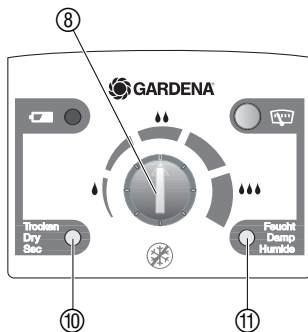

### Increase soil moisture level:

→ If the soil seems too dry for an application (type of soil or plant species), turn the switching controller ⑧ to the right towards **“Damp”** (e.g. with a coin).

### Reduce soil moisture level:

→ If the soil seems too damp for an application (type of soil or plant species), turn the switching controller ⑧ to the left towards **“Dry”** (e.g. with a coin).

### Display soil moisture:

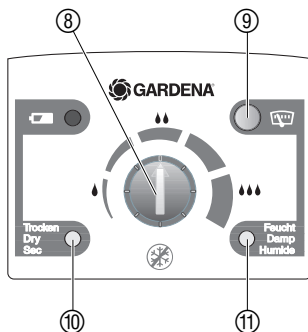

The soil moisture can be displayed at any time with the Soil Moisture Sensor. When the Soil Moisture Sensor shows **“Damp”** ⑪, watering is not carried out.

→ Press indicator button ⑨.

*The soil moisture value last measured is indicated for 1 minute with the relevant LED (**“Dry”** ⑩ or **“Damp”** ⑪).*

During the minute in which the measured result is displayed, the switching controller can be used to find the relevant switching point by turning the switching controller until the display changes from **“Dry”** ⑩ to **“Damp”** ⑪ or vice versa. If the display does not change, the ground is either very dry or very damp.

### Usage:

To keep the soil moisture level as constant as possible, irrigation should be carried out with short watering cycles and short watering times. This especially applies to flower boxes on balconies, which have a watering time of < 5 min.

## 6. Putting into Storage

### Storage / Overwintering:



The storage location must not be accessible to children.

1. Remove batteries from Soil Moisture Sensor.
2. Store the Soil Moisture Sensor in a dry place protected from frost.

### Disposal: (in accordance with RL2002/96/EC)



### Important!

Return spent batteries to one of the sales outlets or dispose of batteries via your municipal recycling collection centre. Only dispose of battery once **discharged**.

The product must not be added to normal household waste. It must be disposed of in line with local environmental regulations.

→ Important: Make sure that the unit is disposed of via your municipal recycling collection centre.

## 7. Maintenance

### Replace batteries:

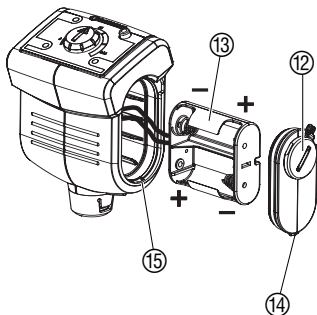

### Caution: Rechargeable batteries should not be used!

1. Unlock battery cover ⑫ with a coin (or large screwdriver) by turning clockwise and remove using gentle pressure.
2. Remove battery holder ⑬ and insert 2 batteries (round cells 1.5 V alkaline type IEC LR14).  
**When doing so, ensure correct polarity (+/-).**
3. Insert battery holder ⑬ in Soil Moisture Sensor. When doing so, make sure that cables are not trapped.
4. Insert catch lug ⑭ of battery cover ⑫ in housing slot ⑮ and press down battery cover ⑫. When doing so, make sure that O-ring is positioned correctly.
5. Relock battery cover ⑫ with a coin (or large screwdriver) by turning anticlockwise.

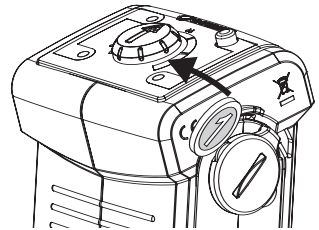

### Clean control panel:

The control panel should be cleaned when soiled.

### No caustic / abrasive cleaning agents should be used.

→ Clean control panel with a damp cloth (do not use solvent).

### Clean /replace sensor tip :

Whenever the Soil Moisture Sensor is relocated, the sensor tip should be cleaned /replaced. The felt on the tip should not come into contact with grease.

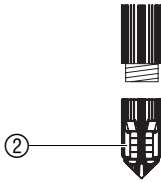

→ Clean sensor tip ② with clear water.

If the felt becomes damaged, the sensor tip can be re-ordered from GARDENA Service.

→ Unscrew sensor tip ② and screw on new tip.

## 8. Troubleshooting

Fault	Possible cause	Remedy
<b>Watering is switched on although soil is damp</b>	Soil Moisture Sensor not positioned in watering area.	→ Position Soil Moisture Sensor in watering area.
	Switching controller too far to the right on "Damp".	→ Turn switching controller to the left accordingly.
	Defective or loose sensor cable.	→ Check sensor cable and connections.
	Batteries spent / inserted incorrectly / wrong battery used.	→ Replace batteries / insert correctly / use alkaline battery.
	Air trapped at sensor tip.	→ Remove trapped air (see 4. Initial Operation " <i>Plant Soil Moisture Sensor</i> ").
<b>Watering is not switched on although soil is dry</b>	Soil Moisture Sensor is in a dip in the ground.	→ Reposition Soil Moisture Sensor at correct location (see 4. Initial Operation " <i>Select correct location for Soil Moisture Sensor</i> ").
	Switching controller too far to the left on "Dry".	→ Turn switching controller to the right accordingly.
<b>Battery display of Soil Moisture Sensor flashing</b>	Batteries of Soil Moisture Sensor are flat.	→ Replace batteries of Soil Moisture Sensor.
	Soil Moisture Sensor defective.	→ Contact GARDENA Service.



In the event of other faults please contact GARDENA Service.  
Repairs should only be carried out by GARDENA service centres or dealers authorised by GARDENA.

## 9. Accessories

<b>GARDENA Extension Cable (length: 10 metres)</b>	Used to extend sensor cable to max. 105 metres.	<b>Art. 1186</b>
<b>GARDENA sensor tip with felt</b>	For replacement with damaged sensor tip.	<b>obtainable via GARDENA Service</b>

## 10. Technical data

### Soil Moisture Sensor (Art. 1188)

<b>Sensor cable:</b>	5 m
<b>Adapter cable:</b>	20 cm
<b>Temperature range:</b>	5 - 60 °C
<b>Batteries:</b>	2 x round cells type IEC LR14 (1.5 V alkaline 7.8 Ah)
<b>Operating life of batteries:</b>	approx. 1 year (with alkaline battery)

## 11. Service / Warranty

### *Warranty*

GARDENA guarantees this product for 2 years (from date of purchase). This guarantee covers all serious defects of the unit that can be proved to be material or manufacturing faults. Under warranty we will either replace the unit or repair it free of charge if the following conditions apply:

- The unit must have been handled properly and in keeping with the requirements of the operating instructions.
- Neither the purchaser or a non-authorized third party have attempted to repair the unit.

As a wear part the sensor tip with felt is not covered by the guarantee.

This manufacturer's guarantee does not affect the user's existing warranty claims against the dealer/seller.

If a fault occurs with your Soil Moisture Sensor, please return the faulty unit together with a copy of the receipt and a description of the fault, with postage paid to one of the GARDENA Service Centres listed on the back of these operating instructions.



<p><b>D</b> <i>Produkthftung</i></p>	<p>Wir weisen ausdrücklich darauf hin, dass wir nach dem Produkthaftungsgesetz nicht für durch unsere Geräte hervorgerufene Schäden einzustehen haben, sofern diese durch unsachgemäße Reparatur verursacht oder bei einem Teileaustausch nicht unsere Original GARDENA Teile oder von uns freigegebene Teile verwendet werden und die Reparatur nicht vom GARDENA Service oder dem autorisierten Fachmann durchgeführt wird. Entsprechendes gilt für Ergänzungssteile und Zubehör.</p>
<p><b>GB</b> <i>Product Liability</i></p>	<p>We expressly point out that, in accordance with the product liability law, we are not liable for any damage caused by our units if it is due to improper repair or if parts exchanged are not original GARDENA parts or parts approved by us, and, if the repairs were not carried out by a GARDENA Service Centre or an authorised specialist. The same applies to spare parts and accessories.</p>
<p><b>F</b> <i>Responsabilité</i></p>	<p>Nous vous signalons expressément que GARDENA n'est pas responsable des dommages causés par ses appareils, dans la mesure où ces dommages seraient causés suite à une réparation non conforme, dans la mesure où, lors d'un échange de pièces, les pièces d'origine GARDENA n'auraient pas été utilisées, ou si la réparation n'a pas été effectuée par le Service Après-Vente GARDENA ou l'un des Centres SAV agréés GARDENA. Ceci est également valable pour tout ajout de pièces et d'accessoires autres que ceux préconisés par GARDENA.</p>
<p><b>NL</b> <i>Productaansprakelijkheid</i></p>	<p>Wij wijzen er nadrukkelijk op, dat wij op grond van de wet aansprakelijkheid voor producten niet aansprakelijk zijn voor schade ontstaan door onze apparaten, indien deze door onvakkundige reparatie veroorzaakt zijn, of er bij het uitwisselen van onderdelen geen gebruik gemaakt werd van onze originele GARDENA onderdelen of door ons vrijgegeven onderdelen en de reparatie niet door de GARDENA technische dienst of de bevoegde vakman uitgevoerd werd. Ditzelfde geldt voor extra-onderdelen en accessoires.</p>
<p><b>S</b> <i>Produktansvar</i></p>	<p>Tillverkaren är inte ansvarig för skada som orsakats av produkten om skadan beror på att produkten har reparerats felaktigt eller om, vid reparation eller utbyte, andra än Original GARDENA reservdelar har använts. Samma sak gäller för kompletteringsdelar och tillbehör.</p>
<p><b>I</b> <i>Responsabilità del prodotto</i></p>	<p>Si rende espressamente noto che, conformemente alla legislazione sulla responsabilità del prodotto, non si risponde di danni causati da nostri articoli se originati da riparazioni eseguite non correttamente o da sostituzioni di parti effettuate con materiale non originale GARDENA o comunque da noi non approvato e, in ogni caso, qualora l'intervento non venga eseguito da un centro assistenza GARDENA o da personale specializzato autorizzato. Lo stesso vale per le parti complementari e gli accessori.</p>
<p><b>E</b> <i>Responsabilidad de productos</i></p>	<p>Advertimos que conforme a la ley de responsabilidad de productos no nos responsabilizamos de daños causados por nuestros aparatos, siempre y cuando dichos daños hayan sido originados por arreglos o reparaciones indebidas, por recambios con piezas que no sean piezas originales GARDENA o bien piezas autorizadas por nosotros, así como en aquellos casos en que la reparación no haya sido efectuada por un Servicio Técnico GARDENA o por un técnico autorizado. Lo mismo es aplicable para las piezas complementarias y accesorios.</p>
<p><b>P</b> <i>Responsabilidade sobre o produto</i></p>	<p>Queremos salientar que segundo a lei da responsabilidade do fabricante, nós não nos responsabilizaremos por danos causados pelo nosso equipamento, quando estes ocorram em decorrência de reparações inadequadas ou da substituição de peças por peças não originais da GARDENA, ou peças não autorizadas. A responsabilidade tornar-se-à nula também depois de reparações realizadas por oficinas não autorizadas pela GARDENA. Esta restrição valerá também para peças adicionais e acessórios.</p>
<p><b>DK</b> <i>Produktansvar</i></p>	<p>Vi gør udtrykkeligt opmærksom på at i henhold til produktansvarsloven er vi ikke ansvarlige for skader forårsaget af vores udstyr, hvis det skyldes uautoriserede reparationer eller hvis dele er skiftet ud og der ikke er anvendt originale GARDENA dele eller dele godkendt af os, eller hvis reparationerne ikke er udført af GARDENA-service eller en autoriseret fagmand. Det samme gælder for ekstra udstyr og tilbehør.</p>

<p><b>D EU-Konformitätserklärung</b>  <b>Maschinenverordnung (9. GSGVO) / EMVG / Niedersp. RL</b>  Der Unterzeichnete GARDENA Manufacturing GmbH, Hans-Lorenser-Str. 40, D-89079 Ulm, bestätigt, dass die nachfolgend bezeichneten Geräte in der von uns in Verkehr gebrachten Ausführung die Anforderungen der harmonisierten EU-Richtlinien, EU-Sicherheitsstandards und produktspezifischen Standards erfüllen. Bei einer nicht mit uns abgestimmten Änderung der Geräte verliert diese Erklärung ihre Gültigkeit.</p>	<p>Bezeichnung des Gerätes: Bodenfeuchtesensor  Description of the unit: Soil Moisture Sensor  Désignation du matériel : Sonde d'humidité  Ormschrijving van het apparaat: Bodemvochtigheidssensor  Produktbeskrivning: Fuktighetsmätare  Descrizione del prodotto: Tester di umidità  Descripción de la mercancía: Sensor de humedad  Descrição do aparelho: Sensor de humidade do solo  Beskrivelse af enhederne: Fugtighedssensor</p>
<p><b>GB EU Certificate of Conformity</b>  The undersigned GARDENA Manufacturing GmbH, Hans-Lorenser-Str. 40, D-89079 Ulm, hereby certifies that, when leaving our factory, the units indicated below are in accordance with the harmonised EU guidelines, EU standards of safety and product specific standards. This certificate becomes void if the units are modified without our approval.</p>	<p>Typ: Art.-Nr.:  Type: Art. No.:  Type : Référence :  Typ: Art. nr.:  Type: Art.nr. : 1188  Modello : Art. :  Tipo: Art. Nº:  Tipo: Art. Nº:  Type: Varenr. :</p>
<p><b>F Certificat de conformité aux directives européennes</b>  Le constructeur, soussigné : GARDENA Manufacturing GmbH, Hans-Lorenser-Str. 40, D-89079 Ulm, déclare qu'à la sortie de ses usines le matériel neuf désigné ci-dessous était conforme aux prescriptions des directives européennes énoncées ci-après et conforme aux règles de sécurité et autres règles qui lui sont applicables dans le cadre de l'Union européenne. Toute modification portée sur ce produit sans l'accord express de GARDENA supprime la validité de ce certificat.</p>	<p>EU-Richtlinien:  EU directives:  Directives européennes :  EU-richtlijnen : 2004/108/EC  EU direktiv :  Directive UE :  Normativa UE :  Directrices da UE :  EU Retningslinier :</p>
<p><b>NL EU-overeenstemmingsverklaring</b>  Ondergetekende GARDENA Manufacturing GmbH, Hans-Lorenser-Str. 40, D-89079 Ulm, bevestigt, dat het volgende genoemde apparaat in de door ons in de handel gebrachte uitvoering voldoet aan de eis van, en in overeenstemming is met de EU-richtlijnen, de EU-veiligheidsstandaard en de voor het product specifieke standaard. Bij een niet met ons afgestemde verandering aan het apparaat verliest deze verklaring haar geldigheid.</p>	<p>Harmonisierte EN EN 55014-1:09/02  Fernbedienung: EN 55014-2:08/02</p>
<p><b>S EU Tillverkarintyg</b>  Undertecknad firma GARDENA Manufacturing GmbH, Hans-Lorenser-Str. 40, D-89079 Ulm, intygar härmed att nedan nämnda produkter överensstämmer med EU:s direktiv, EU:s säkerhetsstandard och produktspecifikation. Detta intyg upphör att gälla om produkten ändras utan vårt tillstånd.</p>	<p>Anbringningsår der CE-Kennzeichnung:  Year of CE marking:  Date d'apposition du marquage CE :  Installatiejaar van de CE-aanduiding:  CE-Märkningsår: 2006  Anno di rilascio della certificazione CE :  Colocación del distintivo CE :  Ano de marcação pela CE :  CE-Mærkningsår :</p>
<p><b>I Dichiarazione di conformità alle norme UE</b>  La sottoscritta GARDENA Manufacturing GmbH, Hans-Lorenser-Str. 40, D-89079 Ulm, certifica che il prodotto qui di seguito indicato, nei modelli da noi commercializzati, è conforme alle direttive armonizzate UE nonché agli standard di sicurezza e agli standard specifici di prodotto. Qualunque modifica apportata al prodotto senza nostra specifica autorizzazione invalida la presente dichiarazione.</p>	<p>Ulm, den 01.08.2006  Ulm, 01.08.2006  Fait à Ulm, le 01.08.2006  Ulm, 01-08-2006  Ulm, 2006.01.08.  Ulm, 01.08.2006  Ulm, 01.08.2006  Ulm, 01.08.2006  Ulm, 01.08.2006</p>
<p><b>E Declaración de conformidad de la UE</b>  El que suscribe GARDENA Manufacturing GmbH, Hans-Lorenser-Str. 40, D-89079 Ulm, declara que la presente mercancía, objeto de la presente declaración, cumple con todas las normas de la UE, en lo que a normas técnicas, de homologación y de seguridad se refiere. En caso de realizar cualquier modificación en la presente mercancía sin nuestra previa autorización, esta declaración pierde su validez.</p>	<p>Der Bevollmächtigte  Authorised representative  Représentant légal  Gemachtigde  Behörig Firmatecknare  Rappresentante autorizzato  Representante autorizado  Representante autorizado  Teknisk direktor</p>
<p><b>P Certificado de conformidad da UE</b>  Os abaixo mencionados GARDENA Manufacturing GmbH, Hans-Lorenser-Str. 40, D-89079 Ulm, por este meio certificam que ao sair da fábrica o aparelho abaixo mencionado está de acordo com as diretrizes harmonizadas da UE, padrões de segurança e de produtos específicos. Este certificado ficará nulo se a unidade for modificada sem a nossa aprovação.</p>	<p>  Peter Lameli  Vice President</p>
<p><b>DK EU Overensstemmelse certificat</b>  Undertegnede GARDENA Manufacturing GmbH, Hans-Lorenser-Str. 40, D-89079 Ulm bekræfter hermed, at enheder listet herunder, ved afsendelse fra fabrikken, er i overensstemmelse med harmoniserede EU retningslinier, EU sikkerhedsstandarder og produktspecifikationsstandarder. Dette certifikat træder ud af kraft hvis enhederne er ændret uden vor godkendelse.</p>	

**Deutschland / Germany**

GARDENA  
Manufacturing GmbH  
Central Service  
Hans-Lorenser-Straße 40  
D-89079 Ulm  
Produktfragen:  
(+49) 731 490-123  
Reparaturen:  
(+49) 731 490-290  
service@gardena.com

**Argentina**

Husqvarna Argentina S.A.  
Vera 745  
(C1414AOO) Buenos Aires  
Phone: (+54) 11 4858-5000  
diego.poggi@ar.husqvarna.com

**Australia**

Husqvarna Australia Pty. Ltd.  
Locked Bag 5  
Central Coast BC  
NSW 2250  
Phone: (+61) 1800 802831  
customer.service@  
husqvarna.com.au

**Austria / Österreich**

Husqvarna Austria GmbH  
Consumer Products  
Industriezeile 36  
4010 Linz  
Tel.: (+43) 732 77 01 01 - 90  
consumer.service@husqvarna.at

**Belgium**

GARDENA Belgium NV/SA  
Sterrebeekstraat 163  
1930 Zaventem  
Phone: (+32) 2 7209212  
Mail: info@gardena.be

**Brazil**

Palash Comércio e  
Importação Ltda.  
Rua São João do Araguaia, 338  
- Jardim Califórnia -  
Barueri - SP - Brasil -  
CEP 06409-060  
Phone: (+55) 11 4198-9777  
eduardo@palash.com.br

**Bulgaria**

Хускварна България ЕООД  
1799 София  
Бул. „Андрей Ляпчев“ № 72  
Тел.: (+359) 2 80 99 424  
www.husqvarna.bg

**Canada / USA**

GARDENA Canada Ltd.  
100 Summerlea Road  
Brampton, Ontario L6T 4X3  
Phone: (+1) 905 792 9330  
info@gardenacanada.com

**Chile**

Antonio Martinic y Cia Ltda.  
Cassillas 272  
Centro de Cassillas  
Santiago de Chile  
Phone: (+56) 2 20 10 708  
garfar\_cl@yahoo.com

**Costa Rica**

Compania Exim  
Euroberoamericana S.A.  
Los Colegios, Moravia,  
200 metros al Sur del Colegio  
Saint Francis - San José  
Phone: (+506) 297 68 83  
exim\_euro@racsa.co.cr

**Croatia**

KLIS d.o.o.  
Stanciceva 79  
10419 Vukovina  
Phone: (+385) 1 622 777 0  
gardena@klis-trgovina.hr

**Cyprus**

FARMOKIPIKI LTD  
P.O. Box 7098  
74, Digeni Akritas Ave.  
1641 Nicosia  
Phone: (+357) 22 75 47 62  
condam@spidernet.com.cy

**Czech Republic**

GARDENA spol. s r.o.  
Tuřanka 115  
627 00 Brno  
Phone: (+420) 548 217 777  
gardena@gardenabrn.cz

**Denmark**

GARDENA  
Husqvarna Consumer Outdoor  
Products  
Salgsafdelning Danmark  
Box 9003  
S-200 39 Malmö  
info@gardena.dk

**Estonia**

Husqvarna Eesti OÜ  
Consumer Outdoor Products  
Kesk tee 10, Aaviku küla  
Rae vald, Harju maakond  
75305  
kontakt.etj@husqvarna.ee

**Finland**

Oy Husqvarna Ab  
Consumer Outdoor Products  
Lautatarhankatu 8 B / PL 3  
00581 HELSINKI  
info@gardena.fi

**France**

GARDENA France  
Immeuble Exposial  
9 - 11 allée des Pierres Mayettes  
ZAC des Barbannières, B.P. 99  
-F- 92232 GENNEVILLIERS  
cedex  
Tél. (+33) 01 40 85 30 40  
service.consommateurs@  
gardena.fr

**Great Britain**

Husqvarna UK Ltd  
Preston Road  
Aycliffe Industrial Park  
Newton Aycliffe  
County Durham  
DL5 6UP  
info.gardena@  
husqvarna.co.uk

**Greece**

HUSQVARNA GREECE S.A.  
Branch of Koropi  
Ifestou 33A  
Industrial Area Koropi  
194 00 Athens - Greece  
V.A.T. EL094094640  
Phone: (+30) 210 66 20 225  
info@husqvarna-consumer.gr

**Hungary**

Husqvarna  
Magyarország Kft.  
Ezred u. 1 - 3  
1044 Budapest  
Phone: (+36) 80 20 40 33  
gardena@gardena.hu

**Iceland**

Ó. Johnson & Kaaber  
Tunguhalsi 1  
110 Reykjavik  
ooj@ojk.is

**Ireland**

Michael McLoughlin & Sons  
Hardware Limited  
Long Mile Road  
Dublin 12

**Italy**

GARDENA Italia S.p.A.  
Via Donizetti 22  
20020 Lainate (Mi)  
Phone: (+39) 02.93.94.79.1  
info@gardenaitalia.it

**Japan**

KAKUICHI Co. Ltd.  
Sumitomo Realty &  
Development Kojimachi  
BLDG., 8F, 5-1 Nibanncyo,  
Chiyoda-ku, Tokyo 102-0084  
Phone: (+81) 33 264 4721  
m\_ishihara@kaku-ichi.co.jp

**Latvia**

SIA „Husqvarna Latvija“  
Consumer Outdoor Products  
Bakūžu iela 6, Rīga, LV-1024  
info@husqvarna.lv

**Lithuania**

UAB Husqvarna Lietuva  
Consumer Outdoor Products  
Atleities pl. 77C  
LT-52104 Kaunas  
centras@husqvarna.lt

**Luxembourg**

Magasins Jules Neuberg  
39, rue Jacques Stas  
Luxembourg-Gasperich 2549  
Case Postale No. 12  
Luxembourg 2010  
Phone: (+352) 40 14 01  
api@neuberg.lu

**Netherlands**

GARDENA Nederland B.V.  
Postbus 50176  
1305 AD ALMERE  
Phone: (+31) 36 521 00 00  
info@gardena.nl

**Neth. Antilles**

Jonka Enterprises N.V.  
Sta. Rosa Weg 196  
P.O. Box 8200, Curaçao  
Phone: (+599) 9 767 66 55  
pgm@jonka.com

**New Zealand**

Husqvarna New Zealand Ltd.  
PO Box 76437  
Manukau City 2241  
Phone: (+64) 09 9202410

**Norway**

GARDENA  
Husqvarna Consumer Outdoor  
Products  
Salgskontor Norge  
Kleiverveien 6  
1540 Vestby  
info@gardena.no

**Poland**

Husqvarna Poland Spółka z o.o.  
Oddział w Szymanowie  
Szymanów 9 d  
05-532 Baniocha  
Phone: (+48) 22 727 56 90  
gardena@gardena.pl

**Portugal**

GARDENA Portugal Lda.  
Sintra Business Park  
Edifício 1, Fracção 0-G  
2710-089 Sintra  
Phone: (+351) 21 922 85 30  
info@gardena.pt

**Romania**

MADEX INTERNATIONAL SRL  
Soseaua Odaii 117-123,  
Sector 1,  
București, RO 013603  
Phone: (+40) 21 352 76 03  
madex@ines.ro

**Russia**

ООО ГАРДЕНА PVC  
123007, г. Москва  
Хорошевское шоссе, д. 32А  
Тел.: (+7) 495 380 31 92  
info@gardena-rus.ru

**Singapore**

Hy - Ray PRIVATE LIMITED  
40 Jalan Pemimpin  
#02-08 Tat Ann Building  
Singapore 577185  
Phone: (+65) 6253 2277  
shiyang@hyray.com.sg

**Slovak Republic**

GARDENA spol. s r.o.  
Tuřanka 115  
627 00 Brno  
Phone: (+420) 548 217 777  
gardena@gardenabrn.cz

**Slovenia**

GARDENA d.o.o.  
Brodšiče 15  
1236 Trzin  
Phone: (+386) 1 580 93 32  
servis@gardena.si

**South Africa**

GARDENA  
South Africa (Pty.) Ltd.  
P.O. Box 11534  
Vorna Valley 1686  
Phone: (+27) 11 315 02 23  
sales@gardena.co.za

**Spain**

GARDENA IBÉRICA S.L.U.  
C/ Basauri, nº 6  
La Florida  
28023 Madrid  
Phone: (+34) 91 708 05 00  
atencioncliente@gardena.es

**Sweden**

GARDENA  
Husqvarna Consumer Outdoor  
Products  
Försäljningskontor Sverige  
Box 9003  
200 39 Malmö  
info@gardena.se

**Switzerland / Schweiz**

GARDENA Schweiz AG  
Consumer Products  
Industriestrasse 10  
5506 Mägenwil  
Phone: (+41) (0) 848 800 464  
info@gardena.ch

**Turkey**

GARDENA / Dost Diş Ticaret  
Müessesilik A.Ş. Sanayi  
Çad. Adil Sokak No. 1  
Kartal - Istanbul  
Phone: (+90) 216 38 93 939  
info@gardena-dost.com.tr

**Ukraine / Україна**

ТОВ «ГАРДЕНА УКРАЇНА»  
Васильківська, 34, 204-Г  
03022, Київ  
Тел. (+38) 044 498 39 02  
info@gardena.ua

1188-20.960.05/0309  
© GARDENA  
Manufacturing GmbH  
D-89070 Ulm  
http://www.gardena.com