

CF 5000 S Art. 7889
CF 8000 S Art. 7890

D Betriebsanleitung
UVC-Mehrkommerfilter-Set

GB Operating Instructions
UV multi-chamber filter set

F Mode d'emploi
Kit de filtration UVC multi-compartiments

NL Gebruiksaanwijzing
UVC-meerkamerfilter-Set

S Driftsanvisningarna
UV multi-kammar filterset

DK Driftsvejledning
UV multi-kammer filtersæt

I Istruzioni per l'uso
Set filtro UVC multi-camera

E Instrucciones de empleo
Kit de filtrado UVC multi-compartimentos

P Manual de instruções
Conjunto filtro UVC multi-compartimentos

D

GB

F

NL

S

DK

I

E

P

GARDENA UV Multi-Chamber Filter Set

CF 5000 S / CF 8000 S

GB



Translation of the original German operating instructions.
Please read the operating instructions carefully and observe the notes given. Use the operating instructions to familiarise yourself with the correct usage of the UV Multi-Chamber Filter Set, and the notes on safety.



For safety reasons, children under 16 as well as persons not familiar with these operating instructions should not use this UV Multi-Chamber Filter Set.

→ Keep these operating instructions in a safe place.

Contents:

1. Range of use for your GARDENA UV Multi-Chamber Filter Set	11
2. Safety Instructions	11
3. Function	13
4. Assembly	13
5. Initial Operation	14
6. Putting out of Operation	14
7. Maintenance.	15
8. Trouble-Shooting	15
9. Technical Data	17
10. Service / Warranty	18

1. Range of use for your GARDENA UV Multi-Chamber Filter Set

Purpose:

The GARDENA UV Multi-Chamber Filter Set is intended for private use in domestic gardens and allotments and should only be used out of doors for cleaning garden ponds with and without fish.

CF 5000 S:
for ponds with a volume of up to 5000 l without fish / 2500 l with fish / 1250 l with koi

CF 8000 S:
for ponds with a volume of up to 8000 l without fish / 4000 l with fish / 2000 l with koi

The GARDENA UV Multi-Chamber Filter Set cleans the pond water biologically and mechanically and reduces the growth of algae. Algae is bound together and pathogens (particularly in fish ponds) are destroyed.

Please note:



The GARDENA UV Multi-Chamber Filter Set is not suitable for industrial use or in combination with chemicals, food, easily combustible and explosive substances.

2. Safety Instructions

→ Comply with the safety instructions on the UV unit.



WARNING!
→ Read the operating instructions before using the equipment for the first time!



DANGER!
→ Ultraviolet radiation. Protect eyes from flash.

This radiation is harmful to eyes and skin.

→ Never operate the UV unit when the housing has been removed.

Electrical safety:

→ Inspect the equipment before use to ensure that the pump and the UV unit, especially the power cable and plug, are undamaged.

Do not use a damaged UV unit or pump.

If the power cable, glass tube, or the housing of the UV device appear to be defective, the UV device must not be operated.

If the pump or UV unit is damaged, please have them checked by our GARDENA Service Centre or an authorised electrician.

The UV-unit and the pump must be operated via a residual-current device (FI-switch) with a nominal fault current ≤ 30 mA (DIN VDE 0100-702 and 0100-738).

→ Please ask your electrician for his advice.

Mains power cables should not have a smaller cross-section than a rubber sheathed cable of the designation H05 RNF. Extension cables must meet the requirements of DIN VDE 0620.

The information on the model plate of the UV unit must match the power supply.

The connection cable of the UV-unit and the pump cannot be replaced.

If the cable is damaged the UV unit must be scrapped.

Do not use extension leads, connection leads or adapters without a protective contact.

The fountain pump must not be operated when there are people in the water.

Swimming pools and garden ponds should be designed according to international and national design regulations.

→ Please ask your electrician for his advice.

Never carry the UV-unit and the pump by the cable. Do not pull on the cable to unplug the plug from the socket.

Please protect the cable from heat, oil and sharp edges. Make sure that connection points remain dry.

Always unplug the equipment when dismantling the set, when it is not in use and before maintenance.

→ Always disconnect the UV unit and the pump from the mains before undertaking any work on them.

For Austria:

In Austria power cables should correspond to ÖVE-EM 42, T2 (2000)/1979 § 22 according to § 2022.1. According to this standard units used in swimming pools and ponds should only be operated via an isolating transformer.

→ Please contact your electrician.

For Switzerland:

In Switzerland mobile appliances which are used outdoors, must be connected via a residual-current device.

Notes:

Never operate the UV unit without water throughput.

Never let the pump run dry; running dry generates heat and will damage the pump.

Sand and other abrasive substances in the liquid cause increased wear and reduce the output of the pump.

The temperature of the liquid used must not be below 4 °C or above 35 °C.

Safety switch:

If the UV light overheats, it is switched off by the built-in thermal protection switch. The UV light switches itself on again automatically when it has cooled down sufficiently.

Due to the integrated safety switch the lamp only comes on when the UV unit is properly installed.

Positioning the filter:

→ Stand or bury the filter housing in a stable position at least 2 m away next to the garden pond.

The filter must be positioned higher than the surface of the pond.

Bacterial Activity:

Extensive bacterial activity arises from + 10 °C onwards.

The filter system is a biological system and therefore, when newly installed, needs a few weeks until it is fully effective.

If possible, the filter should be in permanent operation from spring to autumn and should not dry out.

3. Function

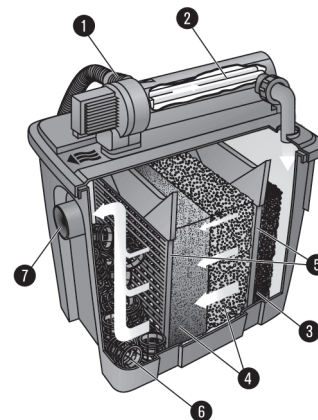

1 Water intake

Universal connection for the pump supply hose in the pond.

2 Phase 1 – UV-radiation

The pond water, which has already undergone preliminary treatment, is subjected to short wave UV-light (ultraviolet rays). During this process, the algal growth is reduced and germs which cause disease in fish ponds are killed.

3 Phase 2 – Water calming and the filtration of coarse contaminants. The water is calmed by the Japanese mat and coarse contaminants are caught and kept there.

4 Phase 3 + 4 – Biological cleaning and the filtration of fine contaminants

• Blue filter sponge / bio-surface elements:

This promotes the growth of aerobic micro-organisms which guarantee the conversion of ammonia into nitrate via nitrite (nitrification).

• Black filter sponge:

This supports the growth of anaerobic micro-organisms which promote denitrification (reduction of nitrate to nitrogen).

5 Phase 5 – Flow direction

The partitioning walls influence the flow direction and speed.

6 Phase 6 – Biological cleaning

Through the organic surface elements, the growth of aerobic micro-organisms is promoted, which guarantees the conversion of ammonia into nitrate via nitrite (nitrification).

7 Water discharge

Water discharge DN 50 for the return flow of the cleansed water.

4. Assembly

Assembling the UV Multi-Chamber Filter:

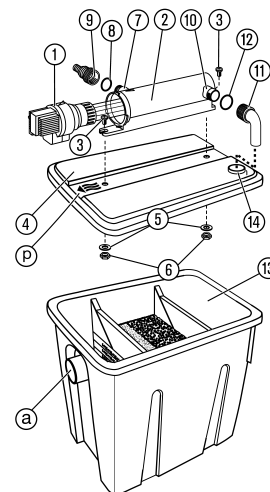

1. Turn UV unit head ① of the UV unit ② anti-clockwise 1 and remove carefully 2 (bayonet fitting) (see 8. Trouble-Shooting "Changing the bulb").
2. Attach the shaped discharge tube ⑪ to the UV outlet ⑩ by screwing on the washer ⑫.
3. Push the two bolts ③ into the guides on the UV unit ② and place on the filter cover ④.
4. From underneath, screw one washer ⑤ and one nut ⑥ respectively on to the bolts ③ and screw the UV unit ② firmly on to the filter cover ④.
5. Push the filter cover ④ with the UV device ② onto the filter housing ⑬, so that the arrow ⑨ is positioned above the outlet ③.
6. Insert UV bulb and fit UV unit (see 8. Trouble-Shooting "Changing the bulb").
7. Screw the universal connection nipple ⑨ on to the UV outlet ⑦ with the O-Ring ⑧.

Connecting pump:

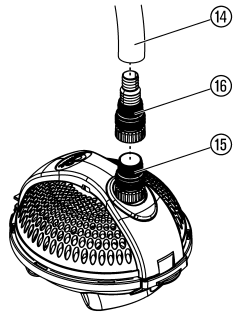

1. Cut the connecting hose (14) between pump and filter to size accordingly.
2. Screw the connection nipple (16) to the pre-mounted adapter (15).
3. Connect the pump and the UV device with the connection hose (14).
If necessary, secure the connection hose with hose clamps (not included in delivery contents.)

5. Initial Operation

Start up UV Multi-Chamber Filter:

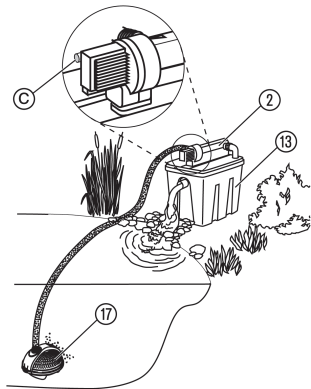

1. Stand the UV multi-chamber filter (2) in a stable position at least 2 m away next to the garden pond.
The outlet may not be more than 1m above the surface of the pond.

Set up the UV multi-chamber filter horizontally so that the filter cannot overflow.

2. Place the pump (17) in a stable position in the garden pond, so that it is completely covered by water.
3. Plug the mains plug of the pump (17) into a 230 V AC socket.
Warning: The pump will start immediately!
4. Plug the mains plug of the UV unit (2) into a 230 V AC socket.
The UV control lamp © is lit blue (more visible at dusk / in darkness).

Return flow tip:

We recommend that you lay the return flow in such a way that the purified water is reintroduced indirectly e. g. via a short stream. This enriches the purified water with additional oxygen.

6. Putting out of Operation

Overwintering / Storage:



The storage location must not be accessible to children.

1. Remove the pump from the pond before the start of the frost season, and clean. Disconnect the hose from the pump, empty the UV Multi-Chamber Filter completely, and clean thoroughly.
2. In order to avoid start-up difficulties in spring, it is recommended to store the pump in a container filled with water in a frost-free location.
The mains plug must not be immersed.

Disposal:
(in accordance with RL2002/96/EC)



The product must not be added to normal household waste. It must be disposed of in line with local environmental regulations.

7. Maintenance



DANGER! Electric shock!

→ Before undertaking maintenance, unplug the UV unit and the pump from the mains!

Cleaning the filter:

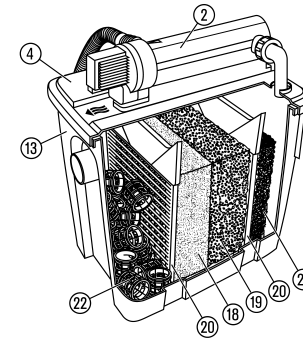

Do not use any chemical cleaning agents so that the bacteria are not killed.

1. Remove filter cover (4) with UV unit (2) from filter housing (18).
2. Remove filter sponges (10) / (19) and clean under running water.
3. Gently rinse the Japanese mat (21) and the organic surface elements in clear water (do not clean under running water).
4. Drain the filter housing (18) completely and clean the filter housing (18) and the partitioning walls (20) under running water.
5. Re-assemble the filter in reverse order (see 4. Assembly "Assembling the UV Multi-Chamber Filter").
6. Restart the filter (see 5. Initial Operation "Start up UV Multi-Chamber Filter").

Cleaning the pump housing of the pump:

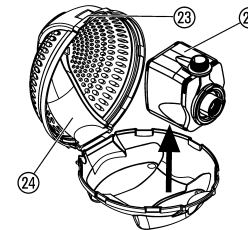

1. Take pump out of the water.
2. Unscrew the connecting hose.
3. Unlock snap fastening (23) and open up the pump housing (24).
4. Take pump (25) out of the pump housing (24).
5. Clean pump housing (24) with a jet of water.
6. Re-assemble pump in reverse order.

Cleaning the UV unit:

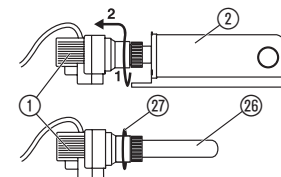

1. Turn the top (1) of the UV unit (2) anticlockwise 1 and carefully remove 2 (bayonet socket).
2. Clean the glass tube (26) (using liquid glass cleaner, for example).
3. Fit the UV unit (2) again in reverse order.

When installing, make sure that the O-ring (27) is inserted correctly in the top of the UV unit (1).

8. Trouble-Shooting



DANGER! Electric shock!

→ Before undertaking Trouble-Shooting, unplug the UV unit and the pump from the mains!

The UV bulb should be replaced after approximately 8,000 operating hours since the UV performance decreases dramatically after this time.

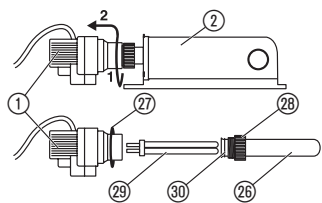
Changing the bulb:

Only bulbs of the type TC-S (UV-C) may be used (e. g. Radium, Philips or Sylvania). The correct GARDENA UV bulb (Art. No. 5388 for CF 5000 F / Art. No. 5390 for CF 8000 F) can be ordered at a dealer or from GARDENA Service.

**WARNING !**

→ Due to the integrated safety switch the lamp only comes on when the UV unit ② is properly installed.

1. Turn the top ① of the UV unit ② anticlockwise 1 and carefully remove 2 (bayonet socket).
2. Carefully unscrew the ring ②⑧.
3. Pull off the glass tube ②⑥ (It may be relatively difficult to remove the glass tube due to mineral deposits.)
4. Take out faulty bulb ②⑨ and insert new bulb.
5. Reassemble the UV unit ② in reverse order.

**WARNING Short-circuit!**

→ The ring ②⑧ must be screwed on firmly again to guarantee that the glass tube ②⑥ is sealed!

When installing, make sure that the O-ring ③⑩ fits properly on the glass tube ②⑥ and that the O-ring ②⑦ is inserted correctly in the top of the UV unit ①.

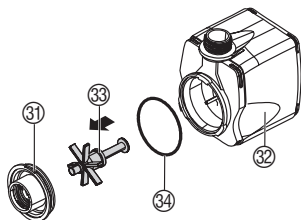
Cleaning the pump:

1. Remove pump from pump housing (see 7. Maintenance "Cleaning the pump housing of the pump").
2. Turn pump cover ③① anti-clockwise and draw vertically out of the motor housing ③② (bayonet fitting).
3. Draw rotor unit ③③ out of motor housing ③② and clean.
4. Push cleaned rotor unit ③③ back into the motor housing ③②.
5. Press pump cover ③① vertically on to the motor housing ③② and close by turning clockwise.
During this, ensure that the O-ring ③④ is installed correctly.
6. Assemble pump in the pump housing.

Fault	Possible Cause	Remedy
The water is not clear	Filter or delivery capacity of the pump not suitable.	→ Check whether UV Multi-Chamber Filter Set is sufficient for the pond (see 1. Range of use of Your GARDENA UV Multi-Chamber Filter Set).
	Too many fish and creatures in the pond.	→ Add up the estimated length of the fish. There should only be "80cm fish" per m ³ water in the pond.

Fault	Possible Cause	Remedy
The water is not clear	The glass tube of the UV unit is dirty.	→ Clean UV unit (see 7. Maintenance).
	The filter sponges are dirty.	→ Clean filter (see 7. Maintenance).
	UV device is dirty.	→ Clean UV device.
The flow is reduced	Pump filter housing is dirty.	→ Clean pump filter housing.
	Rotor unit is blocked.	→ Clean pump.
	UV pilot light is not on	Bulb defective.
UV pilot light is not on	Electrical connections defective.	→ Check electrical connections.
	UV bulb is not mounted completely.	→ Mount UV bulb completely.



For any other malfunctions please contact the GARDENA service department. Repairs must only be carried out by GARDENA service departments or specialist dealers authorised by GARDENA.

9. Technical Data

	CF 5000 S (Art. 7889)	CF 8000 S (Art. 7890)
Rated power, UV unit	7 W	11 W
Power cable, UV unit	3m; H05RN-F3G0,75	3m; H05RN-F3G0,75
Bulb, UV unit	type 7 W TC-S (UV-C)	type 11 W TC-S (UV-C)
Rated power, pump	25 W	40 W
Power cable, pump	10m H05RN-F3G0,75	10m H05RN-F3G0,75
Max. delivery capacity, pump	1,500 l/h	2,500 l/h
Max. delivery head, pump	1.9m	2.2m
Max. operating pressure	0.19 bar	0.22 bar
Mains voltage / mains frequency	230 V / 50 Hz	230 V / 50 Hz
Max. immersion depth	2m	2m
Water discharge	DN 50	DN 50
Connecting hose	3m	3m
Media temperature	4 °C – 35 °C	4 °C – 35 °C

10. Service / Warranty

GB

Warranty:

GARDENA guarantees this product for 2 years (from date of purchase). This guarantee covers all serious defects of the unit that can be proved to be material or manufacturing faults. Under warranty we will either replace the unit or repair it free of charge if the following conditions apply:

- The unit must have been handled properly and in keeping with the requirements of the Operating Instructions.
- Neither the purchaser or a non-authorised third party have attempted to repair the unit.

The wearing parts UV bulb, filter materials and rotor unit are excluded from the warranty.

This manufacturer's guarantee does not affect the user's existing warranty claims against the dealer / seller.

If you have any problems with your UV Multi-Chamber Filter Set, please contact our Service or return the defective unit together with a short description of the problem – in case of guarantee, with a copy of the receipt – postage paid to one of the GARDENA Service Centres listed on the back of this leaflet.

CF 5000 S Art. 7889

Pumpen-Kennlinie
Performance characteristics
Courbes de performance
Prestatiegrafiek
Kapacitetskurva
Ydelses karakteristika
Curva di rendimento
Curva característica
de la bomba
Características de performance

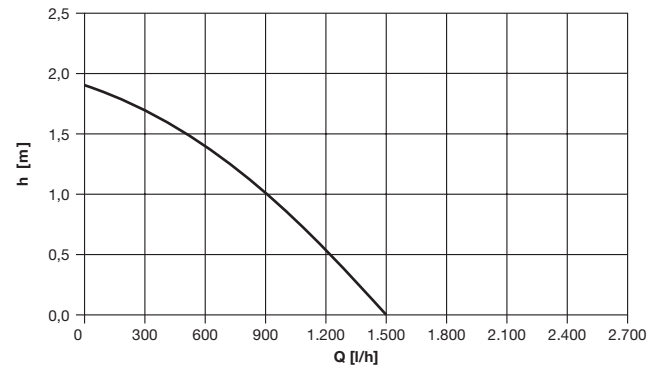

CF 8000 S Art. 7890

Pumpen-Kennlinie
Performance characteristics
Courbes de performance
Prestatiegrafiek
Kapacitetskurva
Ydelses karakteristika
Curva di rendimento
Curva característica
de la bomba
Características de performance

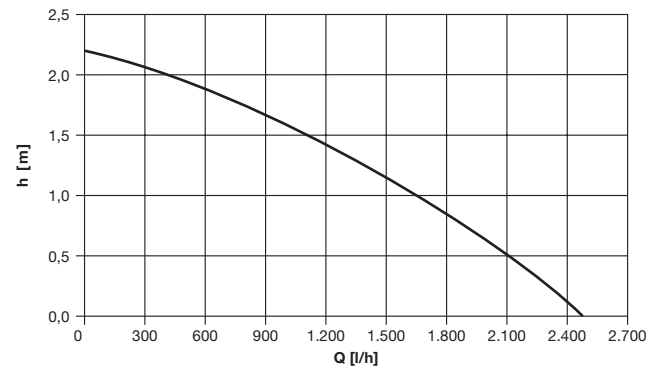

Deutschland / Germany

GARDENA
Manufacturing GmbH
Central Service
Hans-Lorenser-Str. 40
89079 Ulm
Produktfragen:
(+49) 731 490-123
Reparaturen:
(+49) 731 490-290
service@gardena.com

Argentina

Husqvarna Argentina S.A.
Vera 745
(C1414A00) Buenos Aires
Phone: (+ 54) 11 4858-5000
diego.poggi@ar.husqvarna.com

Australia

Husqvarna Australia Pty. Ltd.
Locked Bag 5,
Central Coast BC, NSW 2252
Phone: 0061 24352 7400
customer.service@
husqvarna.com.au

Austria / Österreich

Husqvarna Austria GmbH
Consumer Products
Industriezeile 36
4010 Linz
Phone: (+43) (0) 732/77 01 01-90
consumer.service@husqvarna.at

Belgium

GARDENA Belgium NV/SA
Leuvensesteenweg 555 b10
1930 Zaventem
Phone: (+32) 27 20 921 2
info@gardena.be

Brazil

Palash Importação
e Comércio Ltda
Rua São João do Araguaia, 338
Barueri – SP – CEP: 06409-060
Phone: (+55) 11 4198-9777
eduardo@palash.com.br

Bulgaria

Husqvarna Bulgaria Eood
72 Andrey Ljapchev Blvd.
1799 Sofia
Phone: 02/9 75 30 76

Canada

GARDENA Canada Ltd.
100 Summerlea Road
Brampton, Ontario L6T 4X3
Phone: (+1) 905 792 93 30
info@gardenacanada.com

Chile

Garden Chile S.A.
San Sebastián 2839
Ofic. 701 A
Las Condes - Santiago de Chile
Phone: (+56) 2 20 10 708
garfar_cl@yahoo.com

Costa Rica

Compania Exim
Euroiberoamericana S.A.
Aptdo Postal 1260
San José
Phone: (+506) 223 20 75
exim_euro@racsa.co.cr

Croatia

SILK ADRIA d.o.o.
Josipa Lončara 3
10090 Zagreb
Phone: (+385) 1 3794 580
silk.adria@zg.t-com.hr

Cyprus

FARMOKIPIKI LTD
P.O. Box 7098
74, Digeni Akritia Ave.
1641 Nicosia
Phone: (+357) 22 75 47 62
condam@spidernet.com.cy

Czech Republic

GARDENA spol. s.r.o.
Tuřanka 115
CZ-62700 Brno
Phone: (+420) 548 217 777
gardena@gardenabmo.cz

Denmark

GARDENA
Husqvarna Consumer Outdoor
Products
Salgsafdelning Danmark
Box 9003
200 39 Malmö
info@gardena.dk

Estonia

Husqvarna Eesti OÜ
Consumer Outdoor Products
Kesk tee 10, Aaviku küla
Rae vald, Harju maakond 75305
kontakt.etj@husqvarna.ee

Finland

Oy Husqvarna Ab
Consumer Outdoor Products
Lautatarhankatu 8 B / PL 3
00581 HELSINKI
info@gardena.fi

France

Husqvarna France S.A.S.
9 – 11 allée des Pierres Mayettes
ZAC des Barbanniers
B.P. 99
92232 Gennevilliers cedex
Phone: (+33) 01 40 85 30 40
service.consommateurs@gardena.fr

Great Britain

Husqvarna UK Ltd
Preston Road
Aycliffe Industrial Park
Newton Aycliffe
Co Durham
DL5 6UP
info.gardena@husqvarna.co.uk

Greece

HUSQVARNA ΕΛΛΑΣ Α.Ε.Β.Ε.
Υμη/α Ηραίου 33Α
Βλ. Πλ. Κορωπίου
19 400 Κορωπί Αττικής
Phone: (+30) 210 6620225 – 6
service@agrokop.gr

Hungary

Husqvarna
Magyarország Kft.
Ezred u. 1 – 3
1044 Budapest
Phone: (+ 36) 80 20 40 33
gardena.gardena.hu

Iceland

Ö. Johnson & Kaaber
Tunguhalsi 1
110 Reykjavik
ooj@ojk.is

Ireland

McLoughlins RS
Unit 5
Norther Cross Business Park
North Road, Finlglas
Dublin 11

Italy

GARDENA Italia S.p.A.
Via Donizetti 22
20020 Lainate (MI)
Phone: (+39) 02.93.94.79.1
info@gardenaitalia.it

Japan

KAKUICHI co., Ltd.
Sumitomo Realty & Development
Kojimachi
BLDG., 8F
5 – 1 Nibanncoyo, chiyoda-ku,
Tokyo 102-0084
Phone: (+81)-(0)3-3264-4721
m_ishihara@kaku-ichi.co.jp

Latvia

SIA „Husqvarna Latvija“
Consumer Outdoor Products
Bākūžu iela 6, Rīga, LV-1024
info@husqvarna.lv

Lithuania

UAB Husqvarna Lietuva
Consumer Outdoor Products
Ateities pl. 77C
LT-52104 Kaunas
centras@husqvarna.lt

Luxembourg

Magasins Jules Neuberger
39, rue Jacques Stas
Luxembourg-Gasperich 2549
Case Postale No. 12
Luxembourg 2010
Phone: (+352) - 40 14 01
api@neuberger.lu

Netherlands

GARDENA Nederland B.V.
Postbus 50176
1305 AD ALMERE
Phone: (+31) 36 521 00 00
info@gardena.nl

Neth. Antilles

Jonka Tuincentrum
Sta. Rosa Weg 196
P.O. Box 8200
Curaçao
Phone: (+599) 9 767 66 55
pgm@jonka.com

New Zealand

Husqvarna New Zealand Ltd.
PO Box 76437
Manukau City 2241
Phone: 0064 9 9202410
sales.nz@husqvarna.co.nz

Norway

GARDENA
Husqvarna Consumer Outdoor
Products
Salgskontor Norge
Kleverveien 6
1540 Vestby
info@gardena.no

Poland

HUSQVARNA Poland Spółka z o.o.
ul. Wysockiego 15 b
03-371 Warszawa
Oddział w Szymanowie
Szymanów 9 d
05-532 Baniocza

Portugal

Husqvarna Portugal SA
Sintra Business Park
Edifício 1 - Fracção 0 G
Abrunheira
2710-089 Sintra
info@gardena.pt

Romania

MADEX INTERNATIONAL SRL
Șoseaua Odăii 117 – 123
Sector 1, București,
RO 013603
Phone: (+40) 21 352-7603 / 4 / 5 / 6
madex@gardena.ro

Russia / Россия

ООО «Husqvarna»
Leningradskaya street, vladenie 39
Khimki Business Park
Building 2, 4th floor
141400 Moscow Region, Khimki
Phone: +7 (495) 797 26 70

Singapore

HY-RAY PRIVATE LIMITED
40 Jalan Pemimpin
#02-08 Tat Ann Building
Singapore 577185
Phone: (+65) 6253 2277
shiyang@hyray.com.sg

Serbia

DOMEL d.o.o.
Savski Nasip 7
11070 Novi Beograd
Serbia
Phone: (+381) 11 2772 204
miroslav.jejina@domel.co.yu

Slovenia

GARDENA d.o.o.
Brodšiče 15
1236 Trzin
Phone: (+386) 1 580 93 32
servis@gardena.si

South Africa

GARDENA
South Africa (Pty.) Ltd.
P.O. Box 11534
Vorna Valley 1686
Phone: (+27) 11 315 02 23
sales@gardena.co.za

Spain

Husqvarna Espana S.A.
C/Basauri, nº 6
La Florida
28023 Madrid
Phone: (+34) 91 708 05 00
(4 líneas)
atencioncliente@gardena.es

Sweden

GARDENA
Husqvarna Consumer Outdoor
Products
Försäljningskontor Sverige
Box 9003
20039 Malmö
info@gardena.se

Switzerland / Schweiz

Husqvarna Schweiz AG
Consumer Products
Industriestrasse 10
5506 Mägenwil
Phone: +41 (0) 62 887 37 00
info@gardena.ch

Turkey

GARDENA Dost Diş Ticaret
Mümesillik A.Ş.
Sanayi Çad. Adil Sok. No. 1
34873 Kartal – Istanbul
Phone: (+90) 216 38 93 939
info@gardena-dost.com.tr

Ukraine / Україна

ТОВ «Хускварна Україна»
Васильківська, 34, 204-Г
03022, Київ
Тел.: (+38 044) 498 39 02
info@gardena.ua

USA

GARDENA Canada Ltd.
100 Summerlea Road
Brampton, Ontario L6T 4X3
Phone: (+1) 905 792 93 30
info@gardenacanada.com

7889-20.960.03/1109

© GARDENA Manufacturing GmbH
D-89070 Ulm
http://www.gardena.com