

CRT900

Owner's Manual / 96093001700 / 2009-11

SAFETY RULES



Safe Operation Practices for Walk-Behind Powered Rotary Tillers



TRAINING

- Read the Owner's Manual carefully. Be thoroughly familiar with the controls and the proper use of the equipment. Know how to stop the unit and disengage the controls quickly.
- Never allow children to operate the equipment. Never allow adults to operate the equipment without proper instruction.
- Keep the area of operation clear of all persons, particularly small children, and pets.

PREPARATION

- Thoroughly inspect the area where the equipment is to be used and remove all foreign objects.
- Disengage all clutches and shift into neutral before starting the engine (motor).
- Do not operate the equipment without wearing adequate outer garments. Wear footwear that will improve footing on slippery surfaces.
- Handle fuel with care; it is highly flammable.
- Use an approved fuel container.
- Never add fuel to a running engine or hot engine.
- Fill fuel tank outdoors with extreme care. Never fill fuel tank indoors.
- Replace gasoline cap securely and clean up spilled fuel before restarting.
- Use extension cords and receptacles as specified by the manufacturer for all units with electric drive motors or electric starting motors.
- Never attempt to make any adjustments while the engine (motor) is running (except where specifically recommended by manufacturer).

OPERATION

- Do not put hands or feet near or under rotating parts.
- Exercise extreme caution when operating on or crossing gravel drives, walks, or roads. Stay alert for hidden hazards or traffic. Do not carry passengers.
- After striking a foreign object, stop the engine (motor), remove the wire from the spark plug, thoroughly inspect the tiller for any damage, and repair the damage before restarting and operating the tiller.
- Exercise caution to avoid slipping or falling.
- If the unit should start to vibrate abnormally, stop the engine (motor) and check immediately for the cause. Vibration is generally a warning of trouble.
- Stop the engine (motor) when leaving the operating position.
- Take all possible precautions when leaving the machine unattended. Disengage the tines, shift into neutral, and stop the engine.
- Before cleaning, repairing, or inspecting, shut off the engine and make certain all moving parts have stopped. Disconnect the spark plug wire, and keep the wire away from the plug to prevent accidental starting. Disconnect the cord on electric motors.
- Do not run the engine indoors; exhaust fumes are dangerous.
- Never operate the tiller without proper guards, plates, or other safety protective devices in place.

- Keep children and pets away.
- Do not overload the machine capacity by attempting to till too deep at too fast a rate.
- Never operate the machine at high speeds on slippery surfaces. Look behind and use care when backing.
- Never allow bystanders near the unit.
- Use only attachments and accessories approved by the manufacturer of the tiller.
- Never operate the tiller without good visibility or light.
- Be careful when tilling in hard ground. The tines may catch in the ground and propel the tiller forward. If this occurs, let go of the handlebars and do not restrain the machine.

MAINTENANCE AND STORAGE

- Keep machine, attachments, and accessories in safe working condition.
- Check shear pins, engine mounting bolts, and other bolts at frequent intervals for proper tightness to be sure the equipment is in safe working condition.
- Never store the machine with fuel in the fuel tank inside a building where ignition sources are present, such as hot water and space heaters, clothes dryers, and the like. Allow the engine to cool before storing in any enclosure.
- Always refer to the operator's guide instructions for important details if the tiller is to be stored for an extended period.

- IMPORTANT -

CAUTIONS, IMPORTANTS, AND NOTES ARE A MEANS OF ATTRACTING ATTENTION TO IMPORTANT OR CRITICAL INFORMATION IN THIS MANUAL.

IMPORTANT: USED TO ALERT YOU THAT THERE IS A POSSIBILITY OF DAMAGING THIS EQUIPMENT.



NOTE: Gives essential information that will aid you to better understand, incorporate, or execute a particular set of instructions.



Look for this symbol to point out important safety precautions. It means CAUTION!!! BECOME ALERT!!! YOUR SAFETY IS INVOLVED.



CAUTION: Always disconnect spark plug wire and place wire where it cannot contact spark plug in order to prevent accidental starting when setting up, transporting, adjusting or making repairs.

 **WARNING** 

The engine exhaust from this product contains chemicals known to the State of California to cause cancer, birth defects, or other reproductive harm.

PRODUCT SPECIFICATIONS

Gasoline Capacity: Unleaded Regular	3 Quarts (2,8L)
OIL (API-SG-SL): (Capacity 20 oz/0,6L)	SAE 30 Above 32°F/0°C SAE 5w30 Below 32°F/0°C
Spark Plug:	Champion RC12YC (Gap: .030"/0.76mm)

CONGRATULATIONS on your purchase of a new tiller. It has been designed, engineered and manufactured to give you the best possible dependability and performance.

Should you experience any problems you cannot easily remedy, please contact your nearest authorized service center. We have competent, well-trained technicians and the proper tools to service or repair this unit.

Please read and retain this manual. The instructions will enable you to assemble and maintain your tiller properly. Always observe the "SAFETY RULES".

CUSTOMER RESPONSIBILITIES

- Read and observe the safety rules.
- Follow a regular schedule in maintaining, caring for and using your tiller.
- Follow instructions under "Maintenance" and "Storage" sections of this Owner's Manual.

IMPORTANT: THIS UNIT IS EQUIPPED WITH AN INTERNAL COMBUSTION ENGINE AND SHOULD NOT BE USED ON OR NEAR ANY UNIMPROVED FOREST-COVERED, BRUSH-COVERED OR GRASS COVERED LAND UNLESS THE ENGINE'S EXHAUST SYSTEM IS EQUIPPED WITH A SPARK ARRESTER MEETING APPLICABLE LOCAL LAWS (IF ANY). IF A SPARK ARRESTER IS USED, IT SHOULD BE MAINTAINED IN EFFECTIVE WORKING ORDER BY THE OPERATOR.

IN THE STATE OF CALIFORNIA, A SPARK ARRESTER IS REQUIRED BY LAW (SECTION 4442 OF THE CALIFORNIA PUBLIC RESOURCES CODE). OTHER STATES MAY HAVE SIMILAR LAWS. FEDERAL LAWS APPLY ON FEDERAL LANDS. SEE YOUR AUTHORIZED SERVICE CENTER/DEPARTMENT FOR SPARK ARRESTER.

TABLE OF CONTENTS

SAFETY RULES	2
CUSTOMER RESPONSIBILITIES.....	3
PRODUCT SPECIFICATIONS.....	3
ASSEMBLY	4-6
OPERATION	7-10
MAINTENANCE SCHEDULE	11

MAINTENANCE	11-13
SERVICE & ADJUSTMENTS	14-17
STORAGE.....	18
TROUBLESHOOTING.....	19
REPAIR PARTS-TILLER.....	20-26
WARRANTY.....	BACK COVER

ASSEMBLY

Your new tiller has been assembled at the factory with exception of those parts left unassembled for shipping purposes. To ensure safe and proper operation of your tiller all parts and hardware you assemble must be tightened securely. Use the correct tools as necessary to insure proper tightness.

TOOLS REQUIRED FOR ASSEMBLY

A socket wrench set will make assembly easier. Standard wrench sizes are listed.

- (1) Utility knife
- (1) Tire pressure gauge
- (1) Pair of pliers
- (1) 9/16" wrench

OPERATOR'S POSITION (See Fig. 1)

When right or left hand is mentioned in this manual, it means when you are in the operating position (standing behind tiller handles).

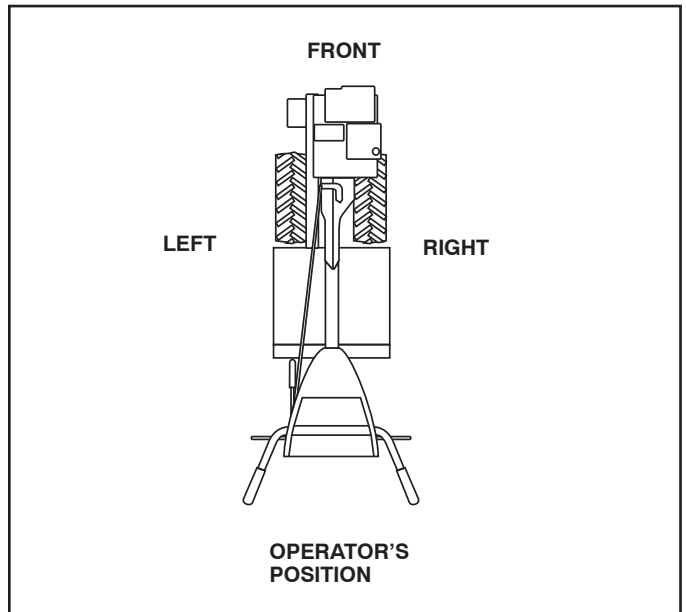
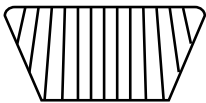
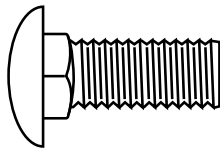

Fig. 1

CONTENTS OF HARDWARE PACK



(2) Handle Locks



(1) Carriage Bolt
3/8-16 UNC x 1 Grade 5

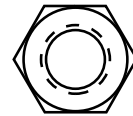

(1) Center Locknut
3/8-16 UNC

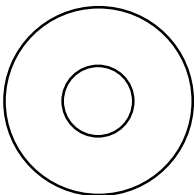

(1) Flat Washer 13/32 x 1 x 11 Gauge



(1) Handle Lock Lever

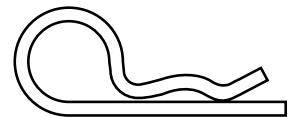

(1) Hairpin Clip

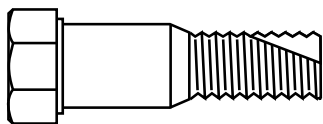

(1) Pivot Bolt
3/8-16 UNC Grade 5

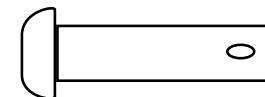
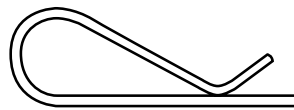

Extra Shear Pins & Clips

ASSEMBLY

UNPACKING CARTON (See Fig. 2)



CAUTION: Be careful of exposed staples when handling or disposing of cartoning material.

IMPORTANT: WHEN UNPACKING AND ASSEMBLING TILLER, BE CAREFUL NOT TO STRETCH OR KINK CABLES.

- While holding handle assembly, cut cable ties securing handle assembly to top frame and depth stake. Let handle assembly rest on tiller.
- Remove top frame of carton.
- Slowly ease handle assembly up and place on top of carton.
- Cut down right hand front and right hand rear corners of carton, lay side carton wall down.
- Remove packing material from handle assembly.

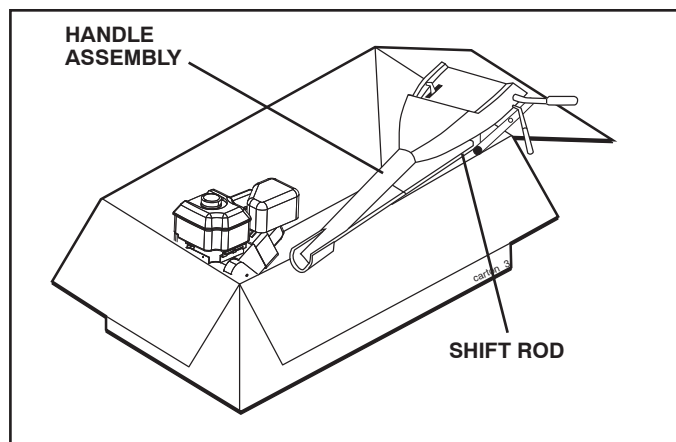

Fig. 2

INSTALL HANDLE (See Figs. 3, 4, and 5)

- Insert one handle lock (with teeth facing outward) in gearcase notch. (Apply grease on smooth side of handle lock to aid in keeping lock in place until handle assembly is lowered into position.)

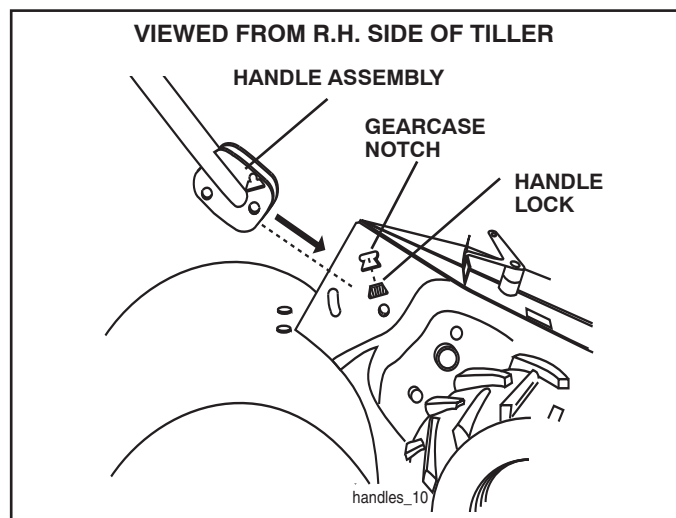

Fig. 3

- Grasp handle assembly. Hold in "up" position. Be sure handle lock remains in gearcase notch. Slide handle assembly into position.

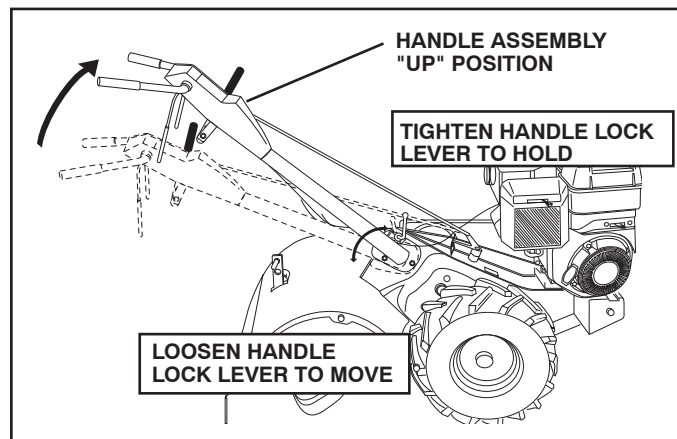

Fig. 4

- Rotate handle assembly down. Insert rear carriage bolt first, with bolt head on L.H. side of tiller and loosely assemble locknut (See Fig. 5).
- Insert pivot bolt in front part of plate and tighten.
- Cut down remaining corners of carton and lay panels flat.
- Lower the handle assembly. Tighten nut on carriage bolt so handle moves with some resistance. This will allow for easier adjustment.
- Place flat washer on threaded end of handle lock lever.
- Insert handle lock lever through handle base and gearcase. Screw in handle lock lever just enough to hold lever in place.
- Insert second handle lock (with teeth inward) in the slot of the handle base (just inside of washer).
- With handle assembly in lowest position, securely tighten handle lock lever by rotating clockwise. Leaving handle assembly in lowest position will make it easier to remove tiller from carton.

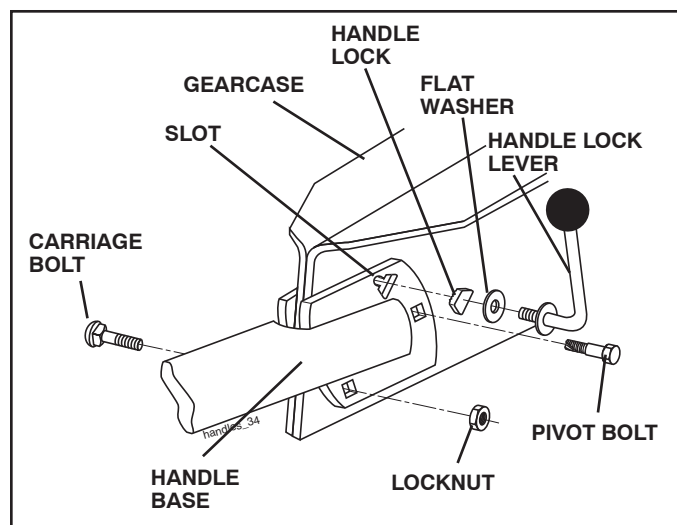

Fig. 5

ASSEMBLY

ATTACH CLUTCH CABLE (See Fig. 6)

- Hook end of clutch cable through hole in control bar bracket.

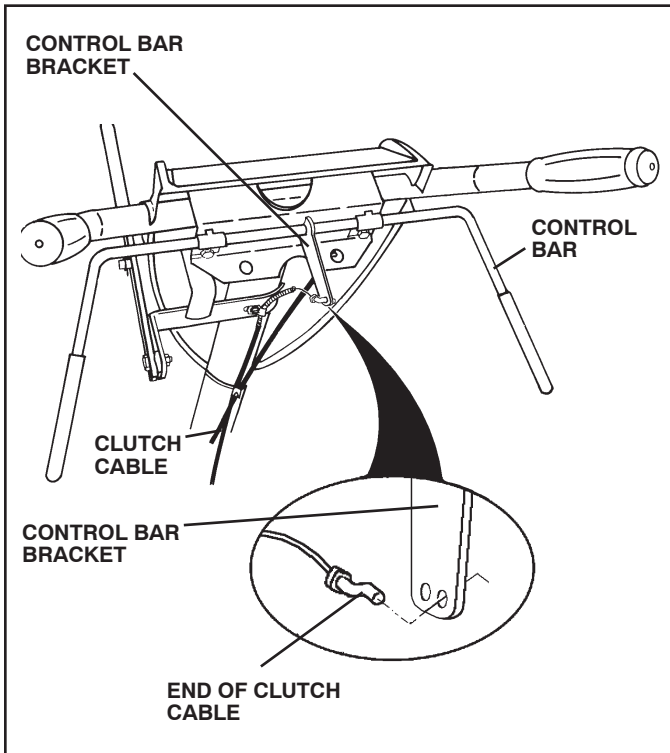

Fig. 6

CONNECT SHIFT ROD (See Fig. 7)

- Insert end of shift rod into hole of shift lever indicator.
- Insert hairpin clip through hole of shift rod to secure.

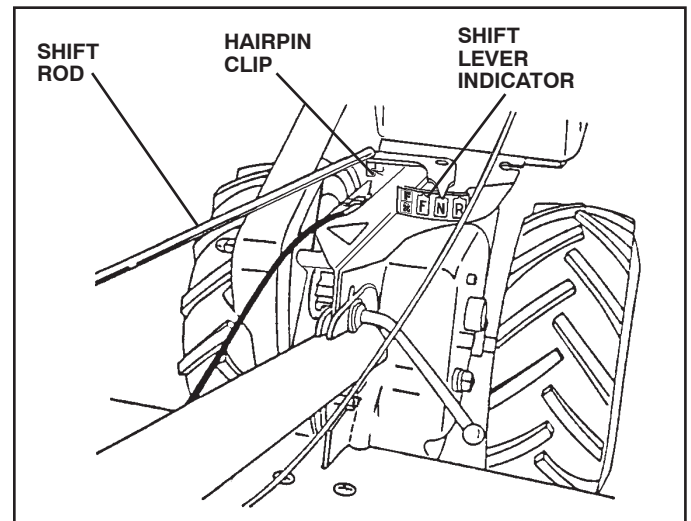

Fig. 7

REMOVE TILLER FROM CRATE

- Make sure shift lever indicator is in "N" position (See Fig. 7)
- Tilt tiller forward by lifting handle. Separate cardboard cover from leveling shield.
- Rotate tiller handle to the right and pull tiller out of carton.

CHECK TIRE PRESSURE

The tires on your unit were overinflated at the factory for shipping purposes. Correct and equal tire pressure is important for best tilling performance.

- Reduce tire pressure to 20 PSI (1.4 kg/cm²).

HANDLE HEIGHT

- Handle height may be adjusted to better suit operator. (See "TO ADJUST HANDLE HEIGHT" in the Service and Adjustments section of this manual).

OPERATION

KNOW YOUR TILLER

READ THIS OWNER'S MANUAL AND SAFETY RULES BEFORE OPERATING YOUR TILLER.

Compare the illustrations with your tiller to familiarize yourself with the location of various controls and adjustments. Save this manual for future reference.

These symbols may appear on your Tiller or in literature supplied with the product. Learn and understand their meaning.

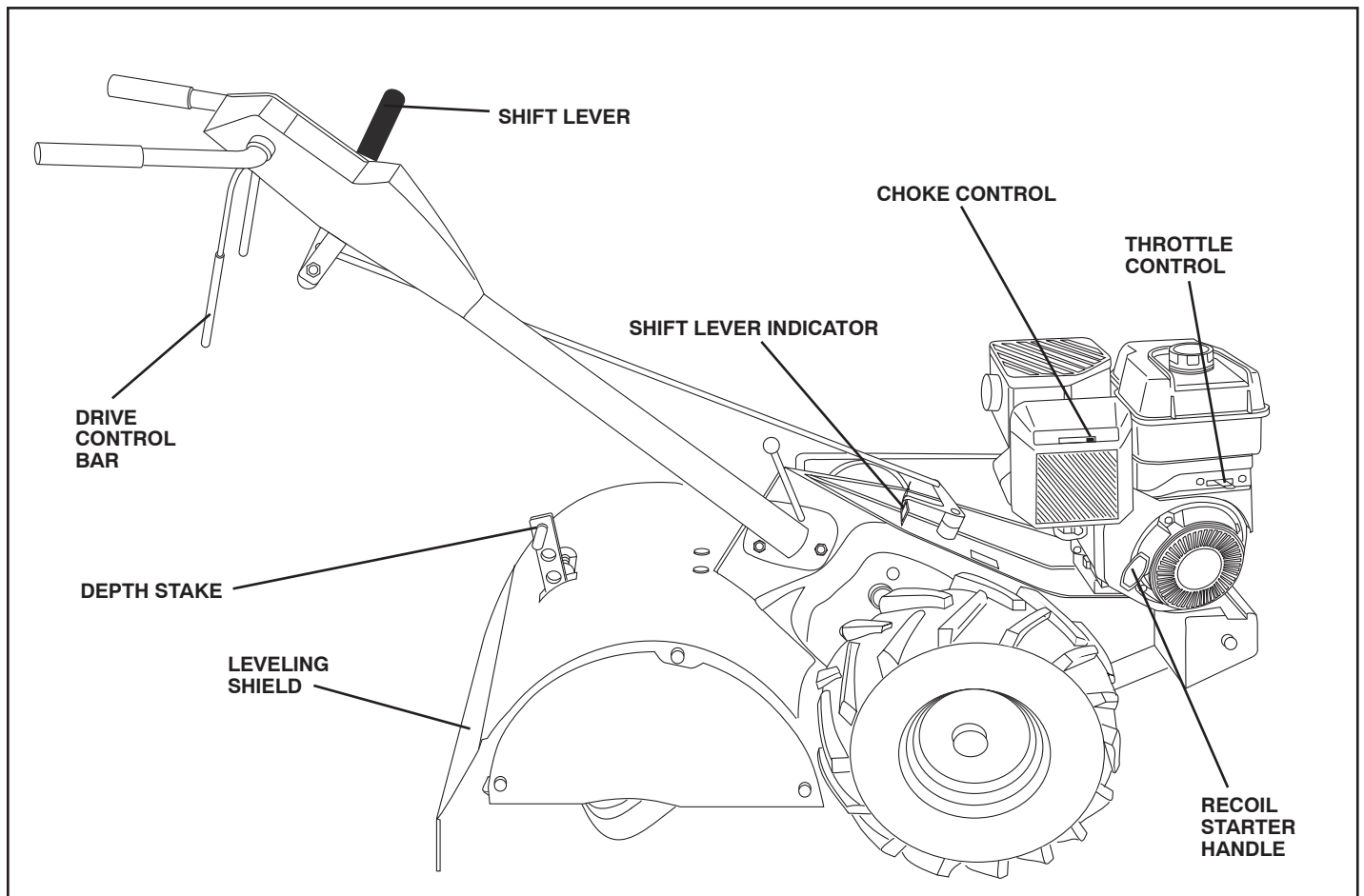
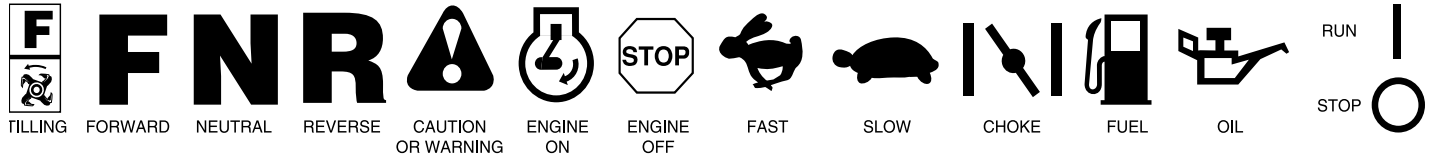

Fig. 8

MEETS ANSI SAFETY REQUIREMENTS

Our tillers conform to the safety standards of the American National Standards Institute.

- CHOKE CONTROL** - Used when starting a cold engine.
- DEPTH STAKE** - Controls depth at which tiller will dig.
- DRIVE CONTROL BAR** - Used to engage tines.
- LEVELING SHIELD** - Levels tilled soil.
- RECOIL STARTER HANDLE** - Used to start the engine.

- SHIFT LEVER** - Used to shift transmission gears.
- SHIFT LEVER INDICATOR** - Shows which gear the transmission is in.
- THROTTLE CONTROL** - Controls engine speed.

OPERATION



The operation of any tiller can result in foreign objects thrown into the eyes, which can result in severe eye damage. Always wear safety glasses or eye shields before starting your tiller and while tilling. We recommend a wide vision safety mask for over spectacles or standard safety glasses.

HOW TO USE YOUR TILLER

Know how to operate all controls before adding fuel and oil or attempting to start engine.

STOPPING (See Fig. 9)

TINES AND DRIVE

- Release drive control bar to stop movement.
- Move shift lever to "N" (neutral) position.

ENGINE

- Move throttle control to "STOP" position.
- Never use choke to stop engine.

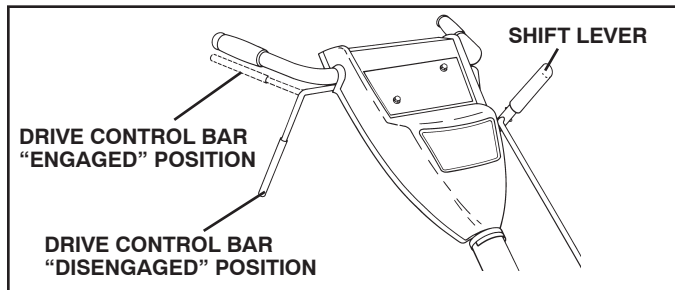

Fig. 9

TINE OPERATION - WITH WHEEL DRIVE

- Always release drive control bar before moving shift lever into another position.
- Tine movement is achieved by moving shift lever to (N) till position and engaging drive control bar.

FORWARD - WHEELS ONLY/TINES STOPPED

- Release drive control bar and move shift lever indicator to "F" (forward) position. Engage drive control bar and tiller will move forward.

REVERSE - WHEELS ONLY/TINES STOPPED

- DO NOT STAND DIRECTLY BEHIND TILLER.
- Release the drive control bar.
- Move throttle control to "SLOW" position.
- Move shift lever indicator to "R" (reverse) position.
- Hold drive control bar against the handle to start tiller movement.

HARD TO SHIFT GEARS

- Briefly engage drive control bar and release or rock tiller forward and backward until are able to shift gears.

DEPTH STAKE (See Fig. 10)

The depth stake can be raised or lowered to allow you more versatile tilling and cultivating, or to more easily transport your tiller.

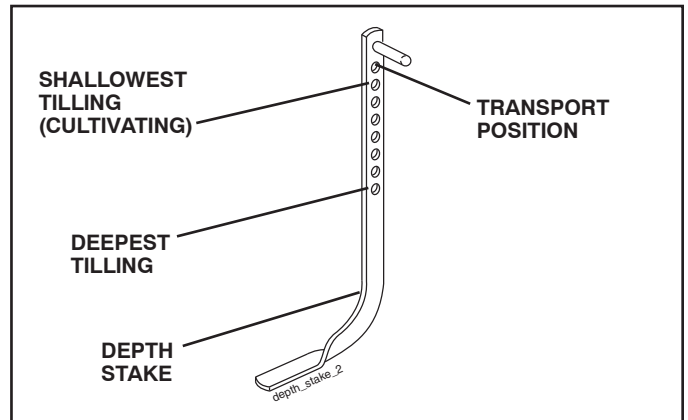

Fig. 10

TILLING (See Fig. 11)

- Release depth stake pin. Pull the depth stake up for increased tilling depth. Place depth stake pin in hole of depth stake to lock in position.
- Place shift lever indicator in tilling position.
- Hold the drive control bar against the handle to start tilling movement. Tines and wheels will both turn.
- Move throttle control to "FAST" position for deep tilling. To cultivate, throttle control can be set at any desired speed, depending on how fast or slow you wish to cultivate.

IMPORTANT: ALWAYS RELEASE DRIVE CONTROL BAR BEFORE MOVING SHIFT LEVER INTO ANOTHER POSITION.

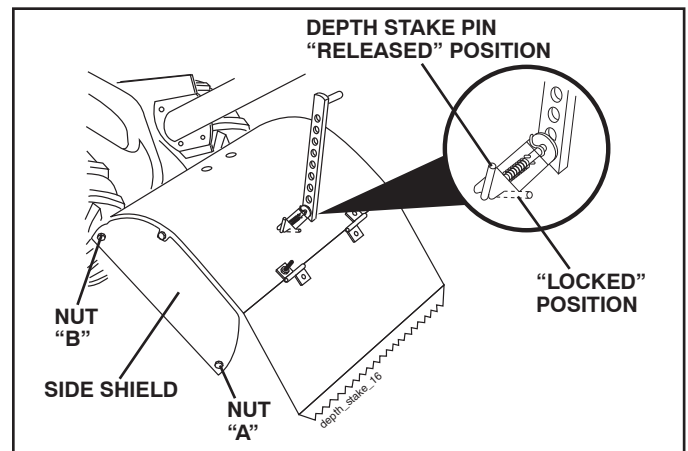

Fig. 11

TURNING

- Release the drive control bar.
- Move throttle control to "SLOW" position.
- Place shift lever indicator in "F" (forward) position. Tines will not turn.
- Lift handle to raise tines out of ground.
- Swing the handle in the opposite direction you wish to turn, being careful to keep feet and legs away from tines.

OPERATION

- When you have completed your turn-around, release the drive control bar and lower handle. Place shift lever in till position and move throttle control to desired speed. To begin tilling, hold drive control bar against the handle.

TO TRANSPORT



CAUTION: Before lifting or transporting, allow tiller engine and muffler to cool. Disconnect spark plug wire. Drain gasoline from fuel tank.

AROUND THE YARD

- Release the depth stake pin. Move the depth stake down to the top hole for transporting the tiller. Place depth stake pin in hole of depth stake to lock in position. This prevents tines from scuffing the ground.
- Place shift lever indicator in “F” (forward) position for transporting.
- Hold the drive control bar against the handle to start tiller movement. Tines will not turn.
- Move throttle control to desired speed.

AROUND TOWN

- Disconnect spark plug wire.
- Drain fuel tank.
- Transport in upright position to prevent oil leakage.

BEFORE STARTING ENGINE

IMPORTANT: BE VERY CAREFUL NOT TO ALLOW DIRT TO ENTER THE ENGINE WHEN CHECKING OR ADDING OIL OR FUEL. USE CLEAN OIL AND FUEL AND STORE IN APPROVED, CLEAN, COVERED CONTAINERS. USE CLEAN FILL FUNNELS.

CHECK ENGINE OIL LEVEL (See Fig.12)

- The engine in your unit has been shipped, from the factory, already filled with SAE 30 summer weight oil.
- With engine level, clean area around oil filler plug and remove plug.
- Engine oil should be to point of overflowing when engine is level. For approximate capacity see “PRODUCT SPECIFICATIONS” on page 3 of this manual. All oil must meet A.P.I. Service Classification SG-SL.
- For cold weather operation you should change oil for easier starting (See oil viscosity chart in the Maintenance section of this manual).
- To change engine oil, see the Maintenance section in this manual.

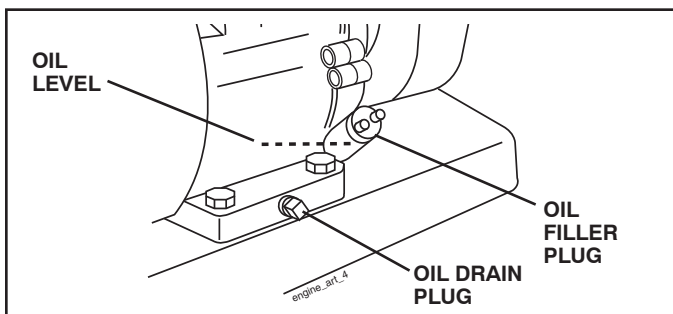

Fig. 12

ADD GASOLINE

- Fill fuel tank to bottom of filler neck. Do not overfill. Use fresh, clean, regular unleaded gasoline with a minimum of 87 octane. (Use of leaded gasoline will increase carbon and lead oxide deposits and reduce valve life). Do not mix oil with gasoline. Purchase fuel in quantities that can be used within 30 days to assure fuel freshness.



CAUTION: Fill to within 1/2 inch of top of fuel tank to prevent spills and to allow for fuel expansion. If gasoline is accidentally spilled, move machine away from area of spill. Avoid creating any source of ignition until gasoline vapors have disappeared.

Wipe off any spilled oil or fuel. Do not store, spill or use gasoline near an open flame.

IMPORTANT: WHEN OPERATING IN TEMPERATURES BELOW 32°F (0°C), USE FRESH, CLEAN WINTER GRADE GASOLINE TO HELP INSURE GOOD COLD WEATHER STARTING.

CAUTION: Alcohol blended fuels (called gasohol or using ethanol or methanol) can attract moisture which leads to separation and formation of acids during storage. Acidic gas can damage the fuel system of an engine while in storage. To avoid engine problems, the fuel system should be emptied before storage of 30 days or longer. Drain the gas tank, start the engine and let it run until the fuel lines and carburetor are empty. Use fresh fuel next season. See Storage Instructions for additional information. Never use engine or carburetor cleaner products in the fuel tank or permanent damage may occur.

TO START ENGINE (See Fig. 13)



CAUTION: Keep drive control bar in “DISENGAGED” position when starting engine.

When starting engine for the first time or if engine has run out of fuel, it will take extra pulls of the recoil starter to move fuel from the tank to the engine.

- Make sure spark plug wire is properly connected.
- Move shift lever indicator to “N” (neutral) position.
- Place throttle control in “FAST” position.
- Turn fuel shut-off valve 1/4 turn to open position.
- Move choke control to choke position.
- Grasp recoil starter handle with one hand and grasp tiller handle with other hand. Pull rope out slowly until engine reaches start of compression cycle (rope will pull slightly harder at this point).
- Pull recoil starter handle quickly. Do not let starter handle snap back against starter.
- If engine fires but does not start, move choke control to half choke position. Pull recoil starter handle until engine starts.

OPERATION

- When engine starts, slowly move choke control to "RUN" position as engine warms up.

NOTE: A warm engine requires less choking to start.

- Move throttle control to desired running position.
- Allow engine to warm up for a few minutes before engaging tines.

NOTE: If at a high altitude (3000 feet) or in cold temperatures (below 32°F), the carburetor fuel mixture may need to be adjusted for best engine performance. See "TO ADJUST CARBURETOR" in the Service and Adjustments section of this manual.

NOTE: If engine does not start, see troubleshooting points.

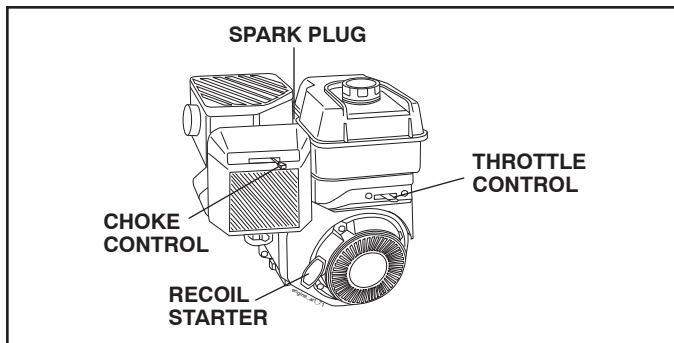

Fig. 13

TILLING HINTS



CAUTION: Until you are accustomed to handling your tiller, start actual field use with throttle in slow position (mid-way between "FAST" and "IDLE").

- Tilling is digging into, turning over, and breaking up packed soil before planting. Loose, unpacked soil helps root growth. Best tilling depth is 4" to 6" (10-15 cm). A tiller will also clear the soil of unwanted vegetation. The decomposition of this vegetable matter enriches the soil. Depending on the climate (rainfall and wind), it may be advisable to till the soil at the end of the growing season to further condition the soil.
- You will find tilling much easier if you leave a row untilled between passes. Then go back between tilled rows. (See Fig. 14) There are two reasons for doing this. First, wide turns are much easier to negotiate than about-faces. Second, the tiller won't be pulling itself, and you, toward the row next to it.

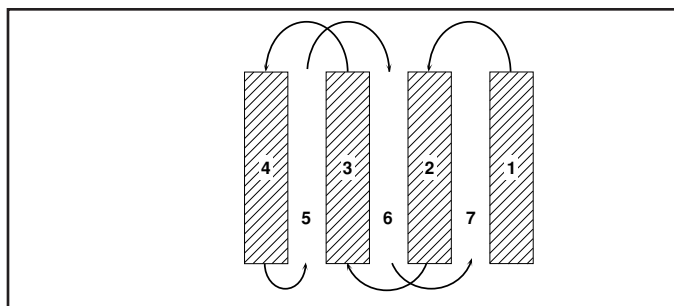

Fig. 14

- Soil conditions are important for proper tilling. Tines will not readily penetrate dry, hard soil which may contribute to excessive bounce and difficult handling of your tiller. Hard soil should be moistened before tilling; however, extremely wet soil will "ball-up" or clump during tilling. Wait until the soil is less wet in order to achieve the best results. When tilling in the fall, remove vines and long grass to prevent them from wrapping around the tine shaft and slowing your tilling operation.
- Do not lean on handle. This takes weight off the wheels and reduces traction. To get through a really tough section of sod or hard ground, apply upward pressure on handle or lower the depth stake.

CULTIVATING

Cultivating is destroying the weeds between rows to prevent them from robbing nourishment and moisture from the plants. At the same time, breaking up the upper layer of soil crust will help retain moisture in the soil. Best digging depth is 1" to 3" (2.5-7.5 cm). Lower the outer side shields to protect small plants from being buried.

- Cultivate up and down the rows at a speed which will allow tines to uproot weeds and leave the ground in rough condition, promoting no further growth of weeds and grass (See Fig. 15).

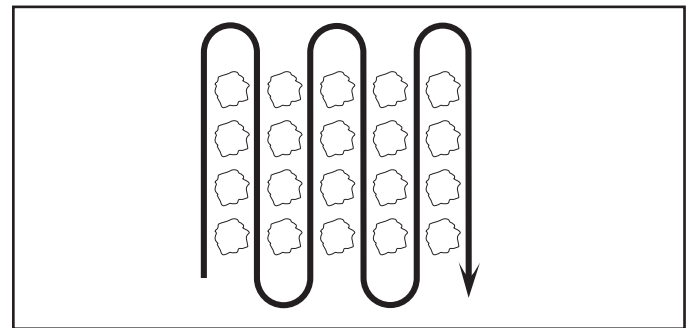

Fig. 15

TINE SHEAR PINS

The tine assemblies on your tiller are secured to the tine shaft with shear pins (See "TINE REPLACEMENT" in the Service and Adjustments section of this manual).

If the tiller is unusually overloaded or jammed, the shear pins are designed to break before internal damage occurs to the transmission.

- If shear pin(s) break, replace only with those shown in the Repair Parts section of this manual.

MAINTENANCE

MAINTENANCE SCHEDULE						SERVICE DATES															
	BEFORE EACH USE	EVERY 5 HOURS	EVERY 25 HOURS	EVERY 50 HOURS	EVERY SEASON																
FILL IN DATES AS YOU COMPLETE REGULAR SERVICE																					
Check Engine Oil Level	✓	✓																			
Change Engine Oil			✓ _{1,2}																		
Oil Pivot Points		✓																			
Inspect Spark Arrester / Muffler				✓																	
Inspect Air Screen	✓																				
Clean or Replace Air Cleaner Cartridge				✓ ₂																	
Clean Engine Cylinder Fins				✓																	
Replace Spark Plug				✓																	
RH Gear Case Grease Fitting (1oz.)					✓																

1 - Change more often when operating under a heavy load or in high ambient temperatures.
 2 - Service more often when operating in dirty or dusty conditions.

GENERAL RECOMMENDATIONS

The warranty on this tiller does not cover items that have been subjected to operator abuse or negligence. To receive full value from the warranty, the operator must maintain tiller as instructed in this manual.

Some adjustments will need to be made periodically to properly maintain your tiller.

All adjustments in the Service and Adjustments section of this manual should be checked at least once each season.

- Once a year you should replace the spark plug, clean or replace air filter, and check tines and belts for wear. A new spark plug and clean air filter assure proper air-fuel mixture and help your engine run better and last longer.

BEFORE EACH USE

- Check engine oil level.
- Check tine operation.
- Check for loose fasteners.

LUBRICATION

Keep unit well lubricated (See "LUBRICATION CHART").

LUBRICATION CHART

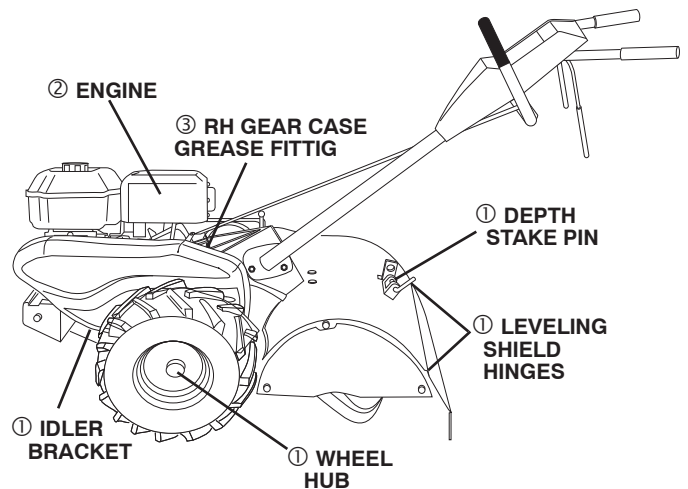

- ① SAE 30 OR 10W-30 MOTOR OIL
- ② REFER TO MAINTENANCE "ENGINE" SECTION
- ③ EP #1 GREASE

MAINTENANCE



Disconnect spark plug wire before performing any maintenance (except carburetor adjustment) to prevent accidental starting of engine.

Prevent fires! Keep the engine free of grass, leaves, spilled oil, or fuel. Remove fuel from tank before tipping unit for maintenance. Clean muffler area of all grass, dirt, and debris.

Do not touch hot muffler or cylinder fins as contact may cause burns.

ENGINE

LUBRICATION

Use only high quality detergent oil rated with API service classification SG-SL. Select the oil's SAE viscosity grade according to your expected temperature.

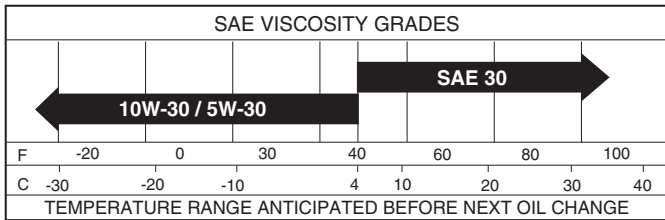

Fig. 16

NOTE: Although multi-viscosity oils (5W-30, 10W-30, etc.) improve starting in cold weather, these multi-viscosity oils will result in increased oil consumption when used above 40°F (4°C). Check your engine oil level more frequently to avoid possible engine damage from running low on oil.

Change the oil after every 25 hours of operation or at least once a year if the tiller is not used for 25 hours in one year.

Check the crankcase oil level before starting the engine and after each five (5) hours of continuous use. Add SAE 30 motor oil or equivalent. Tighten oil filler plug securely each time you check the oil level.

TO CHANGE ENGINE OIL (See Figs. 16 and 17)

Determine temperature range expected before oil change. All oil must meet API service classification SG-SL.

- Be sure tiller is on level surface.
- Oil will drain more freely when warm.
- Use a funnel to prevent oil spill on tiller, and catch oil in a suitable container.
- Remove drain plug. For easier removal of plug use 7/16 12 Pt. socket with extension.)
- Tip tiller forward to drain oil.
- After oil has drained completely, replace oil drain plug and tighten securely.
- Remove oil filler plug. Be careful not to allow dirt to enter the engine.
- Refill engine with oil. See "CHECK ENGINE OIL LEVEL" in the Operation section of this manual.

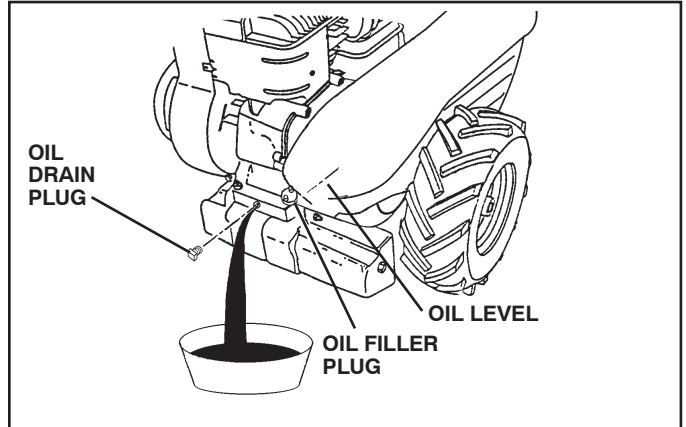

Fig. 17

AIR CLEANER (See Fig. 18)

Service air cleaner cartridge every twenty-five hours, more often if engine is used in very dusty conditions.

- Loosen air cleaner screws, one on each side of cover.
- Remove air cleaner cover.
- Carefully remove air cleaner cartridge. Be careful. Do not allow dirt or debris to fall into carburetor.
- Clean by tapping gently on a flat surface.
- If very dirty or damaged, replace cartridge.
- Clean and replace cover. Tighten screws securely.

IMPORTANT: PETROLEUM SOLVENTS, SUCH AS KEROSENE, ARE NOT TO BE USED TO CLEAN THE CARTRIDGE. THEY MAY CAUSE DETERIORATION OF THE CARTRIDGE. DO NOT OIL CARTRIDGE. DO NOT USE PRESSURIZED AIR TO CLEAN OR DRY CARTRIDGE.

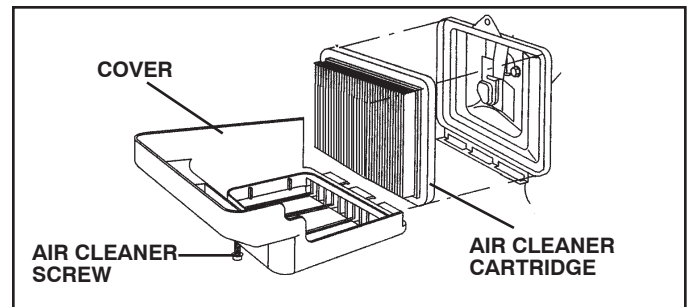

Fig. 18

MAINTENANCE

COOLING SYSTEM (See Fig. 19)

Your engine is air cooled. For proper engine performance and long life keep your engine clean.

- Clean air screen frequently using a stiff-bristled brush.
- Keep cylinder fins, levers, and linkage free of dirt and chaff.

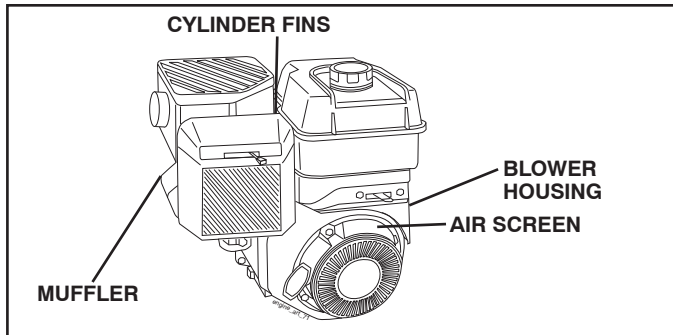

Fig. 19

MUFFLER

Do not operate tiller without muffler. Do not tamper with exhaust system. Damaged mufflers or spark arresters could create a fire hazard. Inspect periodically and replace if necessary. If your engine is equipped with a spark arrester screen assembly, remove every 50 hours for cleaning and inspection. Replace if damaged.

SPARK PLUG

Replace spark plugs at the beginning of each tilling season or after every 50 hours of use, whichever comes first. Spark plug type and gap setting is shown in "PRODUCT SPECIFICATIONS" on page 3 of this manual.

TRANSMISSION

Once a season, lubricate the right hand side gear case grease fitting with 1 oz. of EP #1 Grease.

CLEANING

Do not clean your tiller when the engine and transmission are hot. We do not recommend using pressurized water (garden hose, etc.) to clean your unit unless the gasket area around the transmission and the engine muffler, air filter and carburetor are covered to keep water out. Water in engine will shorten the useful life of your tiller.

- Clean engine, wheels, finish, etc. of all foreign matter.
- Keep finished surfaces and wheels free of all gasoline, oil, etc.
- Protect painted surfaces with automotive type wax.

SERVICE AND ADJUSTMENTS



CAUTION: Disconnect spark plug wire from spark plug and place wire where it cannot come into contact with plug.

TILLER

TO ADJUST HANDLE HEIGHT (See Fig. 20)

Select handle height best suited for your tilling conditions. Handle height will be different when tiller digs into soil.

- First loosen handle lock lever.
- Handle can be positioned at different settings between "HIGH" and "LOW" positions.
- Retighten handle lock lever securely after adjusting.

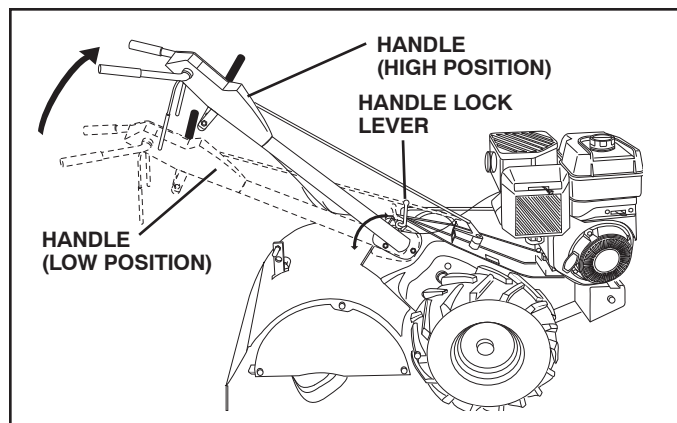

Fig. 20

TIRE CARE



CAUTION: When mounting tires, unless beads are seated, overinflation can cause an explosion.

- Maintain 20 pounds of tire pressure. If tire pressures are not equal, tiller will pull to one side.
- Keep tires free of gasoline or oil which can damage rubber.

TO REMOVE WHEEL (See Fig. 21)

- Place blocks under transmission to keep tiller from tipping.
- Remove hairpin clip and clevis pin from wheel.
- Remove wheel and tire.
- Repair tire and reassemble.

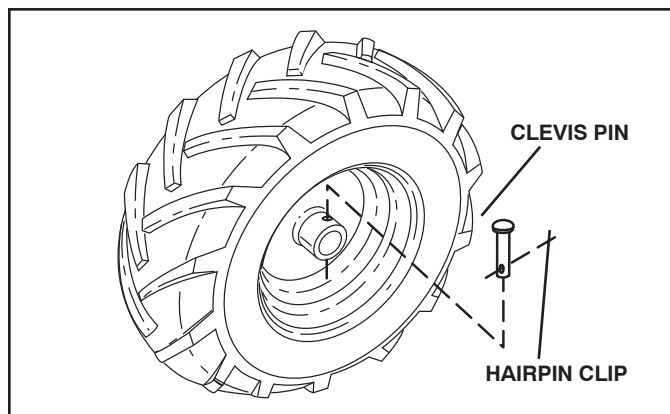

Fig. 21

TO REMOVE BELT GUARD (See Fig. 22)

NOTE: For ease of removal, remove hairpin clip and clevis pin from left wheel. Pull wheel out from tiller about 1 inch.

- Remove two (2) screws from side of belt guard.
- Remove hex nut and washer from bottom of belt guard (located behind wheel).
- Pull belt guard out and away from unit.
- Replace belt guard by reversing above procedure.

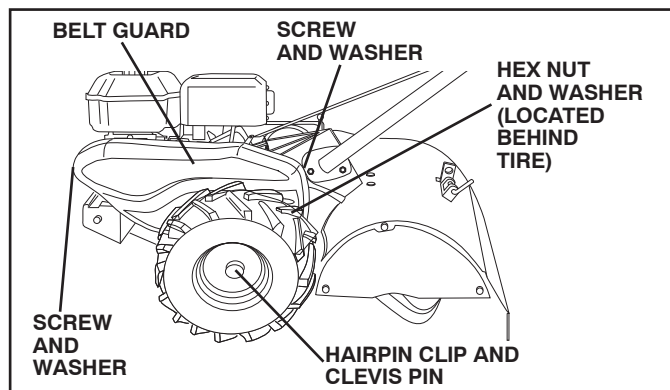

Fig. 22

SERVICE AND ADJUSTMENTS

TO REPLACE GROUND DRIVE BELT

(See Fig. 23)

- Remove belt guard (See "TO REMOVE BELT GUARD" in this section of this manual).
- Remove old belt by slipping off engine pulley first then remove from transmission pulley.
- Place new belt in groove of transmission pulley and into engine pulley. BELT MUST BE IN GROOVE ON TOP OF IDLER PULLEY. NOTE POSITION OF BELT TO GUIDES.
- Check belt adjustment as described below.
- Replace belt guard.
- Reposition wheel and replace clevis pin and hairpin clip.

GROUND DRIVE BELT ADJUSTMENT

(See Fig. 23)

For proper belt tension, the extension spring should have about 5/8 inch stretch when drive control bar is in "ENGAGED" position. This tension can be attained as follows:

- Loosen cable clip screw securing the drive control cable.
- Slide cable forward for less tension and rearward for more tension until about 5/8 inch stretch is obtained while the drive control bar is engaged.
- Tighten cable clip screw securely.

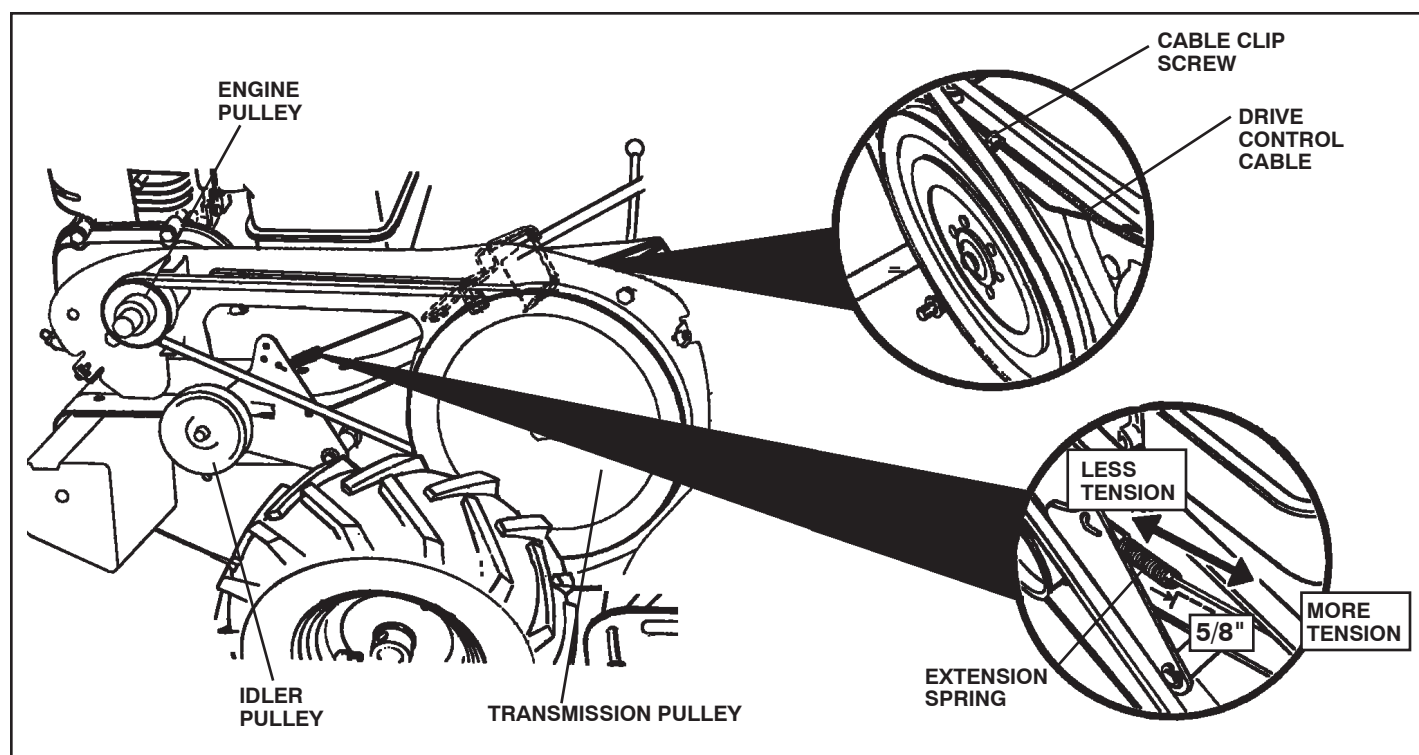

Fig. 23

SERVICE AND ADJUSTMENTS

TINE REPLACEMENT (See Figs. 24, 25 and 26)



CAUTION: Tines are sharp. Wear gloves or other protection when handling tines.

A badly worn tine causes your tiller to work harder and dig more shallow. Most important, worn tines cannot chop and shred organic matter as effectively nor bury it as deeply as good tines. A tine this worn needs to be replaced.

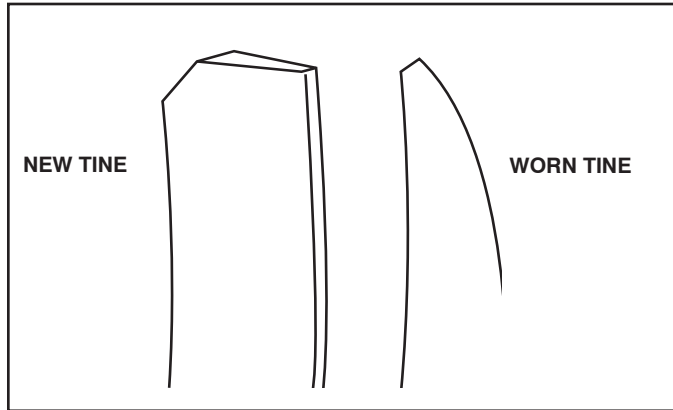

Fig.24

- To maintain the superb tilling performance of this machine the tines should be checked for sharpness, wear, and bending, particularly the tines which are next to the transmission. If the gap between the tines exceeds 3-1/2 inches they should be replaced or straightened as necessary.
- New tines should be assembled as shown in Fig. 26. Sharpened tine edges will rotate rearward from above.

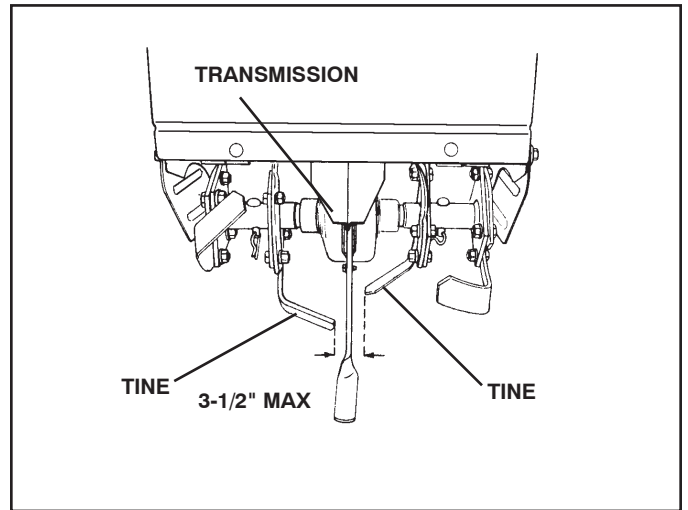

Fig. 25

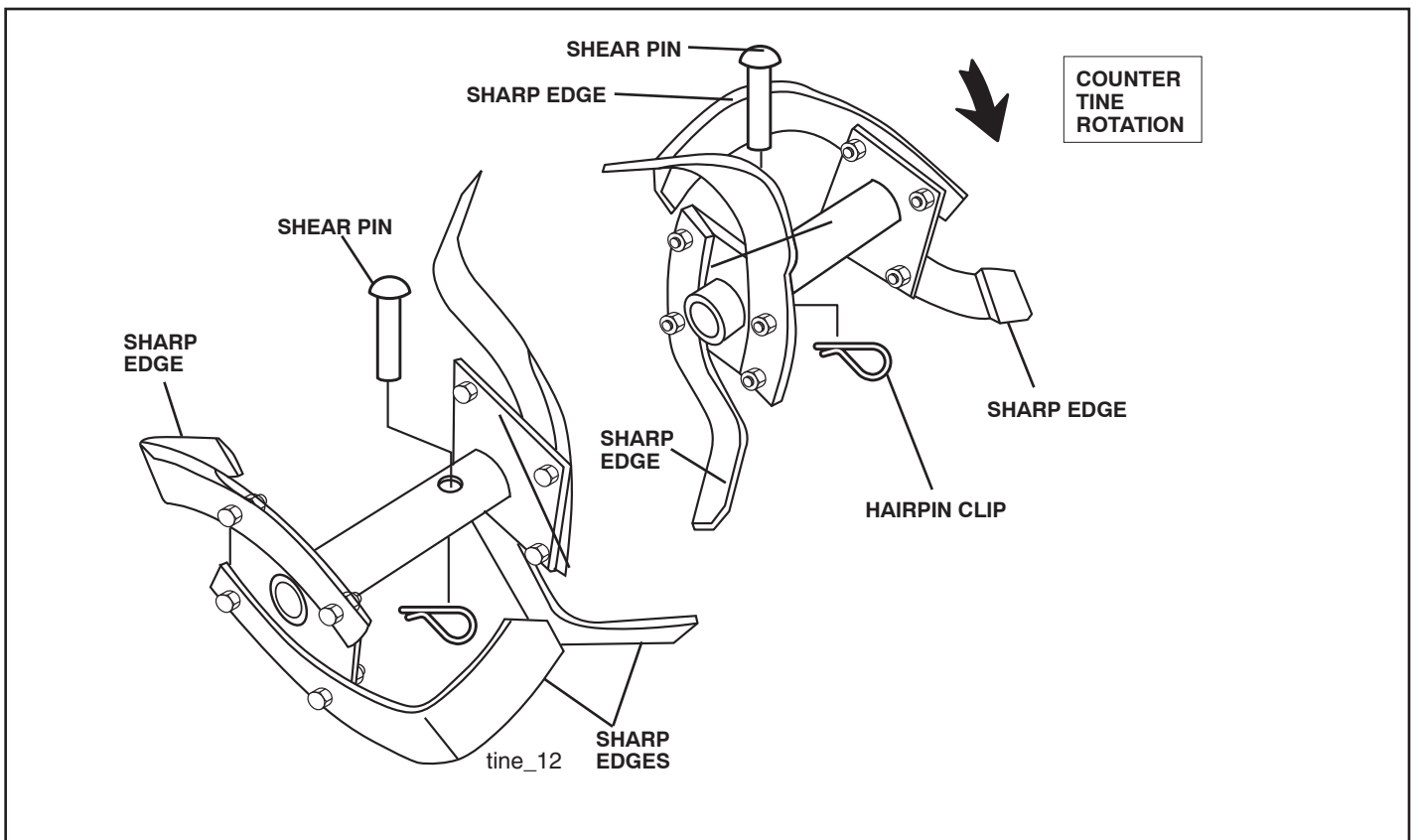

Fig. 26

SERVICE AND ADJUSTMENTS

ENGINE

TO ADJUST CARBURETOR

The carburetor has been preset at the factory and adjustment should not be necessary. However, engine performance can be affected by differences in fuel, temperature, altitude or load. If the carburetor does need adjustment, contact your nearest authorized service center/department

IMPORTANT: NEVER TAMPER WITH THE ENGINE GOVERNOR, WHICH IS FACTORY SET FOR PROPER ENGINE SPEED. OVERSPEEDING THE ENGINE ABOVE THE FACTORY HIGH SPEED SETTING CAN BE DANGEROUS. IF YOU THINK THE ENGINE-GOVERNED HIGH SPEED NEEDS ADJUSTING, CONTACT YOUR NEAREST AUTHORIZED SERVICE CENTER/DEPARTMENT, WHICH HAS THE PROPER EQUIPMENT AND EXPERIENCE TO MAKE ANY NECESSARY ADJUSTMENTS.

STORAGE

Immediately prepare your tiller for storage at the end of the season or if the unit will not be used for 30 days or more.



WARNING: Never store the tiller with gasoline in the tank inside a building where fumes may reach an open flame or spark. Allow the engine to cool before storing in any enclosure.

TILLER

- Clean entire tiller (See “CLEANING” in the Maintenance section of this manual).
- Inspect and replace belts, if necessary (See belt replacement instructions in the Service and Adjustments section of this manual).
- Lubricate as shown in the Maintenance section of this manual.
- Be sure that all nuts, bolts and screws are securely fastened. Inspect moving parts for damage, breakage and wear. Replace if necessary.
- Touch up all rusted or chipped paint surfaces; sand lightly before painting.

ENGINE

FUEL SYSTEM

IMPORTANT: IT IS IMPORTANT TO PREVENT GUM DEPOSITS FROM FORMING IN ESSENTIAL FUEL SYSTEM PARTS SUCH AS THE CARBURETOR, FUEL FILTER, FUEL HOSE, OR TANK DURING STORAGE. ALSO, EXPERIENCE INDICATES THAT ALCOHOL BLENDED FUELS (CALLED GASOHOL OR USING ETHANOL OR METHANOL) CAN ATTRACT MOISTURE WHICH LEADS TO SEPARATION AND FORMATION OF ACIDS DURING STORAGE. ACIDIC GAS CAN DAMAGE THE FUEL SYSTEM OF AN ENGINE WHILE IN STORAGE.

- Empty the fuel tank by starting the engine and let it run until the fuel lines and carburetor are empty.
- Never use engine or carburetor cleaner products in the fuel tank or permanent.
- Use fresh fuel next season.

NOTE: Fuel stabilizer is an acceptable alternative in minimizing the formation of fuel gum deposits during storage. Add stabilizer to gasoline in fuel tank or storage container. Always follow the mix ratio found on stabilizer container. Run engine at least 10 minutes after adding stabilizer to allow the stabilizer to reach the carburetor. Do not empty the gas tank and carburetor if using fuel stabilizer.

ENGINE OIL

Drain oil (with engine warm) and replace with clean oil. (See “ENGINE” in the Maintenance section of this manual).

CYLINDER(S)

- Remove spark plug.
- Pour 1 ounce (29 ml) of oil through spark plug hole into cylinder.
- Pull starter handle slowly several times to distribute oil.
- Replace with new spark plug.

OTHER

- **Do not store gasoline from one season to another.**
- Replace your gasoline can if your can starts to rust. Rust and/or dirt in your gasoline will cause problems.
- If possible, store your unit indoors and cover it to give protection from dust and dirt.
- Cover your unit with a suitable protective cover that does not retain moisture. Do not use plastic. Plastic cannot breathe which allows condensation to form and will cause your unit to rust.

IMPORTANT: NEVER COVER TILLER WHILE ENGINE AND EXHAUST AREAS ARE STILL WARM.

TROUBLESHOOTING POINTS

PROBLEM	CAUSE	CORRECTION
Will not start	<ol style="list-style-type: none"> 1. Out of fuel. 2. Engine not "CHOKED" properly. 3. Engine flooded. 4. Dirty air cleaner. 5. Water in fuel. 6. Clogged fuel tank. 7. Loose spark plug wire. 8. Bad spark plug or improper gap. 9. Carburetor out of adjustment. 10. Oil soaked air filter. 	<ol style="list-style-type: none"> 1. Fill fuel tank. 2. See "TO START ENGINE" in Operation section. 3. Wait several minutes before attempting to start. 4. Clean or replace air cleaner cartridge. 5. Empty fuel tank and carburetor, and refill tank with fresh, clean gasoline. 6. Remove fuel tank and clean. 7. Make sure spark plug wire is seated properly on plug. 8. Replace spark plug or adjust gap. 9. Make necessary adjustments. 10. Replace air filter.
Hard to start	<ol style="list-style-type: none"> 1. Throttle control not set properly. 2. Dirty air cleaner. 3. Bad spark plug or improper gap. 4. Stale or dirty fuel. 5. Loose spark plug wire. 6. Carburetor out of adjustment. 	<ol style="list-style-type: none"> 1. Place throttle control in "FAST" position. 2. Clean or replace air cleaner cartridge. 3. Replace spark plug or adjust gap. 4. Empty fuel tank and refill tank with fresh, clean gasoline. 5. Make sure spark plug wire is seated properly on plug. 6. Make necessary adjustments.
Loss of power	<ol style="list-style-type: none"> 1. Engine is overloaded. 2. Dirty air cleaner. 3. Low oil level/dirty oil. 4. Faulty spark plug. 5. Oil in fuel. 6. Stale or dirty fuel. 7. Water in fuel. 8. Clogged fuel tank. 9. Spark plug wire loose. 10. Dirty engine air screen. 11. Dirty/clogged muffler. 12. Carburetor out of adjustment. 13. Poor compression. 	<ol style="list-style-type: none"> 1. Set depth stake for shallower tilling. 2. Clean or replace air cleaner cartridge. 3. Check oil level/change oil. 4. Clean and regap or change spark plug. 5. Empty and clean fuel tank and refill tank, and clean carburetor. 6. Empty fuel tank and refill tank with fresh, clean gasoline. 7. Empty fuel tank and carburetor, and refill tank with fresh, clean gasoline. 8. Remove fuel tank and clean. 9. Connect and tighten spark plug wire. 10. Clean engine air screen. 11. Clean/replace muffler. 12. Make necessary adjustments. 13. Contact an authorized service center/department.
Engine overheats	<ol style="list-style-type: none"> 1. Low oil level/dirty oil. 2. Dirty engine air screen. 3. Dirty engine. 4. Partially plugged muffler. 5. Improper carburetor adjustment. 	<ol style="list-style-type: none"> 1. Check oil level/change oil. 2. Clean engine air screen. 3. Clean cylinder fins, air screen, and muffler area. 4. Remove and clean muffler. 5. Adjust carburetor to richer position.
Excessive bounce/ difficult handling	<ol style="list-style-type: none"> 1. Ground too dry and hard. 	<ol style="list-style-type: none"> 1. Moisten ground or wait for more favorable soil conditions.
Soil balls up or clumps	<ol style="list-style-type: none"> 1. Ground too wet. 	<ol style="list-style-type: none"> 1. Wait for more favorable soil conditions.
Engine runs but tiller won't move	<ol style="list-style-type: none"> 1. Drive control bar is not engaged. 2. V-belt not correctly adjusted. 3. V-belt is off pulley(s). 	<ol style="list-style-type: none"> 1. Engage drive control. 2. Inspect/adjust V-belt. 3. Inspect V-belt.
Engine runs but labors when tilling	<ol style="list-style-type: none"> 1. Tilling too deep. 2. Throttle control not properly adjusted. 3. Carburetor out of adjustment. 	<ol style="list-style-type: none"> 1. Set depth stake for shallower tilling. 2. Check throttle control setting. 3. Make necessary adjustments.
Tines will not rotate	<ol style="list-style-type: none"> 1. Shear pin(s) broken. 	<ol style="list-style-type: none"> 1. Replace shear pin(s).

REPAIR PARTS

TILLER - - MODEL NUMBER CRT900 (96093001700), PRODUCT NUMBER 960 93 00-17
HANDLE ASSEMBLY

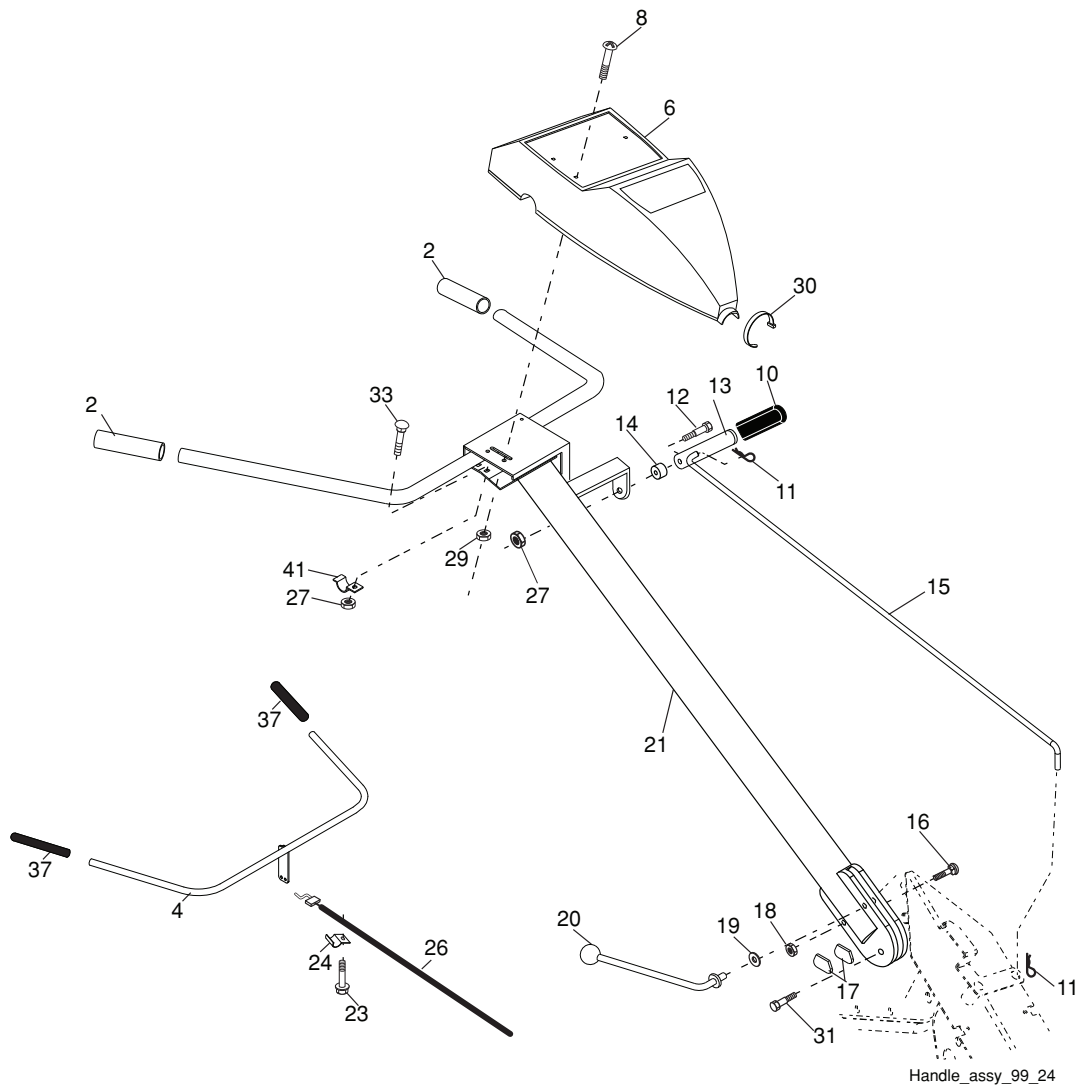

KEY NO.	PART NO.	DESCRIPTION
2	532 42 76-43	Grip, Handle
4	532 15 92-28	Bar Assembly, Control
6	532 18 06-85	Panel, Control
8	871 19 10-08	Screw, Truss Hd. #10-24 unc x 1/2
10	532 12 47-97	Grip, Handle
11	532 12 47-88	Clip, Hairpin
12	532 08 13-28	Bolt, Shoulder
13	532 18 74-97	Handle, Shift
14	532 10 93-13	Grommet, Rubber
15	532 10 93-37	Rod, Shift
16	872 11 06-08	Bolt, Carriage 3/8-16 x 1 Gr. 5
17	532 10 92-29	Lock, Handle
18	873 68 06-00	Nut, Crownlock 3/8-16 unc
19	819 13 16-11	Washer 13/32 x 1 x 11 Ga.
20	532 10 92-28	Lever, Lock, Handle
21	532 18 11-27	Handle

KEY NO.	PART NO.	DESCRIPTION
23	532 08 67-77	Screw, Hex Washer SLT#10-24 x .50
24	532 00 94-84	Clip
26	532 15 92-31	Cable, Clutch
27	873 90 04-00	Nut, Hex Flange 1/4-20 unc
29	873 73 10-00	Nut, Keps #10-24 unc
30	532 10 41-64	Tie, Cable
31	532 15 06-96	Bolt, Pivot
33	872 14 04-04	Bolt, Carriage 1/4-20 unc x 1/2
37	532 10 26-04	Grip, Bar, Control
41	532 10 27-44	Clamp, Bar, Control

NOTE: All component dimensions given in U.S. inches.
1 inch = 25.4 mm

REPAIR PARTS

TILLER - - MODEL NUMBER CRT900 (96093001700), PRODUCT NUMBER 960 93 00-17
 MAINFRAME, LEFT SIDE

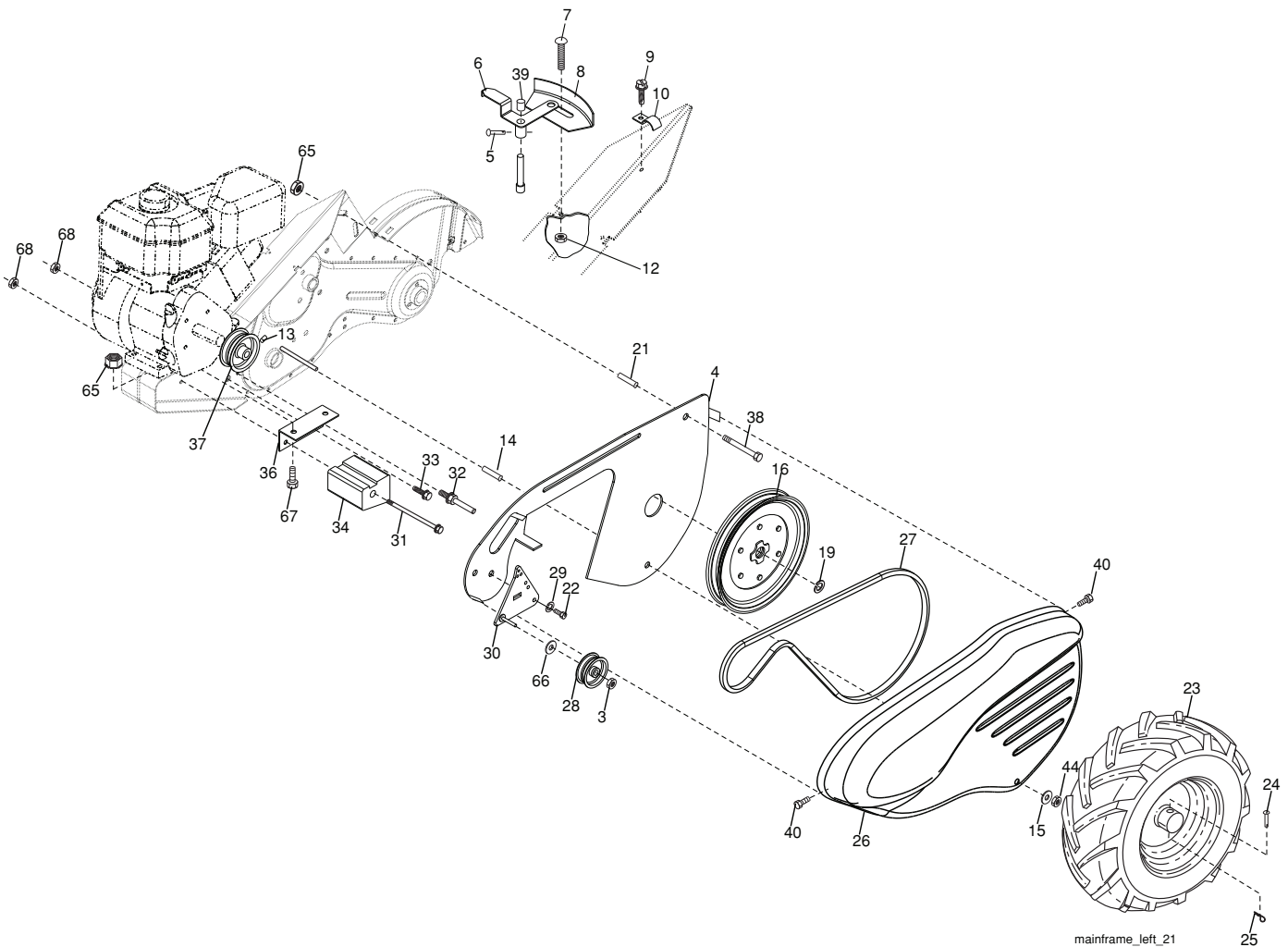

mainframe_left_21

KEY NO.	PART NO.	DESCRIPTION
3	873 22 06-00	Nut, Hex 3/8-16
4	532 17 01-27	Shield, Inner Belt Guard RT
5	532 16 43-29	Pin Spirol Flared
6	532 11 01-11	Lever, Shift
7	872 11 04-04	Bolt, Carriage 1/4-20 x 1/2 Gr. 5
8	532 00 87-00	Plate, Shift Indicator
9	532 08 67-77	Screw, Hex, Washer Head, Slotted #10-24 x 1/2
10	532 00 94-84	Clip
12	873 51 04-00	Nut, Keps Hex 1/4-20 unc
13	823 23 05-06	Screw, Set, Hex 5/16-18 x 3/8
14	532 11 06-52	Spacer, Split 0.327 x 0.42 x 2.09
15	819 11 11-16	Washer 11/32 x 11/16 x 16 Ga.
16	532 14 51-02	Sheave, Transmission
19	812 00 00-28	Retainer, Ring
21	532 15 61-17	Spacer, Split
22	874 77 05-08	Bolt, Fin Hex 5/16-24 unf x 1/2
23	532 10 21-90	Tire
	532 15 07-40	Rim
	532 12 47-18	Tire Valve
24	532 12 68-75	Rivet, Drilled
25	532 12 47-88	Clip, Hairpin

KEY NO.	PART NO.	DESCRIPTION
26	532 16 67-92	Guard, Belt
27	532 13 28-01	Belt, V
28	532 10 46-79	Pulley, Idler
29	812 00 00-32	Ring, Klip
30	532 15 92-29	Bracket, Idler
31	532 10 21-94	Bolt Fin Hex 3/8-16 unc x 10
32	532 10 21-41	Shaft, Idler Arm
33	874 76 06-16	Bolt, Hex 3/8-16 x 1
34	532 10 21-73	Counterweight
36	532 10 23-31	Bracket, Reinforcement, L. H.
37	532 13 08-12	Sheave, Engine
38	874 76 05-44	Bolt, Fin Hex 5/16-18 unc x 2-3/4
39	532 14 00-62	Cap, Plunger Blk
40	532 17 04-88	Screw Hex Wsh Slit #10-24 x 1/2
44	873 80 05-00	Nut Lock Hex w/Ins 5/16-18 unc PL
65	873 97 05-00	Nut Lock Hex Flange
66	819 13 13-12	Washer 13/32 x 13/16 x 12 Ga.
67	874 76 05-24	Bolt, Hex 5/16-18 x 1-1/2
68	873 51 06-00	Nut, Keps Hex 3/8-16 unc

NOTE: All component dimensions given in U.S. inches.
 1 inch = 25.4 mm

REPAIR PARTS

TILLER - - MODEL NUMBER CRT900 (96093001700), PRODUCT NUMBER 960 93 00-17
 MAINFRAME, RIGHT SIDE

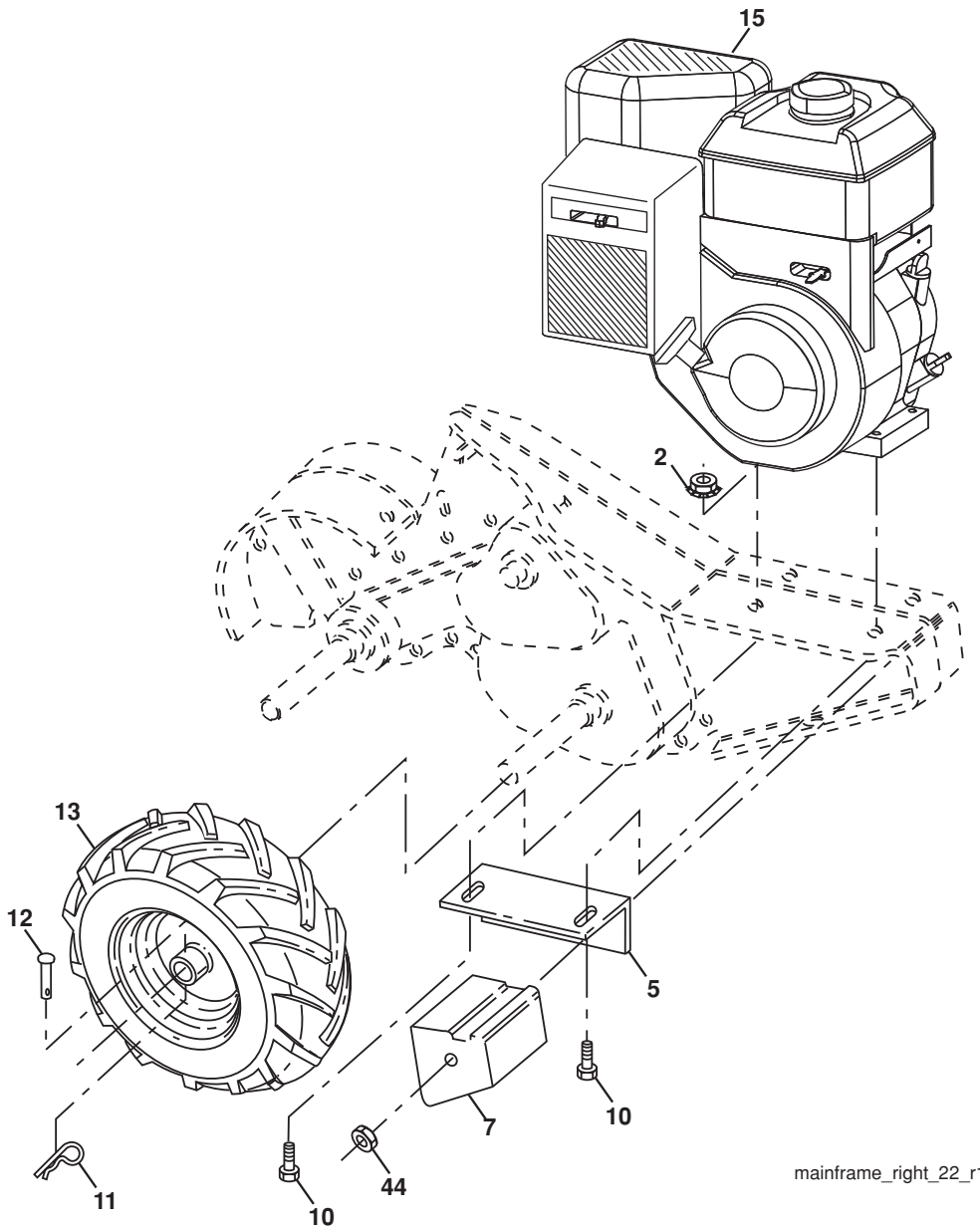

mainframe_right_22_r1

KEY NO.	PART NO.	DESCRIPTION
2	873 97 05-00	Locknut, Hex, Flange 5/16-18
5	532 10 23-32	Bracket, Reinforcement RH
7	532 10 21-73	Counter Weight
10	874 76 05-24	Bolt, Hex 5/16-18 x 1-1/2
11	532 12 47-88	Clip, Hairpin
12	532 12 68-75	Rivet, Drilled
13	532 10 21-90	Tire
	532 15 07-40	Rim
	532 12 47-18	Tire Valve

KEY NO.	PART NO.	DESCRIPTION
15	-----	Engine, Briggs & Stratton Model No. 12T202-1290-F8 (Order parts from Engine Manufacturer)
44	873 51 06-00	Nut, Keps Hex 3/8-16 unc

NOTE: All component dimensions given in U.S. inches
 1 inch = 25.4 mm
 For engine service and replacement parts, call the toll free number for your engine manufacturer listed below:
 Briggs & Stratton 1-800-233-3723

REPAIR PARTS

TILLER - - MODEL NUMBER CRT900 (96093001700), PRODUCT NUMBER 960 93 00-17
TRANSMISSION

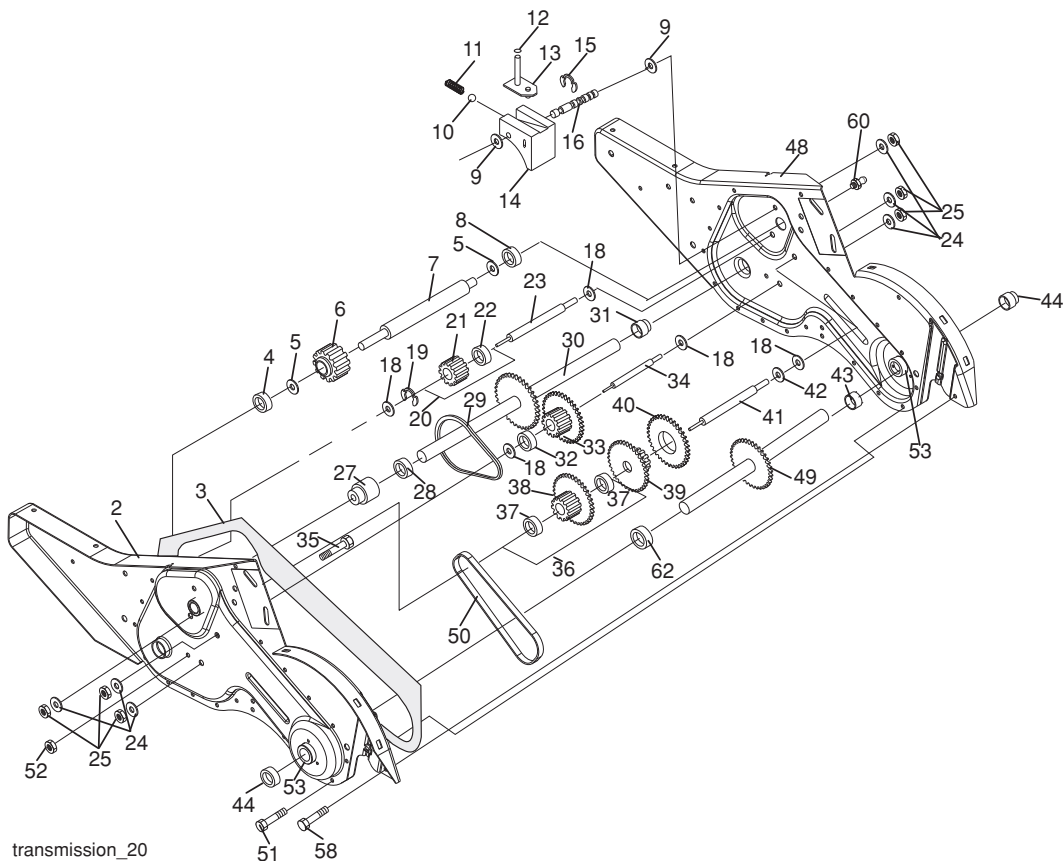

KEY NO.	PART NO.	DESCRIPTION
1	532 18 85-54	Transmission Assembly (Includes Key Nos. 2-53)
2	532 18 84-82	Gearcase, L.H. w/Bearing (Includes Key No. 4)
3	532 16 19-63	Gasket, Gearcase
4	532 00 50-20	Bearing, Needle
5	532 00 13-70	Washer, Thrust 5/8 x 1.10 x 1/32
6	532 13 73-35	Pinion, Input
7	532 14 51-01	Shaft, Input
8	532 12 47-92	Bearing, Needle
9	532 15 44-67	Washer, Seal
10	532 12 46-97	Ball, Steel
11	532 10 03-71	Spring, Shift, Fork
12	532 10 61-60	O-Ring
13	532 14 21-45	Arm, Shift
14	532 00 83-53	Fork, Shift
15	812 00 00-39	Ring, Klip
16	532 15 44-66	Shaft, Shift
18	532 00 43-58	Washer
19	812 00 00-40	Ring, Klip
20	532 10 21-14	Gear, Assembly, Reverse Idler (Includes Key Nos. 21 and 22)
21	532 10 21-15	Gear, Reverse Idler
22	532 00 68-03	Bearing, Needle
23	532 10 21-11	Shaft, Reverse Idler
24	810 04 07-00	Washer, Lock 7/16
25	873 61 07-00	Nut, Hex 7/16-20
27	532 14 30-09	Bearing, Shaft, Ground Drive L.H.
28	532 10 63-90	Spacer 0.765 x 1.125 x 1.23
29	532 10 21-34	Chain #35-50 Pitch

KEY NO.	PART NO.	DESCRIPTION
30	532 15 07-37	Ground Shaft Assembly
31	532 14 30-08	Bearing, Shaft, Ground Drive R.H.
32	532 10 63-88	Spacer 0.70 x 1.00 x 1.150
33	532 10 21-21	Sprocket and Gear Assembly
34	532 10 21-12	Shaft, Reduction (2nd)
35	532 10 21-01	Screw, Whiz, Lock 5/16-18 x 3-1/2
36	532 15 43-55	Sprocket Assembly w/Bearing (Includes Key Nos. 37 and 38)
37	532 12 47-91	Bearing, Needle
38	532 15 43-56	Sprocket, Tine
39	532 10 53-45	Gear, Cluster, Red 1st & 2nd
40	532 10 53-46	Gear, Reverse
41	532 00 83-58	Shaft, Reduction (1st)
42	532 00 42-20	Washer, Thrust
43	532 10 61-46	Spacer 1.01 x 1.75 x 0.760
44	532 15 52-36	Seal Asm, Oil
48	532 18 84-85	Gearcase, R.H. w/Bearing (Includes Key No. 8)
49	532 43 14-85	Shaft, Tine
50	532 10 61-47	Chain, Roller #50-50 Pitch
51	817 72 04-08	Screw 1/4-20 x 1/2
52	873 22 05-00	Nut, Hex 5/16-18
53	532 16 51-40	Kit, Bearing
58	532 17 95-20	Bolt Shoulder 1/4-20 unc x .875
60	532 18 32-26	Fitting Grease
62	532 43 10-15	Spacer
--	532 00 60-66	Grease, Plastilube #1

NOTE: All component dimensions given in U.S. inches.
1 inch = 25.4 mm

REPAIR PARTS

TILLER - - MODEL NUMBER CRT900 (96093001700), PRODUCT NUMBER 960 93 00-17
TINE SHIELD

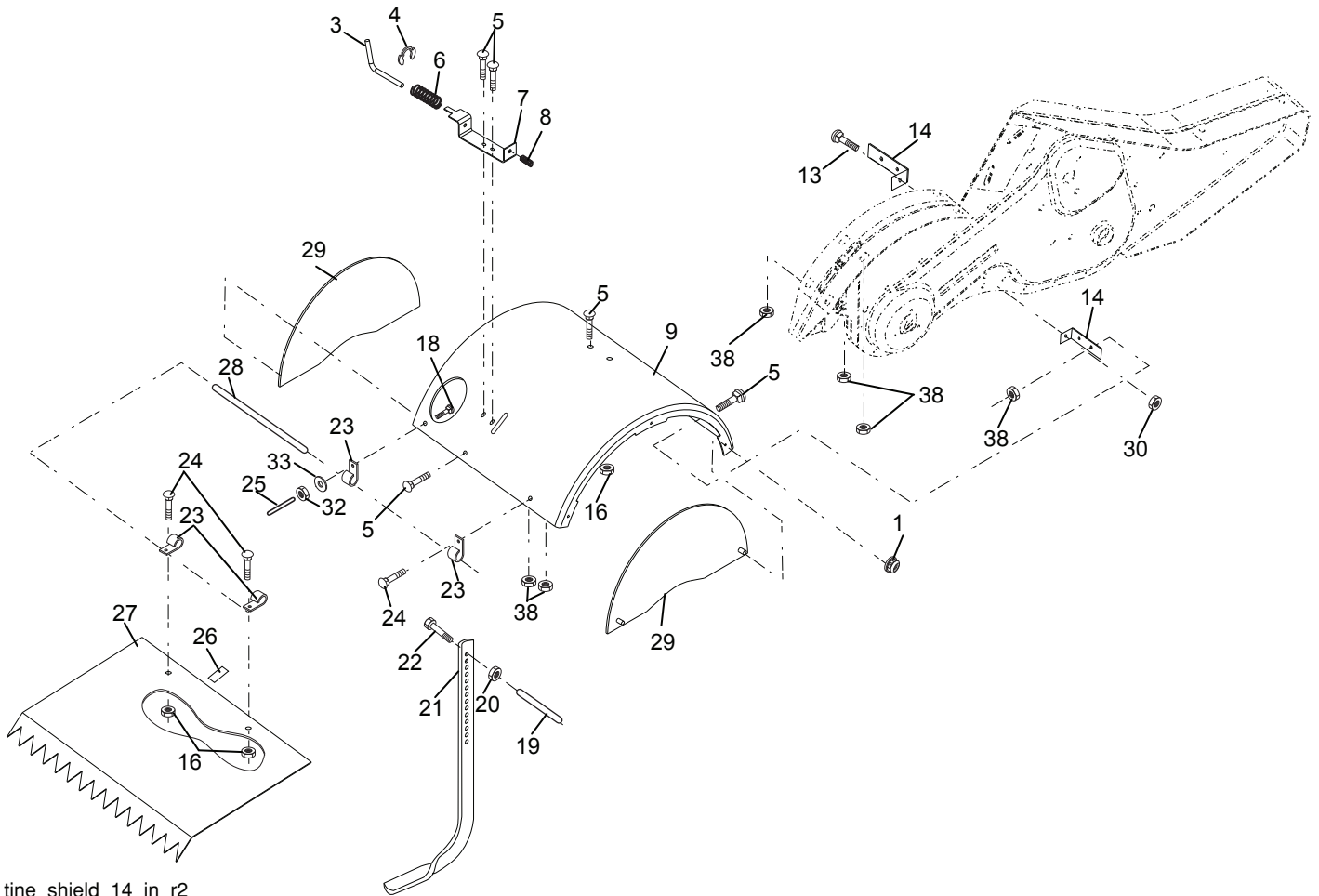

tine_shield_14_in_r2

KEY NO.	PART NO.	DESCRIPTION
1	873 90 05-00	Nut, Lock Hex Flange 5/16-18
3	532 00 83-93	Pin, Stake, Depth
4	812 00 00-35	Ring, Klip
5	532 18 08-47	Bolt, Rdhd Sqnk 5/16-18 x 3/4
6	532 00 83-94	Spring
7	532 00 83-92	Bracket, Latch
8	532 10 92-30	Spring, Depth Stake
9	532 13 88-63	Shield, Tine
13	872 11 05-10	Bolt, Carriage 5/16-18 x 1-1/4
14	532 12 43-43	Bracket, Shield Tine
16	873 90 04-00	Nut, Hex Flange 1/4-20 unc
18	872 04 04-10	Bolt, Carriage 1/4-20 x 1-1/4 Gr.
19	532 10 27-01	Grip
20	873 22 06-00	Nut, Hex 3/8-16
21	532 10 21-56	Stake, Depth
22	874 93 06-32	Bolt, Hex 3/8-16 x 2

KEY NO.	PART NO.	DESCRIPTION
23	532 00 44-40	Hinge
24	872 14 04-04	Bolt, Carriage 1/4-20 x 1/2 Gr. 5
25	532 12 47-17	Cap, Vinyl
26	532 10 92-27	Pad, Idler
27	532 12 54-51	Shield, Leveling
28	532 12 05-88	Pin, Hinge
29	532 40 39-60	Shield, Side
30	873 97 05-00	Nut Lock Hex Flange
32	873 22 04-00	Nut Fin Hex 1/4-20 unc
33	810 04 04-00	Washer Lock Hvy Helical 1/4
38	873 51 05-00	Nut, Keps Hex 5/16-18 unc

NOTE: All component dimensions given in U.S. inches.
1 inch = 25.4 mm

REPAIR PARTS

TILLER - - MODEL NUMBER CRT900 (96093001700), PRODUCT NUMBER 960 93 00-17
TINE ASSEMBLY

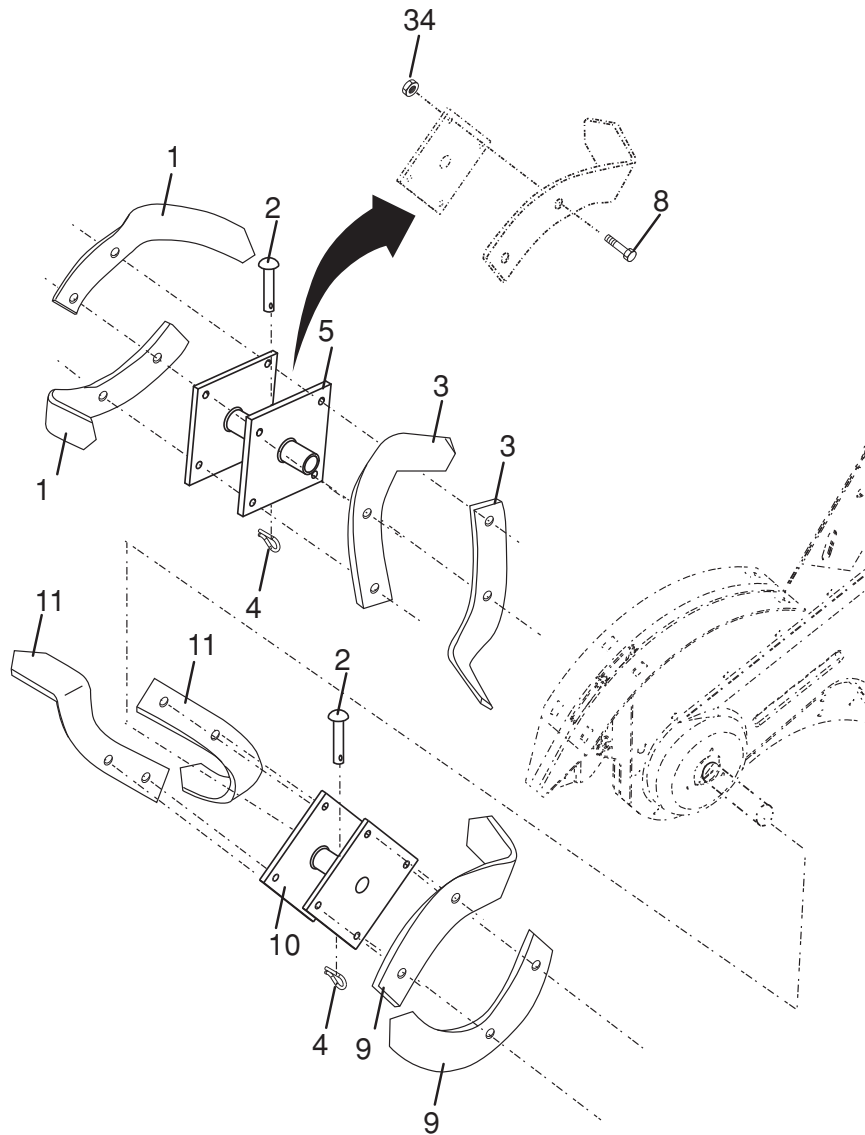

tine_ipb_99_2_r1

KEY NO.	PART NO.	DESCRIPTION
1	532 00 44-59	Tine, Outer, L.H.
2	532 13 26-73	Clevis Pin
3	532 00 65-54	Tine, Inner, L.H.
4	532 12 46-60	Retainer, Spring Zinc
5	532 13 27-21	Assembly, Hub and Plate, L.H.
8	874 61 06-16	Bolt, Hex 3/8-24 x 1
9	532 00 44-60	Tine, Outer, R.H.

KEY NO.	PART NO.	DESCRIPTION
10	532 13 27-22	Assembly, Hub and Plate, R.H.
11	532 00 65-55	Tine, Inner, R.H.
34	873 54 06-00	Nut Crownlock 3/8-24

NOTE: All component dimensions given in U.S. inches.
1 inch = 25.4 mm

REPAIR PARTS

TILLER - - MODEL NUMBER CRT900 (96093001700), PRODUCT NUMBER 960 93 00-17

DECALS

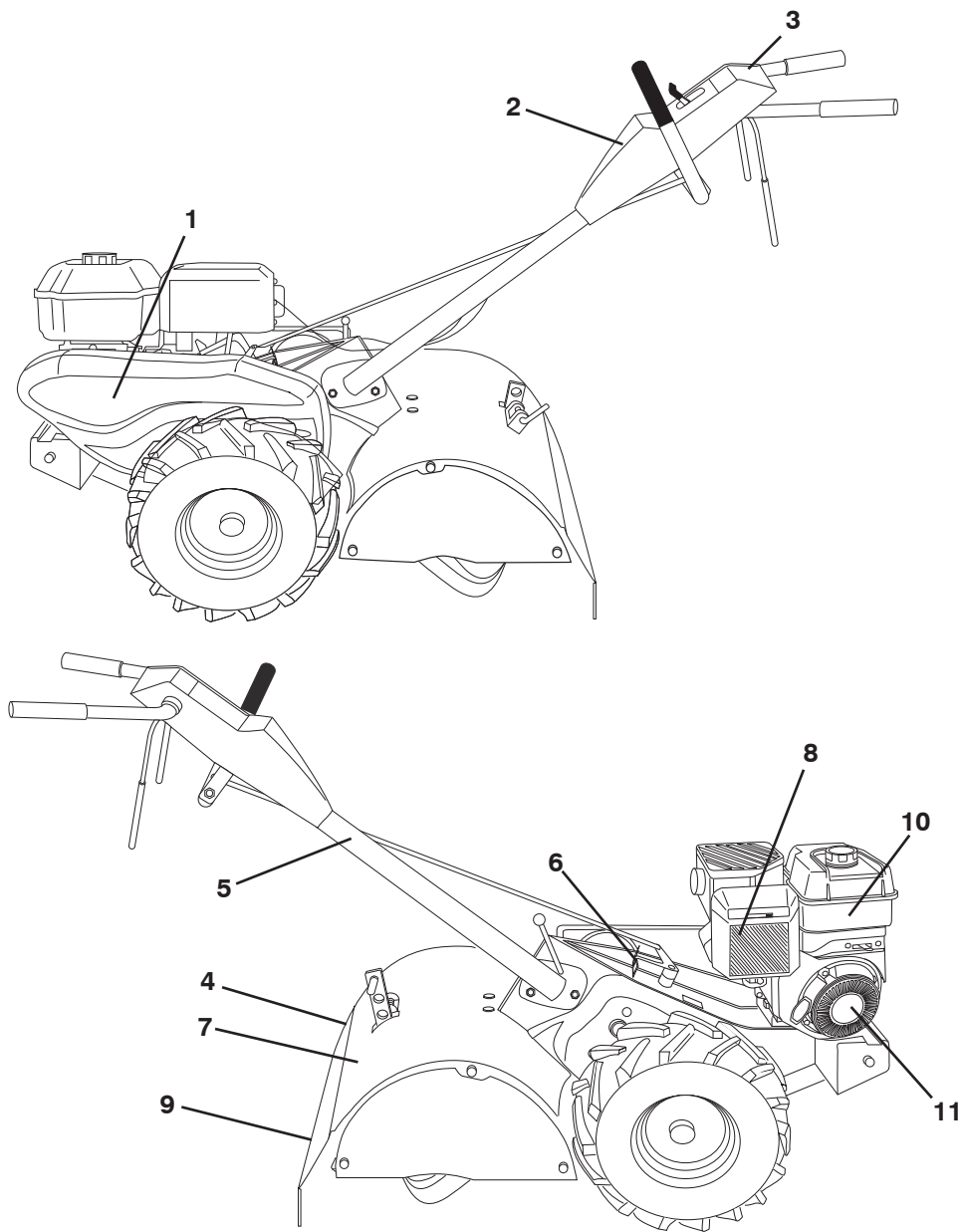

KEY NO.	PART NO.	DESCRIPTION
1	532 42 91-96	Decal, Belt Guard Badge
2	532 43 23-62	Decal, Husqvarna, Control Panel
3	532 43 14-62	Decal, Control Tine
4	532 42 83-28	Decal, Tine Shield
5	532 11 06-14	Decal, Hand Placement
6	532 10 21-80	Decal, Shift Indicator
7	532 42 29-72	Decal, Warning
8	532 40 91-40	Decal, Engine, 8.5
9	532 12 00-76	Decal, Warning, Rotating Tines
10	532 40 91-39	Decal, Engine, Fuel Tank, 8.5
11	532 41 18-16	Decal, Rewind Starter, B & S

SERVICE NOTES

WARRANTY STATEMENT

SECTION 1: LIMITED WARRANTY

Husqvarna Forest & Garden Company ("Husqvarna") warrants Husqvarna product to the original purchaser to be free from defects in material and workmanship from the date of purchase for the "Warranty Period" of the product as set forth below: **Lifetime Warranty (Parts and Labor):** All tiller lines and trimmer shafts against breakage. Proof of purchase required. **Lifetime Warranty ("PARTS ONLY" after initial warranty expiration):** Ignition coils and modules on handheld product. Proof of purchase required.

WARRANTY SCHEDULE FOR TURF CARE EQUIPMENT - Zero Turn Riders

(New warranty applies to units sold after August 1, 2005. Also applies to units factory-equipped with R.O.P.S.)

EZ Zero Turn Riders: 3 year consumer warranty or 600 hours of use (when used solely at the owner's residence.)

EZ & MZ Zero Turn Riders: 1 year commercial warranty or 600 hours of use.

IZ, LZ & BZ Zero Turn Riders: 5 year consumer warranty or 1,500 hours of use.

IZ, LZ & BZ Zero Turn Riders: 5 year commercial warranty or 1,500 hours of use.

3 Year or 1,500 Hour Commercial Use Warranty: spindles on zero turn riders, hydraulic pumps and wheel motors.

Warranty Schedule for Turf Care Walk Behind Units - W, WG & WH Zero Turn Riders - 3 year consumer and commercial

warranty. New warranty applies to units sold after August 1, 2005. Also applies to units factory-equipped with R.O.P.S.

2 Year COMMERCIAL and CONSUMER Warranty: all Husqvarna ground-engaging commercial equipment.

WARRANTY SCHEDULE FOR CONSUMER TURF CARE EQUIPMENT:

2 Year Consumer Warranty: Automatic mower, all Residential Zero Turn Riders, all lawn, yard and garden tractors, all noncommercial walk-behind mowers, tillers, snow blowers, electrical products and power-assist collection systems for noncommercial, non-professional, noninstitutional or nonincome producing use, except as herein stated. All consumer product use must have been limited to the owner's residence.

WARRANTY SCHEDULE FOR CONSUMER FOREST & GARDEN EQUIPMENT:

2 Year Consumer Warranty: all consumer chain saws, trimmers, brushcutters, clearing saws, handheld blowers, backpack blowers, hedge trimmers, and electrical products for noncommercial, non-professional, noninstitutional or nonincome producing use, except as herein stated. All consumer product use must have been limited to the owner's residence.

2 Year or 2,000 Hour Powertrain & 1 Year or 1,000 Hour Body Warranty: Husqvarna Utility Vehicles.

1 Year Warranty: Power cutters, stump grinder, pole pruners and pole saws for non-commercial, non-professional,

noninstitutional, non-municipality or non-income producing use. All 300 series trimmers, brushcutters, clearing saws,

hoeing trimmers, stick edgers, backpack blowers, hand held blowers, hedge trimmers, power-assist collection systems for

commercial, institutional, professional or income producing purposes or use.

1 Year Conditional Component Warranty: Chain saw crankshafts for commercial/professional use (parts and labor). Saw

must be operated with Husqvarna XP 2 cycle oil.

90 Day Commercial Warranty: Automatic mower, chain saws, 100 series trimmers, power cutters, stump grinders, pole saws, pole pruners, snow throwers, model series 580 & 600 walk-behind mowers, or any Husqvarna product used for commercial, institutional, professional, municipality or income producing purposes or use except as otherwise provided herein.

Batteries: 1 year prorated limited warranty with 100% replacement during the first 6 months.

Rental Warranty: 90 days on all applicable professional equipment reference warranty time period charts

located in the back of the Retailer Warranty Policy & Procedure Manual.

Husqvarna Safety Apparel carries a 90-day warranty from the date of the customer's original purchase for defects in

material and workmanship. Normal wear, tear or abuse is not covered under warranty. Product must be returned to Charlotte

with a warranty claim form. All care and maintenance instructions must be followed as stated by the manufacturer on the

care label. The fit of the protective apparel/boot is not covered under warranty.

30 Day Warranty: Replacement parts, accessories including bars and chains, tools and display items. Emission control

system components necessary to comply with CARB-TIER II and EPA regulations, except for those components which are

part of engine systems manufactured by third part engine manufacturers for which the purchaser has received a separate

warranty with product at time of purchase.

SECTION 2: HUSQVARNA'S OBLIGATIONS UNDER THE WARRANTY

Husqvarna will repair or replace defective components without charge for parts or labor if a component fails because of a defect in material or workmanship during the warranty period.

SECTION 3: ITEMS NOT COVERED BY THIS WARRANTY

The following items are not covered by this warranty:

(1) Normal customer maintenance items which become worn through normal regular use, including, but not limited to, belts, blades, blade adapters, bulbs, clutches, clutch drums, filters, guide bars, lubricants, rewind springs, saw chain, spark plugs,

starter ropes and tiller lines;

(2) Natural discoloration of material due to ultraviolet light;

(3) Engine and drive systems not manufactured by Husqvarna; these items are covered by the respective manufacturer's warranty as provided in writing with the product information supplied at the time of purchase; all claims must be sent to the appropriate manufacturer;

(4) Lawn and garden attachments are covered by a third party which gives a warranty, all claims for warranty should be sent to the manufacturer;

(5) Commercial or consumer mowing decks with sand abrasion damage.

(6) Emission Control System components necessary to comply with CARB-TIER II and EPA regulations which are manufactured by third party engine manufacturer.

SECTION 4: EXCEPTIONS AND LIMITATIONS

This warranty shall be inapplicable to defects resulting from the following:

(1) Accident, abuse, misuse, negligence and neglect, including stale fuel, dirt, abrasives, moisture, rust, corrosion, or any adverse reaction due to incorrect storage or use habits;

(2) Failure to operate or maintain the unit in accordance with the Owner's/Operator's manual or instruction sheet furnished by Husqvarna;

(3) Alterations or modifications that change the intended use of the product or affects the product's performance, operation, safety, or durability, or causes the product to fail to comply with any applicable laws; or

(4) Additional damage to parts or components due to continued use occurring after any of the above.

REPAIR OR REPLACEMENT AS PROVIDED UNDER THIS WARRANTY IS THE EXCLUSIVE REMEDY OF THE PURCHASER. HUSQVARNA SHALL NOT BE LIABLE FOR ANY INCIDENTAL OR CONSEQUENTIAL DAMAGES FOR BREACH OF ANY EXPRESS OR IMPLIED WARRANTY ON THESE PRODUCTS EXCEPT TO THE EXTENT PROHIBITED BY APPLICABLE LAW. ANY IMPLIED WARRANTY OF MERCHANTABILITY OR FITNESS FOR A PARTICULAR PURPOSE ON THESE PRODUCTS IS LIMITED IN DURATION TO THE WARRANTY PERIOD AS DEFINED IN THE LIMITED WARRANTY STATEMENT. HUSQVARNA RESERVES THE RIGHT TO CHANGE OR IMPROVE THE DESIGN OF THE PRODUCT WITHOUT NOTICE, AND DOES NOT ASSUME OBLIGATION TO UPDATE PREVIOUSLY MANUFACTURED PRODUCTS.

Some states do not allow the exclusion of incidental or consequential damages, or limitations on how long an implied warranty lasts, so the above limitations or exclusions may not apply to you. This warranty gives you specific legal rights, and you may also have other rights which vary from state to state.

SECTION 5: CUSTOMER RESPONSIBILITIES

The product must exhibit reasonable care, maintenance, operation, storage and general upkeep as written in the maintenance section of the Owner's/Operator's manual. Should an operational problem or failure occur, the product should not be used, but delivered as is to an authorized Husqvarna retailer for evaluation. Proof of purchase, as explained in section 6, rests solely with the customer.

SECTION 6: PROCEDURE TO OBTAIN WARRANTY CONSIDERATION

It is the Owner's and Retailer's responsibility to make certain that the Warranty Registration Card is properly filled out and mailed to Husqvarna Forest & Garden Company. This card should be mailed within ten (10) days from the date of purchase in order to confirm the warranty and to facilitate post-sale service.

Proof of purchase must be presented to the authorized Husqvarna retailer in order to obtain warranty service. This proof must include date purchased, model number, serial number, and complete name and address of the selling retailer.

To obtain the benefit of this warranty, the product believed to be defective must be delivered to an authorized Husqvarna retailer in a timely manner, no later than thirty (30) days from date of the operational problem or failure. The product must be delivered at the owner's expense. Downtime, pick-up and delivery charges are not covered by this warranty. An authorized Husqvarna retailer can be normally located through the "Yellow Pages" of the local telephone directory or by calling 1-800-HUSKY62 for a retailer in your area.

HUSQVARNA

7349 Statesville Road

Charlotte, NC 28269

2008