

# **DIXON<sup>®</sup>**

## **Operator Manual**

**SPDZTR 42 / 96665760I**  
**SPDZTR 46 / 96665780I**  
**SPDZTR 46 BF / 96665800I**  
**SPDZTR 54 / 96665820I**

**SPDZTR 42 BF / 96665770I**  
**SPDZTR 46 CA / 96665790I**  
**SPDZTR 48 / 96669860I**  
**SPDZTR 54 / 96665830I**  
**SPDZTR 54 BF / 96665840I**



Please read the operator's manual carefully and make sure you understand the instructions before using the machine.

**When this product is worn out and no longer used, it should be returned to the reseller or other party for recycling.**

**In order to implement improvements, specifications and designs can be altered without prior notification.**

**Note that no legal demands can be placed based on the information contained in these instructions.**

**Use only original parts for repairs. The use of other parts voids the warranty.**

**Do not modify or install non-standard equipment to the unit without consent from the manufacturer. Modifications to the unit may cause unsafe operations or damage the unit.**

# CONTENTS

---

INTRODUCTION .....	5	Mowing Tips .....	31
Driving and Transport on Public Roads .....	5	Stopping the Engine.....	32
Towing .....	5	Manual Transport.....	33
Operating .....	5	MAINTENANCE.....	34
Good Service .....	6	Maintenance Schedule .....	34
SYMBOLS AND DECALS .....	7	Battery .....	36
SAFETY .....	9	Safety System.....	37
Safety Instructions.....	9	Fuel Pump Air Filter .....	37
Personal Safety Equipment .....	11	Tire Pressures.....	38
Slope Operation .....	11	Parking Brake .....	38
Safe Handling of Gasoline .....	13	V-belts .....	39
General Maintenance .....	14	Deck Belt.....	39
Transport .....	16	Cutting Blades.....	40
CONTROLS.....	17	Blade replacement.....	40
Control Locations .....	17	Adjusting the Mower Deck .....	41
Steering Control Levers.....	18	Leveling deck.....	41
Parking Brake.....	19	Anti-scalp Rollers .....	42
Throttle Control .....	19	Caster Wheels .....	43
Blade Switch .....	19	Cleaning .....	43
Ignition Switch .....	20	Hardware.....	43
Choke Control .....	20	LUBRICATION.....	44
Fuses.....	20	Front Wheel Mount .....	45
Fuel Tank .....	21	Front Wheel Bearings.....	45
Fuel Shut Off Valve .....	22	Deck Spindles .....	45
Cutting Height Adjuster .....	22	Transmission.....	45
Seat Adjustment Lever .....	23	TROUBLESHOOTING .....	46
Hour Meter .....	23	STORAGE .....	48
OPERATION .....	24	Winter Storage.....	48
Training.....	24	Service .....	48
Steering .....	24	SCHEMATICS.....	49
Before Starting .....	25	TECHNICAL DATA .....	50
Starting the Engine.....	25	Accessories.....	56
Jumper Cables.....	28	Torque Specifications.....	56
Running .....	29	CONFORMITY CERTIFICATES.....	57
Operating On Hills.....	30	SERVICE JOURNAL.....	58



**WARNING!**

Failure to follow cautious operating practices can result in serious injury to the operator or other persons. The owner must understand these instructions, and must allow only trained persons who understand these instructions to operate the mower.

Each person operating the mower must be of sound mind and body and must not be under the influence of any mind altering substance.



**WARNING!**

Engine exhaust, some of its constituents, and certain vehicle components contain or emit chemicals known to the State of California to cause cancer and birth defects or other reproductive harm.



**WARNING!**

Battery posts, terminals and related accessories contain lead and lead compounds, chemicals known to the State of California to cause cancer and birth defects or other reproductive harm. Wash hands after handling.

# INTRODUCTION

---

## **Congratulations**

Thank you for purchasing a Dixon ride-on mower. This machine is built for superior efficiency to rapidly mow primarily large areas. A control panel easily accessible to the operator and a hydrostatic transmission regulated by steering controls both contribute to the machine's performance.

This manual is a valuable document. Read the contents carefully before using or servicing the machine. The following of instructions (use, service, maintenance) by all who operate this machine is important for the safety of the operator and others. It can also considerably increase the life span of the machine and increase its resale value.

If you sell your machine, be sure to give the operator's manual to the new owner.

The final chapter of this operator's manual provides a Service Journal. Ensure that service and repair work are documented. A well-kept service journal reduces service costs for the maintenance and affects the machine's resale value. Please contact your dealer for more information. Take the operator's manual along when the machine is taken to your dealer for service.

## **General**

In this operator's manual, left and right, backward and forward are used in relation to the machine's normal driving direction.

Continuous dedication to improve our products require that specifications and design are subject to change without notice.

## **Driving and Transport on Public Roads**

Check applicable road traffic regulations before transporting on public roads. If the machine is transported, you must always use approved fastening equipment and ensure that the machine is well anchored. DO NOT operate this machine on public roadways.

## **Towing**

If machine is equipped with a tow hitch, use extreme caution when towing. Never allow children or others in or on the towed equipment. Make wide turns to avoid jack-knifing. Travel slowly and allow extra distance to stop.

Do not tow on sloped ground. The weight of the towed equipment may cause loss of traction and loss of control.

Follow the manufacturer's recommendation for weight limits for towed equipment. Do not tow near ditches, canals, and other hazards.

## **Operating**

This machine is constructed only for mowing grass on lawns and even ground without obstacles such as stones, tree stumps, etc. The machine can also be used for other tasks when equipped with special accessories provided by the manufacturer. Operating instructions for the accessories are provided with delivery. All other types of uses are incorrect. The manufacturer's directions concerning operation, maintenance, and repairs must be carefully followed.

Lawn mowers and all power equipment, can be potentially dangerous if used improperly. Safety requires good judgement, careful use in accordance with these instructions and common sense.

The machine must only be operated, maintained, and repaired by persons familiar with the machine's special characteristics and who are also knowledgeable about the safety instructions. Use only approved repair parts to maintain this machine.

Accident prevention regulations, other general safety regulations, occupational safety rules, and traffic regulations must be followed without fail.

Unauthorized modifications to the design of the machine may absolve the manufacturer from liability for any resulting personal injury or property damage.

# INTRODUCTION

---

## Good Service

Dixon's products are sold only in specialized retail stores with complete service. This ensures that you as a customer receive only the best support and service. Before the product is delivered, the machine has, for example, been inspected and adjusted by your retailer. See the certificate in the Service Journal in this operator's manual.

When you need spare parts or support in service questions, warranty issues, etc., please consult the following professional:

This Parts Manual belongs to the machine with the manufacturing number:	Engine

## Manufacturing Number

*The machine's manufacturing number can be found on the printed plate affixed to the engine compartment.*

Stated on the plate, from the top are:

- The machine's type designation (I.D.).
- The manufacturer's type number (Model).
- The machine's serial number (Serial no.)

*Please have the type designation and serial number available when ordering spare parts.*

The engine's manufacturing number is stamped on one of the valve covers.

The plate states:

- The engine's model.
- The engine's type.
- Code

*Please have these available when ordering spare parts.*

The wheel motors and hydrostatic pumps have a barcode decal affixed at the rear.

# SYMBOLS AND DECALS

These symbols are found on the machine and in the operator's manual.

Study them carefully so that you know what they mean.

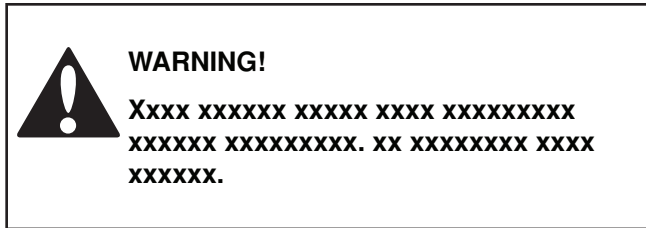

Used in this publication to notify the reader of a risk of personal injury or death, particularly if the reader should neglect to follow instructions given in the manual.

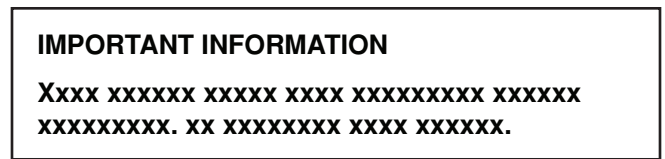

Used in this publication to notify the reader of a risk of material damage, particularly if the reader should neglect to follow instructions given in the manual. Used also when there is a potential for misuse or misassembly.



Reverse



Neutral



Fast



Slow



Choke

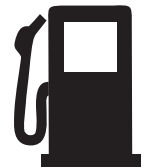

Fuel



Warning!



Parking Brake



CE conformity marking. Only for European market



Do not stand here,



Use protective glasses



Noise emissions to the surroundings in accordance with the European Union's directive. The machine's emission is stated in the chapter TECHNICAL DATA and on the decals.

Only machines for European market



Electromagnetic Compatibility (EMC) Compliance Australia and New Zealand only



Use protective gloves

# SYMBOLS AND DECALS

Read Operator's Manual

Shut off engine and remove key before performing any maintenance or repair work

Keep a safe distance from the machine

Use on slopes no greater than 10°

No passengers

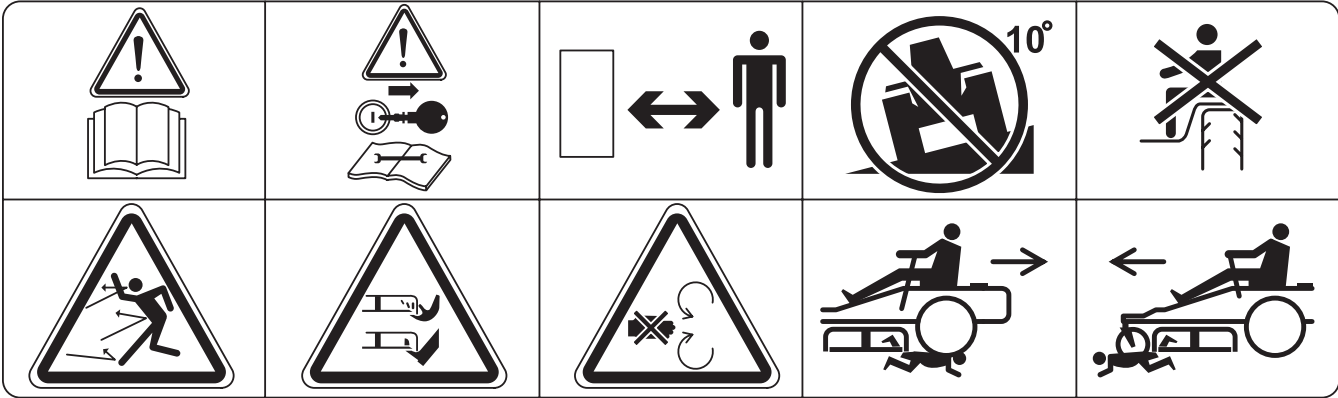

Whole body exposure to thrown objects

Severing of fingers and toes

Do not open or remove safety shields while engine is running

Careful backing up, watch for other people

Careful going forward, watch for other people



Moving sharp blades under cover



Battery acid is corrosive, explosive and flammable

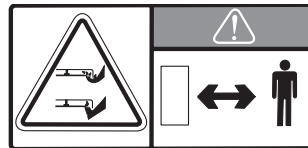

Warning! Rotating blades, keep away from the discharge deck

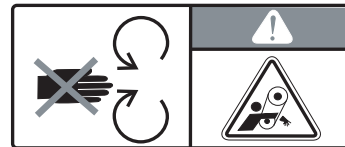

Do not touch parts



# SAFETY

## Safety Instructions

These instructions are for your safety. Read them carefully.



### WARNING!

**This symbol means that important safety instructions need to be emphasized. It concerns your safety.**

**IMPORTANT:** THIS CUTTING MACHINE IS CAPABLE OF AMPUTATING HANDS AND FEET AND THROWING OBJECTS. FAILURE TO OBSERVE THE FOLLOWING SAFETY INSTRUCTIONS COULD RESULT IN SERIOUS INJURY OR DEATH.

### General Operation

- Read, understand, and follow all instructions on the machine and in the manual before starting.
- Do not put hands or feet near rotating parts or under the machine. Keep clear of the discharge opening at all times.
- Only allow responsible adults, who are familiar with the instructions, to operate the machine.
- Clear the area of objects such as rocks, toys, wire, etc., which could be picked up and thrown by the blades.
- Be sure the area is clear of bystanders before operating. Stop machine if anyone enters the area.
- Never carry passengers. The machine is only intended for use by one person.
- Do not mow in reverse unless absolutely necessary. Always look down and behind before and while backing.
- Never direct discharged material toward anyone. Avoid discharging material against a wall or obstruction. Material may ricochet back toward the operator. Stop the blades when crossing gravel surfaces.
- Do not operate machine without the entire grass catcher, discharge guard, or other safety devices in place and working
- Slow down before turning.
- Never leave a running machine unattended. Always turn off blades, set parking brake, stop engine, and remove keys before dismounting.
- Disengage blades when not mowing. Shut off engine and wait for all parts to come to a complete stop before cleaning the machine, removing the grass catcher, or unclogging the discharge guard.
- Operate machine only in daylight or good artificial light.

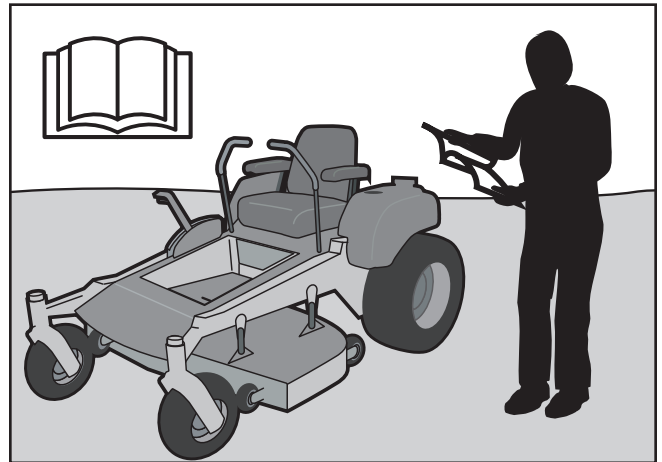

*Read the operator's manual before starting the machine*

8011-512

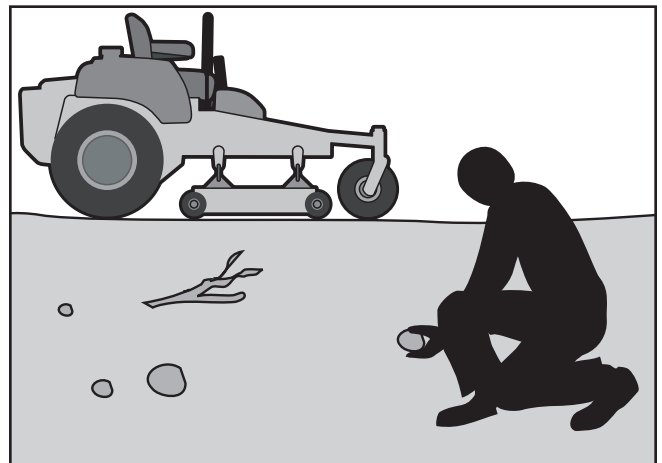

*Clear the area of objects before mowing*

8011-513

# SAFETY

- Do not operate the machine while under the influence of alcohol or drugs.
- Watch for traffic when operating near or crossing roadways.
- Use extra care when loading or unloading the machine into a trailer or truck.
- Always wear eye protection when operating machine.
- Data indicates that operators age 60 years and above are involved in a large percentage of riding mower-related injuries. These operators should evaluate their ability to operate the riding mower safely enough to protect themselves and others from serious injury.
- Follow the manufacturer's recommendation for wheel weights or counterweights.
- Anyone who operates this machine must first read and understand this Operation Manual. Local laws may regulate the age of the user.
- Keep machine free of grass, leaves or other debris buildup which can touch the hot exhaust or engine parts and burn. Do not allow the mower deck to plow leaves or other debris, causing buildup to occur.
- Clean any oil or fuel spillage before operating or storing the machine.
- Allow machine to cool before storage.

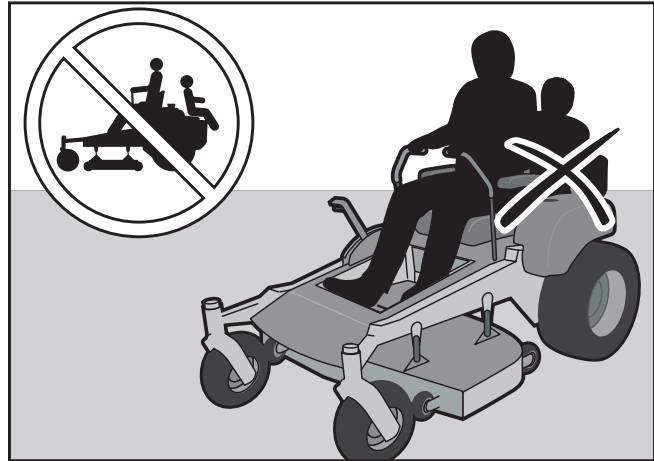

*Never take passengers*

8011-520



## **WARNING!**

**Engine exhaust and certain vehicle components contain or emit chemicals considered to cause cancer, birth defects, or other reproductive system damage. The engine exhaust contains carbon monoxide, which is a odorless, colorless, poisonous gas. Do not use the machine in enclosed spaces.**

# SAFETY

## Personal Safety Equipment



### WARNING!

When using the machine, approved personal protective equipment (shown in illustrations) shall be used. Personal protective equipment cannot eliminate the risk of injury but it will reduce the degree of injury if an accident does happen. Ask your retailer for help in choosing the right equipment.

- Make sure that you have first aid equipment close at hand when using the machine.
- Never use the machine when barefoot.
- Always wear protective shoes or boots, preferably with steel toe caps.
- Always wear approved protective glasses or a full visor when assembling or driving.
- Always wear gloves when handling the blades.
- Never wear loose clothing that can get caught in moving parts.
- Use ear protectors to avoid damage to hearing.

## Slope Operation

Slopes are a major factor related to loss of control and tip-over accidents, which can result in severe injury or death. Operation on all slopes requires extra caution. If you cannot back up the slope or if you feel uneasy on it, do not mow it.

- Mow up and down slopes (10 degrees maximum), not across.
- Watch for holes, ruts, bumps, rocks, or other hidden objects. Uneven terrain could overturn the machine. Tall grass can hide obstacles.
- Choose a low ground speed so that you will not have to stop while on the slope.
- Do not mow on wet grass. Tires may lose traction.
- Avoid starting, stopping, or turning on a slope. If the tires lose traction, disengage the blades and proceed slowly straight down the slope.
- Keep movement on the slopes slow and gradual. Do not make sudden changes in speed or direction, which could cause machine to roll over.
- Use extra care while operating machine with grass catchers or other attachments; they can affect the stability of the machine.
- Do not use on steep slopes.
- Do not try to stabilize the machine by putting a foot on the ground.
- Do not mow near drop-offs, ditches, or embankments. The machine could suddenly roll over if a wheel is over the edge or if the edge caves in.

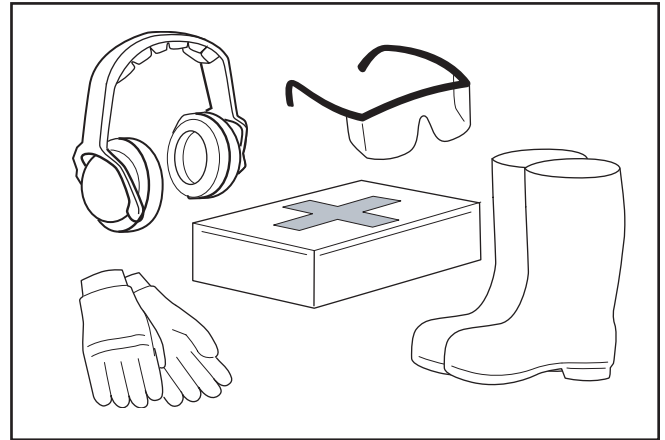

Personal protective equipment

8011-670a

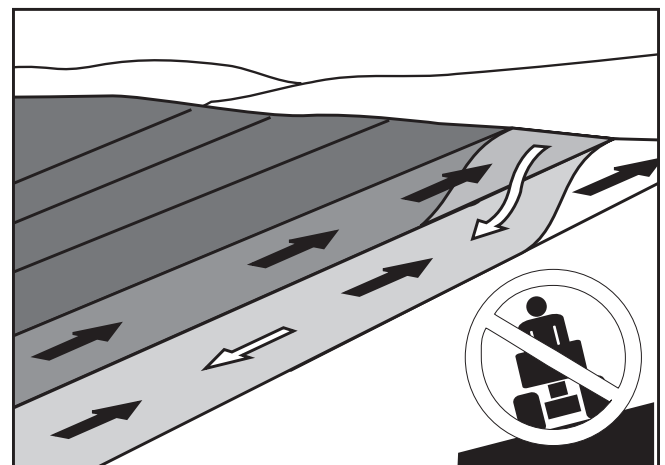

Mow up and down, not side to side

6003-004



### WARNING!

Do not drive up or down hills with slopes greater than 10 degrees. And do not drive across any slopes.

# SAFETY

## Children

Tragic accidents can occur if the operator is not alert to the presence of children. Children are often attracted to the machine and the mowing activity.

**Never** assume that children will remain where you last saw them.

- Keep children out of the mowing area and in the watchful care of a responsible adult other than the operator.
- Be alert and turn machine off if a child enters the area.
- Before and while backing, look behind and down for small children.
- Never carry children, even with the blades shut off. They may fall off and be seriously injured or interfere with safe machine operation. Children who have been given rides in the past may suddenly appear in the mowing area for another ride and be run over or backed over by the machine.
- Never allow children to operate the machine.
- Use extra care when approaching blind corners, shrubs, trees, or other objects that may block your view of a child.



8011-519

*Be extra cautious when driving on slopes*

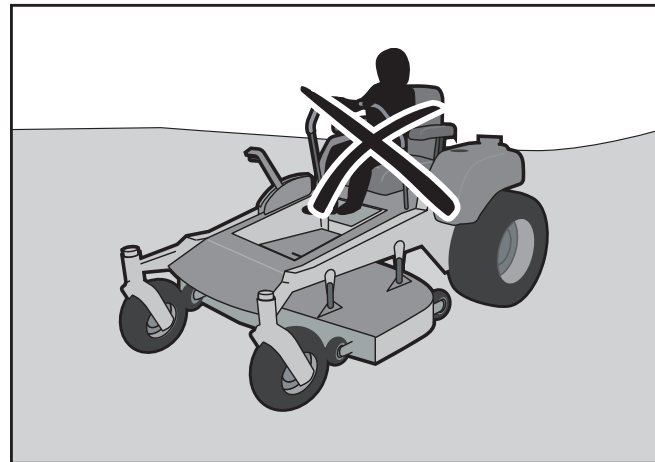

8011-517

*Never allow children to operate the machine*



8011-518

*Keep children away from work area*

# SAFETY



## WARNING!

**The engine must not be started when the driver's floor plate or any protective plate for the mower deck's drive belt is removed.**

## Safe Handling of Gasoline

To avoid personal injury or property damage, use extreme care in handling gasoline. Gasoline is extremely flammable and the vapors are explosive.

- Extinguish all cigarettes, cigars, pipes, and other sources of ignition.
- Use only approved gasoline containers.
- Never remove gas cap or add fuel with the engine running. Allow engine to cool before refueling.
- Never fuel the machine indoors.
- Never store the machine or fuel container where there is an open flame, spark, or pilot light such as on a water heater or other appliance.
- Before you begin refueling, minimize the risk of static electricity by touching a metal surface.
- Never fill containers inside a vehicle or on a truck or trailer bed with plastic liner. Always place containers on the ground away from the vehicle when filling.
- Remove gas-powered equipment from the truck or trailer and refuel it on the ground. If this is not possible, refuel such equipment with a portable container, rather than from a gasoline dispenser nozzle.
- Keep the nozzle in contact with the rim of the fuel tank or container opening at all times until fueling is complete. Do not use a nozzle lock-open device.
- If fuel is spilled on clothing, change clothing immediately.
- Never overfill fuel tank. Replace gas cap and tighten securely.
- Do not start the engine near spilled fuel.
- Never use gasoline as a cleaning agent.
- If leaks arise in fuel system, engine must not be started until problem has been resolved.
- Check the fuel level before each use and leave space for the fuel to expand, as the heat from the engine and the sun may otherwise cause the fuel to expand and overflow.



*Never fill the fuel tank indoors*

8011-516



## WARNING!

**The engine and the exhaust system become very hot during operation.**

**There is risk for burns if touched.**

**Allow engine and exhaust system to cool before refueling.**

# SAFETY

## General Maintenance

- Never operate machine in a closed area.
- Keep all nuts and bolts tight to be sure the equipment is in safe working condition.
- Never tamper with safety devices. Check their proper operation regularly.
- Keep machine free of grass, leaves, or other debris buildup. Clean oil or fuel spillage and remove any fuel-soaked debris. Allow machine to cool before storing.
- If you strike a foreign object, stop and inspect the machine. Repair, if necessary, before restarting.
- Never make any adjustments or repairs with the engine running.
- Check grass catcher components and the discharge guard frequently and replace with manufacturer's recommended parts, when necessary.
- Mower blades are sharp. Wrap the blade or wear gloves, and use extra caution when servicing them.
- Check brake operation frequently. Adjust and service as required.
- Maintain or replace safety and instruction labels, as necessary.
- Do not modify safety equipment. Check regularly to be sure it works properly. The machine must not be driven with defective or unmounted protective plates, protective cowlings, safety switches, or other protective devices.
- Do not change the settings of governors and avoid running the engine with overly high engine speeds. If you run the engine too fast, you risk damaging the machine components.
- Be very careful when handling battery acid. Acid on skin can cause serious corrosive burns. If you spill battery acid on your skin, rinse immediately with water.
- Acid in the eyes can cause blindness, contact a doctor immediately.
- Be careful when servicing the battery. Explosive gases form in the battery. Never perform maintenance on the battery when smoking or near open flames or sparks.
- The battery can explode and cause serious injury or damage.
- Ensure that nuts and bolts, especially the fastening bolts for the blade attachments, are properly tightened, torqued and that the equipment is in good condition.

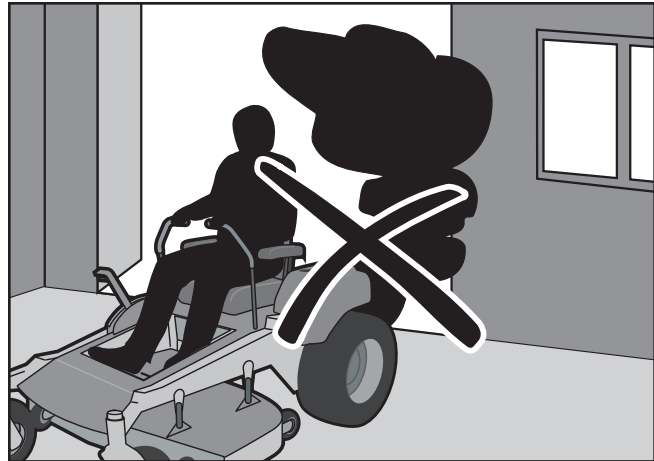

8011-515

*Never drive the machine in an enclosed space*



### **WARNING!**

**Use protective glasses for maintenance work.**



### **WARNING!**

**The battery contains lead and lead compounds, chemicals that are considered to cause cancer, birth defects, and other reproductive system damage. Wash your hands after handling the battery.**

# SAFETY

Sparking can occur when working with the battery and the heavy cables of the starter circuit. This can cause battery explosion, fire or eye injury. Sparking in this circuit can not occur after the chassis cable (normally negative, black) is removed from the battery.



## WARNING!

**Avoid electrical sparking and its consequences by the following routines:**

- Use protective goggles.
- Ensure that the fuel filler cap is mounted tightly and no flammable substances are stored in an open vessel.
- Never work with the starter circuit if there is spilled fuel.
- Disconnect the chassis cable from the battery first and reconnect it last.
- Do not make a bridge short circuit across the starter relay to run the starter.
- Never use the machine indoors or in spaces lacking proper ventilation. The exhaust fumes contain carbon monoxide, an odorless, poisonous, and lethal gas.
- Stop to inspect the equipment if you run over or into anything. If necessary, make repairs before starting.
- Never make adjustments with the engine running.
- The machine is tested and approved only with the equipment originally provided or recommended by the manufacturer. Only use approved repair parts for the machine.
- The blades are sharp and can cause cuts and gashes. Wrap the blades or use protective gloves when handling them.
- Check the parking brake's functionality regularly. Adjust and service as necessary.
- The mulch blades should only be used in familiar areas when higher quality mowing is desired.
- Reduce the risk of fire by removing grass, leaves, and other debris that may have accumulated on the machine.
- Allow the machine to cool before putting it in storage.



6003-009

*Do not smoke when performing maintenance on the battery. The battery can explode and cause serious injury/damage.*

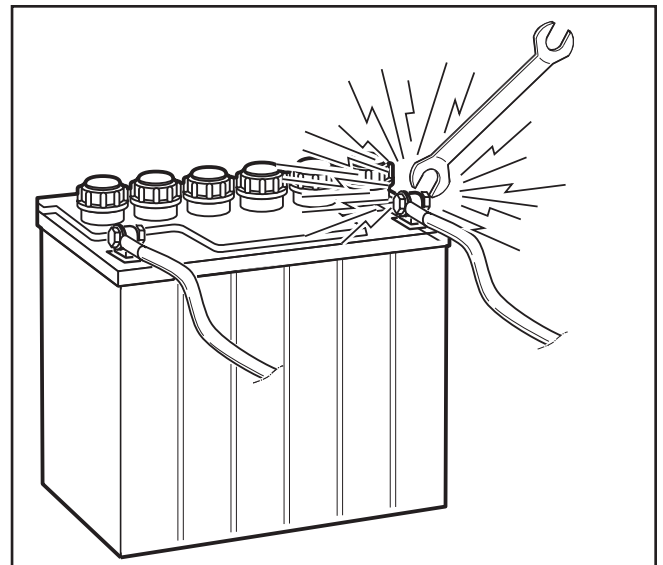

8009-728

*Risk of sparking*

# SAFETY

- Regularly clean deck and underside of deck, avoid spraying engine and electrical components with water.

## Transport

- The machine is heavy and can cause serious crushing injuries. Be extra cautious when it is loaded on or unloaded from a vehicle or trailer.
- Use an approved trailer to transport the machine. Activate the parking brake, turn off the fuel supply, and fasten the machine with approved fastening devices, such as bands, chains, or straps, when transporting.
- Do not operate this machine on public roadways.
- Check and abide by local traffic regulations before transporting the machine on any road.
- Do not tow this machine, it may cause damage to the drive system.

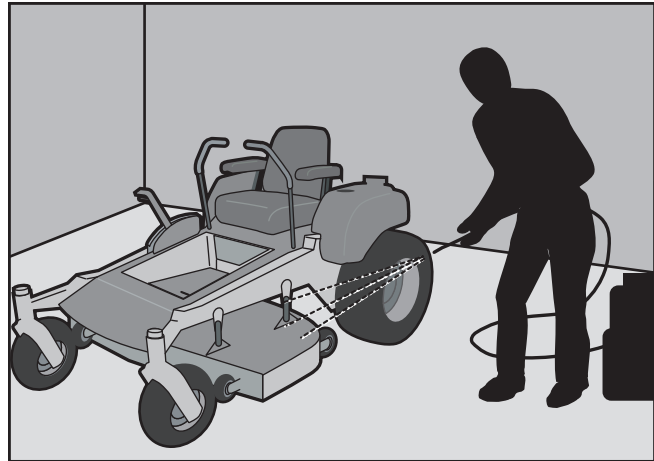

*Regularly clean deck*

8011-514

### IMPORTANT INFORMATION

**The parking brake is not sufficient to lock the machine in place during transport. Ensure that the machine is well fastened to the transport vehicle. Always reverse the machine onto the transport vehicle to avoid tipping it over.**

- Do not tow any trailers, etc. with this mower. They may jackknife or overturn causing damage to the mower and possibly serious injury to the operator.
- Load the unit onto truck or trailer by driving up ramps of suitable strength using a slow speed. Do not lift! The machine is not intended to be lifted by hand.



#### WARNING!

**Escaping hydraulic oil under pressure can have sufficient force to penetrate the skin, causing serious injury. If injured by escaping fluid, see a doctor at once. Serious infection or reaction can develop if proper medical treatment is not administered immediately.**



#### WARNING!

**This mower is equipped with an internal combustion engine and should not be used on or near any unimproved forested, bush covered or grassy lands unless the engine's system is equipped with a spark arrester meeting applicable local or state laws (if any). If a spark arrester is used, it should be maintained in effective working order by the operator.**



# CONTROLS

This operator's manual describes the Dixon Zero Turn Rider. The rider is fitted with either a Briggs & Stratton or Kawasaki four-stroke overhead valve engine.

Transmission from the engine is made via a belt-

driven hydraulic pumps. Using the left and right steering controls, the flow is regulated and thereby the direction and speed.

## Control Locations

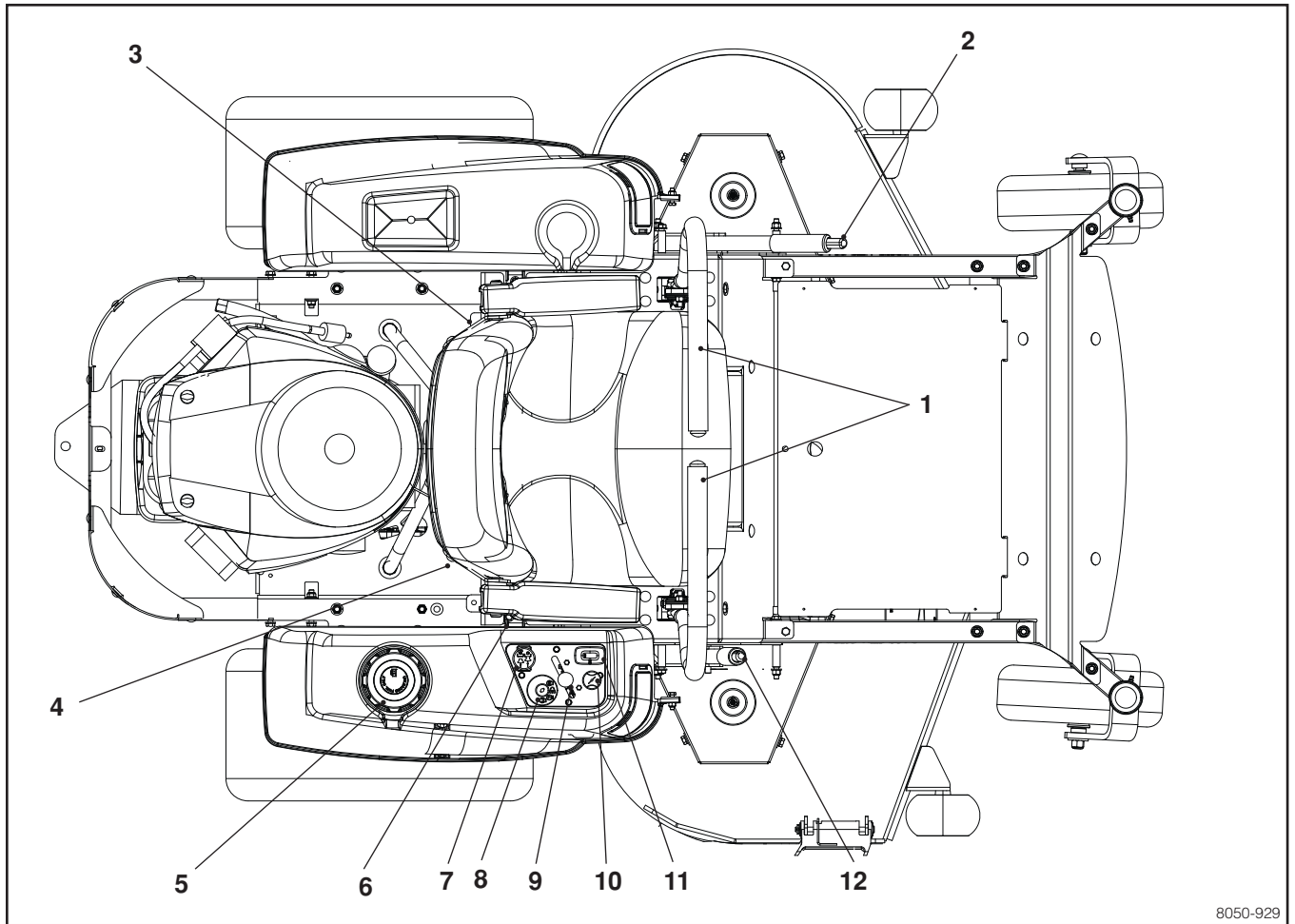

8050-929

- |                            |                     |
|----------------------------|---------------------|
| 1. Steering control levers | 8. Ignition switch  |
| 2. Parking brake           | 9. Throttle control |
| 3. Fuel shut off valve     | 10. Choke control   |
| 4. Fuses                   | 11. Hour meter      |
| 5. Fuel tank cap           | 12. Deck lift       |
| 6. Seat adjustment lever   |                     |
| 7. Blade switch            |                     |

# CONTROLS

## Steering Control Levers

The machine's speed and direction are continuously variable using the two steering controls. The steering controls can be moved forward or backward about a neutral position. Furthermore, there is a neutral position, which is locked if the steering controls are moved outward.

When both controls are in the neutral position (N), the machine stands still.

By moving both controls an equal amount forward or backward, the machine moves in a straight line forward or backward respectively.

In order, for example, to turn right while moving forward, move the right control towards the neutral position. The rotation of the right wheel is reduced and the machine turns to the right.

Zero turn can be achieved by moving one control backward (behind the neutral position) and carefully moving the other steering control forward from its neutral position. The rotation direction when zero turning is determined by which steering control is moved backward behind the neutral position. If the left steering control is pulled backward, the machine turns to the left. Use extra care when using this maneuver.

If the steering controls are in uneven positions when standing still or do not fit in the slots for moving the controls outward, they can be adjusted.

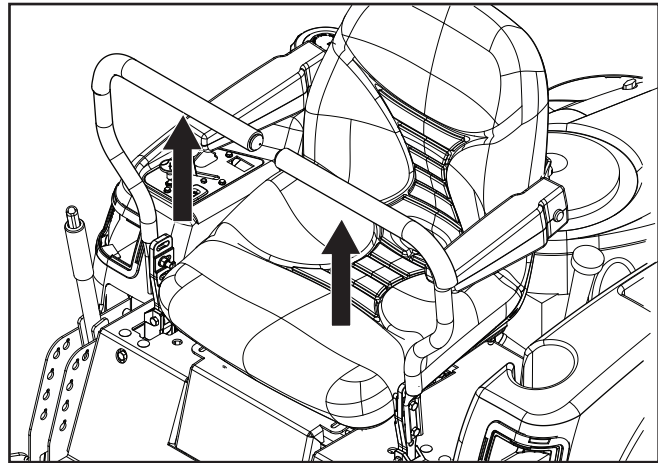

8058-022

*Steering controls*



### **WARNING!**

**The machine can turn very rapidly if one steering control is moved much further forward than the other.**

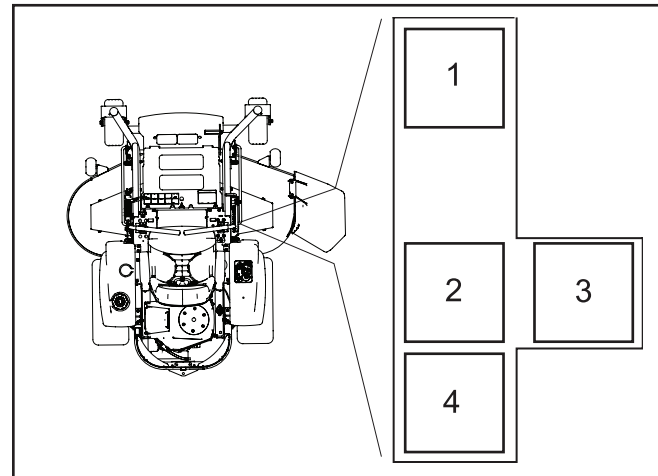

8011-7912a

1. Forward
2. Neutral
3. Neutral slot, Neutral lock
4. Reverse

*Motion control lever, right side*

# CONTROLS

## Parking Brake

### IMPORTANT INFORMATION

**The machine must stand absolutely still when applying the parking brake. Always set the parking brake before dismounting. Release the parking brake before moving the mower.**

The parking brake is found on the left of the machine. Push the release button and pull the lever backward to activate the brake—push forward to release it.

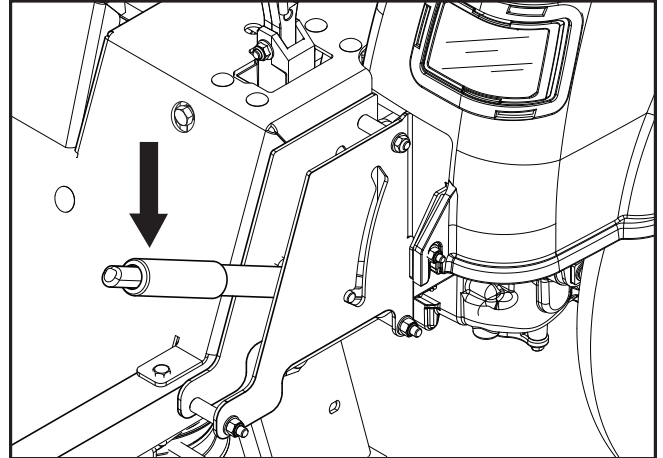

*Parking brake released*

8058-080

## Throttle Control

The throttle control regulates the engine speed and thereby the rate of rotation of the blades, assuming the blade switch is pulled out, see Engaging the Mower Deck.

In order to increase or decrease the engine speed, the control is moved forward or back respectively. Avoid idling the engine for long periods, as there is a risk of fouling the spark plugs.

USE FULL THROTTLE WHEN MOWING, for best mower performance and battery charging.

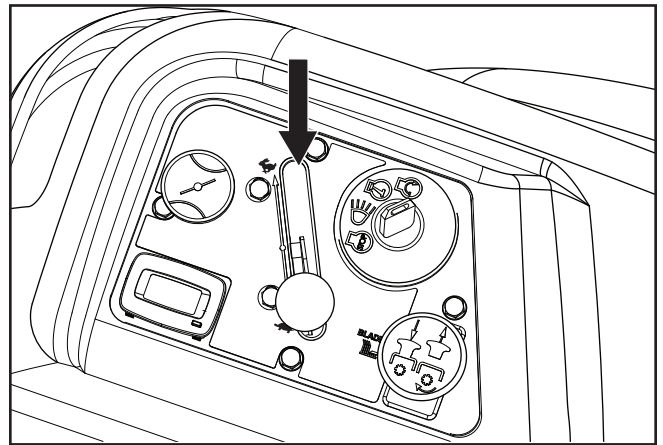

*Throttle control*

8058-134

## Blade Switch

In order to engage the mower deck, pull the knob out; the mower blades are disengaged when the knob is depressed.

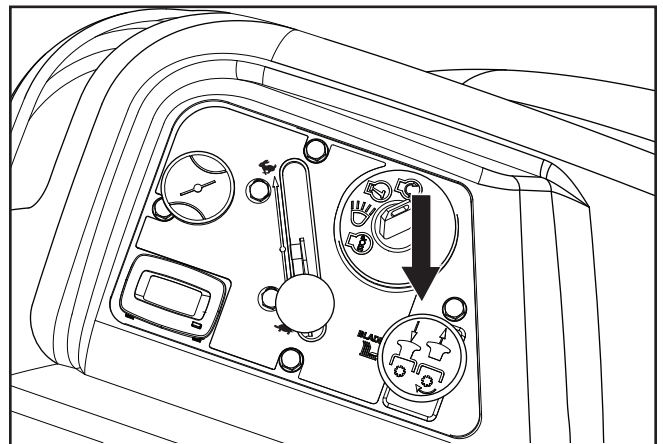

*Blade switch*

8058-134

# CONTROLS

## Ignition Switch

The ignition switch is placed on the control panel and is used to start and stop the engine.

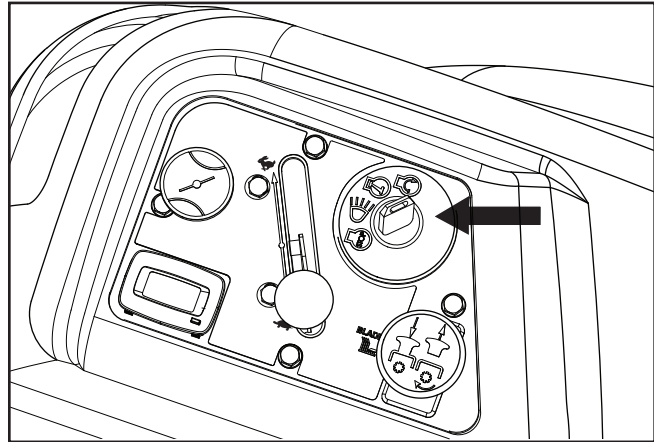

8058-134

*Ignition switch*

## Choke Control

The choke control is used for cold starts in order to provide the engine with a richer fuel mixture.

For cold starts on models with separate choke, the control on should be pulled out. Push the choke in once the engine starts.

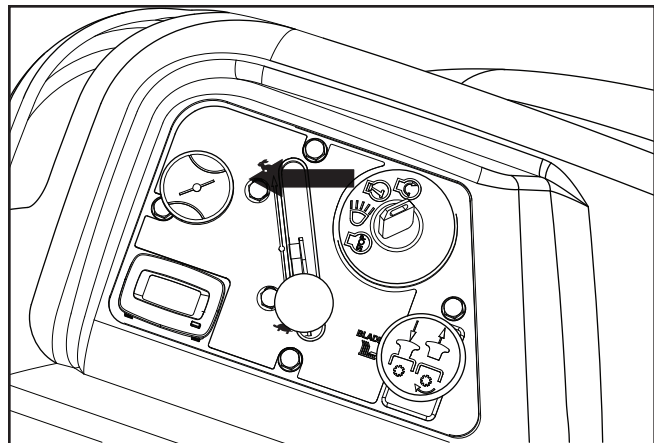

8058-134

*Choke control*

## Fuses

Fuses are located on the left hand side of the machine. They are accessed by tilting the seat forward. They are flat pin fuses of the same type used in automobiles.

There are two fuses with ratings and functions:

20 Amp Primary fuse

7.5 Amp Mower deck coupling

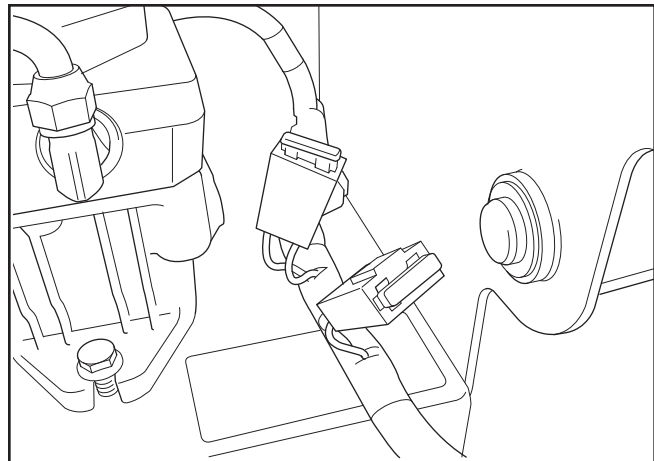

8011-420

*Fuses*

# CONTROLS

## Fuel Tank

Read the safety instructions before refueling. The machine has one fuel tank, just behind the console. The tank capacity is 3 gallons (11.4 liters).

Regularly check the gas cap gasket for damage and keep the cap properly tightened.

The engine will run on a minimum of 85-octane unleaded gasoline (no oil mix). Environmentally adapted alkylate gasoline can be used. See also Technical Data concerning ethanol fuel. Methanol fuel is not allowed. Do not use E85 alcohol based fuel. Damage to engine and components may occur.



### WARNING!

**Gasoline is highly flammable. Observe caution and fill the tank outdoors (see the safety instruction).**



### WARNING!

**The engine and the exhaust system, become very hot during operation.**

**Risk for burns if touched.**

**Allow engine and exhaust system to cool before refueling.**



### WARNING!

**Fill to bottom of filler neck. Do not overfill. Wipe off any spilled oil or fuel. Do not store, spill or use gasoline near an open flame.**

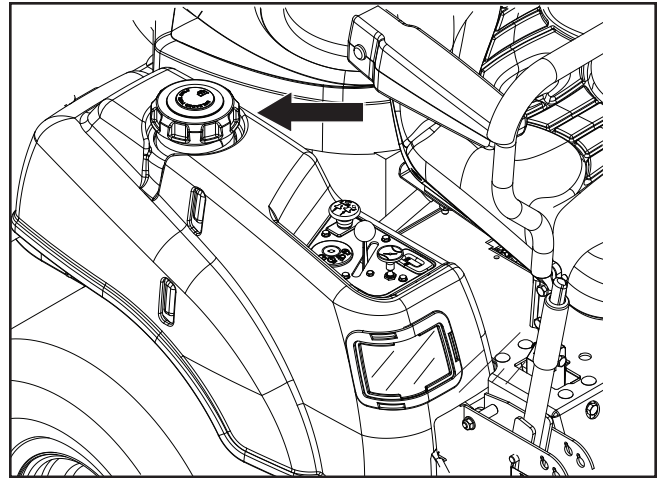

*Fuel tank*

8058-021

### IMPORTANT INFORMATION

Experience indicates that alcohol blended fuels (called gasohol, ethanol or methanol) can attract moisture which leads to separation and formation of acids during storage. Acidic gas can damage the fuel system of an engine while in storage. To avoid engine problems, the fuel system should be emptied before storage of 30 days or longer. Drain the gas tank, start the engine and let it run until the fuel lines and carburetor are empty. Use fresh fuel the next season. See Storage Instructions for additional information. Never use engine or carburetor cleaners in the fuel tank or permanent damage may occur.

When operating in temperatures below 32° F. (0° C.), use fresh, clean winter grade gasoline to insure good cold weather starting.

# CONTROLS

## Fuel Shut Off Valve

The fuel shut off valve is located at the left rear of the seat. The valve is off when the handle tab is turned perpendicular to the fuel line.

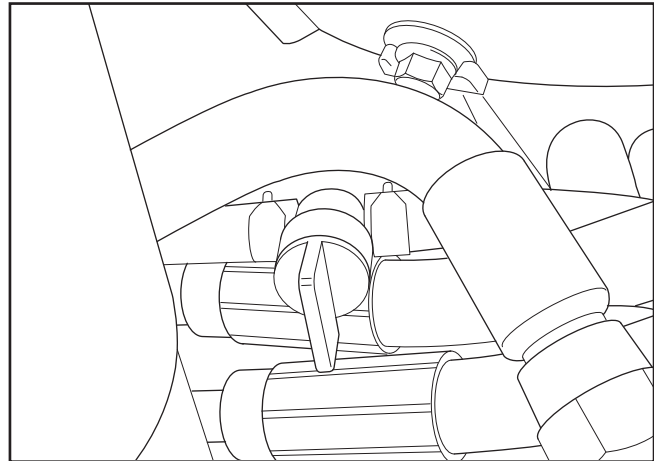

8011-419

*Fuel shut off valve in the CLOSED position*

### IMPORTANT INFORMATION

**Always raise the deck to the highest position for transport.**

## Cutting Height Adjuster

To set the desired deck cutting height, press the release button and move the lever forward to the correct cutting height on the cutting plate. The cutting height range is from 1½" (38mm) to 4" (102mm) in ½" (13mm) increments. The heights are measured from the ground up to the blade tip with the engine not running.

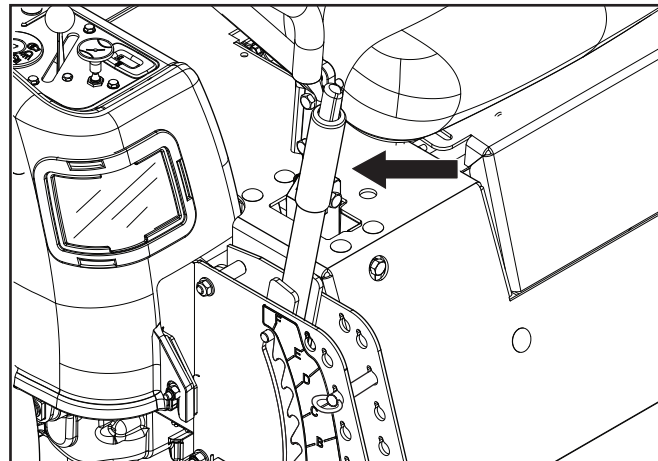

8058-019

*The mower deck's lifting lever*

### IMPORTANT INFORMATION

**In order to obtain an even cutting height, it is important that the air pressure in all tires is 15 psi / 103 kPa / 1 bar.**

# CONTROLS

## Seat Adjustment Lever

The seat can be adjusted lengthways. When making adjustments, the lever under the right side of the seat is pulled up, after which the seat can be moved backward or forward.

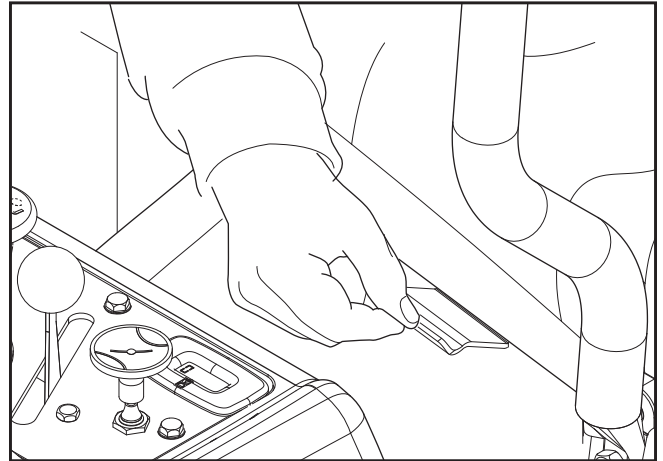

8058-023

*Lengthways adjustment*

## Hour Meter

The hour meter displays the total operating time. It will flash CHG OIL (Change Oil) at 50 hour intervals. The flash duration is one hour before and one hour after the interval. The CHG OIL icon will come on and shut off automatically. The hour meter cannot be manually reset.

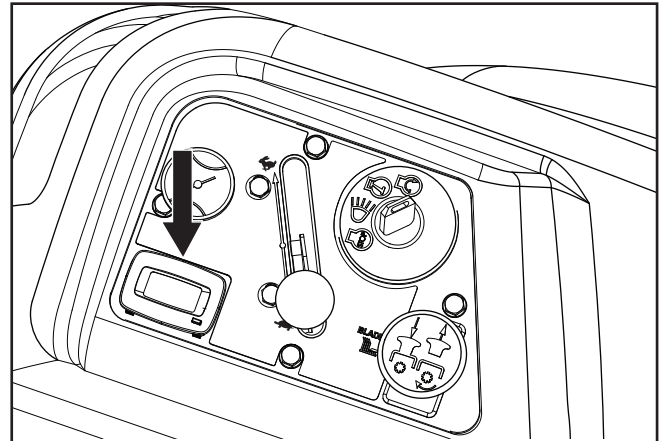

8058-134

*Hour meter*

# OPERATION

---

Read the **Safety** section and following pages, if you are unfamiliar with the machine.

## Training

Due to unique steering capabilities, zero turn mowers are far more maneuverable than typical riding mowers.

This section should be reviewed in its entirety prior to attempting to move the mower under its own power. When first operating the mower or until becoming comfortable with controls, use a reduced throttle speed and reduced ground speed. DO NOT move control levers to the furthest forward or reverse positions during initial operation.

First time users should become familiar with the mower's movement on a hard surface, such as concrete or blacktop PRIOR to attempting to operate on turf. Until the operator becomes comfortable with the mower controls and zero turning capability, overly aggressive maneuvers may damage turf.

### **IMPORTANT INFORMATION**

**When control levers are in the reverse position they return to neutral when released. This may cause the mower to suddenly stop.**

## Steering

### **To move forward and backward**

The direction and speed of the mower's movements are effected by the movement of the control lever(s) on each side of mower. The left control lever controls the left wheel. The right control lever controls the right wheel.

First time users should push the mower (see **Manual Transport** in the **Operation** section) to an open, flat area without other people, vehicles or obstacles nearby. To move the unit under its own power, the operator must sit in the seat and start the engine (see **Before Starting** in the **Operation** section). Adjust the engine speed to idle, disengage the parking brake but do not engage the blades at this time. Rotate control levers inward. As long as the control levers have not been moved forward or backwards, the mower will not move.

Slowly move both control levers forward slightly. This will allow mower to start moving forward in a straight line. Pull the control levers back to the neutral position and the mower should stop moving.

Pull back slightly on control levers, allowing the mower to move backwards. Push the control levers forward to the neutral position and mower should stop moving.

### **To turn to the right**

While moving in a forward direction, pull the right lever back towards the neutral position while maintaining the position of the left lever, this will slow the rotation of the right wheel and cause the machine to turn in that direction.

### **To turn to the left**

While moving in a forward direction pull the left lever back towards the neutral position while maintaining the position of the right lever, this will slow the rotation of the left wheel and cause the machine to turn in that direction.

### **To zero turn**

While moving in a forward direction, first pull both control levers back until the mower stops or slows dramatically.



# OPERATION

Then by alternating one lever slightly to the forward position and the other in the reverse position.

## Before Starting

- Read the sections Safety Instructions and Controls before starting the machine.
- Perform the daily maintenance before starting (see Maintenance Schedule in the Maintenance section).
- Check that there is sufficient fuel in the fuel tank.
- Adjust the seat to the desired position.

The following conditions must be fulfilled before the engine can be started:

- The blade switch for engaging the mower blades must be depressed.
- The parking brake must be on.
- Both steering controls must be in the locked (outer) neutral position.

## Starting the Engine

- Sit on the seat.
- Raise the mower deck by pushing the release button on the top of the lifting lever. Pull the lifting lever backward to the locked (transport) position.
- Activate the parking brake by pushing the release button in and pulling the lever fully upwards.

Disengage the mower blades by pressing the blade switch downwards.

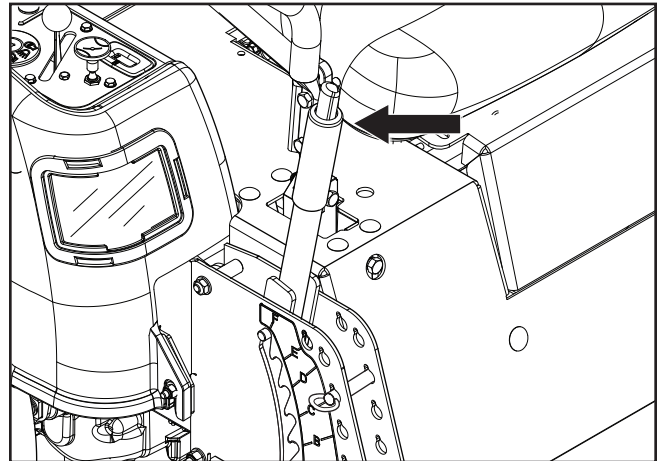

8058-019

*Mower deck lifting lever*

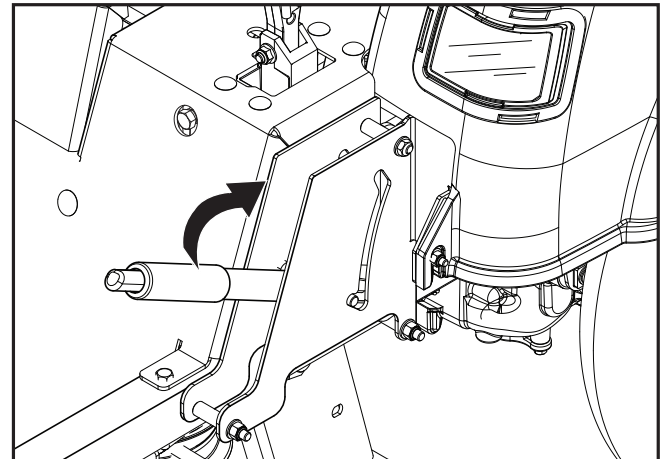

8058-080

*Pull parking brake upwards to activate.*

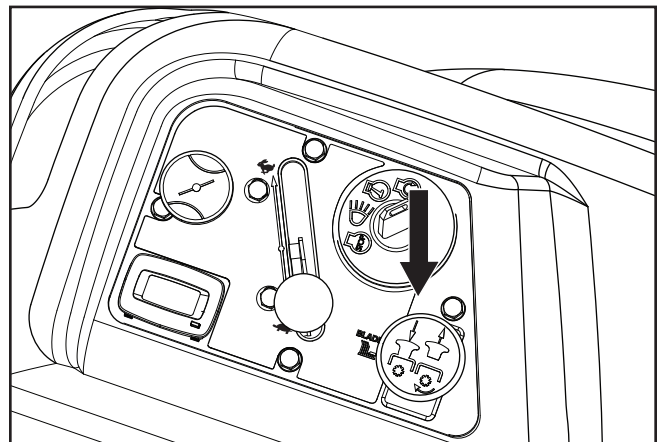

8058-134

*Blade switch*

# OPERATION

Move the steering controls outward to the locked (outer) neutral position.

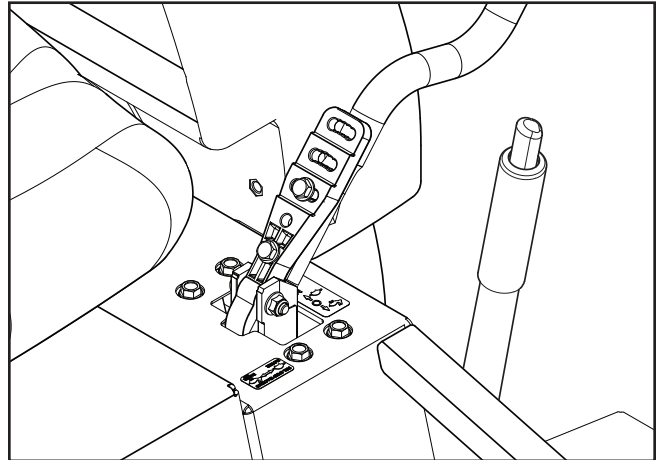

8058-077

*Place controls in neutral position*

Move the throttle to the middle position.

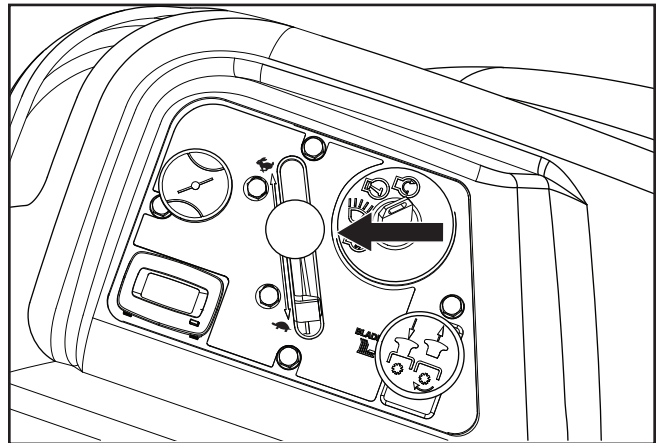

8058-148

*Set the throttle*

If the engine is cold, the choke control should be pulled up.

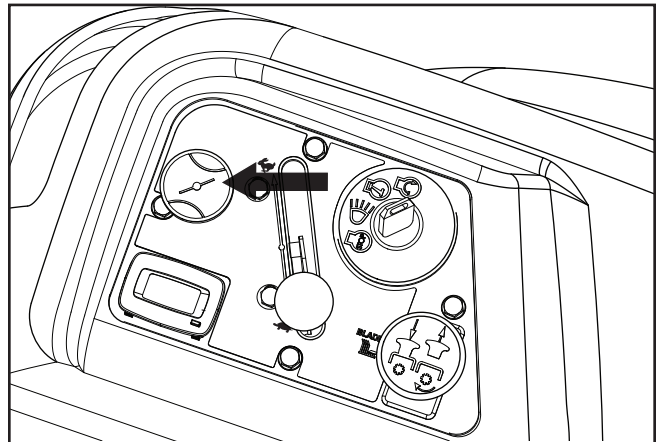

8058-134

*Set the choke control*

# OPERATION

Press in and turn the ignition key to the start position.

## IMPORTANT INFORMATION

**Do not run the starter for more than 5 seconds each time. If the engine does not start, wait approximately 10 seconds before retrying.**

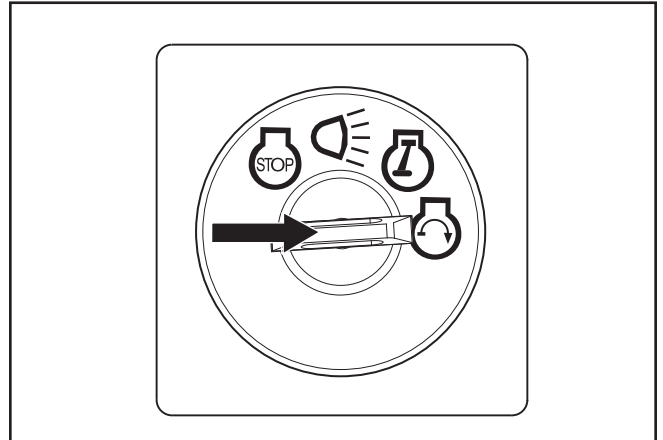

8050-780

*Turn to the start position*

When the engine starts, immediately release the ignition key back to the run position.



## WARNING!

**Engine exhaust and certain vehicle components contain or emit chemicals considered to cause cancer, birth defects or other reproductive system damage. The engine exhaust contains carbon monoxide, which is a odorless, colorless, poisonous gas. Do not use the machine in enclosed spaces.**

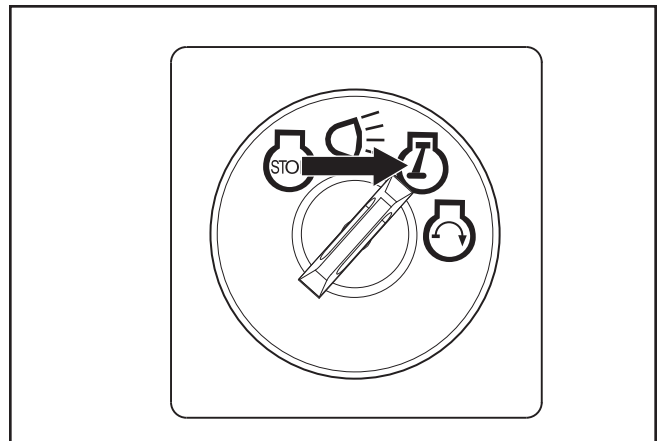

8050-781

*Return to run position*

Set the desired engine speed with the throttle. Allow the engine to run at a moderate speed, "half throttle" for 3-5 minutes before loading it too heavily. **USE FULL THROTTLE WHEN MOWING** (no choke).

If your battery is too weak to start the engine, it should be recharged. (See "Battery" in the Maintenance Section.)

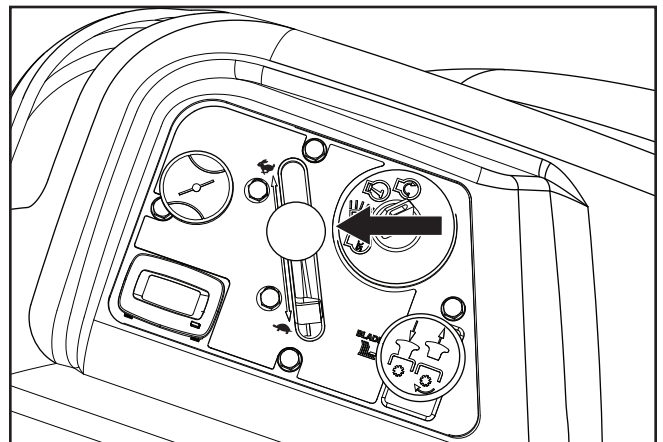

8058-148

*Set the engine speed*

# OPERATION

## Weak Battery



### WARNING!

Lead-acid batteries generate explosive gases. Keep sparks, flame and smoking materials away from batteries. Always wear eye protection when around batteries.



### IMPORTANT INFORMATION

Your mower is equipped with a 12-volt negative grounded system. The other vehicle must also be a 12-volt negative grounded system. Do not use your mower to start other vehicles.

If “jumper cables” are used for emergency starting, follow this procedure:

### Jumper Cables

- Connect each end of the RED cable to the POSITIVE (+) terminal on each battery, taking care not to short against chassis.
- Connect one end of the BLACK cable to the NEGATIVE (-) terminal of the fully charged battery.
- Connect the other end of the BLACK cable to a good CHASSIS GROUND on the mower with the discharged battery, away from the fuel tank and battery.

### To remove cables, reverse order

- Remove BLACK cable first from chassis and then from the fully charged battery.
- Remove RED cable last from both batteries.

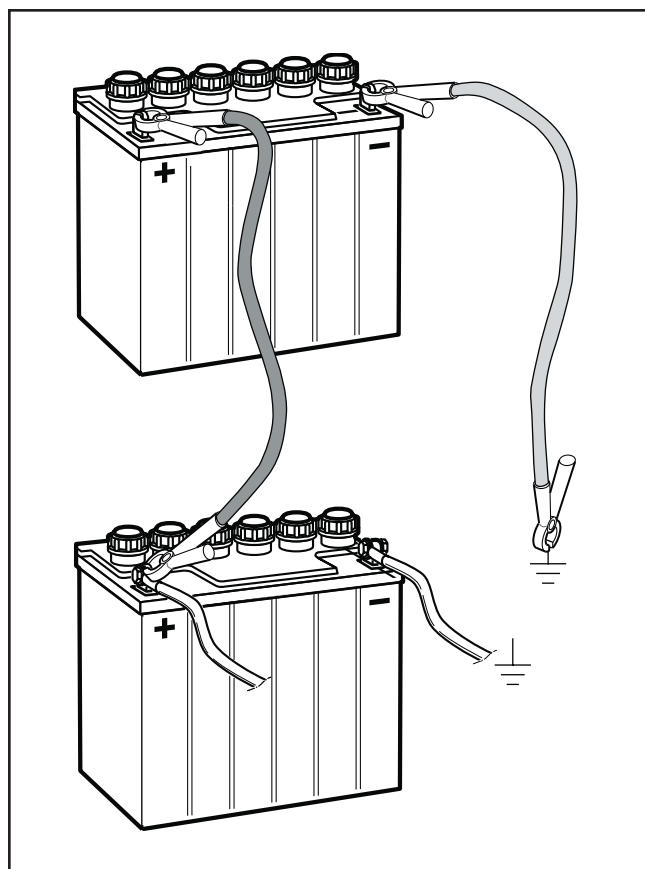

*Jumper cable connection*

8011-642

# OPERATION

## Running

1. Release the parking brake by pushing the top release button in and moving the lever downward.  
NOTE: The mower is equipped with an operator presence system. When the engine is running, any attempt by the operator to leave the seat without first setting the parking brake will shut off the engine.
2. Move the steering controls to the neutral position (N).

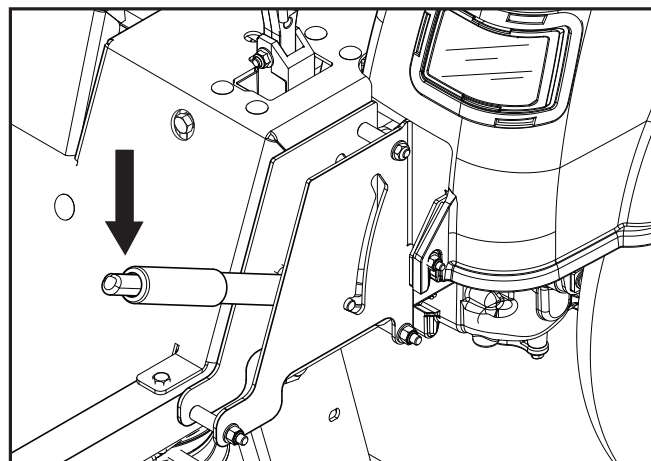

*Parking brake released*

8058-080

3. Set retaining pin into selected cutting height and secure the opposite side with a cotter hairpin.



### **WARNING!**

**Ensure that no one is near mower when engaging blade switch.**

**Make sure the work area is free from objects that could be thrown by the rotating blades.**

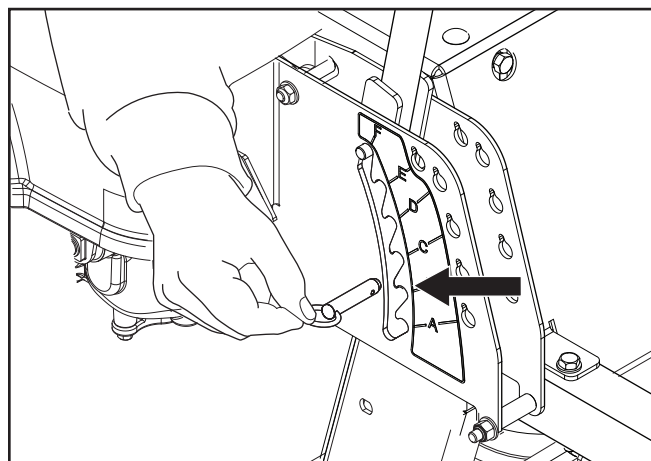

*Secure selected cutting height*

8058-024

4. Push the release button on the cutting height lever and move lever to the pin, release the button.
5. Set the cutting height with the cutting height adjustment lever.

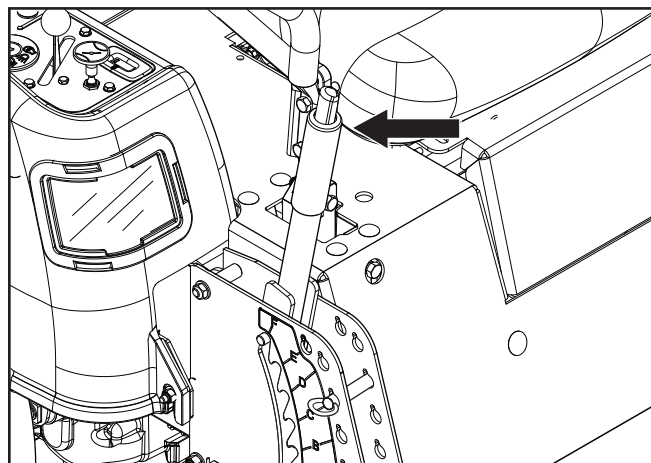

*Mower deck lifting lever*

8058-019

# OPERATION

6. Move throttle control to full throttle.
7. Engage the mower deck by pulling out the blade switch.

The machine's speed and direction are continuously variable using the two steering controls. When both controls are in the neutral position, the machine stands still.

By moving both controls an equal amount forward or backward, the machine moves in a straight line forward or backward respectively.

In order, for example, to turn right while moving forward, move the right control towards the neutral position. The rotation of the right wheel is reduced and the machine turns to the right.

Turning on the spot (zero turn) can be achieved by moving one control backward (behind the neutral position) and carefully moving the other steering control forward from its neutral position.

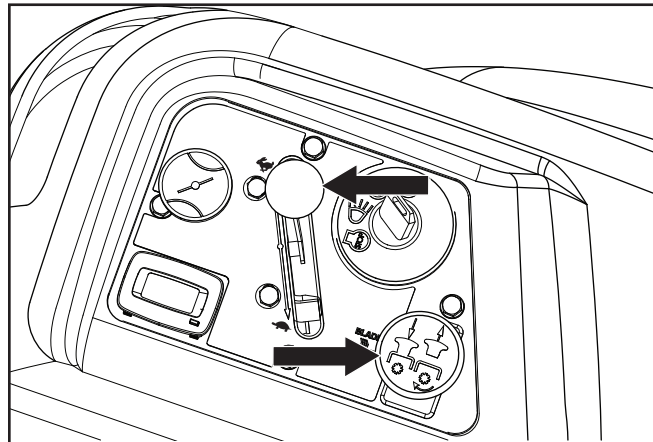

8058-149

*Set blade engagement and throttle control*

## Operating On Hills

Read the Safety Instructions "Driving on Slopes" in the "Safety Instructions".



### **WARNING!**

**Do not drive up or down hills with slopes greater than 10 degrees. Do not drive across slopes.**

- The slowest speed possible should be used before starting up or down hills.
- Avoid stopping or changing speed on hills.
- If stopping is absolutely necessary, pull steering controls into the neutral position and push to the outside of the unit. Engage the parking brake.

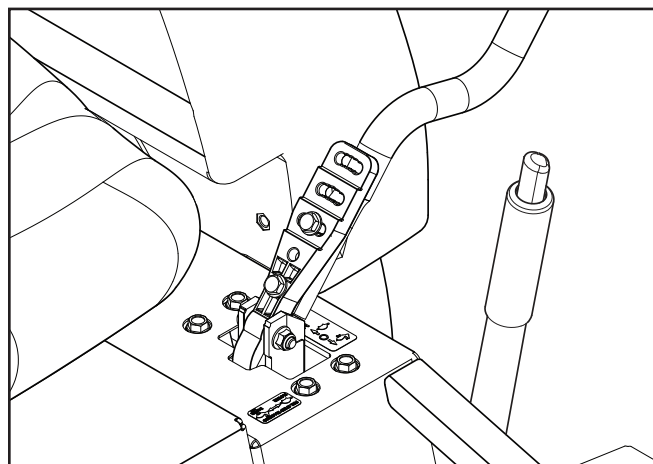

8058-077

*Place controls in neutral position*

### **IMPORTANT INFORMATION**

**Control levers return to neutral when released. This may cause the mower to suddenly stop.**

- To restart movement, release the parking brake.
- Pull the control levers back to the center of the mower and press forward to regain forward motion.
- Make all turns slowly.

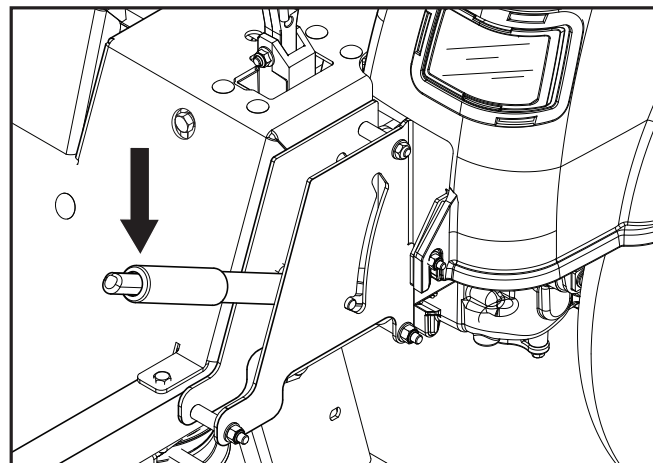

8058-080

*Parking brake released*

# OPERATION

## Mowing Tips

- Observe and flag rocks and other fixed objects to avoid collisions.
- Begin with a high cutting height and reduce it until the desired mowing result is attained. The average lawn should be cut to 2½" (64 mm) during the cool season and over 3" (76 mm) during the hot months. For healthier and better looking lawns, mow often after moderate growth. For best cutting performance, grass over 6" (15 cm) in height should be mowed twice. Make the first cut relatively high, the second to the desired height.
- The mowing result will be best with a high engine speed (the blades rotate rapidly) and low speed (the rider moves slowly). If the grass is not too long and dense, the driving speed can be increased without negatively affecting the mowing result.
- The finest lawns are obtained by mowing often. The lawn becomes more even and the grass clippings more evenly distributed over the mown area. The total time taken is not increased as a higher operating speed can be used without poor mowing results.
- Avoid mowing wet lawns. The mowing result is poorer because the wheels sink into the soft lawn, clumps build, and the grass clippings fasten under the cowling.
- Hose the mower deck underside with water after each use. When cleaning, the mower deck shall be raised into the transport position. Make sure the mower is cooled and the engine is off.
- Use compressed air to clean top surface of the deck. Avoid flooding water on top surface, engine and electrical components.
- When the mulching kit is used, it is important that the mowing interval is frequent.



### WARNING!

**Clear the lawn of stones and other objects that can be thrown out by the blades.**

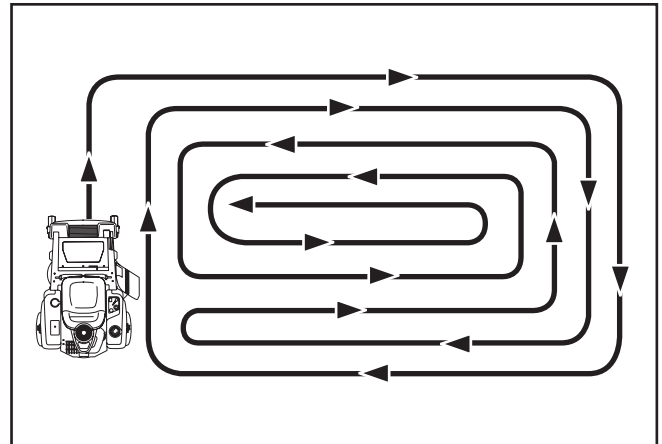

*Mowing pattern*

8011-603



### WARNING!

**Never drive the rider on terrain that slopes more than 10 degrees. Mow slopes up and down, never side to side. Avoid sudden directional changes.**

# OPERATION

## Stopping the Engine

Allow the engine to idle a minute in order to attain normal operating temperature before stopping it, if it has been worked hard. Avoid idling the engine for longer periods, as there is a risk of the spark plugs fouling.

- Disengage the mower deck by depressing the blade switch.

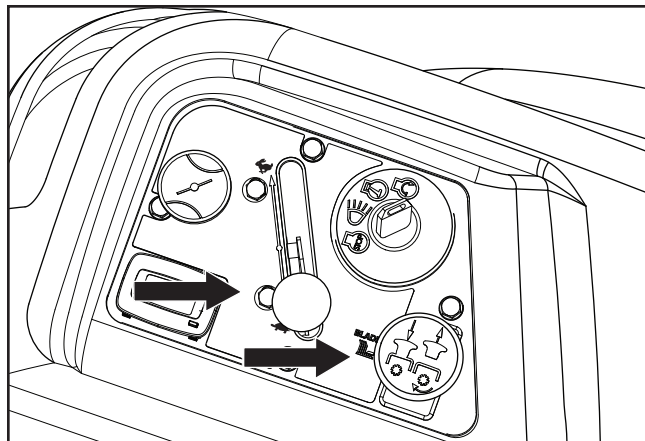

8058-134

*Disengage the mower deck and move throttle to minimum*

- Raise the mower deck by pressing the release button on the lever and pulling fully backward to the transport position.

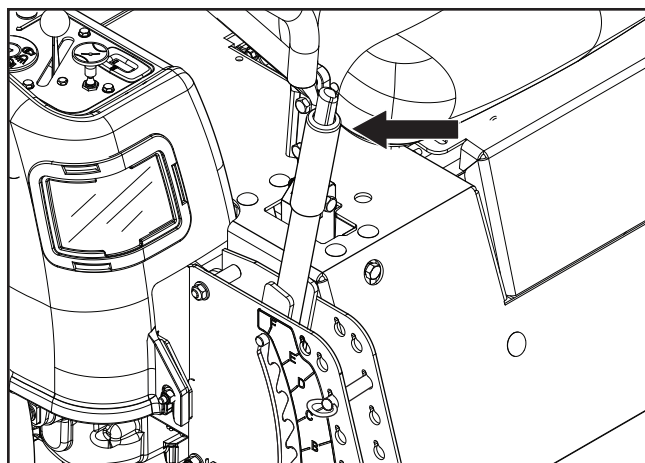

8058-019

*Mower deck lifting lever*

- Move the throttle to the minimum position (tortoise symbol). Turn the ignition key to the stop position.
- Move the steering controls outward.
- Remove key. Always remove key when leaving the mower to prevent unauthorized use.

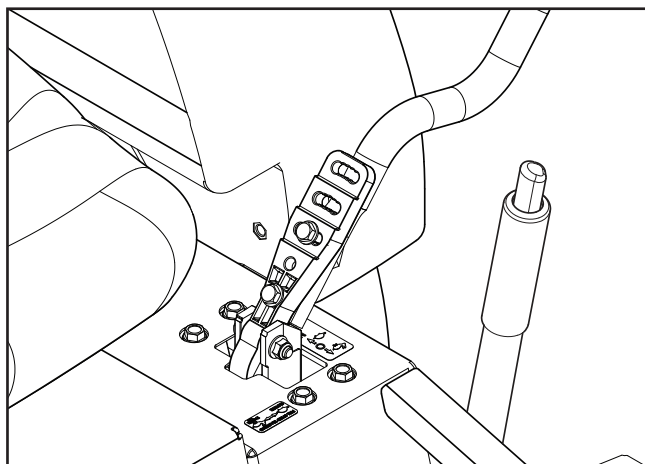

8061-077

*Place controls in neutral position to stop*

### IMPORTANT INFORMATION

**Leaving the ignition switch in any other position than "OFF" will cause the battery to be discharged.**



# OPERATION

## Manual Transport

When pushing or pulling the mower, engage the EZT (Integrated Zereturn Transaxle) bypass linkages. The EZT bypass linkages are located on the rear of the frame, below the rear engine guard.

1. Raise the deck into the highest cutting position.
2. Pull the EZT bypass linkages up and out of the keyhole slots. Release the levers with the head outside the frame and held in the bypass position.
3. To reengage the EZT's to drive, reverse the above procedure.



### WARNING!

**Use extreme caution when loading the machine into a truck or trailer using ramps. There is the possibility of serious injury or death if the machine falls off the ramps.**

Load the machine into truck or trailer by driving up ramps in low gear. **DO NOT LIFT!** The machine is not intended to be lifted by hand.

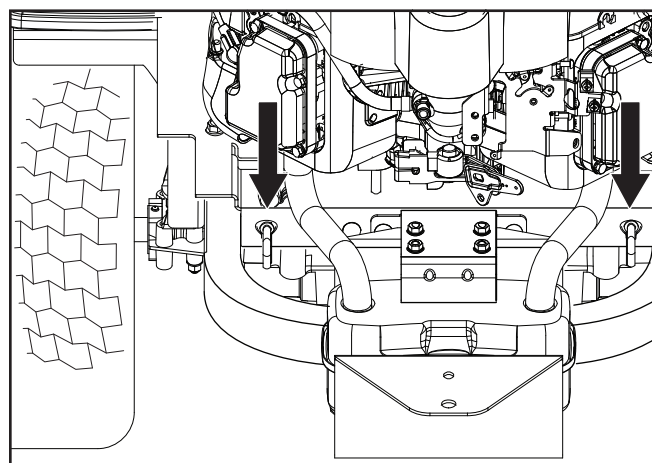

8058-150

*Bypass linkages*

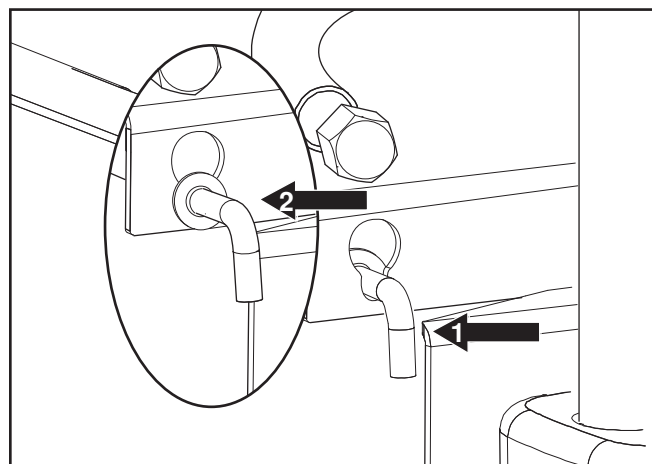

8058-033

1. EZT engaged
  2. EZT locked in the bypass
- Bypass linkage - left hand side*

# MAINTENANCE

## Maintenance Schedule

The following is a list of maintenance procedures that must be performed on the machine. For those points not described in this manual, visit an authorized service workshop. An annual service carried out by an authorized service workshop is recommended to maintain your machine in the best possible condition and to ensure safe operation.

Read *General Maintenance* in the **Safety** section.

MAINTENANCE	Daily		At least once each year	Maintenance interval in hours			
	Before	After		25	50	100	300
Check the parking brake	●						
Check the engine's oil level (every refueling)	■						
Check the safety system	●						
Check for fuel and oil leakages	◆						
Check/clean the engine's cooling air intake		■					
Check the mower deck		●					
Check for loose hardware (screws, nuts)		●					
Clean under the mower deck		●					
Start the engine and blades, listen for unusual sounds		◆					
Check for damage		◆					
Thoroughly clean around the engine		◆					
Clean around belts, belt pulleys		◆					
Check the tire pressures				●			
Check battery connections				●			
Sharpen <sup>3)</sup> / Replace mower blades				●			
Clean the engine's cooling air intake <sup>2)</sup>			■	■			
Clean the air cleaner's pre-filter <sup>2)</sup> (foam)			■	■			
Clean the air cleaner's filter cartridge <sup>2)</sup> (paper filter)			■				
Check/adjust the parking brake			◆		◆		
Inspect muffler/spark arrester			◆		◆		

<sup>1)</sup> First change after 8-10 hours. When operating with a heavy load or at high ambient temperatures, replace every 50 hours. <sup>2)</sup> In dusty conditions, cleaning and replacement are required more often. <sup>3)</sup> Performed by authorized service workshop.

● = Described in this manual

◆ = Not described in this manual

■ = Refer to the engine manufacturer's manual

# MAINTENANCE

MAINTENANCE	Daily		At least once each year	Maintenance interval in hours			
	Before	After		25	50	100	300
Check/adjust throttle cable						■	
Check the condition of belts, belt pulleys			●			●	
Change the engine oil <sup>1)</sup>			■		■		
Replace the engine oil filter			■			■	
Clean/replace the spark plugs			■			■	
Replace the fuel filter			●			●	
Replace air filter <sup>2)</sup> (paper filter)			■			■	
Check the caster wheels (every 200 hours)			●			●	
Replace the air cleaner's pre-filter <sup>2)</sup> (foam)			■				
Check/adjust the mower deck			●				●
Check the engine valve clearance <sup>3)</sup>			◆				◆
Perform the 300-hour service <sup>3)</sup>			◆				◆

<sup>1)</sup> First change after 5-8 hours. When operating with a heavy load or at high ambient temperatures, replace every 50 hours. <sup>2)</sup> In dusty conditions, cleaning and replacement are required more often. <sup>3)</sup> Performed by authorized service workshop.

● = Described in this manual

◆ = Not described in this manual

■ = Refer to the engine manufacturer's manual



## WARNING!

### Before performing any service or adjustment checklist

- Engage the parking brake.
- Place the Blade-switch in the disengaged position.
- Turn the ignition switch to "OFF" position and remove the key.
- Make sure the blades and all moving parts have completely stopped.
- Disconnect the spark plug wire from all spark plugs and place the wire where it cannot come in contact with the plug.

# MAINTENANCE

## Battery

Your mower is equipped with a maintenance free battery and does not need servicing. However, periodic charging of the battery with an automotive type battery charger will extend its life.

- Keep battery and terminals clean.
- Keep battery bolts tight.
- See chart for charging times.

STANDARD BATTERY	STATE OF CHARGE	APPROXIMATE BATTERY CHARGING TIME* TO FULL CHARGE AT 80°F / 27°C			
		Maximum Rate at:			
		50 Amps	30 Amps	20 Amps	10 Amps
12.6V	100%	<b>- FULL CHARGE -</b>			
12.4V	75%	20 min.	35 min.	48 min.	90 min.
12.2V	50%	45 min.	75 min.	95 min.	180 min.
12.0V	25%	65 min.	115 min.	145 min.	280 min.
11.8V	0%	85 min.	150 min.	195 min.	370 min.

\*Charging time depends on battery capacity, condition, age, temperature and efficiency of charger

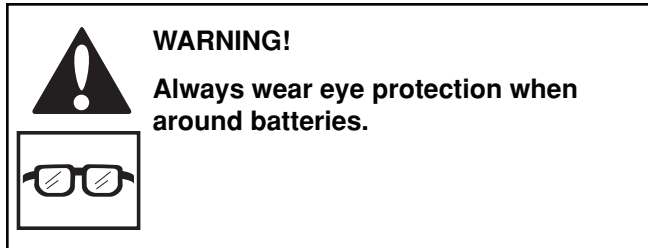

**IMPORTANT INFORMATION**

Do not attempt to open or remove caps or covers. Adding or checking level of electrolyte is not necessary.

Always use two wrenches for the terminal screws.

## Cleaning battery and terminals

Corrosion and dirt on the battery and terminals can cause the battery to “leak” power.

1. Open the terminal access doors.
2. Disconnect BLACK battery cable first, then the RED battery cable and remove the battery from the machine.
3. Rinse the battery with plain water and dry.
4. Clean terminals and battery cable ends with wire brush until shiny.
5. Coat terminals with grease or petroleum jelly.
6. Reinstall battery.

## Replacing battery

1. Lift seat and rotate forward.
2. Using two ½" wrenches disconnect BLACK battery cable then RED battery cable.
3. Position deck to lowest setting.
4. Front underside of frame, remove the nuts that secure the battery hold-down.
5. Carefully remove the battery from the mower.
6. Install new battery with terminals in the same position as the old battery.
7. Reinstall battery hold-down and secure with nuts removed in Step 4.
8. Reconnect RED battery cable to positive (+) battery terminal with bolt and hex nut.
9. Connect BLACK grounding cable to negative (-) battery terminal with remaining hex bolt and hex nut
10. Replace terminal boot cover.
11. Lower seat

**WARNING!**

Do not short battery terminals by allowing a wrench or any other object to contact both terminals at the same time. Before connecting battery, remove metal bracelets, wristwatch bands, rings, etc.

Positive terminal must be connected first to prevent sparks from accidental grounding.

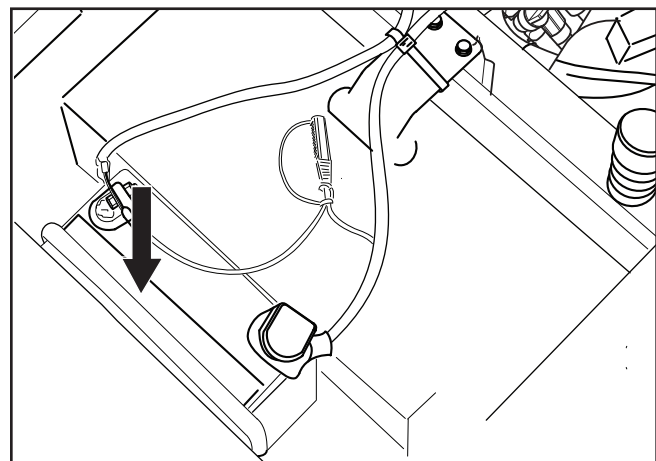

Remove battery hold-down to replace battery

8050-109

# MAINTENANCE

## Safety System

The machine is equipped with a safety system that prevents starting or driving under the following conditions.

The engine can only be started when:

1. The mower deck is disengaged.
2. The steering controls are in the outer, locked neutral position.
3. The parking brake is on.

Make daily inspections to ensure that the safety system works by attempting to start the engine when one of the conditions is not met. Change the conditions and try again.

If the machine starts when one of these conditions is not met, turn the machine off and repair the safety system before using the machine again.

Make sure the engine stops when the park brake is not engaged and the operator leaves the seated position.

Check that the engine stops if the mower blades are engaged and the driver temporarily moves off the drivers seat.

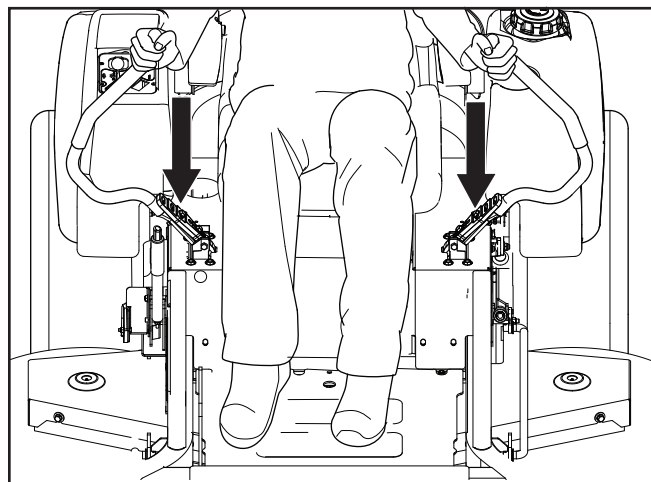

8058-078

*Steering controls locked in neutral*

### IMPORTANT INFORMATION

**In order to be able to drive, the driver must sit in the seat and release the parking brake before the steering controls can be moved into the neutral position, otherwise the engine will stop.**

## Parking Brake

Visually check that no damage is found on the lever, cables, or switch belonging to the parking brake. Perform a standstill test and check that there is sufficient braking action.

To adjust the parking brake, contact the Dixon service workshop.

### IMPORTANT INFORMATION

**The machine must be absolutely standing still when applying the parking brake.**



### WARNING!

**Faulty adjustment will result in reduced braking ability and can cause an accident.**

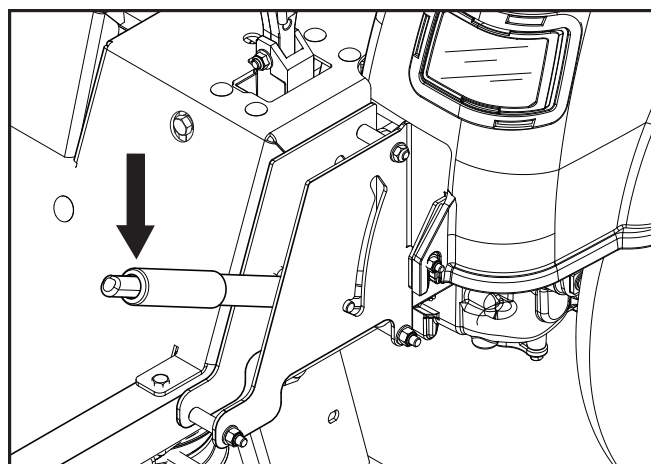

8058-080

*Parking brake*

# MAINTENANCE

## V-belts

Check every 100 hours of operation. Check for severe cracking and large nicks.

NOTE: The belt will show some small cracks in normal operation.

The belts are not adjustable. Replace belts if they begin to slip from wear.

## Deck Belt

1. Park on a level surface. Apply parking brake.
2. Lower the deck into the lowest cutting position.
3. Remove bolts from belt shields and remove shields.
4. Remove any dirt or grass that may have accumulated around the cutter housings and entire deck surface.
5. Carefully roll the belt over the top of the cutter housing pulleys and remove belt.

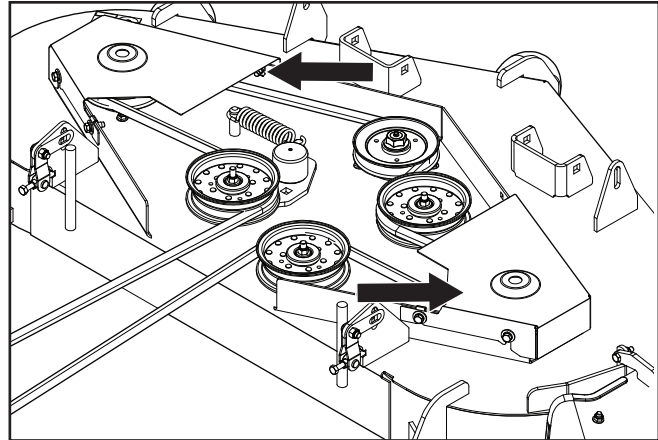

8058-088

*Remove belt shields*

## Deck belt installation

*NOTE: For ease in installing the deck belt, refer to the routing decal on the top of the deck.*

1. Wrap the deck belt around the electric clutch pulley that is located on the engine shaft.
2. Route the belt forward and up onto the deck.
3. Place belt around spring loaded idler pulley.
4. Wrap the belt around the stationary idler pulley and around the mandrel housings.
5. Push inward on the idler arm and carefully route belt over stationary idler pulley. Once belt is properly routed, slowly release idler arm to tension belt.
6. Double check belt routing to make sure it **matches the decal affixed to the deck**, and the belt does not have any twist. Correct as needed.
7. Replace belt shields on both mandrel housings and secure with fasteners.

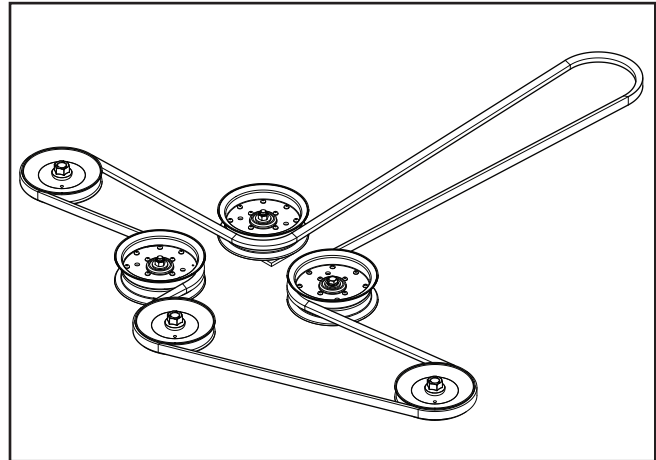

8050-843

*Belt routing*

# MAINTENANCE

## Cutting Blades

To attain the best mowing effect, it is important that blades are well sharpened and not damaged.

Replace blades that have been bent or cracked when hitting obstacles.

### IMPORTANT INFORMATION

**The sharpening of blades should be carried out by an authorized service workshop.**

Let the service workshop decide whether a blade with large nicks can be repaired/ground or must be replaced. Balance the blades after sharpening. Check the blade mounts.



### WARNING!

**Blades are sharp. Protect your hands with gloves and/or wrap blades with a heavy cloth when handling.**



## Blade replacement

1. Remove blade bolt by turning counterclockwise.
2. Install new or resharpened blade with stamped **GRASS SIDE** facing towards ground/grass (down) or **THIS SIDE UP** facing deck and cutter housing.
3. Seat the blade's opening firmly onto the cutter housing.
4. Tighten blade bolt securely.
5. Torque blade bolt to 90 ft/lbs (122 Nm).

### IMPORTANT INFORMATION

**Special blade bolt is heat treated.**

**Replace with a Dixon bolt if required.**

**Do not use lower grade hardware than specified.**

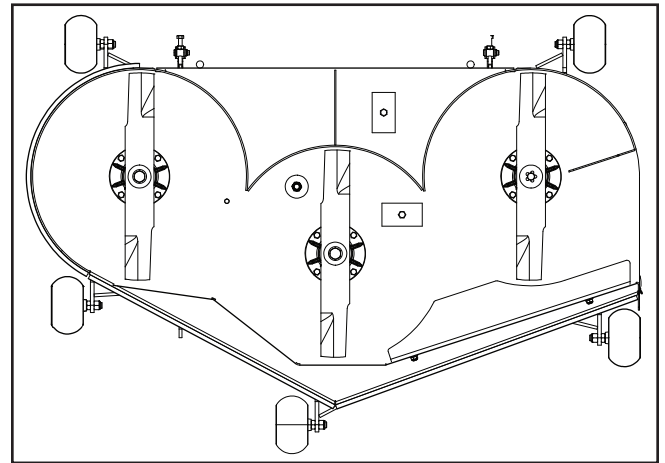

8011-604-1

*Check the blades*

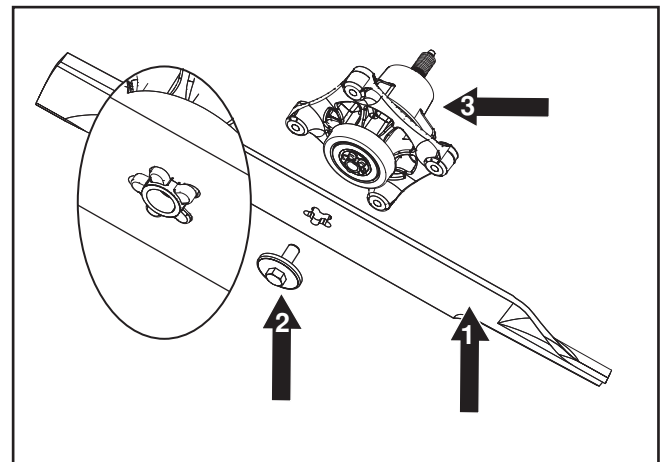

8058-027

1. Blade
2. Blade bolt (special)
3. Cutter housing

*Blade attachment*

# MAINTENANCE

## Adjusting the Mower Deck

### Leveling deck

Adjust the deck while the mower is on a level surface. Make sure the tires are inflated to the correct pressure. See *Technical Data* under **Transmission**. If tires are under or over inflated, the deck cannot be properly adjusted.

The deck should be adjusted slightly higher in the rear.

NOTE: To insure accuracy of leveling procedure, mower deck drive belt must be installed prior to leveling deck.

1. Wear heavy gloves. Turn each outer blade tip to align front to rear with the deck (1) or side-to-side (2).
2. Measure from the floor surface up to the bottom of the blade tip on the discharge side of the mower deck. Record the measurement.
3. Move to the opposite side, check that measurement is the same. If adjustment is required—with a  $\frac{3}{4}$ " or adjustable wrench, turn the lift link adjustment nuts on either side counter clockwise to lower or clockwise to raise. Adjust until both measurements are equal.

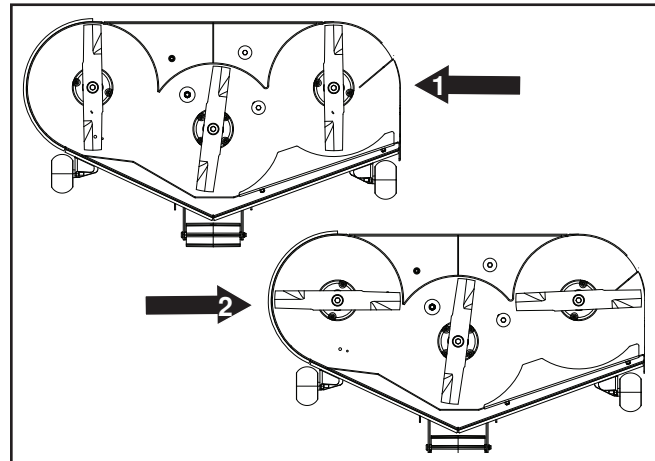

8058-030

*Align blades to begin measurements*

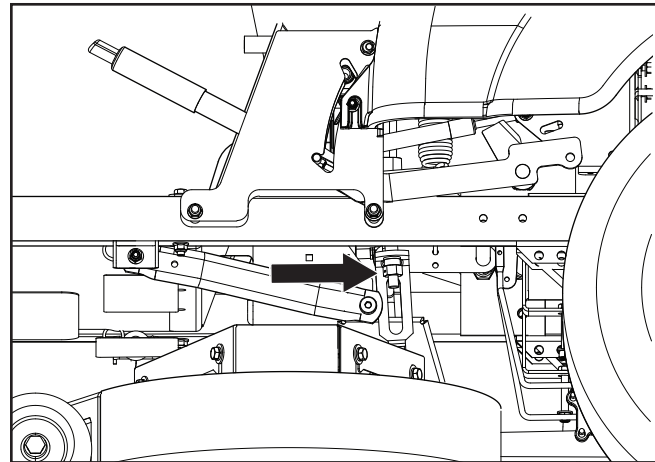

8058-030

*Lift link adjustment nut*

4. Turn any blade to align with the deck in front-to-rear manner. If the front blade tip does not measure  $\frac{1}{8}$ " to  $\frac{1}{2}$ " higher in the rear—with a  $\frac{5}{8}$ " or adjustable wrench, turn the nuts on the front suspension linkage. Clockwise raises the front of the mower, counterclockwise will lower the front. Adjust nuts until rear of mower deck is positioned level to  $\frac{1}{8}$ " higher in the rear than the side-to-side measurement.

NOTE: This will place the mower deck in a standard measurement position. Additional adjustments may be required to achieve desired cut for grass type or mowing conditions.

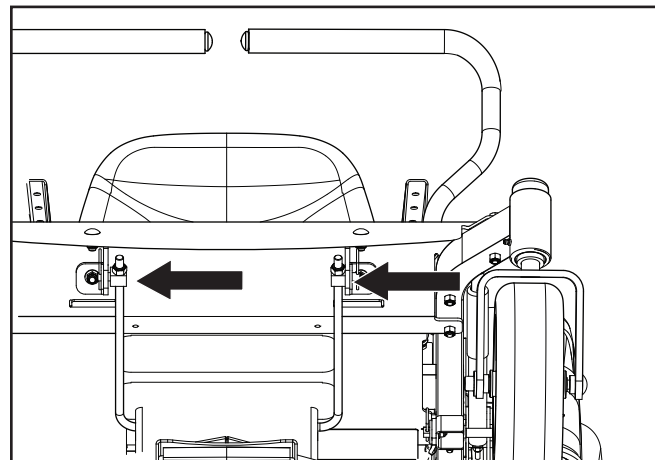

8058-031

*Deck front adjustment nuts*



# MAINTENANCE

## Anti-scalp Rollers

### IMPORTANT INFORMATION

**Adjust anti-scalp rollers with the mower on a flat level surface.**

Anti-scalp rollers are properly adjusted when they are just slightly off of the ground when the deck is at the desired cutting height in the operating position. Anti-scalp rollers then keep the deck in the proper position to help prevent scalping in most terrain conditions. Anti-scalp rollers can be set in four positions. The rollers should be approximately  $\frac{1}{4}$ " (6.5 mm) from ground. Do not adjust the rollers to support the deck.

### IMPORTANT INFORMATION

**To avoid deck damage, the anti-scalp rollers must not be adjusted to support the deck.**

## Tire Pressures

All tires should be at 15 psi / 103 kPa / 1 bar.

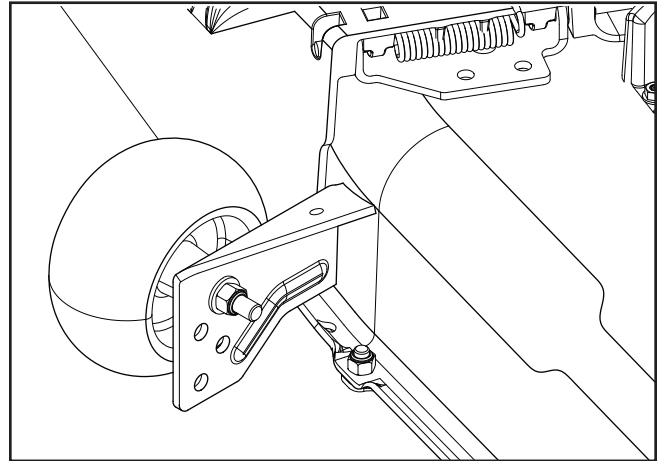

*Anti-scalp rollers*

8058-135

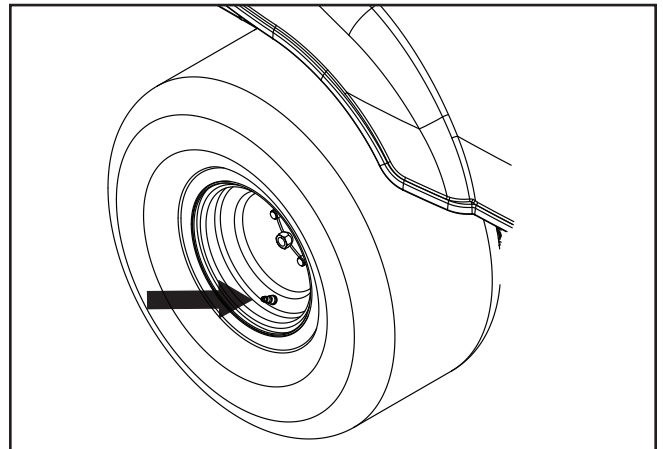

*Check tire pressures*

8011-564

# MAINTENANCE

## Caster Wheels

Check every 200 hours. Check that wheels rotate freely. If wheels do not rotate freely take the unit to your dealer for service.

Foam filled tires or solid tires will void the warranty.

### Removal and installation

1. Remove nut and caster bolt.
2. Pull the wheel out of the yoke and take care of the spacers.
3. Install in reverse order. Tighten caster bolt.

### IMPORTANT INFORMATION

**DO NOT add any type of tire liner or foam fill material to the tires. Excessive loads created by foam filled tires will cause premature failures.**

**Only use O.E.M. specified tires.**

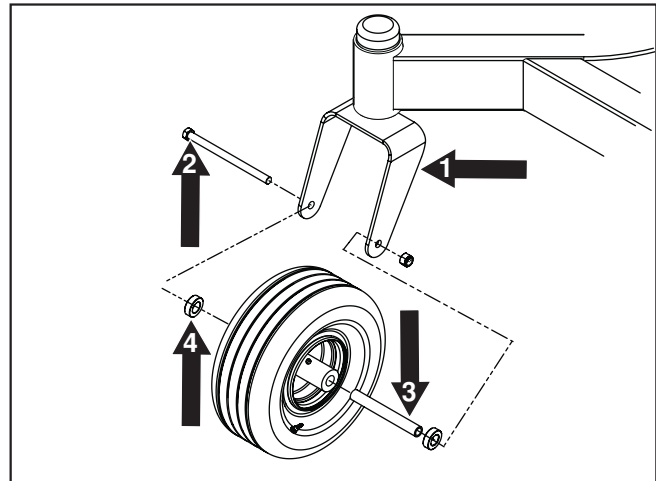

8011-619-4

1. Caster yoke
  2. Caster bolt
  3. Caster long spacer
  4. Caster small spacers
- Caster wheels*

## Cleaning

Regular cleaning, especially under the mower deck, will increase the machine's life-span. Make it a habit to clean the machine directly after use (after it is cooled), before the debris sticks.

Do not spray water on the top of the mower deck. Use compressed air to clean the top side of mower deck. Regularly clean the underside of the deck with normal water pressure. Do not use a high pressure washer or steam cleaner. Avoid spraying engine and electrical components with water.

*For models fitted with a cleanout port*, attach the quick connect (from the accessory packet) to any garden hose. After mowing, snap the hose to the cleanout port and turn on water supply.

Restart the mower and engage the blades to use the spinning action to wash away debris. Make sure the hose is away from the mower blades.

Do not rinse hot surfaces with cold water. Let unit cool before washing.



### IMPORTANT INFORMATION

**Use protective glasses when cleaning and washing.**

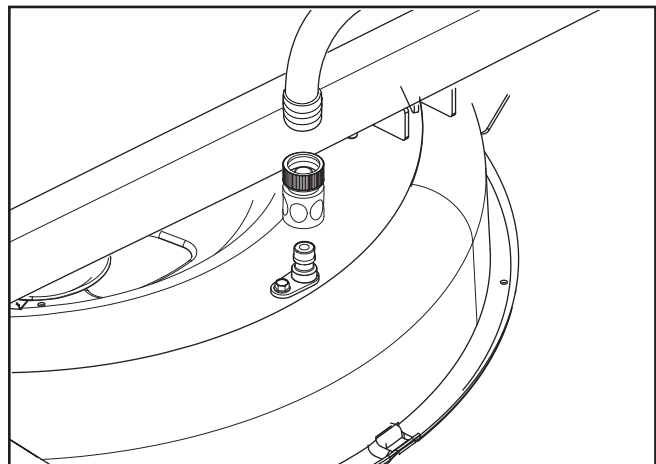

8058-084

*Clean regularly*

## Hardware

Check daily. Inspect the entire machine for loose or missing hardware.

# LUBRICATION

12/12	1/52	1/365		25h	50h	100h	200h	300h	
				(2x)					
				(2x)					
				(2x)					
		5		6					
				*					

8050-832

12/12 Every year 1/52 Every Week 1/365 Every day	Lubricate with grease gun Oil change	Filter change Level check
--	---	------------------------------

## General

Remove the ignition key to prevent unintentional movements during lubrication.

When lubricating with an oil can, it must be filled with engine oil.

When lubricating with grease, unless otherwise stated, use a high grade molybdenum disulphide grease.

For daily use, the machine should be lubricated twice weekly.

Wipe away excess grease after lubrication.

It is important to avoid getting lubricant on the belts or the drive surfaces on the belt pulleys. Should this happen, attempt to clean them with spirits. If the belt continues to slip after cleaning, it must be replaced. Gasoline or other petroleum products must not be used to clean belts.

# LUBRICATION

## Front Wheel Mount

Lubricate with a grease gun, one zerk for each wheel mount, until the grease is forced out.

Use only good quality bearing grease.

Grease from well-known brand names (petrochemical companies) usually maintains a good quality.

## Front Wheel Bearings

Lubricate with a grease gun, one zerk for each set of wheel bearings, until the grease is forced out.

Use only good quality bearing grease.

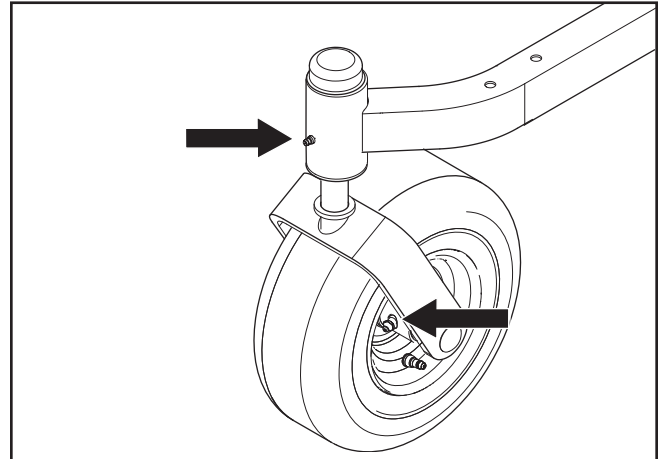

8058-068

*Lubricating the front wheels*

### IMPORTANT INFORMATION

**Use minimal lubrication and remove excess lubricant so that it does not come into contact with belts or belt pulley drive surfaces.**

## Deck Spindles

Lower the cutting deck completely.

If a grease gun without a rubber hose is used, the foot plate must be removed.

Lubricate with a grease gun, 2-3 strokes per spindle.

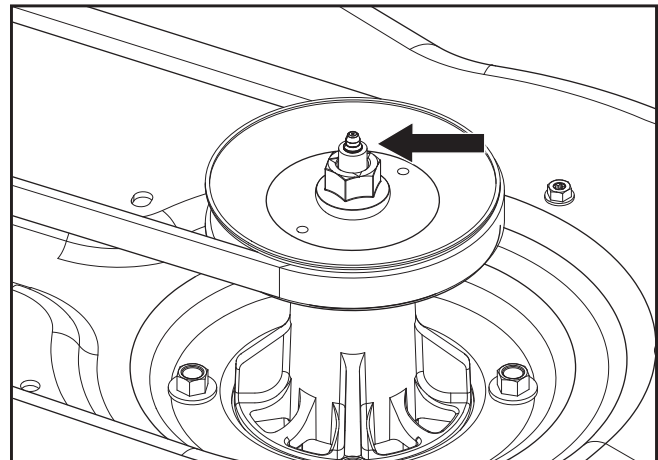

8058-136

*Deck spindle*

## Transmission

The transmission is maintenance free with no need for level checks or oil changes. If a leak occurs, replace the unit or contact your Dixon dealer.

# TROUBLESHOOTING

---

Problem	Cause
Engine will not start	<ul style="list-style-type: none"><li>• Blade switch is engaged.</li><li>• Steering controls are not locked in the neutral position</li><li>• Parking brake is not activated</li><li>• Battery is dead</li><li>• Contamination in the carburetor or fuel line.</li><li>• Fuel supply is closed or the shutoff valve for the fuel tank is in the wrong position</li><li>• Clogged fuel filter or fuel line</li><li>• Ignition system faulty</li></ul>
Starter does not turn the engine over	<ul style="list-style-type: none"><li>• Battery is dead</li><li>• Poor contact of the battery terminal cable connections</li><li>• Blown fuse</li><li>• Fault in the starter safety circuit. See <b>Safety System</b> in the <b>Maintenance</b> Section</li></ul>
Engine runs rough	<ul style="list-style-type: none"><li>• Faulty carburetor</li><li>• Choke control is pulled out with a warm engine</li><li>• Clogged fuel filter or jet</li><li>• Clogged ventilation valve on the fuel cap</li><li>• Fuel tank nearly empty</li><li>• Fouled spark plugs</li><li>• Rich fuel mixture or fuel-air mixture.</li><li>• Wrong fuel type</li><li>• Water in fuel</li><li>• Clogged air filter</li></ul>
Engine seems weak	<ul style="list-style-type: none"><li>• Clogged air filter</li><li>• Fouled spark plugs</li><li>• Carburetor incorrectly adjusted</li><li>• Air trapped in hydraulic system</li></ul>
Machine vibrates	<ul style="list-style-type: none"><li>• Blades are loose</li><li>• Blades are incorrectly balanced</li><li>• Engine is loose</li></ul>

# TROUBLESHOOTING

---

Problem	Cause
Engine overheats	<ul style="list-style-type: none"><li>• Clogged air intake or cooling fins</li><li>• Engine overloaded</li><li>• Poor ventilation around engine</li><li>• Defective engine speed regulator</li><li>• Too little or no oil in the engine</li><li>• Contamination in the carburetor or fuel line.</li><li>• Fouled spark plugs</li></ul>
Battery not charging	<ul style="list-style-type: none"><li>• Poor contact of the battery terminal cable connections</li><li>• Charging lead is disconnected</li></ul>
The machine moves slowly, unevenly, or not at all	<ul style="list-style-type: none"><li>• Parking brake on</li><li>• Bypass valve on pump open</li><li>• Drive belt for the transmission slack or has come off</li><li>• Air trapped in hydraulic system</li></ul>
Mower deck not engaging	<ul style="list-style-type: none"><li>• Drive belt for the mower deck has come loose</li><li>• Contact for the electromagnetic coupling has loosened</li><li>• Blade switch is faulty or has come loose from cable contact</li><li>• Blown fuse</li></ul>
Transaxle leaks oil	<ul style="list-style-type: none"><li>• Damaged seals, housing, or gaskets</li><li>• Air trapped in hydraulic system</li></ul>
Uneven mowing results	<ul style="list-style-type: none"><li>• Different air pressure in tires on the left and right sides.</li><li>• Bent blades</li><li>• Suspending for the mower deck is uneven</li><li>• Blades are dull</li><li>• Driving speed too high</li><li>• Grass is too long</li><li>• Grass collected under the mower deck</li></ul>

# STORAGE

## Winter Storage

At the end of the mowing season (or if it will not be in use for more than 30 days), the machine should be readied for storage. Fuel allowed to stand for long periods of time (30 days or more) can leave sticky residues that can plug the carburetor and disrupt engine function.

Fuel stabilizers are an acceptable option as regards to the sticky residues that can occur during storage. Add stabilizer to the fuel in the tank or in the storage container. Always use the mixing ratios specified by the manufacturer of the stabilizer. Run the engine for at least 10 minutes after adding the stabilizer so that it reaches the carburetor. Do not empty the fuel tank and the carburetor if you have added stabilizer



### **WARNING!**

**Never store an engine with fuel in the tank indoors or in poorly ventilated spaces where fuel vapor can come in contact with open flames, sparks, or a pilot light such as in a boiler, hot water tank, clothes dryer, etc. Handle the fuel with care. It is very flammable and can cause serious personal injury and property damage. Drain the fuel into an approved container outdoors and store far away from open flame or sources of ignition.**

**Never use gasoline for cleaning. Use a degreaser and warm water instead.**

To ready the machine for storage:

1. Thoroughly clean the machine, especially under the mower deck. Touch up damage to the paint and spray a thin layer of oil on the underside of the mower deck to avoid corrosion.
2. Inspect the machine for worn or damaged parts and tighten any nuts or screws that may have become loose.
3. Change the engine oil; dispose of properly.
4. Empty the fuel tanks or add a fuel stabilizer. Start the engine and allow it to run until the carburetor is drained of fuel or the stabilizer has reached the carburetor.
5. Remove the spark plug and pour about a tablespoon of engine oil into the cylinder. Turn over the engine so that the oil is evenly distributed and then refit the spark plug.
6. Lubricate all grease zerks, joints, and axles.
7. Remove the battery. Clean, charge, and store the battery in a cool place, but protect it from direct cold.
8. Store the machine in a clean, dry place and cover it for extra protection.

## Service

When ordering spare parts, please specify the purchase year, model, type, and serial number.

Always use genuine Dixon spare parts.

An annual check-up at an authorized service workshop is a good way to ensure that your machine performs its best the following season.

# SCHEMATICS

**NOTES:**

1. SEAT UNOCCUPIED
2. BRAKE SWITCH IN OFF POSITION
3. MOTION CONTROL LEVERS OUT
4. PTO IN OFF POSITION

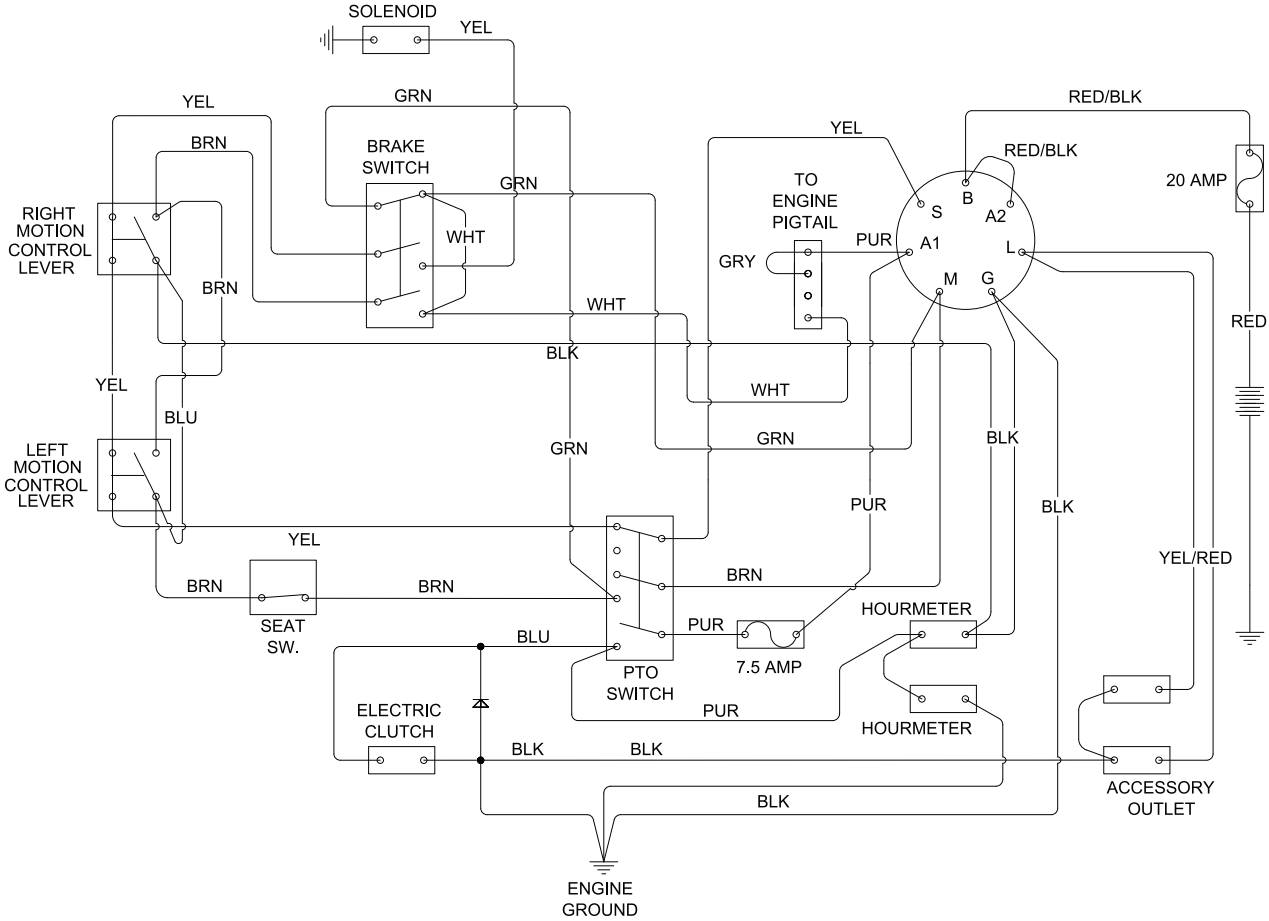

**KEY SWITCH POSITIONS**

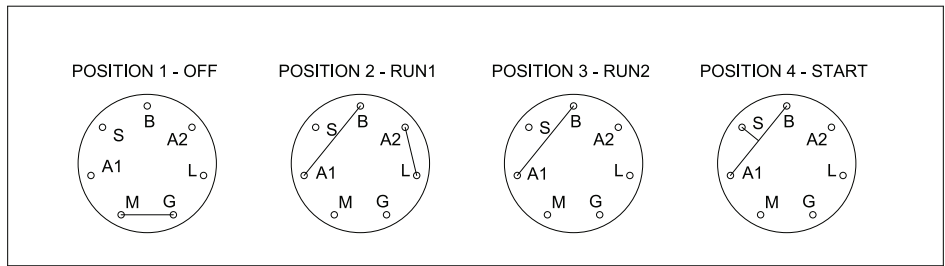



# TECHNICAL DATA

	<b>966657601</b>	<b>966657701</b>
<b>Engine</b>		
Manufacturer	Kawaskai	Briggs & Stratton
Type	FR 651-V	Pro
Power	22 hp <sup>(1,2)</sup>	22 hp <sup>(1,2)</sup>
Lubrication	Pressure with oil filter	Pressure with oil filter
Fuel	Min 87 octane unleaded (Max ethanol 10%, Max MTBE 15%)	Min 87 octane unleaded (Max ethanol 10%, Max MTBE 15%)
Fuel tank capacity	3 gallons / 11.4 liters	3 gallons / 11.4 liters
Cooling	Air cooled	Air cooled
Air filter	Standard	Standard
Alternator	12V	12V
Starter	Electric	Electric
<b>Transmission</b>		
Transmission	Hydrostatic transaxles	Hydrostatic transaxles
Speed and direction controls	Dual levers, foam gripped	Dual levers, foam gripped
Speed forward	0-6 mph / 0-9.7 km/h	0-6 mph / 0-9.7 km/h
Speed reverse	0-3.5 mph / 0-5.6 km/h	0-3.5 mph / 0-5.6 km/h
Brakes	Mechanical parking brake	Mechanical parking brake
Front caster tires, smooth tread	13 x 5.0-6, 4 ply	13 x 5.0-6, 4 ply
Rear tires, turf pneumatic	18 x 8.5-8	18 x 8.5-8
Tire pressure	15 PSI / 103 kPa / 1 bar	15 PSI / 103 kPa / 1 bar

<sup>(1)</sup> The power rating of the engines indicated is the average net power output (at specified rpm) of a typical production engine for the engine model measured to SAE standard J1349/ISO1585. Mass production engines may differ from this value. Actual power output for the engine installed in the final machine will depend on the operating speed, environmental conditions and other variables.

<sup>(2)</sup> Refer to the engine manufacturer's owner manual for engine specifications.

## TECHNICAL DATA

	<b>966657601</b>	<b>966657701</b>
<b>Frame</b>		
Cutting Width	42" / 107cm	42" / 107cm
Cutting Height	1.5 - 4" / 3.8 - 10.2 cm	1.5 - 4" / 3.8 - 10.2 cm
Uncut Circle	0	0
Number of Blades	3	3
Blade Length	22 <sup>3</sup> / <sub>4</sub> " / 57.8 cm	22 <sup>3</sup> / <sub>4</sub> " / 57.8 cm
Nose Rollers	Yes	Yes
Sprung Seat	Standard	Standard
Hinged Arm Rests	Optional	Optional
Hour Meter	Standard	Standard
Blade Engagement	Electric clutch	Electric clutch
Deck Construction	Fabricated	Fabricated
Productivity	2.6 acres/h / 10521 m <sup>2</sup> /h	2.6 acres/h / 10521 m <sup>2</sup> /h
<b>Dimension</b>		
Weight	538 lbs / 244 kgs	538 lbs / 244 kgs
Base Machine Length	75" / 191cm	75" / 191cm
Base Machine Height	40" 102cm	40" 102cm
Base Machine Width	39.2" / 100 cm	39.2" / 100 cm
Overall Width, Chute Up	43" / 109 cm	43" / 109 cm
Overall Width, Chute Down	52" / 132 cm	52" / 132 cm

# TECHNICAL DATA

	<b>966657201, 966657901 966658001</b>	<b>966698601</b>
<b>Engine</b>		
Manufacturer	Briggs & Stratton	Kohler
Type	Pro	Courage
Power	22 hp <sup>(1,2)</sup>	24 hp <sup>(1,2)</sup>
Lubrication	Pressure with oil filter	Pressure with oil filter
Fuel	Min 87 octane unleaded (Max ethanol 10%, Max MTBE 15%)	Min 87 octane unleaded (Max ethanol 10%, Max MTBE 15%)
Fuel tank capacity	3 gallons / 11.4 liters	3 gallons / 11.4 liters
Cooling	Air cooled	Air cooled
Air filter	Standard	Standard
Alternator	12V	12V
Starter	Electric	Electric
<b>Transmission</b>		
Transmission	Hydrostatic transaxles	Hydrostatic transaxles
Speed and direction controls	Dual levers, foam gripped	Dual levers, foam gripped
Speed forward	0-6 mph / 0-9.7 km/h	0-6 mph / 0-9.7 km/h
Speed reverse	0-3.5 mph / 0-5.6 km/h	0-3.5 mph / 0-5.6 km/h
Brakes	Mechanical parking brake	Mechanical parking brake
Front caster tires, smooth tread	13 x 5.0-6, 4 ply	13 x 5.0-6, 4 ply
Rear tires, turf pneumatic	18 x 8.5-8	18 x 9.5-8
Tire pressure	15 PSI / 103 kPa / 1 bar	15 PSI / 103 kPa / 1 bar

<sup>(1)</sup> The power rating of the engines indicated is the average net power output (at specified rpm) of a typical production engine for the engine model measured to SAE standard J1349/ISO1585. Mass production engines may differ from this value. Actual power output for the engine installed in the final machine will depend on the operating speed, environmental conditions and other variables.

<sup>(2)</sup> Refer to the engine manufacturer's owner manual for engine specifications.

# TECHNICAL DATA

	<b>966657801, 966657901 966658001</b>	<b>966698601</b>
<b>Engine</b>		
Manufacturer	Briggs & Stratton	Kohler
Type	Pro	Courage
Power	22 hp <sup>(1,2)</sup>	24 hp <sup>(1,2)</sup>
Lubrication	Pressure with oil filter	Pressure with oil filter
Fuel	Min 87 octane unleaded (Max ethanol 10%, Max MTBE 15%)	Min 87 octane unleaded (Max ethanol 10%, Max MTBE 15%)
Fuel tank capacity	3 gallons / 11.4 liters	3 gallons / 11.4 liters
Cooling	Air cooled	Air cooled
Air filter	Standard	Standard
Alternator	12V	12V
Starter	Electric	Electric
<b>Transmission</b>		
Transmission	Hydrostatic transaxles	Hydrostatic transaxles
Speed and direction controls	Dual levers, foam gripped	Dual levers, foam gripped
Speed forward	0-6 mph / 0-9.7 km/h	0-6 mph / 0-9.7 km/h
Speed reverse	0-3.5 mph / 0-5.6 km/h	0-3.5 mph / 0-5.6 km/h
Brakes	Mechanical parking brake	Mechanical parking brake
Front caster tires, smooth tread	13 x 5.0-6, 4 ply	13 x 5.0-6, 4 ply
Rear tires, turf pneumatic	18 x 8.5-8	18 x 9.5-8
Tire pressure	15 PSI / 103 kPa / 1 bar	15 PSI / 103 kPa / 1 bar

<sup>(1)</sup> The power rating of the engines indicated is the average net power output (at specified rpm) of a typical production engine for the engine model measured to SAE standard J1349/ISO1585. Mass production engines may differ from this value. Actual power output for the engine installed in the final machine will depend on the operating speed, environmental conditions and other variables.

<sup>(2)</sup> Refer to the engine manufacturer's owner manual for engine specifications.

## TECHNICAL DATA

	<b>966657801, 966657901 966658001</b>	<b>966658201, 966658401</b>
<b>Frame</b>		
Cutting Width	46" / 117 cm	48" / 122 cm
Cutting Height	1.5 - 4" / 3.8 - 10.2 cm	1.5 - 4" / 3.8 - 10.2 cm
Uncut Circle	0	0
Number of Blades	2	3
Blade Length	15" / 38 cm	16¼" / 41.3 cm
Nose Rollers	No	Yes
Sprung Seat	Standard	Standard
Hinged Arm Rests	Optional	Optional
Hour Meter	Standard	Standard
Blade Engagement	Electric clutch	Electric clutch
Deck Construction	Stamped	11 gauge w/10 gauge skirts
Productivity	2.6 acres/h / 10521 m <sup>2</sup> /h	2.47 acres/h / 9996 m <sup>2</sup> /h
<b>Dimensions</b>		
Weight	525 lbs / 238 kg	525 lbs / 2438 kg
Base Machine Length	75" / 191 cm	75" / 191 cm
Base Machine Height	40" / 102 cm	40" / 102 cm
Base Machine Width	41¾" / 106 cm	43¾" / 112 cm
Overall Width, Chute Up	48" / 122 cm	48" / 122 cm
Overall Width, Chute Down	56" / 142 cm	67½" / 142 cm

## TECHNICAL DATA

---

	<b>966658201, 966658401</b>
<b>Frame</b>	
Cutting Width	54" / 137cm
Cutting Height	1.5 - 4" / 3.8 - 10.2 cm
Uncut Circle	0
Number of Blades	3
Blade Length	18¼" / 46.4 cm
Nose Rollers	No
Sprung Seat	Standard
Hinged Arm Rests	Optional
Hour Meter	Standard
Blade Engagement	Electric clutch
Deck Construction	Stamped
Productivity	3.3 acres/h / 13354 m <sup>2</sup> /h
<b>Dimensions</b>	
Weight	538 lbs / 244 kg
Base Machine Length	75" / 191 cm
Base Machine Height	40" / 102 cm
Base Machine Width	43¾" / 112 cm
Overall Width, Chute Up	57" / 145 cm
Overall Width, Chute Down	67½" / 171 cm

# TECHNICAL DATA

## Accessories

Collection system

### Torque Specifications

Engine crankshaft bolt	50 ft/lb (67 Nm)	Standard 1/4" fasteners	9 ft/lb (12 Nm)
Deck pulley bolts	150 ft/lb (203 Nm)	Standard 5/16" fasteners	18 ft/lb (25 Nm)
Lug nuts	75 ft/lb (100 Nm)	Standard 3/8" fasteners	33 ft/lb (44 Nm)
Blade bolt	90 ft/lb (122 Nm)	Standard 7/16" fasteners	52 ft/lb (70 Nm)
		Standard 1/2" fasteners	80 ft/lb (110 Nm)

### HEX HEAD CAP SCREWS

The torque values shown should be used as a general guideline when specific torque values are not given.

#### U.S. Standard Hardware

Shank Size (Diameter in inches, fine or coarse thread)	Grade	SAE Grade 5		SAE Grade 8		Flangelock Screw w/Flangelock Nut	
	Size	ft./lbs	Nm	ft./lbs	Nm	ft./lbs	Nm
	1/4	9	12	13	18		
	5/16	18	24	28	38	24	33
	3/8	31	42	46	62	40	54
	7/16	50	68	75	108		
	1/2	75	102	115	156		
	9/16	110	150	165	224		
	5/8	150	203	225	305		
	3/4	250	339	370	502		
	7/8	378	513	591	801		
	1 1/8	782	1060	1410	1912		

\*\* Grade 5 - Minimum commercial quality (lower quality not recommended)

#### Metric Standard Hardware

Shank Size (Diameter in millimeters, fine or coarse thread)	Grade	Grade 8.8		Grade 10.9		Grade 12.9	
	Size	ft./lbs	Nm	ft./lbs	Nm	ft./lbs	Nm
	M4	1.5	2	2.2	3	2.7	3.6
	M5	3	4	4.5	6	5.2	7
	M6	5.2	7	7.5	10	8.2	11
	M7	8.2	11	12	16	15	20
	M8	13.5	18	18.8	25	21.8	29
	M10	24	32	35.2	47	43.5	58
	M12	43.5	58	62.2	83	75	100
	M14	70.5	94	100	133	119	159
	M16	108	144	147	196	176	235
	M18	142	190	202	269	242	323
	M20	195	260	275	366	330	440
	M22	276	368	390	520	471	628
	M24	353	470	498	664	596	794
	M27	530	707	474	996	904	1205

# CONFORMITY CERTIFICATES

---

## **USA requirements**

Labels are placed on the engine and/or in the engine compartment stating that the machine will fulfill the requirements. This is also applicable to special requirements for any of the states, (California emission rules etc.). Do not remove any of these labels. Certificates can also be supplied with the machine at delivery or written in the Engine manual. Take care of them as they are valuable documents.



# SERVICE JOURNAL

Action	Date, mtr reading, stamp, sign
<b>Delivery Service</b>	
Charge the battery	<input type="checkbox"/>
Adjust the tire pressure of all wheels to 15 PSI (1 bar)	<input type="checkbox"/>
Mount the steering controls in the normal position	<input type="checkbox"/>
Connect the contact box to the cable for the seat's safety switch	<input type="checkbox"/>
Check that the right amount of oil is in the engine	<input type="checkbox"/>
Adjust the position of the steering controls	<input type="checkbox"/>
Fill with fuel and open the fuel shut off valve	<input type="checkbox"/>
Start the engine	<input type="checkbox"/>
Check that there is drive to both wheels	<input type="checkbox"/>
Check the mower deck adjustment	<input type="checkbox"/>
Check:	
The safety switch for the parking brake	<input type="checkbox"/>
The safety switch for the mower deck	<input type="checkbox"/>
The safety switch in the seat	<input type="checkbox"/>
The safety switch in the steering controls	<input type="checkbox"/>
Parking brake functionality	<input type="checkbox"/>
Driving forward	<input type="checkbox"/>
Driving backward	<input type="checkbox"/>
Engaging the blades	<input type="checkbox"/>
Check the idle speed	<input type="checkbox"/>
Check the engine high idle speed	<input type="checkbox"/>
Inform the customer about:	
The need and advantages of following the service schedule	<input type="checkbox"/>
The need and advantages of leaving the machine for service every 300 hours	<input type="checkbox"/>
The effects of service and maintaining a service journal on the machine's resale value	<input type="checkbox"/>
Application areas for mulching	<input type="checkbox"/>
Fill in the sales papers, etc.	Delivery service has been carried out No remaining notes Certified:

# SERVICE JOURNAL

Action	Date, mtr reading, stamp, sign
<p><b>After the First 10 Hours</b> Change engine oil</p>	<input type="checkbox"/>
Action	Date, mtr reading, stamp, sign
<p><b>25-Hour Service</b> Check the fuel pump's air filter Sharpen/Replace mower blades if required Check the tire pressures Check battery with cables Lubricate according to lubrication chart Check/clean the engine's cooling air intake Clean the air cleaner's pre-filter (foam)</p>	<input type="checkbox"/> <input type="checkbox"/> <input type="checkbox"/> <input type="checkbox"/> <input type="checkbox"/> <input type="checkbox"/> <input type="checkbox"/>

# SERVICE JOURNAL

Action	Date, mtr reading, stamp, sign
<p><b>50-Hour Service</b></p> <p>Perform the 25-hour service</p> <p>Clean/replace the air cleaner's filter cartridge (paper filter (shorter intervals for dusty operating conditions))</p> <p>Change engine oil</p> <p>Lubricate according to lubrication chart</p> <p>Check/adjust the parking brake</p>	<input type="checkbox"/>  <input type="checkbox"/>  <input type="checkbox"/>  <input type="checkbox"/>  <input type="checkbox"/>
<p><b>100-Hour Service</b></p> <p>Perform the 25-hour service</p> <p>Perform the 50-hour service</p> <p>Change the engine oil filter</p> <p>Clean/replace the spark plugs</p> <p>Replace the fuel filter</p> <p>Check V-belts</p> <p>Check tighten caster wheel axle bolts (every 200 hours)</p> <p>Change the air filter's paper cartridge</p> <p>Change hydraulic pump oil and filter. (200 hours)</p>	<input type="checkbox"/>  <input type="checkbox"/>  <input type="checkbox"/>  <input type="checkbox"/>  <input type="checkbox"/>  <input type="checkbox"/>  <input type="checkbox"/>  <input type="checkbox"/>  <input type="checkbox"/>  <input type="checkbox"/>

# SERVICE JOURNAL

Action	Date, mtr reading, stamp, sign
<p><b>300-Hour Service</b></p> <p>Perform the 25-hour service</p> <p>Perform the 50-hour service</p> <p>Perform the 100-hour service</p> <p>Check/adjust the mower deck</p> <p>Clean the combustion chamber and grind the valve seats</p> <p>Check the engine valve clearance</p> <p>Replace the air cleaner's pre-filter (foam)</p>	<input type="checkbox"/> <input type="checkbox"/> <input type="checkbox"/> <input type="checkbox"/> <input type="checkbox"/> <input type="checkbox"/> <input type="checkbox"/>
<p><b>At Least Once Each Year</b></p> <p>Clean the engine's cooling air intake (25 hours)</p> <p>Replace the air cleaner's pre-filter (foam) (300 hours)</p> <p>Replace the air filter's paper cartridge</p> <p>Change the engine oil (50 hours)</p> <p>Replace the engine oil filter (100 hours)</p> <p>Check/adjust the cutting height</p> <p>Check/adjust the parking brake (50 hours)</p> <p>Clean/Change the spark plugs (100 hours)</p> <p>Change the fuel filter (100 hours)</p> <p>Check the engine valve clearance</p>	<input type="checkbox"/> <input type="checkbox"/> <input type="checkbox"/> <input type="checkbox"/> <input type="checkbox"/> <input type="checkbox"/> <input type="checkbox"/> <input type="checkbox"/> <input type="checkbox"/> <input type="checkbox"/>







