

SR 1600 Art. 7946

- D Betriebsanleitung**
Teichschlammsauger
-
- GB Operating Instructions**
Pond Silt Remover
-
- F Mode d'emploi**
Aspirateur de bassin
-
- NL Instructies voor gebruik**
Vijvervuilzuiger
-
- S Bruksanvisning**
Slamsugare för damm
-
- I Istruzioni per l'uso**
Pulitore per laghetti
-
- E Manual de instrucciones**
Aspirador de lodo para estanque
-
- P Instruções de utilização**
Aspirador de lodo de lago
-
- DK Brugsanvisning**
Bassinstøvsuger

GARDENA Pond Silt Remover SR 1600

Welcome to the Garden with GARDENA...



Translation of the original instructions from German. Please read these operating instructions carefully and observe the notes given. Use these operating instructions to familiarise yourself with the Pond Silt Remover, its proper use and the notes on safety.



For safety reasons, children under the age of 16 and people who have not read these operating instructions must not use this Pond Silt Remover.

Persons with reduced physical or mental abilities may use the product only if they are supervised or instructed by a responsible person.

→ Please keep these operating instructions in a safe place.

Contents

| | |
|--|----|
| 1. Where to Use Your GARDENA Pond Silt Remover | 10 |
| 2. Safety instructions | 10 |
| 3. Function | 11 |
| 4. Assembly | 12 |
| 5. Operation | 13 |
| 6. Storage | 14 |
| 7. Maintenance | 14 |
| 8. Troubleshooting | 15 |
| 9. Technical data | 15 |
| 10. Service / Warranty | 16 |

1. Where to Use Your GARDENA Pond Silt Remover

Correct use:

As a Pond Silt Remover: The Pond Silt Remover is suitable for the removal of particles of dirt up to 20 mm, thread algae, leaves and silt from garden ponds, and for removal of large particles of dirt from swimming pools.

As a Wet Suction Pump: The Pond Silt Remover is suitable for suction of dirty water with particles of dirt up to 20 mm.

For dry suction: The pond silt remover can also be used for dry suction with the filter bag.

Please note



The GARDENA Pond Silt Remover is not suitable for continuous operation (e.g. industrial applications, continuous pumping operations).

2. Safety instructions

Operation:

When working by a pond always ensure the equipment is securely mounted.

Do not apply sustained tension to the hoses.

Avoid sucking up oversize particles of dirt – they could block the Pond Silt Remover.

Never make any technical modifications to the equipment.

Always use original spare parts and

accessories for the equipment.

Repairs must only be carried out by GARDENA Service centres.



DANGER! Risk of explosion!
Never use the equipment in the vicinity of explosive liquids or vapours. The equipment is not protected for use in explosive environments.

The Pond Silt Remover must not be used for suction of flammable or poisonous materials (such as petrol, asbestos, asbestos dust, copier toner) or volatile substances, acids, hot or glowing ashes, dust, sand or similar dry dirty materials.

The Pond Silt Remover must always have its foam filter in place when in use.

The foam filter is only suitable for liquids. When in use as a Wet Suction Unit do not suck up any dry dust or dirt – this can lead to damage.

Electrical safety:



DANGER! Electric shock!

Do not operate the equipment if there are people or animals in the pond or suction area.

Before reaching into the water, always unplug the mains plugs of all equipment in the water.

Compare the mains electrical power supply with the information on the packaging / on the model plate on the equipment.

Make sure that the equipment is supplied through a residual current protection device measuring a residual current of 30 mA or less.

Only connect the equipment to a properly installed socket outlet.

Keep the mains plug and all connection points dry!

Do not use the equipment in the rain or leave it out in the rain.

Lay the connection cable so that it is protected and cannot be damaged.

Use only permitted extension cables as per HD 516.

→ Ask your electrical specialist.

Never lift or carry the equipment by the connection cable!

Do not use the equipment if the cable or housing is defective!

Electrical installations at garden ponds must satisfy the applicable national and international installation regulations.

Never open the housing of the equipment or its associated parts unless you are expressly instructed so to do in the Operating Instructions.

If you have questions or encounter problems, for your own safety refer to a qualified electrician!

3. Function

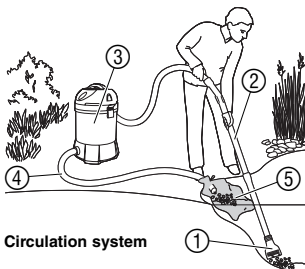

Circulation system

The Pond Silt Remover sucks the pond water into the collecting tank ③ via the adapter nozzle ① and suction pipe ②.

When the collecting tank is full, the Pond Silt Remover releases the dirty water via the drainage hose ④ over a 25 second period.

Circulation system:

The water flows back into the pond ⑤ through the fine filter bag. This means no pond water is lost, and the biological equilibrium of the pond is maintained. The water that is fed back contains biologically active floating particles. The resulting turbidity of the pond can last several days.

Discharge system:

The pond water that is sucked out is discharged into the environment. The fine filter bag ⑤ can also be used for this.

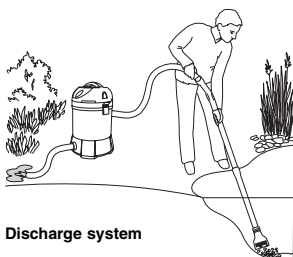

Discharge system

Fine filter bag:

The particles of dirt and pond silt that are collected in the fine filter bag ⑤ can be used as fertiliser or disposed of in the compost.

Applications of the various adapter nozzles

Bottom nozzle



For sucking pond silt up from the bottom of the pond.

The bottom nozzle can be adjusted to suit the conditions at the bottom of the pond:

- Bottom nozzle fully open (10 mm): use on pond liners (no pebbles on the bottom, thick layer of silt).
- Bottom nozzle closed (2 mm): use on pond liners (pebbles as bottom covering, thick layer of silt).

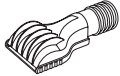

For optimum suction in rigid pond liners and of thin layers of silt, turn the bottom nozzle through 180°.

Joints nozzle



For sucking from narrow spaces, such as between stones and plants.

Thread algae nozzle



For sucking up thread algae.

Wide nozzle with rubber lip

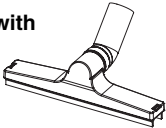

For sucking up residual water e.g. on terraces, in garages, cellar etc.

4. Assembly

Fitting the Pond Silt Remover / Wet Suction Unit / Dry Suction Unit:

1. Undo the filter tray locks ⑥ and remove the motor housing ⑦.
2. Remove all parts from the filter tray ③.
3. Replace the motor housing ⑦ and lock it in position.
4. Insert the end piece of the suction hose ⑧ into the upper suction opening of the filter tray ③.
5. Attach the transparent suction tube ②a to the handle ⑨.
6. Attach the black suction tubes ②.

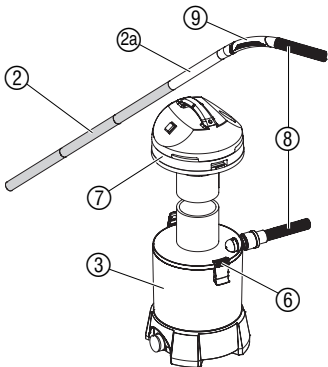

5. Operation

Use as a Pond Silt Remover:

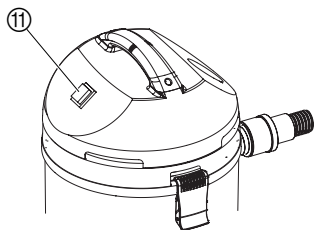
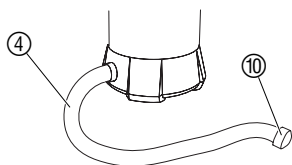
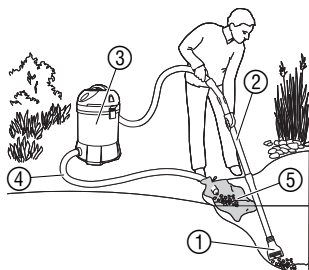

The higher the filter tray ③ above the surface of the water, the less the suction power.

1. Pull mains plug of pond silt remover out of electric socket.
2. Position the filter tray ③ at least 2 m from the edge of the pond, max. 0.5 m above the surface of the water and so that it will not overflow.
3. Insert the round end of the discharge hose ④ into the lower discharge opening of the filter tray ③.

The non-return flap ⑩ is located at the outlet of the discharge hose ④.

4. Lay the discharge hose ④ on ground with a falling gradient, so that the hose is self-draining.
5. If desired, attach the fine filter bag ⑤ over the end of the discharge hose ④ (see 3. Function).
6. Attach the desired nozzle ① (see 3. Function) to the suction tube ②.
7. Insert the Pond Silt Remover mains plug into a power socket.
8. Set the ON switch ⑪ to position **(I) ON**.

When the collecting tank is full, the dirty water is drained via the discharge hose ④ over a 25 second period. Then the pond silt remover switches itself on again automatically.

9. Guide the nozzle on to the bottom of the pond. Then suck up the dirt with slow and even movements.
10. After use, turn the ON switch ⑪ to the **(0) OFF** position.

Operation as Wet Suction Unit:

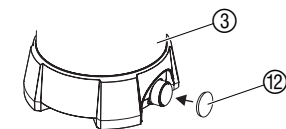

1. Pull mains plug of Wet Suction Unit out of electric socket.
2. Insert stopper plug ⑫ in the lower discharge opening of the filter tray ③.
3. Attach the wide nozzle ① (see 3. Function) to the suction tube ②.
4. Insert the Wet Suction Unit mains plug into a power socket.
5. Set the ON switch ⑪ to position **(I) ON**.
When the collecting tank is full, the suction unit switches off.
6. When it stops sucking, the filter tray ③ is full. Then set the switch ⑪ to position **(0) OFF**.
7. At the chosen discharge location remove the stopper plug ⑫ and empty the filter tray ③.

Operation as a Dry Suction Unit:

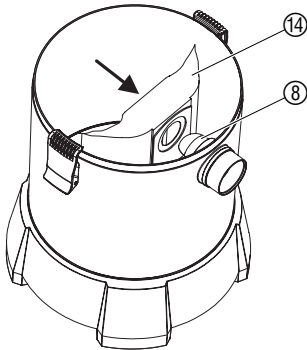

The filter bag ⑭ must be used when the system is operated as a dry suction unit.

1. Pull mains plug of the Dry Suction Unit out of the socket.
2. Remove motor housing (see 4. Assembly).
3. Put the enclosed filter bag ⑭ on over the end piece of the suction hose ⑧.
4. Refit motor housing (see 4. Assembly).
5. Fit the nozzle required (see 3. Function) on the suction pipe.
6. Plug the mains plug of the dry suction unit into an electric socket.
7. Set the ON switch ⑪ to position **(I) ON**.
8. After use, turn the ON switch ⑪ to the **(0) OFF** position.

A new Filter Bag **Art. 7946-00.900.50** can be ordered from GARDENA Service.

6. Storage

Storage:



Store out of the reach of children.

→ Clean the Pond Silt Remover (see 7. Maintenance) and store in a frost-free place.

Disposal:

(in accordance with
RL 2002/96/EC)



The product must not be added to normal household waste. It must be disposed of in line with local environmental regulations.

7. Maintenance

Pond Silt Remover cleaning:



DANGER! Electric shock!

→ **Before any maintenance work, unplug the equipment from the mains.**

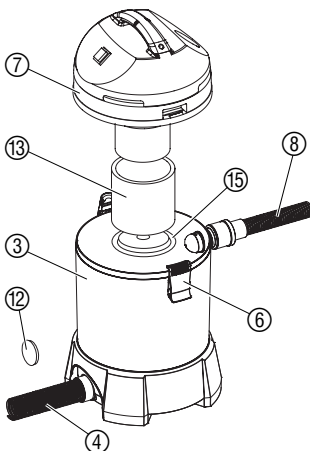

1. Remove the suction hose ⑧, discharge hose ④ or stopper plug ⑫ from the filter tray ③.
2. Undo the filter tray locks ⑥ and remove the motor housing ⑦.
3. Remove filter cover ⑮ (bayonet fitting).
4. Remove the foam filter ⑬ from motor housing ⑦.
5. Wash out the filter tray ③ and foam filter ⑬ with clean water. Replace the foam filter ⑬ if necessary.
6. Wash out all hoses and nozzles with clean water.
7. Reassemble the Pond Silt Remover (see 4. Assembly).

The foam filter can be ordered from GARDENA Service.

8. Troubleshooting



DANGER! Electric shock!

→ **Disconnect the Pond Silt Remover at the mains before rectifying any faults.**

| Problem | Probable Cause | Remedy |
|---|---|---|
| The Pond Silt Remover sucks nothing up | Discharge hose wrongly fitted. | → The non-return flap in the discharge hose should not be plugged into the filter tray and must be at the outlet from the discharge hose. |
| | Pond Silt Remover too high above the surface of the water. | → Position the Pond Silt Remover max. 0.5 m above the surface of the water. |
| Reduced suction power | Foam filter, suction tube, suction hose or fine filter bag dirty. | → Clean the Pond Silt Remover (see 7.Maintenance). |
| | The filter bag is full. | → Replace filter bag. |
| The Pond Silt Remover does not empty | Discharge hose kinked or laid without a falling gradient. | → Lay the discharge hose so that it is not kinked and has a slightly falling gradient. |
| | Filter tray and discharge hose dirty. | → Clean filter tray and discharge hose. |

CAUTION!



Work on the electrical parts must only be carried out by GARDENA Service.

If other faults occur, please contact GARDENA Service.

9. Technical data

SR 1600 (Art. 7946)

| | |
|--|------------------|
| Mains voltage / mains frequency | 230 V AC / 50 Hz |
| Rated power | 1400 W |
| Connection cable | 4 m H05-VV |
| Max. suction height | 1.6 m |
| Filter tray volume | Approx. 27 l |
| Suction hose length | 4 m |
| Discharge hose length | 2 m |
| Max. particle size for suction | 20 mm |
| Liquid temperature | 4 °C - 35 °C |
| Noise level ¹⁾ | < 85 dB (A) |

¹⁾ according to 98/37/EC

10. Service / Warranty

GARDENA guarantees this product for 2 years (starting from the date of purchase). This guarantee covers all serious defects of the unit that can be proved to be material or manufacturing faults. Under warranty we will either replace the unit or repair it free of charge if the following conditions apply:

- The unit must have been handled properly and in keeping with the requirements of the operating instructions.
- Neither the purchaser or a non-authorised third party have attempted to repair the unit.

The wearing parts filter foam, valve rubbers and filter bag are excluded from the warranty.

This manufacturer's guarantee does not affect the user's existing warranty claims against the dealer/seller.

If a fault occurs with your Pond Silt Remover, please return the faulty unit together with a copy of the receipt and a description of the fault, with postage paid to one of the GARDENA Service Centres listed on the back of these operating instructions.

| | |
|---|---|
| <p>D <i>Produkthftung</i></p> | <p>Wir weisen ausdrücklich darauf hin, dass wir nach dem Produkthaftungsgesetz nicht für durch unsere Geräte hervorgerufene Schäden einzustehen haben, sofern diese durch unsachgemäße Reparatur verursacht oder bei einem Teileaustausch nicht unsere Original GARDENA Teile oder von uns freigegebene Teile verwendet werden und die Reparatur nicht vom GARDENA Service oder dem autorisierten Fachmann durchgeführt wird. Entsprechendes gilt für Ergänzungssteile und Zubehör.</p> |
| <p>GB <i>Product Liability</i></p> | <p>We expressly point out that, in accordance with the product liability law, we are not liable for any damage caused by our products if it is due to improper repair or if parts exchanged are not original GARDENA parts or parts approved by us, and, if the repairs were not carried out by a GARDENA Service Centre or an authorised specialist. The same applies to spare parts and accessories.</p> |
| <p>F <i>Responsabilité</i></p> | <p>Nous vous signalons expressément que GARDENA n'est pas responsable des dommages causés par ses appareils, dans la mesure où ces dommages seraient causés suite à une réparation non conforme, dans la mesure où, lors d'un échange de pièces, les pièces d'origine GARDENA n'auraient pas été utilisées, ou si la réparation n'a pas été effectuée par le Service Après-Vente GARDENA ou l'un des Centres SAV agréés GARDENA. Ceci est également valable pour tout ajout de pièces et d'accessoires autres que ceux préconisés par GARDENA.</p> |
| <p>NL <i>Productaansprakelijkheid</i></p> | <p>Wij wijzen er nadrukkelijk op, dat wij op grond van de wet aansprakelijkheid voor producten niet aansprakelijk zijn voor schade ontstaan door onze apparaten, indien deze door onvakkundige reparatie veroorzaakt zijn, of er bij het uitwisselen van onderdelen geen gebruik gemaakt werd van onze originele GARDENA onderdelen of door ons vrijgegeven onderdelen en de reparatie niet door de GARDENA technische dienst of de bevoegde vakman uitgevoerd werd. Ditzelfde geldt voor extra-onderdelen en accessoires.</p> |
| <p>S <i>Produktansvar</i></p> | <p>Tillverkaren är inte ansvarig för skada som orsakats av produkten om skadan beror på att produkten har reparerats felaktigt eller om, vid reparation eller utbyte, andra än Original GARDENA reservdelar har använts. Samma sak gäller för kompletteringsdelar och tillbehör.</p> |
| <p>I <i>Responsabilità del prodotto</i></p> | <p>Si rende espressamente noto che, conformemente alla legislazione sulla responsabilità del prodotto, non si risponde di danni causati da nostri articoli se originati da riparazioni eseguite non correttamente o da sostituzioni di parti effettuate con materiale non originale GARDENA o comunque da noi non approvato e, in ogni caso, qualora l'intervento non venga eseguito da un centro assistenza GARDENA o da personale specializzato autorizzato. Lo stesso vale per le parti complementari e gli accessori.</p> |
| <p>E <i>Responsabilidad de productos</i></p> | <p>Advertimos que conforme a la ley de responsabilidad de productos no nos responsabilizamos de daños causados por nuestros aparatos, siempre y cuando dichos daños hayan sido originados por arreglos o reparaciones indebidas, por recambios con piezas que no sean piezas originales GARDENA o bien piezas autorizadas por nosotros, así como en aquellos casos en que la reparación no haya sido efectuada por un Servicio Técnico GARDENA o por un técnico autorizado. Lo mismo es aplicable para las piezas complementarias y accesorios.</p> |
| <p>P <i>Responsabilidade sobre o produto</i></p> | <p>Queremos salientar que segundo a lei da responsabilidade do fabricante, nós não nos responsabilizaremos por danos causados pelo nosso equipamento, quando estes ocorram em decorrência de reparações inadequadas ou da substituição de peças por peças não originais da GARDENA, ou peças não autorizadas. A responsabilidade tornar-se-à nula também depois de reparações realizadas por oficinas não autorizadas pela GARDENA. Esta restrição valerá também para peças adicionais e acessórios.</p> |
| <p>DK <i>Produktansvar</i></p> | <p>Vi gør udtrykkeligt opmærksom på at i henhold til produktansvarsloven er vi ikke ansvarlige for skader forårsaget af vores udstyr, hvis det skyldes uautoriserede reparationer eller hvis dele er skiftet ud og der ikke er anvendt originale GARDENA dele eller dele godkendt af os, eller hvis reparationerne ikke er udført af GARDENA-service eller en autoriseret fagmand. Det samme gælder for ekstra udstyr og tilbehør.</p> |

| | |
|--|--|
| <p>D EG-Konformitätserklärung Der Unterzeichnete HUSQVARNA AB, GARDENA Manufacturing GmbH, Hans-Lorenser-Str. 40, D-89079 Ulm, bestätigt, dass die nachfolgend bezeichneten Geräte in der von uns in Verkehr gebrachten Ausführung die Anforderungen der harmonisierten EU-Richtlinien, EU-Sicherheitsstandards und produktspezifischen Standards erfüllen. Bei einer nicht mit uns abgestimmten Änderung der Geräte verliert diese Erklärung ihre Gültigkeit.</p> | <p>Bezeichnung des Gerätes: Teichschlammsauger Description of the product: Pond Silt Remover Désignation du matériel : Aspirateur de bassin Omschrijving van het apparaat: Vijvervuilzuiger Produktbeskrivning: Slamsugar för Damm Descrizione del prodotto: Pulitore per laghetti Descripción de la mercancía: Aspirador de lodo para estanque</p> |
| <p>GB EU Declaration of Conformity The undersigned HUSQVARNA AB, GARDENA Manufacturing GmbH, Hans-Lorenser-Str. 40, D-89079 Ulm, hereby certifies that, when leaving our factory, the units indicated below are in accordance with the harmonised EU guidelines, EU standards of safety and product specific standards. This certificate becomes void if the products are modified without our approval.</p> | <p>Descrição do aparelho: Aspirador de lodo de lago Beskrivelse af enhederne: Bassinstovsuger</p> |
| <p>F Certificat de conformité aux directives européennes Le constructeur, soussigné : HUSQVARNA AB, GARDENA Manufacturing GmbH, Hans-Lorenser-Str. 40, D-89079 Ulm, déclare qu'à la sortie de ses usines le matériel neuf désigné ci-dessous était conforme aux prescriptions des directives européennes énoncées ci-après et conforme aux règles de sécurité et autres règles qui lui sont applicables dans le cadre de l'Union européenne. Toute modification portée sur ce produit sans l'accord express de GARDENA supprime la validité de ce certificat.</p> | <p>Typ: Art.-Nr.: Type: Art. No.: Type : Référence : Typ: Art. nr.: Type: SR 1600 Art.nr.: 7946 Modello: Art. : Tipo: Art. N°: Tipo: Art. N°: Type: Varenr. :</p> |
| <p>NL EU-overeenstemmingsverklaring Ondergetekende HUSQVARNA AB, GARDENA Manufacturing GmbH, Hans-Lorenser-Str. 40, D-89079 Ulm, bevestigt, dat de volgende genoemde apparaten in de door ons in de handel gebrachte uitvoering voldoen aan de eis van, en in overeenstemming zijn met de EU-richtlijnen, de EU-veiligheidsstandaard en de voor het product specifieke standaard. Bij een niet met ons afgestemde verandering aan de apparaten verliest deze verklaring haar geldigheid.</p> | <p>EU-Richtlijnen: EU directives: 2006/95/EC Directives européennes : 2004/108/EC EU-richtlijnen: EU direktiv: 98/37/EC : 1998 Directive UE: 2006/42/EC : 2006 Normatieve UE: Directives da UE: 93/68/EC EU Retningslinier:</p> |
| <p>S EU Tillverkarintyg Undertecknad firma HUSQVARNA AB, GARDENA Manufacturing GmbH, Hans-Lorenser-Str. 40, D-89079 Ulm, intygar härmed att nedan nämnda produkter överensstämmer med EU:s direktiv, EU:s säkerhetsstandard och produktspecifikation. Detta intyg upphör att gälla om produkten ändras utan vårt tillstånd.</p> | <p>Hinterlegte Dokumentation: GARDENA Technische Dokumentation E. Renn 89079 Ulm Deposited Documentation: GARDENA Technical Documentation E. Renn 89079 Ulm Documentation déposée : Documentation technique GARDENA E. Renn 89079 Ulm</p> |
| <p>I Dichiarazione di conformità alle norme UE La sottoscritta HUSQVARNA AB, GARDENA Manufacturing GmbH, Hans-Lorenser-Str. 40, D-89079 Ulm, certifica che il prodotto qui di seguito indicato, nei modelli da noi commercializzati, è conforme alle direttive armonizzate UE nonché agli standard di sicurezza e agli standard specifici di prodotto. Qualunque modifica apportata al prodotto senza nostra specifica autorizzazione invalida la presente dichiarazione.</p> | <p>Anbringningsår der CE-Kennzeichnung: Year of CE marking: Date d'apposition du marquage CE : Installatiejaar van de CE-aanduiding: CE-Märkningsår: 2005 Anno di rilascio della certificazione CE: Colocación del distintivo CE: Ano de marcação pela CE: CE-Mærkningsår:</p> |
| <p>E Declaración de conformidad de la UE El que suscribe HUSQVARNA AB, GARDENA Manufacturing GmbH, Hans-Lorenser-Str. 40, D-89079 Ulm, declara que la presente mercancía, objeto de la presente de claración, cumple con todas las normas de la UE, en lo que a normas técnicas, de homologación y de seguridad se refiere. En caso de realizar cualquier modificación en la presente mercancía sin nuestra previa autorización, esta declaración pierde su validez.</p> | <p>Ulm, den 01.07.2007 Der Bevollmächtigte Ulm, 01.07.2007 Authorised representative Fait à Ulm, le 01.07.2007 Représentant légal Ulm, 01-07-2007 Gemachtigde Ulm, 2007.07.01. Behörig Firmatecknare Ulm, 01.07.2007 Rappresentante autorizzato Ulm, 01.07.2007 Representante autorizado Ulm, 01.07.2007 Representante autorizado Ulm, 01.07.2007 Teknisk direktør</p> |
| <p>P Certificado de conformidade da UE Os abaixo mencionados HUSQVARNA AB, GARDENA Manufacturing GmbH, Hans-Lorenser-Str. 40, D-89079 Ulm, por este meio certificam que ao sair da fábrica o aparelho abaixo mencionado está de acordo com as directrizes harmonizadas da UE, padrões de segurança e de produtos específicos. Este certificado ficará nulo se a unidade for modificada sem a nossa aprovação.</p> | <p> Peter Lameli Vice President</p> |
| <p>DK EU Overensstemmelse certificat Undertegnede HUSQVARNA AB, GARDENA Manufacturing GmbH, Hans-Lorenser-Str. 40, D-89079 Ulm bekræfter hermed, at enheder listet herunder, ved afsendelse fra fabrikken, er i overensstemmelse med harmoniserede EU retningslinier, EU sikkerhedsstandarder og produktspecifikationsstandarder. Dette certifikat træder ud af kraft hvis enhederne er ændret uden vor godkendelse.</p> | |

Deutschland / Germany

GARDENA GmbH
Central Service
Hans-Lorenser-Straße 40
D-89079 Ulm
Produktfragen:
(+49) 731 490-123
Reparaturen:
(+49) 731 490-290
service@gardena.com

Albania

EIG Sh.p.k - Rruga. Siri Kodra
Blloku i Magazinave
Frigoriferi Metalik Blu
4000 Tirana

Argentina

Husqvarna Argentina S.A.
Vera 745
(C1414AO) Buenos Aires
Phone: (+54) 11 4858-5000
diego.poggi@ar.husqvarna.com

Australia

GARDENA Australia Pty. Ltd.
Locked Bag 5
Central Coast BC, NSW 2252
Phone: (+61) (0) 2 4352 7400
customer.service@
husqvarna.com.au

Austria / Österreich

Husqvarna Austria GmbH
Consumer Products
Industriezeile 36
4010 Linz
Tel.: (+43) 732 77 01 01 - 90
consumer.service@husqvarna.at

Belgium

GARDENA Belgium NV/SA
Sterrebeekstraat 163
1930 Zaventem
Phone: (+32) 2 72 90 92
Mail: info@gardena.be

Bosnia / Herzegovina

SILK TRADE d.o.o.
Industrijska zona Bukva bb
74260 Tešanj

Brazil

Palash Comércio e
Importação Ltda.
Rua São João do Araguaia, 338
- Jardim Califórnia -
Barueri - SP - Brasil -
CEP 06409-060
Phone: (+55) 11 4198-9777
eduardo@palash.com.br

Bulgaria

Хукварна България ЕООД
Бул. „Андрей Ляпчев“ № 72
1799 София
Тел.: (+359) 02/975 3076
www.husqvarna.bg

Canada / USA

GARDENA Canada Ltd.
100 Summerlea Road
Brampton, Ontario L6T 4X3
Phone: (+1) 905 792 9330
info@gardenacanada.com

Chile

Antonio Martinic y Cia Ltda.
Cassillas 272
Centro de Cassillas
Santiago de Chile
Phone: (+56) 2 20 10 708
garfar_ci@yahoo.com

Costa Rica

Compania Exim
Euroiberioamericana S.A.
Los Colegios, Moravia,
200 metros al Sur del Colegio
Saint Francis - San José
Phone: (+506) 297 68 83
exim_euro@racsa.co.cr

Croatia

SILK ADRIA d.o.o.
Josipa Lončara 3
10090 Zagreb
Phone: (+385) 1 3794 580
silk.adria@zg.t-com.hr

CYPRUS

FARMOKIPIKI LTD
P.O. Box 7098
74, Digeni Akrita Ave.
1641 Nicosia
Phone: (+357) 22 75 47 62
condam@spidernet.com.cy

Czech Republic / Slovak Republic

Husqvarna Česko s.r.o.
odštěpný závod GARDENA
Tuřanka 1222/115
62700 Brno
Phone: (+420) 548 217 777
gardena@gardenabrno.cz

Denmark

GARDENA
Husqvarna Consumer Outdoor
Products
Salgsafdelning Danmark
Box 9003
S-200 39 Malmö
info@gardena.dk

Estonia

Husqvarna Eesti OÜ
Consumer Outdoor Products
Kesk tee 10, Aaviku küla
Rae vald
Harju maakond
75305 Estonia
kontakt.etj@husqvarna.ee

Finland

Oy Husqvarna Ab
Consumer Outdoor Products
Lautatarhankatu 8 B/PL 3
00581 HELSINKI
info@gardena.fi

France

GARDENA France
Immeuble Exposial
9 - 11 allée des Pierres Mayettes
ZAC des Barbanniers, B.P. 99
-F- 92232 GENNEVILLIERS
cedex
Tél. (+33) 01 40 85 30 40
service.consommateurs@
gardena.fr

Great Britain

Husqvarna UK Ltd
Preston Road
Aycliffe Industrial Park
Newton Aycliffe
County Durham
DL5 6UP
info.gardena@husqvarna.co.uk

Greece

HUSQVARNA ΕΛΛΑΣ Α.Ε.Β.Ε.
Υπ/μα Ηφαίστου 33Α
Βι. Πε. Κορωπίου
194 00 Κορωπί Αττικής
V.A.T. EL094094640
Phone: (+30) 210 66 20 225
info@husqvarna-consumer.gr

Hungary

Husqvarna Magyarországi Kft.
Ezred u. 1 - 3
1044 Budapest
Telefon: (+36) 1 251-4161
vevoszolgalat.husqvarna@
husqvarna.hu

Iceland

Ó. Johnson & Kaaber
Tunguhalsi 1
110 Reykjavik
oof@ojk.is

Ireland

McLoughlin's RS
Unit 5,
Northern Cross Business Park
North Road, Finglas
Dublin 11

Italy

GARDENA Italia S.p.A.
Via Santa Vecchia 15
23868 VALMADRERA (LC)
Phone: (+39) 0341.203.111
info@gardenaitalia.it

Japan

KAKUICHI Co. Ltd.
Sumitomo Realty &
Development Kojimachi
BLDG., 8F, 5-1 Nibanncyo,
Chiyoda-ku, Tokyo 102-0084
Phone: (+81) 33 264 4721
m_ishihara@kaku-ichi.co.jp

Latvia

Husqvarna Latvija
Consumer Outdoor Products
Bākūzu iela 6
LV-1024 Rīga
info@husqvarna.lv

Lithuania

UAB Husqvarna Lietuva
Consumer Outdoor Products
Ateities pl. 77C
LT-52104 Kaunas
centras@husqvarna.lt

Luxembourg

Magasins Jules Neuberg
39, rue Jacques Stas
Luxembourg-Gasperich 2549
Case Postale No. 12
Luxembourg 2010
Phone: (+352) 40 14 01
api@neuberg.lu

Netherlands

GARDENA Nederland B.V.
Postbus 50176
1305 AD ALMERE
Phone: (+31) 36 521 00 00
info@gardena.nl

Neth. Antilles

Jonka Enterprises N.V.
Sta. Rosa Weg 196
P.O. Box 8200, Curaçao
Phone: (+599) 9 767 66 55
pgm@jonka.com

New Zealand

Husqvarna New Zealand Ltd.
PO Box 76437
Manukau City 2241
Phone: (+64) (0) 9 9202410
support.nz@husqvarna.co.nz

Norway

GARDENA / Husqvarna
Consumer Outdoor Products
Salgskontor Norge
Kleiverveien 6
1540 Vestby
info@gardena.no

Poland

Husqvarna Poland Spółka z o.o.
ul. Wysockiego 15 b
03-371 Warszawa
Oddział w Szymanowie
Szymanów 9 d
05-532 Baniocha
Phone: (+48) 22 727 56 90
gardena@gardena.pl

Portugal

GARDENA Portugal Lda.
Sintra Business Park
Edifício 1, Fracção 0-G
2710-089 Sintra
Phone: (+351) 21 922 85 30
info@gardena.pt

Romania

Madex International Srl
Soseaua Odaii 117-123,
RO 013603, București, S 1
Phone: (+40) 21 352.76.03
madex@ines.ro

Russia

ООО „Хускварна“
141400, Московская обл.,
г. Химки,
улица Ленинградская,
владение 39,
Химки Бизнес Парк,
Здание II, 4 этаж.

Serbia

Domel d.o.o.
Savski nasip 7
11070 Novi Beograd
Phone: (+381) 11 2772 204
miroslav.jejina@domel.co.yu

Singapore

Hy - Ray PRIVATE LIMITED
40 Jalan Pemimpin
#02-08 Tat Ann Building
Singapore 577185
Phone: (+65) 6253 2277
shiyang@hyray.com.sg

Slovenia

GARDENA d.o.o.
Brodišče 15
1236 Trzin
Phone: (+386) 1 580 93 32
servis@gardena.si

South Africa

GARDENA
South Africa (Pty.) Ltd.
P.O. Box 11534
Vorna Valley 1686
Phone: (+27) 11 315 02 23
sales@gardena.co.za

Spain

GARDENA IBÉRICA S.L.U.
C/ Basauri, nº 6
La Florida
28023 Madrid
Phone: (+34) 91 708 05 00
atencioncliente@gardena.es

Sweden

GARDENA / Husqvarna
Consumer Outdoor Products
Försäljningskontor Sverige
Box 9003
200 39 Malmö
info@gardena.se

Switzerland / Schweiz

Husqvarna Schweiz AG
Consumer Products
Industriestrasse 10
5506 Mägenwil
Phone: (+41) (0) 848 800 464
info@gardena.ch

Turkey

GARDENA Dost Diş Ticaret
Müessesilik A.Ş.
Sanayi Cad. Adil Sokak
No: 1/B Kartal
34873 Istanbul
Phone: (+90) 216 38 93 939
info@gardena-dost.com.tr

Ukraine / Україна

ТОВ «Хусварна Україна»
вул. Васильківська, 34,
офіс 204-г
03022, Київ
Тел. (+38) 044 498 39 02
info@gardena.ua

7946-20.960.04/0310
© GARDENA
Manufacturing GmbH
D-89070 Ulm
http://www.gardena.com