

G X 5 6 0



Operator's Manual

Read the operator's manual carefully and make sure that you understand the contents before using the lawnmower.

Carton Contents

This product may have been purchased with a Wheel Assembly. Please assemble your product in accordance with the relevant instructions. Wheel Assembly Kits are available from your local stockists.

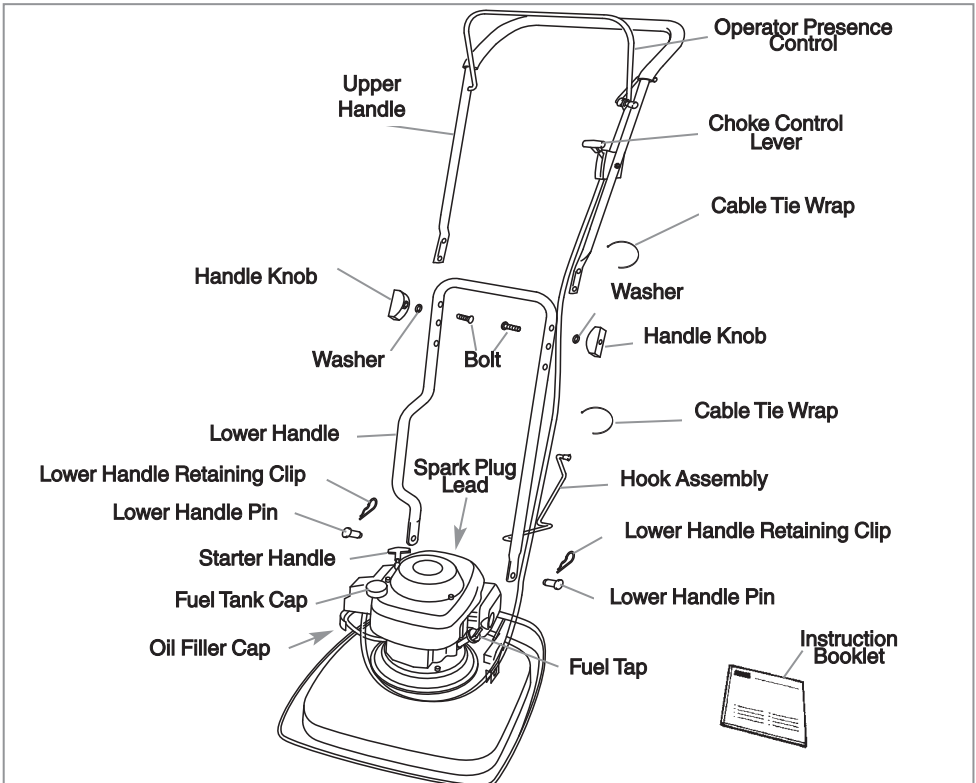

Wheel Frame (if applicable)

1. Lower Handle
2. Wheels x 2
3. Upper telescopic tubes
4. Telescopic tube pin
5. Telescopic tube retaining clip
6. Lower telescopic tubes
7. Wheel retaining clips
8. Wheel frame
9. Hook Assembly
10. Lower handle bolt x 2
11. Small washer x 2
12. Lower handle pin x 2
13. Large washer x 2
14. Locknut x 2

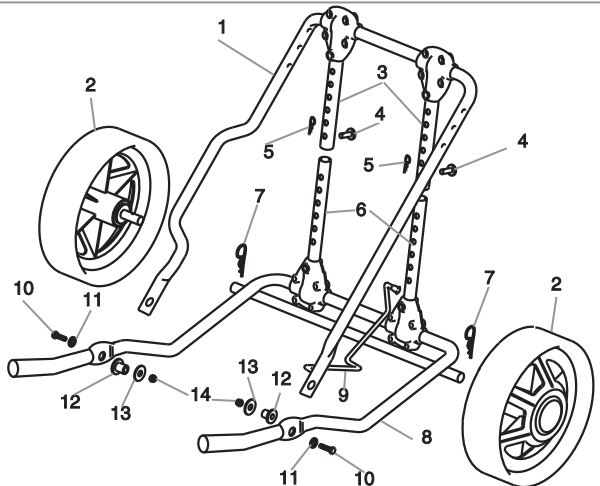

Safety



If not used properly this lawnmower can be dangerous! This lawnmower can cause serious injury to the operator and others, the warnings and safety instructions must be followed to ensure reasonable safety and efficiency in using this lawnmower. The operator is responsible for following the warning and safety instructions in this manual and on the lawnmower.

Explanation of Symbols on the GX560



Warning



Read the user instructions carefully to make sure you understand all the controls and what they do.



Always keep the lawnmower on the ground when mowing. Tilting or lifting the lawnmower may cause stones to be thrown out



Keep bystanders away. Do not mow whilst people especially children or pets are in the mowing area



Beware of severing toes or hands. Do not put hands or feet near a rotating blade.



Disconnect the spark plug before attempting any maintenance, cleaning or adjustment, or if you are going to leave the lawnmower unattended for any period.



Blade continues to rotate after the machine is switched off. Wait until all machine components have completely stopped before touching them.

General

- This product is not intended for use by persons (including children) with reduced physical, sensory or mental capabilities, or lack of experience and knowledge, unless they have been given supervision or instruction concerning the use of the product by a person responsible for their safety. Children should be supervised to ensure that they do not play with the product. Local regulations may restrict the age of the operator.
- Never allow children or people unfamiliar with these instructions to use the mower. Local regulations may restrict the age of the operator.
- Stop using the machine while people, especially children, or pets are nearby.
- Only use the lawnmower in the manner and for the functions described in these instructions.
- Never operate the lawnmower when you are tired, ill or under the influence of alcohol, drugs or medicine.
- The operator or user is responsible for accidents or hazards occurring to other people or their property.

Fuel Safety

Warning - Petrol is highly flammable

- Wear protective clothing when handling any fuels and lubricants.
- Avoid contact with skin. If affected, wash liberally with soap and water.
- Store fuel in a cool place in a container specifically designed for the purpose.
- Use a fresh, clean, unleaded regular automotive petrol
- Use 4-stroke automotive detergent oil. SAE 10W-30 is recommended for general use.
- Refuel outdoors only and do not smoke while refuelling.
- Wipe dirt and grass clippings from the fuel tank filler cap to avoid getting dirt into the fuel tank.
- Add fuel **BEFORE** starting the engine. Never remove the cap of the fuel tank or add fuel while the engine is running or when the engine is hot.
- If petrol is spilled, do not attempt to start the engine but move the machine away from the area of spillage and avoid creating any source of ignition until petrol vapours have dissipated.
- Never use stale fuel left from last season or fuel which has been stored for long periods.
- Replace all fuel tanks and container caps securely.
- Move the product away from the fuelling area before starting.
- Fuel should be stored in a cool place away from naked flames.
- Your carburettor is pre-set. Normally no further

adjustment is required.

Preparation

- While using your product always wear substantial footwear and long trousers. Do not operate the equipment when barefoot or wearing open sandals.
- The use of ear protection is recommended.
- Make sure the area to be cut is clear of sticks, stones, bones, wire and debris; they could be thrown by the blade.
- Before using the machine and after any impact, check for signs of wear or damage and repair as necessary.
- Replace worn or damaged blades together with their fixings in sets to preserve balance.
- Have faulty silencers replaced.

Use

- Do not operate the engine in a confined space where exhaust fumes (carbon monoxide) can collect.
- Use the mower only in daylight or good artificial light.
- Avoid operating your mower in wet grass, where feasible.
- Take care in wet grass, you may lose your footing.
- On slopes, be extra careful of your footing and wear non-slip footwear.
- Mowing on banks and slopes can be dangerous. Do not mow on **banks** or **steep** slopes.
- Do not walk backwards when mowing, you could trip. Walk never run.
- Never cut grass by pulling the mower towards you.
- Release the Operator Presence control to stop the engine before pushing the mower across surfaces other than grass and when transporting the lawnmower to and from the area to be mowed.
- Never operate the lawnmower with damaged guards or without guards in place.
- Do not overspeed the engine or alter governor settings. Excessive speed is dangerous and shortens lawnmower life.
- Keep hands and feet away from the blade at all times and especially when switching on the engine.
- Do not tilt the mower when starting the engine, except if the mower has to be tilted for starting. In this case, do not tilt more than absolutely necessary and lift only the part which is away from the operator. Always ensure that both hands are in the operating position before returning the appliance to the ground.
- Never pick up or carry a lawnmower while the engine is running
- Spark plug lead may be hot - handle with care.
- Do not attempt any maintenance on your lawnmower when the engine is hot.
- Release the Operator Presence Control, to stop the engine, and wait until the blade has stopped:
 - before leaving the mower unattended for any period.
- Release the Operator Presence Control, to stop the engine, wait until the blade has stopped, disconnect the spark plug lead and wait until the engine has cooled:-
 - before refuelling
 - before clearing a blockage;
 - before checking, cleaning or working on the appliance;
 - if you hit an object. Do not use your lawnmower until you are sure that the entire lawnmower is in a safe operating condition;
 - if the lawnmower starts to vibrate abnormally. Check immediately. Excessive vibration can cause injury.

Maintenance and storage

- Caution - Do not touch rotating blade.
- Keep all nuts, bolts and screws tight to be sure the lawnmower is in safe working condition.
- Replace worn or damaged parts for safety.
- Only use the replacement blade, blade bolt, spacer and impeller specified for this product.
- Never store the lawnmower with fuel in the tank inside a building where fumes can reach an open flame or spark.
- Allow the engine to cool before storing in any enclosure.
- To reduce fire hazard, keep the engine, muffler and fuel storage area free of grass, leaves or excessive grease.
- If the fuel tank has to be drained, this should be done outdoors.
- Be careful during adjustment of the machine to prevent entrapment of the fingers between moving parts and fixed parts of the machine.
- Store in a cool dry place and out of reach of children. Do not store outdoors.
- Allow the product to cool for atleast 30 minutes before storing.

Assembly (without wheels)

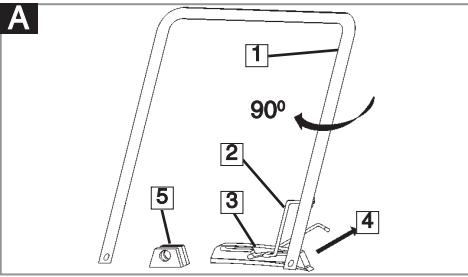

Fitting the Lower Handle to the Lawnmower

1. Feed the hook (A2) attached to the lower handle (A1) halfway through the centre slot of the guide (A3), in the direction indicated by the arrow (A4).
2. Maintaining the hook (A2) in the centre slot of the guide (A3) turn the lower handle (A1) clockwise through 90° to place both legs of the lower handle in position between the hood brackets (A5).
3. Insert the pins (B1) and secure with the retaining clips (B2).

Fitting the Upper Handle to the Lower Handle

BEFORE fitting the upper handle to the lower handle, stabilize the lower handle by lifting the hook (C1) to the 'parking' position (C2).

1. Ensure the Choke Control Lever is on the left hand side when viewed from the rear.
2. Align the lower and upper handle (See fig D). Locate the bolts (D1), washers (D2) and secure with the handle knobs (D3).
3. Fit the cables to the handles with the cable ties provided, making sure the cables are not trapped between the upper and lower handles.

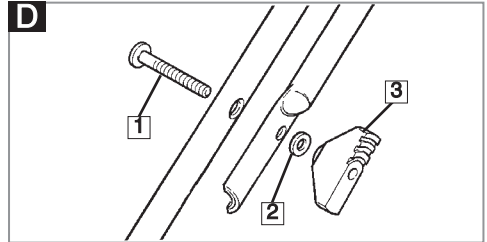
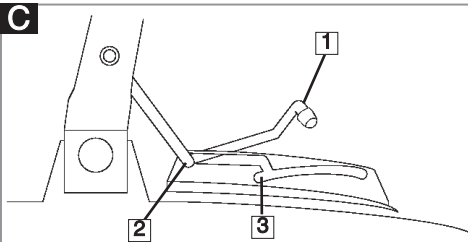
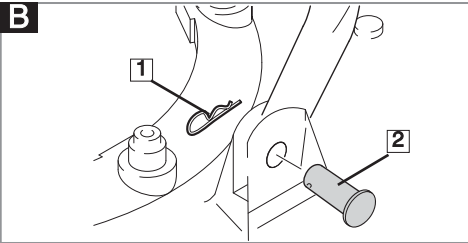

Assembly (with wheels)

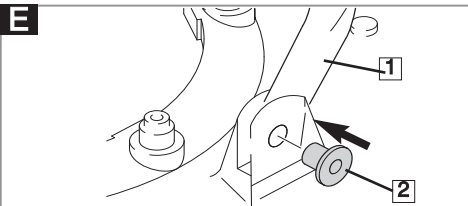

1. Fit the lower handle (E1) to the deck with the lower handle pin (E2) as illustrated in Fig E.
2. Attach the wheels (F1) to the wheel frame (F2) with the wheel retaining clips (F3) as illustrated in Fig F.
3. Fit the wheel frame (G1) to the deck with the lower handle bolt (G2), small washer (G3), large washer (G4) and locknut (G5) as illustrated in Fig G.
4. Locate the lower telescopic tubes (H1) inside the upper telescopic tubes (H2) and secure with the pin (H3) and retaining clip (H4) as illustrated in Fig H.

Fit the Upper Handle to the Lower Handle by following the instructions above in 'Assembly (without wheels)' section.

Handle Position

The handle position can be adjusted using the guide and hook assembly.

1. Lift hook (C1).
2. Position as required:
(C2) Parking position
(C3) Mowing position

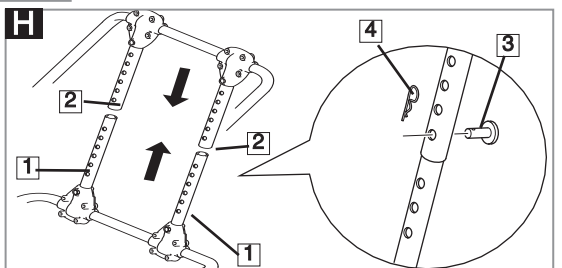
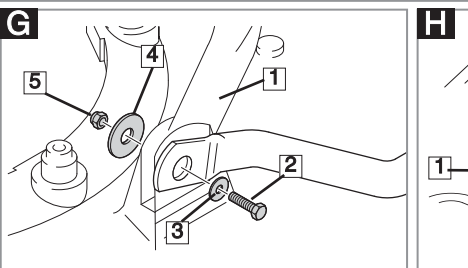
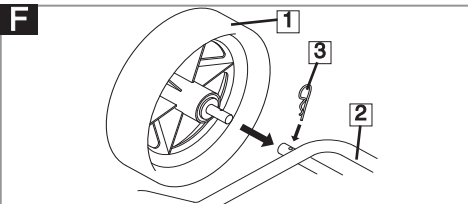

Fuel

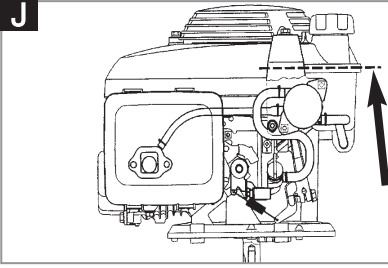

Use a fresh, clean, unleaded regular automotive gasoline. Do not fill the fuel tank in an enclosed area, when the engine is hot or while you are smoking or near a naked flame. Thoroughly clean around the fuel tank filler cap before filling, this will help to prevent dirt being introduced into the fuel system. Fuel should be stored in a cool place away from naked flames. Do not fill the tank while the engine is running. Fill the fuel tank through a funnel fitted with a fine filter. Never fill fuel tank completely, only fill to the base of the filler neck. When filling the fuel tank from empty, or when the engine has previously run dry, a minimum of 400cc of fuel must be added (to the level of the line indicated in diagram J) to ensure correct priming of the fuel pump to start the engine. Your carburettor is pre-set. Normally no further adjustment is required.

Oil

Use 4-stroke automotive detergent oil. SAE 10W-30 is recommended for general use.

Fill with oil as instructed in your Engine Owners Manual provided with your product.

Starting and Stopping

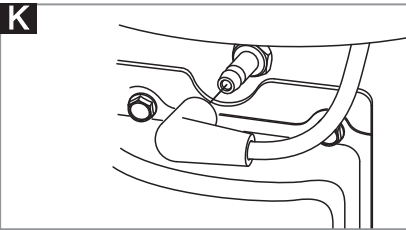

To Start your Lawnmower

1. Move the handle to the parking position (C2).
2. Connect the spark plug lead. (K).
3. Open the fuel tap (L).
4. Move the Choke control lever to the 'Choke' position (M) when starting from cold, and to the 'Run' position (N) when starting from hot.
5. Pull and firmly hold the Operator Presence Control to the upper handle.
6. Place your right foot firmly on the deck and grasp the top of the lower handle with your left hand. Tilt the trimmer towards you (P). This ensures the product is in a secure position when starting and also prevents an unsightly ring being cut in your lawn.
7. Pull the starting handle gently until you feel a resistance, return the starting handle slowly.
8. Pull the starting handle firmly towards you to its full extent.
9. Allow the engine to reach its full running speed then gently lower the lawnmower to the ground.
10. When the engine has warmed up make sure the choke control lever is in the 'Run' (N) position.

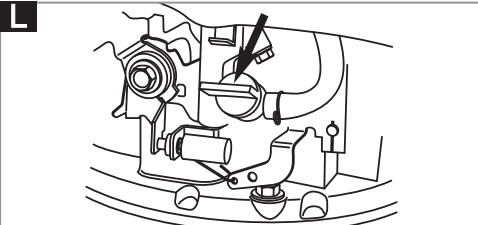

To Stop your Lawnmower

- Blade continues to rotate after the machine has switched off, rotating blades can cause injury.

1. Release the Operator Presence Control.
2. As the engine dies, tilt the lawnmower slightly. This prevents a ring being cut in your lawn.
3. When the engine has stopped, lower the lawnmower to the ground.
4. Put the handle in the Parking position (C2).
5. Close the fuel tap (L)

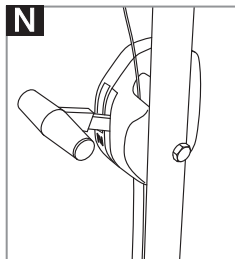
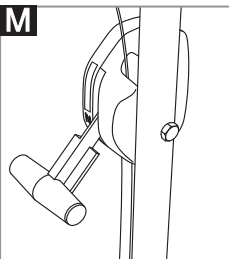

IMPORTANT

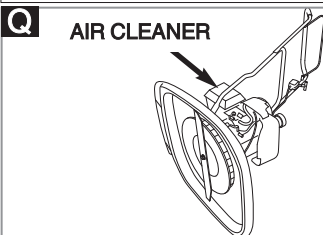

**TIP
THIS
WAY
ONLY**

Before any servicing to the underside of your machine, close the fuel tap, let the engine run until it stops, disconnect the spark plug lead and **TIP THE MACHINE ON ITS SIDE WITH THE AIR CLEANER UPPERMOST (Q).**

Adjusting the cutting height

Adjusting the Cutting Height

- **Never use more than 2 cutting height spacers.**
 - **Spacers can only be fitted between the blade and the fan and never between blade and the bolt (R).**
1. Ensure the Operator Presence Control is released, when the engine has stopped rotating - disconnect the spark plug lead.
 2. Close the fuel tap (L). Turn your lawnmower on its side.
 3. Remove the blade bolt (R1) and blade (R2) as described in 'Removing the Blade and Fan'.
 4. **For a Lower Cut - Add spacers (R3) to a maximum of 2.**
 5. **For a Higher Cut - Take spacers (R3) away.**
 6. Refit the blade as described in 'Fitting the Blade and Fan'.

How to Mow

1. Place the handle in the mowing position (C3).
 2. Mow twice a week in the growing season. Your lawn will suffer if more than one third of its length is cut at one time.
- **Keep hands and feet away from the blade, a rotating blade cannot be seen.**
 - **Mowing on banks and slopes can be dangerous. Do not mow on steep slopes.**
 - **Always keep your feet on flat ground with the mower below you on the slope and with the spark plug uppermost to avoid lubricating oil running into the cylinder.**
 - **Do not use this mower on slopes which are wet or more than 45° from horizontal.**
 - **Never push the mower up the slope.**

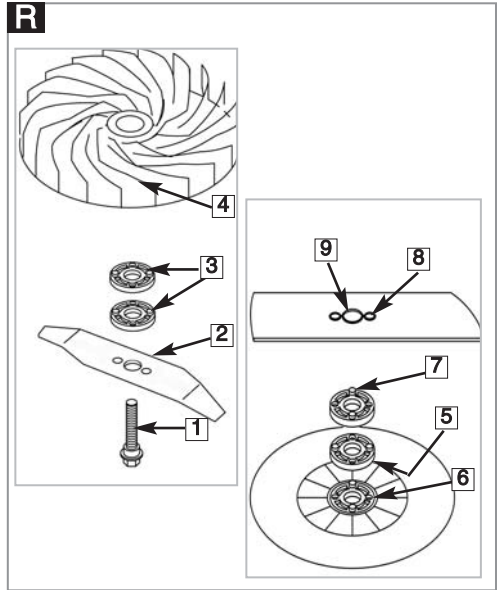

Removing & Fitting the Blade & Fan

WARNING

- **Always handle the blade with care - sharp edges could cause injury. USE GLOVES**
 - **Spark plug lead may be hot - handle with care.**
- ### Removing the Blade and Fan
- **Renew your metal blade after 50 hours mowing or 2 years whichever is the sooner - regardless of condition.**
 - **If the blade is cracked or damaged replace it with a new one.**

1. Ensure the Operator Presence Control is released, when the engine has stopped and the blade has stopped rotating - disconnect the spark plug lead.
2. Fully close the fuel tap (L).
3. Turn your lawnmower on its side with the air cleaner uppermost (see pic above).
4. To remove the blade bolt (R1), hold the fan (R4) firmly and with the spanner provided loosen the blade bolt by turning it anti-clockwise.
5. Remove the blade bolt (R1), spacers (R3) and fan (R4).
6. Inspect for damage and clean as necessary.

Fitting the Blade and the Fan

- **Before using the lawnmower, always visually inspect to see that blades and bolts are not worn or damaged.**
 - **Never use more than 2 cutting height spacers.**
 - **Spacers can only be fitted between the blade and the fan and never between blade and the bolt.**
1. Ensure the fan is located correctly.
 2. Place the spacers (R3) onto the fan ensuring the pegs (R5) have located into the holes (R6).
 3. Place the blade (R2) onto the spacers (R3) ensuring the pegs (R7) have located into the holes (R8) on the blade and ensuring the blade is positioned as illustrated in **Figure R**.
 4. Place the blade bolt (R1) through the centre hole (R9) of the blade.
 5. Tighten down clockwise by hand.
 6. Hold the fan firmly and tighten the blade bolt with the spanner provided.

Spark Plug

An oily or carboned spark plug makes starting difficult and decreases the efficiency of the engine. Periodically remove the spark plug and clean and adjust when necessary.

Gap setting 0.028 - 0.031".

Do not remove spark plug when engine is hot. Do not sand blast the spark plug to clean it.

Cleaning the Air Filter

Never run the engine without a filter or with a dirty filter. This will greatly reduce engine efficiency and lead to engine damage.

Your lawnmower is fitted with an Air Cleaner, the maintenance for which is as follows:-

- **Check the filter before each use.**
 - **Clean every 25 hrs or more frequently when used in dusty areas.**
 - **Replace filter every 200 hrs.**
1. Press the latch tabs on the top of the air cleaner cover and remove the cover.
 2. Check the filter is clean and in good condition.

If the filter is dirty:-

1. Tap the air filter several times on a hard surface to remove dirt, or blow compressed air through the air filter from the clean side that faces the engine. Never try to brush off dirt. Brushing will force dirt into the fibers.
3. Wipe dirt from the air cleaner body and cover using a moist rag. Be careful to prevent dirt from entering the air duct that leads to the carburetor.
4. Replace the filter and air cleaner cover.

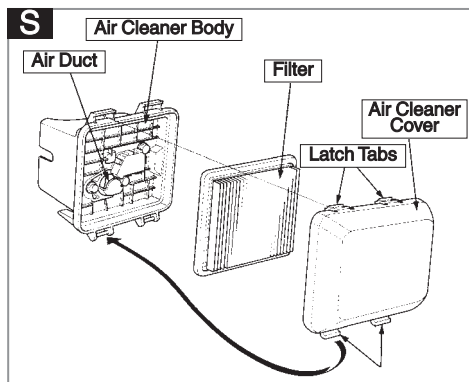

Caring for your Lawnmower

If you do not intend to use your lawnmower for long periods it is advisable to follow this procedure after use:

1. Stop the engine.
2. Fully close the fuel tap. (K)
3. Restart the engine.
4. As fuel runs out the engine will begin to stop, tilt the lawnmower slightly.
5. Once the engine has stopped, release the Operator Presence Control.
6. Disconnect the spark plug lead.
7. Remove all fuel from the fuel tank.

Cleaning - USE GLOVES

- **Keep your lawnmower clean - grass clippings left in any of the air intakes, around the engine or under the deck could become a potential fire hazard.**
 - **Do not clean with chemicals, including petrol, or solvents - some can destroy critical plastic parts.**
1. Remove grass from under the deck with a piece of wood or similar.
 2. Using a soft brush - remove grass clippings from around the engine and from all air intakes.
 3. Remove the fan, See '**Removing and Fitting the Blade and Fan**', and clean with a soft brush.
 4. Wipe over the surface of your lawnmower with a dry cloth.

Transporting your Lawnmower

- Turn the fuel tap to the off position and transport with the engine in a horizontal position.
- Never transport the lawnmower when it is running.

Storing Your Lawnmower

Turn the fuel tap to the off position and store in a cool, dry, damp-proof and safe place with the engine in a horizontal position. Service your lawnmower after the last cut of the year as follows:-

At the end of the Mowing Season

1. Stop the engine.
2. Fully close the fuel tap. (K)
3. Restart the engine.
4. As fuel runs out the engine will begin to stop, tilt the lawnmower slightly.
5. Once the engine has stopped, release the Operator Presence Control.
6. **Disconnect the spark plug lead.**
7. Remove all fuel from the fuel tank.
8. Remove the spark plug lead and spark plug. Pour one teaspoon (5ml) of oil through the spark plug hole. Pull the starting handle 2 or 3 times. This will distribute oil on the internal surfaces of the engine. Inspect, clean and replace the spark plug. If a new spark plug is required contact your local approved Husqvarna UK Ltd. Service Centre/Dealer. **Do not re-connect the spark plug lead.**
9. Clean the air filter. See '**Cleaning the Air Filter**'.
10. Renew the blade if it is cracked, damaged or bent. Renew the blade bolt if necessary. See '**Removing and Fitting the Blade and Fan**' for complete instructions.
11. Use only genuine Flymo parts and accessories specified for this product.
12. Clean your lawnmower thoroughly. See '**Cleaning**'.
13. Your local approved **Husqvarna UK Ltd. Service Centre/Dealer** will carry out any service or repairs required.
14. Store your lawnmower in a cool, dry, damp-proof and safe place.

Replacement Parts

Blade

Part no.:

5119004-00

Fault Finding

Engine Will Not Start

1. Ensure that the Operator Presence Control is gripped firmly to the upper handle.
2. Check that there is sufficient fuel in the fuel tank and the fuel tap is open
3. Check that the choke control lever is in the correct position:- 'Run' position **(N)** - for a hot engine, 'Choke' position **(M)** - for a cold engine.
4. The engine may have flooded. Remove and dry the spark plug.
5. Petrol may be stale, replace. Once the petrol has been replaced, it may take a little time for fresh petrol to filter through.
6. Check that the blade bolt is tight. A loose blade bolt could cause difficult starting.
7. **If the engine will still not start - disconnect the spark plug lead and consult you local approved Service Centre/Dealer.**

Poor Flotation or Lack of Power

1. Disconnect the spark plug lead.
2. Clean the underside of the hood, the air filter, the fan, around the engine and the air intakes.
3. Check that the engine choke control lever is in the 'Run' position. **(N)**
4. Petrol may be stale, replace. Once the petrol has been replaced, it may take a little time for fresh petrol to filter through.
5. **If poor flotation or lack of power persists - disconnect the spark plug lead and consult your local approved Service Centre/Dealer.**

Excessive Vibration

1. Disconnect the spark plug lead.
2. Check that the blade is correctly fitted. **'See 'Fitting and Removing the Blade and the Fan'.**
3. If the blade is damaged or worn, renew the blade.
4. **If vibration persists - do not use - disconnect the spark plug lead and consult your local approved Centre/Dealer.**

Service Recommendations

- **Your product is uniquely identified by a silver and black product rating label.**
- **We strongly recommend that your product is serviced at least every twelve months, more often in a professional application.**

Environmental Information

Husqvarna UK Ltd. are manufactured under an Environmental Management System (ISO 14001) using, where practical, components manufactured in the most environmentally responsible manner, according to company procedures, and with the potential for recycling at the end of the products' life.

- Packaging is recyclable and plastic components have been labelled (where practical) for categorised recycling.
- Awareness of the environment must be considered when disposing of 'end-of-life' product.
- If necessary, contact your local authority for disposal information.

DISPOSAL OF FUELS AND LUBRICATING OILS

- Wear protective clothing when handling any fuels and lubricants.
- Avoid contact with skin.
- Remove petrol and engine oil before transporting the product.
- Contact your local authority for information of your nearest Recycling/Disposal Station.
- **Do NOT dispose of used fuels/oils with household waste**
- **Do NOT dispose of used fuels/oils to water.**
- **Waste fuels/oils are harmful, but can be recycled and should be disposed of through the recognised facilities.**
- **Do NOT incinerate**

EC Declaration of Conformity

Husqvarna AB, 561 82, Huskvarna, Sweden

Declare under our sole responsibility that the product(s);

Category.....**Petrol Hover**
Model(s).....**GX560**
Identification of Series.....**See Product Rating Label**
Year of Construction.....**See Product Rating Label**

Complies with the essential requirements & provisions of the following EC Directives:
2006/42/EC, 2004/108/EC, 2000/14/EC
based on the following EU harmonized standards applied:
EN 836, EN55012

The maximum A weighted sound pressure level L^{pA} at the operator's position, recorded on a sample of the above product(s) corresponds to the **Level** given in the table.

The maximum hand / arm vibration weighted value measured according to EN ISO 5349 on a sample of the above product(s) corresponds to the **Value** a_h given in the table.

2000/14/EC: The Measured Sound Power L^{WA} & Guaranteed Sound Power L^{WA} values are according to the tabulated figures.

Conformity Assessment Procedure.....Annex VI
Notified Body.....Intertek, Cleeve Road
Leatherhead, Surrey
KT22 7SB, England

Newton Aycliffe, 13/04/2010
M. Bowden,
Research & Development Director
Husqvarna UK Ltd.
Keeper of technical documentation



Type	GX560
Width of Cut (cm)	50.5
Nominal Power (kW)	3.0
Measured Sound Power LWA (dB(A))	96
Guaranteed Sound Power LWA (dB(A))	98
Level (dB(A))	86.8
Uncertainty (dB(A))	2.5
Value a_h (m/s ²)	3.3
Uncertainty K of a_h (m/s ²)	1.5
Weight (Kg)	16.5

The power rating of the engine indicated is the average net power output (at specified rpm) of a typical production engine for the engine model measured to SAE standard J1349 / ISO 1585. Mass production engines may differ from this value. Actual engine power for the engine installed in the final machine will depend on the operating speed, environmental conditions and other variables.

Our policy of continuous improvement means that the specification of products may be altered from time to time without prior notice.

Copyright © 2008 Flymo S.A. All rights reserved. Flymo® and other product and feature names are registered or unregistered trademarks of Flymo S.A.

Husqvarna AB
561 82
Huskvarna
Sweden

