

AccuCut 400 Li
Art. 8840

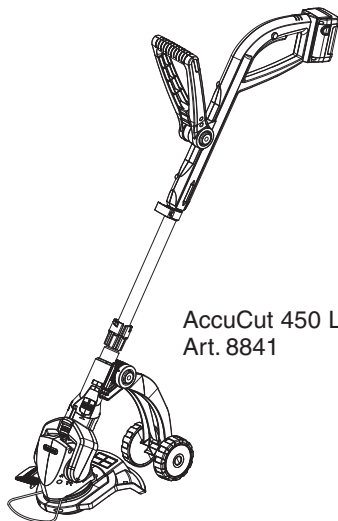

AccuCut 450 Li
Art. 8841

D Betriebsanleitung
Turbotrimmer

GB Operating Instructions
Turbotrimmer

F Mode d'emploi
Coupe bordures

NL Instructies voor gebruik
Turbotrimmer

S Bruksanvisning
Turbotrimmer

DK Brugsanvisning
Turbotrimmer

FIN Käyttöohje
Turbotrimmeri

N Bruksanvisning
Turbotrimmer

I Istruzioni per l'uso
Turbotrimmer

E Manual de instrucciones
Turbotrimmer

P Instruções de utilização
Turbotrimmer

PL Instrukcja obsługi
Podkaszarka żyłkowa

H Használati utasítás
Damilos fűszegélynyíró

CZ Návod k použití
Turbotrimmer

SK Návod na použitie
Turbotrimmer

GR Οδηγίες χρήσεως
Κοιρευτικό πετονιάς

RUS Инструкция по эксплуатации
Турботриммер

SLO Navodilo za uporabo
Kosilnica z nitko

HR Upute za uporabu
Turbo nitne kosilice

SRB Uputstvo za rad
Turbo trimmer-kosilica

UA Інструкція з експлуатації
Турботриммер

RO Instrucțiuni de utilizare
Turbotrimmer

TR Kullanım Klavuzu
Misinalı Ot Kesici

BG Инструкция за експлоатация
Турбо-тример

AL Manual përdorimi
Prerëse bari

EST Kasutusjuhend
Turbotrimmer

LT Eksploatavimo instrukcija
Turbo žoliapjovė

LV Lietošanas instrukcija
Turbo trimmeris

GARDENA Turbotrimmer

AccuCut 400 Li / AccuCut 450 Li

Welcome to the Garden of GARDENA...



Translation of the original instructions from German.
Please read these operating instructions carefully and observe the information they contain. Use these operating instructions to familiarise yourself with the GARDENA Turbotrimmer, its proper use and the notes on safety.



For safety reasons, children under the age of 16 as well as people who are not familiar with the operating instructions, should not use the Turbotrimmer. Persons with reduced physical or mental abilities may use the product only if they are supervised or instructed by a responsible person.

→ Please keep these operating instructions in a safe place.

Contents

1. Where to Use Your GARDENA Turbotrimmer	12
2. Safety Instructions	12
3. Assembly	14
4. Initial Operation	15
5. Operation	15
6. Storage	17
7. Maintenance	18
8. Troubleshooting	18
9. Accessories	19
10. Technical Data	20
11. Service / Warranty	20

1. Where to Use Your GARDENA Turbotrimmer

Proper use

The GARDENA Turbotrimmer is designed for trimming and cutting areas of grass and lawns in private house and hobby gardens. The Turbotrimmer must not be used in public facilities, parks, sports grounds, next to roads or in agriculture or forestry.

Please note



For safety reasons, the GARDENA Turbotrimmer must not be used for hedge trimming or for shredding for composting.

2. Safety Instructions

→ Please read the notes on safety on the Trimmer.



CAUTION !
→ Always read the operating instructions before using your Turbotrimmer.



DANGER !
Risk of injury to other people!
→ Keep other people out of the area where you are working.



DANGER !
→ Keep your Turbotrimmer away from water and rain!



DANGER !
Risk of injury to eyes!
→ Always wear eye protection!



DANGER! Tool does not stop immediately when turned off!

- Keep your hands and feet out of the area where you are working until the cutting filament is stationary!

Check your Trimmer before each use

- Always visually inspect your Trimmer before each use.
- Check that the ventilation slots are not obstructed in any way.

Do not use Trimmer when safety devices (starting lock-out, start button, safety cover) and/or blade are damaged or worn.

- Never bypass the safety devices.
- Inspect the area to be cut before you begin work. Remove any foreign objects and look out for foreign objects (such as stones, pieces of wood, strings and wires) while you are working.
- If you should come across an obstacle while cutting, turn off the Trimmer. Remove the object and check the Trimmer for any damage. If necessary have your Trimmer repaired.

Use / responsibility

The Trimmer can cause serious injuries.

- Use the Trimmer only for the purpose specified in these operating instructions.
- You are responsible for the safety in the area where you are working.
- Ensure that there are no other people (especially children) or animals within or near the area where you are working.
 - Never use the Trimmer if the safety devices are damaged or defective.

After use, regularly check Trimmer – in particular the blade – for damage and repair as appropriate.

- Always wear an eye shield or safety goggles!
- Wear sturdy shoes and long trousers to protect your legs. Keep fingers and feet away from blade – in particular with initial operation!
- Always ensure that you have a secure foothold whilst working.

Take extra care when walking backwards. You may stumble!

- Only work in the daylight or when visibility is good.



DANGER!
Personal injury and damage to property!

- Keep hands and feet away from blades, especially when Trimmer is switched on!

The Trimmer should only be used with the blade carrier also supplied and original GARDENA Spare Blades.

Interrupting work

Never leave the Trimmer unattended where you are working.

- If you stop work, store your Trimmer in a safe place.
- If you stop work in order to move to another part of the garden, always switch off the Trimmer and wait until the blade stops.

Familiarise yourself with the surroundings

- Familiarise yourself with the surroundings and look out for possible dangers which you may not hear due to machine noise.
- Never use the Turbotrimmer when it is raining or in damp, wet areas.

Battery safety



FIRE RISK!

- Never charge the batteries near acids or easily inflammable materials.

Only use the original GARDENA Battery Charger for charging. The use of other battery chargers may damage the batteries irreparably and even cause a fire.



RISK OF EXPLOSION!

- Protect Accu Trimmer from heat and fire.

Do not leave on radiators or expose to strong sunshine for long periods.

Only use your Accu Trimmer in an ambient temperature between -10°C and $+45^{\circ}\text{C}$.

The charging cable should be checked regularly for signs of damage or ageing (brittleness) and may only be used if it is in perfect condition.

The charger unit provided may only be used to charge the rechargeable batteries supplied with the Turbotrimmer.

Non-rechargeable batteries must not be charged with this battery charger (danger of fire).

Only charge battery between 10 – 45 °C. After heavy duty service allow battery to cool down first.

Storage:

The trimmer must not be stored over 35 °C or under direct exposure to sunlight.

Do not store the trimmer in places with static electricity.

3. Assembly

Assembling the trimmer:

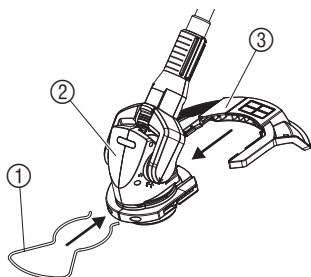

1. Push the cover ③ into the guide of the cutting head from behind ② until the connection locks into place on both sides.
2. Push plant guard ① onto the cutting head from the front ② until it locks into place.

Fit magazine for spare blades:

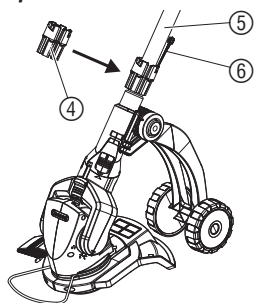

20 plastic blades and a magazine for spare blades are supplied with your trimmer. Up to 6 spare blades can be stored in the magazine.

1. Slightly widen magazine ④ at open point and slide onto handle ⑤.
2. Insert up to 6 plastic blades ⑥ in the magazine ④ until the blades jam.

To fit blade into blade carrier see 8. Troubleshooting "Replacing blades".

Fit additional wheel:

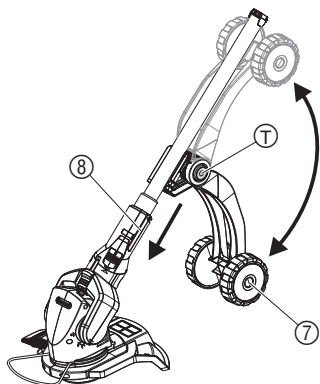

The additional wheel is available as an optional extra for the AccuCut 400 Li. The additional wheel is already fitted on the AccuCut 450 Li.

Fit additional wheel:

→ Fit additional wheel ⑦ onto the guides of the handle holder ⑧ until you hear the connection lock into place on both sides.

Remove additional wheel:

→ Pull both catches ⑨ out to the side and remove the additional wheel ⑦ from the guides of the handle holder ⑧.

Fold additional wheel up / down:

→ Press adjusting buttons ⑩ on both sides, fold additional wheel up / down ⑦ and release the adjustment buttons ⑩ again.

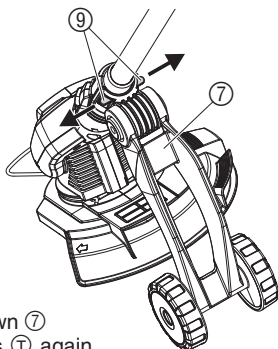

4. Initial Operation

Charging the battery:

Before using for the first time, the battery must be fully charged. Charging time (for uncharged battery) approx. 3 hrs.

The lithium-ion battery can be charged in any state of charge, and the charging process can be interrupted at any time without harming the battery (no memory effect).

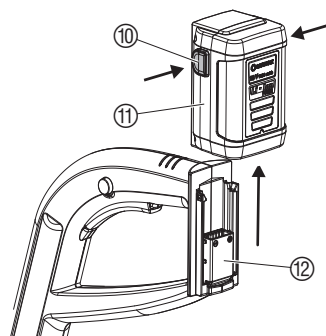

WARNING !
Overvoltage damages batteries and the battery charger.
 → **Ensure the correct mains voltage.**

1. Press the locking buttons in ⑩ and remove the battery ⑪ from the upper part of the handle ⑫.
2. Plug the plug of the charger cable ⑬ into the battery ⑪.
3. Plug battery charger ⑭ into a mains socket.
The charging indicator lamp ⑮ on the battery charger lights up red. The battery is being charged.

When the charging indicator lamp ⑮ lights up green, the battery is fully charged.

4. First remove the charging cable from the charging socket and then unplug the battery charger from the mains socket.
5. Push the battery ⑪ down onto the upper part of the handle ⑫.

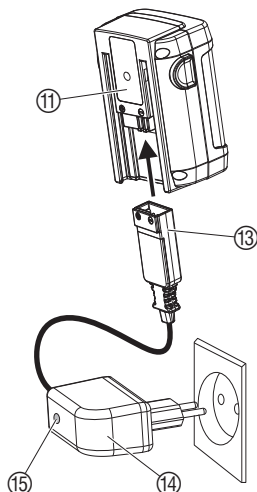

Avoid exhaustive discharge:

Do not wait until the blade comes to an absolute stop (battery totally discharged) as this shortens the battery life.

→ If the output of the trimmer decreases noticeably, charge the battery.

If the battery has been totally discharged, the LED will flash at the start of charging. If the LED is still flashing after an hour, a fault has occurred (see 8. Troubleshooting).

5. Operation

RISK OF INJURY !



Risk of injury if the Turbotrimmer does not switch off when you release the start button.

→ **Never bypass the safety devices (by binding the start button to the handle, for example).**

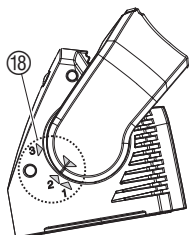
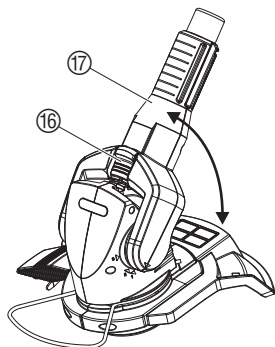
Setting the working position:

ATTENTION !
Overloading of the motor.

→ When trimming with wheels, working position 2 must be set.



Working position 1:
Trimming without wheels

Working position 2:
Trimming with wheels

Working position 3:
Trimming under obstacles

The angle of the handle can be set to 3 working positions.

1. Push slider 16 up and set the handle 17 to the required working position (see scale 18).
2. Let the slider 16 lock into the required working position.

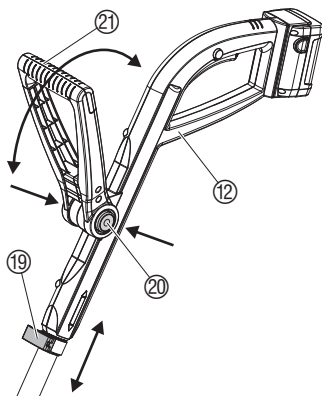
Setting the trimmer to body height:**Setting the handle length:**

→ Open clamping lever 19, extend upper part of handle 12 to required handle length and close clamping lever 19 again.

ATTENTION ! With AccuCut 400 Li, ensure that when adjusting the handle length the upper part of the handle 12 is not twisted.

Adjusting the additional handle:

→ Press adjusting buttons in 20 on both sides, set additional handle 21 to required angle and release the adjusting buttons 20 again.

When the trimmer is set to the correct body size, the body is upright and the cutting head is angled slightly forwards in working position.

→ Hold the trimmer on the upper part of the handle 12 and additional handle 21 in such a way that the cutting head is angled forwards slightly.

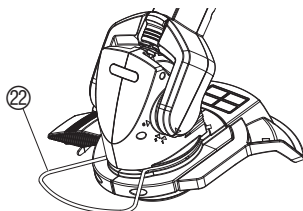
Adjusting the plant guard:

Working position

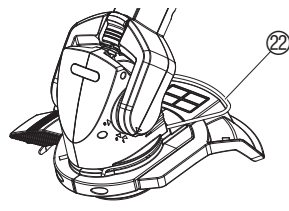

Parking position

→ Turn plant guard 22 through 180° into the required position until it locks into place.

Trimming overhanging lawn edges:



AccuCut 450 Li:

1. Setting the plant guard ② to parking position (see "Adjusting the plant guard").
2. Set handle angle to position 3 (see "Setting the working position").
3. Push slider ②③ upwards, turn handle ②④ through 90° and let slider ②③ lock into place (see arrows ⑤ on articulated fork and handle holder).

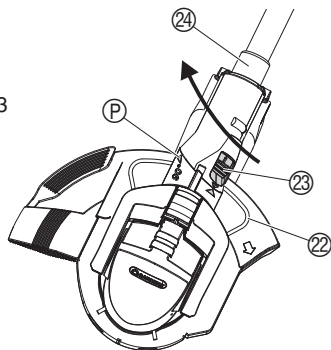

AccuCut 400 Li:

- Open clamping lever ⑱, turn upper part of handle ⑫ through 180° and close clamping lever ⑱ again.

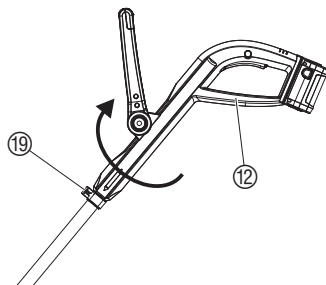

Starting the trimmer:

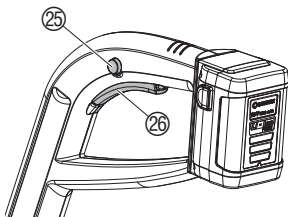

Switching the trimmer on:

1. Press and hold the safety lock ⑳ and then press the start button ㉑ on the handle.
2. Release the safety lock ⑳ again.

Switching the trimmer off:

- Release the start button ㉑ on the handle.

6. Storage

Storage:

The Turbotrimmer must be stored out of the reach of children.

1. Clean Trimmer (see 7. Maintenance).
2. Remove blade from blade carrier for storage (see 8. Troubleshooting).
3. Charging the battery (see 4. Initial Operation).
4. Store the Trimmer in a dry place protected from frost.

Recommendation:

The trimmer can be hung up by the handle. The cutting head is not put under any unnecessary strain if the trimmer is stored hanging up.

Disposal:

(in accordance with
RL2002/96/EC)



The product must not be added to normal household waste. It must be disposed of in line with local environmental regulations.

→ Important: Make sure that the unit is disposed of via your municipal recycling collection centre.

Disposal of batteries:

The GARDENA Accu-Trimmer contains lithium-ion batteries that should not be discarded with normal household waste at the end of their life.

Important:

Please return the lithium-ion batteries to your GARDENA dealer or dispose of them properly at a public recycling centre.

1. Discharge lithium-ion cells completely.
2. Dispose of lithium-ion cells properly.

7. Maintenance

DANGER!
Risk of injury!



Risk of injury from blade!
→ Do not switch Trimmer on for maintenance!

CAUTION!



Risk of injury and risk of damage to property!
→ Never clean the Turbotrimmer under running water or with a water jet (in particular a high pressure water jet).

Cleaning the cover and ventilation slots:

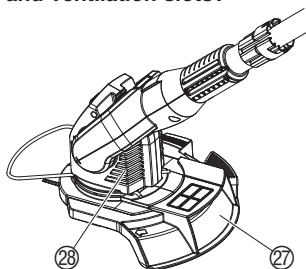

The ventilation slots must always be free of dirt.

→ Remove any grass and dirt from the cover ②⑦ and ventilation slots ②⑧ after each use.

8. Troubleshooting

DANGER!
Risk of injury!



Risk of injury from blade!
→ Do not switch Trimmer on for troubleshooting!

Replacing blades:



DANGER! Risk of injury!
→ Never use metal cutting elements or spare parts and accessories not intended for use by GARDENA.

Replacing blades:

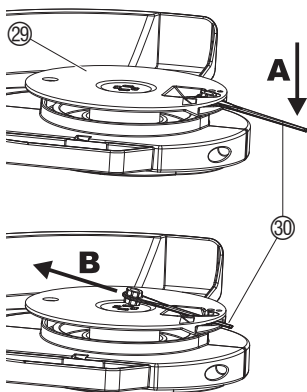

Only use original GARDENA Spare Blades. Spare blades are available from your GARDENA dealer or direct from GARDENA Service.

- GARDENA Spare Blades for Turbotrimmer AccuCut 400 Li / AccuCut 450 Li **Art. No. 5368**

Remove blade:

1. Turn Trimmer round and place on rubber pad of handle.
2. Press end of blade down slightly **(A)**, slide blade ③① inside through blade carrier ②⑨ **(B)** and pull out.

Fit blade:

- Slide new blade ③① from inside through slot in metal of blade carrier ②⑨ until it snaps into place.

When the new blade is correctly inserted, it can be moved more easily.

Fault	Possible cause	Remedy
The Trimmer is not cutting cleanly or not cutting at all	Blade worn or too short.	→ Replace blade.
	Blade broken off.	→ Replace blade.
	Battery is flat.	→ Charge battery.
Charging indicator lamp does not light up	Battery charger or charging cable not plugged in properly.	→ Plug in battery charger and charging cable properly.
Charging indicator lamp flashes for more than 1 hour	A fault has occurred. If this does not eliminate the fault, please contact GARDENA Service.	→ Unplug and reinsert charging cable. <i>The fault will be reset.</i>
The battery can no longer be charged	Battery is defective. Only the original GARDENA Replacement Battery 18 V (Art. No. 8839) may be used. This can be obtained from your GARDENA dealer or directly from GARDENA Service.	→ Replace the battery (Art. No. 8839).



In the event of other faults please contact GARDENA Service. Repairs should only be carried out by GARDENA service centres or dealers authorised by GARDENA.

9. Accessories

GARDENA Spare Blades	Art. No. 5368
GARDENA Replacement Battery	Art. No. 8839
GARDENA Additional wheel for AccuCut 400 Li	Art. No. 5310

10. Technical Data

Turbotrimmer	AccuCut 400 Li (Art. 8840)	AccuCut 450 Li (Art. 8841)
Cutting width	230 mm	230 mm
Weight	approx. 2.4 kg	approx. 2.8 kg
Rpm of blade carrier	approx. 9,000 rpm	approx. 9,000 rpm
Work area related emission characteristic value $L_{pA}^{1)}$		85 dB (A)
Noise level $L_{WA}^{2)}$	measured 83 dB (A) guaranteed 84 dB (A)	measured 84 dB (A) guaranteed 86 dB (A)
Hand/arm vibration $a_{vhw}^{1)}$	< 2.5 m/s ²	< 2.5 m/s ²
Battery	lithium ion (18V)	lithium ion (18V)
Battery capacity	1.6 Ah	1.6 Ah
Battery charging time	lithium ion 3 hrs	lithium ion 3 hrs
Idling time	approx. 40 mins (with full battery)	approx. 40 mins (with full battery)
Battery charger		
Mains voltage	230 V/ 50 Hz	230 V/ 50 Hz
Rated output current	600 mA	600 mA
Max. output voltage	21 V (DC)	21 V (DC)

Measuring method according to 1) EN 786 2) directive 2000/14/EC

11. Service / Warranty

GARDENA guarantees this product for 2 years (from date of purchase). This guarantee covers all serious defects of the unit that can be proved to be material or manufacturing faults. Under warranty we will either replace the unit or repair it free of charge if the following conditions apply:

- The unit must have been handled properly and in keeping with the requirements of the operating instructions.
- Neither the purchaser or a non-authorized third party have attempted to repair the unit.

The slide blade and the blade carrier are consumables and are not covered by the guarantee.

This manufacturer's guarantee does not affect the user's existing warranty claims against the dealer/seller.

If a fault occurs with your Turbotrimmer, please return the faulty unit together with a copy of the receipt and a description of the fault, with postage paid to one of the GARDENA Service Centres listed on the back of these operating instructions.

D Produkthaftung

Wir weisen ausdrücklich darauf hin, dass wir nach dem Produkthaftungsgesetz nicht für durch unsere Geräte hervorgerufene Schäden einzustehen haben, sofern diese durch unsachgemäße Reparatur verursacht oder bei einem Teileaustausch nicht unsere Original GARDENA Teile oder von uns freigegebene Teile verwendet werden und die Reparatur nicht vom GARDENA Service oder dem autorisierten Fachmann durchgeführt wird. Entsprechendes gilt für Ergänzungsstücke und Zubehör.

GB Product Liability

We expressly point out that, in accordance with the product liability law, we are not liable for any damage caused by our units if it is due to improper repair or if parts exchanged are not original GARDENA parts or parts approved by us, and, if the repairs were not carried out by a GARDENA Service Centre or an authorised specialist. The same applies to spare parts and accessories.

F Responsabilité

Nous vous signalons expressément que GARDENA n'est pas responsable des dommages causés par ses appareils, dans la mesure où ces dommages seraient causés suite à une réparation non conforme, dans la mesure où, lors d'un échange de pièces, les pièces d'origine GARDENA n'auraient pas été utilisées, ou si la réparation n'a pas été effectuée par le Service Après-Vente GARDENA ou l'un des Centres SAV agréés GARDENA. Ceci est également valable pour tout ajout de pièces et d'accessoires autres que ceux préconisés par GARDENA.

NL Productaansprakelijkheid

Wij wijzen er nadrukkelijk op, dat wij op grond van de wet aansprakelijkheid voor producten niet aansprakelijk zijn voor schade ontstaan door onze apparaten, indien deze door onvakkundige reparatie veroorzaakt zijn, of er bij het uitwisselen van onderdelen geen gebruik gemaakt werd van onze originele GARDENA onderdelen of door ons vrigegeven onderdelen en reparatie niet door de GARDENA technische dienst of de bevoegde vakman uitgevoerd werd. Ditzelfde geldt voor extra-onderdelen en accessoires.

S Produktansvar

Tillverkaren är inte ansvarig för skada som orsakats av produkten om skadan beror på att produkten har reparerats felaktigt eller om, vid reparation eller utbyte, andra än Original GARDENA reservdelar har använts. Samma sak gäller för kompletteringsdelar och tillbehör.

DK Produktansvar

Vi gør udtrykkeligt opmærksom på at i henhold til produktansvarsloven er vi ikke ansvarlige for skader forårsaget af vores udstyr, hvis det skyldes uautoriserede reparationer eller hvis dele er skiftet ud og der ikke er anvendt originale GARDENA dele eller dele godkendt af os, eller hvis reparationerne ikke er udført af GARDENA-service eller en autoriseret fagmand. Det samme gælder for ekstra udstyr og tilbehør.

FIN Tuotevastuu

Korostamme nimenomaan, että tuotevastuulain nojalla emme ole vastuussa laitteistamme johtuneista vahingoista, mikäli nämä ovat aiheutuneet epäasianmukaisesta korjauksesta tai osia vaihdettaessa ei ole käytetty alkuperäisiä GARDENA- varaosia tai hyväksymämme osia ja korjauksen on suorittanut muu kuin GARDENA -huoltokeskus tai valtuuttamamme ammattihenkilö. Tämä pätee myös lisäosiin ja lisävarusteisiin.

I Responsabilità del prodotto

Si rende espressamente noto che, conformemente alla legislazione sulla responsabilità del prodotto, non si risponde di danni causati da nostri articoli se originati da riparazioni eseguite non correttamente o da sostituzioni di parti effettuate con materiale non originale GARDENA o comunque da noi non approvato e, in ogni caso, qualora l'intervento non venga eseguito da un centro assistenza GARDENA o da personale specializzato autorizzato. Lo stesso vale per le parti complementari e gli accessori.

E Responsabilidad de productos

Advertimos que conforme a la ley de responsabilidad de productos no nos responsabilizamos de daños causados por nuestros aparatos, siempre y cuando dichos daños hayan sido originados por arreglos o reparaciones indebidas, por recambios con piezas que no sean piezas originales GARDENA o bien piezas autorizadas por nosotros, así como en aquellos casos en que la reparación no haya sido efectuada por un Servicio Técnico GARDENA o por un técnico autorizado. Lo mismo es aplicable para las piezas complementarias y accesorios.

P Responsabilidade sobre o produto

Queremos salientar que segundo a lei da responsabilidade do fabricante, nós não nos responsabilizaremos por danos causados pelo nosso equipamento, quando estes ocorrerem em decorrência de reparações inadequadas ou da substituição de peças por peças não originais da GARDENA, ou peças não autorizadas. A responsabilidade tornar-se-à nula também depois de reparações realizadas por oficinas não autorizadas pela GARDENA. Esta restrição valerá também para peças adicionais e acessórios.

<p>D EG-Konformit�tserkl�ring</p> <p>Der Unterzeichnete Husqvarna AB, 561 82 Huskvarna, Sweden best�tigt, dass die nachfolgend bezeichneten Ger�te in der von uns in Verkehr gebrachten Ausf�hrung die Anforderungen der harmonisierten EU-Richtlinien, EU-Sicherheitsstandards und produktspezifischen Standards erf�llen. Bei einer nicht mit uns abgestimmten �nderung der Ger�te verliert diese Erkl�rung ihre G�ltigkeit.</p>	<p>H EU azonosos�gi nyilatkozat</p> <p>Alulirott, Husqvarna AB, 561 82 Huskvarna, Sweden, igazolja, hogy az al�bb felsorolt, �ltalunk forgalomba hozott term�kek megfelelnek az EU elv�r�soknak, EU biztons�gi norm�knak �s a term�kspecifikus szabv�nyoknak egyar�nt. A k�szl�k vel�nk nem egyeztetett v�ltoztat�sa eset�n ez a nyilatkozat �rvenyt veszti.</p>
<p>GB EU Declaration of Conformity</p> <p>The undersigned Husqvarna AB, 561 82 Huskvarna, Sweden, hereby certifies that, when leaving our factory, the units indicated below are in accordance with the harmonised EU guidelines, EU standards of safety and product specific standards. This certificate becomes void if the units are modified without our approval.</p>	<p>CZ ES Prohl�sen� o shod�</p> <p>Ni�e podpevnasa spole�nost Husqvarna AB, 561 82 Huskvarna, Sweden, potvrzuje, �e ni�e ozna�en� p�stroj v provedeni, kter� jsmo uvedli na trh, spl�uje po�adavky uvedene v harmonizovan�ch sm�rnicech EU, v bezpe�nostn�ch standardech EU a ve standardech pro dan� produkt. V p�r�pad� zm�ny p�stroje, kter� n�mi nebyla odsouhlasena, ztr�ci toto prohl�sen� platnost.</p>
<p>F Certificat de conformit� aux directives europ�ennes</p> <p>Le constructeur, soussign� : Husqvarna AB, 561 82 Huskvarna, Sweden, d�clare qu'� la sortie de ses usines le mat�riel neuf design� ci-dessous �tait conforme aux prescriptions des directives europ�ennes �nonc�es ci-apr�s et conforme aux r�gles de s�curit� et autres r�gles qui lui sont applicables dans le cadre de l'Union europ�enne. Toute modification port�e sur ce produit sans l'accord express de Husqvarna supprime la validit� de ce certificat.</p>	<p>SK ES Vyhlasenie o zhode</p> <p>Dolu podpisan� spolo�nost Husqvarna AB, 561 82 Huskvarna, Sweden, potvrzuje, �e ďalej ozna�en� p�stroj vo vyhotoveni nami uvedenom do prev�dzky spl�va po�iadavky harmonizovan�ch smernic EU, bezpe�nostn�ch štandardov EU a štandardov špecifick�ch pre produkt. V p�r�pad� zmeny p�stroja, ktor� nebola nami odsuhlasen�, stráca toto vyhl�senie platnosť.</p>
<p>NL EU-overeenstemmingsverklaring</p> <p>Ondergetekende Husqvarna AB, 561 82 Huskvarna, Sweden, bevestigt, dat het volgende genoemde apparaat in de door ons in de handel gebrachte uitvoering voldoet aan de eis van, en in overeenstemming is met de EU-richtlijnen, de EU-veiligheidsstandaard en de voor het product specifieke standaard. Bij een niet met ons afgestemde verandering aan het apparaat verliest deze verklaring haar geldigheid.</p>	<p>GR Πιστοποιητικό συμφωνίας ΕΚ</p> <p>Η υπογεγραμμένη : Husqvarna AB, 561 82 Huskvarna, Sweden πιστοποιεί �τι τα μηχανήματα που υποδεικνύονται κάτωθι, �ταν φεγχουν �πο το εργοστάσιο, είναι κατασκευασμένα σύμφωνα με τις οδηγίες της Ευρωπαϊκής Κοινότητας, τα Κοινωνικά πρότυπα ασφαλείας και τις προδιαγραφές. Αυτό το πιστοποιητικό δεν ισχύει σε περίπτωση που τα προϊόντα τροποποιηθούν χωρίς την �γκρισή μας.</p>
<p>S EU Tillverkarintyg</p> <p>Undertecknad firma Husqvarna AB, 561 82 Huskvarna, Sweden, intygar h�rmed att nedan n�mnda produkter �verensst�mmer med EU:s direktiv, EU:s s�kerhetsstandard och produktspecifikation. Detta intyg upph�r att g�lla om produkten �ndras utan v�rt tillst�nd.</p>	<p>SLO Izjava o skladnosti s pravili EU</p> <p>Podpisano podjetje, Husqvarna AB, 561 82 Huskvarna, Sweden, potrjuje, da v nadaljevanju navedena naprava v razli�ci, ki smo jo poslali na trg, izpolnjuje zahteve smernic EU, varnostnih standardov EU in standardov tovrstnih proizvajalcev. Izjava ne velja za spremembe na napravi, ki niso opravljene v soglasju z nami.</p>
<p>DK EU Overensstemmelse certificat</p> <p>Undertegnede Husqvarna AB, 561 82 Huskvarna, Sweden bekr�fter hermed, at enheder listet herunder, ved afsendelse fra fabrikken, er i overensstemmelse med harmoniserede EU retningslinjer, EU sikkerhedsstandarder og produkt-specifikationsstandarder. Dette certificat tr�der ud af kraft hvis enhederne er �ndret uden vor godkendelse.</p>	<p>RO UE - Certificat de conformitate</p> <p>Prin prezenta Husqvarna AB, 561 82 Huskvarna, Sweden, certifica faptul ca, in momentul in care produsele mentionate mai jos ies din fabrica sunt in concordanta cu directivele UE, standardele de siguranta UE si standardele specifice ale produsului UE. Acest certificat devine nul in cazul modificarii aparatului f�r� aprobarea noastr�.</p>
<p>FIN EY-vaatimustenmukaisuusvakuutus</p> <p>Allerkirjoittanut Husqvarna AB, 561 82 Huskvarna, Sweden vakuuttaa, ett� allamainittu laitteet t�ytt�v�t tehtaaltamme l�htess�n yhdenmukaistettujen EY-direktiivien, EY-turvallisuusstandardien ja tuotekohtaisten standardien vaatimukset. Laitteisiin tehty muutokset, joista ei ole sovittu kanssamme, johtavat t�m�n vakuutuksen raukaamiseen.</p>	<p>BG ES-Декларация за съответствие</p> <p>Подписаната фирма Husqvarna AB, 561 82 Huskvarna, Sweden декларира, че описаните подолу уреди, пуснати в продажба съгласно нашата спецификация, изпълняват изискванията на хармонизираните ЕС-директиви, ЕС-станданти за безопасност и специфичните производствени стандарти. При промяна на уреда, която не е съгласувана с нас, тази декларация губи своята валидност.</p>
<p>I Dichiarazione di conformit� alle norme UE</p> <p>La sottoscritta Husqvarna AB, 561 82 Huskvarna, Sweden, certifica che il prodotto qui di seguito indicato, nei modelli da noi commercializzati, � conforme alle direttive armonizzate UE nonch� agli standard di sicurezza e agli standard specifici di prodotto. Qualunque modifica apportata al prodotto senza nostra specifica autorizzazione invalida la presente dichiarazione.</p>	<p>EST Eli vastavusdeklaratsioon</p> <p>Allkirjutatu Husqvarna AB, 561 82 Huskvarna, Sweden kinnitab, et kirjeldatud seade vastab meie poolt ringluse viidud kujul Eli harmoneeritud direktiividele, ELi ohutusstandarditele ja tootega seotud standarditele. Meiega koosk�lastamata muudatused tegemise korral seadmel kaotab see deklaratsioon kehtivuse.</p>
<p>E Declaraci�n de conformidad de la UE</p> <p>El que suscribe Husqvarna AB, 561 82 Huskvarna, Sweden, declara que la presente mercancia, objeto de la presente declaraci�n, cumple con todas las normas de la UE, en lo que a normas t�cnicas, de homologaci�n y de seguridad se refiere. En caso de realizar cualquier modificaci�n en la presente mercancia sin nuestra previa autorizaci�n, esta declaraci�n pierde su validez.</p>	<p>LT ES Atitikties deklaracija</p> <p>Pasirašanti Husqvarna AB, 561 82 Huskvarna, Sweden patvirtina, kad žemiau nurodyti prietaisai ir jų modeliai, kuriuos paleidome į apyvartą, patenkinia harmonizuotas ES direktyvas, ES saugumo standartus ir specifinius gaminio standartus. Atlikus bet kokį prietaiso pakeitimą, kuris nėra suderintas su mumis, ši deklaracija praranda galiojimą.</p>
<p>P Certificado de conformidade da UE</p> <p>Os abaixo mencionados Husqvarna AB, 561 82 Huskvarna, Sweden, por este meio certificam que ao sair da f�brica o aparelho abaixo mencionado est� de acordo com as diretrizes harmonizadas da UE, padr�es de seguran�a e de produtos espec�ficos. Este certificado ficar� nulo se a unidade for modificada sem a nossa aprova�o.</p>	<p>LV ES-atbilstības deklarācija</p> <p>Parakstījusies Husqvarna AB, 561 82 Huskvarna, Sweden, Vācija apstiprina, ka sekojoši apzīmētās iekārtas, kuras mēs izplatām, savā izpildījumā atbilst harmonizētajām ES direktīvām, ES drošības standartiem un produkta specifiskajiem standartiem. Ar mūsu neapstiprinātām izmaiņām iekārtā šī deklarācija zaudē savu derīgumu.</p>
<p>PL Deklaracja zgodności Unii Europejskiej</p> <p>Niżej podpisany Husqvarna AB, 561 82 Huskvarna, Sweden, potwierdza, że poniżej opisane urządzenie w wykonaniu wprowadzonym przez nas do obrotu spełnia wymogi zharmonizowanych wytycznych Unii Europejskiej, standardów bezpieczeństwa Unii Europejskiej i standardów specyficznych dla danego produktu. W przypadku wprowadzenia zmian nie uzgodnionych z nami wyjaśnienie to traci swoją ważność.</p>	

Bezeichnung des Gerätes: Turbotrimmer Description of the unit: Turbotrimmer Désignation du matériel : Taille-haies électrique Omschrijving van het apparaat: Turbotrimmer Produktbeskrivning: Turbotrimmer Beskrivelse af enhederne: Turbotrimmer Laitteiden nimitys: Turbotrimmeri Descrizione del prodotto: Turbotrimmer Descrição de la mercancia: Turbotrimmer Descrição do aparelho: Turbotrimmer Opis urządzenia: Podkaszarka żyłkowa A készőlék megnevezése: Damilos fűszegélynyíró Označení přístroje: Turbotrimmer Označenje prístroja: Turbotrimmer Ονομασία της συσκευής: Κοιρευτικό πετονιάς Označka naprave: Kosilnica z nitko Descrierea articolului: Turbotrimmeri Обозначение на уредите: Турбо-тримѐр Seadmete nimetus: Turbotrimmeri Gaminio pavadinimas: Turbo žoliapjovė Iekārtu apzīmējums: Turbo trimmeris	Schall-Leistungspegel: gemessen / garantiert Noise level: measured / guaranteed Puissance acoustique : mesurée / garantie Geluidsniveau: gemeten / gegarandeerd Ljudnivå: uppmått / garanterad Lydtryksniveau: afmålt / garanti Melun tehotas: mitattu / taattu Livello rumorosità: testato / garantito Nivel sonoro: medido / garantizado Nivel de ruído: medido / garantido Poziom hałas: zmierzony / gwarantowany Zajszint: mért / garantált Hladina hluku: naměřeno / zaručeno Výkonová úroveň hluku: meraná / zaručená Στάθμη ηχητικής πίεσης: μετρηθείσα / εγγυημένη Glasnost: izmerjeno / garantirano Nivelul de zgomot: măsurat / garantat Ниво на шума и мощността: измерено / гарантирано Helivõimsuse tase: mõõdetud / tagatud Garso galios lygis: išmatuotas / garantuotas Skaņas jaudas līmenis: izmērtais / garantētais
Typ: Τύπος: Art.-Nr.: Cikkszám: Type: Type: Art. No.: Č.výr: Type : Type: Référence : Č.výr: Typ: Τύπος: Art. nr.: Κωδ. No.: Type: Tip: Art.nr.: Št. art.: Type: Tipuri: Varen. : Nr art.: Tyyppi: Tyype: Art.-no.: Apt.-№ : Modello: Tüübid: Art. : Toote nr: Tipo: Tipas: Art. №: Gaminio Nr.: Tipo: Tipi: Art. №: Art.-Nr.: Type: Nr art.: AccuCut 400 Li 8840 AccuCut 450 Li 8841	AccuCut 400 Li 83 dB (A) / 84 dB (A) AccuCut 450 Li 84 dB (A) / 86 dB (A)
EU-Richtlinien: EU szabványok: EU directives: Směrnice EU: Directives européennes : Směrnice EU: EU-richtlijnen: Προδιαγραφές EK: EU direktiv: Směrnice EU: EU Retningslinier: Directive UE: EY-direktiivit: EC-директиви: Directive UE: EĽi direktiivid: Normativa UE: ES direktivos: Directrices da UE: ES-direktivas: Dyrektywy UE: 2004/108/EC 2006/42/EC 2000/14/EC 2006/95/EC 93/68/EC	Anbringningsjahr der CE-Kennzeichnung: CE bejegyzés kelté: Rok pridělení značky CE: Rok pridelenia označenia CE: Year of CE marking: Rok pridelenia označenia CE: Date d'apposition du marquage CE : Έτος πιστοποίησης ποιότητας CE: Installatiejaar van de CE-aanduiding: Leto namestitve oznake CE: CE-Märkningsår: Anul de marcare CE: CE-Mærkningsår: Година на поставяне на CE-маркировка: CE-merkin kiinnitysvoosi: CE-märgistuse paigaldamise aasta: Anno di rilascio della certificazione CE: CE- markējuma uzlikšanas gads: Colocación del distintivo CE: Metai, kuriais paženklinta CE-izkla: Ano de marcação pela CE: CE-izkla: Rok nadania znaku CE: 2008
Harmonisierte EN: EN ISO 12100-1 EN 60335-1 EN ISO 12100-2 EN 60335-2-91 EN 786 ISO 4871	Ulm, den 01.07.2008 Ulm, 01.07.2008 Fait à Ulm, le 01.07.2008 Ulm, 01-07-2008 Ulm, 2008.07.01. Ulm, 01.07.2008 Ulmissa, 01.07.2008 Ulm, 01.07.2008 Ulm, 01.07.2008 Ulm, 01.07.2008 Ulm, 01.07.2008 Ulm, 01.07.2008 V Ulmu, dne 01.07.2008 Ulm, 01.07.2008 Ulm, 01.07.2008 Ulm, 01.07.2008 Ulm, 01.07.2008 Ulm, 01.07.2008 Ulm, 01.07.2008 Ulm, 2008.07.01 Ulma, 01.07.2008
Hinterlegte Dokumentation: GARDENA Technische Dokumentation E. Renn 89079 Ulm Deposited Documentation: GARDENA Technical Documentation E. Renn 89079 Ulm Documentation déposée : Documentation technique GARDENA E. Renn 89079 Ulm Konformitätsbewertungsverfahren: Nach 2000/14/EG Art. 14 Anhang V Conformity Assessment Procedure: according to 2000/14/EC Art. 14 Annex V Procédure d'évaluation de la conformité : Selon 2000/14/CE art. 14 Annexe V	Der Bevollmächtigte Authorised representative Représentant légal Gemachtigde Behörig Firmatecknare Teknisk direktör Valtuutettu edustaja Rappresentante autorizzato Representante autorizado Representante autorizado Uprawniony do reprezentacji Meghatalmazott Zplnomocněnec Splnomocnenec Νόμιμος εκπρόσωπος της εταιρίας Vodja tehničnega oddelka Conducerea tehnică Упълномощен Volitatud esindaja Įgaliotasis atstovas Pilnvarotā persona  Peter Lameli Vice President

Deutschland / Germany

GARDENA GmbH
Central Service
Hans-Lorenser-Straße 40
D-89079 Ulm
Produktfragen:
(+49) 731 490-123
Reparaturen:
(+49) 731 490-290
service@gardena.com

Albania

COBALT Sh.p.k.
Rr. Siri Kodra
1000 Tirana
Argentina
Husqvarna Argentina S.A.
Av.del Libertador 5954 –
Piso 11 – Torre B
(C1428ARP) Buenos Aires
Phone: (+54) 11 5194 5000
info.gardena@
ar.husqvarna.com

Armenia

Garden Land Ltd.
61 Tigran Mets
0005 Yerevan

Australia

Husqvarna Australia Pty. Ltd.
Locked Bag 5
Central Coast BC
NSW 2252
Phone: (+61) (0) 2 4352 7400
customer.service@
husqvarna.com.au

Austria / Österreich

Husqvarna Austria GmbH
Consumer Products
Industriezeile 36
4010 Linz
Tel.: (+43) 732 77 01 01 - 90
consumer.service@
husqvarna.at

Azerbaijan

Firm Progress
a. Aliyev Str. 26A
10522 Baku

Belgium

GARDENA Belgium NV/SA
Sterrebeekstraat 163
1930 Zaventem
Phone: (+32) 2 720 92 12
Mail: info@gardena.be

Bosnia / Hercegovina

SILK TRADE d.o.o.
Industrijska zona Bukva bb
74260 Tešanj

Brazil

Husqvarna do Brasil Ltda
Av. Francisco Matarazzo,
1400 – 19º andar
São Paulo – SP
CEP: 05001-903
Tel: 0800-112252
marketing.br.husqvarna@
husqvarna.com.br

Bulgaria

Хускарна България ЕООД
Бул. „Андрей Ляпчев“ № 72
1799 София
Tel.: (+359) 02/9753076
www.husqvarna.bg

Canada / USA

GARDENA Canada Ltd.
100 Summerlea Road
Brampton, Ontario L6T 4X3
Phone: (+1) 905 972 93 30
info@gardena.ca

Chile

Maquinarias Agroforestales
Ltda. (Maga Ltda.)
Santiago, Chile
Avda. Chesterton
8355 comuna Las Condes
Phone: (+56) 2 202 4417
Dalton@magal.cl
Zipcode: 7560330

Temuco, Chile

Avda. Valparaiso # 01466
Phone: (+56) 45 222 126
Zipcode: 4780441

China

Husqvarna (China) Machinery
Manufacturing Co., Ltd.
No. 1355, Jia Xin Rd.,
Ma Lu Zhen, Jia Ding Dist.,
Shanghai
201801
Phone: (+86) 21 59159629
Domestic Sales
www.gardena.com.cn

Colombia

Husqvarna Colombia S.A.
Calle 18 No. 68 D-31, zona
Industrial de Montevideo
Bogotá, Cundinamarca
Tel. 571 2922700 ext. 105
jairo.salazar@
husqvarna.com.co

Costa Rica

Compania Exim
EuroIberoamericana S.A.
Los Colegios, Moravia,
200 metros al Sur del Colegio
Saint Francis – San José
Phone: (+506) 297 68 83
exim_euro@racsa.co.cr

Croatia

SILK ADRIA d.o.o.
Josipa Lončara 3
10090 Zagreb
Phone: (+385) 1 3794 580
silk.adria@zg-t-com.hr

Cyprus

Med Marketing
17 Digeni Akrita Ave
P.O. Box 27017
1641 Nicosia

Czech Republic

Husqvarna Česko s.r.o.
Türkova 2319/5b
149 00 Praha 4 – Chodov
Bezplatná infolinika:
800 100 425
servis@cz.husqvarna.com

Denmark

GARDENA/Husqvarna
Consumer Outdoor Products
Salgsafdelning Danmark
Box 9003
S-200 39 Malmö
info@gardena.dk

Dominican Republic

BOSQUESA, S.R.L.
Carretera Santiago Licey
Km. 5 ½
Esquina Copal II,
Santiago, Dominican Republic
Phone: (+809) 736-0333
joserbosquesa@claro.net.do

Ecuador

Husqvarna Ecuador S.A.
Arupos E1-181 y 10 de Agosto
Quito, Pichincha
Tel. (+593) 22800739
francisco.jacome@
husqvarna.com.ec

Estonia

Husqvarna Eesti OÜ
Consumer Outdoor Products
Kes tee 10, Aaviku küla
Rae vald
Harju maakond
75005 Estonia
kontakt.etj@husqvarna.ee

Finland

Oy Husqvarna Ab
Consumer Outdoor Products
Lauttarhankatu 8 B / PL 3
00581 HELSINKI
info@gardena.fi

France

GARDENA France
Immeuble Expositif
9 - allée des Pierres Mayettes
Zac des Barbanniers, B.P. 99
- F. 92232 GENNEVILLIERS
cedex
Tél. (+33) 01 40 85 30 40
service.consommateurs@
gardena.fr

Georgia

AJD Group
Beliashevili 8
1159 Tbilisi

Great Britain

Husqvarna UK Ltd
Preston Road
Aycliffe Industrial Park
Newton Aycliffe
County Durham
DL5 6UP
info.gardena@
husqvarna.co.uk

Greece

HUSQVARNA ΕΛΛΑΣ Α.Ε.Β.Ε.
Υπ. /μ Αφίστου 33Α
Βλ. Πλ. Κορωπίου
194 00 Κορωπί Αττικής
V.A.T. EL094094640
Phone: (+30) 210 6620 225
info@husqvarna-consumer.gr

Hungary

Husqvarna Magyarország Kft.
Ezred u. 1-3
1044 Budapest
Telephone: (+36) 1 251-4161
vevozsogalat.husqvarna@
husqvarna.hu

Iceland

O. Johnson & Kaaber
Túnguhalsi 1
110 Reykjavik
ooj@ojk.is

Ireland

Husqvarna UK Ltd
Preston Road
Aycliffe Industrial Park
Newton Aycliffe
County Durham
DL5 6UP
info.gardena@
husqvarna.co.uk

Italy

Husqvarna Italia S.p.A.
Via Como 72
23868 VALMADRERA (LC)
Phone: (+39) 0341.203.111
info@gardenaitalia.it

Japan

KAKUICHI Co. Ltd.
Sumitomo Realty &
Development Kojimaichi
BLDG., 8F
5-1 Nibanncyo
Chiyoda-ku
Tokyo 102-0084
Phone: (+81) 33264 7271
m_ishihara@kaku-ichi.co.jp

Kazakhstan

LAMED Ltd.
155/1., Tazhibayevy Str.
050060 Almaty
IP Schmidt
Abayavenue 3B
110 005 Kостanay

Kyrgyzstan

Alye Maki
av. Molodaya Gvardii 3 J
720014
Bishkek

Latvia

Husqvarna Latvija
Consumer Outdoor Products
Bākižu iela 6
LV-1024 Rīga
info@husqvarna.lv

Lithuania

UAB Husqvarna Lietuva
Consumer Outdoor Products
Ateities pl. 77C
LT-52104 Kaunas
centras@husqvarna.lt

Luxembourg

Magasins Jules Neuberg
39, rue Jacques Stas
Luxembourg-Gasperich 2549
Case Postale No.12
Luxembourg 2010
Phone: (+352) 40 14 011
api@neuberg.lu

Mexico

AFOSA
Av. Lopez Mateos Sur # 5019
Col. La Calma 45070
Zapopan, Jalisco
Mexico
Phone: (+52) 33 3818-3434
icornejo@afosa.com.mx

Moldova

Convel S.R.L.
290A Muncești Str.
2002 Chisinau

Netherlands

GARDENA Nederland B.V.
Postbus 50176
1305 AD ALMERE
Phone: (+31) 36 521 00 00
info@gardena.nl

Neth. Antilles

Jonka Enterprises N.V.
Sta. Rosa Weg 196
P.O. Box 8200
Curaçao
Phone: (+599) 9 767 66 55
pgm@jonka.com

New Zealand

Husqvarna New Zealand Ltd.
PO Box 76-437
Manukau City 2241
Phone: (+64) (0) 9 9202410
support.nz@husqvarna.co.nz

Norway

GARDENA
Husqvarna Consumer
Outdoor Products
Salgskontor Norge
Kleiveveien 6
1540 Vestby
info@gardena.no

Peru

Husqvarna Perú S.A.
Jr. Ramón Cárcamo 710
Lima 1
Tel: (+51) 1 3320400 ext. 416
juan_remuigo@
husqvarna.com

Poland

Husqvarna
Poland Spółka z o.o.
ul. Wysockiego 15 b
03-371 Warszawa
Phone: (+48) 22 330 96 00
gardena@husqvarna.com.pl

Portugal

Husqvarna Portugal, SA
Lagoa - Albarraque
2635 - 595 Rio de Mouro
Tel: (+351) 21 922 85 30
Fax: (+351) 21 922 85 36
info@gardena.pt

Romania

Maded International Srl
Soseaua Odaii 117 - 123,
RO 013603
București, S 1
Phone: (+40) 21 352.76.03
madex@mes.ro

Russia

ООО „Хускарна“
141400, Московская обл.,
г. Химки,
улица Ленинградская,
владение 39, стр.6
Бизнес Центр
„Химки Бизнес Парк“,
помещение ОВ02_04

Serbia

Domel d.o.o.
Autoput za Novi Sad bb
11273 Belgrade
Phone: (+381) 11848 88 12
miroslav.jejina@domel.rs

Singapore

Hy-Ray PRIVATE LIMITED
40 Jalan Pemimpin
02-08 Tat Ann Building
Singapore 577185
Phone: (+65) 6253 2277
shiyang@hyray.com.sg

Slovak Republic

Husqvarna Česko s.r.o.
Türkova 2319/5b
149 00 Praha 4 – Chodov
Bezplatná infolinika:
800 154 044
servis@sk.husqvarna.com

Slovenia

Husqvarna Austria GmbH
Consumer Products
Industriezeile 36
4010 Linz
Tel.: (+43) 732 77 01 01 - 90
consumer.service@
husqvarna.at

South Africa

Husqvarna
South Africa (Pty) Ltd
Postnet Suite 250
Private Bag X6,
Cascades, 3202
South Africa
Phone: (+27) 33 846 9700
info@gardena.co.za

Spain

Husqvarna España S.A.
C/ Basauri, nº 6
La Florida
28023 Madrid
Phone: (+34) 91 708 05 00
atencioncliente@gardena.es

Suriname

Agrofrix n.v.
Verlengde Hogestraat # 22
Phone: (+597) 472426
agrofrix@sr.net
Pobox : 2006
Paramaribo
Suriname – South America

Sweden

Husqvarna AB
S-561 82 Huskvarna
info@gardena.se
Switzerland / Schweiz
Husqvarna Schweiz AG
Consumer Products
Industriestrasse 10
5506 Mägenwil
Phone: (+41) (0) 848 800 464
info@gardena.ch

Turkey

GARDENA Dost Diş Ticaret
Müesseslik A.Ş.
Sanayi Cad. Adil Sokak
No: 1/B /Kartal
34873 İstanbul
Phone: (+90) 216 38 93 939
info@gardena-dost.com.tr

Ukraine / Україна

ТОВ «Хусарна Україна»
вул. Васильківська, 34,
офіс 204-г
03022, Київ
Tel: (+380) 044 498 39 02
info@gardena.ua

Uruguay

FELI SA
Entre Ríos 1083 CP 11800
Montevideo – Uruguay
Tel: (+598) 22 03 18 44
info@felisa.com.uy

Venezuela

Corporación Casa y Jardín C.A.
Av. Caroní, Edif. Trenzmen, PB.
Colinas de Bello Monte.
1050 Caracas.
Tlf: (+58) 212 992 33 22
info@casayjardin.net.ve

8840-20.960.06/0112

© GARDENA
Manufacturing GmbH
D-89070 Ulm
http://www.gardena.com