

3000/4 eco Art. 1753

D Betriebsanleitung
Hauswasserwerk

GB Operating Instructions
Pressure Tank Unit

F Mode d'emploi
Groupe de surpression

NL Gebruiksaanwijzing
Hydrofoorpomp

S Bruksanvisning
Hydroforpump

DK Brugsanvisning
Husvandværk

FI Käyttöohje
Painevesiyksikkö

N Bruksanvisning
Trykktank

I Istruzioni per l'uso
Autoclave

E Instrucciones de empleo
Estación de Bombeo con Calderín

P Manual de instruções
Bomba doméstica

PL Instrukcja obsługi
Zestaw hydroforowy

H Használati utasítás
Házi vízellátó

CZ Návod k obsluze
Domácí vodárna

SK Návod na obsluhu
Domáca vodáreň

GR Οδηγίες χρήσης
Πιεστικό με βαρέλι

RUS Инструкция по эксплуатации
Станция бытового водоснабжения автоматическая

SLO Navodilo za uporabo
Hišna vodna črpalka

HR Upute za uporabu
Kućni hidroforska pumpa

SRB Uputstvo za rad
BIH Kućna hidroforska pumpa

UA Інструкція з експлуатації
Домова водопровідна станція

RO Instrucțiuni de utilizare
Hidrofor cu rezervor

TR Kullanma Kılavuzu
Konut Suyu Tertibatı

BG Инструкция за експлоатация
Хидрофорна уредба с разширителен съд

AL Manual përdorimi
Impiant uji për shtëpi

EST Kasutusjuhend
Hüdrofooriga veeautomaat

LT Eksploatavimo instrukcija
Siurblys su slėgio rezervuaru

LV Lietošanas instrukcija
Spiedtvertnes ierīce



Translation of the original German operating instructions.

Please read the operating instructions carefully and observe the notes given. Use these operating instructions to familiarise yourself with the product, the proper use and the safety instructions.



For safety reasons, children and young people under the age of 16, as well as people not familiar with these operating instructions, may not use this product. Persons with reduced physical or mental abilities may use the product only if they are supervised or instructed by a responsible person. Children must be supervised to ensure that they do not play with the product.

→ Keep these operating instructions in a safe place.

Contents:

1. Area of application of your GARDENA Pressure Tank Unit . . .	11
2. Safety Instructions	12
3. Initial Operation	13
4. Operation	14
5. Putting into Storage	15
6. Maintenance	15
7. Trouble-Shooting	16
8. Available accessories	18
9. Technical Data	18
10. Service/Warranty	19

1. Area of application of your GARDENA Pressure Tank Unit

Correct use:

The GARDENA Pressure Tank Unit is intended for private use in the house and garden; it is not intended for operation of watering equipment and accessories in public gardens.

Liquids pumped:

The GARDENA Pressure Tank Unit can be used to deliver rainwater, tap water and chlorinated swimming pool water.

Please note:



The GARDENA Pressure Tank Unit is not suitable for continuous operation (e.g. industrial use, continuous circulation operations). Corrosive, easily combustible, aggressive or explosive liquids (such as gasoline, petroleum or nitro thinner), saltwater and food must not be pumped. The temperature of the liquid must not exceed 35 °C.

2. Safety Instructions

Electrical safety



DANGER! Electric shock!

Risk of injury due to electric shock!

→ **Always unplug your Pressure Tank Unit before filling, after operation, when troubleshooting and before carrying out any maintenance work.**

Caution: Pursuant to DIN VDE 0100-702, the use of the pump is only permissible if the pump is operated via a residual-current device (FI switch).

The pump must be located on solid, even ground, protected from flooding. Take care that the pump cannot fall into water.

As an additional safety device an authorised safety switch can be used.

→ Please ask your electrician for his advice.

Data indicated on the type plate must match the technical data of the mains supply.

Pursuant to DIN VDE 0620 the power cable as well as any extension cable must not have a smaller diameter than rubber sheathed cables described with letter symbols H07 RNF.

Protect the power cable from heat, oil and sharp edges.

Do not use the power cable for carrying the pump or for unplugging.

In Austria

In Austria the electrical connection must satisfy the ÖVE-EM 42, T2 (2000)/1979 § 22 to § 2022.1. This requires that pumps used for swimming pools and garden ponds may only be powered through an isolating transformer.

→ Please ask your electrician for his advice.

In Switzerland

In Switzerland portable devices that are used outdoors must be connected through an earth leakage circuit breaker. Mobile appliances that are used outdoors must be connected via a residual-current device.

General Information



Risk of injury due to hot water!

If the pressure switch is defective or if the water supply on the intake side of the pump fails, any water remaining in the pump may heat up, generating a risk of injuries caused by hot water on leakage.

The pump is equipped with a temperature fuse, which switches off the pump at high water temperatures (approx. 65 °C).

→ **After temperature-related cut-out, disconnect the pump from the mains via the main circuit breaker, let the water cool (approx. 10 – 15 min.) and secure the water supply on the intake side before putting into operation again.**

→ Before operating the pressure tank unit, first make a visual check to ensure there is no damage to the pressure tank unit (especially regarding power cable and plug).

A damaged pressure tank unit must not be used.

→ In case of damage, please have the pressure tank unit checked by our GARDENA Service Centre or by an authorised electrician.

Protect the pump from rain. Do not use the pressure tank unit in a wet or moist area.

In order to avoid dry-running of the pressure tank unit, take care that the end of the suction hose is always submerged into the liquid.

The pressure tank unit must not be run dry nor with the stopcock in the suction pipework closed.

→ Before each operation, fill the pressure tank unit to overflowing with approx. 2 to 3 l of the liquid to be pumped!

Sand and other abrasive substances in the liquid cause increased wear and reduce the pump's output.

When using the pump for domestic water supply, please adhere to the local water and sewerage regulations. In addition observe the regulations of DIN 1988.

→ If necessary contact your local water authority.

3. Initial Operation

Installing the Pressure Tank Unit:

The installation position must be firm and dry, and permit a secure mounting for the pressure tank unit.

→ Install the Pressure Tank Unit at a safe distance from the pumping medium.

The pump must be installed in a location with low air humidity and sufficient ventilation in the area of the ventilation slots. It must be at a distance of at least 5 cm from the walls. No dirt contamination (e.g. sand or earth) may be sucked in through the ventilation slots.

Fixed installation of the Pressure Tank Unit:

→ The Pressure Tank Unit can be screwed with all 4 feet ② onto a solid surface ①.

Alternatively, spring mounted feet (Art. 1753-00.901.00) for low vibration and quiet running are available as accessories via the GARDENA Service.

Install the pressure tank unit so that there is room to place a suitably sized drainage tray under the drain screw ③ to allow the unit or system to be drained.

If possible, install the unit higher than the surface of the water to be pumped. If this is not possible, install a vacuum-resistant valve between the unit and the suction hose, for example for cleaning the integrated filter.

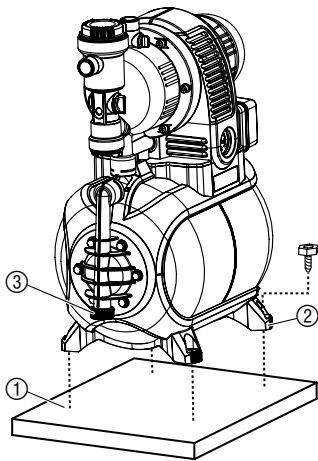

If the pump is permanently installed indoors for domestic water supply, the Pressure Tank Unit should not be connected to the domestic water pipework with rigid pipes but with flexible tubing, to reduce noise and to avoid damage to the pump caused by pressure blows.

If the system is being installed permanently, please fit suitable valves on both the intake and delivery sides. This is important e.g. for maintenance and cleaning work or if the system is being shut down.

The connection pieces on the intake and delivery sides may only be tightened by hand.

Connect the hose to the suction side:

A vacuum-tight suction hose must be used e.g.:

- GARDENA Suction Unit **Art. no. 1411/1418/1412** or
- GARDENA Bore Hole Suction Hose **Art. no. 1729**.

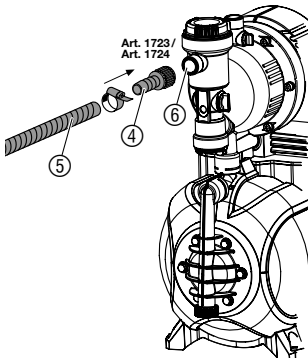

Do not use any water hose snap connection system components on the intake side!

→ **Connect the suction hose ⑤ with the intake side connection ⑥ of the pump.**

Connect the suction hoses ⑤ without a threaded connector via a connection piece (e.g. **Art. no. 1723/1724**) ④ with the intake side connection and screw in place so that they are airtight.

To reduce the pump repriming time, we recommend using a suction hose with backflow preventer, which prevents the suction hose emptying automatically when the Pressure Tank Unit is switched off.

For suction heights exceeding 4 m also secure the suction hose ⑤ (e.g. by fastening it to a wooden post) to relieve the pump of the weight of the suction hose.

If very fine dirt is present in the pumping medium, we recommend the use of a **GARDENA Pump Preliminary Filter Art. no. 1730/1731**.

Connect hose to the output side:

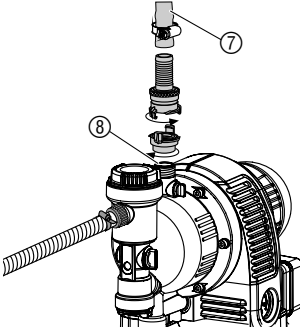

Note:

Use pressure-tight GARDENA hoses, 19 mm (3/4") in diameter, in connection with the GARDENA Quick-Release Threaded Connector with 33.3 mm (G1) internal thread, **Art. no. 7109**, and the GARDENA Suction and High Pressure Connector, **Art. no. 7120**, for 19 mm (3/4") hoses and a GARDENA Hose Clip, **Art. no. 7192**.

Under no circumstances use these hoses on the suction side.

→ Connect delivery hose ⑦ to the delivery side connection ⑧.

→ Tip: If permanent pipes are installed, they must be laid at an ascending angle in order to allow the water to flow back into the pump on the pressure side.

4. Operation

Starting the Pressure Tank Unit:

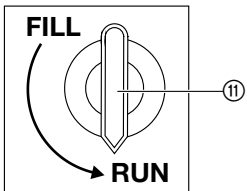
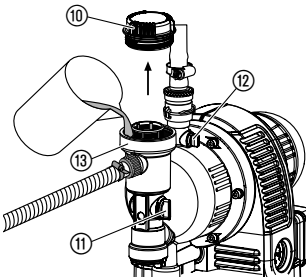
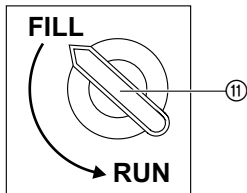

DANGER! Electric shock!

→ Before filling the pump, unplug the equipment from the mains.

WARNING! Pump running dry!

→ Fill the pump to the overflow (approx. 2 to 3 l) with water each time before the pump is switched on, so it does not run dry.

1. Unscrew the cover ⑩ of the filter chamber by hand.
2. Turn the rotary switch ⑪ to **FILL**.
The integrated non-return valve will open.
3. Open the air bleed ⑫.
4. Open any valves in the delivery line (watering accessories, water stop, etc.) and drain off any residual water in the delivery hose so that the air can escape during filling and priming.
5. Slowly pour pumping medium (approx. 2 to 3 l) through the filler neck ⑬ until water emerges from the air bleed ⑫.
6. Screw the filter chamber cover ⑩ closed again, turning by hand until it stops.
7. Close venting ⑫ and turn rotary switch ⑪ to **RUN**.
8. Insert the mains plug into a **230 V** mains socket.
CAUTION! The pump will start immediately!

Once the maximum pressure is reached the pump will switch off automatically. When the pressure falls below the minimum value due to water being drawn off, the pump will switch on again automatically.

The maximum self-priming head of 8 m is only achieved if the pump is filled until it overflows from the filler connection ⑬ and the delivery hose is held high enough during self-priming so that no water can escape from the pump via the delivery hose. It is not necessary to hold up the delivery hose if filled suction hoses with backflow preventer are used.

ECO switch:



In order to save energy (up to 15 %), the cut-out pressure on the pump can, depending on the individual application, be regulated between **ECO** and **MAX** (the pressure difference between **ECO** and **MAX** totals approx. 1 bar).

→ Turn the **ECO** rotary switch ⑭ to the required position.

Note on the use of sprinklers:

Depending on the flow rate of the sprinkler, an uneven watering pattern may occur through the pump being switched on and off automatically.

5. Putting into Storage

Storage:



If there is a risk of frost, the Pressure Tank Unit must be emptied and stored where it will not become frozen. Store out of the reach of children.

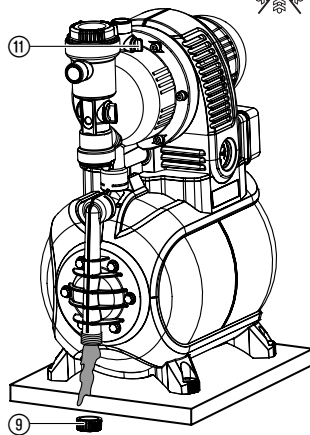

1. Unplug the mains connection for the pump.
2. Turn the rotary switch ⑪ to **FILL**.
3. Open the delivery side consumer.
4. Unscrew the end cap ⑨ and drain off the water.
5. Store the pressure tank unit in a dry, frost-free place.

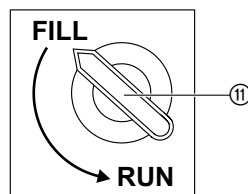

Disposal:

(in accordance with directive 20002/96/EC)



The unit must not be disposed of with normal household waste but must be disposed of in accordance with local environmental regulations.

6. Maintenance



DANGER! Electric shock!

→ Pull out mains plug before undertaking any maintenance.

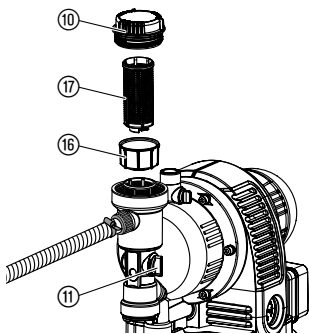
Clean suction filter:

1. Turn the rotary switch ⑪ to **RUN**.
2. If necessary, close all the shut-off devices on the intake side.
3. Unscrew and remove cover ⑩ of the filter chamber.
4. Draw out filter unit ⑬ ⑭ vertically upwards.
5. Hold beaker ⑮ firmly, turn filter ⑯ anti-clockwise **A** and draw out **B** (bayonet fitting).
6. Clean beaker ⑮ under running water and clean the filter ⑯ e.g. with a soft brush.
7. Refit filter again in reverse order.

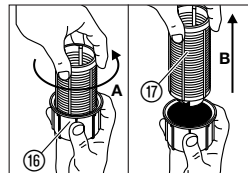
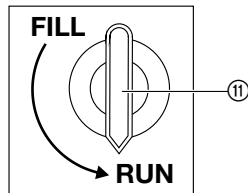
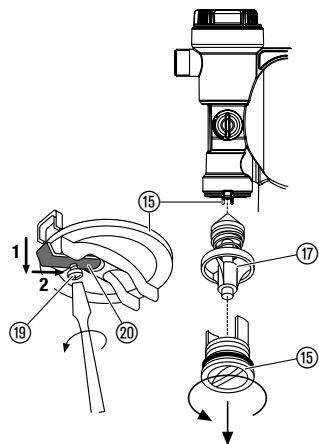
**Cleaning the check valve:**

1. Turn the rotary switch ⑪ to **FILL**.
2. If necessary, close all valves on the intake side.
3. Open all pressure side outlets, so that the pressure side is depressurised.
4. Unscrew the end cap ⑨ and drain off the water (see 5. Putting into Storage "Storage").
5. Undo screw ⑲ and slide the clip ⑳ upwards **1** and to the rear **2** into the bearing groove.
6. Screw out the cover ⑮ of the check valve (if applicable using a suitable tool).
7. Remove the valve body ⑱ and wash it under running water.
8. Refit in reverse order.
9. Switch the Pressure Tank Unit back on again (see 4. Operation)

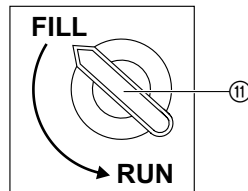
**7. Trouble-Shooting****DANGER! Electric shock!**

→ **Unplug the cable at the mains before trouble-shooting.**

Work on the electrical parts must only be carried out by GARDENA Service Centres.

Problem	Possible Cause	Remedy
The pump sucks nothing up.	Rotary switch is not turned to RUN .	→ Restart the pump (see 4. Operation).
	The pump is sucking air through a leak at a connection on the suction side.	→ Check all connections and make them air-tight as necessary.

Problem	Possible Cause	Remedy
The pump sucks nothing up.	Pump is not adequately primed with the liquid to be pumped.	→ Fill the pump and ensure that the water is able to flow back into the pressure line (see 4. Operation).
	Air cannot escape on the pressure side, because the pressure side outlets are closed.	→ Open the pressure side outlets.
	End of the suction hose is not in the water, the non-return valve at the end of the suction hose is missing or leaking, the suction hose is kinked, connections are leaking or the suction filter is blocked.	→ Check the complete suction hose from suction point through to the pump for leak-tightness and repair any leaks as necessary. Check the intake side water supply. If applicable, clean the suction filter.
Pump motor does not start or stops suddenly during operation.	Mains plug not plugged in.	→ Insert mains plug into a mains socket (230 V AC).
	Power failure.	→ Check fuse and cables.
	Thermo circuit breaker activated (pump housing heated).	→ Ensure sufficient ventilation and allow the pump to cool for approx. 15 min. Unplug the pump and restart it (see 4. Operation).
Pump motor runs, but quantity delivered or pressure fall away suddenly.	Leak on the suction side.	→ Repair the leak.
	Too little water on intake side.	→ Throttle the pump on the pressure side so that the flow quantity on the suction side is governed by that on the pressure side.
	Suction filter, check valve or backflow preventer at the end of the suction hose is blocked.	→ Clean the suction filter, check valve or backflow preventer.
Pump switches on and off too frequently.	Leakage on delivery side.	→ Check the delivery side for leaks and remove as necessary.
	Pressure in the boiler is too low.	→ Top up the air in the storage tank (see below).
	Boiler diaphragm is damaged.	→ Contact GARDENA Service.
	Rotary switch is not turned to RUN .	→ Turn the rotary switch completely to RUN .

Top up the air in the storage tank:

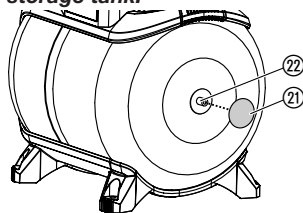

The pressure in the storage tank must be approx. 1.6 bar.

To top up the air, an air pump/tyre pump with a pressure gauge (manometer) is required.

1. Unscrew the protective cover (21).
2. Attach the air pump/tyre pump to the boiler valve (22) and pump air in until the air pump/tyre pump pressure gauge shows approx. 1.6 bar.
3. Screw the protective cover (21) back on.



For any other malfunctions please contact the GARDENA service department. Repairs must only be carried out by GARDENA service departments or specialist dealers authorised by GARDENA.

8. Available accessories

GARDENA Suction Hoses	Kink and vacuum-resistant, sold by the metre with 19 mm (3/4"), 25 mm (1") or 32 mm (5/4") diameter without fittings or in fixed lengths Art. no. 1411/1418, complete with fittings.	
GARDENA Suction Hose Fittings	For vacuum-resistant connection of the pump to the suction hose sold by the metre.	Art. no. 1723/1724
Suction Filter with Backflow Preventer	To equip suction hoses with Backflow Preventer sold by the metre.	Art. no. 1726/1727
GARDENA Pump Preliminary Filter	Recommended for pumping sandy water.	Art. no. 1730/1731
GARDENA Bore Hole Suction Hose	For vacuum-resistant connection of the pump to boreholes or pipe networks. Length 0.5 m. With 33.3 mm (G1) female thread at both ends.	Art. no. 1729
GARDENA Spring mounted feet (4 x)	Spring mounted feet for vibration-free, quiet running. Can be obtained via GARDENA Service.	Art. no. 1753-00.901.00

9. Technical Data

Type	3000/4 eco (Art. no. 1753)
Voltage/Frequency	230 V AC/50 Hz
Rated power	650 W
Connection cable	1.5 m H05-RNF
Max. delivery capacity	2800 l/h
Max. pressure/ max. delivery head	4.0 bar/40 m
Max. suction height	8 m
Cut-in pressure	1.5 ± 0.1 bar
Switch-off pressure eco/max.	2.2/3.2 bar
Perm. internal pressure (delivery side)	6 bar
Weight	13.6 kg
Dimensions (L x W x H)	45 cm x 29 cm x 62 cm
Sound power level L_{WA} (measured/guaranteed)	78.5 dB(A)/81 dB(A)
Uncertainty K_{WA}	2.2 dB(A)

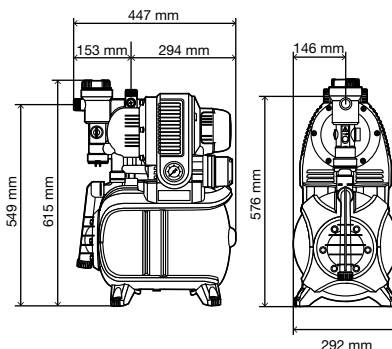

Warranty:

GARDENA guarantees this product for 2 years (from date of purchase). This guarantee covers all serious defects of the unit that can be proved to be material or manufacturing faults. Under warranty we will either replace the unit or repair it free of charge if the following conditions apply:

- The unit must have been handled properly and in keeping with the requirements of the operating instructions.
- Neither the purchaser or a non-authorized third party have attempted to repair the unit.

The impeller and filter are wearing parts and are therefore not covered by the warranty.

This manufacturer's guarantee does not affect the user's existing warranty claims against the dealer/seller.

If you have any problems with this product, please contact our Service or return the defective unit together with a short description of the problem – in case of guarantee, with a copy of the receipt – postage paid to one of the GARDENA Service Centres listed on the back of this leaflet.

Pumpenkennlinie
Performance characteristics
Courbe de performance
Prestatiegrafiek
Kapacitetskurva
Ydelses karakteristika
Pumpun ominaiskäyrä
Pumpekarakteristikk
Curva di rendimento
Curva característica de la bomba
Características de performance
Charakterystyka pompy
Szivattyú-jelleggörbe
Charakteristika čerpadla
Charakteristiky čerpadla
Χαρακτηριστικό διάγραμμα
Характеристика насоса
Karakteristika črpalke
Obilježja pumpe
Karakteristika pumpe
Крива характеристики насоса
Caracteristică pompă
Pompa karakter eğrisi
Помпена характеристика
Fuqia e pompës
Pumba karakteristik
Siurblio charakteristinė kreivė
Sūkņa raksturlīkne

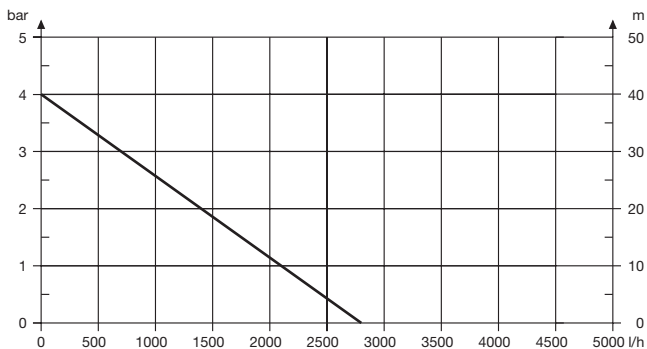

D Produkthaftung

Wir weisen ausdrücklich darauf hin, dass wir nach dem Produkthaftungsgesetz nicht für durch unsere Geräte hervorgerufene Schäden einzustehen haben, sofern diese durch unsachgemäße Reparatur verursacht oder bei einem Teileaustausch nicht unsere originale GARDENA Teile oder von uns freigegebene Teile verwendet wurden und die Reparatur nicht vom GARDENA Service oder dem autorisierten Fachmann durchgeführt wird. Entsprechendes gilt für Ergänzungssteile und Zubehör.

GB Product Liability

We expressly point out that, in accordance with the product liability law, we are not liable for any damage caused by our units if it is due to improper repair or if parts exchanged are not original GARDENA parts or parts approved by us, and, if the repairs were not carried out by a GARDENA Service Centre or an authorised specialist. The same applies to spare parts and accessories.

F Responsabilité

Nous vous signalons expressément que GARDENA n'est pas responsable des dommages causés par ses appareils, dans la mesure où ces dommages seraient causés suite à une réparation non conforme, dans la mesure où, lors d'un échange de pièces, les pièces d'origine GARDENA n'auraient pas été utilisées, ou si la réparation n'a pas été effectuée par le Service Après-Vente GARDENA ou l'un des Centres SAV agréés GARDENA. Ceci est également valable pour tout ajout de pièces et d'accessoires autres que ceux préconisés par GARDENA.

NL Productaansprakelijkheid

Wij wijzen er nadrukkelijk op, dat wij op grond van de wet aansprakelijkheid voor producten niet aansprakelijk zijn voor schade ontstaan door onze apparaten, indien deze door onvakkundige reparatie veroorzaakt zijn, of er bij het uitswisselen van onderdelen geen gebruik gemaakt werd van onze originele GARDENA onderdelen of door ons vrijgegeven onderdelen en de reparatie niet door de GARDENA technische dienst of de bevoegde vakman uitgevoerd werd. Ditzelfde geldt voor extra-onderdelen en accessoires.

S Produktansvar

Tillverkaren är inte ansvarig för skada som orsakats av produkten om skadan beror på att produkten har reparerats felaktigt eller om, vid reparation eller utbyte, andra än Original GARDENA reservdelar har använts. Samma sak gäller för kompletteringsdelar och tillbehör.

DK Produktansvar

Vi gør udtrykkeligt opmærksom på, at vi i henhold til produktansvarsloven ikke er ansvarlige for skader forårsaget af vores udstyr, såfremt det sker på grund af uautoriserede reparationer eller hvis dele er skiftet ud og der ikke er anvendt originale GARDENA dele eller dele godkendt af os, eller hvis reparationerne ikke er udført af GARDENA-service eller en autoriseret fagmand. Det samme gælder for ekstra udstyr og tilbehør.

FI Tuotevastuu

Korostamme nimenomaan, että tuotevastuulain nojalla emme ole vastuussa laitteistamme johtuneista vahingoista, mikäli nämä ovat aiheutuneet epäasianmukaisesta korjauksesta tai osia vaihdettaessa ei ole käytetty alkuperäisiä GARDENA-varaosia tai hyväksymiämme osia ja korjauksen on suorittanut muu kuin GARDENA-huoltokeskus tai valtuuttamamme ammattihenkilö. Tämä pätee myös lisäosiin ja lisävarusteisiin.

I Responsabilità del prodotto

Si rende espressamente noto che, conformemente alla legislazione sulla responsabilità del prodotto, non si risponde di danni causati da nostri articoli se originati da riparazioni eseguite non correttamente o da sostituzioni di parti effettuate con materiale non originale GARDENA o comunque da noi non approvato e, in ogni caso, qualora l'intervento non venga eseguito da un centro assistenza GARDENA o da personale specializzato autorizzato. Lo stesso vale per le parti complementari e gli accessori.

E Responsabilidad de productos

Advertimos que conforme a la ley de responsabilidad de productos no nos responsabilizamos de daños causados por nuestros aparatos, siempre y cuando dichos daños hayan sido originados por arreglos o reparaciones indebidas, por recambios con piezas que no sean piezas originales GARDENA o bien piezas no autorizadas por nosotros, así como en aquellos casos en que la reparación no haya sido efectuada por un Servicio Técnico GARDENA o por un técnico autorizado. Lo mismo es aplicable para las piezas complementarias y accesorios.

P Responsabilidade sobre o produto

Queremos salientar que segundo a lei da responsabilidade do fabricante, nós não nos responsabilizaremos por danos causados pelo nosso equipamento, quando estes ocorrerem em decorrência de reparações inadequadas ou da substituição de peças por peças não originais da GARDENA, ou peças não autorizadas. A responsabilidade tornar-se-á nula também depois de reparações realizadas por oficinas não autorizadas pela GARDENA. Esta restrição valerá também para peças adicionais e acessórios.

PL Odpowiedzialność za produkt

Zwracamy Państwa uwagę, że nie ponosimy odpowiedzialności za uszkodzenia naszych maszyn, bądź szkody spowodowane ich wadliwym funkcjonowaniem, powstałe na skutek nieprawidłowo przeprowadzonych napraw lub użycia nieoryginalnych części zamiennych. Naprawy winny być przeprowadzane tylko przez punkty serwisowe Husqvarna lub autoryzowane serwisy. Dotyczy to również części uzupełniających i oprzyrządowania.

H Termékszavatosság

Nyomatékosan utalunk arra a tényre, hogy a termékszavatossági törvény szerint nem kell jótállást vállalnunk azokra a károokra, amelyeket nem a mi készülőkeink okoztak, ha ezeket szakszerűtlen javítás okozta vagy egy alkatrész kicserélésénél nem a mi eredeti GARDENA alkatrészceinket vagy általunk engedélyezett alkatrészeket használtak fel és a javítást nem a GARDENA szerviz vagy egy erre felhatalmazott szakember végezte. Hasonlóképpen érvényes ez a kiegészítő alkatrészekre és tartozékokra is.

CZ Odpovědnost za výrobek

Výslovně upozorňujeme na to, že podle zákona o odpovědnosti za výrobek neneseme odpovědnost za škody způsobené našimi přístroji, pokud byly způsobené neodbornou opravou nebo použitím jiných než našich originálních náhradních dílů GARDENA nebo námi schválených dílů a neprovedením opravy servisem GARDENA nebo autorizovaným odborníkem. Odpovídající platí i pro doplňkové díly a příslušenství.

SK Predmet záruky

Upozorňujeme dôrazne na to, že podľa zákona o poskytovaní záruk nezodpovedáme za škody spôsobené našimi výrobkami, v prípade, že boli boli vyvolané neodbornými opravami, výmenou dielcov, ktoré nepatria k originálnym dielom GARDENA alebo neboli nami schválené a rovnako boli spôsobené servisnými zásahmi, ktoré neboli vykonané servisom GARDENA alebo autorizovaným odborníkom. Rovnako to platí pre doplnky a príslušenstvo.

GR Ευθύνη για το προϊόν

Σας υπενθυμίζουμε ρητά, ότι σύμφωνα με το νόμο περί ευθύνης για τα προϊόντα δεν ευθυνόμαστε για ενδεχόμενες βλάβες που προκαλούνται από τις συσκευές μας, εφόσον οφείλονται σε μία ακατάλληλη επισκευή ή σε μια αντικατάσταση τμημάτων για την οποία δεν έχουν χρησιμοποιηθεί τα πρωτότυπα ανταλλακτικά της GARDENA ή τα από μας εγκριμένα ανταλλακτικά και σε περίπτωση που δεν εκτελείται η επισκευή από το Τμήμα Εξυπηρέτησης Πελατών της GARDENA ή από έναν εξουσιοδοτημένο εξειδικευμένο τεχνίτη. Το ίδιο ισχύει για εξαρτήματα και συμπληρωματικά τμήματα.

SLO Jamstvo za izdelek

Pismo no poudarjamo, da po zakonu jamstva za izdelek nismo odgovorni za škodo, ki bi nastala zaradi uporabe našeга izdelka, prav tako tudi ne za škodo ki bi nastala zaradi nepravilnega popravila izdelka ali pri napačni zamenjavi delov, ki niso originalni deli GARDENA ali pri uporabi z naše strani potrjenih delov, ki pa niso bili vgrajeni v servisu GARDENA ali v naši pooblašteni servisni službi. Enako velja tudi za nadomestne dele in opremo.

RO Responsabilitatea legala a produsului

Menționăm în mod expres ca, în concordanță cu responsabilitatea legală a produsului, nu suntem răspunzători de nici un accident provocat de produsele noastre dacă se datorează reparării necorespunzătoare sau dacă piesele de schimb nu sunt originale GARDENA sau aprobate de GARDENA, sau dacă reparațiile nu au fost efectuate de un Centru de Service GARDENA sau un specialist autorizat. Aceleași prevederi se aplică și pieselor de schimb și accesoriilor.

BG Отговорност за качество

Изрично подчертаваме, че съгласно закона за отговорност за качество, ние не носим отговорност за вредите причинени от нашите уреди, ако същите са причинени от неправилен ремонт или при подмяната на части не са използвани оригинални части на GARDENA или части одобрени от нас и ремонта не е извършен от сервиз на GARDENA или оторизиран специалист. Същото важи за допълнителните части и принадлежности.

EST Tootevastutus

Juhime teie tähelepanu sellele, et tootevastutusseaduse kohaselt ei vastuta me meie seadmete poolt põhjustatud kahjude eest, kui need on tekkinud asjatundmatu paranduse tagajärjel või kui detaili vahetamisel ei kasutatud GARDENA originaalvaruosi ega meie poolt kasutada lubatud varuosi ja kui parandustööd ei ole teinud GARDENA klienditeenindusspetsialistid ega meie volitatud spetsialistid. Sama kehtib lisadetailide ja tarvikute kohta.

LT Atsakomybė už produkciją

Nurodome, kad remdamiesi Atsakomybės už produkciją įstatymu, neatsakome už nuostolius, sukeltus mūsų prietaisų, jei jie atsirado dėl netinkamo remonto, arba, jei keičiant dalis, buvo naudojamos neoriginalios GARDENA dalys arba dalys, kurių mes neleidome naudoti, o remontą atliko ne GARDENA servisas arba neįgaliotasis specialistas. Tas pats galioja papildomoms dalims ir priedams.

LV Produkta atbildība

Mēs skaidri norādām uz to, ka saskaņā ar Produktu atbildības likumu, mēs neatbildam par mūsu iekārtu radītiem zaudējumiem, ciktāl tos ir izraisījis neatbilstošs remonts vai daļu nomaiņa ar neoriģinālām GARDENA daļām vai ne ar mūsu norādītajām detaļām un remontu nav veicis GARDENA serviss vai pilnvarots speciālists. Tas pats attiecas uz papildinošajām daļām un piederumiem.

<p>D EG-Konformitterklrung Der Unterzeichnete Husqvarna AB, 561 82 Huskvarna, Sweden besttigt, dass die nachfolgend bezeichneten Gerte in der von uns in Verkehr gebrachten Ausfhrung die Anforderungen der harmonisierten EU-Richtlinien, EU-Sicherheitsstandards und produkt-spezifischen Standards erfullen. Bei einer nicht mit uns abgestimmten nderung der Gerte verliert diese Erklrung ihre Gltigkeit.</p>	<p>PL Deklaracja zgodnoci Unii Europejskiej Husqvarna AB, 561 82 Huskvarna, Sweden potwierdza, że poniżej okreone urzdzenia w wersji oferowanej przez nas do sprzedaŹy spełniają wymagania zharmonizowanych dyrektyw Unii Europejskiej, standardu bezpieczestwa Unii Europejskiej i standardu specyficznego dla tego typu produktów. W przypadku zmiany urzdzenia, która nie została z nami uzgodniona, niniejsza deklaracja traci moc obowizywania.</p>
<p>GB EU Declaration of Conformity The undersigned Husqvarna AB, 561 82 Huskvarna, Sweden hereby certifies that, when leaving our factory, the units indicated below are in accordance with the harmonised EU guidelines, EU standards of safety and product specific standards. This certificate becomes void if the units are modified without our approval.</p>	<p>H EU-Megfelelségi nyilatkozat Alulirott, a Husqvarna AB, 561 82 Huskvarna, Sweden igazolja azt, hogy az lbbiakban megnevezett kszlekek, az ltalunk forgalomba hozott kivitelben teljesitik a harmonizcis EU-irnyelvek, az EU biztonsgi szabvnyok s a termekre jellemz szabvnyok kvetelmnyeit. Ha a kszlekeken a mi beleyezsnk nlkl vltoztats vgeznek, akkor ez a nyilatkozat ervnyet veszti.</p>
<p>F Certificat de conformit aux directives europennes Le constructeur, soussign : Husqvarna AB, 561 82 Huskvarna, Sweden dclare qu' la sortie de ses usines le matriel neuf dsign ci-dessous tait conforme aux prescriptions des directives europennes nonces ci-aprs et conforme aux rgles de scurit et autres rgles qui lui sont applicables dans le cadre de l'Union europenne. Toute modification porte sur ce produit sans l'accord express de GARDENA supprime la validit de ce certificat.</p>	<p>CZ Prohlšení o shod EU Podepsan Husqvarna AB, 561 82 Huskvarna, Sweden potvrzuje, že dle uveden pstroje v nm do provozu uvedenm proveden spluj poŹadavky harmonizovanch smrnice EU, bezpenostnch norem EU a norem specifickch pro vrobek. P nm neschvlen zmnn pstroji ztrci toto prohlšení platnost.</p>
<p>NL EU-overeenstemmingsverklaring Ondergetekende Husqvarna AB, 561 82 Huskvarna, Sweden bevestigt, dat de volgende genoemde apparaten in de door ons in de handel gebrachte uitvoering voldoen aan de eis van, en in overeenstemming zijn met de EU-richtlijnen, de EU-veiligheidsstandaard en de voor het product specifieke standaard. Bij een niet met ons afgestemde verandering aan de apparaten verliest deze verklaring haar geldigheid.</p>	<p>SK EU-Vyhlenie o zhode Nišie uveden firma Husqvarna AB, 561 82 Huskvarna, Sweden vyhlasuje, že uveden zariadenia, ktor sme uviedli na trh v ich vyhotoven spluj poŹiadavky harmonizovanch predpisov EU, bezpenostnch standardov EU a vrobn-specifickch standardov. P zmene zariadenia, ktor nebla odsuhlasen vrobcom stráca toto vyhlsenie platnost.</p>
<p>S EU Tillverkarintyg Undertecknad firma Husqvarna AB, 561 82 Huskvarna, Sweden intygar hrmed att nedan nmnda produkter verensstmmer med EU:s direktiv, EU:s skerhetsstandard och produktspecifikation. Detta intyg upphr att glla om produkten ndras utan vrt tillstnd.</p>	<p>GR Διηλωση Συμμρφωσης προς τις Οδηγίες της ΕΕ Η υπογραφσα Husqvarna AB, 561 82 Huskvarna, Sweden δηλώνει, οτι τα ελη αναφερόμενα εκδιδόμενα απο την εταιρία μας προϊόντα ανταποκρίνονται σε όλες τις εναρμονισμένες προδιαγραφές της ΕΕ, στα πρτυπα ασφαλείας της ΕΕ και στα ειδικ για το προϊόν πρτυπα. Σε μια μη συμφωνημένη με την εταιρία μας τροποποίηση των συσκευων αυτ η δηλωση χνει την ισχ της.</p>
<p>DK EU Overensstemmelse certifikat Undertegnede Husqvarna AB, 561 82 Huskvarna, Sweden bekrfter hermed, at enheder listet herunder, ved afsendelse fra fabrikken, er i overensstemmelse med harmoniserede EU retningslinier, EU sikkerheds standarder og produkt specifikations standarder. Dette certifikat trder ud af kraft hvis enhederne er ndret uden vor godkendelse.</p>	<p>SLO EV-izjava o skladnosti Podpisani proizvajalec »Husqvarna AB, 561 82 Huskvarna, Sweden« s podpisom potrjuje, da sledee opisana naprava, ki smo jo poslali na trŹie izpolnjuje zahteve harmoniziranih standardov ES-smernic, ES-varnostnih standardov in izdelku specifinih standardov. V primeru spremembe na napravi brez naega pisnega dovoljenja ta izjava izgubi svoj pomen in veljavnost.</p>
<p>FI EY-vaatimustenmukaisuusvakuutus Allekirjoittanut Husqvarna AB, 561 82 Huskvarna, Sweden vakuuttaa, ett allamainitut laitteet tyttvt tentaaltamme lhtiessn yhdenmukaistettujen EY-direktiivien, EY-turvallisuusstandardien ja tuotekohtaisen standardien vaatimukset. Laitteisiin tehdyt muutokset, joista ei ole sovittu kanssamme, johtavat tmn vakuutuksen raukeamiseen.</p>	<p>RO UE-Certificat de conformitate Prin prezenta Husqvarna AB, 561 82 Huskvarna, Sweden, certifica faptul ca, in momentul in care produsele mentionate mai jos ies din fabrica sunt in concordanta cu directivele UE, standardele de siguranta UE si standardele specifice ale produsului UE. Acest certificat devine nul in cazul modificrii aparatului fr aprobarea noastr.</p>
<p>I Dichiarazione di conformit alle norme UE La sottoscritta Husqvarna AB, 561 82 Huskvarna, Sweden certifica che il prodotto qui di seguito indicato, nei modelli da noi commercializzati,  conforme alle direttive armonizzate UE nonch agli standard di sicurezza e agli standard specifici di prodotto. Qualunque modifica apportata al prodotto senza nostra specifica autorizzazione invalida la presente dichiarazione.</p>	<p>BG ES-Декларация за съответствие Подписанелата фирма Husqvarna AB, 561 82 Huskvarna, Sweden декларира, че описаните по-долу уреди, пуснати в продажба съгласно нашата спецификация, изпълняват изискванията на хармонизираните ЕС-директиви, ЕС-станданти за безопасност и специфичните производствени стандарти. При промяна на уреда, която не е съгласувана с нас, тази декларация губи своята валидност.</p>
<p>E Declaracin de conformidad de la UE El que suscribe Husqvarna AB, 561 82 Huskvarna, Sweden declara que la presente mercancia, objeto de la presente declaracin, cumple con todas las normas de la UE, en lo que a normas tcnicas, de homologacin y de seguridad se refiere. En caso de realizar cualquier modificacin en la presente mercancia sin nuestra previa autorizacin, esta declaracin pierde su validez.</p>	<p>EST ELI vastavusdeklaratsioon Allkirjutanu Husqvarna AB, 561 82 Huskvarna, Sweden kinnitab, et kirjeldatud seade vastab meie poolt riigisuse viidud kujul ELI harmoniseeritud direktiividele, ELI ohutusstandarditele ja tootega seotud standarditele. Meiega koosklstamatata muudatuse tegemise korral seadmel kaotab see deklaratsioon kehtivuse.</p>
<p>P Certificado de conformidade da UE Os abaixo mencionados Husqvarna AB, 561 82 Huskvarna, Sweden Por este meio certificamos que ao sair da fbrica os aparelhos abaixo mencionados esto de acordo com as diretrizes harmonizadas da UE, padres de segurana e de produtos especificos. Este certificado ficar nulo se as unidades forem modificadas sem a nossa aprovao.</p>	<p>LT ES Atitikties deklaracija Pasiraanti firma Husqvarna AB, 561 82 Huskvarna, Sweden patvirtina, kad Źemiau nurodyti prietaisai ir ju modeliai, kuriuos pleidome į prekyb, atitinka harmonizuotas ES direktyvas, ES saugumo standartus ir specifinius gamintojo standartus. Atlikus bet kokį prietaiso pakeitim, kuris nra suderintas su mumis, ši deklaracija praranda galiojim.</p>
	<p>LV ES-atbilstības deklaracija Parakstijies Husqvarna AB, 561 82 Huskvarna, Sweden, Vcija apstiprina, ka sekojoši apzīmētās iekrtas, kuras mēs izplatām, sav izpildījum atbilst harmonizētajām ES direktīvām, ES drošības standartiem un produkta specifiskajiem standartiem. Ar mūsu nepatstiprinātām izmaiņām iekrtā šī deklarācija zaudē savu derīgumu.</p>

<p>Bezeichnung der Geräte: Description of the units: Désignation du matériel : Omschrijving van de apparaten: Produktbeskrivning: Beskrivelse af produktet: Laitteiden nimitys: Descrizione dei prodotti: Descripción de la mercancía: Descrição dos aparelhos: Nazwa urządzenia: A készülékek megnevezése: Označení přístrojů: Označenie zariadenia: Όνομασία της συσκευής: Opis naprave: Descrierea articolelor: Обозначение на уредите:</p> <p>Seadmete nimetus: Prietaisų pavadinimas: Iekārtu apzīmējums:</p>	<p>Hauswasserwerk Pressure Tank Unit Groupe de surpression Hydrofoorpomp Hydroforpump Husvandværk Paineveiyksikkö Autoclave Estación de Bombeo con Calderín Bomba doméstica Zestaw hydroforowy Házi vízellátó Domáci vodárna Domáca vodáreň Πιστικό με βαρέλι Hišna vodna črpalka Hydrofor cu rezervor Хидрофорна уредба с разширителен съд Hidroforiga veeautomaat Siurblys su slėgio rezervuaru Spieđtvertnes ierice</p>	<p>Schall-Leistungspegel: Noise level: Puissance acoustique : Geluidsniveau: Ljudnivá: Lydotryksniváeu: Melun tehotosa: Livello rumorosità: Nivel sonoro: Nivel de ruido: Poziom natężenia dźwięku: Zajteljesítmény szint: Hluková hladina výkonu: Výkonová hladina hluku: Επίπεδο ισχύος ήχου: Nivo hrupa: Nivel de putere acustică: Ниво на шума: Helivõimsuse tase: Garso stiprumo lygis: Trokšņu jaudas līmenis:</p> <p>gemessen / garantiert measured / guaranteed mesurée / garantie gemeten / gearandeerd uppmått / garanterad afmått / garanti mitattu / taattu testato / garantito medido / garantizado medido / garantido zmierzono / gwarantowane mért / garantált naměřeno / garantováno meraná / garantovaná μετρήθηκαν / εγγυημένα izmerjeno / zagotovljeno măsurat / garantat измерено / гарантирано mõõdetud / garanteeritud išmatuotas / garantuotas izmērtais / garantētais</p> <p>1753 78,5 dB (A) / 81 dB (A)</p>
<p>Typ: Type: Type : Type: Typ: Type: Type: Typ: Type: Typ: Type: Type: Typ: Type: Typ:</p> <p>3000/4 eco</p>	<p>Art.-Nr.: Art. No.: Référéncie : Art.nr.: Art.nr.: Art. nr.: Art. no.: Nr artykułu: Čiikkszám: Číslo artiklu:</p> <p>1753</p>	<p>Anbringungsjaar der CE-Kennzeichnung: Year of CE marking: Année d'apposition du marquage CE : Installatiejaar van de CE-aanduiding: Märkningsår: CE-Märkningsår: CE-merkin kiinnitysvuosi: Anno di applicazione della certificazione CE: Colocación del distintivo CE: Ano de marcação pela CE: Rok nadania oznakowania CE: CE-jelzés elhelyezésének éve: Rok umístění značky CE: Rok udelenia značky CE: Έτος σήματος CE: Leto namestitve CE-oznake: Anul de marcare CE: Година на поставяне на CE-маркировка: CE-márgistuse paigaldamise aasta: Metal, kurialis pažymėta CE-ženklu: CE-marķējuma uzlikšanas gads:</p> <p>2013</p>
<p>EU-Richtlinien: EU directives: Directives européennes : EU-richtlijnen: EU directiv: EU Retningslinier: EY-direktiivi: Direttive UE: Normativa UE: Directrizes da UE: Dyrektwyw Unii Europejskiej:</p>	<p>EU-irányelvek: Směrnice EU: EU-Predpisy: Οδηγίες της ΕΕ: ES-smernice: Directive UE: EC-директиви: EU direktiivid: ESi direktivos: ES-direktivas:</p> <p>2006/95/EG 2004/108/EG 2011/65/EG 2000/14/EG</p>	<p>Ulm, den 21.08.2013 Ulm, 21.08.2013 Fait à Ulm, le 21.08.2013 Ulm, 21-08-2013 Ulm, 2013.08.21. Ulm, 21.08.2013 Ulmissa, 21.08.2013 Ulm, 21.08.2013 Ulm, 21.08.2013 Ulm, 21.08.2013 Ulm, dnia 21.08.2013 Ulm, 21.08.2013 Ulm, 21.08.2013 Ulm, 21.08.2013 Ulm, 21.08.2013 Ulm, 21.08.2013 Ulm, 21.08.2013 Ulm, 21.08.2013 Ulm, 21.08.2013 Ulm, 21.08.2013 Ulm, 21.08.2013 Ulm, 21.08.2013</p>
<p>Harmonisierte EN: EN 60335-1 EN 60335-41 EN 55014-1 EN 55014-2 EN 61000-3-11</p>		<p>Der Bevollmächtigte Authorised representative Le mandataire De gevolmachtigde Auktoriserad representant Autoriseret repräsentant Valtuutettu edustaja Persona delegata La persona autorizada O reprezentante Pehnomocnik Meghatalmazott Zplnomocněnc Splnomocnený Ο εξουσιοδοτημένος Pooblaščenec Conducerea tehnică Упълномощен Valitatud esindaja Įgaliotasis atstovas Pilnvarotā persona</p> <p>Reinhard Pompe Vice president</p>
<p>Hinterlegte Dokumentation: GARDENA- Technische Dokumentation, M. Kugler 89079 Ulm</p> <p>Deposited Documentation: GARDENA Technical Documentation, M. Kugler 89079 Ulm</p> <p>Dokumentation déposée: Documentation technique GARDENA, M. Kugler 89079 Ulm</p>	<p>Konformitätsbewertungsverfahren: Nach 2000/14/ EG Art. 14 Anhang V</p> <p>Conformity Assessment Procedure: according to 2000/14/EC Art.14 Annex V</p> <p>Procédure d'évaluation de la conformité: Selon 2000 /14 /CE art. 14 Annexe V</p>	

Deutschland / Germany

GARDENA GmbH
Central Service
Hans-Lorenser-Straße 40
D-89079 Ulm
Produktfragen:
(+49) 731 490-123
Reparaturen:
(+49) 731 490-290
service@gardena.com

Albania

COBALT Sh.p.k.
Rr. Siri Kodra
1000 Tirana

Argentina

Husqvarna Argentina S.A.
Av. del Libertador 5954 –
Piso 11 – Torre B
(C1428ARP) Buenos Aires
Phone: (+54) 11 5194 5000
info.gardena@
ar.husqvarna.com

Armenia

Garden Land Ltd.
61 Tigran Mets
0005 Yerevan

Australia

Husqvarna Australia Pty. Ltd.
Locked Bag 5
Central Coast BC
NSW 2252
Phone: (+61) (0) 2 4352 7400
customer.service@
husqvarna.com.au

Austria / Österreich

Husqvarna Austria GmbH
Consumer Products
Industriezeile 36
4010 Linz
Tel.: (+43) 732 77 01 01-90
consumer.service@
husqvarna.at

Azerbaijan

Firm Progress
a. Aliyev Str. 26A
1052 Baku

Belgium

COGEM Belgium NV/SA
Sterebeekstraat 163
1930 Zaventem
Phone: (+32) 2 70 92 12
Mail: info@gardena.be

Bosnia / Hercegovina

SILK TRADE d.o.o.
Industrijska zona Bukva bb
74260 Tešanj

Brazil

Husqvarna do Brasil Ltda
Av. Francisco Matarazzo,
1400 – 19º andar
São Paulo – SP
CEP: 05001-903
Tel: 0800-112252
marketing.br.husqvarna@
husqvarna.com.br

Bulgaria

Хускарна България ЕООД
Бул. „Андрей Липчев“ № 72
1739 София
Тел.: (+359) 02/9753076
www.husqvarna.bg

Canada / USA

GARDENA Canada Ltd.
100 Summerlea Road
Brampton, Ontario L6T 4X3
Phone: (+1) 905 792 9330
info@gardenacanada.com

Chile

Maquinarias Agroforestales
Ltda. (Maga Ltda.)
Santiago, Chile
Avda. Chesterton
8355 comuna Las Condes
Phone: (+56) 2 202 4417
Dalton@maga.cl
Zipcode: 7560330
Temuco, Chile
Avda. Valparaíso # 01466
Phone: (+56) 45 222 126
Zipcode: 4780441

China

Husqvarna (China) Machinery
Manufacturing Co., Ltd.
No. 1355, Jia Xin Rd.,
Ma Lu Zhen, Jia Ding Dist.,
Shanghai
201801
Phone: (+86) 21 59159629
Domestic Sales
www.gardena.com.cn

Colombia

Husqvarna Colombia S.A.
Calle 18 No. 68 D-31, zona
Industrial de Montevideo
Bogotá, Cundinamarca
Tel. 571 2922700 ext. 105
jairo.salazar@
husqvarna.com.co

Costa Rica

Compania Exim
Euroiberamericana S.A.
Los Colegios, Moravia,
200 metros al Sur del Colegio
Saint Francis – San José
Phone: (+506) 297 68 83
exim_euro@racsca.co.cr

Croatia

SILK ADRIA d.o.o.
Josipa Lončara 3
10090 Zagreb
Phone: (+385) 1 3794 580
silk.adria@zg.t-com.hr

Cyprus

Med Marketing
17 Digeni Akrita Ave
P.O. Box 27017
1641 Nicosia

Czech Republic

Husqvarna Česko s.r.o.
Türkova 2319/5b
149 00 Praha 4 – Chodov
Bezplatná infolinka:
800 100 425
servis@cz.husqvarna.com

Denmark

GARDENA/Husqvarna
Consumer Outdoor Products
Salgsafdelning Danmark
Box 9003
S-200 39 Malmö
info@gardena.dk

Dominican Republic

BOSQUESA, S.R.L
Carretera Santiago Licey
Km. 5 ½
Esquina Copal II,
Santiago, Dominican Republic
Phone: (+809) 736-0333
joserbosquesa@claro.net.do

Ecuador

Husqvarna Ecuador S.A.
Arujos E1-181 y 10 de Agosto
Quito, Pichincha
Tel: (+593) 22800739
francisco.jacom@
husqvarna.com.ec

Estonia

Husqvarna Eesti OÜ
Consumer Outdoor Products
Kesk tee 10, Aaviku küla
Rae vald
Häria maakond
75305 Estonia
kontakt.etj@husqvarna.ee

Finland

Oy Husqvarna Ab
Consumer Outdoor Products
Lautatamankatu 8 B / PL 3
00581 HELSINKI
info@gardena.fi

France

GARDENA France
Immeuble Exposial
9-11 allée des Pierres Mayettes
ZAC des Barbanniers, B.P. 99
- R. 92232 GENNEVILLIERS
cedex
Tel: (+33) 01 40 85 30 40
service.consommateurs@
gardena.fr

Georgia

ALD Group
Belajshvili 8
1159 Tbilisi

Great Britain

Husqvarna UK Ltd
Preston Road
Aycliffe Industrial Park
Newton Aycliffe
County Durham
DL5 6UP
info.gardena@
husqvarna.co.uk

Greece

HUSQVARNA ΕΛΛΑΣ Α.Ε.Β.Ε.
Υπ/μια Ηφαιστίου 33Α
Β. Π.ε. Κορωπίου
194 00 Κορωπί Αττικής
V.A.T. EL.094094640
Phone: (+30) 210 66 20 225
info@husqvarna-consumer.gr

Hungary

Husqvarna Magyarország Kft.
Ezred u. 1-3
1044 Budapest
Telefon: (+36) 1 251-4161
vevoszolgalat.husqvarna@
husqvarna.hu

Iceland

O. Johnson & Kaaber
Tunguhsali 1
110 Reykjavik
ooj@ojk.is

Ireland

Husqvarna UK Ltd
Preston Road
Aycliffe Industrial Park
Newton Aycliffe
County Durham
DL5 6UP
info.gardena@
husqvarna.co.uk

Italy

Husqvarna Italia S.p.A.
Via Como 72
23868 VALMADRERA (LC)
Phone: (+39) 0341.203.111
info@gardenaitalia.it

Japan

KAKUICHI Co. Ltd.
Sumitomo Realty &
Development Kojimachi
BLDG., 8F
5-1 Nibanbanyo
Chiyoda-ku
Tokyo 102-0084
Phone: (+81) 33 264 4721
m_ishihara@kaku-ichi.co.jp

Kazakhstan

LAMED Ltd.
155/1, Tazhibayevoy Str.
050060 Almaty
IP Schmidt
Abayavenue 3B
110 005 Kostanay

Korea

Kyung Jin Trading CO.,LTD.
107-4, SunDuk Bld.,
YangJae-dong,
Seocho-gu,
Seoul, (zipcode: 137-891)
Phone: (+82) (0)2 574-6300

Kyrgyzstan

Alye Maki
av. Moladaya Guardir J 3
720014
Bishkek

Latvia

Husqvarna Latvija
Consumer Outdoor Products
Bākižu iela 6
LV-1024 Riga
info@husqvarna.lv

Lithuania

UAB Husqvarna Lietuva
Consumer Outdoor Products
Tel. (+370) 31 04 85 30 40
service.consommateurs@
gardena.fr

Luxembourg

Magasins Jules Neuberg
39 Rue Jacques Stas
Luxembourg-Gasperich 2549
Case Postale No. 12
Luxembourg 2010
Phone: (+352) 40 14 01
api@neuberg.lu

Mexico

AFOSA
Av. Lopez Mateos Sur # 5019
Col. La Calma 45070
Zapopan, Jalisco
Mexico
Phone: (+52) 33 3818-3434
icornejo@afosa.com.mx

Moldova

Convel S.R.L.
290A Muncești Str.
2002 Chisinau

Netherlands

GARDENA Nederland B.V.
Postbus 50176
1305 AD ALMERE
Phone: (+31) 36 521 00 00
info@gardena.nl

Neth. Antilles

Jonka Enterprises N.V.
Sta. Rosa Weg 196
P.O. Box 8200
Curaçao
Phone: (+599) 9 767 66 55
pgm@jonka.com

New Zealand

Husqvarna New Zealand Ltd.
PO Box 76-437
Manukau City 2241
Phone: (+64) (0) 9 9202410
support.nz@husqvarna.co.nz

Norway

GARDENA
Husqvarna Consumer
Outdoor Products
Salgskontor Norge
Kleiverveien 6
1540 Vestby
info@gardena.no

Peru

Husqvarna Perú S.A.
Jr. Ramón Cárcamo 710
Lima 1
Tel.: (+51) 1 3320400 ext. 416
juan_remu@zooz.com
husqvarna.com

Poland

Husqvarna
Poland Spółka z o.o.
ul. Wysockiego 15 b
03-371 Warszawa
Phone: (+48) 22 330 96 00
gardena@husqvarna.com.pl

Portugal

Husqvarna Portugal, SA
Lagoa – Albaraque
2635 – 595 Rio de Mouro
Tel.: (+351) 21 922 85 30
Fax : (+351) 21 922 85 36
info@gardena.pt

Romania

Madex International Srl
Soseaua Odaii 117 - 123,
RO 013603
Bucuresti, S 1
Phone: (+40) 21 352.76.03
madex@ines.ro

Russia

ООО „Хускарна“
141400, Московская обл.,
г. Химки,
улица Ленинградская,
владение 39, стр.6
Бизнес Центр
„Химки Бизнес Парк“,
помещение 0B02_04

Serbia

Domel d.o.o.
Autoput za Novi Sad bb
11273 Belgrade
Phone: (+381) 118 48 88 12
miroslav.jejina@domel.rs

Singapore

HV-Ray PRIVATE LIMITED
40 Jalan Pampinim
#02-08 Tat Ann Building
Singapore 577185
Phone: (+65) 6253 2277
shivya@hvray.com.sg

Slovak Republic

Husqvarna Česko s.r.o.
Türkova 2319/5b
149 00 Praha 4 – Chodov
Bezplatná infolinka:
800 154 044
servis@sk.husqvarna.com

Slovenia

Husqvarna Austria GmbH
Consumer Products
Industriezeile 36
4010 Linz
Tel.: (+43) 732 77 01 01-90
consumer.service@
husqvarna.at

South Africa

Husqvarna
South Africa (Pty) Ltd
Postnet Suite 250
Private Bag X6
Cascades, 3202
South Africa
Phone: (+27) 33 846 9700
info@gardena.co.za

Spain

Husqvarna España S.A.
C/ Basauri, nº 6
La Florida
28023 Madrid
Phone: (+34) 91 708 05 00
atencioncliente@gardena.es

Suriname

Agrofix n.v.
Verlengde Hogestraat #22
P.O. Box: 2006
Paramaribo
Suriname – South America

Sweden

Husqvarna AB
S-561 82 Huskvarna
info@gardena.se

Switzerland / Schweiz

Husqvarna Schweiz AG
Consumer Products
Industriestrasse 10
5506 Mägenwil
Phone: (+41) (0) 848 800 464
info@gardena.ch

Turkey

GARDENA Dost Diş Ticaret
Müessesilik A.Ş.
Sanayi Cad. Adil Sokak
No: 1/B Kartal
34873 Istanbul
Phone: (+90) 216 38 93 939
info@gardena-dost.com.tr

Ukraine / Україна

ТОВ «Хускарна Україна»
в. Васильківська, 34,
офіс 204-р
03022, Київ
Тел. (+38) 044 998 39 02
info@gardena.ua

Uruguay

FELI SA
Entre Rios 1083 CP 11800
Montevideo – Uruguay
Tel: (+598) 22 03 18 44
info@felisa.com.uy

Venezuela

Corporación Casa y Jardín C.A.
Av. Caroni, Edif. Trezmen, PB.
Colinas de Bello Monte,
1050 Caracas.
Tlf: (+58) 212 992 33 22
info@casayjardin.net.ve

1753-20.960.02/0913
© GARDENA
Manufacturing GmbH
D-89070 Ulm
http://www.gardena.com