

4000/5

Art. 1732

5000/5

Art. 1734

6000/6 inox Art. 1736

D Betriebsanleitung
Gartenpumpe

GB Operating Instructions
Garden Pump

F Mode d'emploi
Pompe de surface pour arrosage

NL Gebruiksaanwijzing
Besproeiingspomp

S Bruksanvisning
Bevattningspump

DK Brugsanvisning
Trykpumpe

FI Käyttöohje
Puutarhapumppu

N Bruksanvisning
Hagepumpe

I Istruzioni per l'uso
Pompa da giardino

E Instrucciones de empleo
Bomba para jardín

P Manual de instruções
Bomba de Jardim

PL Instrukcja obsługi
Pompa ogrodowa

H Használati utasítás
Kerti szivattyú

CZ Návod k obsluze
Zahradní čerpadlo

SK Návod na obsluhu
Záhradné čerpadlo

GR Οδηγίες χρήσης
Αντλία κήπου

RUS Инструкция по эксплуатации
Садовый насос

SLO Navodilo za uporabo
Vrtna črpalka

HR Upute za uporabu
Vrtna pumpa

SRB Uputstvo za rad
BIH Baštenska pumpa

UA Інструкція з експлуатації
Садові насоси

RO Instrucțiuni de utilizare
Pompă de grădină

TR Kullanma Kılavuzu
Bahçe pompası

BG Инструкция за експлоатация
Градинска помпа

AL Manual përdorimi
Pompë kopshti

EST Kasutusjuhend
Aiapump

LT Eksploatavimo instrukcija
Sodo siurblys

LV Lietošanas instrukcija
Dārza sūkņis

GARDENA Garden Pump

4000/5 / 5000/5 / 6000/6 inox



Translation of the original German operating instructions.

Please read the operating instructions carefully and observe the notes given. Use these operating instructions to familiarise yourself with the product, the proper use and the safety instructions.



Never operate the product when you are tired, ill or under the influence of alcohol, drugs or medicine.

This product may be used under supervision, or if instruction regarding the safe use of the product has been provided and the resulting dangers have been understood, by children aged 8 and above, as well as by persons with physical, sensory or mental disabilities or a lack of experience and knowledge. Children must not be allowed to play with the product. Cleaning and user maintenance must not be performed by children without supervision. The use of this product by young people under the age of 16 is not recommended.

→ Keep these operating instructions in a safe place.

Contents:

1. Area of application of your GARDENA Garden Pump	13
2. Safety Instructions	14
3. Initial Operation	15
4. Operation	16
5. Storage	18
6. Maintenance	18
7. Trouble-Shooting	19
8. Available accessories	21
9. Technical Data	21
10. Service/Warranty	22

1. Area of application of your GARDENA Garden Pump

Purpose:

The GARDENA Garden Pump is designed for domestic use around the house and garden.

When the pump is used for pressure boosting, the maximum permissible internal pressure of 6 bar (on the delivery side) must not be exceeded. The increased delivery pressure and the pump pressure have to be added together.

- Example: Pressure at the tap = 1.5 bar, maximum pressure of the Garden Pump 4000/5 = 4.5 bar, total pressure = 6.0 bar.

Liquids that can be pumped:

The GARDENA Garden Pump can be used for pumping ground water and rain water, tap water and swimming pool water containing chlorine.

Please note:



The GARDENA Garden Pump is not suitable for continuous operation (e.g. industrial applications, continuous circulating operation). Corrosive, easily combustible, aggressive or explosive liquids (such as gasoline, petroleum or nitro thinner), saltwater and food must not be pumped. The temperature of the liquid must not exceed 35 °C.

2. Safety Instructions



DANGER! Electric shock!

Risk of injury due to electric shock.

→ Always unplug your Garden Pump before filling, after operation, when trouble-shooting and before carrying out any maintenance work.



RISK OF INJURY!

Hot water – risk of scalding!

For pump 4000/5 only: If the pump is operated for prolonged periods of time (> 5 min.) with the delivery side closed, the water in the pump may heat up so that there is a risk of scalding yourself with hot water.

→ The pump should not run against the closed delivery side for more than 5 minutes.

If the water supply on the intake side of the pump fails, the water in the pump can heat up so that if water emerges, injuries could be caused by the hot water.

→ **Disconnect the pump from the mains via the main circuit breaker, let the water cool and secure the suction-side water supply before putting into operation again.**

Location

The pump must be supplied through a residual current device (RCD) having a rated residual operating current not exceeding 30 mA. The pump must not be operated when there are persons in the swimming pool or garden pond. The pump must be located on solid, even ground, protected from flooding. Take care that the pump cannot fall into water. Position the pump at a safe distance (min. 2 m) from the liquid to be pumped. As an additional safety device an authorised safety switch can be used.

→ Please ask your electrician for his advice.

When connecting the pump to the water supply system, the country-specific sanitary regulations

must be observed to prevent water not of drinking water quality being drawn back in.

→ Please consult a specialist for sanitary installations.

Extension cables

Date indicated on the type plate must match technical data of the mains supply.

Only use extension cables authorised in accordance with HD 516.

→ Consult your qualified electrician.

→ Don't use the power cable for carrying the pump or for plugging off.

In Austria

In Austria, the electrical connections must be made according to ÖVE-EM 42, T2 (2000)/1979 § 22 based on § 2022. Pursuant to this regulation it's imperative to operate pumps for swimming pools and garden ponds exclusively via an isolating transformer.

→ Please ask your electrician.

In Switzerland

In Switzerland mobile appliances which are used outdoors, must be connected via a residual-current device.

Visual check

→ Before operating the pump, first make a visual check, if there is any damage of the pump (esp. regarding power cable and plug).

A damaged pump must not be used.

→ In case of damage, please have the pump checked by our GARDENA Service Centre or by an authorised electrician.

→ A damaged connection cable may only be exchanged by GARDENA Service or an authorised electrician.

Note

→ Protect the pump from rain. Don't use the pump in wet or moist area.

In order to avoid dry-running of the pump, take care that the end of the suction hose is always submerged into the liquid.

→ Before each operation, fill the pump to overflowing with approx. 2 to 3 l of the liquid to be pumped!

Sand and other abrasive substances in the liquid cause in-creased wear and reduce the pump's output.

Pumping dirty water, e.g. stones, pine needles etc., can cause damage to the pump.

→ Do not pump dirty water.

The minimum flow rate is: 4000/5: 90 l/h (= 1.5 l/min); 5000/5: 200 l/h (= 3.3 l/min).
Watering accessories with lower rate must not be operated.

Warning! This machine produces an electromagnetic field during operation. This field may under some circumstances interfere with active or passive medical implants. To reduce the risk of serious or fatal injury, we recommend persons with medical implants to consult their physician and the medical implant manufacturer before operating this machine.

Danger! Small parts could be swallowed during assembly and there is a risk of suffocation from the polybag. Keep infants away during assembly.

3. Initial Operation

Setting up your Garden Pump: The site must be firm and solid in order to ensure safe and sturdy operating conditions for the pump.

→ Position the pump at a safe distance (min. 2 m) from the liquid to be pumped.

The pump must be installed in a location with low air humidity and sufficient ventilation in the area of the ventilation slots. It must be at a distance of at least 5 cm from the walls. No dirtcontamination (e.g. sand or earth) may be sucked in through the ventilation slots.

Connecting hose to suction side:

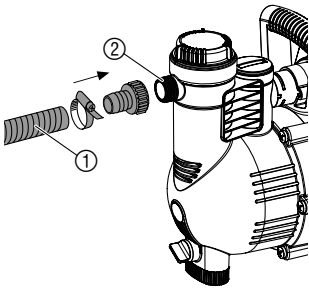

Don't use any hose connection system fittings on the suction side! A vacuum-resistant suction hose must be used, e. g. **GARDENA Suction Unit, art. no. 1411**.

In order to reduce the suction time, it is advisable to use a suction hose with backflow preventer avoiding automatic draining of the suction hose when the pump is stopped.

1. Screw a vacuum-resistant suction hose ① airtight onto the connector on the suction side of the pump ②.
2. For suction heights exceeding 4 m also secure the suction hose ① (e.g. by fastening it to a wooden post).
This relieves the pump of the weight of the suction hose.

Connecting hose to delivery side:

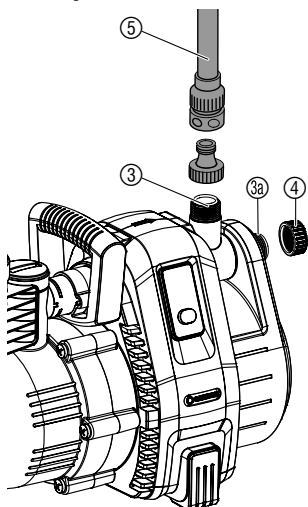

The pumps have 2 connections (3/3a) on the delivery side. The pump connection not in use has to be closed by the cap (4), which can be unscrewed for connecting 2 hoses.

The pump connections (3/3a) are equipped with a 33.3 mm (G 1") thread which can be used to connect 13 mm (1/2"), 16 mm (5/8") or 19 mm (3/4") hoses via the GARDENA hose connection system.

Optimised use of the pump capacity is achieved by connecting 19 mm (3/4") hoses with e.g. GARDENA Pump Connection Set Art. 1752, or by connecting 25 mm (1") hoses with **GARDENA Quick Thread Coupling with female thread Art. 7109/Quick Coupling Hose Connector Art. 7103**.

→ Connect the pressure hose (5) to the connector on the delivery side (3/3a).

If more than 2 hoses/ accessories are connected simultaneously, we recommend using the **GARDENA 2- or 4-Channel Water Distributor Art. 8193/8194**, **GARDENA Twin-Tap Connector Art. 940** which can be screwed directly onto the connection on the delivery side (3/3a).

4. Operation

Filling the pump:



DANGER! Electric shock!

Risk of injury due to electric shock.

→ Disconnect from the mains before filling the Garden Pump.



ATTENTION!

→ Before each operation, slowly fill the pump with liquid to be pumped until it overflows (approx. 2 to 3 l).

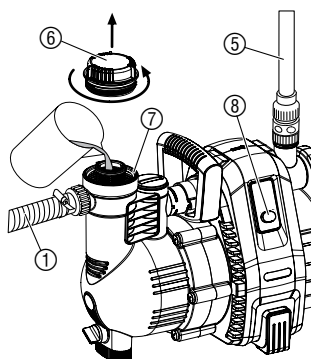

1. Open the cap (6) on the filler neck (7) by hand.
2. Fill the pump via the filler cap (7) to overflowing with approx. 2 to 3 l of the liquid to be pumped.
3. Tighten the cap (6) of the filler cap (7) by hand (do not use pliers).
4. Open any shut-off valves in the delivery line (accessories, water stop, etc.).
5. Drain remaining water in pressure hose (5) so that air can escape during the suction process.
6. **Switching on pump 4000/5:** Lift and hold the delivery hose (5) at least 1 m vertically above the pump, press the On/Off switch (8) (*On/Off switch shines*) and wait until the pump has primed.

→ If the pump does not deliver after approx. 5 minutes, switch off the pump (press On/Off switch (8) (see 7. Trouble-Shooting)).

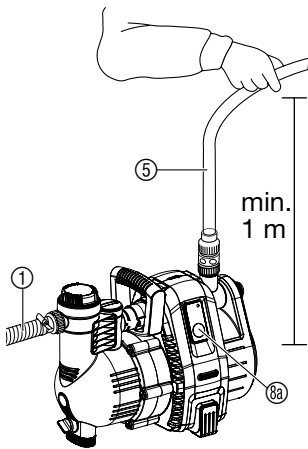

6. **Switching on pump 5000/5; 6000/6 inox:**
Lift and hold the delivery hose (5) at least 1 m vertically above the pump, insert the power plug, press the On/Off button (8a) (the LED shines green) and wait until the pump has primed.

If the pump does not deliver within approx. 20 seconds, the LED flashes orange.

If the pump does not deliver: 5000/5 within approx. 5 minutes / 6000/6 inox within approx. 6 minutes, the LED shines red and the pump switches off automatically (see "7. Trouble-Shooting").

→ **If the pump does not automatically switch off then manually switch the pump off and check the hose for leaks.**

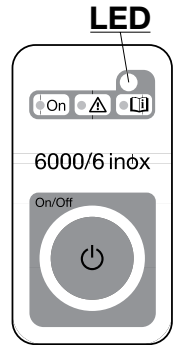

Special mode:

The specified maximum self-priming suction height of 8 m is reached only if the pump is filled via the filler neck (7) up to the overflow and if, while doing so and during the self-priming, the delivery hose (5) is held up sufficiently high to prevent any flow medium escaping from the pump via the delivery hose (5).

Additional electrical switching devices (e.g. remote control systems, pressure switches) can be used only in the special mode.

Activating the special mode:

1. When switching on, press the On/Off button (8a) for 8 seconds.
During the first 5 seconds, the green LED is illuminated; then the LED blinks for 3 seconds.
2. When the green LED illuminates again after 8 seconds, let go of the On/Off button (8a).

Deactivating the special mode:

1. Plug the mains plug into an energised mains socket.
The pump starts of its own accord.
2. Press the On/Off button (8a). *The pump switches off.*
3. When switching on, keep the On/Off button (8a) depressed for 8 seconds until the green LED no longer flashes.

safe-pump-function:

The **safe-pump function** uses the LED status display to alert the user that there is no water flow. In addition, it acts as **Dry-Run-Safety**, guarding against pump damage if the delivery side is closed too long (e.g. closed valves) or if the water supply fails (e.g. empty cistern).

LED flashes green: Normal operation

LED flashes orange: No water flow for at least 20 seconds

LED shines red: No water flow for at least 5 minutes (pump has switched off automatically)

LED flashes red: Alarm! Pump was started 3 times within 20 min. without water flow. (Pump can no longer be started for 5 min. to allow cooling, after which the LED shines red)

5. Storage

To put into storage:

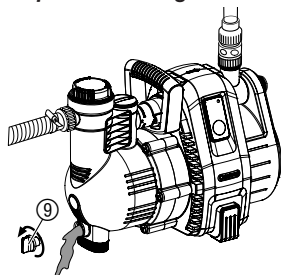

Disposal:
(in accordance with
RL 2012/19/EU)



Before the start of the frost period the Garden Pump should be stored protected from frost.

1. Open the water drain screw ⑨.
The Garden Pump drains.
2. Store your Garden Pump so that it is protected from frost.

The product must not be added to normal household waste. It must be disposed of in line with local environmental regulations.

6. Maintenance



DANGER! Electric shock!

Risk of injury due to electric shock.

→ **Disconnect Garden Pump from the mains before carrying out maintenance.**

Cleaning the filter:

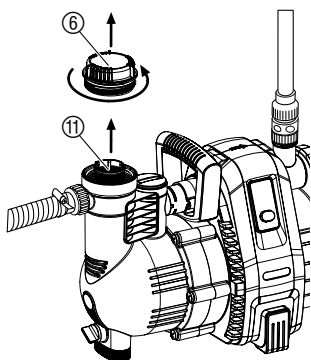

If the filter is dirty it has to be cleaned.

1. Close all shut-off valves, if any, on the suction side.
2. Unscrew and remove cover ⑥ of the filter chamber.
3. Draw out filter unit vertically upwards.
4. Hold beaker ⑩ firmly, turn filter ⑪ anti-clockwise 1 and draw out 2 (bayonet fitting).
5. Clean beaker ⑩ under running water and clean the filter ⑪ e. g. with a soft brush.
6. Refit filter again in reverse order.

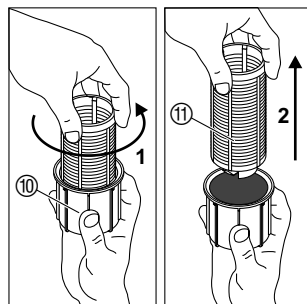

Flush through Garden Pump:

The pump must be flushed through after discharging chlorinated swimming pool water.

1. Pump through lukewarm water (max. 35 °C), possibly adding a mild cleaning agent (e.g. detergent) until the pumped water runs clear.
2. Remove residuals according to the waste disposal laws applicable in your area.



DANGER! Electric shock!

Risk of injury due to electric shock.

→ **Disconnect Garden Pump from the mains before trouble-shooting.**

Free the impeller:

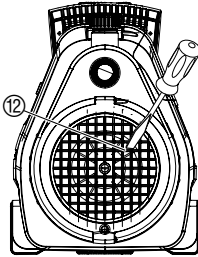

An impeller blocked by dirt can be freed again.

→ Turn the impeller bolt (12) using a screwdriver.
This will free the blocked impeller.

Cleaning the flow sensor:

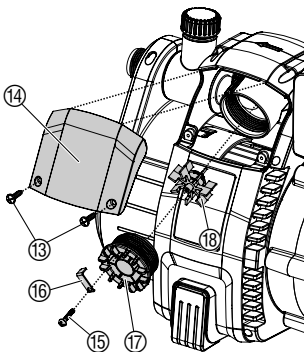

If the flow sensor is dirty, this may result in spurious error messages (LED flashes orange).

1. Unscrew both screws (13).
2. Remove the cover (14).
3. Undo the screw (15) and detach the clip (16).
4. Unscrew the cap (17) anticlockwise.
5. Remove the impeller (18) and clean it. Clean the housing of the flow sensor.
6. Re-fit the impeller (18) with the metal part in the mounting direction.
7. Screw the cap (17) into place clockwise.
8. Secure the cap (17) by way of the clip (16) using the screw (15).
9. First insert the cover (14) at the top and then tighten the two screws (13) at the bottom.

Problem

Pump runs, but the suction action doesn't take place

Possible Cause

Remedy

Pump sucks in air at a joint.	→ Seal connections on suction side so are airtight.
Leaky or damaged suction hose.	→ Check suction line for damage and seal so is airtight.
The pump was not filled with the liquid to be pumped.	→ Fill the pump (see "4. Operation").
The liquid escapes over the hose which is connected to the delivery side during the suction action.	<ol style="list-style-type: none"> 1. Fill the pump again (see "4. Operation"). 2. When starting operation hold the pressure hose approx. 1 m vertically above the pump, until the suction action has taken place.

Absolutely vacuum-resistant connection is achieved by using GARDENA Suction Hoses (see point "8. Available accessories").

Problem

Pump runs, but the suction action doesn't take place

Possible Cause

Remedy

Leaky screw fitting ⑥ at the filler cap ⑦.	→ Check seal (replace if necessary) and tighten connection securely (do not use pliers).
Air cannot escape, since delivery side is closed or remaining water is in the pressure hose.	→ Open shut-off valves (e. g. nozzle) in the delivery line, empty the delivery hose or disconnect it from the pump during priming.
The waiting time wasn't observed.	→ Switch on the pump and wait up to 5 min.
Suction filter or backflow preventer in the suction hose clogged.	→ Clean the filter or the backflow preventer.
Too high suction height.	→ Reduce suction height.
In case of any other difficulties concerning the suction action, use GARDENA Suction Hoses with Backflow Preventer (see point "8. Available accessories") and fill in the liquid to be pumped over the filler cap ⑦ before operation.	

Pump motor runs, but delivery capacity or pressure suddenly decreases

Suction filter at the suction hose is sucked free.	→ Reduce flow rate on the delivery side with a control valve, e.g. GARDENA art. no. (2)977.
Suction filter or backflow preventer clogged.	→ Clean filter or back-flow preventer.
Leaks at suction side.	→ Eliminate leak.
Impeller blocked.	→ Release impeller.

Pump motor doesn't start or suddenly stops

No power.	→ Check fuses and electric connections.
Circuit breaker has switched off the motor due to overheating/ overload.	→ Ensure sufficient cooling/ ventilation and clean the impeller chamber.
Electric failure.	→ Send the pump to one of our GARDENA Service Centres.

5000/5; 6000/6 inox: Pump delivers and LED flashes orange

The flow sensor is dirty.	→ Clean the flow sensor.
---------------------------	--------------------------

5000/5; 6000/6 inox: Pump switches off and the LED shines red

No supply of fluid to be pumped for approx. 5 minutes/ leakage on the suction side.	→ Establish supply of fluid to be pumped/check suction line and re-start pump.
The pump ran for approx. 5 minutes against the closed delivery side.	→ Open the delivery side and re-start pump.



For any other malfunctions please contact the GARDENA service department. Repairs must only be carried out by GARDENA service departments or specialist dealers authorised by GARDENA.

8. Available accessories

GARDENA Suction Hoses	Kink-proof and vacuum-proof, optionally available by the metre Art. no. 1720/1721 (19 mm (3/4")-/25 mm (1")) without connecting fittings or in fixed length Art. no. 1411/1418 complete with connecting fittings.	
GARDENA Suction Hose Fitting	For connection on the suction side.	Art. no. 1723/1724
GARDENA Pump Connection Set	For connection on the delivery side.	Art. no. 1750/1752
GARDENA Suction Filter with backflow preventer	To equip suction hoses with backflow preventer sold by the metre.	Art. no. 1726/1727/1728
GARDENA Electronic Manometric Switch	Automatically cuts in and out the pump depending on the current operating pressure. With dry-running safety. It must be installed at one of the two outlets. (In the case of Art. No. 1734/1736 the special mode has to be activated for this purpose).	Art. no. 1739
For pump 4000/5: GARDENA Dry-Running Safety	Prevents the pump from damages in case of missing liquid.	Art. no. 1741
GARDENA Bore Hole Suction Hose	For vacuum-resistant connection of the pump to boreholes or pipe networks. Length 0.5 m. With 33.3 mm (G1) female thread at both ends.	Art. no. 1729

9. Technical Data

Type	4000/5 (art. no. 1732)	5000/5 (art. no. 1734)	6000/6 inox (art. no. 1736)
Rated power	1,100 W	1,300 W	1,300 W
Max. delivery capacity	4,000 l/h	5,000 l/h	6,000 l/h
Max. pressure/max. delivery head	4.5 bar/45 m	5.0 bar/50 m	5.5 bar/55 m
Max. self-priming suction height	8 m	8 m	8 m
Perm. internal pressure (delivery side)	6 bar	6 bar	6 bar
Voltage/Frequency	220 – 240 V AC/50 Hz	220 – 240 V AC/50 Hz	220 – 240 V AC/50 Hz
Connection cable	1.5 m; H07RN-F	1.5 m; H07RN-F	1.5 m; H07RN-F
Weight	11 kg	11.5 kg	13.5 kg
Noise level $L_{WA}^{1)}$	measured 79 dB (A) guaranteed 82 dB (A)	measured 77 dB (A) guaranteed 80 dB (A)	measured 75 dB (A) guaranteed 79 dB (A)

¹⁾ Measuring method according to directive 2000/14/EC

10. Service/Warranty

Warranty:

GARDENA guarantees this product for 2 years (from date of purchase). This guarantee covers all serious defects of the unit that can be proved to be material or manufacturing faults. Under warranty we will either replace the unit or repair it free of charge if the following conditions apply:

- The unit must have been handled properly and in keeping with the requirements of the operating instructions.
- Neither the purchaser or a non-authorized third party have attempted to repair the unit.

The impeller is a wearing part and is excluded for the warranty.

This manufacturer's guarantee does not affect the user's existing warranty claims against the dealer/seller.

If you have any problems with this product, please contact our Service or return the defective unit together with a short description of the problem – in case of guarantee, with a copy of the receipt – postage paid to one of the GARDENA Service Centres listed on the back of this leaflet.

D Produkthaftung

Wir weisen ausdrücklich darauf hin, dass wir nach dem Produkthaftungsgesetz nicht für durch unsere Geräte hervorgerufene Schäden einzustehen haben, sofern diese durch unsachgemäße Reparatur verursacht oder bei einem Teileaustausch nicht unsere originale GARDENA Teile oder von uns freigegebene Teile verwendet wurden und die Reparatur nicht vom GARDENA Service oder dem autorisierten Fachmann durchgeführt wird. Entsprechendes gilt für Ergänzungssteile und Zubehör.

GB Product Liability

We expressly point out that, in accordance with the product liability law, we are not liable for any damage caused by our units if it is due to improper repair or if parts exchanged are not original GARDENA parts or parts approved by us, and, if the repairs were not carried out by a GARDENA Service Centre or an authorised specialist. The same applies to spare parts and accessories.

F Responsabilité

Nous vous signalons expressément que GARDENA n'est pas responsable des dommages causés par ses appareils, dans la mesure où ces dommages seraient causés suite à une réparation non conforme, dans la mesure où, lors d'un échange de pièces, les pièces d'origine GARDENA n'auraient pas été utilisées, ou si la réparation n'a pas été effectuée par le Service Après-Vente GARDENA ou l'un des Centres SAV agréés GARDENA. Ceci est également valable pour tout ajout de pièces et d'accessoires autres que ceux préconisés par GARDENA.

NL Productaansprakelijkheid

Wij wijzen er nadrukkelijk op, dat wij op grond van de wet aansprakelijkheid voor producten niet aansprakelijk zijn voor schade ontstaan door onze apparaten, indien deze door onvakkundige reparatie veroorzaakt zijn, of er bij het uitwisselen van onderdelen geen gebruik gemaakt werd van onze originele GARDENA onderdelen of door ons vrijgegeven onderdelen en de reparatie niet door de GARDENA technische dienst of de bevoegde vakman uitgevoerd werd. Ditzelfde geldt voor extra-onderdelen en accessoires.

S Produktansvar

Tillverkaren är inte ansvarig för skada som orsakats av produkten om skadan beror på att produkten har reparerats felaktigt eller om, vid reparation eller utbyte, andra än Original GARDENA reservdelar har använts. Samma sak gäller för kompletteringsdelar och tillbehör.

DK Produktansvar

Vi gør udtrykkeligt opmærksom på, at vi i henhold til produktansvarsloven ikke er ansvarlige for skader forårsaget af vores udstyr, såfremt det sker på grund af uautoriserede reparationer eller hvis dele er skiftet ud og der ikke er anvendt originale GARDENA dele eller dele godkendt af os, eller hvis reparationerne ikke er udført af GARDENA-service eller en autoriseret fagmand. Det samme gælder for ekstra udstyr og tilbehør.

FI Tuotevastuu

Korostamme nimenomaan, että tuotevastuulain nojalla emme ole vastuussa laitteistamme johtuneista vahingoista, mikäli nämä ovat aiheutuneet epäasianmukaisesta korjauksesta tai osia vaihdettaessa ei ole käytetty alkuperäisiä GARDENA-varaosia tai hyväksymiämme osia ja korjauksen on suorittanut muu kuin GARDENA-huoltokeskus tai valtuuttamamme ammattihenkilö. Tämä pätee myös lisäksiin ja lisävarusteisiin.

I Responsabilità del prodotto

Si rende espressamente noto che, conformemente alla legislazione sulla responsabilità del prodotto, non si risponde di danni causati da nostri articoli se originati da riparazioni eseguite non correttamente o da sostituzioni di parti effettuate con materiale non originale GARDENA o comunque da noi non approvato e, in ogni caso, qualora l'intervento non venga eseguito da un centro assistenza GARDENA o da personale specializzato autorizzato. Lo stesso vale per le parti complementari e gli accessori.

E Responsabilidad de productos

Advertimos que conforme a la ley de responsabilidad de productos no nos responsabilizamos de daños causados por nuestros aparatos, siempre y cuando dichos daños hayan sido originados por arreglos o reparaciones indebidas, por recambios con piezas que no sean piezas originales GARDENA o bien piezas no autorizadas por nosotros, así como en aquellos casos en que la reparación no haya sido efectuada por un Servicio Técnico GARDENA o por un técnico autorizado. Lo mismo es aplicable para las piezas complementarias y accesorios.

P Responsabilidade sobre o produto

Queremos salientar que segundo a lei da responsabilidade do fabricante, nós não nos responsabilizaremos por danos causados pelo nosso equipamento, quando estes ocorrerem em decorrência de reparações inadequadas ou da substituição de peças por peças não originais da GARDENA, ou peças não autorizadas.

A responsabilidade tornar-se-à nula também depois de reparações realizadas por oficinas não autorizadas pela GARDENA. Esta restrição valerá também para peças adicionais e acessórios.

PL Odpowiedzialność za produkt

Zwracamy Państwu uwagę, że nie ponosimy odpowiedzialności za uszkodzenia naszych maszyn, bądź szkody spowodowane ich wadliwym funkcjonowaniem, powstałe na skutek nieprawidłowo przeprowadzonych napraw lub użycia nieoryginalnych części zamiennych. Naprawy winny być przeprowadzane tylko przez punkty serwisowe Husqvarna lub autoryzowane serwisy. Dotyczy to również części uzupełniających i oprzyrządowania.

H Termékszavatosság

Nyomatékosan utalunk arra a tényre, hogy a termékszavatossági törvény szerint nem kell jótállást vállalnunk azokra a károkra, amelyeket nem a mi készülékeink okoztak, ha ezeket álszzerűtlen javítás okozta vagy egy alkatrész kicserélésénél nem a mi eredeti GARDENA alkatrészeinket vagy általunk engedélyezett alkatrészeket használtak fel és a javítást nem a GARDENA szerviz vagy egy erre felhatalmazott szakember végezte. Hasonlóképpen érvényes ez a kiegészítő alkatrészekre és tartozékokra is.

CZ Odpovědnost za výrobek

Výslovně upozorňujeme na to, že podle zákona o odpovědnosti za výrobek neneseme odpovědnost za škody způsobené našimi přístroji, pokud byly způsobené neodbornou opravou nebo použitím jiných než našich originálních náhradních dílů GARDENA nebo námi schválených dílů a neprovedením opravy servisem GARDENA nebo autorizovaným odborníkem. Odpovídající platí i pro doplňkové díly a příslušenství.

SK Predmet záruky

Upozorňujeme dôrazne na to, že podľa zákona o poskytovaní záruk nezodpovedáme za škody spôsobené našimi výrobkami, v prípade, že boli boli vyvolané neodbornými opravami, výmenou dielcov, ktoré nepatria k originálnym dielom GARDENA alebo neboli nami schválené a rovnako boli spôsobené servisnými zásahmi, ktoré neboli vykonané servisom GARDENA alebo autorizovaným odborníkom. Rovnako to platí pre doplnky a príslušenstvo.

GR Ευθύνη για το προϊόν

Σας υπενθυμίζουμε ρητά, ότι σύμφωνα με το νόμο περί ευθύνης για τα προϊόντα δεν ευθυνόμαστε για ενδεχόμενες βλάβες που προκαλούνται από τις συσκευές μας, εφόσον οφείλονται σε μία ακατάλληλη επισκευή ή σε μια αντικατάσταση τμημάτων για την οποία δεν έχουν χρησιμοποιηθεί τα πρωτότυπα ανταλλακτικά της GARDENA ή τα από μας εγκεκριμένα ανταλλακτικά και σε περίπτωση που δεν εκτελείται η επισκευή από το Τμήμα Εξυπηρέτησης Πελατών της GARDENA ή από έναν εξουσιοδοτημένο εξειδικευμένο τεχνίτη. Το ίδιο ισχύει για εξαρτήματα και συμπληρωματικά τμήματα.

SLO Jamstvo za izdelek

Pismo poudarjamo, da po zakonu jamstva za izdelek nismo odgovorni za škodo, ki bi nastala zaradi uporabe našega izdelka, prav tako tudi ne za škodo ki bi nastala zaradi nepravilnega popravila izdelka ali pri napačni zamenjavi delov, ki niso originalni deli GARDENA ali pri uporabi z naše strani potrjenih delov, ki pa niso bili vgrajeni v servisu GARDENA ali v naši pooblašteni servisni službi. Enako velja tudi za nadomestne dele in opremo.

HR Odgovornost za proizvod

Izričito napominjemo da u skladu sa Zakonom o odgovornosti za proizvode nismo odgovorni za štete uzrokovane našim uređajima ako su one izazvane nestručnim popravkom ili u slučaju zamjene dijelova nisu korišteni originalni GARDENA dijelovi ili dijelovi koje smo odobrili i popravak nije izvršio GARDENA servis ili ovlašteni stručnjak. Isto vrijedi i za dodatne dijelove i pribor.

RO Responsabilitatea legala a produsului

Menționăm în mod expres ca, în concordanță cu responsabilitatea legală a produsului, nu suntem răspunzători de nici un accident provocat de produsele noastre dacă se datorează reparării necorespunzătoare sau dacă piesele de schimb nu sunt originale GARDENA sau aprobate de GARDENA, sau dacă reparațiile nu au fost efectuate de un Centru de Service GARDENA sau un specialist autorizat. Aceleași prevederi se aplică și pieselor de schimb și accesoriilor.

BG Отговорност за качество

Изрично подчертаваме, че съгласно закона за отговорност за качество, ние не носим отговорност за вредите причинени от нашите уреди, ако същите са причинени от неправилен ремонт или при подмяната на части не са използвани оригинални части на GARDENA или части одобрени от нас и ремонта не е извършен от сервиз на GARDENA или оторизиран специалист. Същото важи за допълнителните части и принадлежности.

EST Tootevastutus

Juhime teie tähelepanu sellele, et tootevastutusseaduse kohaselt ei vastuta me meie seadmete poolt põhjustatud kahjude eest, kui need on tekkinud asjatundmatu paranduse tagajärjel või kui detaili vahetamisel ei kasutatud GARDENA originaalvaruosi ega meie poolt kasutada lubatud varuosia ja kui parandustöid ei ole teinud GARDENA klienditeenindusspetsialistid ega meie volitatud spetsialistid. Sama kehtib lisadetailide ja tarvikute kohta.

LT Atsakomybė už produkciją

Nurodome, kad remdamiesi Atsakomybės už produkciją įstatymu, neatsakome už nuostolius, sukeltus mūsų prietaisy, jei jie atsirado dėl netinkamo remonto, arba, jei keičiant dalis, buvo naudojamasi neoriginalios GARDENA dalys arba dalys, kurių mes neleidome naudoti, o remontą atliko ne GARDENA servisas arba neįgaliotasis specialistas. Tas pats galioja papildomoms dalims ir priedams.

LV Produkta atbildība

Mēs skaidri norādām uz to, ka saskaņā ar Produktu atbildības likumu, mēs neatbildam par mūsu iekārtu radītiem zaudējumiem, ciktāl tos ir izraisījis neatbilstošs remonts vai daļu nomaiņa ar neoriģinālām GARDENA daļām vai ne ar mūsu norādītajām detaļām un remontu nav veicis GARDENA serviss vai pilnvarots speciālists. Tas pats attiecas uz papildinošajām daļām un piederumiem.

<p>D EG-Konformitätserklärung Der Unterzeichnete Husqvarna AB, 561 82 Huskvarna, Sweden bestätigt, dass die nachfolgend bezeichneten Geräte in der von uns in Verkehr gebrachten Ausführung die Anforderungen der harmonisierten EU-Richtlinien, EU-Sicherheitsstandards und produktspezifischen Standards erfüllen. Bei einer nicht mit uns abgestimmten Änderung der Geräte verliert diese Erklärung ihre Gültigkeit.</p>	<p>H EU-Megfelelőeségi nyilatkozat Alulírott, a Husqvarna AB, 561 82 Huskvarna, Sweden igazolja azt, hogy az alábbiakban megnevezett készülékek, az általunk forgalomba hozott kivételben teljesítik a harmonizációs EU-irányelvek, az EU biztonsági szabványok és a termékre jellemző szabványok követelményeit. Ha a készülékeken a mi beleegyezésünk nélkül változtatást végeznek, akkor ez a nyilatkozat érvényét veszti.</p>
<p>GB EU Declaration of Conformity The undersigned Husqvarna AB, 561 82 Huskvarna, Sweden hereby certifies that, when leaving our factory, the units indicated below are in accordance with the harmonised EU guidelines, EU standards of safety and product specific standards. This certificate becomes void if the units are modified without our approval.</p>	<p>CZ Prohlášení o shodě EU Podepsaný Husqvarna AB, 561 82 Huskvarna, Sweden potvrzuje, že dále uvedené přístroje v námi do provozu uvedeném provedení splňují požadavky harmonizovaných směrnic EU, bezpečnostních norem EU a norem specifických pro výrobek. Při námi neschválené změně přístrojů ztrácí toto prohlášení platnost.</p>
<p>F Certificat de conformité aux directives européennes Le constructeur, soussigné : Husqvarna AB, 561 82 Huskvarna, Sweden déclare qu'à la sortie de ses usines le matériel neuf désigné ci-dessous étai conforme aux prescriptions des directives européennes énoncées ci-après et conforme aux règles de sécurité et autres règles qui lui sont applicables dans le cadre de l'Union européenne. Toute modification portée sur ce produit sans l'accord express de GARDENA supprime la validité de ce certificat.</p>	<p>SK EU-Vyhlasenie o zhode Nižšie uvedená firma Husqvarna AB, 561 82 Huskvarna, Sweden vyhlasuje, že uvedené zariadenia, ktoré uviedla na trh v tomto vyhotovení, spĺňajú požiadavky harmonizovaných smerníc EU, bezpečnostných noriem EU a noriem špecifických pre výrobok. Pri zmene zariadenia, ktorá nebola odsúhlasená výrobcom stráca toto vyhlásenie platnosť.</p>
<p>NL EU-overeenstemmingsverklaring Ondergetekende Husqvarna AB, 561 82 Huskvarna, Sweden bevestigt, dat de volgende genoemde apparaten in de door ons in de handel gebrachte uitvoering voldoen aan de eis van, en in overeenstemming zijn met de EU-richtlijnen, de EU-veiligheidsstandaard en de voor het product specifieke standaard. Bij een niet met ons afgestemde verandering aan de apparaten verliest deze verklaring haar geldigheid.</p>	<p>GR Δήλωση Συμμόρφωσης προς τις Οδηγίες της ΕΕ Η υπογράφουσα Husqvarna AB, 561 82 Huskvarna, Sweden δηλώνει, ότι τα εξής αναφερόμενα εκδοόμενα από την εταιρία μας προϊόντα ανταποκρίνονται σε όλες τις εναρμονισμένες προδιαγραφές της ΕΕ, στα πρότυπα ασφαλείας της ΕΕ και στα ειδικά για το προϊόν πρότυπα. Σε μία μη συμφωνημένη με την εταιρία μας τροποποίηση των συσκευών αυτή η δήλωση χάνει την ισχύ της.</p>
<p>S EU Tillverkarintyg Undertecknad firma Husqvarna AB, 561 82 Huskvarna, Sweden intygar härmed att nedan nämnda produkter överensstämmer med EU:s direktiv, EU:s säkerhetsstandard och produktspecifikation. Detta intyg upphör att gälla om produkten ändras utan vårt tillstånd.</p>	<p>SLO EU-izjava o skladnosti Podpisani proizvajalca «Husqvarna AB, 561 82 Huskvarna, Sweden» s podpisom potrjuje, da sledeće opisana naprava, ki smo jo poslali na tržišče izpolnjuje zahteve harmoniziranih standardov ES-smernic, ES-varnostnih standardov in izdelku specifičnih standardov. V primeru spremembe na napravi brez našega pisnega dovoljenja ta izjava izgubi svoj pomen in veljavnost.</p>
<p>DK EU Overensstemmelse certifikat Undertegnede Husqvarna AB, 561 82 Huskvarna, Sweden bekræfter hermed, at enheder listede herunder, ved afsendelse fra fabrikken, er i overensstemmelse med harmoniserede EU retningslinjer, EU sikkerheds standarder og produkt specifikations standarder. Dette certifikat træder ud af kraft hvis enhederne er ændret uden vor godkendelse.</p>	<p>HR Izjava o skladnosti EU-a Dolje potpisana tvrtka Husqvarna AB, 561 82 Huskvarna, Sweden ovime potvrđuje da dolje navedeni uređaji u izvedbi plaširanoj na tržište ispunjavaju zahtjeve harmoniziranih EU smjernica, EU sigurnosnih normi i normi za određene proizvode. Ova izjava postaje ništavna u slučaju izmjene uređaja koje nismo odobrili.</p>
<p>FI EU-yhdenmukaisuusvakuutus Allekirjoittanut Husqvarna AB, 561 82 Huskvarna, Sweden vakuuttaa, että alla mainittu laitteet täyttävät tehtaaltamme lähtiesään yhdenmukaisistettujen EU-direktiivien, EU-turvallisuusstandardien ja tuotekohtaisten standardien vaatimukset. Laitteisiin tehyd muutokset, joista ei ole sovittu kanssamme, joutavat tämän vakuutuksen raukaamiseen.</p>	<p>RO UE-Certificat de conformitate Prin prezenta Husqvarna AB, 561 82 Huskvarna, Sweden, certifica faptul ca, in momentul in care produsele mentionate mai jos ies din fabrica sunt in concordanta cu directivele UE, standardele de siguranta UE si standardele specifice ale produsului UE. Acest certificat devine nul in cazul modificării aparatului fără aprobarea noastră.</p>
<p>I Dichiarazione di conformità alle norme UE La sottoscritta Husqvarna AB, 561 82 Huskvarna, Sweden certifica che il prodotto qui di seguito indicato, nei modelli da noi commercializzati, è conforme alle direttive armonizzate UE nonché agli standard di sicurezza e agli standard specifici di prodotto. Qualunque modifica apportata al prodotto senza nostra specifica autorizzazione invalida la presente dichiarazione.</p>	<p>BG ЕС-Декларация за съответствие Подписаната фирма Husqvarna AB, 561 82 Huskvarna, Sweden декларира, че описаните по-долу уреди, пуснати в продажба съгласно нашата спецификация, изпълняват изискванията на хармонизираните ЕС-директиви, ЕС-стандарти за безопасност и специфични производствени стандарти. При промяна на уреда, която не е съгласувана с нас, тази декларация губи своята валидност.</p>
<p>E Declaración de conformidad de la UE El que suscribe Husqvarna AB, 561 82 Huskvarna, Sweden declara que la presente mercancía, objeto de la presente declaración, cumple con todas las normas de la UE, en lo que a normas técnicas, de homologación y de seguridad se refiere. En caso de realizar cualquier modificación en la presente mercancía sin nuestra previa autorización, esta declaración pierde su validez.</p>	<p>EST Eli vastavusdeklaratsioon Allekirjutanut Husqvarna AB, 561 82 Huskvarna, Sweden kinnitab, et kirjeldatud seade vastab meie poolt riigusse viidud kujul ELi harmoniseeritud direktiividele, ELi ohutusstandarditele ja tootega seotud standarditele. Meiega kooskõlastamata muudatus tegemise korral seadmel kaotab see deklaratsioon kehtivuse.</p>
<p>P Certificado de conformidad da UE Os abaixo mencionados Husqvarna AB, 561 82 Huskvarna, Sweden, por este meio certificam que ao sair da fábrica os aparelhos abaixo mencionados estão de acordo com as direttrizes harmonizadas da UE, padrões de segurança e de produtos específicos. Este certificado ficará nulo se as unidades forem modificadas sem a nossa aprovação.</p>	<p>LT ES Atitikties deklaracija Pasirašanti mūsų Husqvarna AB, 561 82 Huskvarna, Sweden patvirtina, kad žemiau nurodyti prietaisai ir jų modeliai, kurie buvo pagaminti mūsų gamyklose atitinka ES direktyvas, ES saugumo standartus ir specifinius gaminių standartus. Atlikus bet kokį prietaiso pakeitimą, kuris nėra suderintas su mumis, ši deklaracija praranda galiojimą.</p>
<p>PL Deklaracja zgodności Unii Europejskiej Husqvarna AB, 561 82 Huskvarna, Sweden potwierdza, że poniżej określone urządzenia w wersji oferowanej przez nas do sprzedaży spełniają wymagania zharmonizowanych dyrektyw Unii Europejskiej, standardu bezpieczeństwa Unii Europejskiej i standardu specyficznego dla tego typu produktów. W przypadku zmiany urządzenia, która nie została z nami uzgodniona, niniejsza deklaracja traci moc obowiązującą.</p>	<p>LV ES-atbilstības deklarācija Parakstīstusies Husqvarna AB, 561 82 Huskvarna, Sweden, Vācija apstiprina, ka sekojoši apzīmētās iekārtas, kurās mēs izplatām, savā izpildījumā atbilst harmonizētajām ES direktīvām, ES drošības standartiem un produkta specifiskajiem standartiem. Ar mūsu neapstiprinātām izmaiņām iekārtā šī deklarācija zaudē savu derīgumu.</p>

<p>Bezeichnung der Geräte: Description of the units: Désignation du matériel : Omschrijving van de apparaten: Produktbeskrivning: Beskrivelse af produktet: Laitteen nimiys: Descrizione dei prodotti: Descripción de la mercancia: Descrição dos aparelhos: Nazwa urządzenia: A készülékek megnevezése: Označení přístrojů: Označenie zariadenia: Όνομασία της συσκευής: Opis naprave: Oznaka uređaja: Descrierea articolelor: Обозначение на уредите: Seedmete nimetus: Prietaisų pavadinimas: Iekārtu apzīmējums:</p>	<p>Gartenpumpe Garden Pump Pompe de surface pour arrosage Besproeiingspomp Bevatningspomp Трукумпе Puutarhapumppu Pompa da giardino Bomba para jardín Bomba de Jardim Pompa ogrodowa Kerti szivattyú Zahradní čerpadlo Záhradné čerpadlo Αντλία κήπου Vrtna črpalka Vrtna pumpa Pompa de grădină Градинска помпа Aiarump Siop siurblys Dārza sūknis</p>	<p>Schall-Leistungspegel: Noise level: Puissance acoustique : Geluidsniveau: Ljudnivá: Lydtrykksniveau: Melun tehotosa: Livello rumorosità: Nível sonoro: Nível de ruído: Poziom zmerzenia dźwięku: Zajteljesítmény szint: Hluková hladina výkonu: Hluková hladina hluku: Επίπεδο ισχύος ήχου: Nivo hrupa: Razina zvučne snage Nível de putere acustică: Ниво на шума: Helivõimsuse tase: Garso stiprumo lygis: Troksņu jaudas līmenis:</p>	<p>gemessen / garantiert measured / guaranteed mesurée / garantie gemeten / gegarandeerd uppmätt / garanterad afmält / garanti mitattu / taattu testato / garantito medido / garantizado medido / garantido zmierzono / gwarantowane mért / garantált naměřeno / garantováno meraná / garantovaná μετρήθηκαν / εγγυημένα izmerjeno / zagotovljeno izmerjeno / garantirano măsurat / garantat измерено / гарантирано mõõdetud / garanteeritud išmatuotas / garantuotas izmērtais / garantētais</p>				
<p>Typ: Type: Type : Typ: Type: Tyypit: Modello: Tipo: Tipo: Typ:</p>	<p>Típusok: Typ: Typ: Típusok: Tip: Tipov: Típusok: Típus: Típus: Típus: Modelis:</p>	<p>Art.-Nr.: Art. No.: Référéncé : Art.n.r.: Art.n.r.: Art. nr.: Tuoten:o Art. : Art. No: Art. no: Nr artykuła:</p>	<p>Cikkszám: Číslo článku: Art. : Αριθ. ειδους: Art št.: br. art. Nr art.: Apt. номер: Toote nr: Gaminio nr. : Izstr.:</p>	<p>1732 1734 1736</p>	<p>79 dB (A) / 82 dB (A) 77 dB (A) / 80 dB (A) 75 dB (A) / 79 dB (A)</p>	<p>Einbringungsjaahr der CE-Kennzeichnung: Year of CE marking: Année d'apposition du marquage CE : Installatiejaar van de CE-aanduiding: Märkningsår: CE-Mærkningsår: CE-merkin kiinnitysvuosi: Anno di applicazione della certificazione CE: Colocación del distintivo CE: Ano de marcação pela CE: Rok nadania oznakowania CE: CE-jelzés elhelyezésének éve:</p>	<p>Rok umístění značky CE: Rok udelenia značky CE: Έτος σήματος CE: Leto namestitve CE- oznake: Godina dobivanja CE oznake: Anul de marcarea CE: Година на поставяне на CE-маркировка: CE-märgistuse paigaldamise aasta: Metai, kada pažymėta CE-ženkle: CE-marķējuma uzlikšanas gads:</p>
<p>EU-Richtlinien: EU directives: Directives européennes : EU-richtlijnen: EU directiv: EU Retningslinjer: EY-direktiivit: Direttive UE: Normativa UE: Directrices da UE: Dyrektwy Unii Europejskiej: EU-irányelvek: Směrnice EU: EU-Predpisy: Οδηγίες της ΕΕ: ES-smernice:</p>	<p>EU smjernice: Directive UE: EC-директиви: ELI direktiivid: ES direktivos: ES-direktivas:</p>	<p>2006/95/EG (valid to 19.04.2016) 2014/35/EG (valid from 20.04.2016) 2004/108/EG (valid to 19.04.2016) 2014/30/EG (valid from 20.04.2016) 2000/14/EG 2011/65/EG</p>					
<p>Harmonisierte EN:</p>	<p>EN 60335-1 EN 60335-2-41</p>						
<p>Hinterlegte Dokumentation: GARDENA- Technische Dokumentation, M. Kugler 89079 Ulm Deposited Documentation: GARDENA Technical Documentation, M. Kugler 89079 Ulm Documentation déposée: Documentation technique GARDENA, M. Kugler 89079 Ulm</p>	<p>Konformitätsbewertungsverfahren: Nach 2000/14/ EG Art. 14 Anhang V Conformity Assessment Procedure: according to 2000/14/EC Art.14 Annex V Procédure d'évaluation de la conformité: Selon 2000 /14 /CE art. 14 Annexe V</p>						
			<p>Ulm, den 29.06.2015 Ulm, 29.06.2015 Fait à Ulm, le 29.06.2015 Ulm, 29-06-2015 Ulm, 2015.29.06. Ulm, 29.06.2015 Ulmissa, 29.06.2015 Ulm, 29.06.2015 Ulm, 29.06.2015 Ulm, dnja 29.06.2015 Ulm, 29.06.2015 Ulm, 29.06.2015 Ulm, 29.06.2015 Ulm, 29.06.2015 Ulm, 29.06.2015 Ulm, 29.06.2015 Ulm, 29.06.2015 Ulm, 29.06.2015 Ulm, 29.06.2015 Ulm, 29.06.2015 Ulm, 29.06.2015 Ulm, 29.06.2015 Ulm, 29.06.2015 Ulm, 29.06.2015 Ulm, 29.06.2015 Ulm, 29.06.2015 Ulm, 29.06.2015 Ulm, 29.06.2015 Ulm, 29.06.2015</p>	<p>Der Bevollmächtigte Authorised representative Le mandataire De gevolmachtigde Auktoriserad representant Autoriseret repræsentant Valtuutettu edustaja Persona delegata La persona autorizada O representante Pohnomocnik Meghatalmazott Zplnomocněnec Splnomocnený Ο εξουσιοδοτημένος Pooblaščenec Ovlaštena osoba Conducerea tehnică Упълномощен Volitatud esindaja Įgaliotasis atstovas Pilnvarotā persona</p>	<p>2010</p> <p> R. Pompe Vice President</p>		

Pumpen-Kennlinien
Performance characteristics
Courbes de performance
Prestatiegrafiek
Kapacitetskurva
Ydelses karakteristika
Pumpun ominaiskäyrä
Pumpekarakteristikk
Curva di rendimento
Curva caracteristica de la bomba
Características de performance
Charakterystyka pompy
Szivattyú-jelleggörbe
Charakteristika čerpadla
Charakteristiky čerpadla
Χαρητηριστικό διάγραμμα
Кривая производительности насоса
Karakteristika črpalka
Obilježja pumpe
Karakteristika pumpe
Крива характеристики насоса
Caracteristică pompă
Помпа карактер еѓриси
Помпена карактеристика
Fuqia e pompës
Pumba karakteristik
Siurblio charakteristinė kreivė
Տւկղա raksturlիկնե

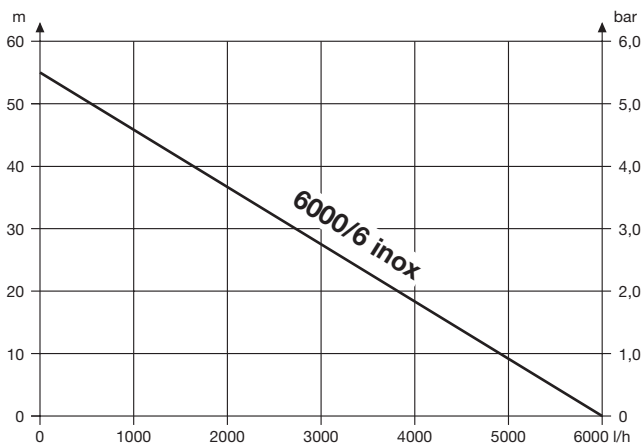
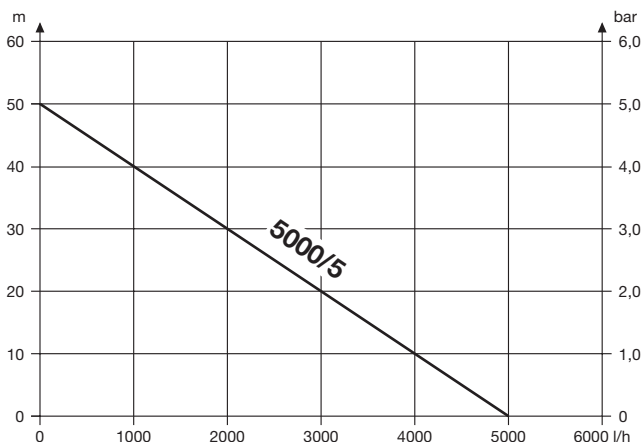
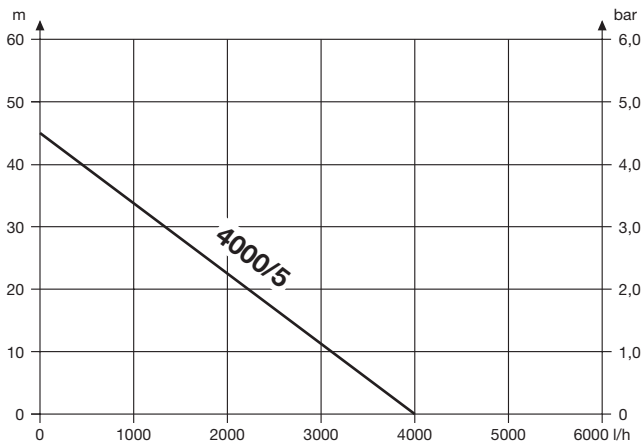

Deutschland / Germany

GARDENA GmbH
Central Service
Hans-Lorenser-Straße 40
D-89079 Ulm
Produktfragen:
(+49) 731 490-123
Reparaturen:
(+49) 731 490-290
service@gardena.com

Albania

COBALT Sh.p.k.
Rr. Siri Kodra
1000 Tirana
Argentina
Husqvarna Argentina S.A.
Av.del Libertador 5954 –
Piso 11 – Torre B
(C1428ARP) Buenos Aires
Phone: (+54) 11 5194 5000
info.gardena@
ar.husqvarna.com

Armenia

Garden Land Ltd.
61 Tigran Mets
0005 Yerevan

Australia

Husqvarna Australia Pty. Ltd.
Locked Bag 5
Central Coast BC
NSW 2252
Phone: (+61) (0) 2 4352 7400
customer.service@
husqvarna.com.au

Austria / Österreich

Husqvarna Austria GmbH
Industriezeile 36
4010 Linz
Tel.: (+43) 732 7701 01-485
service.gardena@
husqvarnagroup.com

Azerbaijan

Firm Progress
a. Aliyev Str. 26A
1052 Baku

Belgium

GARDENA Belgium NV/SA
Sterebeekstraat 163
1930 Zaventem
Phone: (+32) 2 720 92 12
Mail: info@gardena.be

Bosnia / Herzegovina

SILK TRADE d.o.o.
Industrijska zona Bukva bb
74260 Tešanj

Brazil

Husqvarna do Brasil Ltda
Av. Francisco Matarazzo,
1400 – 19º andar
São Paulo – SP
CEP: 05001-903
Tel: 0800-112252
marketing.br.husqvarna@
husqvarna.com.br

Bulgaria

Хускварна България ЕООД
Бул. „Андрей Липчев“ № 72
1799 София
Тел.: (+359) 02/9753076
www.husqvarna.bg

Canada / USA

GARDENA Canada Ltd.
100 Summerlea Road
Brampton, Ontario L6T 4X3
Phone: (+1) 905 792 9330
info@gardena.canada.com

Chile

Maquinarias Agroforestales
Ltda. (Maga Ltda.)
Santiago, Chile
Avda. Chesterton
8355 comuna Las Condes
Phone: (+56) 2 202 4417
Dalton@мага.cl
Zipcode: 7560330
Temuco, Chile
Avda. Valparaiso # 01466
Phone: (+56) 45 222 126
Zipcode: 4780441

China

Husqvarna (China) Machinery
Manufacturing Co., Ltd.
No. 1355, Jia Xin Rd.,
Ma Lu Zhen, Jia Ding Dist.,
Shanghai
201801
Phone: (+86) 21 59159629
Domestic Sales
www.gardena.com.cn

Colombia

Husqvarna Colombia S.A.
Calle 18 No. 88 D-31, zona
Industrial de Montevideo
Bogotá, Cundinamarca
Tel. 571 2922700 ext. 105
jairo.salazar@
husqvarna.com.co

Costa Rica

Europa Comex
Euroiberoamericana S.A.
Los Colegios, Moravia,
200 metros al Sur del Colegio
Saint Francis – San José
Phone: (+506) 297 68 83
exim_euro@racsa.co.cr

Croatia

SILK ADRIA d.o.o.
Josipa Lončara 3
10090 Zagreb
Phone: (+385) 1 3794 580
silk.adria@zg.t-com.hr

Cyprus

Med Marketing
17 Digeni Akrita Ave
P.O. Box 27017
1641 Nicosia

Czech Republic

Husqvarna Česko s.r.o.
Türkova 2319/5b
149 00 Praha 4 – Chodov
Bezplatná infolinka:
800 100 425
servis@cz.husqvarna.com

Denmark

GARDENA / Husqvarna
Consumer Outdoor Products
Salgsafdelning Danmark
Box 9003
S-200 39 Malmö
info@gardena.dk

Dominican Republic

BOSQUESA, S.R.L
Carretera Santiago Licey
Km. 5 ½
Esquina Copal II,
Santiago
Dominican Republic
Phone: (+809) 736-0333
joserbosquesa@claro.net.do

Ecuador

Husqvarna Ecuador S.A.
Arupos E1-181 y 10 de
Agosto Quito, Pichincha
Tel. (+593) 22800739
francisco.jacom@
husqvarna.com.ec

Estonia

Husqvarna Eesti OÜ
Consumer Outdoor Products
Kesk tee 10, Aaviku küla
Rae vald
Harju maakond
75305 Estonia
kontakt.etj@husqvarna.ee

Finland

Oy Husqvarna Ab
Consumer Outdoor Products
Lauttarhankatu 8 B / PL 3
00581 HELSINKI
info@gardena.fi

France

Husqvarna France
9/11 Allée des pierres mayettes
92635 Gennevilliers Cedex
France
http://www.gardena.com/fr
N° AZUR: 0 810 00 78 23
(Prix d'un appel local)

Georgia

ALD Group
Belashvili 8
1159 Tleilisi

Great Britain

Husqvarna UK Ltd
Preston Road
Aycliffe Industrial Park
Newton Aycliffe
County Durham
DL5 6UP
info.gardena@
husqvarna.co.uk

Greece

Π. ΠΑΠΑΔΟΠΟΥΛΟΣ ΑΕΒΕ
Λεωφ. Αθηνών 92
Αθήνα
Τ.Κ.104 42
Ελλάδα
Τηλ. (+30) 210 5193100
info@papadopoulos.com.gr

Hungary

Husqvarna Magyarországt Kft.
Ezred u. 1-3
1044 Budapest
Telefon: (+36) 1 251-4161
vevoszolgalat.husqvarna@
husqvarna.hu

Iceland

Ó. Johnson & Kaaber
Tunguhsalsi 1
110 Reykjavik
ojoj@oik.is

Ireland

Husqvarna UK Ltd
Preston Road
Aycliffe Industrial Park
Newton Aycliffe
County Durham
DL5 6UP
info.gardena@
husqvarna.co.uk

Italy

Husqvarna Italia S.p.A.
Via Como 72
23868 VALMADRERA (LC)
Phone: (+39) 0341.203.111
info@gardenaitalia.it

Japan

KAKUICHI Co. Ltd.
Sumitomo Realty &
Development Kojimachi
BLDG., 8F
5-1 Nibanncyo
Chiyoda-ku
Tokyo 102-0084
Phone: (+81) 33 264 4721
m_ishihara@kaku-ichi.co.jp

Kazakhstan

LAMED Ltd.
155/1, Tazhibayevoi Str.
050060 Almaty
IP Schmidt
Abayavenue 3B
110 005 Kostanay

Korea

Kyung Jin Trading Co., LTD.
107-4, SunDuk Bld.,
YangJae-dong,
Seocho-gu,
Seoul, (zipcode: 137-891)
Phone: (+82) (0)2 574-6300

Kyrgyzstan

Alye Maki
av. Moladaya Guardir J 3
720014
Bishkek

Latvia

Husqvarna Latvija
Consumer Outdoor Products
Bākuži iela 6
LV-11024 Riga
lithu@husqvarna.lv

Lithuania

LITHUANIA Lietuva
Consumer Outdoor Products
Atleities pl. 77 C
LT-52104 Kaunas
centras@husqvarna.lt

Luxembourg

Magasins Jules Neuberg
33, rue Jacques Stas
Luxembourg-Gasperich 2549
Case Postale No. 12
Luxembourg 2010
Phone: (+352) 40 14 01
api@neuberg.lu

Mexico

AFOSA
Av. Lopez Mateos Sur # 5019
Col. La Calma 45070
Zapopan, Jalisco
Mexico
Phone: (+52) 33 3818-3434
icornejo@afosa.com.mx

Moldova

Comvel S.R.L.
290A Muncesti Str.
2002 Chisinau

Netherlands

GARDENA Nederland B.V.
Postbus 50176
1305 AD ALMERE
Phone: (+31) 36 521 00 00
info@gardena.nl

Neth. Antilles

Jonka Enterprises N.V.
Sta. Stoa Weg 196
P.O. Box 8200
Curaçao
Phone: (+599) 9 767 66 55
pjm@jonka.com

New Zealand

Husqvarna New Zealand Ltd.
PO Box 76-437
Manukau City 2241
Phone: (+64) (0) 9 9202410
support.nz@husqvarna.co.nz

Norway

GARDENA
Husqvarna Consumer
Outdoor Products
Salgskontor Norge
Klevereveien 6
1540 Vestby
info@gardena.no

Peru

Husqvarna Perú S.A.
Jr. Ramón Cárcamo 710
Lima 1
Tel: (+51) 1 3320400 ext. 416
javier.remuzgo@
husqvarna.com

Poland

Husqvarna
Poland Spółka z o.o.
ul. Wysockiego 15 b
03-371 Warszawa
Phone: (+48) 22 330 96 00
gardena@husqvarna.com.pl

Portugal

Husqvarna Portugal, SA
Lagoa - Albarraque
2635 - 595 Rio de Mouro
Tel.: (+351) 21 922 85 30
Fax: (+351) 21 922 85 36
info@gardena.pt

Romania

Madex International Srl
Sosseua Odaii 117-123,
RO 013603 Bucuresti, S1
Phone: (+40) 21 352.76.03
madex@mes.ro

Russia / Россия

ООО „Хускварна“
141400, Московская обл.,
г. Химки,
улица Ленинградская,
владение 39, стр.6.
Бизнес Центр
„Химки Бизнес Парк“,
помещение 0802.04,
http://www.gardena.ru

Serbia

Domel d.o.o.
Autoput za Novi Sad bb
11273 Belgrade
Phone: (+381) 118 488 88 12
miroslav.vejina@domel.rs

Singapore

Hy-Ray PRIVATE LIMITED
40 Jaleh Pemimpin
#02-08 Tat Ann Building
Singapore 577185
Phone: (+65) 6253 2277
shying@hyray.com.sg

Slovak Republic

Husqvarna Cesko s.r.o.
Türkova 2319/5b
149 00 Praha 4 – Chodov
Bezplatná infolinka:
800 154 044
servis@sk.husqvarna.com

Slovenia

Husqvarna Austria GmbH
Industriezeile 36
4010 Linz
Tel.: (+43) 732 77 01 01-485
service.gardena@
husqvarnagroup.com

South Africa

Husqvarna
Husqvarna (Pty) Ltd
Postnet Suite 250
Private Bag X6,
Cascades, 3202
South Africa
Phone: (+27) 33 846 9700
info@gardena.co.za

Spain

Husqvarna España S.A.
C/ Basauri, nº 6
La Florida
28023 Madrid
Phone: (+34) 91 708 05 00
atencioncliente@gardena.es

Suriname

Agrofix n.v.
Verlengde Hogestraat # 22
Phone: (+597) 472426
agrofix@sr.net
Pobox : 2006
Paramaribo
Suriname – South America

Sweden

Husqvarna AB
S-561 82 Huskvarna
info@gardena.se

Switzerland / Schweiz

Husqvarna Schweiz AG
Consumer Products
Industriestrasse 10
5506 Mägenwil
Phone: (+41) (0) 62 887 37 90
info@gardena.ch

Turkey

GARDENA Dost Diş Ticaret
Müesseslik A.Ş.
Sanayi Cad. Adil Sokak
No: 1/B Kartal
34873 Istanbul
Phone: (+90) 216 38 93 939
info@gardena-dost.com.tr

Ukraine / Україна

ТОВ „Хусварна Україна“
вул. Васильківська, 34,
офіс 204-г
03022, Київ
Тел. (+380) 44 998 39 20
info@gardena.ua

Uruguay

FELI SA
Entre Ríos 1083 CP 11800
Montevideo – Uruguay
Tel: (+598) 22 03 18 44
info@felisa.com.uy

Venezuela

Corporación Casa y Jardín C.A.
Av. Caroní, Edif. Trezmen, PB.
Colinas de Bello Monte,
1050 Caracas.
Tlf: (+58) 212 992 33 22
info@casayjardin.net.ve

1732-20.960.07/0715

© GARDENA
Manufacturing GmbH
D-89079 Ulm
http://www.gardena.com