

MultiControl duo
Art. 1874

GB Operating Instructions

Water Computer

FIN Käyttöohje

Kastelunohjain

S Bruksanvisning

Bevattningscomputer

DK Brugsanvisning

Vandingscomputer

N Bruksanvisning

Vanningscomputer

EST Kasutusjuhend

Kastmiskompuuter

LV Lietošanas instrukcija

Laistīšanas dators

LT Naudojimo instrukcija

Laistymo kompiuteris

D Betriebsanleitung

Bewässerungscomputer

GARDENA Water Computer MultiControl duo



Translation of the original instructions from German.

Please read these operating instructions carefully and observe the information they contain. Use these operating instructions to familiarise yourself with the product, the proper use and the safety instructions.



For safety reasons, children and young people under the age of 16, as well as people not familiar with these operating instructions, should not use this product. Persons with reduced physical or mental abilities may use the product only if they are supervised or instructed by a responsible person. Children must be supervised to ensure that they do not play with the product. Never operate the product when you are tired, ill or under the influence of alcohol, drugs or medicine.

→ Please keep these operating instructions in a safe place.

Contents

- 1. Where to Use Your GARDENA Water Computer 2
- 2. Safety Instructions 2
- 3. Function 3
- 4. Initial Operation 5
- 5. Programming 7
- 6. Storage 11
- 7. Maintenance 12
- 8. Troubleshooting 12
- 9. Available Accessories 13
- 10. Technical Data 13
- 11. Service / Warranty 14

1. Where to Use Your GARDENA Water Computer

Intended use:

The GARDENA Water Computer is intended for private use in domestic and hobby gardens, exclusively for outdoor use, to control sprinklers and watering systems. The Water Computer has two separate outlets and can be used e.g. for automatic irrigation during your holiday.

Please note:



The GARDENA Water Computer must not be used for industrial purposes or in conjunction with chemicals, foodstuffs, easily flammable and explosive materials.

2. Safety Instructions

Battery:

To ensure the Water Computer runs safely, only a 9V alkaline manganese battery (alkaline) type IEC 6LR61 must be used.

In order to stop the Water Computer from failing because of a weak battery if you are away for a long time, the battery must be replaced when the battery display still shows only 1 bar.

Setting up

Warning!

The Water Computer must not be used indoors.

→ Only use the Water Computer outdoors.

The Water Computer may only be set up vertically with the sleeve nut to the top to prevent water penetrating into the battery compartment.

The minimum water output to ensure correct functioning of the Water Computer is 20 - 30 l/h per outlet. E.g. for controlling the Micro-Drip System, at least 10 pieces 2-litre Drip Heads are required.

At high temperatures (over 60 °C at the display) the LCD display may extinguish. This does not affect the program in any way. When the computer cools down the LCD display illuminates again.

The max. temperature for the water flow is 40 °C.

→ Only use clear fresh water.

The minimum operating pressure is 0.5 bar, the maximum operating pressure is 12 bar.

Avoid tensile strain.

→ Do not pull the hose connected to the Water Computer.

Programming

→ Program the Water Computer with the tap turned off.

In this way, you can prevent unintentional water penetration.

You can remove the control unit from the housing to program the Water Computer.

If the controller is removed when the valve is open, the valve remains open until the controller is fitted again.

3. Function

With the Water Computer, the garden can be watered fully automatically up to 3 times a day (every 8 hours) via both outlets. Sprinklers, a sprinkler system or a drip head watering system can be used for watering.

The Water Computer carries out watering fully automatically according to the set program and can therefore also be used during holidays. Early in the morning or late in the evening, evaporation and therefore water consumption is lowest.

Controls:

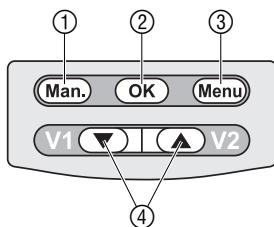

The watering programme is easily entered using the controls.

Control

- ① **Man. button**
- ② **OK-Taste**
- ③ **Menu button**
- ④ **▼-▲ buttons (V1/V2)**

Function

- For switching the water throughput on or off manually.
- Applies the values set with the ▼-▲ buttons.
- Changes to the next programme level.
- Change the adjustable values in each level/selection of outlet (V1/V2) in Level 1.

Display levels:

The 6 display levels can be selected one after the other by pressing the **Menu** key.

- Level 1: **Normal display**
- Level 2: **Current time and day of the week**
- Level 3: **Watering start time**
- Level 4: **Watering duration**
- Level 5: **Watering frequency**
- Level 6: **Switch programme on or off / Deactivate sensor**

The display level can be changed at any time by pressing the **Menu** button. All programme data changed up to this time and confirmed with the **OK** button is saved. If data is changed during programmed irrigation and confirmed with the **OK** button then the valve is closed.

Display messages:

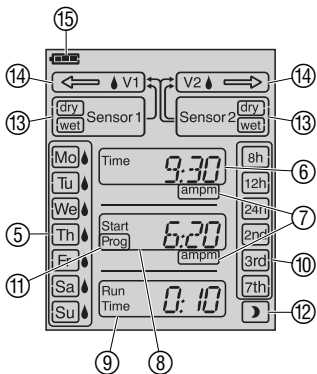

Display	Description
⑤ Weekdays Mo, Tu, ...	Current weekday <input type="checkbox"/> or programmed watering days ☀.
⑥ Time	Current time of day (flashes when in input mode).
⑦ am / pm	Display for 12-hour clock (e.g. in USA, Canada).
⑧ Start	Watering start time (flashes when in input mode).
⑨ Run Time	Watering duration (flashes when in input mode).
⑩ 8h, 12h, 24h, 2nd, 3rd, 7th	Watering cycle (with <input type="checkbox"/> activated). Every 8 / 12 / 24 hours; every 2nd / 3rd / 7th day.
⑪ Prog ON / OFF	Watering programme on (ON) / off (OFF).
⑫ Direct sensor control	Watering is automatically controlled between 20:00 and 06:00 via the Soil Moisture Sensor.
⑬ Sensor 1 / 2 dry / wet	Dry sensor dry : watering is carried out. Wet sensor wet : watering is not carried out.
⑭ Valve ← V1 / Valve V2 →	The arrow indicates the selected valve: - displayed ☀: the valve is connected - flashing ☀: the valve is open
⑮ Battery	Indicates 5 battery levels: 3 bars: Battery fully charged 2 bars: Battery half full 1 bar: Battery low 0 bar: Battery almost flat Frame is flashing: Battery flat

If the battery frame is flashing, the valve is no longer opened. **A valve opened by the programme will also close again if the battery is flat.** The battery display is reset when the battery is changed.

2 Bars	1 Bar	0 Bar flashing	Frame is flashing
Battery half full	Battery low	Battery almost flat	Battery flat
Valve opens.	Valve opens.	Valve still opens.	Valve does not open.
The Water Computer is guaranteed to work for a minimum of 4 more weeks.	The Water Computer will continue to work for no more than 4 weeks.	The Water Computer stops working soon.	The Water Computer stops working.
	It is advisable to change the battery.	The battery must be changed soon.	The battery must be changed.
	→ Replace battery (see 4. Initial Operation "Inserting battery").		

4. Initial Operation

Insert battery:

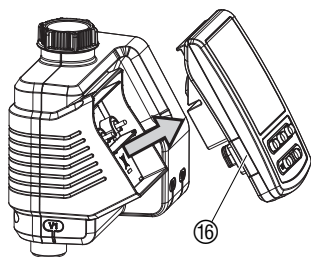

The Water Computer must only be operated with a 9 V alkali-manganese (alkaline) battery type IEC 6LR61.

1. Remove controller ⑯ from the housing of the Water Computer.
2. Insert battery in the battery compartment ⑰. **Observe correct polarity P.** *The display shows all the LCD-symbols for 2 seconds and then moves to the time/day of week level.*
3. Install controller ⑯ on the housing again.

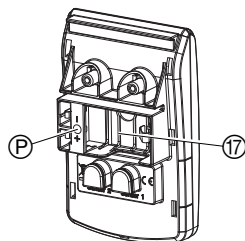

Set display to 24-hours or 12-hours (am/pm):

The factory setting is the 24-hour display.

→ Press the **Man.** button continuously while inserting the battery.

Connect soil moisture or rain sensor (optional):

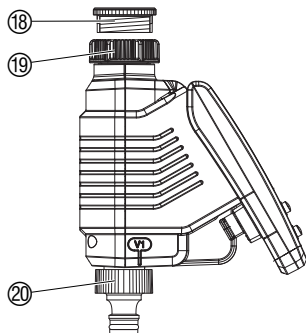

The Water Computer is fitted with a sleeve nut ⑱ for taps with (G 1") (33.3 mm) thread. The adaptor supplied ⑱ allows the Water Computer to be connected to taps with a (G 3/4") thread (26.5 mm).

1. **For tap with a G 3/4" (26.5 mm) thread:**
Screw adaptor ⑱ on to the tap manually (do not use pliers).
2. Screw sleeve nut ⑱ of the Water Computer on to the adaptor thread by hand (do not use pliers).
3. Screw Tap Connectors ⑳ onto the two Water Computer outlets.

Connect Soil Moisture Sensor or Rain Sensor (optional):

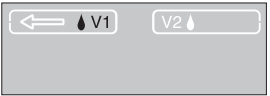
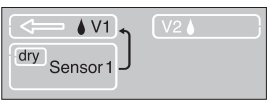
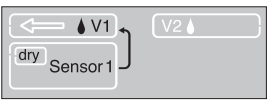
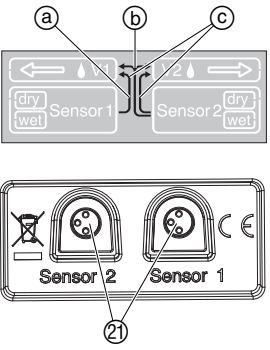

In the case of rain, or when the soil is sufficiently moist, a programmed, automatic watering programme will be stopped or prevented from starting. Manual operation is possible at all times.

Sensor assignment:

- a) A sensor in Connector 1 : Sensor only applies to Valve 1
- b) A sensor in Connector 2 : Sensor applies to both valves
- c) Sensor in Connectors 1 and 2 : Sensor 1 applies to Valve 1, Sensor 2 applies to Valve 2

1. Place Soil Moisture Sensor in watered area – or – place Rain Sensor **outside** of the watered area.
2. Remove controller (16) from the housing of the Water Computer.
3. If necessary, connect sensor to Extension Cable or Adaptor at the sensor connection (21) of the Water Computer.

Activate sensor:

A sensor will be automatically activated after 60 sec. The sensor assignment (a), (b) or (c) (arrow) and the current sensor status **dry / wet** will be displayed.
E.g. Sensor 1 **dry** (dry) Valve 1 (a) only.

Deactivate sensor [Level 6]:

If watering is to be without a sensor, although a sensor was previously activated, then this sensor must be deactivated.

1. Remove sensor from Water Computer.
2. Press **Menu** button 5 times [Level 6].
*The sensor assignment (a), (b) or (c) (arrow) and the current sensor status **dry / wet** will be displayed.*
3. Press **OK** button.
The sensor has been deactivated.

To connect older sensors (with 2-pin connector), the **GARDENA Adapter Cable 1189-00.600.45** is required, which can be procured from GARDENA Service.

Fit anti-theft device (optional):

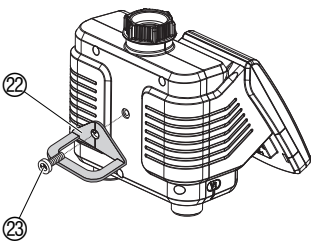

To secure your Water Computer against theft, you can obtain the **GARDENA Anti-theft device Art. No. 1815-00.791.00** from GARDENA Service.

1. Screw clamp (22) with screw (23) firmly to the back of the Water Computer.
2. Use clamp (22) e.g. for fixing a chain.

It is no longer possible to remove the screw after it has been screwed in.

5. Programming

Set current time and day of week:

[Level 2]

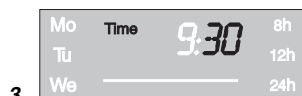

To set the programme, the controller can be removed and mobile programming can be carried out (see 4. Initial Operation “Inserting battery”).

Programming can be discontinued at any time by pressing the **Man.** button. All programme data changed up to this time and confirmed with the **OK** button is saved.

1. Press **Menu**-key [Level 2] (not necessary if the battery has just been inserted).
The hours display and Time flash.
2. Set the time in hours with the **▼-▲** button (example: **9** hours) and confirm with the **OK**-key.
Time and the minutes display flash.
3. Set the time in minutes with the **▼-▲** button (example: **30** minutes) and confirm with the **OK**-key.
Time and the day of the week display flash.
4. Set day of week with the **▼-▲** buttons (e.g. **(Tu)**) and confirm with the **OK** button.
The display moves to the message “Entering watering programme” of the watering mode “Scheduled watering” [Level 3].
Start Prog and the hours will flash on the display.

Watering modes:

The Water Computer has 3 watering modes:

A) Scheduled watering:

With the “scheduled watering”, watering begins as per the set programme. There is the additional option to consider soil moisture or rain in the watering programme. In the case of rain or sufficiently moist soil, the programme’s stop is activated or activation of the programme is prevented. Manual watering **Man. + OK** is still possible.

B) Direct sensor control):

With “direct sensor control”, watering is exclusively controlled in dependency on soil moisture between 20:00 and 06:00, if the sensor has indicated **dry**. 1 or 2 Soil Moisture Sensors can be connected.

C) Manual watering:

With “Manual watering”, watering begins immediately after **Man. + OK** has been pressed and can be operated independently of the sensor status.

Entering watering programme:

[Level 3]



[Level 4]

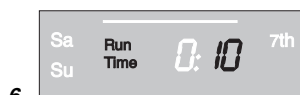

[Level 5]

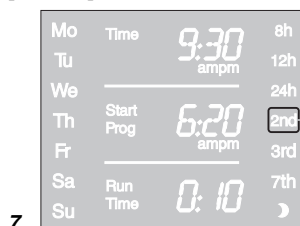

A) Scheduled watering:

- Select programme for Valve 1 (\leftarrow V1) or Valve 2 (V2 \rightarrow) with the ∇ - \blacktriangle buttons (V1/V2), (not possible if the current time of day and weekday have been previously entered).
- Press **Menu**-key twice [Level 3] (not necessary if the current time and day of the week has been entered).
Start Prog and the hours section flash on the display.
- Set the watering start time hours with the ∇ - \blacktriangle button (E.g. 6) and confirm with the **OK**-key.
Start Prog and the minute display flashes on the screen.
- Set the minutes for starting the watering time with the ∇ - \blacktriangle button (example: 20 minutes) and confirm with the **OK**-key.
Run Time and the hours for the watering time flash on the display.
- Set the hours for the watering time with the ∇ - \blacktriangle button (example: 0 hours) and confirm with the **OK**-key.
Run Time and minutes for the watering time flash on the display.
- Set watering time minutes with the ∇ - \blacktriangle button (example: 10 minutes) and confirm with the **OK**-key.
Watering cycle flashes on the display.

The watering frequency can be selected by:

- the (7.) watering cycle (right hand column of the display) – or –
- the (8.) watering days (left hand column of the display).

- Select **watering cycle** with the ∇ - \blacktriangle button (E.g. 2nd) and confirm by pressing **OK**.

8h / 12h / 24 h: Watering every 8 / 12 / 24 hours
2nd / 3rd / 7th: Watering every 2nd / 3rd / 7th day

The display jumps to the watering programme on the screen.

– or –

- Select each watering day with the ∇ - \blacktriangle button (E.g. Mo , Fr Monday and Friday) and confirm by pressing **OK**. Press the **Menu** button.

Display moves to the message "Activate /deactivate watering programme" [Level 6].

If the following day is not a watering day, then watering only takes place until 0:00.

(Ex. watering days = Monday, Tuesday, Friday; Start time = 23:00; Water duration = 2h.

On Monday, watering takes place from 23:00 until Tuesday 01:00.
On Tuesday and Friday, watering takes place from 23:00 until 0:00.)

Activate /deactivate watering programme:

[Level 6]

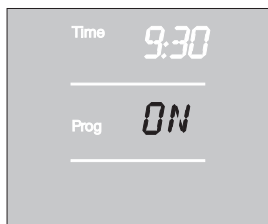

The **Prog ON** must be selected so that the watering programme can start. With **Prog OFF** automatic watering is deactivated. **Prog ON/OFF** can be independently selected for each valve. Also with **Prog OFF** manual watering is possible.

1. Select Valve 1 (↔ **V1**) or Valve 2 (**V2** ↔) with the ▼-▲ button (**V1/V2**) (if a programme was previously created then the valve cannot be selected, the corresponding valve is automatically selected).
2. Press **Menu** button 5 times [Level 6] (not necessary if a programme was previously created).
3. Select **Prog ON** or **Prog OFF** with the ▼-▲ buttons and confirm with the **OK** button.

*For 2 sec. **Prog OK** is shown and then the display moves to the **Normal Display** [Level 1].*

Prog ON: The water computer has now been programmed, i.e. the inbuilt valve opens and closes completely automatically and thus waters at the programmed time.

B) Direct sensor control ☾ :

Prerequisite : at least one GARDENA Soil Moisture Sensor is connected (see 4. Initial Operation). Watering nights (20:00 – 06:00), if the sensor registers dry.

A previously set scheduled watering programme is stored but not carried out.

1. Select programme for Valve 1 (↔ **V1**) or Valve 2 (**V2** ↔) with the ▼-▲ buttons (**V1/V2**).

2. Press **Menu** button 3 times.

Run Time and the watering duration flash on the display.

3. Set watering duration hours with the ▼-▲ buttons (e.g. **0** hours) and confirm with the **OK** button.

Run Time and the watering duration minutes flash on the display.

4. Set watering duration minutes with the ▼-▲ buttons (e.g. **10** minutes) and confirm with the **OK** button.

Watering cycle flashes on the display.

5. Select direct sensor control ☾ with the ▼-▲ buttons and confirm with the **OK** button.

After each watering, a 2-hour watering pause is triggered in order for the Soil Moisture Sensor to record the soil moisture.

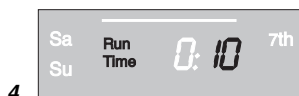
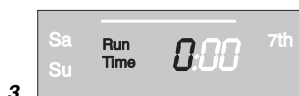

Example :

Watering duration = 10 minutes

Watering begins when the sensor registers dry (Sensor **dry**) between 20:00 and 06:00, and ends when the sensor registers wet (Sensor **wet**) or after 10 minutes at the latest.

2 hours after the end of watering, if dry is registered (Sensor **dry**), watering is again initiated and with wet (Sensor **wet**) there is no further watering etc. for 2 hours up to max. 06:00. There is no watering between 06:00 and 20:00.

The watering duration is preset at the factory to 30 minutes.

Emergency programme (the moon ☾): flashes): If no sensor is inserted in the direct sensor control, or the connection cable is faulty, watering will take place every 24 hours. The watering duration depends on the set run time but is limited to a maximum of 30 minutes.

**Exit direct sensor control
[Level 5]:**

1. Press **Menu** button 4 times.
The moon ☾ flashes on the display.
2. Select a different **watering cycle** with the **▼-▲** buttons and confirm with the **OK** button.

**Read / modify watering
programmes:**

If a value in a programme is to be changed, this can be done without changing the other values in the programme.

1. Press the **Menu** key twice.
Start and the hours flash on the display.
2. Press the **Menu** button to jump to the next programme level
– or –
Change programme data with the **▼-▲** buttons and confirm with the **OK** button.

When the watering duration is changed while a program is running, the current watering cycle is ended.

C) Manual watering:

Each valve can be **opened or closed manually at any time**. A program-controlled open valve can also be closed early without changing the program data (watering start time, watering duration and watering frequency). The controller must be fitted.

1. Select Valve 1 (↔ **V1**) or Valve 2 (**V2** ↔) with the **▼-▲** buttons.
2. Press **Man.**-key to open the valve manually (or to close an open valve).

Run Time and the watering time in minutes (set to **30** minutes in the works) flash for 10 seconds on the display.





3.

3. Whilst the watering time in minutes is flashing, the watering duration can be modified with the ▼-▲ button (between **0:00** and **0:59**) (example: **10** minutes) and confirm with the **OK**-key.

4. Press **Man.**-key to close the valve early.
The valve is closed.

The amended manual opening period is stored, i.e. each time the valve is opened manually in future the modified opening period is preset. If the manual opening period is amended to **0:00**, the valve is closed and also remains closed after the **Man.**-key is pressed (child lock).

If the valve has been manually opened and a programmed start of watering overlaps with the manual opening duration then the watering programme will not be carried out.

Example:

The valve is **opened at 9.00 a.m. manually**, the opening period is 10 minutes. A program with a **start time between 9.00 and 9.10 a.m.** will not be undertaken in this case.

Reset:

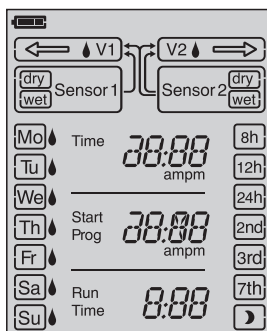

The factory settings are restored.

→ Press **Man.**-key and **Menu**-key simultaneously for 3 seconds.

All the LCD symbols are displayed for 2 seconds and the display moves to the normal display.

- All the program data are set to zero.
- The manual watering period is set to **0:30** again.
- The time and day of the week are retained.

Important information:

If no entry is made during programming for a period of more than 60 seconds, the normal display reappears. In this case all changes made up till now will be applied.

If a sensor inserted in the Water Computer registers wet (**wet**), the corresponding programme will not be carried out.

6. Storage

Storage / Overwintering:



1. To preserve the battery, it should be removed (see 4. Initial Operation).

The programmes remain stored. If the battery is inserted again in spring, only the time of day and the weekday must be newly entered.

2. Store controller and valve unit in a dry place where they are protected from frost.

Disposal:

(in accordance with
Directive 2012/19/EU)



The product must not be added to normal household waste. It must be disposed of in line with local environmental regulations.

→ Important: Make sure that the unit is disposed of via your municipal recycling collection centre.

Disposing of flat batteries:

→ Please return flat batteries to a GARDENA dealer or dispose of them properly at your nearest recycling centre.

Only dispose of batteries when they are **flat**.

7. Maintenance

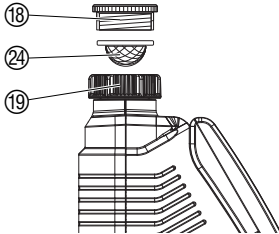
Clean filter:

The filter 24 should be checked regularly and cleaned when necessary.

1. Unscrew sleeve nut 19 of the Water Computer by hand from the tap thread (do not use pliers).
2. If necessary unscrew the adaptor 18.
3. Remove filter 24 from sleeve nut 19 and clean.
4. Fit the Water Computer again (see 4. Putting Your Water Computer into Operation "Connecting Water Computer").

8. Troubleshooting

Fault	Possible Cause	Remedy
No display appears	Battery inserted incorrectly.	→ Check polarity markings match (+/-).
	Flat battery.	→ Insert new alkaline battery.
	Temperature on the display is higher than 60 °C.	Display appears after temperature has dropped.
Manual watering is not possible using the Man. button	Battery flat (frame is flashing).	→ Insert new alkaline battery.
	Manual watering period is set to 0:00 .	→ Set manual watering period to a figure greater than 0:00 (see 5. Programming).
	Tap turned off.	→ Turn tap on.
Watering program is not carried out out (no watering)	Watering program has not been entered completely.	→ Read off watering program and modify if necessary.
	Programs deactivated (Prog. OFF).	→ Activate program (Prog. ON).
	Program entry/modification during or just before the start pulse.	→ Make program entry/modification outside the programmed start times.
	Valve was opened manually previously.	→ Avoid possible program overlaps.
	Tap turned off.	→ Turn tap on.
	Soil moisture or rain sensor registers damp (wet).	→ If dry, check setting/location of soil moisture/rain sensor.

Fault	Possible Cause	Remedy
Watering program is not carried out (no watering)	Battery flat (frame is flashing). Controller is not connected (no display with V1/V2).	→ Insert new alkaline battery. → Mount controller on housing.
Water Computer does not close	Minimum quantity of water drawn is less than 20 l/h.	→ Connect more drip heads.
Symbol direct sensor control is flashing 	Sensor is not correctly connected or not registered.	→ Check Connection Cable and sensor, or activate sensor.
Sensor 1 and/or Sensor 2 is flashing	Sensor is defective.	→ Check Connection Cable and sensor or deactivate sensor.



In the event of other faults please contact GARDENA Service.
Repairs should only be carried out by GARDENA service centres or dealers authorised by GARDENA.

9. Available accessories

GARDENA Soil Moisture Sensor		Art. No. 1188
GARDENA Rain Sensor electronic		Art. No. 1189
GARDENA Anti-theft device		Art. No. 1815-00.791.00 From GARDENA Service
GARDENA Adapter cable	To connect older GARDENA sensors	Art. No. 1189-00.600.45
GARDENA Cable Adapter	For simultaneous connection of Rain- and Soil Moisture Sensor	From GARDENA Service

10. Technical Data

Number of controlled valves:	2
Min./max. operating pressure:	0.5 bar / 12 bar
Flow medium:	Clear fresh water
Max. liquid temperature:	40 °C
Temperature area:	5 °C to 60 °C
Number of program-controlled watering cycles per valve and day:	3 x (every 8 hrs.), 2 x (every 12 hrs.), 1 x (every 24 hrs.)
Number of program-controlled watering cycles per valve and week:	Every day, every 2, 3 or 7 days; or individual selection of weekdays
Watering duration:	1 min. to 3 hours 59 min.
Battery required:	1 x 9V alkaline manganese alkaline battery type IEC 6LR61
Operating time of the battery:	approx. 1 year

11. Service / Warranty

GARDENA guarantees this product for 2 years (from date of purchase). This guarantee covers all serious defects of the unit that can be proved to be material or manufacturing faults.

Under warranty we will either replace the unit or repair it free of charge if the following conditions apply:

- The unit must have been handled properly and in keeping with the requirements of the operating instructions.
- Neither the purchaser or a non-authorised third party have attempted to repair the unit.
- Faults which occur as a result of incorrectly installed or leaking batteries are not covered by the guarantee.
- Damage caused by frost is not covered by the warranty.

This manufacturer's guarantee does not affect the user's existing warranty claims against the dealer/seller.

If you have any problems with your Water Computer, please contact our Customer Service or return the defective unit together with a short description of the problem directly to one of the GARDENA Service Centres listed on the back of this leaflet.

GB Product Liability

We expressly point out that, in accordance with the product liability law, we are not liable for any damage caused by our units if it is due to improper repair or if parts exchanged are not original GARDENA parts or parts approved by us, and, if the repairs were not carried out by a GARDENA Service Centre or an authorised specialist. The same applies to spare parts and accessories.

FIN Tuotevastuu

Korostamme nimenomaan, että tuotevastuulain nojalla emme ole vastuussa laitteistamme johtuneista vahingoista, mikäli nämä ovat aiheutuneet epäasianmukaisesta korjauksesta tai osia vaihdettaessa ei ole käytetty alkuperäisiä GARDENA- varaosia tai hyväksymiämme osia ja korjauksen on suorittanut muu kuin GARDENA -huoltokeskus tai valtuuttamamme ammattihenkilö. Tämä pätee myös lisäosiin ja lisävarusteisiin.

S Produktansvar

Tillverkaren är inte ansvarig för skada som orsakats av produkten om skadan beror på att produkten har reparats felaktigt eller om, vid reparation eller utbyte, andra än Original GARDENA reservdelar har använts. Samma sak gäller för kompletteringsdelar och tillbehör.

DK Produktansvar

Vi gør udtrykkeligt opmærksom på at i henhold til produktansvarsloven er vi ikke ansvarlige for skader forårsaget af vores udstyr, hvis det skyldes uautoriserede reparationer eller hvis dele er skiftet ud og der ikke er anvendt originale GARDENA dele eller dele godkendt af os, eller hvis reparationerne ikke er udført af GARDENA-service eller en autoriseret fagmand. Det samme gælder for ekstra udstyr og tilbehør.

EST Tootevastutus

Juhime teie tähelepanu sellele, et tootevastutusseaduse kohaselt ei vastuta me meie seadmete poolt põhjustatud kahjude eest, kui need on tekkinud asjatundmatu paranduse tagajärjel või kui detaili vahetamisel ei kasutatud GARDENA originaalvaruosi ega meie poolt kasutada lubatud varuosi ja kui parandustöid ei ole teinud GARDENA klienditeenindusspetsialistid ega meie volitatud spetsialistid. Sama kehtib lisadetailide ja tarvikute kohta.

LV Produkta atbildība

Mēs skaidri norādām uz to, ka saskaņā ar Produktu atbildības likumu, mēs neatbildam par mūsu iekārtu radītiem zaudējumiem, ciktāl tos ir izraisījis neatbilstošs remonts vai daļu nomainīšana ar neoriginālām GARDENA daļām vai ne ar mūsu norādītajām detaļām un remontu nav veicis GARDENA serviss vai pilnvarots speciālists. Tas pats attiecas uz papildinošajām daļām un piederumiem.

LT Atsakomybė už produkciją

Prašome atkreipti dėmesį, kad remdamiesi „Mašinų saugos“ įstatymu, neatsakome už nuostolius, sukeltus mūsų prietaisų, jei jie atsirado dėl netinkamo remonto, arba, jei keičiant dalis, buvo naudojami neoriginalios GARDENA dalys arba dalys, kurių mes neleidome naudoti, o remontą atliko ne GARDENA serviso centras ar įgaliotas specialistas. Tas pats galioja papildomoms dalims ir priedams.

D Produkthaftung

Wir weisen ausdrücklich darauf hin, dass wir nach dem Produkthaftungsgesetz nicht für durch unsere Geräte hervorgerufene Schäden einzustehen haben, sofern diese durch unsachgemäße Reparatur verursacht oder bei einem Teileaustausch nicht unsere Original GARDENA Teile oder von uns freigegebene Teile verwendet werden und die Reparatur nicht vom GARDENA Service oder dem autorisierten Fachmann durchgeführt wird. Entsprechendes gilt für Ergänzungssteile und Zubehör.

<p>GB EU Declaration of Conformity</p> <p>The undersigned Husqvarna AB, 561 82 Huskvarna, Sweden, hereby certifies that, when leaving our factory, the units indicated below are in accordance with the harmonised EU guidelines, EU standards of safety and product specific standards. This certificate becomes void if the units are modified without our approval.</p>	<p>Description of the unit: Water Computer Laitteiden nimitys: Kastelunohjain Produktbeskrivning: Bevattningscomputer Beskrivelse af enhederne: Vandingscomputer Seadmete nimetus: Kastmiskomputer Iekārtu apzīmējums: Laistīšanas dators Gaminio pavadinimas: Laistymo kompiuteris Bezeichnung des Gerätes: Bewässerungscomputer</p>
<p>FIN EY-vaatimustenmukaisuusvakuutus</p> <p>Allakirjottanut Husqvarna AB, 561 82 Huskvarna, Sweden vakuuttaa, että allamainitut laitteet täyttävät tehtaatamme lähiesään yhdenmukaistettujen EY-direktiivien, EY-turvallisuusstandardien ja tuotekohtaisten standardien vaatimukset. Laitteisiin tehdyt muutokset, joista ei ole sovittu kanssamme, johtavat tämän vakuutuksen raukeamiseen.</p>	<p>Type: Art. No.: Tyyppi: Art.-n:o : Typ: Art.nr.: Typ: MultiControl Varenr.: 1874 Tüübid: duo Típi: duo Tipas: duo Typ: Gaminio Nr.: Art.-Nr.: Bewässerungscomputer</p>
<p>S EU Tillverkarintyg</p> <p>Undertecknad firma Husqvarna AB, 561 82 Huskvarna, Sweden, intygar härmed att nedan nämnda produkter överensstämmer med EU:s direktiv, EU:s säkerhetsstandard och produktspecifikation. Detta intyg upphör att gälla om produkten ändras utan vårt tillstånd.</p>	<p>EU directives: EY-direktiivit: EU direktiv: 2004/108/EC EU Retningslinier: Eli direktiivid: 2011/65/EC ES-direktivas: ES direktivos: EU-Richtlinien:</p>
<p>DK EU Overensstemmelse certifikat</p> <p>Undertegnede Husqvarna AB, 561 82 Huskvarna, Sweden bekræfter hermed, at enheder listet herunder, ved afsendelse fra fabrikken, er i overensstemmelse med harmoniserede EU retningslinier, EU sikkerhedsstandarder og produkt-specifikationsstandarder. Dette certifikat træder ud af kraft hvis enhederne er ændret uden vor godkendelse.</p>	<p>Harmonisierte EN: DIN EN ISO 12100</p>
<p>EST Eli vastavusdeklaratsioon</p> <p>Allakirjutatu Husqvarna AB, 561 82 Huskvarna, Sweden kinnitab, et kirjeldatud seade vastab meie poolt ringluse viidud kujul Eli harmoniseeritud direktiividele, Eli ohutusstandarditele ja tootega seotud standarditele. Meiega kooskõlastamata muudatuse tegemise korral seadmel kaotab see deklaratsioon kehtivuse.</p>	<p>Hinterlegte Dokumentation: GARDENA Technische Dokumentation M.Kugler 89079 Ulm Deposited Documentation: GARDENA Technical Documentation M.Kugler 89079 Ulm Documentation déposée: Documentation technique GARDENA M.Kugler 89079 Ulm</p>
<p>LV ES-atbilstības deklarācija</p> <p>Parakstīstijies Husqvarna AB, 561 82 Huskvarna, Sweden, Vācija apstiprina, ka sekojoši apzīmētās iekārtas, kuras mēs izplatām, savā izpildījumā atbilst harmonizētajām ES direktīvām, ES drošības standartiem un produkta specifiskajiem standartiem. Ar mūsu neapstiprinātām izmaiņām iekārtā šī deklarācija zaudē savu derīgumu.</p>	<p>Year of CE marking: 2011 CE-merkin kiinnitysvuosi: CE-Märkningsår: CE-Mærkningsår: CE-mārgistuse paigaldamise aasta: Metal, kuriais paženklinta CE-ženku: CE-marķējuma uzlikšanas gads: Anbringungsjahr der CE-Kennzeichnung:</p>
<p>LT ES Atitikties deklaracija</p> <p>Pasirašanti Husqvarna AB, 561 82 Huskvarna, Sweden patvirtina, kad žemiau nurodyti prietaisai ir jų modeliai, kuriuos paleidome į apyvartą, patenkina harmonizuotas ES direktyvas, ES saugumo standartus ir specifinius gaminio standartus. Atlikus bet kokį prietaiso pakeitimą, kuris nėra suderintas su mumis, ši deklaracija praranda galiojimą.</p>	<p>Ulm, 19.09.2013 Ulmissa, 19.09.2013 Ulm, 2013.09.19. Ulm, 19.09.2013 Ulm, 19.09.2013 Ulma, 19.09.2013 Ulm, 2013.09.19 Ulm, den 19.09.2013</p>
<p>D EG-Konformitätserklärung</p> <p>Der Unterzeichnete Husqvarna AB, 561 82 Huskvarna, Sweden bestätigt, dass die nachfolgend bezeichneten Geräte in der von uns in Verkehr gebrachten Ausführung die Anforderungen der harmonisierten EU-Richtlinien, EU-Sicherheitsstandards und produktspezifischen Standards erfüllen. Bei einer nicht mit uns abgestimmten Änderung der Geräte verliert diese Erklärung ihre Gültigkeit.</p>	<p>Authorised representative Valtuutettu edustaja Behörig Fimatecknare Teknisk direktor Volitatud esindaja Pilnvarotā persona Igaliotais atstovs Der Bevollmächtigte</p> <p><i>Reinhard Pompe</i> Reinhard Pompe (Vice President)</p>

Deutschland / Germany
GARDENA GmbH
Central Service
Hans-Lorenser-Straße 40
D-89079 Ulm
Produktfragen:
(+49) 731 490-123
Reparaturen:
(+49) 731 490-290
service@gardena.com

Albania
COBALT Sh.p.k.
Rr. Siri Kodra
1000 Tirana

Argentina
Husqvarna Argentina S.A.
Av.del Libertador 5954 –
Piso 11 – Torre B
(C1429ARP) Buenos Aires
Phone: (+54) 11 5194 5000
info.gardena@
ar.husqvarna.com

Armenia
Garden Land Ltd.
61 Tigran Street
00015 Yerevan

Australia
Husqvarna Australia Pty. Ltd.
Locked Bag 5
Central Coast BC
NSW 2252
Phone: (+61) (0) 2 4352 7400
customer.service@
husqvarna.com.au

Austria / Österreich
Husqvarna Austria GmbH
Consumer Products
Industriezeile 36
4010 Linz
Tel.: (+43) 732 77 01 01-90
consumer.service@
husqvarna.at

Azerbaijan
Firm Progress
a. Aliyev Str. 26A
10522 Baku

Belgium
GARDENA Belgium NV/SA
Sterrebeekstraat 163
1930 Zaventem
Phone: (+32) 2 720 92 12
Mail: info@gardena.be

Bosnia / Herzegovina
SILK TRADE d.o.o.
Industrijska zona Bukva bb
74260 Tešanj

Brazil
Husqvarna do Brasil Ltda
Av. Francisco Matarazzo,
1400 – 19º andar
São Paulo – SP
CEP: 05001-903
Tel: 0800-112252
marketing.br.husqvarna@
husqvarna.com.br

Bulgaria
Хускварна България ЕООД
Бул. „Андрей Лопчев“ № 72
1799 София
Tel.: (+359) 02/9753076
www.husqvarna.bg

Canada / USA
GARDENA Canada Ltd.
100 Summerlea Road
Brampton, Ontario L6T 4X3
Phone: (+1) 905 927 9330
info@gardencanada.com

Chile
Maquinarias Agroforestales
Ltda. (Maga Ltda.)
Santiago, Chile
Avda. Chesterton
8355 comuna Las Condes
Phone: (+56) 2 202 4417
Dalton@maga.cl
Zipcode: 7560330

Temuco, Chile
Avda. Valparaiso # 01466
Phone: (+56) 45 222 126
Zipcode: 4780441

China
Husqvarna (China) Machinery
Manufacturing Co., Ltd.
No. 1355, Jia Xin Rd.,
Ma Lu Zhen, Jia Ding Dist.,
Shanghai
201801
Phone: (+86) 21 59159629
Domestic Sales
www.gardena.com.cn

Colombia
Husqvarna Colombia S.A.
Calle 18 No. 68 D-31, zona
Industrial de Montevideo
Bogotá, Cundinamarca
Tel: +57 2922700 ext. 105
jairo.salazar@
husqvarna.com.co

Costa Rica
Compania Exim
Euroiberoamericana S.A.
Los Colegios, Moravia,
200 metros al Sur del Colegio
Saint Francis – San José
Phone: (+506) 297 68 83
exim_euro@racsa.co.cr

Croatia
SILK ADRIA d.o.o.
Josipa Lončara 3
10090 Zagreb
Phone: (+385) 1 3794 580
silk.adria@zg.t-com.hr

Cyprus
Med Marketing
17 Digeni Akrita Ave
P.O. Box 27017
1641 Nicosia

Czech Republic
Husqvarna Česko s.r.o.
Türkova 2319/5b
149 00 Praha 4 – Chodov
Bežplatná infolinka:
800 100 425
servis@cz.husqvarna.com

Denmark
GARDENA / Husqvarna
Consumer Outdoor Products
Salgsafdelning Danmark
Box 9003
S-200 39 Malmö
info@gardena.dk

Dominican Republic
BOSQUESA, S.R.L
Carretera Santiago Licey
Km. 5 ½
Esquina Copal II,
Santiago

Dominican Republic
Phone: (+809) 736-0333
joserbosquesa@claro.net.do

Ecuador
Husqvarna Ecuador S.A.
Arujos E1-181 y 10 de
Agosto Quito, Pichincha
Tel.: (+593) 22800739
francesca.jacom@
husqvarna.com.ec

Estonia
Husqvarna Eesti OÜ
Consumer Outdoor Products
Kesk tee 10, Aaviku küla
Rae vald
Harju maakond
75305 Estonia
kontakt.etj@husqvarna.ee

Finland
Oy Husqvarna Ab
Consumer Outdoor Products
Lauttarhankatu 8 B / P/L 3
00581 HELSINKI
info@gardena.fi

France
Husqvarna France
9/11 Allée des pierres mayettes
92635 Gemenyville Cedex
France
http://www.gardena.com/fr
N° AZUR: 0 810 00 78 23
(Prix d'un appel local)

Georgia
AL Group
1195 Beldashvili
1159 Tleilisi

Great Britain
Husqvarna UK Ltd
Preston Road
Aycliffe Industrial Park
Newton Aycliffe
County Durham
DL5 6UP
info.gardena@
husqvarna.co.uk

Greece
Π. ΠΑΠΑΔΟΠΟΥΛΟΣ ΑΕΒΕ
Λεωφ. Αθηνών 92
Αθήνα
T.K. 104 42
Ελλάδα
Τηλ. (+30) 210 51 93 100
info@papadopoulos.gr

Hungary
Husqvarna Magyarországi Kft.
Ezred u. 1-3
1044 Budapest
Telefon: (+36) 1 251-4161
vevoszolgalat.husqvarna@
husqvarna.hu

Iceland
Ö. Johnson & Kaaber
Túnguhalsi 1
110 Reykjavik
ojj@ojk.is

Ireland
Husqvarna UK Ltd
Preston Road
Aycliffe Industrial Park
Newton Aycliffe
County Durham
DL5 6UP
info.gardena@
husqvarna.co.uk

Italy
Husqvarna Italia S.p.A.
Via Como 72
23868 VALMADRERA (LC)
Phone: (+39) 0341.203.111
info@gardenaitalia.it

Japan
KAKUICHI Co. Ltd.
Sumitomo Realty &
Development Kojimachi
BLDG., 8F
5-1 Nibanncyō
Chiyoda-ku
Tokyo 102-0084
Phone: (+81) 33 264 4721
m_ishihara@kaku-ichi.co.jp

Kazakhstan
LAMED Ltd.
155/1, Tazhibayevoi Str.
050060 Almaty
IP Schmidt
Abayavenue 3B
110 005 Kostanay

Korea
Kyung Jin Trading Co.,LTD.
107-4, SunDuk Bld.,
YangJae-dong,
Sechoo-gu,
Seoul, (zipcode: 137-891)
Phone: (+82) (0)2 574-6300

Kyrgyzstan
Alye Maki
Av. Molodaya Guardir J 3
720014
Bishkek

Latvia
Husqvarna Latvija
Consumer Outdoor Products
Bākuži iela 6
LV-1024 Rīga
info@husqvarna.lv

Lithuania
UAB Husqvarna Lietuva
Consumer Outdoor Products
Atleities pl. 77C
LT-52104 Kaunas
centras@husqvarna.lt

Luxembourg
Magasins Jules Neuberg
39, rue Jacques Stas
Luxembourg-Gaspeich 2549
Case Postale No. 12
Luxembourg 2010
Phone: (+352) 40 14 01
api@neuberg.lu

Mexico
AFOSA
Av. Lopez Mateos Sur # 5019
Col. La Calma 45070
Zapopan, Jalisco
Mexico
Phone: (+52) 33 3818-3434
icornejo@afosa.com.mx

Moldova
Comvel S.R.L.
290 A Muncestii Str.
20022 Chisinau

Netherlands
GARDENA Nederland B.V.
Postbus 50176
1305 AD ALMERE
Phone: (+31) 36 521 00 00
info@gardena.nl

Neth. Antilles
Jonka Enterprises N.V.
Sta. Rosa Weg 196
P.O. Box 8200
Curaçao
Phone: (+599) 9 767 66 55
pjm@jonka.com

New Zealand
Husqvarna New Zealand Ltd.
PO Box 76-437
Manukau City 2241
Phone: (+64) (0) 9 9202410
support.nz@husqvarna.co.nz

Norway
GARDENA
Husqvarna Consumer
Outdoor Products
Salgskontor Norge
Kleiveveien 6
1540 Vestby
info@gardena.no

Peru
Husqvarna Perú S.A.
Jr. Ramón Cárcamo 710
Lima 1
Tel: (+51) 1 3320400 ext.416
juan_remujo@
husqvarna.com

Poland
Husqvarna
Poland Spółka z o.o.
ul. Wysockiego 15 b
03-371 Warszawa
Phone: (+48) 22 330 96 00
gardena@husqvarna.com.pl

Portugal
Husqvarna Portugal, SA
Lagoa - Albarraque
2635 - 595 Rio de Moura
Tel.: (+351) 21 922 85 30
Fax: (+351) 21 922 85 36
info@gardena.pt

Romania
Madex International Srl
Soseaua Odaili 117-123,
RO 013603
Bucureşti, S 1
Phone: (+40) 21 352.76.03
madex@ines.ro

Russia / Россия
ООО „Хускварна“
141400, Московская обл.,
г. Химки,
улица Ленинградская,
владение 39, стр.6
Бизнес Центр
„Химки Бизнес Парк“,
помещение ОВ02_04

Serbia
Domel d.o.o.
Autoput za Novi Sad bb
11273 Belgrade
Phone: (+381) 11 848 88 12
miroslav.jejina@domel.rs

Singapore
Hy-Ray PRIVATE LIMITED
44 Jalan Pampinon
02-08 Tat Ann Building
Singapore 577185
Phone: (+65) 6253 2277
shying@hyrray.com.sg

Slovak Republic
Husqvarna Česko s.r.o.
Türkova 2319/5b
149 00 Praha 4 – Chodov
Bežplatná infolinka:
800 154 044
servis@sk.husqvarna.com

Slovenia
Husqvarna Austria GmbH
Consumer Products
Industriezeile 36
4010 Linz
Tel.: (+43) 732 77 01 01-90
consumer.service@
husqvarna.at

South Africa
Husqvarna
South Africa (Pty) Ltd
Postnet Suite 250
Private Bag X6,
Cascades, 3202
South Africa
Phone: (+27) 33 846 9700
info@gardena.co.za

Spain
Husqvarna España S.A.
R.C./Basauri, nº 6
La Florida
28023 Madrid
Phone: (+34) 91 708 05 00
atencioncliente@gardena.es

Suriname
Agrófit n.v.
Verlengde Hogestraat # 22
Phone: (+597) 472426
agrofit@sir.net
Pobox : 2006
Paramaribo
Suriname – South America

Sweden
Husqvarna AB
S-561 82 Huskvarna
info@gardena.se

Switzerland / Schweiz
Husqvarna Schweiz AG
Consumer Products
Industriestrasse 10
5506 Mägerwil
Phone: (+41) (0) 62 887 37 90
info@gardena.ch

Turkey
GARDENA Dost Diş Ticaret
Mümesillik A.Ş.
Sanayi Cad. Adil Sokak
No: 1/B Kartal
34873 Istanbul
Phone: (+90) 216 38 93 93
info@gardena-dost.com.tr

Ukraine / Україна
ТОВ «Хусварна Україна»
вул. Васильківська, 34,
офіс 204-р
03022, Київ
Tel: (+380) 044 498 39 02
info@gardena.ua

Uruguay
FELI SA
Entre Ríos 1083 CP 11800
Montevideo – Uruguay
Tel: (+598) 22 03 18 44
info@felisa.com.uy

Venezuela
Corporación Casa y Jardín C.A.
Av. Caroní, Edif. Trezmen, B.C.
Colinas de Bello Monte,
1050 Caracas.
Tlf: (+58) 212 992 33 22
info@casayjardin.net.ve

1874-28.960.03/0315
© GARDENA
Manufacturing GmbH
D-89070 Ulm
http://www.gardena.com