

ErgoJet 3000 (EJ3000)

Art. 9332

ErgoJet 2500 (EJ2500)

Art. 9334

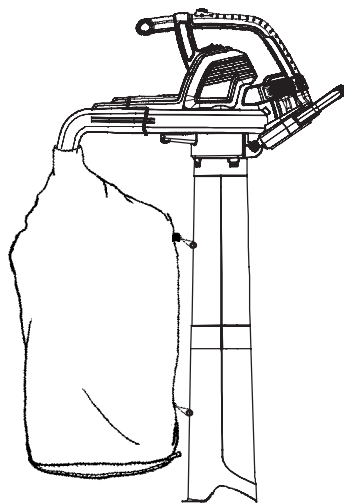

D Betriebsanleitung
Gartensauger/-Bläser

GB Operating Instructions
Electric Blower/Vac

F Mode d'emploi
Aspirateur/Souffleur électrique

NL Gebruiksaanwijzing
Bladblazer/bladzuiger

S Bruksanvisning
Lövläs/-sug

DK Brugsanvisning
Løvsuger/-blæser

FI Käyttöohje
Puutarhaimuri/-puhallin

N Bruksanvisning
Løvlåser/suger

I Istruzioni per l'uso
Soffiatore/Aspiratore elettrico

E Instrucciones de empleo
Aspirador/Soplador de jardín

P Manual de instruções
Aspirador/Soprador

PL Instrukcja obsługi
Dmuchawa/Odkurzacz ogrodowy

H Használati utasítás
Lombszívó/-fújó

CZ Návod k obsluze
Zahradní vysavač/foukač

SK Návod na obsluhu
Fukač/vysávač

GR Οδηγίες χρήσης
Φυσητήρας/αναρροφητήρας

RUS Инструкция по эксплуатации
Воздуходув/пылесос
электрический

SLO Navodilo za uporabo
Puhalnik/sesalnik

HR Upute za uporabu
Puhač/usisavač

SRB Uputstvo za rad
DUVAČ/USISIVAČ

UA Інструкція з експлуатації
Повітродувка/вакууму

RO Instrucțiuni de utilizare
Aspirator – Suflanta electrica

TR Kullanma Kılavuzu
Elektrikli Üfleyci/Vakum

BG Инструкция за експлоатация
Електрическа моторна метла/
лостосъбирач

AL Manual përdorimi
Pajisje për fryrjen/thithjen

EST Kasutusjuhend
Puhur/imur

LT Eksploatavimo instrukcija
Pūstuvai/siurblys

LV Lietošanas instrukcija
Pūtējs/putekļsūcējs

GARDENA ErgoJet 3000 (EJ3000) / ErgoJet 2500 (EJ2500)



These are the original English operating instructions.

Please read the operating instructions carefully and observe the notes given. Use these operating instructions to familiarise yourself with the product, the proper use and the safety instructions.



For safety reasons, children and young people under the age of 16, as well as people not familiar with these operating instructions, may not use this product. Persons with reduced physical or mental abilities may use the product only if they are supervised or instructed by a responsible person. Children must be supervised to ensure that they do not play with the product.

→ Keep these operating instructions in a safe place.

Contents:

1. Area of application of your GARDENA blower/vacuum	16
2. Safety instructions	17
3. Assembly	20
4. Operation	22
5. Storage	24
6. Maintenance	25
7. Troubleshooting	26
8. Technical data	27
9. Service / warranty	27

1. Area of application of your GARDENA blower/vacuum

Proper use as blower:

The GARDENA blower/vacuum is suitable when used as a blower for sweeping debris or grass clippings from driveways, sidewalks, patios, etc. and for blowing grass clippings, straw, or leaves into piles, or removing debris from corners, around joints, or between bricks.

Proper use as vacuum:

The GARDENA blower/vacuum is suitable when used as a vacuum for picking up dry material such as leaves, grass, small twigs, and bits of paper.

DANGER!
Risk of injury!



If not used properly this product can be dangerous.

The warnings and safety instructions must be followed to ensure reasonable safety and efficiency in using this product. The operator is responsible for following the warnings and instructions in this manual and on the product. Never use the product unless the guards provided by the manufacturer are in the correct position.

2. Safety instructions

→ Please note the safety instructions on the product.



WARNING: This unit can be dangerous! Careless or improper use can cause serious injury.



Read the user instructions carefully to make sure you understand all of the controls and what they do.



Do not expose to rain. Do not leave the product outdoors while it is raining.

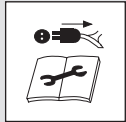

Switch off! Remove plug from mains before adjusting, cleaning or if cable is entangled or damaged.



The use of eye and ear protection is recommended. Keep in mind, that you probably won't hear bystanders, which enter the working area.

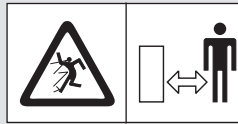

Keep bystanders away.

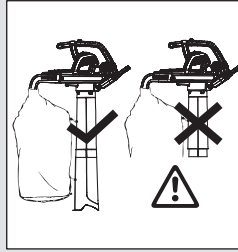

Use only with fully installed suction tube and covered collection bag in suction mode.



Wait until the rotor blades have stopped moving after switching off.



Do not use when wearing open hair, loose jewellery or loose-fitting clothes.

General Power Tool Safety Warnings



WARNING: Read all safety warnings and all instructions. Failure to follow the warnings and instructions may result in electric shock, fire and/or serious injury.

Save all warning and instructions for future reference.

The term "power tool" in the warnings refers to your mains operated (corded) power tool.

1) Work area safety

a) This product is not intended for use by persons (including children) with reduced physical, sensory or mental capabilities, or lack of experience and knowledge, unless they have been given supervision or instruction concerning the use of the product by a person responsible for their safety. Children should be supervised to ensure that they do not play with the product. Local regulations may restrict the age of the operator. Never allow children or people unfamiliar with these instructions to use the product.

Power tools are dangerous in the hands of untrained users.

b) Never operate the product while people, especially children, or pets are nearby. Distractions can cause you to lose control.

c) Never blow debris in the direction of bystanders. The operator or user is responsible for accidents or hazards occurring to other people or their property.

d) Keep work area clean and well lit. Cluttered or dark areas invite accidents.

e) Do not operate power tools in explosive atmospheres, such as in the presence of flammable liquids, gases or dust. Power tools create sparks which may ignite the dust or fumes.

2) Electrical safety

a) Power tool plugs must match the outlet. Never modify the plug in any way. Do not use any adaptor plugs with earthed (grounded) power tools. Use only on AC mains supply voltage shown on the product rating label. Unmodified plugs and matching outlets will reduce risk of electric shock.

b) Avoid body contact with earthed or grounded surfaces, such as pipes, radiators, ranges and refrigerators. There is an increased risk of electric shock if your body is earthed or grounded.

c) Do not expose power tools to rain or wet conditions. *Water entering a power tool will increase the risk electric shock.*

d) Do not abuse the cord. Never use the cord for carrying, pulling or unplugging the power tool. Keep cord away from heat, oil, sharp edges or moving parts. Before use, examine cord for damage. Replace cord if there are signs of damage or ageing. Do not use the product if the cord is damaged or worn. Immediately disconnect from the mains electricity supply if the cord is cut, or the insulation is damaged. Do not touch the electric cord until the electrical supply has been disconnected. Do not repair a cut or damaged cord. Replace it with a new one. *Damaged or entangled cords increase the risk of electric shock.*

e) The electric cord must be uncoiled. *Coiled cord can overheat and reduce the efficiency of the product. Always wind cord carefully, avoiding kinks.*

f) When operating a power tool outdoors, use an extension cord suitable for outdoor use fitted with a coupler according to IEC 60320-2-3. *Use of a cord suitable for outdoor use reduces the risk of electric shock.*

g) If operating a power tool in a damp location is unavoidable, use a residual current device (RCD) protected supply with a tripping current of not more than 30 mA. Even with a RCD installed, 100% safety cannot be guaranteed and safe working practices must be followed at all times. Check your RCD every time you use your product. *Use of an RCD reduces the risk of electric shock.*

3) Personal safety

a) Stay alert, watch what you are doing and use common sense when operating a power tool. Do not use a power tool while you are tired or under the influence of drugs, alcohol or medication. *A moment of inattention while operating power tools may result in serious personal injury.*

b) Use personal protective equipment. Always wear eye protection and hearing protection. To prevent dust irritation, the use of a dust mask is recommended. *Protective equipment such as eye protection, hearing protection, dust mask, nonskid safety shoes, or hard hat used for appropriate conditions will reduce personal injuries.*

c) Prevent unintentional starting. Ensure the switch is in the off position before connecting

to power source, picking up or carrying the tool. *Carrying power tools with your finger on the switch or energising power tools that have the switch on invites accidents.*

d) Do not overreach. Keep proper footing and balance at all times. On slopes, be extra careful and wear non-slip footwear. Do not walk backwards while operating your product. Walk, never run. Do not use ladders while operating the product. *This enables better control of the power tool in unexpected situations.*

e) Dress properly. Always wear suitable clothing, gloves, and stout shoes. Do not wear loose clothing or jewellery. Keep your hair, clothing and gloves away from moving parts. *Loose clothes, jewellery or long hair can be caught in moving parts.*

4) Power tool use and care

a) Only use the product in the manner and for the functions described in these instructions. Always direct the cord to the rear, away from the product. Do not force the power tool. Use the correct power tool for your application. *The correct power tool will do the job better and safer at the rate for which it was designed.*

b) Always make sure your product is in a safe operating condition before use. Do not use the power tool if the switch does not turn it on and off. Know how to stop the product quickly in an emergency. *Any power tool that cannot be controlled with the switch is dangerous and must be repaired.*

c) The impeller continues to rotate after your product has been switched off. *The motor must be stopped and the impeller blade no longer turning to avoid serious injury from the rotating blades.*

d) Disconnect the plug from the power source:

- before removing or replacing fully assembled debris bag;
- before leaving the product unattended for any period;
- before clearing a blockage;
- before checking, cleaning or working on the appliance;
- if the product starts to vibrate abnormally. Check immediately. Excessive vibration can cause injury.
- before passing to another person.

e) Store idle power tools out of the reach of children and do not allow persons unfamiliar with the power tool or these instructions to operate the power tool. *Power tools are dangerous in the hands of untrained users.*

f) Maintain power tools. Check for misalignment or binding of moving parts, breakage

of parts and any other condition that may affect the power tool's operation. If damaged, have the power tool repaired before use. Keep all cooling air inlets clear of debris.

Many accidents are caused by poorly maintained power tools.

g) Use the power tool and accessories in accordance with these instructions, taking into account the working conditions and the work to be performed. Use the product only in daylight or good artificial light.

Use of the power tool for operations different from those intended could result in a hazardous situation.

5) Maintenance and storage

Have your power tool serviced by a qualified repair person using only identical replacement parts.

This will ensure that the safety of the power tool is maintained.

- Keep all nuts, bolts and screws tight to be sure the product is in a safe working condition.
- Replace worn or damaged parts for safety.
- Use only genuine replacement parts and accessories.
- Inspect the debris bag regularly. If the debris bag becomes worn or damaged, replace.
- Store in a cool dry place and out of reach of children. Do not store outdoors.

Blower safety warnings

• Inspect the area before using the unit.

Remove all debris and hard objects such as rocks, glass, wire, etc., that can ricochet, be thrown, or otherwise cause injury or damage during operation.

- **Never run the unit without the proper equipment attached.** *When used as a blower, always install a blower tube. Use only recommended attachments to prevent personal injury.*
- **Do not use blower near leaf or brush fires, fireplaces, barbecue pits, ashtrays, etc.** *Proper use of the blower will help avoid spreading fire.*

• Never place objects inside the blower tubes; always direct the blowing debris away from people, animals, glass, and solid objects such as trees, automobiles, walls, etc.

The force of air can cause rocks, dirt, or sticks to be thrown or to ricochet which can hurt people or animals, break glass, or cause other damage.

• Never use for spreading chemicals, fertilizers, or any other substances.

This will prevent the spreading of toxic materials.

Vacuum safety warnings

• Stop the motor and disconnect the extension cord before opening the air inlet door or attempting to insert or remove the vacuum tubes. *The motor must be stopped and the impeller blades no longer turning to avoid serious injury from the rotating blades.*

• Inspect the area before using the unit. *Hard objects can be thrown through the collection bag or the housing and become dangerous missiles which can cause serious injury to the operator or others.*

• Do not vacuum stones, gravel, metal, broken glass, etc.

Proper use of the unit will reduce possible personal injury and/or damage to the unit.

• Do not attempt to vacuum water or other liquids. *Water or other liquids entering a power tool will increase the risk of electric shock.*

• Never run the unit without the proper equipment attached.

When used as a vacuum, always install vacuum tubes and collection bag assembly. Make sure the collection bag assembly is completely zipped when unit is running to avoid flying debris. Use only recommended attachments.

• Do not vacuum discarded matches, cigars, cigarettes, or ash from fireplaces, barbecue pits, brush piles, etc.

Avoid situations which could set the collection bag on fire. To avoid spreading fire, do not use blower near leaf or brush fires, fireplaces, barbecue pits, ashtrays, etc.

• Always use the shoulder strap when vacuuming. *This will help maintain control of the power tool.*

• Check air intake openings, elbow tube, and vacuum tubes frequently, always with the unit stopped and the power source disconnected. *Keep vents and tubes free of debris which can accumulate and restrict proper air flow. Do not use with any opening blocked. Keep free of dust, lint, hair and anything that may reduce air flow.*

Additional Safety Recommendations

Danger! Small parts could be swallowed during assembly and there is a risk of suffocation from the polybag. Keep infants away during assembly.

Warning! This machine produces an electromagnetic field during operation. This field may under some circumstances interfere with active or passive medical implants. To reduce the risk of serious or fatal injury, we recommend persons with medical implants to consult their physician and the medical implant manufacturer before operating this machine.

3. Assembly



WARNING: Stop the unit and unplug the extension cord before opening the inlet cover or attempting to install or remove the blower tube or vacuum tubes.
The motor must be stopped and the impeller blades no longer turning to avoid serious injury from the rotating blades.

Fitting the blower tube:

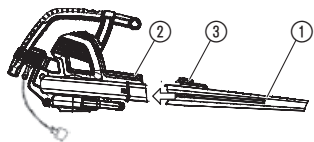

1. Align the grooves on the blower tube ① with the grooves on the blower outlet ②.
2. Push the blower tube onto the blower outlet until it snaps into place; tube is secured to blower by tube release button ③.
3. To remove the blower tube, press the tube release button ③ while pulling on tube.

NOTE: A safety switch will prevent the unit from starting if the blower tube is not installed correctly.

Fitting the vacuum tubes:

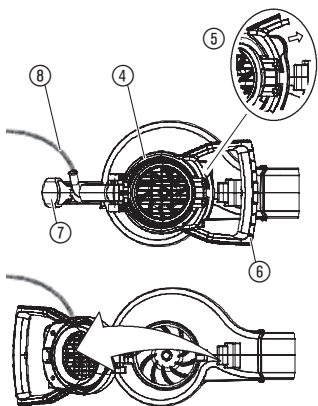

1. Open the inlet cover ④ by releasing the latch ⑤ as shown and pulling up on the vacuum assist handle ⑥.

2. Allow latch to snap into rear handle of blower ⑦. Ensure mains cable ⑧ remains free.

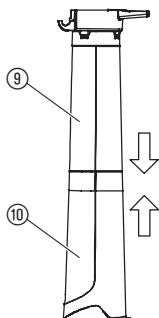

NOTE: There are 2 vacuum tubes, an upper tube ⑨ and a lower tube ⑩.

The upper tube has a hinge and hooks on one end and is cut straight on both ends. The upper tube attaches to the blower unit. The lower tube has a curved end that you point toward the ground during vacuum use. The lower tube attaches to the upper tube.

3. To attach the lower vacuum tube ⑩ to the upper vacuum tube ⑨, first align the seams of the two tubes. Then, press the two tubes together until the lower tube is fully seated in the upper tube.

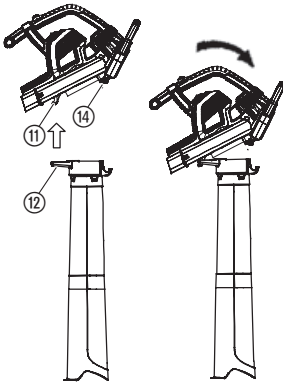

- Place the hinge ⑫ of the upper tube into the hook ⑪ on the bottom side of the unit.
- Using the ground for support ⑬, pivot the blower unit until the tube snaps into the latches of the retaining posts ⑭ on the blower unit.

NOTE: A safety switch will prevent the unit from starting if the vacuum tubes are not installed correctly.

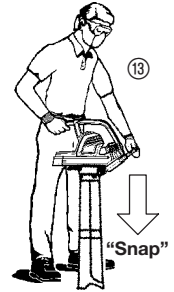

Attaching the collection bag:

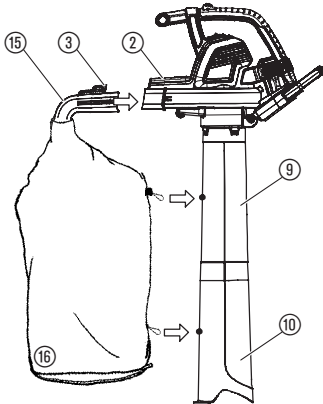

- Align the grooves on the elbow tube ⑮ with the grooves on the blower outlet ②.
- Push the elbow tube onto the blower outlet until it snaps into place; elbow tube is secured by tube release button ③.
- Clip the collection bag ⑯ to the loops on the upper vacuum tube ⑨ and lower vacuum tube ⑩.

NOTE: A safety switch will prevent the unit from starting if the elbow tube is not installed correctly.

Attaching the shoulder strap:

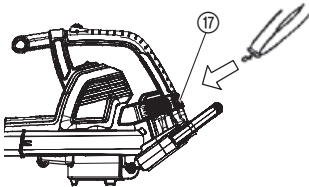

For extra support when using your unit as a vacuum, a shoulder strap is included with your unit. Attach the strap to the unit before operation. Snap the hook onto the retainer ⑰.

Converting unit from vacuum use to blower use:

1. Stop unit and unplug the extension cord.
2. Remove the elbow tube and collection bag.
3. Remove the vacuum tubes by releasing the latch on the vacuum inlet cover and rotating the cover until the tubes are released from the latches of the retaining posts.
4. Close the inlet cover and make sure it is latched closed.
5. Re-install the blower tube. Refer to FITTING THE BLOWER TUBE for instructions on how to attach this item.

NOTE: A safety switch will prevent the unit from starting if the inlet cover is not latched closed.

4. Operation



WARNING: Do not use the unit without the tubes or collection bag properly attached to avoid flying debris and/or impeller contact which can cause serious injury. Always wear gloves and use eye protection to prevent rocks or debris from being blown or ricocheting into the eyes and face which can result in blindness or serious injury.

Cables:

Use only 1.00mm² size cable up to 40 metres length maximum.

Maximum rating:

1.00mm² size cable

ErgoJet 3000 (EJ3000): 3000 W

ErgoJet 2500 (EJ2500): 2500 W

Mains cables and extensions are available from your local approved service centre. Only use extension cables specifically designed for outdoor use.

Connecting the unit – cable lock/extension cables:

Loop the extension cable ⑱ and insert it into the cable lock ⑲.

This prevents unintentional separation of the electrical connection. Then connect it to the mains cable.

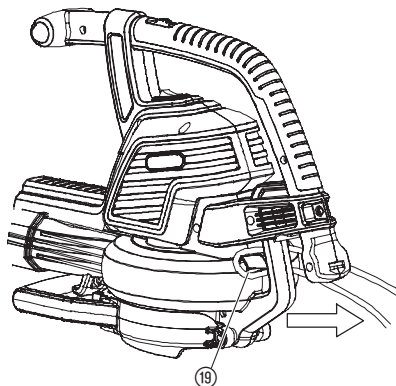
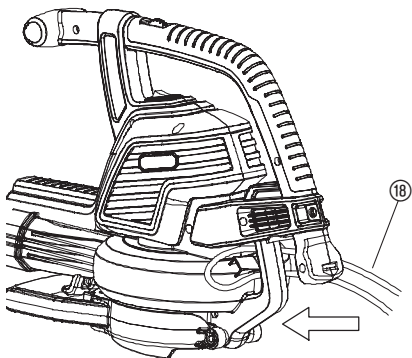

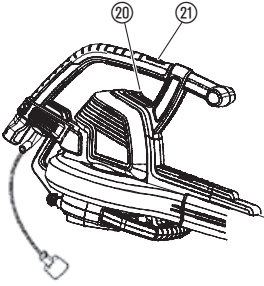
Starting the blower:**Switching the blower on:**

Move the ON/OFF switch ②① to the ON (I) position to turn on the unit.

NOTE: For ErgoJet 3000 (EJ 3000) only: The motor speed can be increased or decreased by using the variable speed control ②①.

CAUTION: To avoid causing damage to the unit, only use the variable speed control in blow mode. DO NOT attempt to use the variable speed control in vacuum mode. Lower speeds during vacuum use could allow debris to build up, stall the motor and cause unit failure.

Switching the blower off:

To stop the unit, move the ON/OFF switch ②① to the OFF (0) position.

Working positions:**Blow mode**

Use your unit as a blower for sweeping debris or grass clippings from driveways, sidewalks, patios, etc. Also, for blowing grass clippings, straw, or leaves into piles, or removing debris from corners, around joints, or between bricks.

For ErgoJet 3000 (EJ 3000) only:

Use the variable speed control to increase or decrease the motor speed during blower use.

Direct air flow by directing the blower tube down or to one side.

Always work away from solid objects such as walks, large stones, vehicles, and fences.

Clean corners by starting in corners and moving outward. This will help prevent an accumulation of debris which could fly into your face. Be careful when working near plants. The force of the air could damage tender plants.

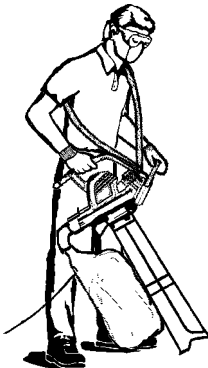
**Vacuum mode**

Use your unit as a vacuum to pick up dry material such as leaves, grass, small twigs, and bits of paper.

For best results during vacuum use, operate your unit at high speed.

Move slowly back and forth over the material as you vacuum.

Avoid forcing the unit into a pile of debris as this can clog the unit.

Keep the vacuum tube about an inch above the ground for best results.



WARNING: If the unit becomes clogged, stop the unit and unplug the extension cord. Wait until the impeller has completely stopped turning, then remove the vacuum tubes. Carefully reach into the vacuum opening and clear out the clogged debris.

This will reduce possible personal injury from the impeller.

5. Storage

Storage:

Store unit unplugged, well out of the reach of children.

1. Stop unit and disconnect from the mains electricity supply.
2. Allow motor to cool before storing or transporting.
3. Store unit with all guards in place. Position unit so that any sharp object cannot accidentally cause injury.

Extended storage:

Prepare unit for storage at the end of the season or if it will not be used for 30 days or more.

If your blower is to be stored for a period of time:

1. Stop unit and disconnect from the mains electricity supply.
2. Clean the entire unit before lengthy storage.
3. Open inlet cover and clean any dirt, grass, or debris that has collected. Inspect the blower and all tubes. Close and make sure the cover is latched.
4. Use a soft brush to clean air vents and air inlet of debris. Do not use water.
5. Store your unit and extension cord in a well ventilated area and covered, if possible, to prevent dust and dirt accumulation. Do not cover with plastic. Plastic cannot breathe and may cause condensation and eventual rust or corrosion.
6. Check entire unit for loose screws. Replace any damaged, worn, or broken parts.
7. Remove tube(s) for easier storage.

Disposal:

(in accordance with
EU-directive RL 2012/19/EU)



This product must not be added to normal household waste.
It must be disposed of in line with local environmental regulations.



WARNING: Stop the unit and disconnect the plug from the power source before making any adjustments, changing accessories, or performing maintenance.

Such preventive safety measures reduce the risk of starting the power tool accidentally.

BEFORE EACH USE

Check for loose fasteners and parts:

Keep all nuts, bolts and screws tight to be sure the product is in a safe working condition. Be sure all parts are assembled properly.

- Inlet Cover
- Blower Tube
- Vacuum Tubes
- Collection Bag

Check for damaged or worn parts:

Contact your authorized service dealer for replacement of damaged or worn parts.

- ON/OFF Switch – Ensure switch functions properly by moving the switch to the OFF position. Make sure motor stops; then restart motor and continue.
- Inlet Cover – Discontinue use of unit if inlet cover fails to latch properly or if it is damaged in any way.

AFTER EACH USE

Inspect and clean unit and labels:



DANGER! Risk of electric shocks!

Never clean the ventilation slit with a metal object.

- After each use, inspect complete unit for loose or damaged parts. Clean the unit using a damp cloth.
- Wipe off unit with a clean dry cloth.

Clean collection bag:

IMPORTANT: THE COLLECTION BAG MUST BE PROPERLY EMPTIED.

- You must properly empty and maintain the collection bag to avoid deterioration and obstruction of air flow.
- Remove the collection bag from the unit and empty after each use. Do not store bag without emptying the bag of all contents (grass, leaves, etc.).
- Wash the bag once a year. Remove the bag from the blower and turn the bag inside out. Wash the bag with a water hose. Allow the bag to hang and dry completely before you reuse the bag.



WARNING: If the unit becomes clogged, stop the unit and unplug the extension cord. Wait until the impeller has completely stopped turning, then remove the vacuum tubes. Carefully reach into the vacuum opening and clear out the clogged debris.

This will reduce possible personal injury from the impeller.

Removing an object from the air intake:

1. Remove the vacuum tubes.
2. Carefully reach into the vacuum opening and clear out the air intake area. Clear all debris from impeller.
3. Inspect the impeller for cracks. If cracked or damaged, do not use the unit. Have parts replaced by your authorized service dealer. Do not attempt to replace them yourself.

7. Troubleshooting



WARNING: Always stop unit and unplug the extension cord before performing all of the recommended remedies below except remedies that require unit to be operating.

The motor must be stopped and the impeller blades no longer turning to avoid serious injury from the rotating blades.

Problem	Possible cause	Remedy
Unit fails to operate.	1. Switch in the OFF (0) position.	1. Slide switch to ON (I) position.
	2. Extension cord disconnected.	2. Reconnect extension cord.
	3. Circuit breaker tripped, or fuse blown.	3. Reset circuit breaker or fuse.
	4. Blower tube, elbow tube, and/or vacuum tube not installed correctly.	4. Check tube installation.
	5. Collection bag is full.	5. Empty collection bag.
	6. Mechanical failure.	6. Contact your authorized service dealer.
Unit vibrates abnormally.	1. Mechanical failure.	1. Contact your authorized service dealer.
Impeller will not turn freely.	1. Debris in air intake area.	1. Clean unit. Remove any debris.
	2. Mechanical failure.	2. Contact your authorized service dealer.



For any other malfunctions, please contact the GARDENA service department. Repairs must be carried out by GARDENA service departments or specialist dealers authorised by GARDENA.

8. Technical data

	Art. no. 9332 ErgoJet 3000 (EJ3000)	Art. no. 9334 ErgoJet 2500 (EJ2500)
Motor – power consumption	Max. 3000 W	Max. 2500 W
Mains voltage	220 – 240 V	220 – 240 V
Frequency	50 Hz	50 Hz
Vacuum flow	170 l/s	170 l/s
Mulch ratio	16:1	14:1
Blow speed	Max. 310 km/h	Max. 310 km/h
Weight blower/vacuum	Max. 4.8 kg	Max. 4.8 kg
Capacity of debris bag	45 l	45 l
Sound pressure level	83 dB(A), KpA: 3.0 dB(A)	87 dB(A), KpA: 1.0 dB(A)
Sound power level $L_{WA}^{2)}$	Measured 99 dB(A) / guaranteed 102 dB(A)	Measured 102 dB(A) / guaranteed 103 dB(A)
Hand/arm vibration $a_{vhw}^{1)}$	< 3.92 m/s ²	< 2.7 m/s ²

9. Service / warranty

Warranty:

GARDENA guarantees this product for 2 years (from date of purchase). This guarantee covers all serious defects of the unit that can be proved to be material or manufacturing faults. Under warranty we will either replace the unit or repair it free of charge if the following conditions apply:

- The unit must have been handled properly and in keeping with the requirements of the operating instructions.
- Neither the purchaser or a non-authorized third party have attempted to repair the unit.

The blower tube and vacuum tubes are wearing parts and are not covered by the guarantee.

This manufacturer's guarantee does not affect the user's existing warranty claims against the dealer/seller.

If you have any problems with this product, please contact our Service or return the defective unit together with a short description of the problem – in case of guarantee, with a copy of the receipt – postage paid to one of the GARDENA Service Centres listed on the back of this leaflet.

D Produkthaftung

Wir weisen ausdrücklich darauf hin, dass wir nach dem Produkthaftungsgesetz nicht für durch unsere Geräte hervorgerufene Schäden einzustehen haben, sofern diese durch unsachgemäße Reparatur verursacht oder bei einem Teileaustausch nicht unsere originale GARDENA Teile oder von uns freigegebene Teile verwendet wurden und die Reparatur nicht vom GARDENA Service oder dem autorisierten Fachmann durchgeführt wird. Entsprechendes gilt für Ergänzungssteile und Zubehör.

GB Product Liability

We expressly point out that, in accordance with the product liability law, we are not liable for any damage caused by our units if it is due to improper repair or if parts exchanged are not original GARDENA parts or parts approved by us, and, if the repairs were not carried out by a GARDENA Service Centre or an authorised specialist. The same applies to spare parts and accessories.

F Responsabilité

Nous vous signalons expressément que GARDENA n'est pas responsable des dommages causés par ses appareils, dans la mesure où ces dommages seraient causés suite à une réparation non conforme, dans la mesure où, lors d'un échange de pièces, les pièces d'origine GARDENA n'auraient pas été utilisées, ou si la réparation n'a pas été effectuée par le Service Après-Vente GARDENA ou l'un des Centres SAV agréés GARDENA. Ceci est également valable pour tout ajout de pièces et d'accessoires autres que ceux préconisés par GARDENA.

NL Productaansprakelijkheid

Wij wijzen er nadrukkelijk op, dat wij op grond van de wet aansprakelijkheid voor producten niet aansprakelijk zijn voor schade ontstaan door onze apparaten, indien deze door onvakkundige reparatie veroorzaakt zijn, of er bij het uitwisselen van onderdelen geen gebruik gemaakt werd van onze originele GARDENA onderdelen of door ons vrijgegeven onderdelen en de reparatie niet door de GARDENA technische dienst of de bevoegde vakman uitgevoerd werd. Ditzelfde geldt voor extra-onderdelen en accessoires.

S Produktansvar

Tillverkaren är inte ansvarig för skada som orsakats av produkten om skadan beror på att produkten har reparerats felaktigt eller om, vid reparation eller utbyte, andra än Original GARDENA reservdelar har använts. Samma sak gäller för kompletteringsdelar och tillbehör.

DK Produktansvar

Vi gør udtrykkeligt opmærksom på, at vi i henhold til produktansvarsloven ikke er ansvarlige for skader forårsaget af vores udstyr, såfremt det sker på grund af uautoriserede reparationer eller hvis dele er skiftet ud og der ikke er anvendt originale GARDENA dele eller dele godkendt af os, eller hvis reparationerne ikke er udført af GARDENA-service eller en autoriseret fagmand. Det samme gælder for ekstra udstyr og tilbehør.

FI Tuotevastuu

Korostamme nimenomaan, että tuotevastuulain nojalla emme ole vastuussa laitteistamme johtuneista vahingoista, mikäli nämä ovat aiheutuneet epäasianmukaisesta korjauksesta tai osia vaihdettaessa ei ole käytetty alkuperäisiä GARDENA-varaosia tai hyväksymiämme osia ja korjauksen on suorittanut muu kuin GARDENA-huoltokeskus tai valtuuttamamme ammattihenkilö. Tämä pätee myös lisäksiin ja lisävarusteisiin.

I Responsabilità del prodotto

Si rende espressamente noto che, conformemente alla legislazione sulla responsabilità del prodotto, non si risponde di danni causati da nostri articoli se originati da riparazioni eseguite non correttamente o da sostituzioni di parti effettuate con materiale non originale GARDENA o comunque da noi non approvato e, in ogni caso, qualora l'intervento non venga eseguito da un centro assistenza GARDENA o da personale specializzato autorizzato. Lo stesso vale per le parti complementari e gli accessori.

E Responsabilidad de productos

Advertimos que conforme a la ley de responsabilidad de productos no nos responsabilizamos de daños causados por nuestros aparatos, siempre y cuando dichos daños hayan sido originados por arreglos o reparaciones indebidas, por recambios con piezas que no sean piezas originales GARDENA o bien piezas no autorizadas por nosotros, así como en aquellos casos en que la reparación no haya sido efectuada por un Servicio Técnico GARDENA o por un técnico autorizado. Lo mismo es aplicable para las piezas complementarias y accesorios.

P Responsabilidade sobre o produto

Queremos salientar que segundo a lei da responsabilidade do fabricante, nós não nos responsabilizaremos por danos causados pelo nosso equipamento, quando estes ocorrerem em decorrência de reparações inadequadas ou da substituição de peças por peças não originais da GARDENA, ou peças não autorizadas.

A responsabilidade tornar-se-à nula também depois de reparações realizadas por oficinas não autorizadas pela GARDENA. Esta restrição valerá também para peças adicionais e acessórios.

PL Odpowiedzialność za produkt

Zwracamy Państwu uwagę, że nie ponosimy odpowiedzialności za uszkodzenia naszych maszyn, bądź szkody spowodowane ich wadliwym funkcjonowaniem, powstałe na skutek nieprawidłowo przeprowadzonych napraw lub użycia nieoryginalnych części zamiennych. Naprawy winny być przeprowadzane tylko przez punkty serwisowe Husqvarna lub autoryzowane serwisy. Dotyczy to również części uzupełniających i oprzyrządowania.

H Termékszavatosság

Nyomatékosan utalunk arra a tényre, hogy a termékszavatossági törvény szerint nem kell jótállást vállalnunk azokra a károokra, amelyeket nem a mi készülékeink okoztak, ha ezeket álszzerűtlen javítás okozta vagy egy alkatrész kicserélésénél nem a mi eredeti GARDENA alkatrészeinket vagy általunk engedélyezett alkatrészeket használtak fel és a javítást nem a GARDENA szerviz vagy egy erre felhatalmazott szakember végezte. Hasonlóképpen érvényes ez a kiegészítő alkatrészekre és tartozékokra is.

CZ Odpovědnost za výrobek

Výslovně upozorňujeme na to, že podle zákona o odpovědnosti za výrobek neneseme odpovědnost za škody způsobené našimi přístroji, pokud byly způsobené neodbornou opravou nebo použitím jiných než našich originálních náhradních dílů GARDENA nebo námi schválených dílů a neprovedením opravy servisem GARDENA nebo autorizovaným odborníkem. Odpovídající platí i pro doplňkové díly a příslušenství.

SK Predmet záruky

Upozorňujeme dôrazne na to, že podľa zákona o poskytovaní záruk nezodpovedáme za škody spôsobené našimi výrobkami, v prípade, že boli boli vyvolané neodbornými opravami, výmenou dielcov, ktoré nepatria k originálnym dielom GARDENA alebo neboli nami schválené a rovnako boli spôsobené servisnými zásahmi, ktoré neboli vykonané servisom GARDENA alebo autorizovaným odborníkom. Rovnako to platí pre doplnky a príslušenstvo.

GR Ευθύνη για τα προϊόν

Σας υπενθυμίζουμε ρητά, ότι σύμφωνα με το νόμο περί ευθύνης για τα προϊόντα δεν ευθυνόμαστε για ενδεχόμενες βλάβες που προκαλούνται από τις συσκευές μας, εφόσον οφείλονται σε μία ακατάλληλη επισκευή ή σε μια αντικατάσταση τμημάτων για την οποία δεν έχουν χρησιμοποιηθεί τα πρωτότυπα ανταλλακτικά της GARDENA ή τα από μας εγκεκριμένα ανταλλακτικά και σε περίπτωση που δεν εκτελείται η επισκευή από το Τμήμα Εξυπηρέτησης Πελατών της GARDENA ή από έναν εξουσιοδοτημένο εξειδικευμένο τεχνίτη. Το ίδιο ισχύει για εξαρτήματα και συμπληρωματικά τμήματα.

SLO Jamstvo za izdelek

Pismo poudarjamo, da po zakonu jamstva za izdelek nismo odgovorni za škodo, ki bi nastala zaradi uporabe našega izdelka, prav tako tudi ne za škodo ki bi nastala zaradi nepravilnega popravila izdelka ali pri napačni zamenjavi delov, ki niso originalni deli GARDENA ali pri uporabi z naše strani potrjenih delov, ki pa niso bili vgrajeni v servisu GARDENA ali v naši pooblašteni servisni službi. Enako velja tudi za nadomestne dele in opremo.

HR Odgovornost za proizvod

Izričito napominjemo da u skladu sa Zakonom o odgovornosti za proizvode nismo odgovorni za štete uzrokovane našim uređajima ako su one izazvane nestručnim popravkom ili u slučaju zamjene dijelova nisu korišteni originalni GARDENA dijelovi ili dijelovi koje smo odobrili i popravak nije izvršio GARDENA servis ili ovlašteni stručnjak. Isto vrijedi i za dodatne dijelove i pribor.

RO Responsabilitatea legala a produsului

Menționăm în mod expres că, în concordanță cu responsabilitatea legală a produsului, nu suntem răspunzători de nici un accident provocat de produsele noastre dacă se datorează reparării necorespunzătoare sau dacă piesele de schimb nu sunt originale GARDENA sau aprobate de GARDENA, sau dacă reparațiile nu au fost efectuate de un Centru de Service GARDENA sau un specialist autorizat. Aceleași prevederi se aplică și pieselor de schimb și accesoriilor.

BG Отговорност за качество

Изрично подчертаваме, че съгласно закона за отговорност за качество, ние не носим отговорност за вредите причинени от нашите уреди, ако същите са причинени от неправилен ремонт или при подмяната на части не са използвани оригинални части на GARDENA или части одобрени от нас и ремонта не е извършен от сервиз на GARDENA или оторизиран специалист. Същото важи за допълнителните части и принадлежности.

EST Tootevastutus

Juhime teie tähelepanu sellele, et tootevastutusseaduse kohaselt ei vastuta me meie seadmete poolt põhjustatud kahjude eest, kui need on tekkinud asjatundmatu paranduse tagajärjel või kui detaili vahetamisel ei kasutatud GARDENA originaalvaruosi ega meie poolt kasutada lubatud varuosia ja kui parandustöid ei ole teinud GARDENA klienditeenindusspetsialistid ega meie volitatud spetsialistid. Sama kehtib lisadetailide ja tarvikute kohta.

LT Atsakomybė už produkciją

Nurodome, kad remdamiesi Atsakomybės už produkciją įstatymu, neatsakome už nuostolius, sukeltus mūsų prietaisy, jei jie atsirado dėl netinkamo remonto, arba, jei keičiant dalis, buvo naudojamasi neoriginalios GARDENA dalys arba dalys, kurių mes neleidome naudoti, o remontą atliko ne GARDENA servisas arba neįgaliotasis specialistas. Tas pats galioja papildomoms dalims ir priedams.

LV Produkta atbildība

Mēs skaidri norādām uz to, ka saskaņā ar Produktu atbildības likumu, mēs neatbildam par mūsu iekārtu radītiem zaudējumiem, ciktāl tos ir izraisījis neatbilstošs remonts vai daļu nomaiņa ar neoriģinālām GARDENA daļām vai ne ar mūsu norādītajām detaļām un remontu nav veicis GARDENA serviss vai pilnvarots speciālists. Tas pats attiecas uz papildinošajām daļām un piederumiem.

<p>D EG-Konformitätserklärung Der Unterzeichnete Husqvarna AB, 561 82 Huskvarna, Sweden bestätigt, dass die nachfolgend bezeichneten Geräte in der von uns in Verkehr gebrachten Ausführung die Anforderungen der harmonisierten EU-Richtlinien, EU-Sicherheitsstandards und produktspezifischen Standards erfüllen. Bei einer nicht mit uns abgestimmten Änderung der Geräte verliert diese Erklärung ihre Gültigkeit.</p>	<p>H EU-Megfelelőeségi nyilatkozat Alulírott, a Husqvarna AB, 561 82 Huskvarna, Sweden igazolja azt, hogy az alábbiakban megnevezett készülékek, az általunk forgalomba hozott kivételben teljesítik a harmonizációs EU-irányelvek, az EU biztonsági szabványok és a termékre jellemző szabványok követelményeit. Ha a készülékeken a mi beleegyezésünk nélkül változtatást végeznek, akkor ez a nyilatkozat érvényét veszti.</p>
<p>GB EU Declaration of Conformity The undersigned Husqvarna AB, 561 82 Huskvarna, Sweden hereby certifies that, when leaving our factory, the units indicated below are in accordance with the harmonised EU guidelines, EU standards of safety and product specific standards. This certificate becomes void if the units are modified without our approval.</p>	<p>CZ Prohlášení o shodě EU Podepsaný Husqvarna AB, 561 82 Huskvarna, Sweden potvrzuje, že dále uvedené přístroje v rámci do provozu uvedení provedení splňují požadavky harmonizovaných směrnic EU, bezpečnostních norem EU a norem specifických pro výrobek. Při námi neschválené změně přístrojů ztrácí toto prohlášení platnost.</p>
<p>F Certificat de conformité aux directives européennes Le constructeur, soussigné : Husqvarna AB, 561 82 Huskvarna, Sweden déclare qu'à la sortie de ses usines le matériel neuf désigné ci-dessous étai conforme aux prescriptions des directives européennes énoncées ci-après et conforme aux règles de sécurité et autres règles qui lui sont applicables dans le cadre de l'Union européenne. Toute modification portée sur ce produit sans l'accord express de GARDENA supprime la validité de ce certificat.</p>	<p>SK EU-Vyhlasenie o zhode Nižšie uvedená firma Husqvarna AB, 561 82 Huskvarna, Sweden vyhlasuje, že uvedené zariadenia, ktoré uviedla na trh v tomto vyhotovení, spĺňajú požiadavky harmonizovaných smerníc EU, bezpečnostných noriem EU a noriem špecifických pre výrobok. Pri zmene zariadenia, ktorá nebola odsúhlasená výrobcom stráca toto vyhlásenie platnosť.</p>
<p>NL EU-overeenstemmingsverklaring Ondergetekende Husqvarna AB, 561 82 Huskvarna, Sweden bevestigt, dat de volgende genoemde apparaten in de door ons in de handel gebrachte uitvoering voldoen aan de eis van, en in overeenstemming zijn met de EU-richtlijnen, de EU-veiligheidsstandaard en de voor het product specifieke standaard. Bij een niet met ons afgestemde verandering aan de apparaten verliest deze verklaring haar geldigheid.</p>	<p>GR Δήλωση Συμμόρφωσης προς τις Οδηγίες της ΕΕ Η υπογράφουσα Husqvarna AB, 561 82 Huskvarna, Sweden δηλώνει, ότι τα εξής αναφερόμενα εκδοόμενα από την εταιρία μας προϊόντα ανταποκρίνονται σε όλες τις εφαρμόσιμες προδιαγραφές της ΕΕ, στα πρότυπα ασφαλείας της ΕΕ και στα ειδικά για το προϊόν πρότυπα. Σε μία μη συμφωνημένη με την εταιρία μας τροποποίηση των συσκευών αυτή η δήλωση χάνει την ισχύ της.</p>
<p>S EU Tillverkarintyg Undertecknad firma Husqvarna AB, 561 82 Huskvarna, Sweden intygar härmed att nedan nämnda produkter överensstämmer med EU:s direktiv, EU:s säkerhetsstandard och produktspecifikation. Detta intyg upphör att gälla om produkten ändras utan vårt tillstånd.</p>	<p>SLO EU-izjava o skladnosti Podpisani proizvajalca «Husqvarna AB, 561 82 Huskvarna, Sweden» s podpisom potrjuje, da sledeće opisana naprava, ki smo jo poslali na tržišče izpolnjuje zahteve harmoniziranih standardov ES-smernic, ES-varnostnih standardov in izdelku specifičnih standardov. V primeru spremembe na navpični brez našega pisnega dovoljenja ta izjava izgubi svojo pomen in veljavnost.</p>
<p>DK EU Overensstemmelse certifikat Undertegnede Husqvarna AB, 561 82 Huskvarna, Sweden bekræfter hermed, at enheder listed herunder, ved afsendelse fra fabrikken, er i overensstemmelse med harmoniserede EU retningslinjer, EU sikkerheds standarder og produkt specifikations standarder. Dette certifikat træder ud af kraft hvis enhederne er ændret uden vor godkendelse.</p>	<p>HR Izjava o skladnosti EU-a Dolje potpisana tvrtka Husqvarna AB, 561 82 Huskvarna, Sweden ovime potvrđuje da dolje navedeni uređaji u izvedbi plaširanoj na tržište ispunjavaju zahtjeve harmoniziranih EU smjernica, EU sigurnosnih normi i normi za određene proizvode. Ova izjava postaje ništavna u slučaju izmjene uređaja koje nismo odobrili.</p>
<p>FI EU-yhdenmukaisuusvakuutus Allekirjoittanut Husqvarna AB, 561 82 Huskvarna, Sweden vakuuttaa, että alla mainittu laiteet täyttävät tehtaaltamme lähtiesään yhdenmukaisistettujen EU-direktiivien, EU-turvallisuusstandardien ja tuotekohtaisten standardien vaatimukset. Laitteisiin tehyd muutokset, joista ei ole sovittu kanssamme, joutavat tämän vakuutuksen raukaamiseen.</p>	<p>RO UE-Certificat de conformitate Prin prezenta Husqvarna AB, 561 82 Huskvarna, Sweden, certifica faptul ca, in momentul in care produsele mentionate mai jos ies din fabrica sunt in concordanta cu directivele UE, standardele de siguranta UE si standardele specifice ale produsului UE. Acest certificat devine nul in cazul modificării aparatului fără aprobarea noastră.</p>
<p>I Dichiarazione di conformità alle norme UE La sottoscritta Husqvarna AB, 561 82 Huskvarna, Sweden certifica che il prodotto qui di seguito indicato, nei modelli da noi commercializzati, è conforme alle direttive armonizzate UE nonché agli standard di sicurezza e agli standard specifici di prodotto. Qualunque modifica apportata al prodotto senza nostra specifica autorizzazione invalida la presente dichiarazione.</p>	<p>BG ЕС-Декларация за съответствие Подписаната фирма Husqvarna AB, 561 82 Huskvarna, Sweden декларира, че описаните по-долу уреди, пуснати в продажба съгласно нашата спецификация, изпълняват изискванията на хармонизираните ЕС-директиви, ЕС-стандартите за безопасност и специфичните производствени стандарти. При промяна на уреда, която не е съгласувана с нас, тази декларация губи своята валидност.</p>
<p>E Declaración de conformidad de la UE El que suscribe Husqvarna AB, 561 82 Huskvarna, Sweden declara que la presente mercancía, objeto de la presente declaración, cumple con todas las normas de la UE, en lo que a normas técnicas, de homologación y de seguridad se refiere. En caso de realizar cualquier modificación en la presente mercancía sin nuestra previa autorización, esta declaración pierde su validez.</p>	<p>EST Eli vastusdeklaratsioon Allkirjutanud Husqvarna AB, 561 82 Huskvarna, Sweden kinnitab, et kirjeldatud seade vastab meie poolt riigusse viidud kujul ELi harmoniseeritud direktiividele, ELi ohutusstandarditele ja tootega seotud standarditele. Meiega kooskõlastamata muudatuste tegemise korral seadmel kaotab see deklaratsioon kehtivuse.</p>
<p>P Certificado de conformidad da UE Os abaixo mencionados Husqvarna AB, 561 82 Huskvarna, Sweden, por este meio certificam que ao sair da fábrica os aparelhos abaixo mencionados estão de acordo com as direttrizes harmonizadas da UE, padrões de segurança e de produtos específicos. Este certificado ficará nulo se as unidades forem modificadas sem a nossa aprovação.</p>	<p>LT ES Atitikties deklaracija Pasirašanti nurodė Husqvarna AB, 561 82 Huskvarna, Sweden patvirtina, kad žemiau įvardyti prietaisai ir jų modeliai, kurie buvo pagaminti mūsų gamyklose atitinka ES direktyvas, ES saugumo standartus ir specifinius gaminių standartus. Atlikus bet kokį prietaiso pakeitimą, kuris nėra suderintas su mumis, ši deklaracija praranda galiojimą.</p>
<p>PL Deklaracja zgodności Unii Europejskiej Husqvarna AB, 561 82 Huskvarna, Sweden potwierdza, że poniżej określone urządzenia w wersji oferowanej przez nas do sprzedaży spełniają wymagania zharmonizowanych dyrektyw Unii Europejskiej, standardu bezpieczeństwa Unii Europejskiej i standardu specyficznego dla tego typu produktów. W przypadku zmiany urządzenia, która nie została z nami uzgodniona, niniejsza deklaracja traci moc obowiązującą.</p>	<p>LV ES-atbilstības deklarācija Parakstīstusies Husqvarna AB, 561 82 Huskvarna, Sweden, Vācija apstiprina, ka sekojoši apzīmētās iekārtas, kuras mēs izplatām, savā izpildījumā atbilst harmonizētajām ES direktīvām, ES drošības standartiem un produkta specifiskajiem standartiem. Ar mūsu neapstiprinātām izmaiņām iekārtā šī deklarācija zaudē savu derīgumu.</p>

<p>Bezeichnung der Geräte: Description of the units: Désignation du matériel : Omschrijving van de apparaten: Produktbeskrivning: Beskrivelse af produktet: Laitteiden nimitys: Descrizione dei prodotti: Descripción de la mercancía: Descrição dos aparelhos: Nazwa urządzeń: A készülékek megnevezése: Označení přístrojů: Označenie zariadenia: Ονομασία της συσκευής: Opis naprave: Oznaka uređaja: Descrierea articolelor: Обозначение на уредите: Seadmete nimetus: Prietaisų pavadinimas: Iekārtu apzīmējums:</p>	<p>Bläser/Sauger Blower/vacuum Souffleur/aspirateur Bladblazer/bladzuiger Blås/sug Bläser/suger Puhallin/imuri Soffiatore/aspiratore Soplador/aspirador Soprador/aspirador Dmuchawa/odkurzac Levélűfűvő/szívó Fukar/vysavač Fukač/vysavač Φυσητήρας/αναροφητήρας Puhallik/sesalnik Puhač/usisavač Refulator/aspirator Духалка/вакуум Puhur/imur Prietaisų siurblys Pūtejs/putekļsūcējs</p>	<p>Schall-Leistungspegel: Noise level: Puissance acoustique : Geluidsniveau: Ljudnivá: Lydtryksniveau: Melun tehotas: Livello rumorosità: Nivel sonoro: Nível de ruído: Poziom natężenia dźwięku: Zajteljesítmény szint: Hluková hladina výkonu: Výkonová hladina hluku: Επίπεδο ισχύος ήχου: Nivo hrupa: Razina zvučne snage: Nivel de putere acustică: Ниво на шума: Helivõimsuse tase: Garsio stiprumo lygis: Τροκήριου jaudas līmenis:</p> <p>gemessen / garantiert measured / guaranteed mesurée / garantie gemeten / gegarandeerd uppmätt / garanterad afmålt / garanti mitattu / taattu testato / garantito medido / garantizado medido / garantido zmierzono / gwarantowane mért / garantált naměřeno / garantovano meraná / garantovaná μετρήθηκαν / εγγυημένα izmerjeno / zagotovljeno izmjereno / garantirano māsurat / garantat измерено / гарантирано mõeldetud / garanteeritud išmatuotas / garantuotas izmērētais / garantētais</p>
<p>Typen: Types: Types : Type: Type: Type: Type: Type: Type: Type: Type: Type: Type: Type: Type:</p>	<p>Típusok: Típu: Típu: Típu: Típu: Típu: Típu: Típu: Típu: Típu: Típu: Típu: Típu: Típu:</p>	<p>Art.-Nr.: Art. No.: Référéncie : Art.n.r.: Art.nr.: Art. nr.: Tuoten:o Art.: Art. No: Art. no: Nr artykulu:</p> <p>Cikkszám: Číslo artiklu: Art.: Αριθ. ειδους: Art št.: br. art. Nr art.: Αρτ. номер: Toote nr : Gaminio nr. : Izstr.:</p>
<p>ErgoJet 3000 (EJ3000) ErgoJet 2500 (EJ2500)</p>	<p>9332 9334</p>	<p>Art. 9332: Art. 9334:</p> <p>99 dB(A) / 102 dB(A) 102 dB(A) / 103 dB(A)</p> <p>Anbringungsjahr der CE-Kennzeichnung: Year of CE marking: Année d'apposition du marquage CE : Installatiejaar van de CE-aanduiding: Märkningsår: CE-Mærkningsår: CE-merkin kiinnitysvousi: Anno di applicazione della certificazione CE: Colocación del distintivo CE: Ano de marcação pela CE: Rok nariadenia oznakovania CE: CE-jelzés elhelyezésének éve:</p> <p>Rok umistění značky CE: Rok udelenia značky CE: Έτος σήματος CE: Leto namestitve CE-oznake: Godina dobivanja CE oznake: Anul de marcare CE: Година на поставяне на CE-маркировка: CE-märgistuse paigaldamise aasta: Metal, kada pažymėta CE-ženklui: CE-marķējuma uzlikšanas gads:</p> <p>2011</p>
<p>EU-Richtlinien: EU directives: Directives européennes : EU-richtlijnen: EU directiv: EU Retningslinier: EY-direktiivit: Direttive UE: Normativa UE: Directrices da UE: Dyrektywy Unii Europejskiej: EU-irányelvek: Směrnice EU: EU-Predpisy: Οδηγίες της ΕΕ:</p>	<p>ES-smernice: EU smjernice: Directive UE: EC-директиви: ELI direktiivid: EU direktivos: ES-direktivās:</p> <p>2006/42/EG 2004/108/EG bis 19.04.2016 2014/30/EG ab 20.04.2016 2000/14/EG 2011/65/EG</p> <p>Geltende Normen: / Applicable standards: EN ISO 12100 IEC 60335-2-100</p> <p>Hinterlegte Dokumentation: GARDENA Technische Dokumentation, M. Kugler</p> <p>Deposited Documentation: GARDENA Technical Documentation, M. Kugler</p> <p>Documentation déposée: Documentation technique GARDENA, M. Kugler</p>	<p>Ul'm, den 02.06.2015 Ul'm, 02.06.2015 Fait à Ul'm, 02.06.2015 Ul'm, 02-06-2015 Ul'm, 2015.06.02 Ul'm, 02.06.2015 Ul'missa, 02.06.2015 Ul'm, 02.06.2015 Ul'm, 02.06.2015 Ul'm, 02.06.2015 Ul'm, 02.06.2015 Ul'm, 02.06.2015 Ul'm, 02.06.2015 Ul'm, 02.06.2015 Ul'm, 02.06.2015 Ul'm, 02.06.2015 Ul'm, 02.06.2015 Ul'm, 02.06.2015 Ul'm, 02.06.2015 Ul'm, 02.06.2015 Ul'm, 02.06.2015 Ul'm, 02.06.2015 Ul'm, 02.06.2015 Ul'm, 02.06.2015 Ul'm, 02.06.2015 Ul'm, 02.06.2015</p> <p>Der Bevollmächtigte Authorised representative Le mandataire De gevolmachtigde Auktoriserad representant Autoriseret repræsntant Valtuutettu edustaja Persona delegata La persona autorizada O representante Painomocnik Mgħatalmazzott Zplnomocnēnec Splnomocnený Ο εξουσιοδοτημένος Pooblaščenec Ovlaštena osoba Conducerea tehnică Упълномощен Volitatud esindaja Igaliolasis atstovas Pilnvarotā persona</p> <p> Reinhard Pompe Vice President</p>

Deutschland / Germany

GARDENA GmbH
Central Service
Hans-Lorenser-Straße 40
D-89079 Ulm
Produktfragen:
(+49) 731 490-123
Reparaturen:
(+49) 731 490-290
service@gardena.com

Albania

COBALT Sh.p.k.
Rr. Siri Kodra
1000 Tirana
Argentina
Husqvarna Argentina S.A.
Av.del Libertador 5954 –
Piso 11 – Torre B
(C1428ARP) Buenos Aires
Phone: (+54) 11 5194 5000
info.gardena@
ar.husqvarna.com

Armenia

Garden Land Ltd.
61 Tigran Mets
0005 Yerevan

Australia

Husqvarna Australia Pty. Ltd.
Locked Bag 5
Central Coast BC
NSW 2252
Phone: (+61) (0) 2 4352 7400
customer.service@
husqvarna.com.au

Austria / Österreich

Husqvarna Austria GmbH
Industriezeile 36
4010 Linz
Tel.: (+43) 732 7701 01-485
service.gardena@
husqvarnagroup.com

Azerbaijan

Firm Progress
a. Aliyev Str. 26A
1052 Baku

Belgium

GARDENA Belgium NV/SA
Sterrebeekstraat 163
1930 Zaventem
Phone: (+32) 2 720 92 12
Mail: info@gardena.be

Bosnia / Herzegovina

SILK TRADE d.o.o.
Industrijska zona Bukva bb
74260 Tešanj

Brazil

Husqvarna do Brasil Ltda
Av. Francisco Matarazzo,
1400 – 19º andar
São Paulo – SP
CEP: 05001-903
Tel: 0800-112252
marketing.br.husqvarna@
husqvarna.com.br

Bulgaria

Хускварна България ЕООД
Бул. „Андрей Липчев“ № 72
1799 София
Тел.: (+359) 02/9753076
www.husqvarna.bg

Canada / USA

GARDENA Canada Ltd.
100 Summerlea Road
Brampton, Ontario L6T 4X3
Phone: (+1) 905 792 9330
info@gardena.canada.com

Chile

Maquinarias Agroforestales
Ltda. (Maga Ltda.)
Santiago, Chile
Avda. Chesterton
8355 comuna Las Condes
Phone: (+56) 2 202 4417
Dalton@maga.cl
Zipcode: 7560330
Temuco, Chile
Avda. Valparaiso # 01466
Phone: (+56) 45 222 126
Zipcode: 4780441

China

Husqvarna (China) Machinery
Manufacturing Co., Ltd.
No. 1355, Jia Xin Rd.,
Ma Lu Zhen, Jia Ding Dist.,
Shanghai
201801
Phone: (+86) 21 59159629
Domestic Sales
www.gardena.com.cn

Colombia

Husqvarna Colombia S.A.
Calle 18 No. 88 D-31, zona
Industrial de Montevideo
Bogotá, Cundinamarca
Tel. 571 2922700 ext. 105
jairo.salazar@
husqvarna.com.co

Costa Rica

Compania Exim
Euroiberoamericana S.A.
Los Colegios, Moravia,
200 metros al Sur del Colegio
Saint Francis – San José
Phone: (+506) 297 68 83
exim_euro@racsa.co.cr

Croatia

SILK ADRIA d.o.o.
Josipa Lončara 3
10090 Zagreb
Phone: (+385) 1 3794 580
silk.adria@zg.t-com.hr

Cyprus

Med Marketing
17 Digeni Akrita Ave
P.O. Box 27017
1641 Nicosia

Czech Republic

Husqvarna Česko s.r.o.
Türkova 2319/5b
149 00 Praha 4 – Chodov
Bezplatná infolinka:
800 100 425
servis@cz.husqvarna.com

Denmark

GARDENA / Husqvarna
Consumer Outdoor Products
Salgsafdelning Danmark
Box 9003
S-200 39 Malmö
info@gardena.dk

Dominican Republic

BOSQUESA, S.R.L
Carretera Santiago Licey
Km. 5 ½
Esquina Copal II,
Santiago
Dominican Republic
Phone: (+809) 736-0333
joserbosquesa@claro.net.do

Ecuador

Husqvarna Ecuador S.A.
Arupos E1-181 y 10 de
Agosto Quito, Pichincha
Tel. (+593) 22800739
francisco.jacom@
husqvarna.com.ec

Estonia

Husqvarna Eesti OÜ
Consumer Outdoor Products
Kesk tee 10, Aaviku küla
Rae vald
Harju maakond
75305 Estonia
kontakt.etj@husqvarna.ee

Finland

Oy Husqvarna Ab
Consumer Outdoor Products
Lauttarhankatu 8 / P.L 3
00581 HELSINKI
info@gardena.fi

France

Husqvarna France
9/11 Allée des pierres mayettes
92635 Gennevilliers Cedex
France
http://www.gardena.com/fr
N° AZUR: 0 810 00 78 23
(Prix d'un appel local)

Georgia

ALD Group
Belashvili 8
1159 Tleilisi

Great Britain

Husqvarna UK Ltd
Preston Road
Aycliffe Industrial Park
Newton Aycliffe
County Durham
DL5 6UP
info.gardena@
husqvarna.co.uk

Greece

Π.ΠΑΠΑΔΟΠΟΥΛΟΣ ΑΕΒΕ
Λεωφ. Αθηνών 92
Αθήνα
Τ.Κ.104 42
Ελλάδα
Τηλ. (+30) 210 5193100
info@papadopoulos.com.gr

Hungary

Husqvarna Magyarország Kft.
Ezered u. 1-3
1044 Budapest
Telefon: (+36) 1 251-4161
vevoszolgalat.husqvarna@
husqvarna.hu

Iceland

Ó. Johnson & Kaaber
Tunguhsalsi 1
110 Reykjavik
ooj@oik.is

Ireland

Husqvarna UK Ltd
Preston Road
Aycliffe Industrial Park
Newton Aycliffe
County Durham
DL5 6UP
info.gardena@
husqvarna.co.uk

Italy

Husqvarna Italia S.p.A.
Via Como 72
23868 VALMADRERA (LC)
Phone: (+39) 0341.203.111
info@gardenaitalia.it

Japan

KAKUICHI Co. Ltd.
Sumitomo Realty &
Development Kojimachi
BLDG., 8F
5-1 Nibanncyo
Chiyoda-ku
Tokyo 102-0084
Phone: (+81) 33 264 4721
m_ishihara@kaku-ichi.co.jp

Kazakhstan

LAMED Ltd.
155/1, Tazhibayevoi Str.
050060 Almaty
IP Schmidt
Abayavenue 3B
110 005 Kostanay

Korea

Kyung Jin Trading Co., LTD.
107-4, SunDuk Bld.,
YangJae-dong,
Seocho-gu,
Seoul, (zipcode: 137-891)
Phone: (+82) (0)2 574-6300

Kyrgyzstan

Alye Maki
av. Molodaya Guardir J 3
720014
Bishkek

Latvia

Husqvarna Latvija
Consumer Outdoor Products
Bārkūžu iela 6
LV-1024 Rīga
info@husqvarna.lv

Lithuania

UAB Husqvarna Lietuva
Consumer Outdoor Products
Ateities pl. 77C
LT-52104 Kaunas
centras@husqvarna.lt

Luxembourg

Magasin Jules Neuberg
33, rue Jacques Stas
LUXEMBOURG-Gasperich 2549
Case Postale No. 12
Luxembourg 2010
Phone: (+352) 40 14 01
api@neuberg.lu

Mexico

AFOSA
Av. Lopez Mateos Sur # 5019
Col. La Calma 45070
Zapopan, Jalisco
Mexico
Phone: (+52) 33 3818-3434
icornejo@afosa.com.mx

Moldova

Comvel S.R.L.
290A Muncesti Str.
2002 Chisinau

Netherlands

GARDENA Nederland B.V.
Postbus 50176
1305 AD ALMERE
Phone: (+31) 36 521 00 00
info@gardena.nl

Neth. Antilles

Jonka Enterprises N.V.
Sta. Stoa Weg 196
P.O. Box 8200
Curaçao
Phone: (+599) 9 767 6655
pjm@jonka.com

New Zealand

Husqvarna New Zealand Ltd.
PO Box 76-437
Manukau City 2241
Phone: (+64) (0) 9 9202410
support.nz@husqvarna.co.nz

Norway

GARDENA
Husqvarna Consumer
Outdoor Products
Salgskontor Norge
Klevereienv 6
1540 Vestby
info@gardena.no

Peru

Husqvarna Perú S.A.
Jr. Ramón Cárcamo 710
Lima 1
Tel: (+51) 1 3320400 ext. 416
javier.remuzgo@
husqvarna.com

Poland

Husqvarna
Poland Spółka z o.o.
ul. Wysockiego 15 b
03-371 Warszawa
Phone: (+48) 22 330 96 00
gardena@husqvarna.com.pl

Portugal

Husqvarna Portugal, SA
Lagoa - Albarraque
2635 - 595 Rio de Mouro
Tel.: (+351) 21 922 85 30
Fax: (+351) 21 922 85 36
info@gardena.pt

Romania

Madex International Srl
Soseaua Odaii 117-123,
RO 013603 Bucuresti, S1
Phone: (+40) 21 352.76.03
madex@mes.ro

Russia / Россия

ООО „Хускварна“
141400, Московская обл.,
г. Химки,
улица Ленинградская,
владение 39, стр.6.
Бизнес Центр
„Химки Бизнес Парк“,
помещение 0802.04,
http://www.gardena.ru

Serbia

Domel d.o.o.
Autoput za Novi Sad bb
11273 Belgrade
Phone: (+381) 118 488 88 12
miroslav.jejina@domel.rs

Singapore

Hy-RAY PRIVATE LIMITED
40 Jalan Pemimpin
#02-08 Tat Ann Building
Singapore 577185
Phone: (+65) 6253 2277
shying@hyray.com.sg

Slovak Republic

Husqvarna Cesko s.r.o.
Türkova 2319/5b
149 00 Praha 4 – Chodov
Bezplatná infolinka:
800 154 044
servis@sk.husqvarna.com

Slovenia

Husqvarna Austria GmbH
Industriezeile 36
4010 Linz
Tel.: (+43) 732 77 01 01-485
service.gardena@
husqvarnagroup.com

South Africa

Husqvarna
Husqvarna (Pty) Ltd
Postnet Suite 250
Private Bag X6,
Cascades, 3202
South Africa
Phone: (+27) 33 846 9700
info@gardena.co.za

Spain

Husqvarna España S.A.
C/ Basauri, nº 6
La Florida
28023 Madrid
Phone: (+34) 91 708 05 00
atencioncliente@gardena.es

Suriname

Agrofix n.v.
Verlengde Hogestraat # 22
Phone: (+597) 472426
agrofix@sr.net
Pobox : 2006
Paramaribo
Suriname – South America

Sweden

Husqvarna AB
S-561 82 Huskvarna
info@gardena.se

Switzerland / Schweiz

Husqvarna Schweiz AG
Consumer Products
Industriestrasse 10
5506 Mägenwil
Phone: (+41) (0) 62 887 37 90
info@gardena.ch

Turkey

GARDENA Dost Diş Ticaret
Müesseslik A.Ş.
Sanayi Çad. Adil Sokak
No: 1/B Kartal
34873 Istanbul
Phone: (+90) 216 38 93 939
info@gardena-dost.com.tr

Ukraine / Україна

ТОВ „Хусварна Україна“
вул. Васильківська, 34,
офіс 204-р
03022, Київ
Тел: (+380) 44 998 39 20
info@gardena.ua

Uruguay

FELI SA
Entre Ríos 1083 CP 11800
Montevideo – Uruguay
Tel: (+598) 22 03 18 44
info@felisa.com.uy

Venezuela

Corporación Casa y Jardín C.A.
Av. Caroni, Edif. Trezmen, PB.
Colinas de Bello Monte,
1050 Caracas.
Tlf: (+58) 212 992 33 22
info@casayjardin.net.ve

115446526 15.06.2015
Husqvarna AB
SE-561 82 Huskvarna
Sweden
9332-20 960 03/0615
© GARDENA Manufacturing GmbH
D-89070 Ulm
http://www.gardena.com