

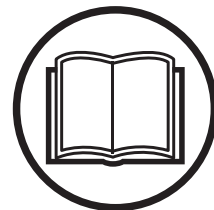

操作手册 **Operator's manual**

543RBS



请认真阅读本操作手册，确保在充分理解各项说明之后再使用机器。
Please read the operator's manual carefully and make sure you understand the instructions before using the machine.

Chinese
English

符号说明

符号。

警告！清理锯、割灌机或打草机如果使用不当或疏忽会十分危险，可能导致操作员或周围人严重受伤甚至死亡。阅读并且理解本《操作手册》的内容极其重要。



请认真阅读本操作手册，确保在充分理解各项说明之后再使用机器。



请务必配戴：

- 保护头盔（在有物体掉落风险的情况下）
- 经检验合格的听觉保护设备
- 经检验合格的眼部保护设备



输出轴最大速度 (rpm)



本产品符合适用的 EC 指令的要求。



注意抛掷物和反弹物。



机器操作员必须确保作业过程中 15 米范围内无任何人员或动物。



装有锯片或打草刀片的机器在锯片或刀片接触固定物体会猛地甩向一侧。这被称为甩刀。锯片或刀片能切断手臂或腿部。务必使人员和动物与机器保持至少 15 米远的距离。



用于指示手柄位置调节止点的箭头。



点火和熄火：将风门设在阻风位置。



注油泵



务必戴上检验合格的保护手套。



穿上坚固的防滑靴。



只能使用非金属柔性切割锯片，即打草头配有打草绳。



在环境中的噪音释放符合欧盟指令。本机的噪音释放在“技术参数”一章和产品标签上有详细说明。



使您的身体部位远离发热表面。



有关机器上的其他符号/标识，请参考适用于特定市场的特殊认证要求。

进行任何检查或者维护之前，请将停止开关扳到 STOP（停止）位置以关闭引擎。



务必戴上检验合格的保护手套。



必须经常清洗。



视检。



目录

目录

符号说明	
符号	2
目录	
目录	3
启动前应注意以下事项:	3
引言	
尊敬的客户:	4
构造图示说明	
割灌机的构造图示说明	5
一般安全须知	
重要事项	6
个人防护装备	6
机器安全设备	7
切割设备	9
组装	
安装柔性驱动轴	11
连接油门电缆和停止开关导线	11
安装J型手柄	11
安装刀片和打草头	12
安装运输防护罩	13
调整背带和割灌机	13
拆装两件式轴	14
燃油处理	
燃油安全须知	16
燃油	16
加燃油	17
启动与停止	
启动前检查	18
启动与停止	18
操作方法	
一般工作须知	20
维护	
化油器	23
冷却系统	23
空气滤清器	23
燃油滤清器	23
两件式轴	24
斜齿轮	24
火花塞	24
驱动轴	24
维护计划	26
技术参数	
技术参数	27
欧盟一致性声明	28

启动前应注意以下事项:

请详细阅读操作手册。



警告！长期接触噪音会导致永久性听力损伤。因此，请务必佩戴检验合格的听觉保护设备。



警告！任何情况下，未经制造厂的许可，不得修改本机的设计。必须使用原厂零件。未经许可擅自修改，或使用未经认可的零件，可能会对操作员或其他人员造成严重的伤害或死亡。



警告！清理锯、割灌机或打草机如果使用不当或疏忽会十分危险，可能导致操作员或周围人严重受伤甚至死亡。阅读并且理解本《操作手册》的内容极其重要。

引言

尊敬的客户：

感谢您选购 Husqvarna 产品！Husqvarna 的历史可以追溯到 1689 年，当时瑞典国王查尔斯十一世下令在 Husqvarna River 的河岸上开办一家火枪生产厂。选择这一地点非常合理，这是因为当时利用 Huskvarna River 中的水力来建立水力发电厂。在 300 多年的成长过程中，Husqvarna 工厂生产出了许多不同的产品，从木炉到现代化厨房用品、缝纫机、自行车、摩托车等等。1956 年，第一台电机驱动除草机问世，随后于 1959 年链锯诞生，这就是 Husqvarna 如今所从事的领域。

如今，Husqvarna 已经成为世界上领先的园林产品生产商之一，公司极为重视产品质量。公司的商业理念为：为园林与建筑行业开发、生产与提供电机驱动产品。此外，Husqvarna 的目标是在人体工程学、使用性、安全性及环保方面居于领先地位。这就是我们为这些领域中的产品开发许多不同功能的原因所在。

我们相信，在相当长一段时间之后，您会对我们产品的质量与性能高度满意。购买我们的任意产品，您都将随时获得专业的维修和保养帮助。如果出售本机的零售商不是我们的授权经销商，应咨询离您最近的保养厂的地址。

希望我们的产品让您称心如意并与您长期相伴。请将本操作手册视为重要文档。遵照其中的内容（使用、维修、维护等），机器的使用寿命及转让时的价值都将大大提高。出售本机时，请确保将操作手册转交买家。

非常感谢您使用 Husqvarna 产品。

连续开发产品是 Husqvarna AB 的政策，因此拥有保留修改产品设计和外观的权利，而无需事先通知。

构造图示说明

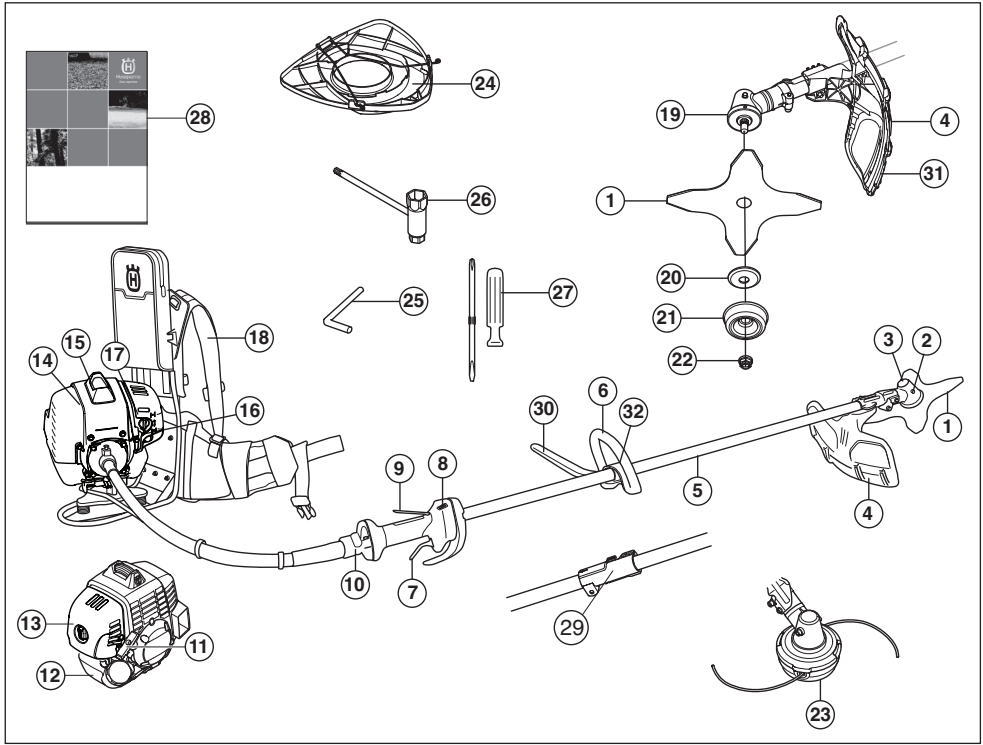

割灌机的构造图示说明

- | | |
|--------------|------------|
| 1 锯片 | 17 阻气门开关 |
| 2 斜齿轮润滑脂加注口盖 | 18 背带 |
| 3 斜齿轮 | 19 驱动盘 |
| 4 切割锯片防护罩 | 20 支撑凸缘 |
| 5 刀轴 | 21 支撑杯 |
| 6 环状柄 | 22 锁紧螺母 |
| 7 油门扳机 | 23 打草头 |
| 8 停止开关 | 24 运输护板 |
| 9 油门扳机锁 | 25 锁紧销 |
| 10 柔性驱动联轴节 | 26 套筒扳手 |
| 11 启动器把手 | 27 螺丝刀 |
| 12 燃油箱 | 28 操作手册 |
| 13 空气滤清器外壳 | 29 联轴节 |
| 14 气缸罩 | 30 J型手柄 |
| 15 火花塞帽和火花塞 | 31 防护罩附加部分 |
| 16 注油泵 | 32 手柄调整 |

一般安全须知

重要事项

重要事项！

本机仅设计于修剪草和清理草。

国家法规可能会对本机的使用进行管制。

可配合本引擎装置运转的唯一附件是我们在“技术参数”章节中推荐的切割锯片。

感到疲劳、曾经饮酒，或曾服用影响视力、判断力或协调能力的药物时，请勿操作本机。

请使用个人防护装备。请参阅“个人防护装备”一节的说明。

绝不能使用曾对原规格进行任何改动的机器。

禁止使用有故障的机器。按照本手册中的说明进行安全检查、维护和保养。部分维护和保养措施必须由受过培训并有相应资质的专家进行。请参阅《维护》篇中的说明。

启动前必须安装好所有盖子、防护罩和手柄。确保火花塞线帽和点火器导线未受损，以免出现电击风险。

在作业过程中，机器操作员必须确保 15 米范围内无任何人员或动物。当几个操作员在同一区域作业时，安全距离应至少达到 2 倍树高，不小于 15 米。

使用前应对机器进行全面检查。请参阅维护时间表。



警告！ 本机在操作期间会产生电磁场。电磁场在某些情况下会干扰有源或无源医疗植入体。为了减少严重或致命性伤害风险，我们建议使用医疗植入体的人员在操作本机之前事先咨询其医生及医疗植入体制造商。



警告！ 如果引擎在空间狭窄或通风不良的区域内运转，会导致相关人员窒息死亡或一氧化碳中毒身亡。



警告！ 切勿允许儿童使用或靠近机器。由于机器设有加载弹簧的停止开关，慢速在启动器把手上施力即可启动，有时甚至连儿童也有足够大的力气启动机器。这就有可能造成严重的人员伤亡。因此，机器在没有严密监督的情况下要拔掉火花塞帽子。

个人防护装备

重要事项！

清理锯、割灌机或打草机如果使用不当或疏忽会十分危险，可能导致操作员或周围人严重受伤甚至死亡。阅读并且理解本《操作手册》的内容极其重要。

使用本机时，一定要使用经过批准的个人防护装备。个人防护装备不能避免受伤，但当意外发生时，可降低伤害程度。选择防护装备时，请向经销商查询。



警告！ 戴有听觉保护设备时，请留意警告信号或呼喊声。一旦引擎停机，便取下听觉保护设备。

头盔

保护头盔（在有物体掉落风险的情况下）



听觉保护设备

佩带听觉保护设备，尽量降低噪音。



一般安全须知

眼部防护装备

始终佩戴经检验合格的眼部保护设备。如果使用面罩，必须同时配戴经检验合格的护目镜。在美国，经检验合格的护目镜必须符合 ANSI Z87.1 标准；在欧盟国家/地区，必须符合 EN 166。



手套

必要时应戴上手套，比如安装切割锯片时。



靴子

穿上坚固的防滑靴。



防护服

穿上用高强度纤维制成的衣物，避免穿着可能钩住小树枝和分支的衣物。务必穿上布料结实的长裤。不要佩戴首饰，不要穿短裤、凉鞋或者赤脚。将头发固定在肩部以上。

急救箱

附近应有急救箱。



机器安全设备

本节介绍机器的安全装备及其用途，并说明如何进行检查和维修，以确保机器正常运转。请参阅《构造图示说明》部分，可找到此种安全设备的正确位置。

如果机器维护不当或由非专业人士进行保养和/或维修，机器的使用寿命会缩短，发生意外的风险会增加。欲知更多详情，请与最近的保养厂联络。

重要事项！本机的保养和维修必须经过专门培训。对于本机的安全设备来说尤其如此。如果在检修过程中出现下述的故障，应与保养厂联络。如果您购买我们的产品，我们承诺提供专业的修理和保养。如果出售本机的零售商不是保养商，应向他咨询离您最近的保养厂的地址。



警告！不得使用安全设备存在故障的机器。机器的安全设备必须按照本节说明进行检查和维护。如果您的机器未通过这些检查中的任何一项，请联系您的保养厂对其进行维修。

油门扳机锁

油门锁设计用来预防油门控制意外启动操作。当您按住锁 (A) 时 (即抓住把手时)，油门控制装置 (B) 将被打开。当您松开把手时，油门控制装置与油门锁均返回至原始位置。这一动作由两个独立的回位弹簧控制。这种布局意味着油门控制装置自动锁定在怠速设定上。

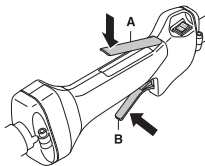

确保在油门锁松开时油门控制锁紧在怠速位置。

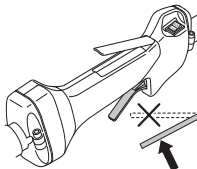

按下油门锁，并确保松开手后它返回原位。

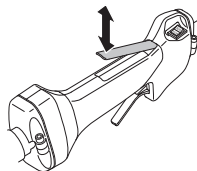

一般安全须知

检查油门开关和油门锁是否活动自如，复位弹簧是否运行正常。

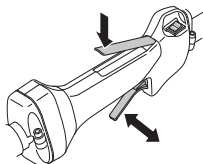

请参阅“启动”一节的说明。启动机器，全开油门。松开油门，检查切割锯片是否停止并保持不动。如果油门处于怠速位置而切割锯片仍然旋转，则要检查化油器的怠速设定。请参阅《维护》篇的说明。

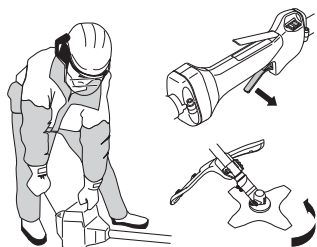

停止开关

使用停止开关关闭引擎。

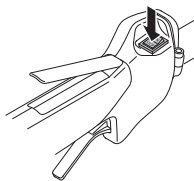

启动引擎，确保引擎在停止开关移到停止位置时停下来。

切割锯片防护罩

本防护罩旨在防止松散物体被抛向操作员。防护罩也可以防止操作员意外接触切割锯片。

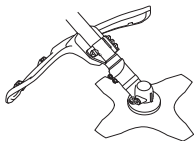

检查并确保防护罩没有损坏或裂痕。如果防护罩受到碰撞或有裂痕，请予以更换。

务必使用针对所用切割锯片推荐的防护罩。请参阅“技术参数”章节。



警告！严禁在未安装经检验合格的安全罩的情况下操作切割锯片。请参阅“技术参数”章节。安装不当规格或破损的安全罩会导致严重的人身伤害。

减振系统



本机配备有减振系统，用于尽量减少振动，并使操作更简单。

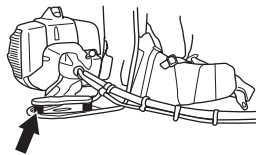

使用未正确缠绕的打草绳或使用钝的或不正确的切割锯片（关于错误类型或不正确的修整，请参阅“安装锯片”一节的说明）会增加振动水平。

本机的减振系统能降低引擎装置/切割设备以及机器把手之间的振动传递。

定期检查减振装置是否出现裂纹或变形。检查确保减震垫无损坏且安装牢固。



警告！血液循环不佳的人受到过度振动时，可能会导致循环系统或神经伤害。如果您因过度振动而引起以下症状，请自行就医。例如：麻痹、感觉麻木、发痒、刺痛、痛楚、体力缺乏、肤色或身体状况发生变化。这些症状通常出现在手指、双手或手腕上。低温情况下，这种危险会增加。

消音器

消音器设计用于最大程度地降低噪音并将引擎的废气导离操作人员。

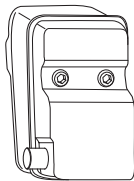

对于消音器，一定要按照说明进行检查、维修及保养。
切勿使用消音器出现故障的机器。

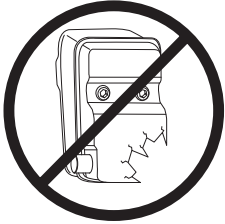

定期检查消音器是否牢固安装在机器上。

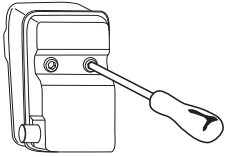

警告！消音器内含可致癌的化学物质。消音器出现故障时，务必避免接触这些物质。



警告！切记：引擎的废气很热，并可能带有火花，从而引发火灾。切勿在室内或易燃材料附近操作本机！

锁紧螺母

锁紧螺母用于固定某些类型的切割锯片。



安装时，按照与切割锯片转向相反的方向紧固螺母。要卸下螺母，请按照与切割锯片转向相同的方向松开螺母。
(小心！螺母具有左旋螺纹。) 用套筒扳手紧固螺母。

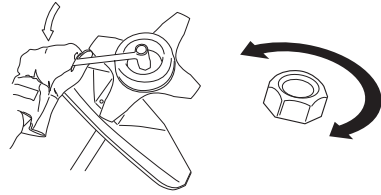

锁紧螺母内的尼龙衬垫不得磨损到您可以用手转动螺母的程度。衬垫应至少提供 1.5 Nm 的阻力。螺母安装约 10 次后应进行更换。

背带

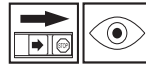

检查并确保背带未受损。

在紧急情况下，按照以下方法将自己与机器和背带脱离。

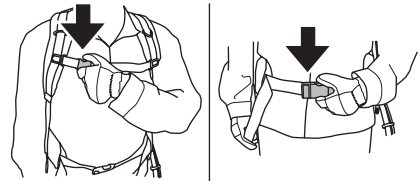

切割设备

本节介绍选择与维修您切割设备的方法，从而：

- 降低甩刀的风险。
- 获取最佳切割性能。
- 延长切割设备的使用寿命。

重要事项！

只能安装我们推荐的防护罩来使用切割锯片！请参阅“技术参数”章节。

请参阅切割锯片的说明以检查是否以正确方式安装打草绳以及打草绳直径是否正确。

确保正确打磨锯片齿！按照我们的建议操作。另请参阅锯片包装上的说明。

一般安全须知



警告！在对切割锯片执行任何操作之前，务必先停止运行发动机。即使释放了油门的情况下也会继续转动。开始对锯片进行操作之前，确保切割锯片完全停止，并断开火花塞帽。



警告！使用不正确的切割锯片或不正确打磨的锯片会增加发生甩刀的风险。

切割设备

打草刀片和割草刀适合用于切割杂草。

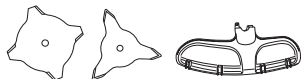

打草头适合用于修剪草坪。



一般规则



只能安装我们推荐的防护罩来使用切割锯片！请参阅“技术参数”章节。

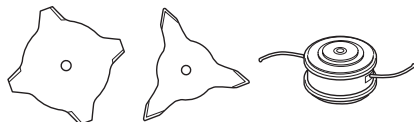

确保正确打磨锯片齿！请按照我们的说明使用推荐的扁锉规范。不正确打磨或损坏的锯片会增加发生意外的风险。

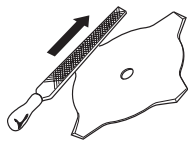

检查切割锯片是否损坏或有裂痕。应始终更换损坏的切割锯片。

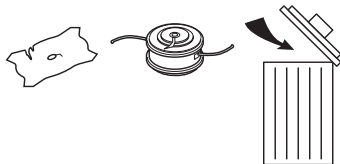

打磨割草刀和打草刀片



- 请参阅切割锯片包装以了解正确的打磨说明。使用单纹扁锉打磨锯片和刀片。
- 均匀地打磨所有刀刃以保持锯片的均衡。

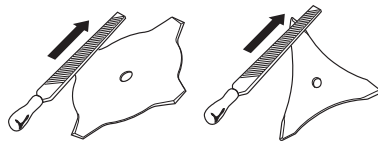

警告！务必丢弃因任何其他方式而弯曲、扭曲、破裂、破损或损坏的锯片。切勿尝试将扭曲的锯片拉直以便重复使用。只能使用规定类型的原装锯片。

打草头

重要事项！

务必确保将打草绳紧密且均匀地缠绕在离合杯上，否则机器会产生有害的振动。

- 只能使用推荐的打草头和打草绳。这些部件均经过制造商测试，适合在特定引擎尺寸条件下操作。在使用全自动打草头时，这一点特别重要。只能使用推荐的切割锯片。请参阅“技术参数”章节。



- 较小的机器通常要求使用小打草头，反之亦然。这是因为在使用打草绳进行清理时，引擎必须从打草头中径向抛出打草绳并克服所清理的草的阻力。
- 打草绳的长度也很重要。相同直径下，较长的打草绳比较短的打草绳需要更大的引擎功率。
- 请确保打草机防护罩上的切割齿完好无损。这用于按照正确的长度切割打草绳。
- 为提高打草绳的使用寿命，可在使用前将其在水中浸泡几天。这将使打草绳更坚韧，从而使用寿命更长。

组装

安装柔性驱动轴



- 将联轴节处的两颗螺钉拧松。

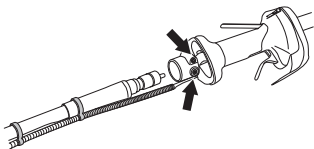

- 将柔性轴塞入卷缆柱的环，然后安装在联轴节上。一边转一边推，以确保柔性轴正确接合。
- 将两个螺钉紧固。
- 将驱动轴套装入离合器罩，以使固定孔位于离合器罩上锁紧钮的正下方。

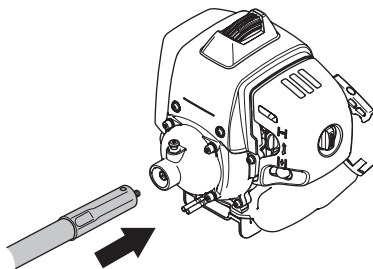

- 一边转一边推，以确保柔性轴正确接合。
- 确保锁紧销返回其原始位置，以使驱动轴套无法脱离离合器外壳。

连接油门电缆和停止开关导线



- 将卷缆柱 (A) 中的油门导线和引擎 (B) 的油门导线放入塑料套管中，如图所示。

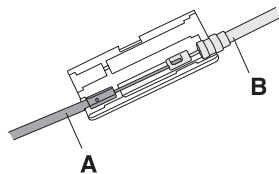

- 封闭塑料套管。

- 将停止开关导线插入引擎的匹配连接器。请注意，导线极性并不重要。

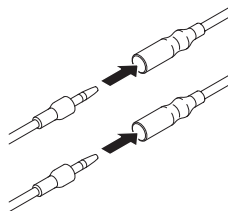

安装 J 型手柄



- 将环状柄定位在轴上。请注意，必须将环状柄安装在轴上箭头下方。

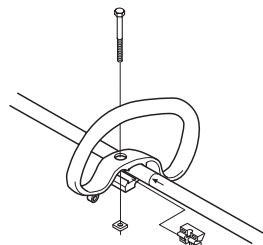

- 将垫片塞入环状柄的槽中。
- 安装螺母和螺钉。不要过紧。
- 使用 3 颗螺钉将 J 型手柄安装在环状柄上，如图所示。

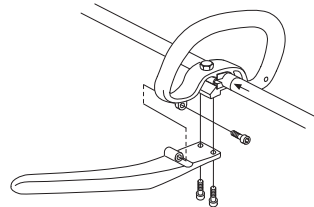

安装

- 现在，调节打草机以获得舒适的作业位置。紧固螺栓/旋钮。

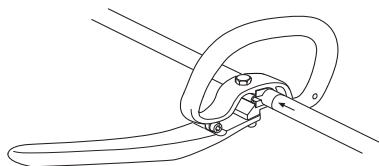

警告！安装J型手柄后，只能使用打草刀片/割草机或打草头/塑料刀片。安装J型手柄后，绝对不能使用锯片。

安装刀片和打草头



警告！安装切割锯片时，要将驱动盘/支撑凸缘上的凸起部分与切割锯片的中心孔正确接合，这一点极其重要。如果切割锯片安装不当，会导致严重的和/或致命的人身伤害。

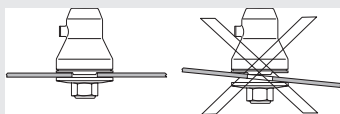

警告！严禁在未安装经检验合格的安全罩的情况下操作切割锯片。请参阅“技术参数”章节。安装不恰当规格或破损的安全罩会导致严重的人身伤害。

重要事项！使用锯片或打草刀片时，机器必须配备适当的把手、锯片防护罩和背带。

安装防护罩附加部分



小心！使用打草头/塑料刀片和组合防护罩时，应始终安装防护罩附加部分。使用打草刀片和组合防护罩时，应始终卸下防护罩附加部分。

将锯片防护罩/组合防护罩(A)挂在轴的接头上，然后用螺栓固定。

将防护罩附加部分导杆穿入组合防护罩的槽中。然后，将防护罩附加部分用快速紧固件卡入防护罩上的安装位置。

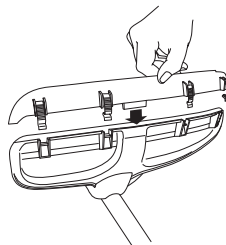

使用螺丝刀即可轻松拆卸防护罩附加部分，请参阅插图。

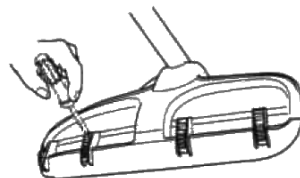

安装锯片防护罩、打草刀片和割草机



- 将锯片防护罩/组合防护罩(A)挂在轴的接头上，然后用螺栓(L)固定。使用推荐的锯片防护罩。参见“技术参数”一节。小心！确保卸下防护罩附加部分。

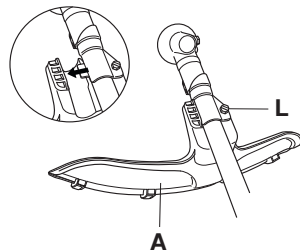

- 将驱动盘(B)安装在输出轴上。
- 转动输出轴，直至驱动盘的一个孔与齿轮箱中的相应孔对准。
- 将锁紧销(C)插入孔中以将轴锁定。
- 将锯片(D)、支撑杯(E)和支撑凸缘(F)置于输出轴上。

安装

- 安装螺母 (G)。必须将螺母紧固至 35-50 Nm (3.5-5 kpm) 的扭矩。使用工具箱中的套筒扳手。握住套筒扳手的轴，尽可能靠近锯片防护罩。要紧固螺母，请按照与旋转方向相反的方向转动套筒扳手（小心！是左旋螺纹）。

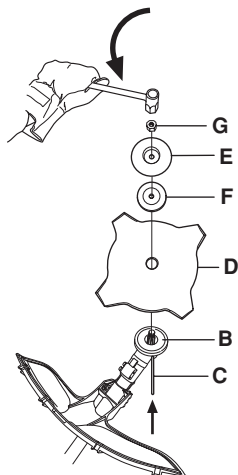

安装打草机防护罩和打草头



- 安装适用于打草头的正确打草机防护罩 (A)。小心！确保安装防护罩附加部分。

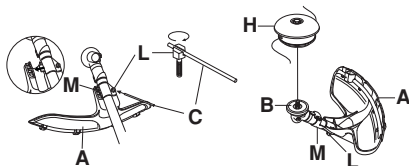

- 将打草机防护罩/组合防护罩 (A) 挂在轴的接头上，然后用螺栓 (L) 固定。
- 将驱动盘 (B) 安装在输出轴上。
- 转动输出轴，直至驱动盘的一个孔与齿轮箱中的相应孔对准。
- 将锁紧销 (C) 插入孔中以将轴锁定。
- 按照与旋转方向相反的方向拧紧打草头/塑料刀片 (H) 上的螺钉。

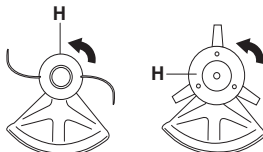

- 拆卸时，请按照与说明相反的顺序进行操作。

安装运输防护罩



- 将锯片插入运输防护罩 (A)。
- 将两个紧固件 (B) 扣入槽 (C) 中以固定运输防护罩。

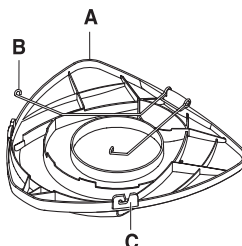

调整背带和割灌机



调整背板高度

- 将固定背板的两个紧固件拧松。

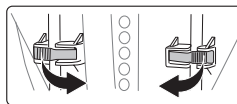

- 将背板从框架的一侧松开。

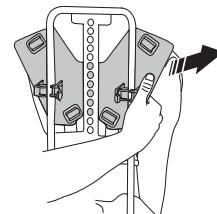

安装

- 将背板移至所需的高度，然后将其紧固。确保锁紧销与框架的一个孔对准，请参阅图片。

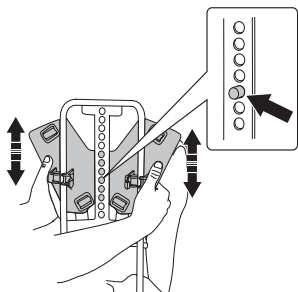

调整背带

- 安装背带。
- 束紧腰带，使其稳固。



- 束紧胸带。



- 如果需要，可垂直调整胸带，使其稳固。

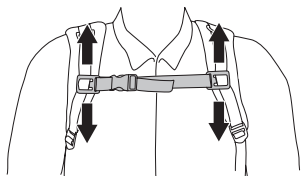

- 调整肩带，以使负载均匀地分配在肩部。



- 松开或束紧腰带，以使约 70% 的负载分配在腰部，30% 的负载分配在肩部。

拆装两件式轴

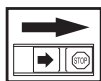

组装

- 逆时针转动旋钮以松开联轴节。
- 将附件 (A) 的凸舌与联轴节 (B) 的箭头对准。

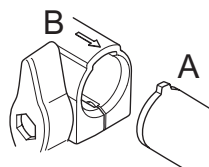

- 将附件推入联轴节，直至附件扣入到位。

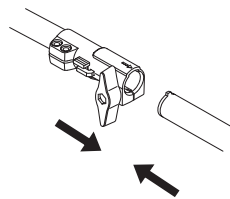

- 使用装置之前，先紧固旋钮。

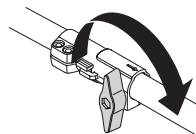

组装

拆卸

- 转动旋钮（至少 3 次）以松开联轴节。

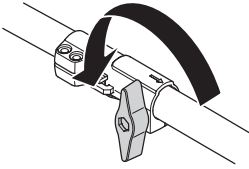

- 按住按钮 (C)。牢固握住引擎端，将附件从联轴节中直接拉出。

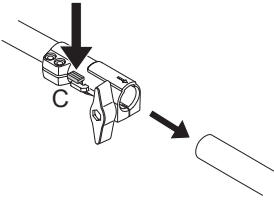

燃油处理

燃油安全须知

在下列情况下，切勿启动机器：

- 1 如果将燃油溅在机器上。先将溅出的燃油擦掉，然后让剩余的燃油蒸发掉。
- 2 如果燃油溅在自己身上或衣服上，须先换掉衣服。清洗接触到燃油的身体部位。使用肥皂和水进行清洗。
- 3 发生燃油泄漏情况。经常检查油箱盖和油管是否发生泄漏。

运输及存放

- 小心储存与运输机器及燃油，以免出现漏油或油气接触火花或明火的风险，比如来自电动机械、电机、继电器/电源开关或锅炉的火花或明火。
- 存放和运输燃油时，务必使用经过批准的专用容器。
- 长时间存放本机时，必须清空燃油箱。请咨询当地加油站如何处理剩余的燃油。
- 在长时间存放之前，确保清洁机器并且进行全面保养。
- 运输或存放机器时，务必安装切割锯片的运输防护罩。
- 运输期间将机器固定好。



警告！处理燃油时请小心。谨记失火、爆炸及误吸油气的危险。

燃油

小心！本机配有一个二冲程引擎，必须始终使用汽油与二冲程机油混合的燃油运行。注意准确测定要混合的油量，以确保正确混合。混合少量燃油时，即使小误差也会严重影响混合比。



警告！燃油和油气都是高度易燃物，一旦吸入或与皮肤接触，会造成严重的人身伤害。为此需要小心处理燃油，并确保空气流通。

汽油



小心！务必使用优质汽油/机油混合物（辛烷值（RON）至少为 90）。如果您的机器装有催化转换器（请参阅“技术参数”章节），请务必使用优质的无铅汽油/机油混合物。含铅汽油会损坏催化转换器。

如果可以的话，请使用低排放汽油，也叫烷基化汽油。

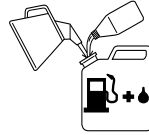

可使用乙醇混合燃油 E10（乙醇混合浓度最高 10%）。使用高于 E10 的乙醇混合燃油将产生贫油运行条件，从而对引擎造成损害。

- 最低建议辛烷值是 90 (RON)。如果您使用的辛烷标号低于 90，会导致出现爆震现象。这会导致引擎过热，令引擎严重受损。
- 连续高转速作业时，建议提高辛烷值。

二冲程机油

- 为获得最佳的效果和性能，最好使用 HUSQVARNA 为风冷式二冲程引擎专门开发的二冲程机油。
- 千万不可使用水冷式引擎专用的二冲程机油，即所谓的舷外机油（TCW 级）。
- 千万不可使用四冲程引擎专用的机油。
- 机油质量差和/或机油/燃油比过高会影响功能和缩短催化转换器的使用寿命。
- 混合比
和 HUSQVARNA 二冲程机油的混合比为 1:50 (2%)
和油品等级 JASO FB 或 ISO EGB 配制的风冷式二冲程机油的混合比为 1:33 (3%)。

汽油，公升	二冲程机油，公升	
	2% (1:50)	3% (1:33)
5	0.10	0.15
10	0.20	0.30
15	0.30	0.45
20	0.40	0.60

混合

- 请在干净的燃油专用容器内混合汽油与机油。
- 务必首先加入一半汽油。然后加入全部的机油。混合（摇匀）混合液。最后再加入另一半汽油。

燃油处理

- 加入机器的燃油箱之前，务必充分混合（摇匀）燃油混合液。

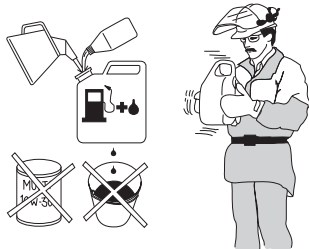

- 一次混合的油量不要超过一个月的用量。
- 如果机器一段时间不使用，应倒光油箱内的油，并清理干净。



警告！使用过程中及使用完后催化转换器消音器会很烫。怠速时同样如此。谨防火灾，尤其是在可燃物质和/或蒸汽附近作业时。

加燃油



警告！采取下列注意事项可以减少火患的发生：

不要吸烟或者把热烫的物体放在燃油旁边。

加油前先关掉引擎。

加油前务必关闭引擎，并让它冷却几分钟。

加油时，请慢慢打开油箱盖，以便缓慢释放过高的压力。

加油之后小心拧紧燃油箱盖。

务必将机器移离加油区和加油站之后才可启动。

- 必须使用带防溢漏阀的油罐。
- 将油箱盖四周清理干净。油箱上的污物会导致运行故障。

- 先将油罐摇匀，充分混合燃油后，再加入油箱。

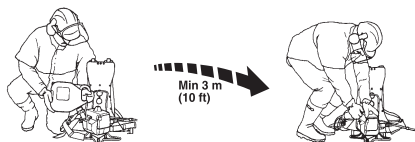

启动与停止

启动前检查



- 切勿在未安装防护罩或防护罩有缺陷的情况下使用机器。
- 启动机器前，必须正确安装好所有的盖，并且不得有损坏。
- 检查锯片以确保锯齿底部或中心孔处未出现裂纹。裂纹形成的最常见原因是：在打磨时齿的底部形成了锐角或使用的锯片齿不锋利。如果发现锯片有裂纹，请将其丢弃。

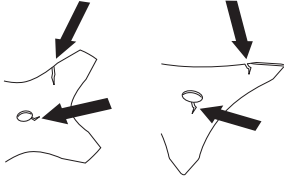

- 检查并确保支撑凸缘没有由于疲劳或过度拧紧而出现裂纹。如果发现支撑凸缘有裂纹，请将其丢弃。

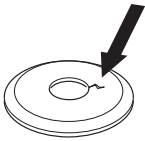

- 确保锁紧螺母未失去卡紧力。锁紧螺母应至少具有 1.5 Nm 的锁紧力。锁紧螺母的紧固扭矩应达到 35-50 Nm。



- 检查锯片防护罩是否损坏或有裂痕。如果锯片防护罩受到碰撞或有裂痕，请予以更换。

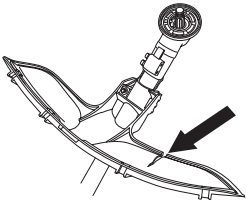

- 检查并确保打草头和打草机防护罩没有损坏或裂痕。打草头或打草机防护罩受到撞击或出现裂缝时，请进行更换。

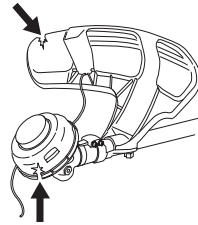

启动与停止



警告！ 机器启动之前一定要安装好离合器罩和轴，否则离合器会松动，会造成人身伤害。

务必将机器移离加油区和加油站之后才可启动。将机器停放在平整表面上。确保切割锯片不会与任何物体接触。

确定没有非工作人员在现场。否则会造成严重的人身伤害。安全距离为 15 米。

启动



点火装置： 将停止开关设置到开始位置。

启动注油器： 反复挤压注油泵直至燃油开始注入球囊。不必将球囊装满。

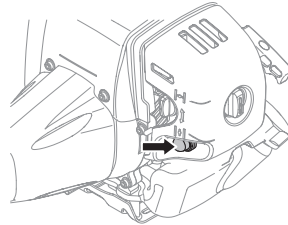

启动与停止

阻气门：将风门设在阻风位置。

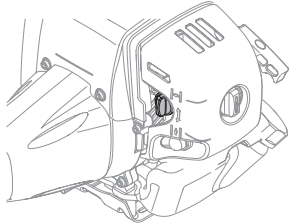

警告！在阻气门处于阻气门位置或启动油门位置的情况下，当引擎启动时，切割锯片将立即开始旋转。

用左手将机器按在地上（小心！不要用脚！）用右手抓住启动器把手，慢慢地向外拉启动绳，直到感觉到有阻力（止轮具抓紧），然后快速用力地拉。千万不可将启动器拉绳绕在手上。

反复拉动拉绳，直到引擎启动。引擎启动后，使阻气门返回运行位置，全开油门；油门将会自动脱离启动设置。

小心！不要将启动器的拉绳拉到底，也不要完全拉出的位置放开启动器把手。这样做会损坏机器。

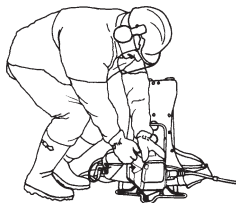

小心！不要让身体的任何部分进入标记区。如果火花塞帽已经损坏，接触会烧伤皮肤或发生电击。请务必戴上手套。不要使用火花塞帽破损的机器。

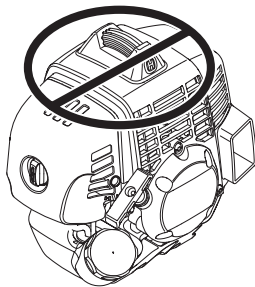

停止



关闭点火器，停止引擎运行。

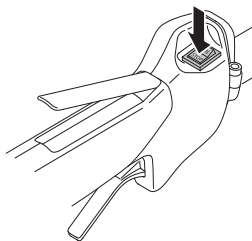

操作方法

一般工作须知

重要事项！

本节介绍使用割灌机和打草机的基本安全须知。

当您遇到任何情况，不知如何继续时，请咨询专家。与您的经销商或保养厂联系。

避免任何超出您能力范围的使用。

在使用之前，您必须了解林地清理、草坪清理和草坪修剪之间的差异。

基本安全守则



1 环顾四周：

- 确定没有人、动物或其他物品会影响到您操控动力切割机。
 - 要确保人员、动物等不会接触切割锯片或切割锯片抛出的松散物体。
 - 小心！如果发生事故时无法求救，请勿使用本机。
- 2 检查作业区。移除所有可能被抛出或缠绕切割锯片的松散物体，如石块、碎玻璃、钉子、钢丝、线绳等。
- 3 避免在不良的天气情况下使用本机，例如浓雾、大雨、强风或是严寒等。在天气不良的情况下工作容易让人疲倦，更可能造成危险状况，例如容易滑倒的地面。
- 4 确保您可以安全地移动与站立。检查您的周围区域是否存在障碍物（树根、岩石、树枝、沟渠等），以免您突然移动。在倾斜地面上工作时，要特别小心。



- 5 操作时，务必用肩带携带本背包式割灌机。
- 6 请勿距离过远。请始终维持适当的位置和平衡。

- 7 务必用双手扶住机器。使您的身体各部位远离高温表面。使身体各部位远离旋转的切割锯片。
- 8 务必在腰部以下操作切割锯片。
- 9 关闭引擎后再移动到其它区域。无论距离多远，在搬运或运输设备之前都应安装运输防护罩。
- 10 切勿在引擎运转的情况下放下下机器，除非是放在您可以清楚看到的位置。



警告！ 机器操作员或其他任何人均不得在引擎运转或切割设备旋转时尝试清除落料，否则可能会导致严重的人身伤害。

先让引擎和切割设备停止运行，然后再清除缠绕在锯片轴上的材料，否则会有受伤的危险。使用过程中，斜齿轮可能会发热，并在之后一段时间仍有余热。触摸可能会烧伤。



警告！ 注意抛掷物。始终佩戴经检验合格的眼部保护设备。切勿将切割锯片防护罩倾斜。石头、垃圾等会抛入眼中，导致失明或严重伤害。

未经授权的人员不得靠近。保持儿童、动物、旁观者和帮忙者在 15 米安全区以外。如有人靠近，立即停止机器。转动机器之前务必先查看身后，确保安全区内无人。

基本工作技巧

每个工作冲程之后请务必将引擎速度降至空转速度。发动机空载且油门全开地长时间运转会严重损坏发动机。



警告！ 有时，树枝或草会卡在防护罩和切割锯片之间。在清洁之前务必停止引擎运行。

操作方法



警告！装有锯片或打草刀片的机器在锯片或刀片接触固定物体时会猛地甩向一侧。这被称为甩刀。甩刀的反冲力很大，能将机器和/或操作员推向任何方向，并有可能失去对机器的控制。如果机器遇到阻碍、停顿或束缚，则可能在无警告的情况下发生甩刀。在难以看清切割材料的区域更容易发生甩刀。

避免将锯片置于12点钟和3点钟位置之间的区域进行切割。由于锯片快速旋转，如果您试图将锯片置于该区域切割厚茎，可能会发生甩刀。

使用打草刀片清理草坪



- 打草刀片和割草刀不得用于切割木质茎。
- 打草刀片适用于清理各类高草或杂草。
- 通过侧向摆动方式进行割草，其中从右向左移动是清理行程，从左向右移动是回程。使用锯片的左侧（8点钟到12点钟位置之间）进行切割。

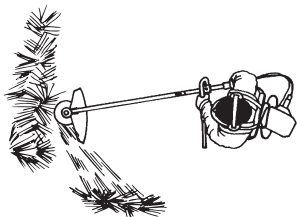

- 清理草坪时，如果锯片向左倾斜，则草会聚拢成一行，用耙子等很容易收集。
- 尝试有节奏地作业。双脚分开站稳。回程后向前移动，然后重新站稳。
- 将支撑杯稍稍靠在地面上。它用于防止锯片撞击地面。
- 按照这些说明进行操作以降低材料缠绕锯片的风险：
 - 务必在全油门状态下作业。
 - 避免在回程中切割之前切割的材料。
- 停止引擎运行，解开背带并将机器放在地上，然后再收集切割的材料。

使用打草头修剪草坪



修剪

- 握住打草头，使其与地面呈一定角度且恰好离地。这是打草绳作业的末端。让打草绳以自己的节奏作业。切勿将打草绳按进要切割的区域。



- 打草绳可以轻松清除墙、栅栏、树木及界线处的草和杂草。但是，它也可能损坏树木和灌木上易受影响的树皮，并损坏栅栏柱。
- 将打草绳缩短至10-12 cm并降低引擎转速可降低植物受损的风险。

清理

- 清理技巧可清除所有多余的草木。使打草头恰好离地并将其倾斜。使用打草绳的末端扫过树木、柱子、雕像和类似物体周围的地面。小心！该技巧会增加打草绳的磨损。



- 与接触树木和木栅栏时相比，打草绳在石块、砖块、混凝土、金属栅栏等处作业时磨损得更快，必须更经常地向前馈送。
- 修剪和清理时，油门应低于全油门（80%）以便延长打草绳的使用寿命，降低打草头的磨损。

切割

- 打草机非常适合切割使用普通除草机难以切割的草。切割时，将打草绳与地面保持平行。避免将打草头压在地面上，否则可能会破坏草坪，损坏刀具。

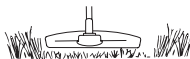

- 在正常切割时，不要让打草头持续接触地面。此类持续接触可能会导致打草头损坏和磨损。

操作方法

清除

- 旋转打草绳的扇形效应可用于快速轻松地清除杂草。使打草绳处于要清除的区域上方并与之保持平行，然后将工具从一边移至另一边。

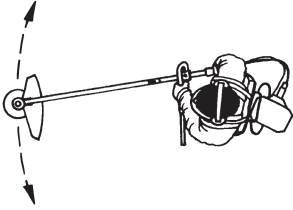

- 切割和清除时，应使用全开油门以获得最佳效果。

维护

化油器

调整怠速 (T)

检查空气滤清器是否洁净。怠速正确时，切割锯片不应旋转。如果需要调整，请拧紧（顺时针转动）怠速调整螺钉 T，使引擎运转，直至切割锯片开始旋转。松开（逆时针转动）螺钉，直至切割锯片停止旋转。当引擎在各个位置均运转顺畅时，表示怠速设置正确，并且怠速与切割锯片开始旋转时的转速有明显差异。

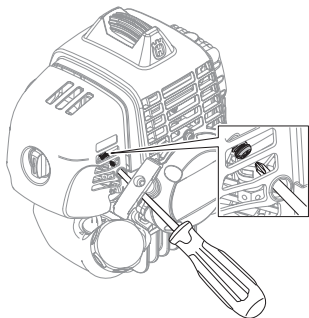

警告！ 如果无法调整怠速转速以至工作装置停止转动，请联络代理商/维修店。在还未正确调整或修理前，请勿使用机器。

冷却系统

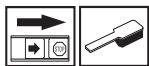

为了尽量保持较低的操作温度，本机器配备了冷却系统。

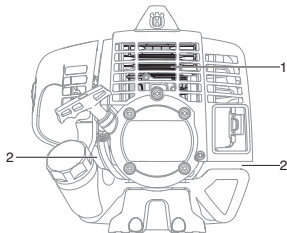

冷却系统由以下部分组成：

- 1 气缸上的散热片。
- 2 进气口。

每周一次用刷子清洗冷却系统，在恶劣的环境下更应常清洗。脏污或堵塞的冷却系统会引起引擎过热，导致气缸及活塞损坏。

空气滤清器

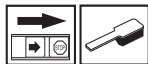

必须定期清洁空气滤清器，以清除泥土和灰尘，避免发生下列情况：

- 化油器故障。
- 启动问题。
- 引擎功率损耗。
- 引擎零件发生不必要磨损。
- 过度耗油。

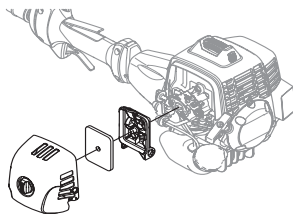

每 25 小时清洁一次滤清器，或者如果在灰尘异常多的环境下，则要增加清洁次数。

清洁空气滤清器

打开空气滤清器外壳，取出滤清器。用压缩空气吹净。

滤清器经过长期使用之后，无法彻底清洁。因此，所有的空气滤清器都应定期更换新的。损坏的空气滤清器一定要换新。

燃油滤清器

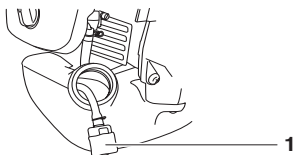

1 燃油滤清器

当引擎缺少燃油供给时，检查油箱盖和燃油滤清器是否堵塞。

维护

两件式轴

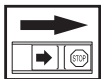

应当用润滑脂对下轴中的驱动轴端每 30 小时润滑一次。在两件式轴机型上，如果不定期润滑，则可能会存在驱动轴端（花键配合联轴节）卡住的风险。

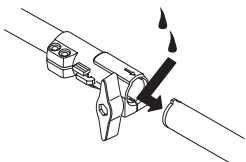

斜齿轮



斜齿轮在出厂时已经注入了适量润滑脂。但是，在使用机器之前应检查斜齿轮中的润滑脂是否已加注到四分之三满的位置。使用 HUSQVARNA 专用润滑脂。

斜齿轮中的润滑脂通常不需要更换，但维修情况除外。

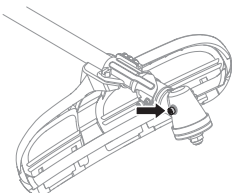

火花塞



火花塞的状况会受下列的因素影响：

- 化油器调节不正确。
- 燃油混合不正确（机油太多或种类不对）。
- 空气滤清器变脏。

这些因素会导致异物堆积在火花塞电极上，从而造成操作问题及启动困难。

如果机器动力不足、不易启动或是怠速运转情况差，首先检查火花塞，然后再采取其他措施。如果火花塞很脏，清洁并检查跳火间距是否为 0.9-1.0 毫米。经过大约一个月的使用后，或在此前有需要时，应该更换火花塞。

0,9 - 1,0 mm

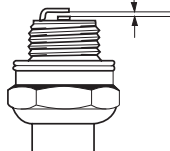

小心！务必使用推荐的火花塞类型！不适合的火花塞会损坏活塞/气缸。检查并确定火花塞安装有抑制器。

驱动轴



使用 Husqvarna 驱动轴润滑脂润滑柔性驱动轴。柔性驱动轴必须至少每 6 个月润滑一次。

- 提起离合器罩中固定驱动轴套的锁紧钮。

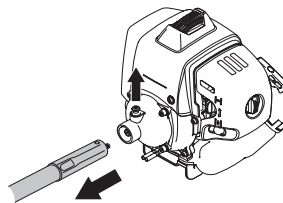

- 将驱动轴套从离合器罩中拉出。
- 从轴套中取出驱动轴：摇晃出来或用钳子拉出。

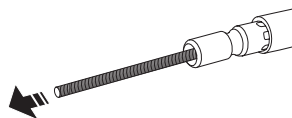

- 沿整个轴涂抹润滑脂。用刷子或布涂抹。

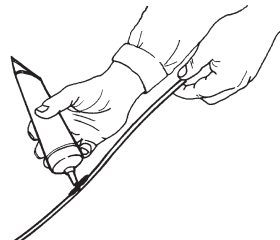

维护

- 将驱动轴塞回到轴套。一边转一边推，以确保柔性轴正确接合。

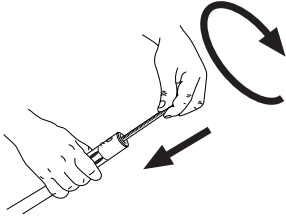

- 将驱动轴正确装入轴套时，轴端应伸出轴套边缘约 10 mm。

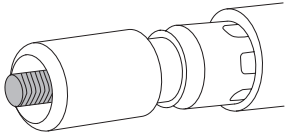

- 将驱动轴套装入离合器罩，以使固定孔位于离合器罩上锁紧钮的正下方。

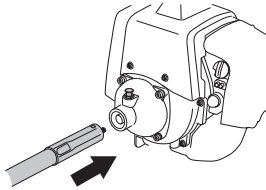

- 一边转一边推，以确保柔性轴正确接合。

维护

维护计划

以下是必须对本机进行的维修事项的列表。大多数的维护项目已在“维护”一节中进行说明。用户只能进行本《操作手册》中所述的保养和维修工作。其他的作业必须由授权的保养厂进行。

维护	日常维护	每周维护	每月维护
清洁机器的外部。	X		
检查并确保背带未受损。	X		
从安全角度出发，确保油门扳机锁和油门功能正常。	X		
检查手柄和把手是否均完好无损并正确固定。	X		
检查停止开关能否正常操作。	X		
检查并确保切割锯片在怠速状态下不转动。	X		
清洁空气滤清器。必要时换新。	X		
检查并确保防护罩没有损坏或裂痕。如果防护罩受到碰撞或有裂痕，请予以更换。	X		
检查锯片是否正确居中、锋利且未出现裂缝。锯片偏心可能会产生振动，导致机器损坏。	X		
检查并确保打草头没有损坏或裂痕。必要时更换打草头。	X		
检查切割设备的锁紧螺母是否正确紧固。	X		
检查锯片的运输防护罩是否完好无损且已正确固定。	X		
检查螺母和螺丝是否上紧。	X		
检查引擎、油箱与燃油管是否漏油。	X		
检查启动器及启动器绳索。		X	
检查确认防振元件未损坏。		X	
清洁火花塞外部。拔下火花塞，然后检查跳火间距。将跳火间距调整至 0.9-1.0 mm 或更换火花塞。检查并确定火花塞安装有抑制器。		X	
清洁机器的冷却系统。		X	
清洁化油器外部以及其周围区域。		X	
检查斜齿轮中的润滑脂是否已加注到四分之三满的位置。必要时使用专用润滑脂进行加注。		X	
检查燃油滤清器上是否有污物，油管是否有裂痕或其它破损现象。必要时换新。			X
检查所有的电缆及接头。			X
检查离合器、离合器弹簧及离合杯的磨损状况。必要时由授权的保养厂进行更换。			X
更换火花塞。检查并确定火花塞安装有抑制器。			X
使用 Husqvarna 驱动轴润滑脂润滑驱动轴。	每六个月润滑一次。		

技术参数

技术参数

543 RBS

引擎

气缸排量 (cm ³)	40.1
缸径 (mm)	40.5
冲程 (mm)	31.1
空转速度 (rpm)	3000
建议的最大转速 (rpm)	12000
输出轴速度 (rpm)	9600
最大引擎输出, 按照 ISO 8893, 单位为 kW/rpm	1,5/9000
催化转换器消音器	无

点火系统

火花塞	NGK CMR7H-10
跳火间距 (mm)	0.9-1.0

燃油和润滑系统

燃油箱容量 (L)	0.75
-----------	------

重量

不包括燃油、切割锯片和保护装置在内的重量, kg	9.3
--------------------------	-----

噪声级

(参阅注释 1)

操作人员耳旁的等效声压级根据 EN ISO 11806 和 ISO 22868 测量得出, 单位为 dB(A):	96
--	----

振动程度

(参阅注释 2)

手柄的振动水平 ($a_{hv,eq}$) 根据 EN ISO 11806 和 ISO 22867 测得, 单位为 m/s ²	4,0/2,7
--	---------

注释 1: 本机的等效声压级的报告数据中具有一个 1 dB (A) 的典型统计离差 (标准偏差)。

注释 2: 等效振级的报告数据中具有一个 1 m/s² 的典型统计离差 (标准偏差)。

经批准使用的附件	类型	切割锯片防护罩, 货号
打草刀片/割草机	Multi 300-3 (Ø 300 3 齿)	537 33 16-03
	Multi 255-3 (Ø 255 3 齿)	537 33 16-03
	Grass 275-4 (Ø 275 4 齿)	537 33 16-03
	Grass 255-4 (Ø 255 4 齿)	537 33 16-03
打草头	T35、T35x (Ø 2.4 - 3.0 mm 打草绳)	537 33 16-03
	T45x (Ø 2.7 - 3.3 mm 打草绳)	537 33 16-03
	T55x (Ø 2.7 - 3.3 mm 打草绳)	537 33 16-03
	F35 (Ø 2.0 - 3.5 mm 打草绳)	537 33 16-03
支撑杯	固定	-

建议将以下附件用于特定机型。

附件	货号	用途
配有 HA 850 驱动轴的绿篱机附件	967 02 67-01	543 RBK
割灌机锯片 (带 SA 850 轴)。	967 02 69-01	543 RBK
割灌机锯片 (带 GTA 850 轴)。	967 11 31-01	543 RBK

技术参数

欧盟一致性申明（仅适用于欧洲）

我们，**Husqvarna AB**, SE-561 82 Huskvarna, 瑞典, 电话: +46-36-146500, 谨此声明, 序列号自 2012 年 (年份同随后的序列号一起清楚地标注在标牌上) 起的割灌机 **Husqvarna 543 RBX**、**543 RBK** 符合以下欧盟指令:

- 2006 年 5 月 17 日“关于机械”的指令 **2006/42/EC**。

- 2004 年 12 月 15 日“关于电磁兼容性”的指令 **2004/108/EC**。

- 2000 年 5 月 8 日“关于噪音释放”的指令 **2000/14/EC**。符合性评估依据“附件 V”执行。有关噪音排放的信息, 请参阅“技术参数”章节。

适用标准如下:

EN ISO 12100:2010、**CISPR 12:2009**、**ISO 14982:1998**、**EN ISO 11806-1:2011**、**EN ISO 11806-2:2011**

SMP Svensk Maskinprovning AB (地址: 7035, SE-750 07 Uppsala, Sweden) 已代表 Husqvarna AB 进行了自愿性类型检验。

证书编号:

543 RBX、543 RBK - **SEC/12/2362**

Husqvarna 2012 年 12 月 21 日



Per Gustafsson, 开发经理 (Husqvarna AB 授权代表, 负责技术文档编制事务。)

KEY TO SYMBOLS

Symbols

WARNING! A clearing saw, brushcutter or trimmer can be dangerous if used incorrectly or carelessly, and can cause serious or fatal injury to the operator or others. It is extremely important that you read and understand the contents of this operator's manual.



Please read the operator's manual carefully and make sure you understand the instructions before using the machine.



Always wear:

- Wear a protective helmet where there is a risk of falling objects
- Approved hearing protection
- Approved eye protection



Max. speed of output shaft, rpm



This product is in accordance with applicable EC directives.



Watch out for thrown objects and ricochets.



The operator of the machine must ensure, while working, that no persons or animals come closer than 15 meters.



Machines fitted with saw blades or grass blades can be thrown violently to the side when the blade comes into contact with a fixed object. This is called blade thrust. The blade is capable of amputating an arm or leg. Always keep people and animals at least 15 meters from the machine.



Arrows which show limits for handle positioning.



Ignition; choke: Set the choke control in the choke position.



Air purge



Always wear approved protective gloves.



Wear sturdy, non-slip boots.



Only use non-metallic, flexible cutting attachments, i.e. trimmer heads with trimmer cord.



Noise emission to the environment according to the European Community's Directive. The machine's emission is specified in the Technical data chapter and on the label.



Keep all parts of your body away from hot surfaces.



Other symbols/decals on the machine refer to special certification requirements for certain markets.

Switch off the engine by moving the stop switch to the STOP position before carrying out any checks or maintenance.



Always wear approved protective gloves.



Regular cleaning is required.



Visual check.



CONTENTS

Contents

KEY TO SYMBOLS

Symbols 29

CONTENTS

Contents 30

Note the following before starting: 30

INTRODUCTION

Dear Customer, 31

WHAT IS WHAT?

What is what on the brush cutter? 32

GENERAL SAFETY PRECAUTIONS

Important 33

Personal protective equipment 33

Machine's safety equipment 34

Cutting equipment 36

ASSEMBLY

Fitting the flexible drive shaft 38

Connecting throttle cable and stop switch wires ... 38

Fitting the J-handle 38

Fitting blades and trimmer heads 39

Fitting the transport guard 40

Adjusting the harness and brush cutter 40

Assembling and dismantling the two-piece shaft .. 41

FUEL HANDLING

Fuel safety 43

Fuel 43

Fueling 44

STARTING AND STOPPING

Check before starting 45

Starting and stopping 45

WORKING TECHNIQUES

General working instructions 47

MAINTENANCE

Carburettor 50

Cooling system 50

Air filter 50

Fuel filter 50

Two-piece shaft 51

Bevel gear 51

Spark plug 51

Drive shaft 51

Maintenance schedule 53

TECHNICAL DATA

Technical data 54

EC Declaration of Conformity 55

Note the following before starting:

Please read the operator's manual carefully.



WARNING! Long-term exposure to noise can result in permanent hearing impairment. So always use approved hearing protection.



WARNING! Under no circumstances may the design of the machine be modified without the permission of the manufacturer. Always use original accessories. Non-authorized modifications and/or accessories can result in serious personal injury or the death of the operator or others.



WARNING! A clearing saw, brushcutter or trimmer can be dangerous if used incorrectly or carelessly, and can cause serious or fatal injury to the operator or others. It is extremely important that you read and understand the contents of this operator's manual.

INTRODUCTION

Dear Customer,

Congratulations on your choice to buy a Husqvarna product! Husqvarna is based on a tradition that dates back to 1689, when the Swedish King Karl XI ordered the construction of a factory on the banks of the Husqvarna River, for production of muskets. The location was logical, since water power was harnessed from the Huskvarna River to create the water-powered plant. During the more than 300 years in existence, the Husqvarna factory has produced a lot of different products, from wood stoves to modern kitchen appliances, sewing machines, bicycles, motorcycles etc. In 1956, the first motor driven lawn mowers appeared, followed by chain saws in 1959, and it is within this area Husqvarna is working today.

Today Husqvarna is one of the leading manufacturers in the world of forest and garden products, with quality as our highest priority. The business concept is to develop, manufacture and market motor-driven products for forestry and gardening, as well as for the building and construction industry. Husqvarna's aim is also to be at the front edge for ergonomics, usability, security and environmental protection. That is the reason why we have developed many different features to add to our products within these areas.

We are convinced that you will appreciate with great satisfaction the quality and performance of our product for a very long time to come. The purchase of one of our products gives you access to professional help with repairs and service whenever this may be necessary. If the retailer who sells your machine is not one of our authorised dealers, ask for the address of your nearest service workshop.

It is our wish that you will be satisfied with your product and that it will be your companion for a long time. Think of this operator's manual as a valuable document. By following its content (usage, service, maintenance, etc), the life span and the second-hand value of the machine can be extended. If you sell this machine, make sure that the operator's manual is passed on to the buyer.

Thank you for using a Husqvarna product.

Husqvarna AB has a policy of continuous product development and therefore reserves the right to modify the design and appearance of products without prior notice.

WHAT IS WHAT?

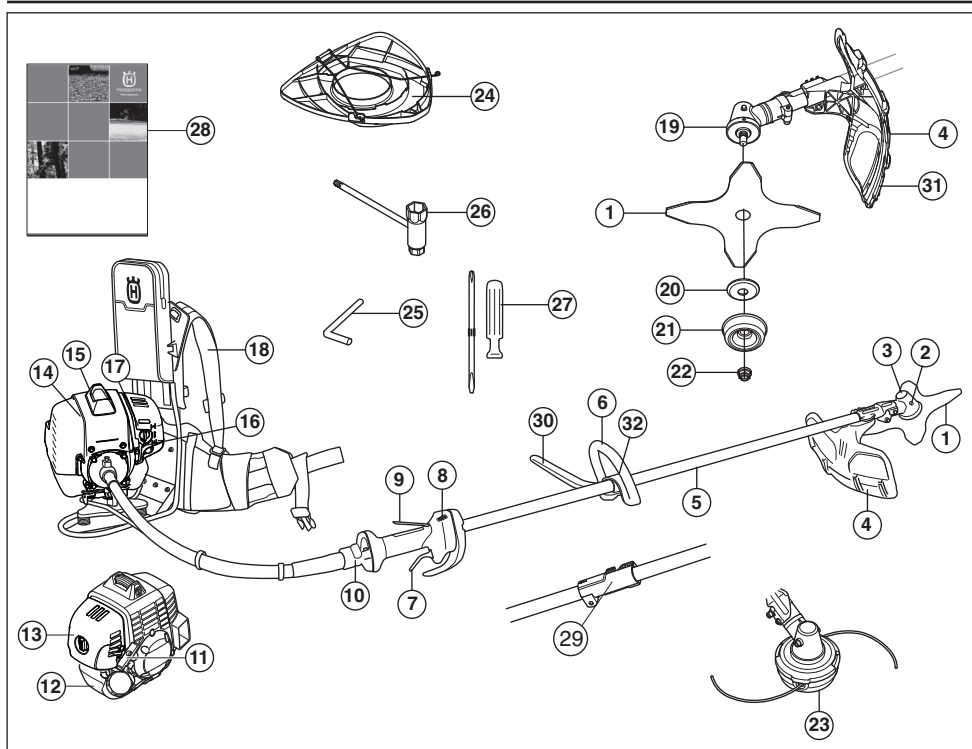

What is what on the brush cutter?

- | | |
|----------------------------------|----------------------|
| 1 Blade | 17 Choke control |
| 2 Grease filler cap, bevel gear | 18 Harness |
| 3 Bevel gear | 19 Drive disc |
| 4 Cutting attachment guard | 20 Support flange |
| 5 Shaft | 21 Support cup |
| 6 Loop handle | 22 Locking nut |
| 7 Throttle trigger | 23 Trimmer head |
| 8 Stop switch | 24 Transport guard |
| 9 Throttle trigger lockout | 25 Locking pin |
| 10 Flexible drive shaft coupling | 26 Socket spanner |
| 11 Starter handle | 27 Screwdriver |
| 12 Fuel tank | 28 Operator's manual |
| 13 Air filter cover | 29 Shaft coupling |
| 14 Cylinder cover | 30 J-handle |
| 15 Spark plug cap and spark plug | 31 Guard extension |
| 16 Air purge | 32 Handle adjustment |

GENERAL SAFETY PRECAUTIONS

Important

IMPORTANT!

The machine is only designed for grass trimming and grass clearing.

National regulation can restrict the use of the machine.

The only accessories you can operate with this engine unit are the cutting attachments we recommend in the chapter on Technical data.

Never use the machine if you are tired, if you have drunk alcohol, or if you are taking medication that could affect your vision, your judgement or your co-ordination.

Wear personal protective equipment. See instructions under the "Personal protective equipment" heading.

Never use a machine that has been modified in any way from its original specification.

Never use a machine that is faulty. Carry out the safety checks, maintenance and service instructions described in this manual. Some maintenance and service measures must be carried out by trained and qualified specialists. See instructions under the Maintenance heading.

All covers, guards and handles must be fitted before starting. Ensure that the spark plug cap and ignition lead are undamaged to avoid the risk of electric shock.

The machine operator must ensure that no people or animals come closer than 15 meters while working. When several operators are working in the same area the safety distance should be at least twice the tree height and no less than 15 meters.

Carry out an overall inspection of the machine before use. See the maintenance schedule.



WARNING! This machine produces an electromagnetic field during operation. This field may under some circumstances interfere with active or passive medical implants. To reduce the risk of serious or fatal injury, we recommend persons with medical implants to consult their physician and the medical implant manufacturer before operating this machine.



WARNING! Running an engine in a confined or badly ventilated area can result in death due to asphyxiation or carbon monoxide poisoning.



WARNING! Never allow children to use or be in the vicinity of the machine. As the machine is equipped with a spring-loaded stop switch and can be started by low speed and force on the starter handle, even small children under some circumstances can produce the force necessary to start the machine. This can mean a risk of serious personal injury. Therefore remove the spark plug cap when the machine is not under close supervision.

Personal protective equipment

IMPORTANT!

A clearing saw, brushcutter or trimmer can be dangerous if used incorrectly or carelessly, and can cause serious or fatal injury to the operator or others. It is extremely important that you read and understand the contents of this operator's manual.

You must use approved personal protective equipment whenever you use the machine. Personal protective equipment cannot eliminate the risk of injury but it will reduce the degree of injury if an accident does happen. Ask your dealer for help in choosing the right equipment.



WARNING! Listen out for warning signals or shouts when you are wearing hearing protection. Always remove your hearing protection as soon as the engine stops.

HELMET

Wear a protective helmet where there is a risk of falling objects



HEARING PROTECTION

Wear hearing protection that provides adequate noise reduction.



GENERAL SAFETY PRECAUTIONS

EYE PROTECTION

Always wear approved eye protection. If you use a visor then you must also wear approved protective goggles. Approved protective goggles must comply with the ANSI Z87.1 standard in the USA or EN 166 in EU countries.



GLOVES

Gloves should be worn when necessary, e.g. when fitting cutting attachments.



BOOTS

Wear sturdy, non-slip boots.



CLOTHING

Wear clothes made of a strong fabric and avoid loose clothing that can catch on twigs and branches. Always wear heavy, long pants. Do not wear jewellery, shorts sandals or go barefoot. Secure hair so it is above shoulder level.

FIRST AID KIT

Always have a first aid kit nearby.



Machine's safety equipment

This section describes the machine's safety equipment, its purpose, and how checks and maintenance should be carried out to ensure that it operates correctly. See the "What is what?" section to locate where this equipment is positioned on your machine.

The life span of the machine can be reduced and the risk of accidents can increase if machine maintenance is not carried out correctly and if service and/or repairs are not carried out professionally. If you need further information please contact your nearest service workshop.

IMPORTANT! All servicing and repair work on the machine requires special training. This is especially true of the machine's safety equipment. If your machine fails any of the checks described below you must contact your service agent. When you buy any of our products we guarantee the availability of professional repairs and service. If the retailer who sells your machine is not a servicing dealer, ask him for the address of your nearest service agent.



WARNING! Never use a machine with faulty safety equipment. The machine's safety equipment must be checked and maintained as described in this section. If your machine fails any of these checks contact your service agent to get it repaired.

Throttle trigger lockout

The throttle lockout is designed to prevent accidental operation of the throttle control. When you press the lock (A) (i.e. when you grasp the handle) it releases the throttle control (B). When you release the handle the throttle control and the throttle lockout both move back to their original positions. This movement is controlled by two independent return springs. This arrangement means that the throttle control is automatically locked at the idle setting.

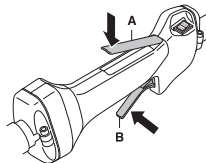

Make sure the throttle control is locked at the idle setting when the throttle lockout is released.

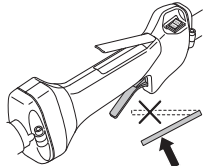

Press the throttle lockout and make sure it returns to its original position when you release it.

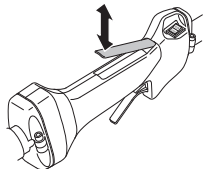

GENERAL SAFETY PRECAUTIONS

Check that the throttle trigger and throttle lockout move freely and that the return springs work properly.

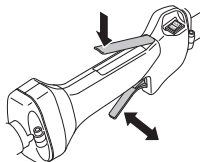

See instructions under the heading Start. Start the machine and apply full throttle. Release the throttle and check that the cutting attachment stops and remains at a standstill. If the cutting attachment rotates with the throttle in the idle position then the carburettor idle setting must be checked. See instructions under the heading Maintenance.

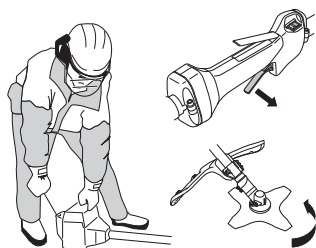

Stop switch

Use the stop switch to switch off the engine.

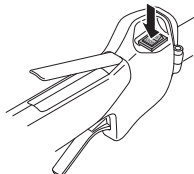

Start the engine and make sure the engine stops when you move the stop switch to the stop setting.

Cutting attachment guard

This guard is intended to prevent loose objects from being thrown towards the operator. The guard also protects the operator from accidental contact with the cutting attachment.

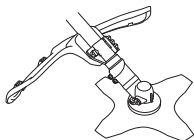

Check that the guard is undamaged and not cracked. Replace the guard if it has been exposed to impact or is cracked.

Always use the recommended guard for the cutting attachment you are using. See chapter on Technical data.



WARNING! Never use a cutting attachment without an approved guard. See the chapter on Technical data. If an incorrect or faulty guard is fitted this can cause serious personal injury.

Vibration damping system



Your machine is equipped with a vibration damping system that is designed to minimize vibration and make operation easier.

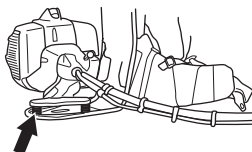

Using incorrectly wound cord or a blunt or incorrect cutting attachment (wrong type or incorrectly filed, see instructions under the heading Filing the blade) increases the level of vibration.

The machine's vibration damping system reduces the transfer of vibration between the engine unit/cutting equipment and the machine's handle unit.

Regularly check the vibration damping units for cracks or deformation. Check that the vibration damping element is undamaged and securely attached.



WARNING! Overexposure to vibration can lead to circulatory damage or nerve damage in people who have impaired circulation. Contact your doctor if you experience symptoms of overexposure to vibration. Such symptoms include numbness, loss of feeling, tingling, pricking, pain, loss of strength, changes in skin colour or condition. These symptoms normally appear in the fingers, hands or wrists. The risk increases at low temperatures.

Muffler

The muffler is designed to keep noise levels to a minimum and to direct exhaust fumes away from the user.

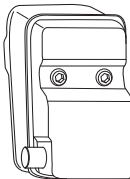

GENERAL SAFETY PRECAUTIONS

For mufflers it is very important that you follow the instructions on checking, maintaining and servicing your machine.

Never use a machine that has a faulty muffler.

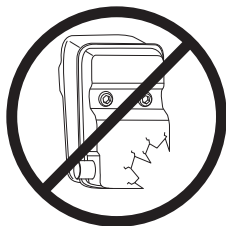

Regularly check that the muffler is securely attached to the machine.

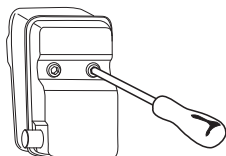

WARNING! The inside of the muffler contain chemicals that may be carcinogenic. Avoid contact with these elements in the event of a damaged muffler.



WARNING! Bear in mind that: The exhaust fumes from the engine are hot and may contain sparks which can start a fire. Never start the machine indoors or near combustible material!

Locking nut

A locking nut is used to secure some types of cutting attachment.



When fitting, tighten the nut in the opposite direction to the direction of rotation of the cutting attachment. To remove it, undo the nut in the same direction as the cutting

attachment rotates. (CAUTION! The nut has a left-hand thread.) Tighten the nut using the socket spanner.

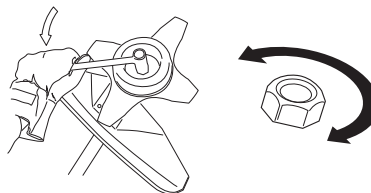

The nylon lining inside the locking nut must not be so worn that you can turn it by hand. The lining should offer a resistance of at least 1.5 Nm. The nut should be replaced after it has been put on approx. 10 times.

Harness



Check that the harness is not damaged.

In an emergency situation, release yourself from machine and harness according to the following method.

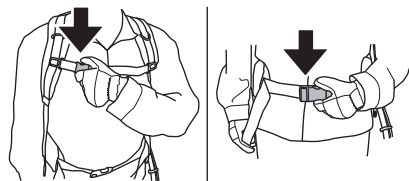

Cutting equipment

This section describes how to choose and maintain your cutting equipment in order to:

- Reduce the risk of blade thrust.
- Obtain maximum cutting performance.
- Extend the life of cutting equipment.

IMPORTANT!

Only use cutting attachments with the guards we recommend! See the chapter on Technical data.

Refer to the instructions for the cutting attachment to check the correct way to load the cord and the correct cord diameter.

Keep the teeth of the blade correctly sharpened! Follow our recommendations. Also refer to the instructions on the blade packaging.

GENERAL SAFETY PRECAUTIONS



WARNING! Always stop the engine before doing any work on the cutting attachment. This continues to rotate even after the throttle has been released. Ensure that the cutting attachment has stopped completely and disconnect the spark plug cap before you start to work on it.



WARNING! Using an incorrect cutting attachment or an incorrectly sharpened blade increases the risk of blade thrust.

Cutting equipment

Grass blades and grass knives are intended for cutting coarse grass.



A trimmer head is intended for trimming grass.



General rules



Only use cutting attachments with the guards we recommend! See the chapter on Technical data.

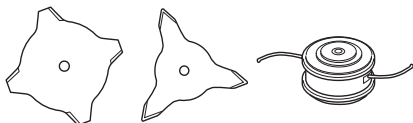

Keep the teeth of the blade correctly sharpened! Follow our instructions and use the recommended file gauge. An incorrectly sharpened or damaged blade increases the risk of accidents.

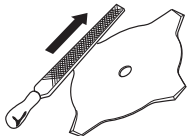

Check the cutting attachment for damage or cracks. A damaged cutting attachment should always be replaced.

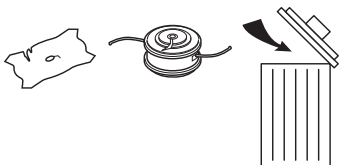

Sharpening grass knives and grass blades



- See the cutting attachment packaging for correct sharpening instructions. Sharpen blades and knives using a single-cut flat file.
- Sharpen all edges equally to maintain the balance of the blade.

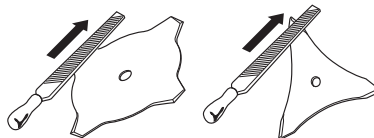

WARNING! Always discard a blade that is bent, twisted, cracked, broken or damaged in any other way. Never attempt to straighten a twisted blade so that it can be reused. Only use original blades of the specified type.

Trimmer head

IMPORTANT!

Always ensure the trimmer cord is wound tightly and evenly around the drum, otherwise the machine will generate harmful vibration.

- Only use the recommended trimmer heads and trimmer cords. These have been tested by the manufacturer to suit a particular engine size. This is especially important when a fully automatic trimmer head is used. Only use the recommended cutting attachment. See the chapter on Technical data.



- Smaller machines generally require small trimmer heads and vice versa. This is because when clearing using a cord the engine must throw out the cord radially from the trimmer head and overcome the resistance of the grass being cleared.
- The length of the cord is also important. A longer cord requires greater engine power than a shorter cord of the same diameter.
- Make sure that the cutter on the trimmer guard is intact. This is used to cut the cord to the correct length.
- To increase the life of the cord it can be soaked in water for a couple of days before use. This will make the cord tougher so that it lasts longer.

ASSEMBLY

Fitting the flexible drive shaft



- Loosen two screws at the shaft coupling.

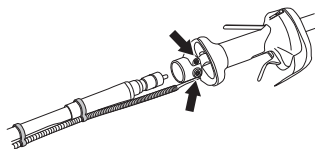

- Slide the flexible shaft through the loops at the cabling, and fit the flexible shaft to the shaft coupling. Make sure the shaft engages correctly by turning it and pushing at the same time.
- Tighten the two screws.
- Install the drive shaft sleeve in the clutch cover so that the hole is positioned directly underneath the locking button on the clutch cover.

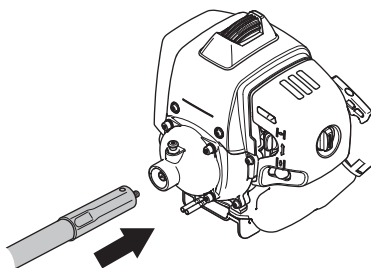

- Make sure the shaft engages correctly by turning it and pushing at the same time.
- Make sure the locking pin returns to its original position, so that the drive shaft sleeve cannot come off the clutch case.

Connecting throttle cable and stop switch wires



- Place the throttle wire from the cabling (A) and the throttle wire from the engine (B) in the plastic sleeve as shown.

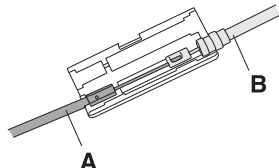

- Close the plastic sleeve.

- Plug the stop switch wires into the matching connectors from the engine. Note that wire polarity is not important.

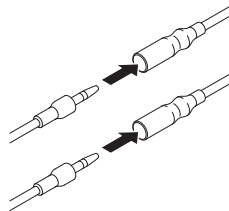

Fitting the J-handle



- Position the loop handle on the shaft. Note that the handle must be mounted below the arrow on the shaft.

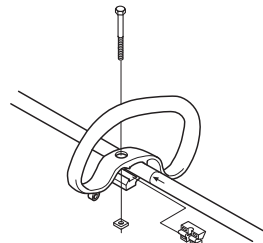

- Slide the spacer into the slot in the loop handle.
- Fit the nut and screw. Do not overtighten.
- Attach the J-handle to the loop handle using the three screws, as shown.

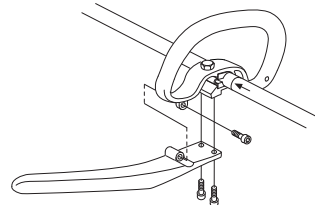

ASSEMBLY

- Now adjust the trimmer to give a comfortable working position. Tighten the bolt/knob.

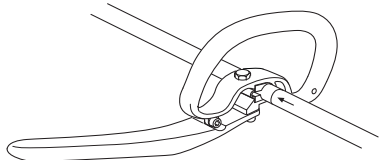

WARNING! Only grass blades/grass cutters or trimmer heads/plastic blades may be used when the J-handle is fitted. Saw blades must never be used with the J-handle.

Fitting blades and trimmer heads



WARNING! When fitting the cutting attachment it is extremely important that the raised section on the drive disc/support flange engages correctly in the centre hole of the cutting attachment. If the cutting attachment is fitted incorrectly it can result in serious and/or fatal personal injury.



WARNING! Never use a cutting attachment without an approved guard. See the chapter on Technical data. If an incorrect or faulty guard is fitted this can cause serious personal injury.

IMPORTANT! If a saw blade or grass blade are to be used the machine must be equipped with the correct handlebar, blade guard and harness.

Fitting the guard extension



CAUTION! The guard extension shall always be fitted when using the trimmer head/plastic blades and combination guard. The guard extension shall always be removed when using the grass blade and combination guard.

Hook the blade guard/combination guard (A) onto the fitting on the shaft and secure with the bolt.

Enter the guard extension guide in the slot of the combination guard. Then click the guard extension into position on the guard with the four quick-fasteners.

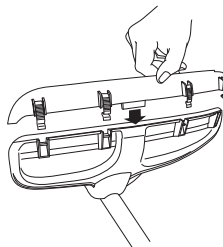

The guard extension is removed easily using a screwdriver, see illustration.

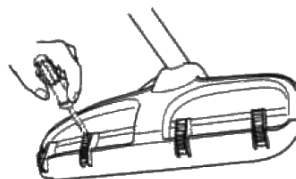

Fitting a blade guard, grass blade and grass cutter



- Hook the blade guard/combination guard (A) onto the fitting on the shaft and secure with the bolt (L). Use the recommended blade guard. See the Technical data section. **CAUTION!** Ensure that the guard extension is removed.

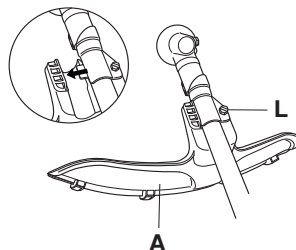

- Fit the drive disc (B) on the output shaft.
- Turn the output shaft until one of the holes in the drive disc aligns with the corresponding hole in the gear housing.
- Insert the locking pin (C) in the hole to lock the shaft.
- Place the blade (D), support cup (E) and support flange (F) on the output shaft.
- Fit the nut (G). The nut must be tightened to a torque of 35-50 Nm (3.5-5 kpm). Use the spanner in the tool kit. Hold the shaft of the spanner as close to the blade guard as possible. To tighten the nut, turn the spanner

ASSEMBLY

in the opposite direction to the direction of rotation
(Caution! left-hand thread).

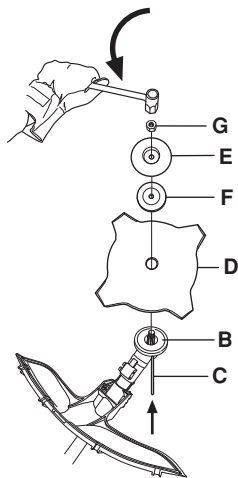

Fitting the trimmer guard and trimmer head



- Fit the correct trimmer guard (A) for use with the trimmer head. **CAUTION!** Ensure that the guard extension is fitted.

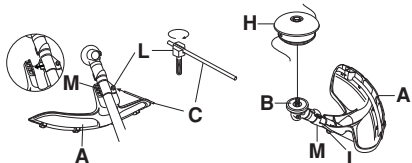

- Hook the trimmer guard/combination guard onto the fitting on the shaft and secure with the bolt (L).
- Fit the drive disc (B) on the output shaft.
- Turn the output shaft until one of the holes in the drive disc aligns with the corresponding hole in the gear housing.
- Insert the locking pin (C) in the hole to lock the shaft.
- Screw on the trimmer head/plastic blades (H) in the opposite direction to the direction of rotation.

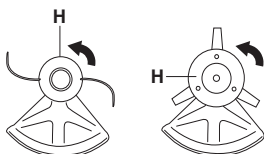

- To dismantle, follow the instructions in the reverse order.

Fitting the transport guard



- Insert the blade in the transport guard (A).
- Snap the two fasteners (B) into the slots (C) to secure the transport guard.

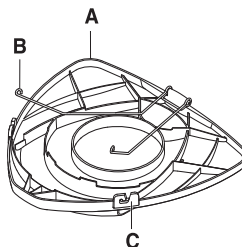

Adjusting the harness and brush cutter



Adjusting the backplate height

- Loosen the two fasteners holding the backplate.

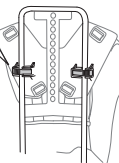
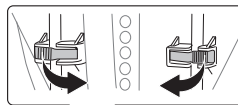

- Loosen the backplate from the frame on one side.

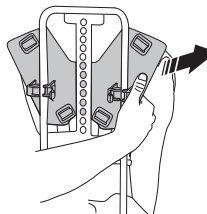

ASSEMBLY

- Move the backplate to the desired height and fasten it. Make sure the pin aligns with one of the holes on the frame, see picture.

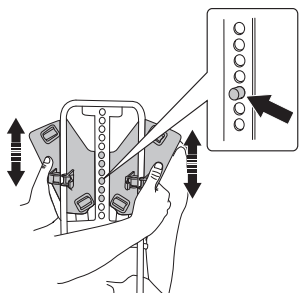

Adjusting the harness

- Put on the harness.
- Tighten the waist strap so that it sits securely.



- Tighten the chest strap.



- Adjust the chest strap vertically if needed and make sure it fits well.

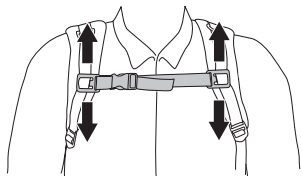

- Adjust the shoulder straps to distribute the load evenly across your shoulders.



- Loosen or tighten the waist strap so that approx. 70% of the load is on your waist and 30% on your shoulders.

Assembling and dismantling the two-piece shaft

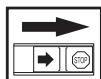

Assembly

- Loosen the coupling by turning the knob anticlockwise.
- Align the tab of the attachment (A) with the arrow on the coupling (B).

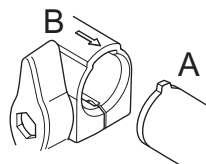

- Push the attachment into the coupling until the attachment snaps into place.

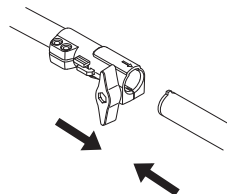

- Before using the unit, tighten the knob securely.

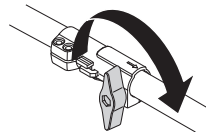

ASSEMBLY

Dismantling

- Loosen the coupling by turning the knob (at least 3 times).

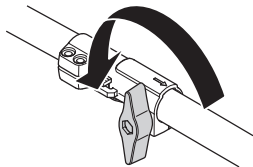

- Push and hold the button (C). While securely holding the engine end, pull the attachment straight out of the coupling.

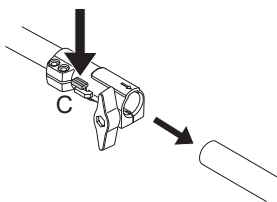

FUEL HANDLING

Fuel safety

Never start the machine:

- 1 If you have spilled fuel on it. Wipe off the spillage and allow remaining fuel to evaporate.
- 2 If you have spilled fuel on yourself or your clothes, change your clothes. Wash any part of your body that has come in contact with fuel. Use soap and water.
- 3 If the machine is leaking fuel. Check regularly for leaks from the fuel cap and fuel lines.

Transport and storage

- Store and transport the machine and fuel so that there is no risk of any leakage or fumes coming into contact with sparks or open flames, for example, from electrical machinery, electric motors, electrical relays/ switches or boilers.
- When storing and transporting fuel always use approved containers intended for this purpose.
- When storing the machine for long periods the fuel tank must be emptied. Contact your local petrol station to find out where to dispose of excess fuel.
- Ensure the machine is cleaned and that a complete service is carried out before long-term storage.
- The transport guard must always be fitted to the cutting attachment when the machine is being transported or in storage.
- Secure the machine during transport.



WARNING! Take care when handling fuel. Bear in mind the risk of fire, explosion and inhaling fumes.

Fuel

CAUTION! The machine is equipped with a two-stroke engine and must always be run using a mixture of petrol and two-stroke oil. It is important to accurately measure the amount of oil to be mixed to ensure that the correct mixture is obtained. When mixing small amounts of fuel, even small inaccuracies can drastically affect the ratio of the mixture.



WARNING! Fuel and fuel fumes are highly inflammable and can cause serious injury when inhaled or allowed to come in contact with the skin. For this reason observe caution when handling fuel and make sure there is adequate ventilation.

Petrol



CAUTION! Always use a quality petrol/oil mixture at least 90 octane (RON). If your machine is equipped with a catalytic converter (see chapter on Technical data) always use a good quality unleaded petrol/oil mixture. Leaded petrol will destroy the catalytic converter.

Use low-emission petrol, also known as alkylate petrol, if it is available.

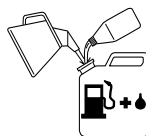

Ethanol blended fuel, E10 may be used (max 10% ethanol blend). Using ethanol blends higher than E10 will create lean running condition which can cause engine damage.

- The lowest octane recommended is 90 (RON). If you run the engine on a lower octane grade than 90 so-called knocking can occur. This gives rise to a high engine temperature, which can result in serious engine damage.
- When working at continuous high revs a higher octane rating is recommended.

Two-stroke oil

- For best results and performance use HUSQVARNA two-stroke engine oil, which is specially formulated for our air-cooled two-stroke engines.
- Never use two-stroke oil intended for water-cooled engines, sometimes referred to as outboard oil (rated TCW).
- Never use oil intended for four-stroke engines.
- A poor oil quality and/or too high oil/fuel ratio may jeopardise function and decrease the life time of catalytic converters.
- Mixing ratio
 1:50 (2%) with HUSQVARNA two-stroke oil.
 1:33 (3%) with oils class JASO FB or ISO EGB formulated for air-cooled, two-stroke engines.

Petrol, litre	Two-stroke oil, litre	
	2% (1:50)	3% (1:33)
5	0,10	0,15
10	0,20	0,30
15	0,30	0,45
20	0,40	0,60

FUEL HANDLING

Mixing

- Always mix the petrol and oil in a clean container intended for fuel.
- Always start by filling half the amount of the petrol to be used. Then add the entire amount of oil. Mix (shake) the fuel mixture. Add the remaining amount of petrol.
- Mix (shake) the fuel mixture thoroughly before filling the machine's fuel tank.



- Do not mix more than one month's supply of fuel at a time.
- If the machine is not used for some time the fuel tank should be emptied and cleaned.



WARNING! The catalytic converter muffler gets very hot during and after use. This also applies during idling. Be aware of the fire hazard, especially when working near flammable substances and/or vapours.

Fueling



WARNING! Taking the following precautions, will lessen the risk of fire:

Do not smoke or place hot objects near fuel.

Always shut off the engine before refuelling.

Always stop the engine and let it cool for a few minutes before refuelling.

When refuelling, open the fuel cap slowly so that any excess pressure is released gently.

Tighten the fuel cap carefully after refuelling.

Always move the machine away from the refuelling area and source before starting.

- Always use a fuel container with an anti-spill valve.
- Clean the area around the fuel cap. Contamination in the tank can cause operating problems.
- Ensure that the fuel is well mixed by shaking the container before filling the tank.

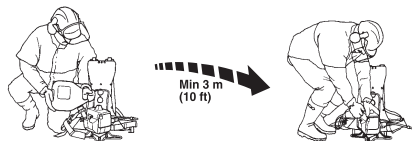

STARTING AND STOPPING

Check before starting



- Never use the machine without a guard nor with a defective guard.
- All covers must be correctly fitted and undamaged before you start the machine.
- Check the blade to ensure that no cracks have formed at the bottom of the teeth or by the centre hole. The most common reason why cracks are formed is that sharp corners have been formed at the bottom of the teeth while sharpening or that the blade has been used with dull teeth. Discard a blade if cracks are found.

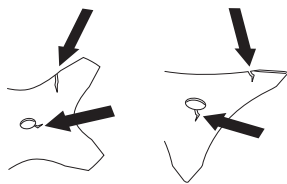

- Check that the support flange is not cracked due to fatigue or due to being tightened too much. Discard the support flange if it is cracked.

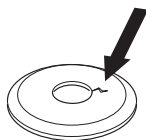

- Ensure the locking nut has not lost its captive force. The nut lock should have a locking force of at least 1.5 Nm. The tightening torque of the locking nut should be 35-50 Nm.



- Check that the blade guard is not damaged or cracked. Replace the blade guard if it is exposed to impact or is cracked.

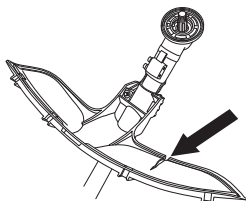

- Check that the trimmer head and trimmer guard are not damaged or cracked. Replace the trimmer head or

trimmer guard if they have been exposed to impact or are cracked.

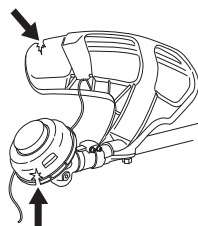

Starting and stopping



WARNING! The complete clutch cover and shaft must be fitted before the machine is started, otherwise the clutch can come loose and cause personal injury.

Always move the machine away from the refuelling area and source before starting. Place the machine on a flat surface. Ensure the cutting attachment cannot come into contact with any object.

Make sure no unauthorised persons are in the working area. Otherwise there is a risk of serious personal injury. The safety distance is 15 meters.

Starting



Ignition: Set the stop switch to the start position.

Primer bulb: Press the air purge repeatedly until fuel begins to fill the bulb. The bulb need not be completely filled.

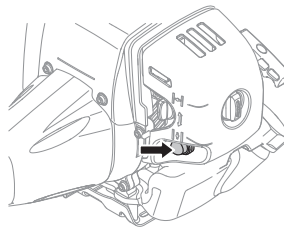

STARTING AND STOPPING

Choke: Set the choke control in the choke position.

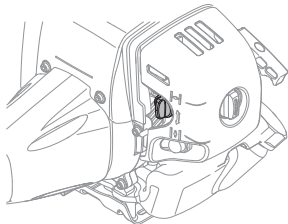

WARNING! When the engine is started with the choke in either the choke or start throttle positions the cutting attachment will start to rotate immediately.

Hold the body of the machine on the ground using your left hand (CAUTION! Not with your foot!). Grip the starter handle, slowly pull out the cord with your right hand until you feel some resistance (the starter pawls grip), now quickly and powerfully pull the cord. **Never twist the starter cord around your hand.**

Repeat pulling the cord until the engine starts. When the engine starts, return choke control to run position and apply full throttle; the throttle will automatically disengage from the start setting.

CAUTION! Do not pull the starter cord all the way out and do not let go of the starter handle when the cord is fully extended. This can damage the machine.

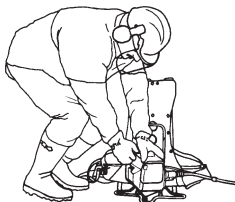

CAUTION! Do not put any part of your body in marked area. Contact can result in burns to the skin, or electrical shock if the spark plug cap has been damaged. Always use gloves. Do not use a machine with damaged spark plug cap.

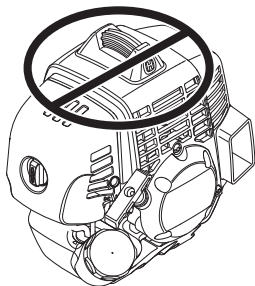

Stopping



Stop the engine by switching off the ignition.

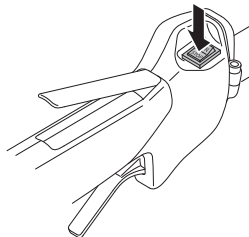

WORKING TECHNIQUES

General working instructions

IMPORTANT!

This section describes the basic safety precautions for working with brush cutters and trimmers.

If you encounter a situation where you are uncertain how to proceed you should ask an expert. Contact your dealer or your service workshop.

Avoid all usage which you consider to be beyond your capability.

You must understand the difference between forestry clearing, grass clearing and grass trimming before use.

Basic safety rules



- 1 Look around you:
 - To ensure that people, animals or other things cannot affect your control of the machine.
 - To ensure that people, animals, etc., do not come into contact with the cutting attachment or loose objects that are thrown out by the cutting attachment.
 - CAUTION! Do not use the machine unless you are able to call for help in the event of an accident.
- 2 Inspect the working area. Remove all loose objects, such as stones, broken glass, nails, steel wire, string, etc. that could be thrown out or become wrapped around the cutting attachment.
- 3 Do not use the machine in bad weather, such as dense fog, heavy rain, strong wind, intense cold, etc. Working in bad weather is tiring and can lead to dangerous conditions, e.g. slippery surfaces.
- 4 Make sure you can move and stand safely. Check the area around you for possible obstacles (roots, rocks, branches, ditches, etc.) in case you have to move suddenly. Take great care when working on sloping ground.



- 5 Always carry this backpack type brushcutter in its shoulder harness while operating.
- 6 Do not overreach. Keep proper footing and balance at all times.

- 7 Always hold the machine with both hands. Keep all parts of your body away from the hot surfaces. Keep all parts of your body away from the rotating cutting attachment.
- 8 Always work with the cutting attachment below waist level.
- 9 Switch off the engine before moving to another area. Fit the transport guard before carrying or transporting the equipment any distance.
- 10 Never put the machine down with the engine running unless you have it in clear sight.



WARNING! Neither the operator of the machine nor anyone else may attempt to remove the cut material while the engine is running or the cutting equipment is rotating, as this can result in serious injury.

Stop the engine and cutting equipment before you remove material that has wound around the blade shaft as otherwise there is a risk of injury. The bevel gear can get hot during use and may remain so for a while afterwards. You could get burnt if you touch it.



WARNING! Watch out for thrown objects. Always wear approved eye protection. Never lean over the cutting attachment guard. Stones, rubbish, etc. can be thrown up into the eyes causing blindness or serious injury.

Keep unauthorised persons at a distance. Children, animals, onlookers and helpers should be kept outside the safety zone of 15 metres. Stop the machine immediately if anyone approaches. Never swing the machine around without first checking behind you to make sure no-one is within the safety zone.

Basic working techniques

Always slow the engine to idle speed after each working operation. Long periods at full throttle without any load on the engine can lead to serious engine damage.



WARNING! Sometimes branches or grass get caught between the guard and cutting attachment. Always stop the engine before cleaning.

WORKING TECHNIQUES



WARNING! Machines fitted with saw blades or grass blades can be thrown violently to the side when the blade comes into contact with a fixed object. This is called blade thrust. A blade thrust can be violent enough to cause the machine and/or operator to be propelled in any direction, and possibly lose control of the machine. Blade thrust can occur without warning if the machine snags, stalls or binds. Blade thrust is more likely to occur in areas where it is difficult to see the material being cut.

Avoid cutting with the area of the blade between the 12 o'clock and 3 o'clock positions. Because of the speed of rotation of the blade, blade thrust can occur if you attempt to cut thick stems with this area of the blade.

Grass clearing using a grass blade



- Grass blades and grass knives must not be used on woody stems.
- A grass blade is used for all types of tall or coarse grass.
- The grass is cut down with a sideways, swinging movement, where the movement from right-to-left is the clearing stroke and the movement from left-to-right is the return stroke. Let the left-hand side of the blade (between 8 and 12 o'clock) do the cutting.

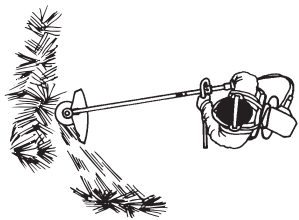

- If the blade is angled to the left when clearing grass, the grass will collect in a line, which makes it easier to collect, e.g. by raking.
- Try to work rhythmically. Stand firmly with your feet apart. Move forward after the return stroke and stand firmly again.
- Let the support cup rest lightly against the ground. It is used to protect the blade from hitting the ground.
- Reduce the risk of material wrapping around the blade by following these instructions:
 - Always work at full throttle.
 - Avoid the previously cut material during the return stroke.

- Stop the engine, unclip the harness and place the machine on the ground before you start to collect the cut material.

Grass trimming with a trimmer head



Trimming

- Hold the trimmer head just above the ground at an angle. It is the end of the cord that does the work. Let the cord work at its own pace. Never press the cord into the area to be cut.



- The cord can easily remove grass and weeds up against walls, fences, trees and borders. However it can also damage sensitive bark on trees and bushes, and damage fence posts.
- Reduce the risk of damaging plants by shortening the cord to 10-12 cm and reducing the engine speed.

Clearing

- The clearing technique removes all unwanted vegetation. Keep the trimmer head just above the ground and tilt it. Let the end of the cord strike the ground around trees, posts, statues and the like. **CAUTION!** This technique increases the wear on the cord.



- The cord wears quicker and must be fed forward more often when working against stones, brick, concrete, metal fences, etc., than when coming into contact with trees and wooden fences.
- When trimming and clearing, you should use less than full throttle (80%) so that the cord lasts longer and to reduce the wear on the trimmer head.

Cutting

- The trimmer is ideal for cutting grass that is difficult to reach using a normal lawn mower. Keep the cord parallel to the ground when cutting. Avoid pressing the trimmer head against the ground as this can ruin the lawn and damage the tool.

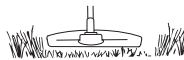

- Do not allow the trimmer head to constantly come into contact with the ground during normal cutting. Constant contact of this type can cause damage and wear to the trimmer head.

WORKING TECHNIQUES

Sweeping

- The fan effect of the rotating cord can be used for quick and easy clearing up. Hold the cord parallel to and above the area to be swept and move the tool side to side.

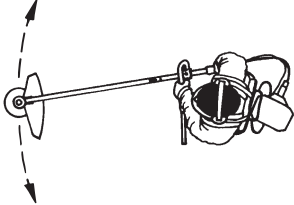

- When cutting and sweeping you should use full throttle to obtain the best results.

MAINTENANCE

Carburettor

Adjusting the idle speed (T)

Check that the air filter is clean. When the idle speed is correct, the cutting attachment should not rotate. If adjustment is required, close (turn clockwise) the idle adjustment screw T, with the engine running, until the cutting attachment starts to rotate. Open (turn anticlockwise) the screw until the cutting attachment stops. The idle speed is correctly set when the engine runs smoothly in all positions, and there is a clear margin to the speed at which the cutting attachment starts to rotate.

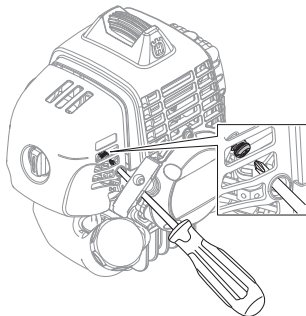

WARNING! If the idle speed cannot be adjusted so that the cutting attachment stops, contact your dealer/service workshop. Do not use the machine until it has been correctly adjusted or repaired.

Cooling system



To keep the working temperature as low as possible the machine is equipped with a cooling system.

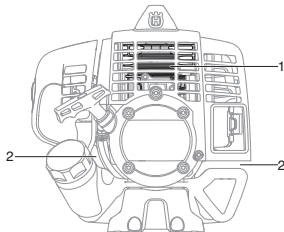

The cooling system consists of:

- 1 Cooling fins on the cylinder.
- 2 Air intake.

Clean the cooling system with a brush once a week, more often in demanding conditions. A dirty or blocked cooling

system results in the machine overheating which causes damage to the piston and cylinder.

Air filter

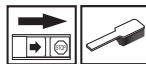

The air filter must be regularly cleaned to remove dust and dirt in order to avoid:

- Carburettor malfunctions.
- Starting problems.
- Loss of engine power.
- Unnecessary wear to engine parts.
- Excessive fuel consumption.

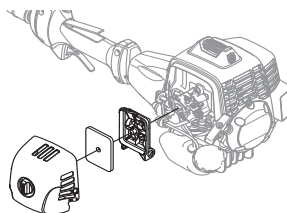

Clean the filter every 25 hours, or more regularly if conditions are exceptionally dusty.

Cleaning the air filter

Remove the air filter cover and take out the filter. Blow clean with compressed air.

An air filter that has been in use for a long time cannot be cleaned completely. The filter must therefore be replaced with a new one at regular intervals. **A damaged air filter must always be replaced.**

Fuel filter

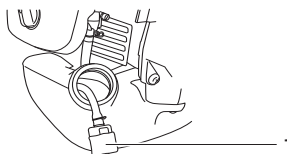

- 1 Fuel filter

When the engine runs short of fuel supply, check the fuel cap and the fuel filter for blockage.

MAINTENANCE

Two-piece shaft



The drive shaft end in the lower shaft should be lubricated with grease every 30 hours. There is a risk that the drive shaft ends (splined coupling) on models with two-piece shafts will seize if they are not lubricated regularly.

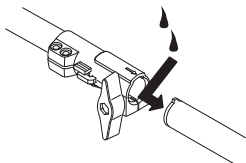

Bevel gear



The bevel gear is filled with the right quantity of grease at the factory. However, before using the machine you should check that the bevel gear is filled three-quarters full with grease. Use HUSQVARNA special grease.

The grease in the bevel gear does not normally need to be changed except if repairs are carried out.

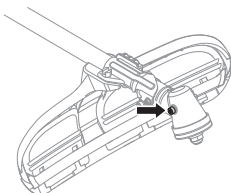

Spark plug



The spark plug condition is influenced by:

- Incorrect carburettor adjustment.
- An incorrect fuel mixture (too much or incorrect type of oil).
- A dirty air filter.

These factors cause deposits on the spark plug electrodes, which may result in operating problems and starting difficulties.

If the machine is low on power, difficult to start or runs poorly at idle speed: always check the spark plug first before taking any further action. If the spark plug is dirty, clean it and check that the electrode gap is 0,9-1,0 mm.

The spark plug should be replaced after about a month in operation or earlier if necessary.

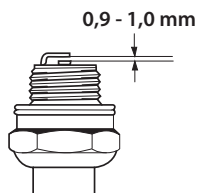

CAUTION! Always use the recommended spark plug type! Use of the wrong spark plug can damage the piston/cylinder. Check that the spark plug is fitted with a suppressor.

Drive shaft



The flexible drive axle is lubricated with Husqvarna drive axle grease. The axle must be lubricated at least every 6 months.

- Lift up the locking button that holds the drive shaft sleeve in the clutch cover.

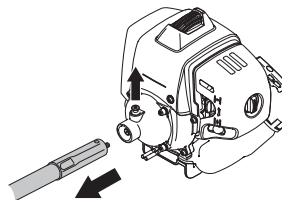

- Pull the drive shaft sleeve out of the clutch cover.
- Remove the drive shaft from the sleeve either by shaking it out or pulling it out using pliers.

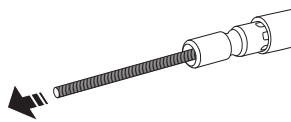

- Apply the grease from the tube along the whole axle. Spread with a brush or cloth.

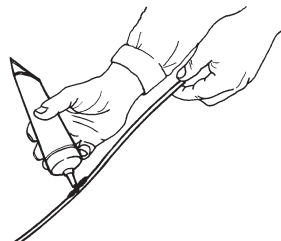

MAINTENANCE

- Slide the drive shaft back into the sleeve. Make sure the shaft engages correctly by turning it and pushing at the same time.

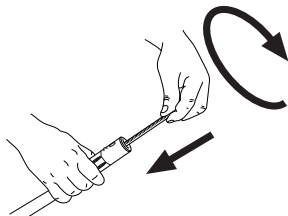

- When the shaft is correctly installed in the sleeve, the end of the shaft should project about 10 mm beyond the edge of the sleeve.

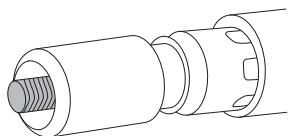

- Install the drive shaft sleeve in the clutch cover so that the hole is positioned directly underneath the locking button on the clutch cover.

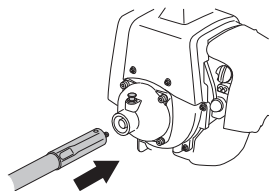

- Make sure the shaft engages correctly by turning it and pushing at the same time.

MAINTENANCE

Maintenance schedule

The following is a list of the maintenance steps that must be performed on the machine. Most of the items are described in the Maintenance section. The user must only carry out the maintenance and service work described in this Operator's Manual. More extensive work must be carried out by an authorized service workshop.

Maintenance	Daily maintenance	Weekly maintenance	Monthly maintenance
Clean the outside of the machine.	X		
Check that the harness is not damaged.	X		
Make sure the throttle trigger lock and the throttle function correctly from a safety point of view.	X		
Check that the handle and handlebar are undamaged and secured correctly.	X		
Check that the stop switch works correctly.	X		
Check that the cutting attachment does not rotate at idle.	X		
Clean the air filter. Replace if necessary.	X		
Check that the guard is undamaged and not cracked. Replace the guard if it has been exposed to impact or is cracked.	X		
Check that the blade is correctly centred, is sharp, and is not cracked. An off-centre blade will cause vibration that could result in damage to the machine.	X		
Check that the trimmer head is undamaged and not cracked. Replace the trimmer head if necessary.	X		
Check that the locking nut of the cutting equipment is tightened correctly.	X		
Check that the transport guard for the blade is intact and that it can be secured correctly.	X		
Check that nuts and screws are tight.	X		
Check that there are no fuel leaks from the engine, tank or fuel lines.	X		
Check the starter and starter cord.		X	
Check that the vibration damping elements are not damaged.		X	
Clean the outside of the spark plug. Remove it and check the electrode gap. Adjust the gap to 0,9-1,0 mm or replace the spark plug. Check that the spark plug is fitted with a suppressor.		X	
Clean the machine's cooling system.		X	
Clean the outside of the carburettor and the space around it.		X	
Check that the bevel gear is filled three-quarters full with lubricant. Fill if necessary using special grease.		X	
Check the fuel filter for contamination and the fuel hose for cracks or other defects. Replace if necessary.			X
Check all cables and connections.			X
Check the clutch, clutch springs and the clutch drum for wear. Replace if necessary by an authorized service workshop.			X
Replace the spark plug. Check that the spark plug is fitted with a suppressor.			X
Lubricate the drive axle with Husqvarna drive axle grease.	Do this every six months.		

TECHNICAL DATA

Technical data

543 RBS

Engine

Cylinder displacement, cm ³	40,1
Cylinder bore, mm	40,5
Stroke, mm	31,1
Idle speed, rpm	3000
Recommended max. speed, rpm	12000
Speed of output shaft, rpm	9600
Max. engine output, acc. to ISO 8893, kW/ rpm	1,5/9000
Catalytic converter muffler	No

Ignition system

Spark plug	NGK CMR7H-10
Electrode gap, mm	0,9-1,0

Fuel and lubrication system

Fuel tank capacity, litre	0,75
---------------------------	------

Weight

Weight without fuel, cutting attachment and guard, kg	9,3
---	-----

Noise levels

(see note 1)

Equivalent sound pressure level at the operator's ear, measured according to EN ISO 11806 and ISO 22868, dB(A):	96
---	----

Vibration levels

(see note 2)

Equivalent vibration levels ($a_{hv,eq}$) at handles, measured according to EN ISO 11806 and ISO 22867, m/s ²	4,0/2,7
--	---------

Note 1: Reported data for equivalent sound pressure level for the machine has a typical statistical dispersion (standard deviation) of 1 dB (A).

Note 2: Reported data for equivalent vibration level has a typical statistical dispersion (standard deviation) of 1 m/s².

Approved accessories	Type	Cutting attachment guard, Art. no.
Grass blade/grass cutter	Multi 300-3 (Ø 300 3 teeth)	537 33 16-03
	Multi 255-3 (Ø 255 3 teeth)	537 33 16-03
	Grass 275-4 (Ø 275 4 teeth)	537 33 16-03
	Grass 255-4 (Ø 255 4 teeth)	537 33 16-03
Trimmer head	T35, T35x (Ø 2.4 - 3.0 mm cord)	537 33 16-03
	T45x (Ø 2.7 - 3.3 mm cord)	537 33 16-03
	T55x (Ø 2.7 - 3.3 mm cord)	537 33 16-03
	F35 (Ø 2.0 - 3.5 mm cord)	537 33 16-03
Support cup	Fixed	-

The following attachments are recommended for the specified models.

Attachments	Art No.	Use with
Hedge trimmer attachment with shaft HA 850	967 02 67-01	543 RBK
Brushcutter attachment with SA 850 shaft.	967 02 69-01	543 RBK
Brushcutter attachment with GTA 850 shaft.	967 11 31-01	543 RBK

TECHNICAL DATA

EC Declaration of Conformity (Applies to Europe only)

We, **Husqvarna AB**, SE-561 82 Huskvarna, Sweden, tel: +46-36-146500, declare that the brush cutters **Husqvarna 543 RBX, 543 RBK** with serial numbers dating from 2012 onwards (the year is clearly stated on the rating plate, followed by the serial number), comply with the requirements of the COUNCIL'S DIRECTIVE:

- of May 17, 2006 "relating to machinery" **2006/42/EC**.

- of December 15, 2004 "relating to electromagnetic compatibility" **2004/108/EC**.

- of May 8, 2000 "relating to the noise emissions in the environment" **2000/14/EC**. Conformity assessment according to Annex V. For information relating to noise emissions, see the Technical data chapter.

The following standards have been applied:

EN ISO 12100:2010, CISPR 12:2009, ISO 14982:1998, EN ISO 11806-1:2011, EN ISO 11806-2:2011

SMP Svensk Maskinprovning AB, Box 7035, SE-750 07 Uppsala, Sweden, has carried out voluntary type approval for Husqvarna AB.

The certificate has the number:

543 RBX, 543 RBK - **SEC/12/2362**

Huskvarna, 21 December 2012



Per Gustafsson, Development manager (Authorized representative for Husqvarna AB and responsible for technical documentation.)

T35, T35x



<p>1</p>	<p>2</p>	<p>3</p>
<p>4</p>	<p>5</p>	
<p>6</p>	<p>7</p>	<p>8</p>
<p>9</p>		

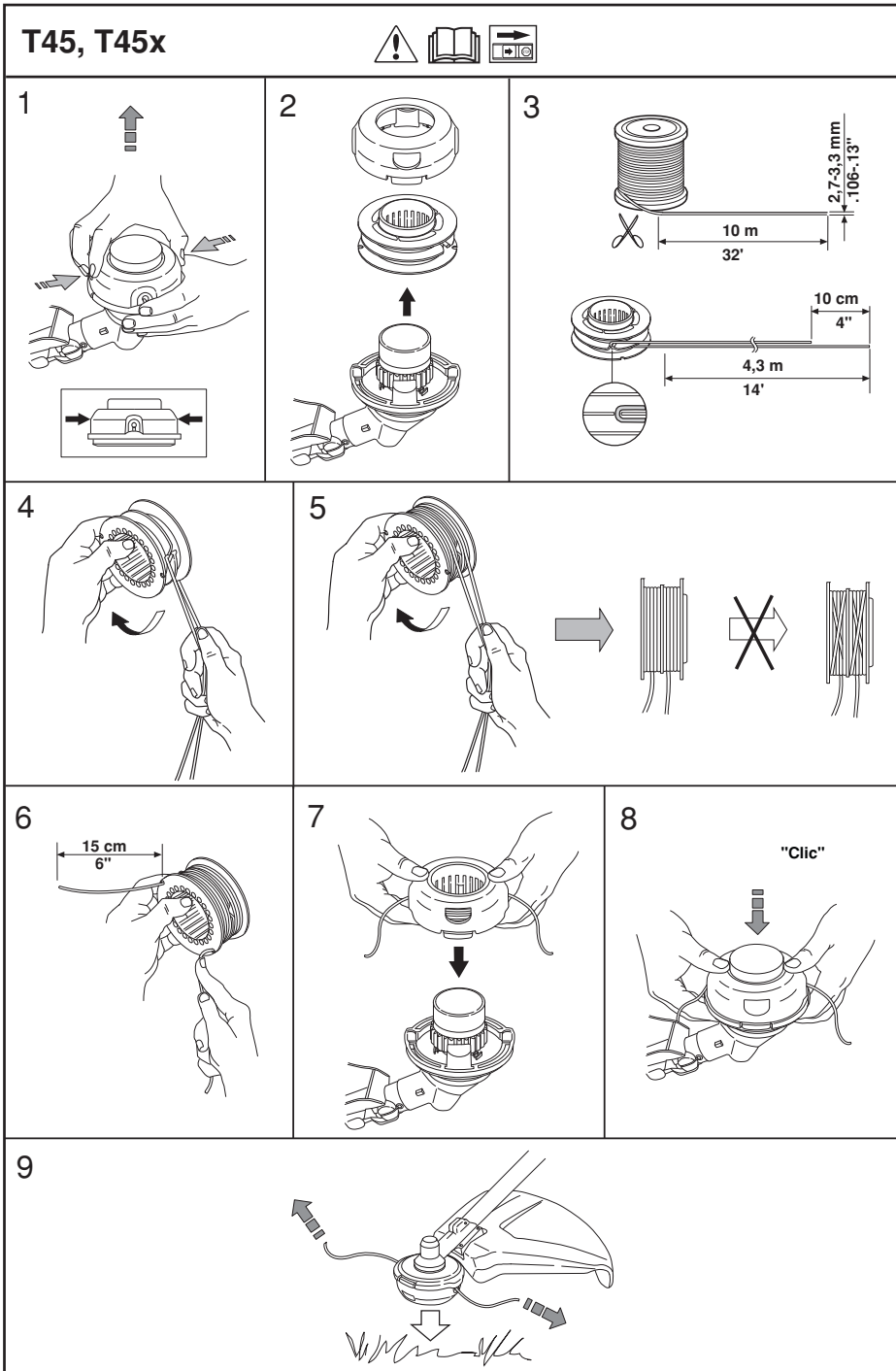

T55x



1

2

3

A	2,7 - 4,0 mm / .105 - .160"
B	8 m / 26'
C	15 cm / 5.9"

4

5

6

7

8

9

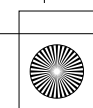
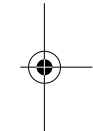
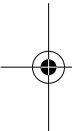
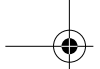



www.husqvarna.com

CN - 原始说明书
GB - Original instruction

1155319-73



2015-06-24

