



Operator Manual

Z 248F

Zero Turn Mower / 967303601-00



EN



Please read the operator manual carefully and make sure you understand the instructions before using the machine.

Gasoline containing up to 10% ethanol (E10) is acceptable for use in this machine. The use of any gasoline exceeding 10% ethanol (E10) will void the product warranty.

CONFORMITY CERTIFICATES

USA requirements

Labels are placed on the engine and/or in the engine compartment stating that the machine will fulfill the requirements. This is also applicable to special requirements for any of the states, (California emission rules etc.). Do not remove any of these labels. Certificates can also be supplied with the machine at delivery or written in the Engine manual. Take care of them as they are valuable documents.



WARNING! Failure to follow cautious operating practices can result in serious injury to the operator or other persons. The owner must understand these instructions, and must allow only trained persons who understand these instructions to operate the mower.

Each person operating the mower must be of sound mind and body and must not be under the influence of any mind altering substance.

When this product is worn out and no longer used, it should be returned to the reseller or other party for recycling.



WARNING! Engine exhaust, some of its constituents, and certain vehicle components contain or emit chemicals known to the State of California to cause cancer and birth defects or other reproductive harm.

To implement improvements, specifications and designs can be altered without prior notification.

Note that no legal demands can be placed based on the information contained in these instructions.

Use only original parts for repairs. The use of other parts voids the warranty.

Do not modify or install non-standard equipment to the unit without consent from the manufacturer. Modifications to the unit may cause unsafe operations or damage the unit.



WARNING! Battery posts, terminals and related accessories contain lead and lead compounds, chemicals known to the State of California to cause cancer and birth defects or other reproductive harm. Wash hands after handling.

CONTENTS

INTRODUCTION	4	Starting the Engine	16
Driving and Transport on Public Roads.....	4	Running	17
Towing.....	4	Stopping the Engine	18
Operating.....	4	Mowing Tips	18
Good Service.....	5	Operating On Hills	18
Manufacturing Number	5	Jumper Cable Use.....	19
SYMBOLS AND DECALS.....	6	Moving Machine By Hand	19
SAFETY	7	MAINTENANCE.....	20
Protecting Children	7	Maintenance Schedule.....	20
General Operation	7	Battery	22
Personal Safety Equipment	8	Safety System	23
Slope Operation.....	8	Park Brake	23
Safe Handling of Gasoline.....	8	Tire Pressures	23
General Maintenance	9	Caster Wheels	24
Transport.....	10	Anti-scalp Rollers.....	24
Towing.....	10	V-belts.....	24
Spark Arrestor.....	10	Adjusting the Mower Deck	25
CONTROLS.....	11	Leveling deck	25
Control Locations.....	11	Cutting Blades	26
Steering Control Levers	12	Blade replacement	26
Park Brake	12	Cleaning	26
Ignition Switch	12	LUBRICATION.....	27
Throttle Control	13	Transmission	27
Blade Switch.....	13	Wheel and Deck Zerks	27
Service Meter.....	13	Front Wheel Mount.....	27
Choke Control.....	13	Front Wheel Bearings	27
Fuse	14	Deck Spindles.....	27
Seat Adjustment Lever	14	TROUBLESHOOTING	28
Fuel Shut Off Valve	14	STORAGE	29
Cutting Height Lever.....	14	Winter Storage	29
Bypass Linkages	14	Service.....	29
Fuel Tank.....	15	SCHEMATIC	30
Tracking	15	TECHNICAL DATA	31
OPERATION	16	Torque Specifications	32
Training	16	Accessories	32
Steering	16	SERVICE JOURNAL.....	33
Before Starting.....	16		

INTRODUCTION

Congratulations

Thank you for purchasing a Husqvarna ride-on mower. This machine is built for superior efficiency to rapidly mow primarily large areas. A control panel easily accessible to the operator and a hydrostatic transmission regulated by steering controls both contribute to the machine's performance.

This manual is a valuable document. Read the contents carefully before using or servicing the machine. The following of instructions (use, service, maintenance) by all who operate this machine is important for the safety of the operator and others. It can also considerably increase the life span of the machine and increase its resale value.

If you sell your machine, be sure to give the operator manual to the new owner.

The final chapter of this operator manual provides a Service Journal. Ensure that service and repair work are documented. A well-kept service journal reduces service costs for the maintenance and affects the machine's resale value. Please contact your dealer for more information. Take the operator manual along when the machine is taken to your dealer for service.

General

In this operator manual, left and right, backward and forward are used in relation to the machine's normal driving direction. Continuous dedication to improve our products require that specifications and design are subject to change without notice.

Driving and Transport on Public Roads

Check applicable road traffic regulations before transporting on public roads. If the machine is transported, you must always use approved fastening equipment and ensure that the machine is well anchored. DO NOT operate this machine on public roadways.

Towing

If machine is equipped with a tow hitch, use extreme caution when towing. Never allow children or others in or on the towed equipment. Make wide turns to avoid jack-knifing. Travel slowly and allow extra distance to stop.

Do not tow on sloped ground. The weight of the towed equipment may cause loss of traction and loss of control.

Follow the manufacturer's recommendation for weight limits for towed equipment. Do not tow near ditches, canals, and other hazards.

Operating

This machine is constructed only for mowing grass on lawns and even ground without obstacles such as stones, tree stumps, etc. The machine can also be used for other tasks when equipped with special accessories provided by the manufacturer. Operating instructions for the accessories are provided with delivery. All other types of uses are incorrect. The manufacturer's directions concerning operation, maintenance, and repairs must be carefully followed.

Lawn mowers and all power equipment, can be potentially dangerous if used improperly. Safety requires good judgement, careful use in accordance with these instructions and common sense.

The machine must only be operated, maintained, and repaired by persons familiar with the machine's special characteristics and who are also knowledgeable about the safety instructions. Use only approved repair parts to maintain this machine.

Accident prevention regulations, other general safety regulations, occupational safety rules, and traffic regulations must be followed without fail.

Unauthorized modifications to the design of the machine may absolve the manufacturer from liability for any resulting personal injury or property damage.

INTRODUCTION

Good Service

Husqvarna's products are sold throughout the world and only in specialized retail stores with complete service. This ensures that you as a customer receive only the best support and service. Before the product is delivered, the machine has, for example, been inspected and adjusted by your retailer. See the certificate in the Service Journal in this operator manual.

When you need spare parts or support in service questions, warranty issues, etc., please consult the following professional:

This Manual belongs to the machine with the manufacturing number:	Engine

Manufacturing Number

The machine's manufacturing number can be found on the printed plate affixed to the engine compartment.

Stated on the plate, from the top are:

- The machine's type designation (I.D.).
- The manufacturer's type number (Model).
- The machine's serial number (Serial no.)

Please have the type designation and serial number available when ordering spare parts.

The engine's manufacturing number is stamped on one of the valve covers.

The plate states:

- The engine's model.
- The engine's type.
- Code

Please have these available when ordering spare parts.

The wheel motors and hydrostatic pumps have a barcode decal affixed at the rear.

SYMBOLS AND DECALS

These symbols are found on the machine and in the operator manual.

Study them carefully so that you know what they mean.

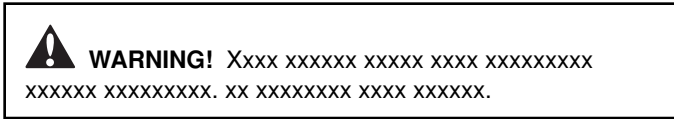

Used in this publication to notify the reader of a risk of personal injury or death, particularly if the reader should neglect to follow instructions given in the manual.

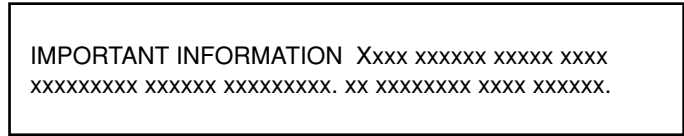

Used in this publication to notify the reader of a risk of material damage, particularly if the reader should neglect to follow instructions given in the manual. Used also when there is a potential for misuse or misassembly.



Reverse



Neutral



Fast



Slow



Choke



Fuel



Warning!



Park Brake



Cut Height Low



Cut Height High



Use protective glasses



Use protective gloves



Do not stand here



Battery acid is corrosive, explosive and flammable



Warning!
Keep away from the discharge deck, do not use without deflector or grass catcher



Do not touch parts



Wear hearing protection

Read Operator Manual

Shut off engine, remove key before performing maintenance or repair

Keep a safe distance from the machine

Use on slopes no greater than 10°

No passengers

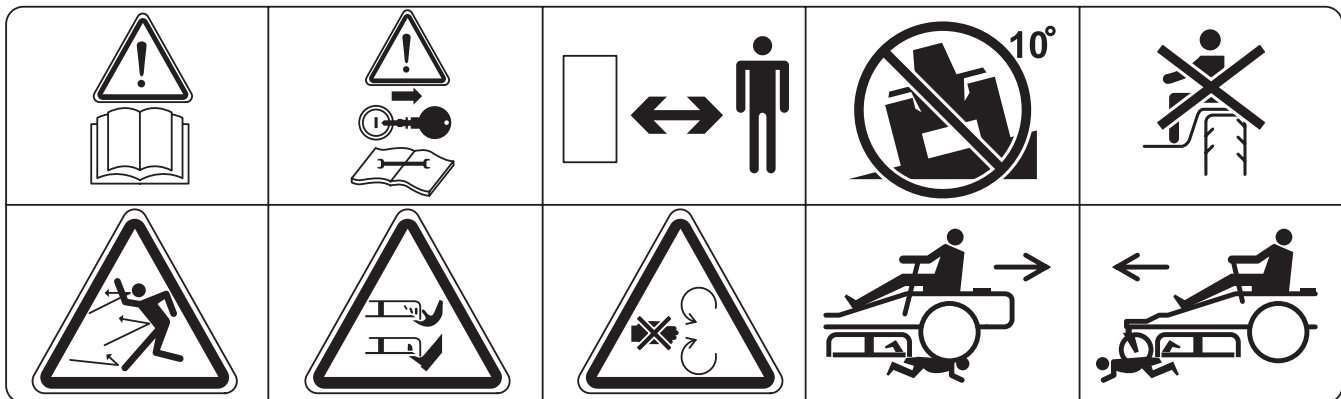

Whole body exposure to thrown objects

Severing of fingers and toes

Do not open or remove safety shields with engine running

Careful backing up, watch for other people

Careful going forward, watch for other people

SAFETY

Safety Instructions

These instructions are for your safety. Read them carefully.

WARNING! THIS CUTTING MACHINE IS CAPABLE OF AMPUTATING HANDS AND FEET AND THROWING OBJECTS. FAILURE TO OBSERVE THE FOLLOWING SAFETY INSTRUCTIONS COULD RESULT IN SERIOUS INJURY OR DEATH.

WARNING! CHILDREN CAN BE SERIOUSLY INJURED OR KILLED BY THIS EQUIPMENT. Carefully read and follow all the safety instruction that follow.

IMPORTANT INFORMATION The American Academy of Pediatrics recommends that children be a minimum of 16 years of age before operating a riding lawn mower.

Protecting Children

Tragic accidents can occur if the operator is not alert to the presence of children. Children are often attracted to the machine and the mowing activity. **Never** assume that children will remain where you last saw them.

- Keep children out of the mowing area and in the watchful care of a responsible adult **other than** the operator.
- Be alert and turn machine off if a child enters the area.
- Before and while backing, look behind and down for small children.
- Never carry children, even with the blades shut off. They may fall off and be seriously injured or interfere with safe machine operation. Children who have been given rides in the past may suddenly appear in the mowing area for another ride and be run over or backed over by the machine.
- Never allow children to operate the machine.
- Use extreme care when approaching blind corners, shrubs, trees, or other objects that may block your view of a child.

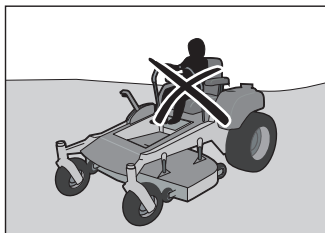
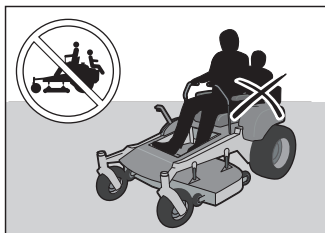

General Operation

- Read, understand, and follow all instructions on the machine and in the manual before starting.
- It is recommended that someone be aware that you are mowing and can provide help in case of injury or accident.
- Anyone who operates, maintains, and/or services this machine must first read and understand this Operator Manual. Local laws may regulate the age of the user. The owner is responsible for training the users of this equipment.
- The owner and operator of this equipment can prevent accidents and is responsible for accidents or injuries occurring to themselves, other people and/or property.
- Do not put hands or feet near rotating parts or under the machine. Keep clear of the discharge opening at all times.
- Only allow responsible adults, who are familiar with the instructions, to operate the machine.
- Clear the area of objects such as rocks, toys, wire, etc., which could be picked up and thrown by the blades.
- Be sure the area is clear of bystanders before operating. Stop machine if anyone enters the area.
- Do not mow in reverse unless absolutely necessary. Always look down and behind before and while backing.
- Never direct discharged material toward anyone. Avoid discharging material against a wall or obstruction. Material may ricochet back toward the operator. Stop the blades when crossing gravel surfaces.
- Do not operate machine without the entire grass catcher, discharge guard, or other safety devices in place and working.
- Slow down before turning.
- Never leave a running machine unattended. Always turn off blades, move the steering control lever outward to the park brake position, stop engine and remove keys before dismounting.
- Never carry passengers. The machine is only intended for use by one person.
- Disengage blades when not mowing. Shut off engine and wait for all parts to come to a complete stop before cleaning the machine, removing the grass catcher or unclogging the discharge guard.
- Operate the machine only in daylight or good artificial light.
- Do not operate the machine while under the influence of alcohol or drugs.
- Watch for traffic when operating near or crossing roadways.
- Use extra care when loading or unloading the machine into a trailer or truck.

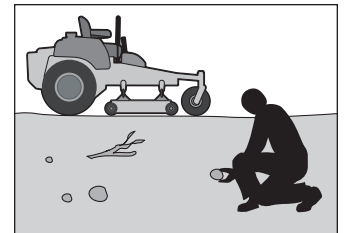
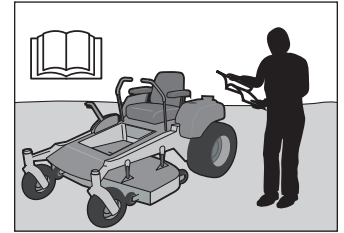

SAFETY

- Always wear eye protection when operating machine.
- Wear proper Personal Protective Equipment (PPE) while operating this machine, including (at a minimum) sturdy footwear, eye protection, and hearing protection. Do not mow in shorts and/or footwear with open toes.

! WARNING! When using the machine, approved personal protective equipment should be used. Personal protective equipment cannot eliminate the risk of injury but it will reduce the degree of injury if an accident does happen. Ask your retailer for help in choosing the right equipment.

- Data indicates that operators age 60 years and above are involved in a large percentage of riding mower-related injuries. These operators should evaluate their ability to operate the riding mower safely enough to protect themselves and others from serious injury.
- Follow the manufacturer's recommendation for wheel weights or counterweights.
- Keep machine free of grass, leaves or other debris buildup which can touch hot exhaust or engine parts and burn. Do not allow the mower deck to plow leaves or other debris which can cause buildup to occur. Clean any oil or fuel spillage before operating or storing the machine.
- Allow machine to cool before storage.

Personal Safety Equipment

- Make sure that first aid equipment is close at hand when using the machine.
- Never use the machine when barefoot.
- Always wear protective shoes or boots, preferably with steel toe caps.
- Always wear approved protective glasses or a full visor when assembling or driving.
- Always wear gloves when handling the blades.
- Never wear loose clothing that can get caught in moving parts.
- Use ear protectors to avoid damage to hearing.

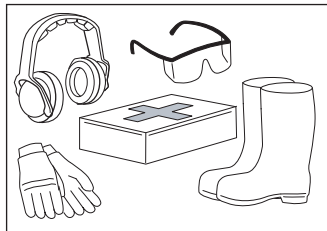

Slope Operation

Slopes are a major factor related to loss of control and tip-over accidents, which can result in severe injury or death. Operation on all slopes requires extra caution. If you cannot back up the slope or if you feel uneasy on it, do not mow it.

- Mow up and down slopes (10 degrees maximum), not across.
- Watch for holes, ruts, bumps, rocks, or other hidden objects. Uneven terrain could overturn the machine. Tall grass can hide obstacles.

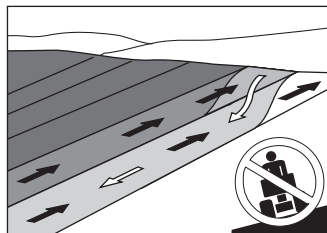

! WARNING! Do not drive up or down hills with slopes greater than 10 degrees. Do not drive across any slopes.

- Choose a low ground speed so that you will not have to stop while on the slope.
- Do not mow on wet grass. Tires may lose traction.
- Avoid starting, stopping, or turning on a slope. If the tires lose traction, disengage the blades and proceed slowly straight down the slope.
- Keep movement on the slopes slow and gradual. Do not make sudden changes in speed or direction, which could cause machine to roll over.
- Use extra care while operating machine with grass catchers or other attachments; they can affect the stability of the machine.
- Do not use on steep slopes.
- Do not try to stabilize the machine by putting a foot on the ground.
- Do not mow near drop-offs, ditches, or embankments. The machine could suddenly roll over if a wheel is over the edge or the edge caves in.



Safe Handling of Gasoline

! WARNING! The engine and the exhaust system become very hot during operation. There is a risk for burns if touched. Allow engine and exhaust system to cool before refueling.

To avoid personal injury or property damage, use extreme care in handling gasoline. Gasoline is extremely flammable and the vapors are explosive.

- Extinguish all cigarettes, cigars, pipes, and other sources of ignition.
- Use only approved gasoline containers.
- Never remove gas cap or add fuel with the engine running. Allow engine to cool before refueling.
- Never fuel the machine indoors.
- Never store the machine or fuel container where there is an open flame, spark or pilot light such as on a water heater or other appliance.
- Before you begin refueling, minimize the risk of static electricity by touching a metal surface.
- Never fill containers inside a vehicle or on a truck or trailer bed with plastic liner. Always place containers on the ground away from the vehicle when filling.
- Never overfill fuel tank. Replace gas cap and tighten securely.



SAFETY

- Remove gas-powered equipment from the truck or trailer and refuel it on the ground. If this is not possible, refuel such equipment with a portable container, rather than from a gasoline dispenser nozzle.
- Keep the nozzle in contact with the rim of the fuel tank or container opening at all times until fueling is complete. Do not use a nozzle lock-open device.
- If fuel is spilled on clothing, change clothing immediately.
- Do not start the engine near spilled fuel.
- Never use gasoline as a cleaning agent.
- If leaks arise in fuel system, the engine must not be started until problem has been resolved.
- Check the fuel level before each use and leave space for the fuel to expand, as the heat from the engine and the sun may otherwise cause the fuel to expand and overflow.
- Never make adjustments or repairs with the engine running.
- The blades are sharp and can cause cuts and gashes. Wrap the blades or use protective gloves when handling them.
- Never work with the starter circuit if there is spilled fuel.
- Ensure that the fuel filler cap is mounted tightly and no flammable substances are stored in an open vessel.
- Sparking can occur when working with the battery and the heavy cables of the starter circuit. This can cause battery explosion, fire or eye injury. Sparking will not occur after the grounding cable (normally negative, black) is removed from the battery.
- Disconnect the grounding cable from the battery first and reconnect it last.
- Do not make a bridge short circuit across the starter relay to run the starter.
- Be very careful when handling battery acid. Acid on skin can cause serious corrosive burns. If you spill battery acid on your skin, rinse immediately with water.
- Acid in the eyes can cause blindness, contact a doctor immediately.
- Be careful when servicing the battery. Explosive gases form in the battery. Never perform maintenance on the battery when smoking or near open flames or sparks. The battery can explode and cause serious injury or damage.
- The machine is tested and approved only with the equipment originally provided or recommended by the manufacturer. Only use approved repair parts for the machine.



CAUTION! Use protective glasses for maintenance work.

General Maintenance

- Never use the machine indoors or in spaces lacking proper ventilation. The exhaust fumes contain carbon monoxide, an odorless and poisonous lethal gas.
- Make sure that the equipment is in good condition and that all nuts and bolts, especially those fastening the blade attachments, are properly tightened and torqued.
- Maintain or replace safety and instruction labels as necessary.
- Never interfere with the intended function of a safety device or reduce the protection provided by a safety device. Check their proper operation regularly. NEVER operate a machine with a safety device that does not function properly.

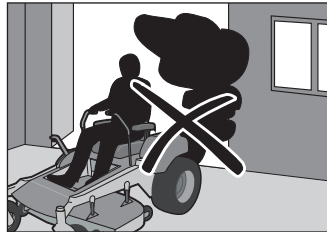

WARNING! The engine must not be started when the driver's floor plate or any protective plate for the mower deck's drive belt is removed.

- Check grass catcher components and the discharge guard frequently and replace with manufacturer's recommended parts when necessary.
- Do not change the settings of governors and avoid running the engine with overly high engine speeds. If you run the engine too fast, machine components could be damaged.
- To reduce the risk of fire, keep machine free of grass, leaves or other debris buildup. Clean oil or fuel spills and remove any fuel-soaked debris. Allow machine to cool before storing.
- Stop to inspect the equipment if you run over or into anything. If necessary, make repairs before starting.

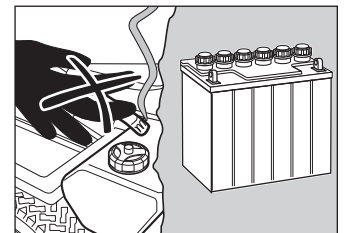
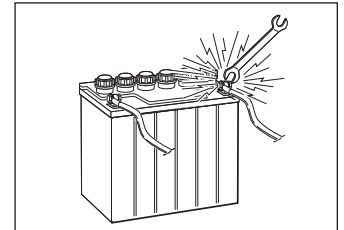

WARNING! The battery contains lead and lead compounds, chemicals that are considered to cause cancer, birth defects, and other reproductive system damage. Wash your hands after handling the battery.

- Check the park brake's functionality regularly. Adjust and service as necessary.
- The mulch blades should only be used in familiar areas when higher quality mowing is desired.
- Regularly clean deck and underside of deck, avoid spraying engine and electrical components with water.

SAFETY

Transport

 **WARNING!** Use extreme caution when loading the machine into a truck or trailer using ramps. There is the possibility of serious injury or death if the machine falls off the ramps.

IMPORTANT INFORMATION The park brake is not sufficient to lock the machine in place during transport. Ensure that the machine is well fastened to the transport vehicle. Always reverse the machine onto the transport vehicle to avoid tipping it over.

- The machine is heavy and can cause serious crushing injuries. Be extra cautious when it is loaded on or unloaded from a vehicle or trailer.
- Use full width ramps for loading machine into a trailer or truck.
- Use an approved trailer to transport the machine. Activate the park brake by securing the steering controls in the outward position with elastic or ratcheting straps. Turn off the fuel supply. Fasten the machine down with approved devices such as bands, chains or straps.
- Both front and rear tie down straps should be used and directed down and outward from the machine.
- Do not operate this machine on public roadways.
- Check and abide by local traffic regulations before transporting the machine on any road.
- Do not tow this machine, it may cause damage to the drive system.
- Do not tow any trailers, etc. with this mower. They may jackknife or overturn, causing damage to the mower and possible serious injury to the operator.
- Load the unit onto truck or trailer by driving up ramps of suitable strength using a slow speed. Do not lift! The machine is not intended to be lifted by hand.
- When loading or unloading this machine, do not exceed the maximum recommended operation angle of 10°.

Towing

If machine is equipped with a tow hitch, use extreme caution when towing. Never allow children or others in or on towed equipment..

Make wide turns to avoid jack-knifing. Travel slowly and allow extra distance to stop. Do not tow on sloped ground. The weight of the towed equipment may cause loss of traction and loss of control.

Follow the manufacturer's recommendation for weight limits for towed equipment. Do not tow near ditches, canals, and other hazards.

Spark Arrestor

This mower is equipped with an internal combustion engine and should not be used on or near any unimproved forested, bush covered or grassy lands unless the engine's system is equipped with a spark arrestor meeting applicable local or state laws (if any).

Federal laws apply on federal lands.

If a spark arrestor is used, it should be maintained in effective working order by the operator.

A spark arrestor for the muffler is available through your authorized Husqvarna dealer.

 **WARNING!** Engine exhaust and certain vehicle components contain or emit chemicals considered to cause cancer, birth defects, or other reproductive system damage. The engine exhaust contains carbon monoxide, which is an odorless, colorless, poisonous gas. Do not use the machine in enclosed spaces.

CONTROLS

This operator manual describes the Husqvarna Zero Turn Rider. The rider is fitted with a Briggs & Stratton four-stroke overhead valve engine.

Transmission from the engine is made via a belt-driven hydraulic pumps. Using the left and right steering controls, the flow is regulates the direction and speed.

Control Locations

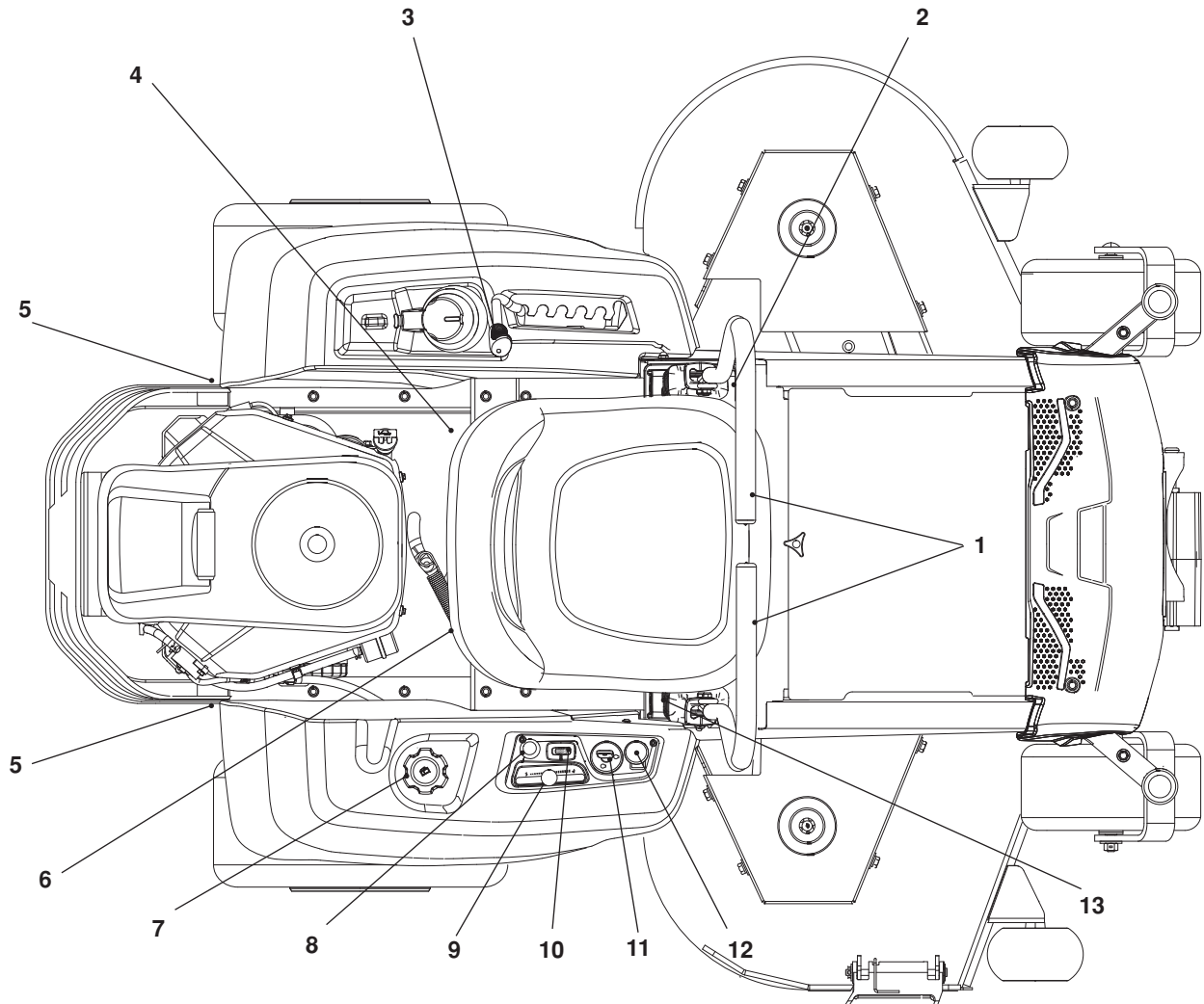

- | | |
|-----------------------------------|---------------------------|
| 1. Steering/Brake levers | 8. Choke control |
| 2. Tracking adjustment, left side | 9. Throttle control |
| 3. Deck lift | 10. Service meter |
| 4. Fuses | 11. Ignition switch |
| 5. Bypass linkages | 12. Blade switch |
| 6. Fuel shut off valve | 13. Seat adjustment lever |
| 7. Fuel tank | |

CONTROLS

Steering Control Levers

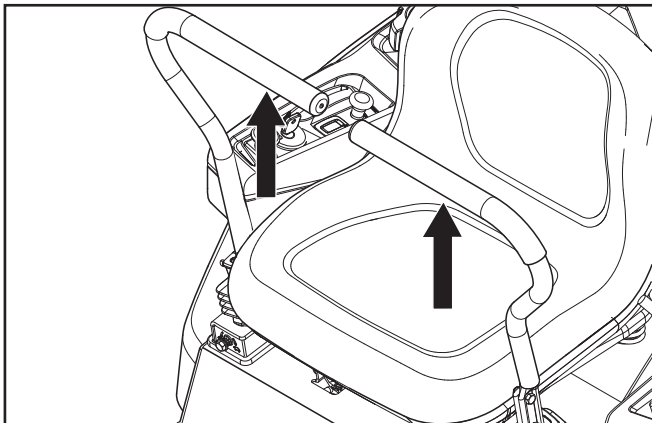

The machine's speed and direction are continuously variable using the two steering controls. The steering controls can be moved forward or backward about a neutral position. Furthermore, there is a neutral position, which is locked if the steering controls are moved outward.

When both controls are in the neutral position (N), the machine stands still.

By moving both controls an equal amount forward or backward, the machine moves in a straight line forward or backward respectively.

In order, for example, to turn right while moving forward, move the right control towards the neutral position. The rotation of the right wheel is reduced and the machine turns to the right.

Zero turn can be achieved by moving one control backward (behind the neutral position) and carefully moving the other steering control forward from its neutral position. The rotation direction when zero turning is determined by which steering control is moved backward behind the neutral position. If the left steering control is pulled backward, the machine turns to the left. Use extra care when using this maneuver.

If the steering controls are in uneven positions when standing still or do not fit in the slots for moving the controls outward, they can be adjusted.

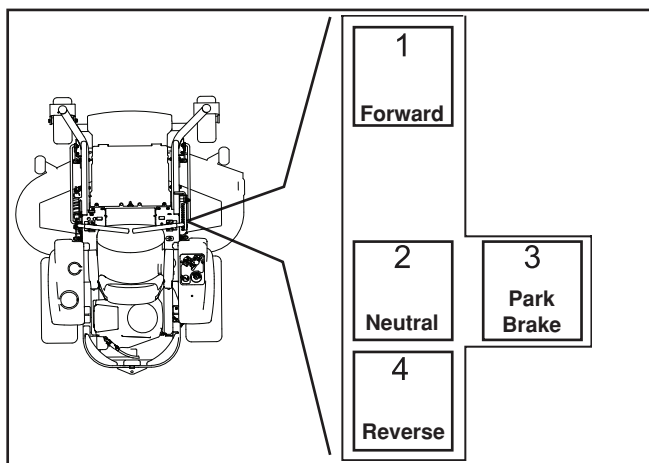

⚠ WARNING! The machine can turn very rapidly if one steering control is moved much further forward than the other.

Park Brake

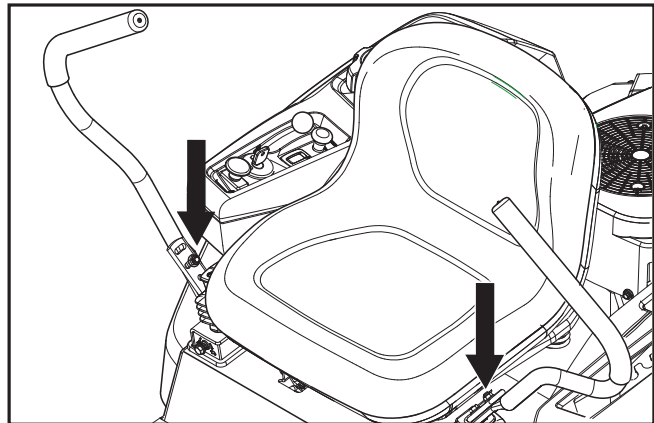

The park brake is integrated with the steering control levers. Move the levers outward from the neutral position to engage the park brake.

To release the park brake, rotate both steering control levers inwards to the neutral position. Do not attempt to operate the unit without both levers being inwards out of the engaged position or machine components could be damaged.

IMPORTANT INFORMATION The machine must stand absolutely still when applying the park brake. Always set the park brake before dismounting. Release the park brake before moving the mower.

Ignition Switch

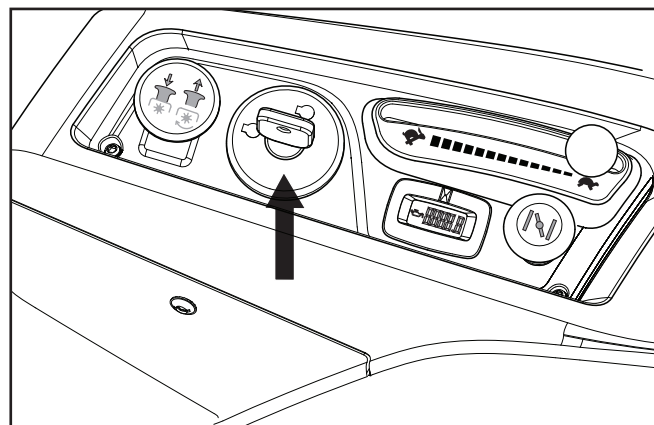

The ignition switch is placed on the control panel and is used to start and stop the engine.

CONTROLS

Throttle Control

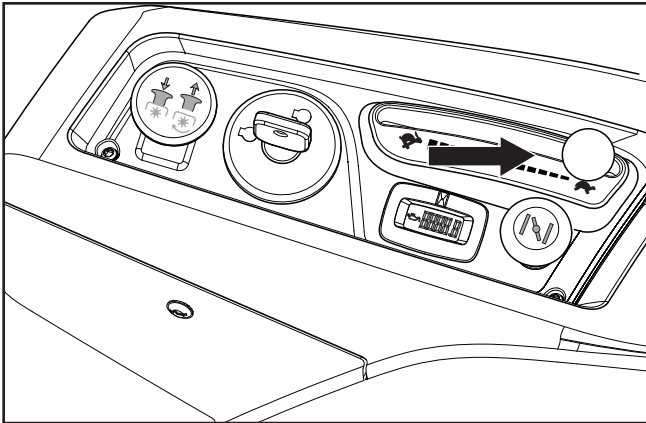

The throttle control regulates the engine speed and the rate of rotation of the blades, assuming the blade switch is pulled out. See **Blade Switch**.

To increase or decrease the engine speed, the control is moved forward or back respectively.

Avoid idling the engine for long periods, as there is a risk of fouling the spark plugs. **USE FULL THROTTLE WHEN MOWING**, for best mower performance and battery charging.

Service Meter

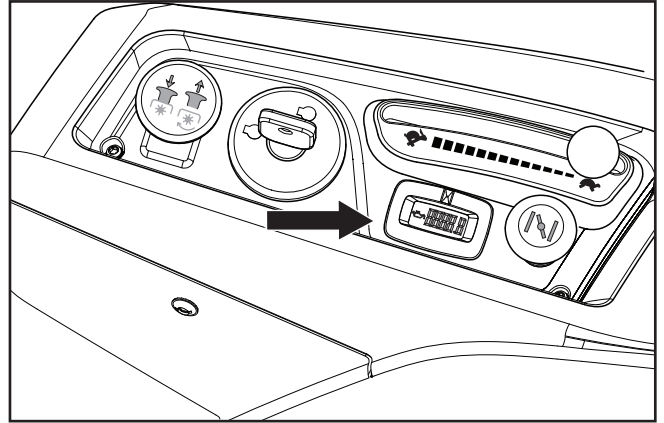

The service meter displays the total number of hours the engine has run and indicates when the engine and mower need servicing.

After every 50 hours of operation, an oil can icon will appear and stay on for two hours, before an automatic reset occurs. To manually reset the meter, turn the key off and on five times at one second intervals. To service the engine and mower, see the Service Journal of this manual.

Note: The service meter operates (clocks hours) only when the engine is running. Be sure to turn the key off when the unit is not in use, to prevent meter hours from accumulating.

Blade Switch

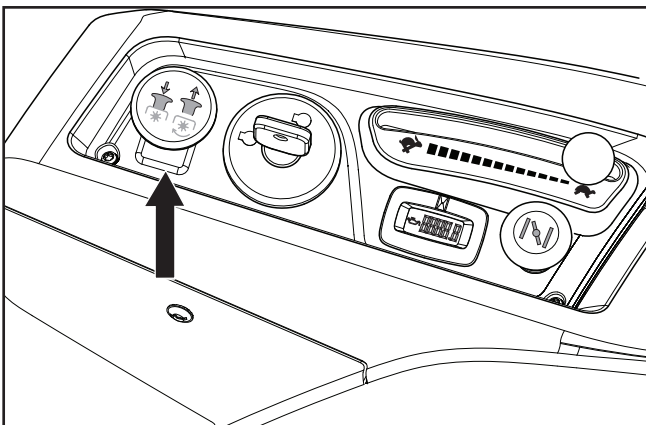

To engage the mower deck, pull the knob out; mower blades are disengaged when the knob is pressed down.

Choke Control

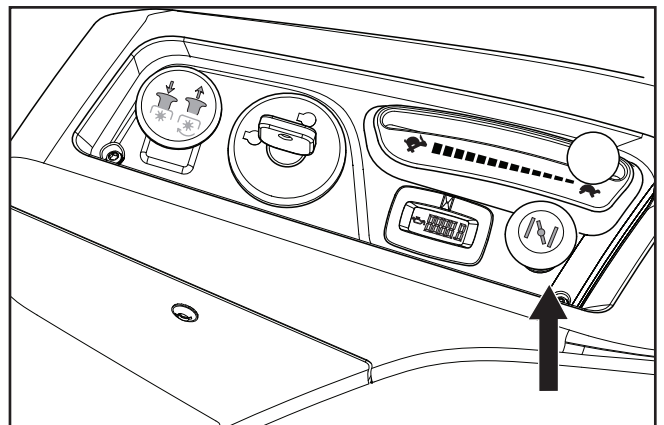

The choke control is used for cold starts to provide the engine with a richer fuel mixture.

For cold starts the control should be pulled up.

CONTROLS

Fuse

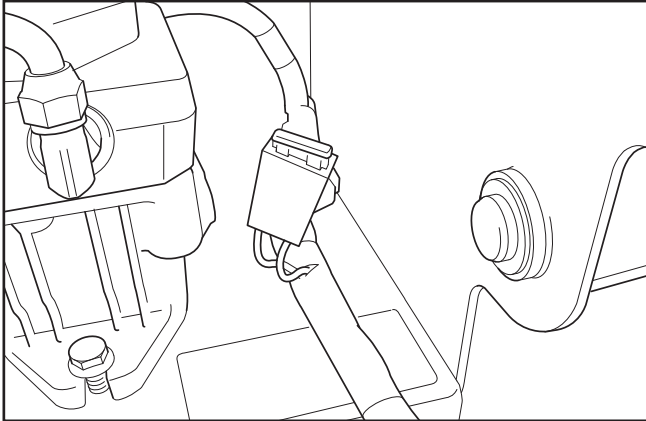

The 20 amp primary fuse is located on the left hand side of the machine. It is accessed by tilting the seat forward. The fuse is a flat pin type used in automobiles.

Seat Adjustment Lever

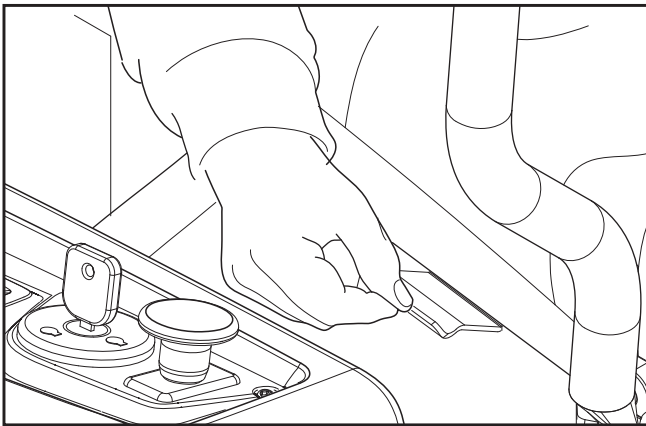

The seat can be adjusted lengthways. When making adjustments, the lever under the right side of the seat is pulled up, after which the seat can be moved backward or forward.

Fuel Shut Off Valve

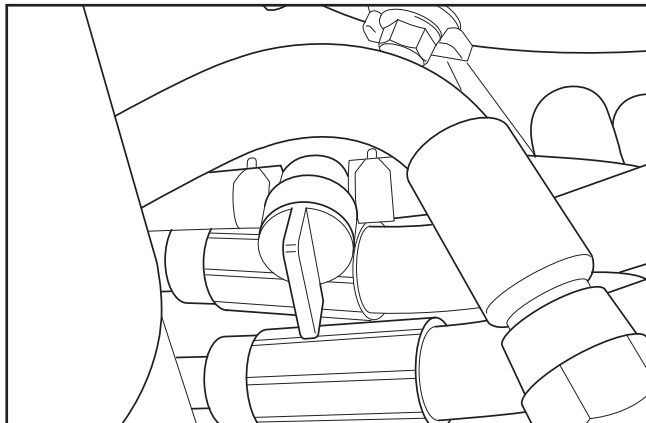

The fuel shut off valve is located at the right rear of the seat. The valve is off when the handle tab is turned perpendicular to the fuel line.

Cutting Height Lever

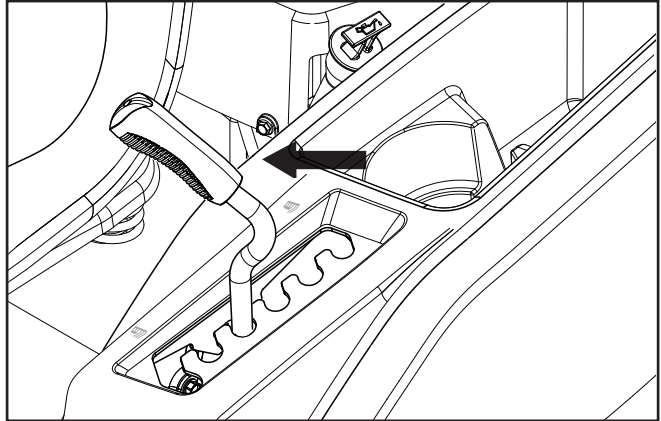

To set the deck cutting height, pull the cutting height lever inwards and move it to the desired height notch.

IMPORTANT INFORMATION Always raise the deck to the highest position for transport.

IMPORTANT INFORMATION To obtain an even cutting height, it is important that the air pressure in all tires is 15 psi / 103 kPa / 1 bar.

Bypass Linkages

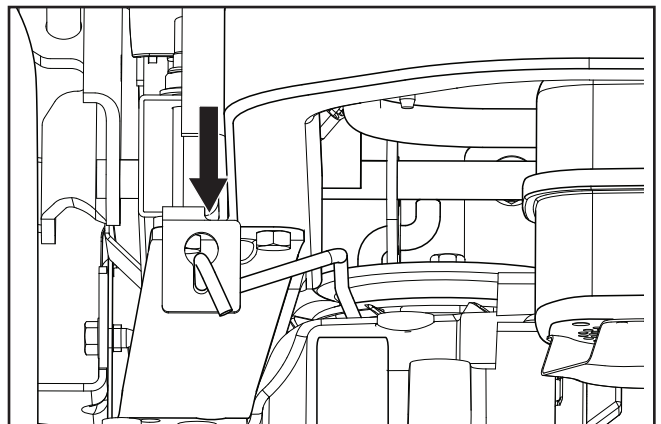

Transaxle bypass linkages must be engaged when pushing or pulling the mower. The release levers are located on each side of the rear of the unit below the rear engine guard. See **Moving Machine By Hand** in the *Operation* section.

WARNING! Bypass linkages are located close to the muffler. To prevent burns, the engine should be shut off and allowed to cool before the bypass linkage levers are handled.

CONTROLS

Fuel Tank

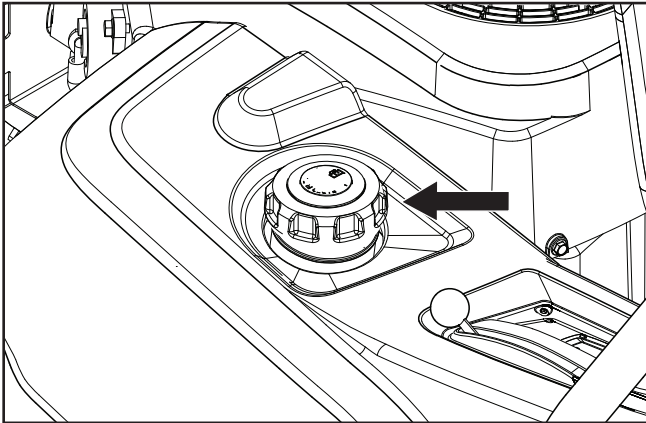

WARNING! Gasoline is highly flammable. Observe caution and fill the tank outdoors (see the safety instruction).

WARNING! The engine and the exhaust system become very hot during operation. There is a risk for burns if touched. Allow engine and exhaust system to cool before refueling.

WARNING! Fill to bottom of filler neck. Do not overfill. Wipe off any spilled oil or fuel. Do not store, spill or use gasoline near an open flame.

Read the safety instructions before refueling. The machine has one fuel tank, just behind the console. The tank capacity is 3½ gallons (13.25 litres).

Regularly check the gas cap gasket for damage and keep the cap properly tightened.

The engine will run on a minimum of 85-octane unleaded gasoline (no oil mix). Environmentally adapted alkylate gasoline can be used. See also *Technical Data* concerning ethanol fuel. Methanol fuel is not allowed. Do not use E85 alcohol based fuel. Damage to engine and components may occur.

When operating in temperatures below 32° F. (0° C.), use fresh, clean winter grade gasoline to insure good cold weather starting.

IMPORTANT INFORMATION Experience indicates that alcohol blended fuels (called gasohol, ethanol or methanol) can attract moisture which leads to separation and formation of acids during storage. Acidic gas can damage the fuel system of an engine while in storage. To avoid engine problems, the fuel system should be emptied before storage of 30 days or longer. Drain the gas tank, start the engine and let it run until the fuel lines and carburetor are empty. Use fresh fuel the next season. See **Storage** for additional information. Never use engine or carburetor cleaners in the fuel tank or permanent damage may occur.

Tracking

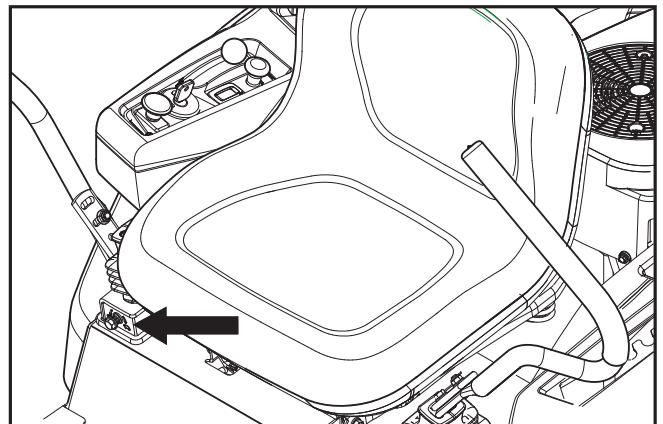

If the mower is not tracking straight, check the air pressure in both rear tires. Recommended air pressure for the rear tires is 15 psi (1 bar).

1. Tracking adjustments are made using the tracking bolts. The tracking bolts act as limiting devices for the motion control levers when in the full-forward position.
2. For preliminary tracking adjustment, move unit to an open, unobstructed area such as an empty parking lot or open field.
3. Using a ½" wrench, back the tracking bolts out until flush with nut.
4. Test operate unit by driving it at full throttle and the full forward position on both motion control levers. Gradually turn in the tracking bolt on the right hand side until the unit noticeably starts drifting right.
5. Drive forward at full throttle with both motion control levers in the full forward position. Gradually turn in the left tracking bolt until unit tracks straight.

OPERATION

Read the **Safety** section and following pages, if you are unfamiliar with the machine.

Training

Due to unique steering capabilities, zero turn mowers are far more maneuverable than typical riding mowers.

This section should be reviewed in its entirety prior to attempting to move the mower under its own power. When first operating the mower or until becoming comfortable with controls, use a reduced throttle speed and reduced ground speed. DO NOT move control levers to the furthest forward or reverse positions during initial operation.

First time users should become familiar with the mower's movement on a hard surface, such as concrete or blacktop PRIOR to attempting to operate on turf. Until the operator becomes comfortable with the mower controls and zero turning capability, overly aggressive maneuvers may damage turf.

Steering

To move forward and backward

The direction and speed of the mower's movements are effected by the movement of the control lever(s) on each side of mower. The left control lever controls the left wheel. The right control lever controls the right wheel.

First time users should push the mower (see **Moving the Machine By Hand** in the **Operation** section) to an open, flat area without other people, vehicles or obstacles nearby. To move the unit under its own power, the operator must sit in the seat and start the engine (see **Before Starting** in the **Operation** section). Adjust the engine speed to idle and disengage the park brake by moving the steering control levers inward. Do not engage the blades. As long as the control levers have not been moved forward or backwards, the mower will not move. Slowly move both control levers slightly forward. This will allow the mower to move forward in a straight line. Pull the control levers back to the neutral position and the mower should stop moving.

Pull back slightly on control levers, allowing the mower to move backwards. Push the control levers forward to the neutral position and mower should stop moving.

To turn to the right

While moving in a forward direction, pull the right lever back towards the neutral position while maintaining the position of the left lever, this will slow the rotation of the right wheel and cause the machine to turn in that direction.

To turn to the left

While moving in a forward direction pull the left lever back towards the neutral position while maintaining the position of the right lever, this will slow the rotation of the left wheel and cause the machine to turn in that direction.

To zero turn

While moving in a forward direction, first pull both control levers back until the mower stops or slows dramatically. Then by alternating one lever slightly to the forward position and the other in the reverse position, complete the turn.

Before Starting

1. Read the sections on **Safety** and **Controls** before starting the machine.
2. Perform the daily maintenance before starting (see **Maintenance Schedule** in the **Maintenance** section).
3. Check that there is sufficient fuel in the fuel tank.
4. Adjust the seat to the desired position.

The following conditions must be fulfilled before the engine can be started:

- The blade switch must be pressed down into the disengaged position.
- Both steering / park brake controls must be in the locked (outer) position.



WARNING! Engine exhaust and certain vehicle components contain or emit chemicals considered to cause cancer, birth defects or other reproductive system damage. The engine exhaust contains carbon monoxide, which is a odorless, colorless, poisonous gas. Do not use the machine in enclosed spaces.

Starting the Engine

1. Sit on the seat.
2. Raise the mower deck to the highest position.

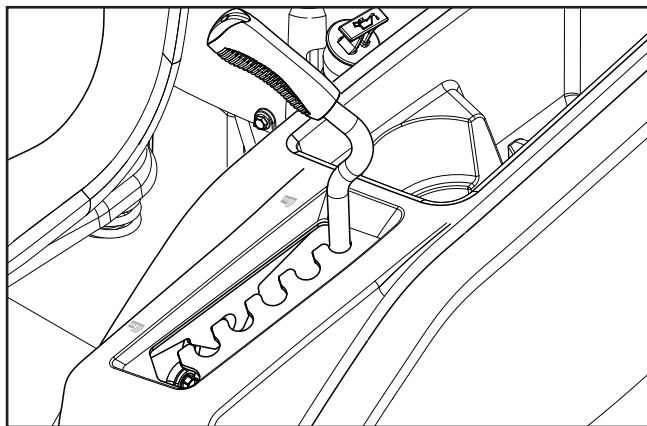

3. Disengage the mower blades by pressing the blade switch downwards.

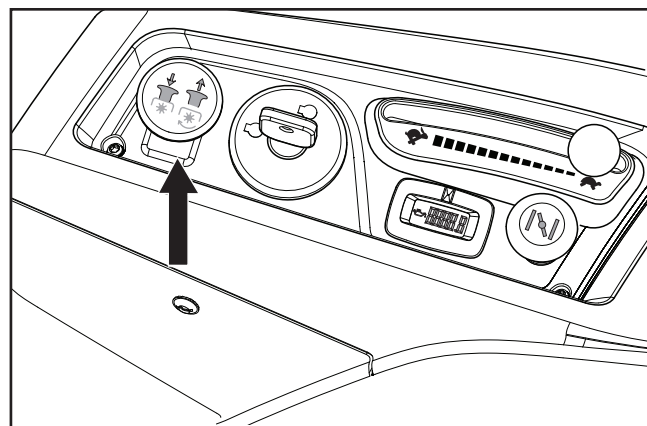

OPERATION

4. Move the steering / park brake controls out to the locked position.

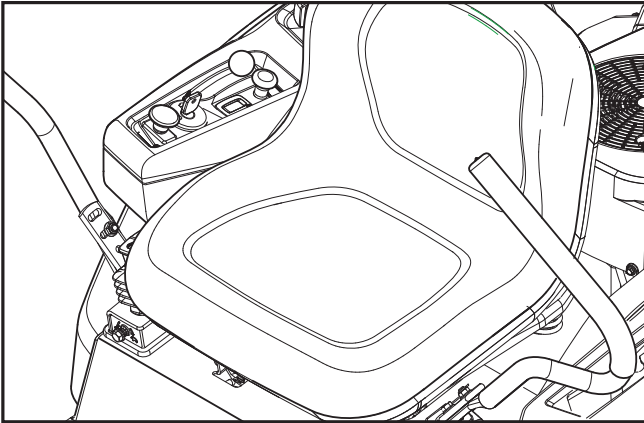

5. Move the throttle to the middle position. If the engine is cold, the choke control should be pulled up.

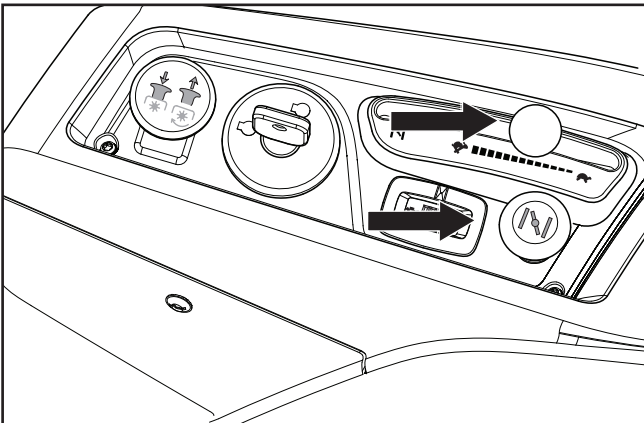

6. Press in and turn the ignition key to the start position.
7. When the engine starts, immediately release the ignition key back to the run position. Push the choke control in gradually when the engine has started.

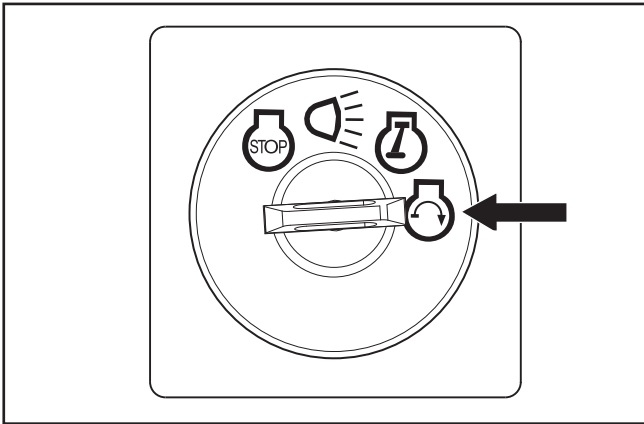

IMPORTANT INFORMATION Do not run the starter for more than 5 seconds each time. If the engine does not start, wait approximately 10 seconds before retrying.

8. Set the engine speed with the throttle. Allow the engine to run at a moderate speed, approximately mid throttle, for a short time before use.
9. **USE FULL THROTTLE WHEN MOWING.**

Running

1. Release the park brake by pulling the steering / park brake controls inwards to the neutral position.
NOTE: The mower is equipped with an operator presence system. When the engine is running, any attempt by the operator to leave the seat without first setting the park brake will shut off the engine.
2. Lower the mower deck to the desired cutting height.

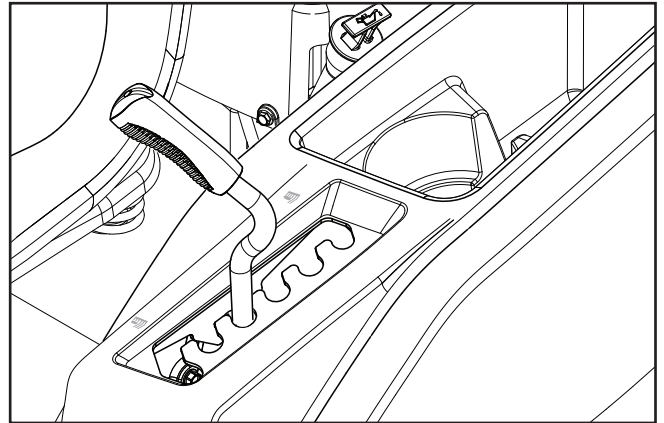

3. Move throttle control to full throttle (rabbit symbol).
4. Engage the mower deck by pulling the blade switch up.

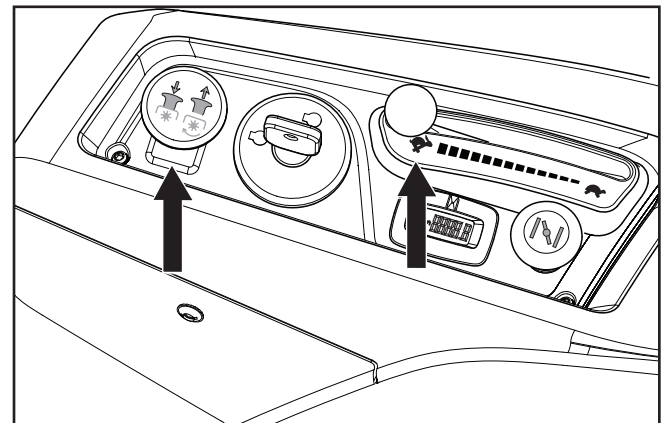

5. Rotate control levers inward and slowly move both control levers slightly forward to move forward in a straight line.

WARNING! Make sure that no one is near mower when engaging blade switch.

Make sure the work area is free from objects that could be thrown by the rotating blades.

WARNING! Do not drive up or down hills with slopes greater than 10 degrees. Do not drive across slopes.

OPERATION

Stopping the Engine

1. Move the throttle to the minimum position (tortoise symbol).
2. Move the steering / park brake controls outward from the neutral position.
3. Disengage the mower deck by pressing the blade switch down.

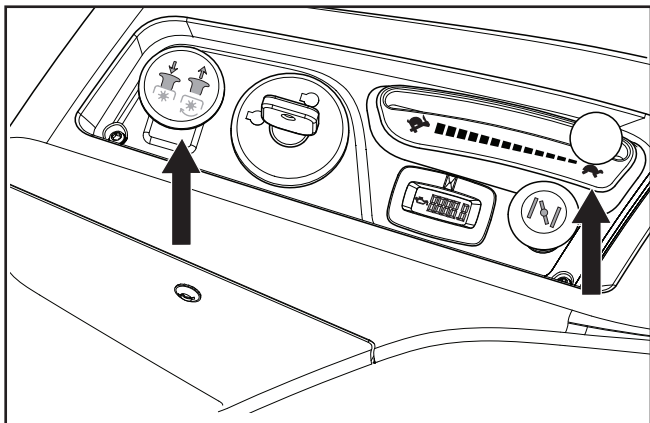

4. Raise the mower deck to the highest position. If the engine has been worked hard, allow it to idle at least 60 seconds to attain a normal operating temperature before stopping. To prevent fouling the spark plugs, avoid idling the engine for longer periods.
5. Turn the ignition key to the stop position. Remove key. Always remove key when leaving the mower to prevent unauthorized use.

IMPORTANT INFORMATION Leaving the ignition switch in any other position than OFF will cause the battery to be discharged.

Mowing Tips

- Observe and flag rocks and other fixed objects to avoid collisions.
- Begin with a high cutting height and reduce it until the desired mowing result is attained. The average lawn should be cut to 2½" during the cool season and over 3" during the hot months. For healthier and better looking lawns, mow often after moderate growth. For best cutting performance, grass over 6" in height should be mowed twice. Make the first cut relatively high, the second to the desired height.
- The mowing result will be best with a high engine speed (blades rotate rapidly) and low speed (rider moves slowly). If the grass is not too long and dense, the driving speed can be increased without negatively affecting the mowing result.
- The finest lawns are obtained by mowing often. The lawn becomes more even and the grass clippings more evenly distributed over the mown area. The total time taken is not increased as a higher operating speed can be used without poor mowing results.

- When mowing large areas, start by turning to the right so that clippings will discharge away from shrubs, fences, driveways, etc. After one or two rounds, mow in the opposite direction making left hand turns until finished.

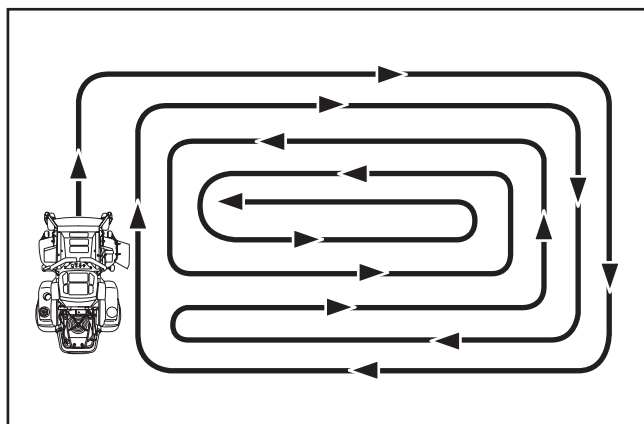

- Avoid mowing wet lawns. The mowing result is poorer because the wheels sink into the soft lawn, clumps build, and grass clippings fasten under the cowlings.
- Hose the mower deck underside with water after each use. When cleaning, the mower deck shall be raised into the transport position. Make sure the mower is cooled and the engine is off.
- Use compressed air to clean top surface of the deck. Avoid flooding water on top surface, engine and electrical components.
- When the mulching kit is used, it is important that the mowing interval is frequent.

Operating On Hills

Read the Safety Instructions *Driving on Slopes* in the *Safety* section.

- The slowest speed possible should be used before starting up or down hills.
- Avoid stopping or changing speed on hills.
- If stopping is absolutely necessary, pull steering controls into the neutral position and the push to the outside of the unit to engage the park brake.
- To restart movement, move the steering controls back to the neutral position.
- Press forward to regain forward motion.
- Make all turns slowly.

WARNING! Never drive the rider on terrain that slopes more than 10 degrees. Mow slopes up and down, never side to side. Avoid sudden directional changes.

OPERATION

Weak Battery

If the battery is too weak to start the engine, it should be recharged. (See **Battery** in the *Maintenance* section.)

If jumper cables are used for emergency starting, follow this procedure:

Jumper Cable Use

1. Connect each end of the RED cable to the POSITIVE (+) terminal on each battery, taking care not to short against chassis.
2. Connect one end of the BLACK cable to the NEGATIVE (-) terminal of the fully charged battery.
3. Connect the other end of the BLACK cable to a good CHASSIS GROUND on the mower with the discharged battery, away from the fuel tank and battery.

To remove cables, reverse order

1. Remove BLACK cable first from chassis and then from the fully charged battery.
2. Remove RED cable last from both batteries.

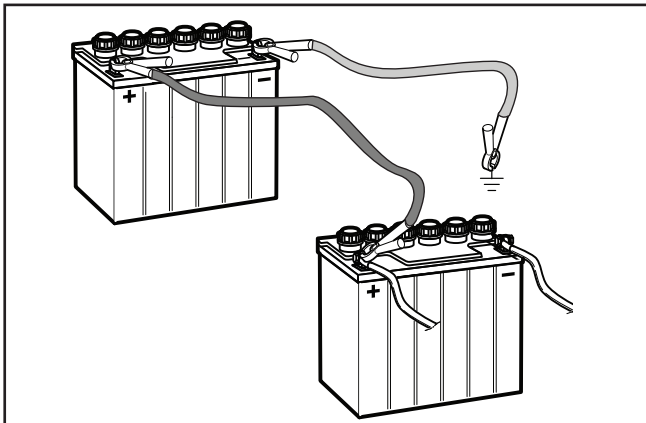

CAUTION! Lead-acid batteries generate explosive gases. Keep sparks, flame and smoking materials away from batteries. Always wear eye protection when around batteries.

IMPORTANT INFORMATION The mower is equipped with a 12-volt negative grounded system. The other vehicle must also be a 12-volt negative grounded system. Do not use your mower to start other vehicles.

Moving Machine By Hand

When pushing or pulling the mower, engage the EZT bypass linkages. The EZT bypass linkages are located on the rear of the frame, below the rear engine guard.

1. Raise the deck into the highest cutting position.
2. Move the steering / park brake controls inwards to the neutral position.
3. Pull the EZT bypass linkages up and out of the keyhole slots. Release the levers with the head outside the frame and held in the bypass position.
4. To reengage the EZT's to drive, reverse the above procedure.

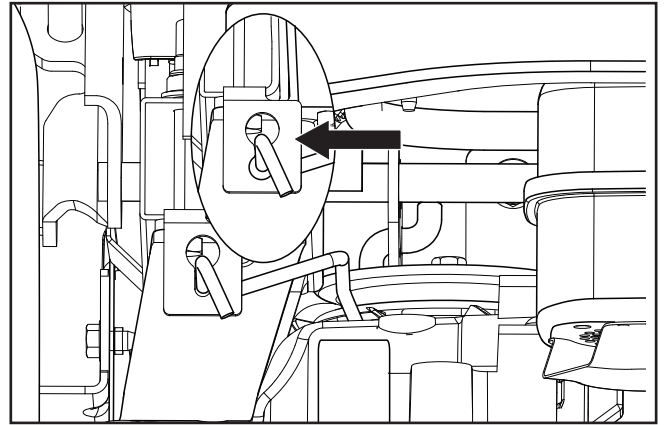

Load the machine into truck or trailer by driving slowly up the ramps. **DO NOT LIFT!** The machine is not intended to be lifted by hand.

WARNING! Bypass linkages are located close to the muffler. To prevent burns, the engine should be shut off and allowed to cool before the bypass linkage levers are handled.

WARNING! Make no adjustments without:

- the engine stopped,
- the ignition key removed,
- the park brake activated

WARNING! Use extreme caution when loading the machine into a truck or trailer using ramps. There is the possibility of serious injury or death if the machine falls off the ramps.

MAINTENANCE

Maintenance Schedule

The following is a list of maintenance procedures that must be performed on the machine. For those points not described in this manual, visit an authorized service workshop. An annual service carried out by an authorized service workshop is

recommended to maintain your machine in the best possible condition and to ensure safe operation.

Read **General Maintenance** in the **Safety** section.

MAINTENANCE	Daily		At least once each year	Maintenance interval in hours			
	Before	After		25	50	100	300
Check the park brake	●						
Check the engine's oil level (every refueling)	■						
Check the safety system	●						
Check for fuel and oil leakages	◆						
Check/clean the engine's cooling air intake		■					
Check the mower deck		●					
Check for loose hardware (screws, nuts)		●					
Clean under the mower deck		●					
Start the engine and blades, listen for unusual sounds		◆					
Check for damage		◆					
Thoroughly clean around the engine		◆					
Clean around belts, belt pulleys		◆					
Check the tire pressures				●			
Check battery connections				●			
Sharpen ³⁾ / Replace mower blades				●			
Clean the engine's cooling air intake ²⁾			■	■			
Clean the foam air cleaner prefilter ²⁾			■	■			
Clean the paper air cleaner filter cartridge ²⁾			■				
Check/adjust the park brake			◆		◆		
Inspect muffler/spark arrestor			◆		◆		

¹⁾ First change after 8-10 hours. When operating with a heavy load or at high ambient temperatures, replace every 50 hours.

²⁾ In dusty conditions, cleaning and replacement are required more often.

³⁾ Performed by authorized service workshop.

● = Described in this manual

◆ = Not described in this manual

■ = Refer to the engine manufacturer's manual

MAINTENANCE

MAINTENANCE	Daily		At least once each year	Maintenance interval in hours			
	Before	After		25	50	100	300
Check/adjust throttle cable						■	
Check the condition of belts, belt pulleys			●			●	
Change the engine oil ¹⁾			■		■		
Replace the engine oil filter			■			■	
Clean/replace the spark plugs			■			■	
Replace the fuel filter			■			■	
Replace paper air filter ²⁾			■			■	
Check the caster wheels (every 200 hours)			●			●	
Replace the air cleaner's foam pre-filter ²⁾			■				
Check/adjust the mower deck			●				●
Check the engine valve clearance ³⁾			◆				◆
Perform the 300-hour service ³⁾			◆				◆

¹⁾ First change after 8-10 hours. When operating with a heavy load or at high ambient temperatures, replace every 50 hours.

²⁾ In dusty conditions, cleaning and replacement are required more often.

³⁾ Performed by authorized service workshop.

● = Described in this manual

◆ = Not described in this manual

■ = Refer to the engine manufacturer's manual



WARNING! Before performing any service or adjustment checklist

- Engage the park brake.
- Place the blade switch in the disengaged position.
- Turn the ignition switch to OFF position and remove the key.
- Make sure the blades and all moving parts have completely stopped.



WARNING! Escaping hydraulic oil under pressure can have sufficient force to penetrate the skin, causing serious injury. If injured by escaping fluid, see a doctor at once. Serious infection or reaction can develop if proper medical treatment is not administered immediately.

MAINTENANCE

Battery

Your mower is equipped with a maintenance free battery that does not need servicing. However, periodic charging of the battery with an automotive type battery charger will extend its life.

- Keep battery and terminals clean.
- Keep battery bolts tight.
- See chart for charging times.

Cleaning battery and terminals

Corrosion and dirt on the battery and terminals can cause the battery to lose power.

1. Disconnect BLACK battery cable first, then the RED battery cable and remove the battery from the machine.
2. Rinse the battery with plain water and dry.
3. Clean terminals and battery cable ends with wire brush until shiny.
4. Coat terminals with grease or petroleum jelly.
5. Reinstall battery.

Replacing battery

1. Lift seat and rotate forward.
2. Using two ½" wrenches disconnect BLACK battery cable then RED battery cable.
3. Position deck to lowest setting.
4. Front underside of frame, remove the nuts that secure the battery hold-down.

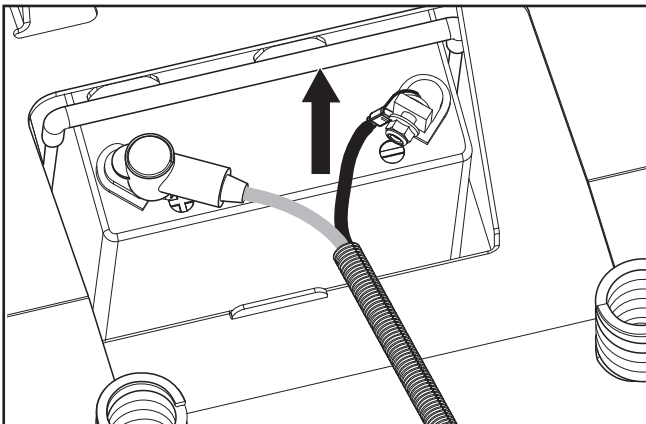

5. Carefully remove the battery from the mower.
6. Install new battery with cable terminals routed toward the center of the battery.
7. Reinstall battery hold-down and secure with nuts removed in Step 4.
8. Reconnect RED battery cable to positive (+) battery terminal with bolt and hex nut.
9. Connect BLACK grounding cable to negative (-) battery terminal with remaining hex bolt and hex nut
10. Replace terminal boot cover.
11. Lower seat

STANDARD BATTERY	STATE OF CHARGE	APPROXIMATE BATTERY CHARGING TIME* TO FULL CHARGE AT 80°F / 27°C			
		Maximum Rate at:			
		50 Amps	30 Amps	20 Amps	10 Amps
12.6V	100%	- FULL CHARGE -			
12.4V	75%	20 min.	35 min.	48 min.	90 min.
12.2V	50%	45 min.	75 min.	95 min.	180 min.
12.0V	25%	65 min.	115 min.	145 min.	280 min.
11.8V	0%	85 min.	150 min.	195 min.	370 min.

*Charging time depends on battery capacity, condition, age, temperature and efficiency of charger



WARNING! Do not short battery terminals by allowing a wrench or any other object to contact both terminals at the same time. Before connecting battery, remove metal bracelets, wristwatch bands, rings, etc. Positive terminal must be connected first to prevent sparks from accidental grounding.

IMPORTANT INFORMATION Do not attempt to open or remove caps or covers. Adding or checking level of electrolyte is not necessary.

Always use two wrenches for the terminal screws.



CAUTION! Always wear eye protection when around batteries.

MAINTENANCE

Safety System

The machine is equipped with a safety system that prevents starting or driving under the following conditions.

The engine can only be started when:

- the mower deck is disengaged.
- the steering / park brake controls are in the outer, locked neutral position.

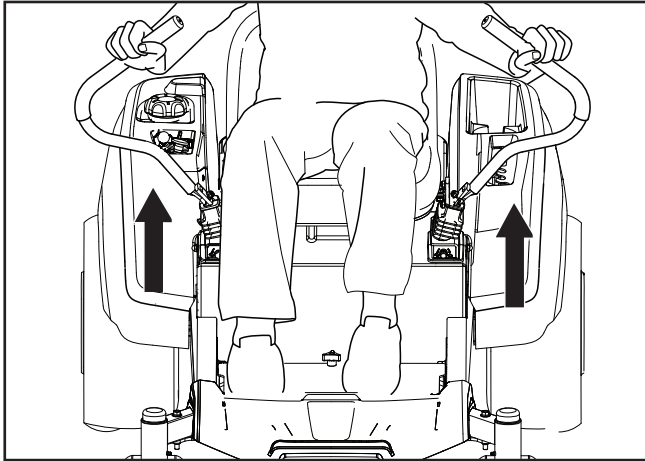

Make daily inspections to ensure that the safety system works by attempting to start the engine when one of the conditions is not met. Change the conditions and try again.

If the machine starts when one of these conditions is not met, turn the machine off and repair the safety system before using the machine again.

Make sure the engine stops when the park brake is not engaged and the operator leaves the seated position.

Check that the engine stops if the mower blades are engaged and the driver temporarily moves off the drivers seat.

IMPORTANT INFORMATION To be able to drive, the driver must sit in the seat and the steering / park brake controls must be moved into the engaged (outer) position. Otherwise the engine will stop.

Park Brake

Visually check that no damage is found on the steering control levers, links or switches belonging to the park brake. Perform a standstill test and check that there is sufficient braking action.

To adjust the park brake, contact the Husqvarna service workshop.

IMPORTANT INFORMATION The machine must be absolutely standing still when applying the park brake.

WARNING! Faulty adjustment will result in reduced braking ability and can cause an accident.

Tire Pressures

All tires should be at 15 psi / 103 kPa / 1 bar.

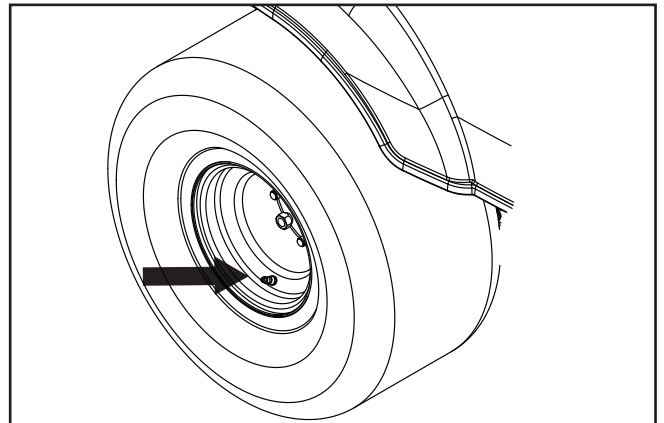

IMPORTANT INFORMATION DO NOT add any type of tire liner or foam fill material to the tires. Excessive loads created by foam filled tires will cause premature failures. Only use O.E.M. specified tires.

MAINTENANCE

Caster Wheels

Check every 200 hours. Check that wheels rotate freely. If wheels do not rotate freely take the unit to your dealer for service.

Foam filled tires or solid tires will void the warranty.

Removal and installation

Remove nut and caster bolt. Pull the wheel out of the yoke and take care of the spacers. Install in reverse order. Tighten caster bolt.

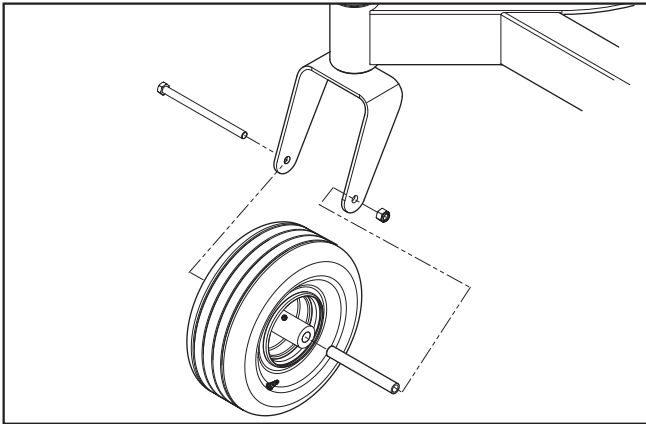

Anti-scalp Rollers

Anti-scalp rollers are properly adjusted when they are just slightly off of the ground when the deck is at the desired cutting height in the operating position. Anti-scalp rollers then keep the deck in the proper position to help prevent scalping in most terrain conditions.

The anti-scalp rollers can be set in three positions:

- Upper position 1½" to 2½" (38 to 64 mm) grass
- Middle position 2½" to 4" (64 to 102 mm) grass
- Lower position 4" to 6" (102 to 128) mm grass.

The rollers should be approximately ¼" (6.5 mm) from the ground.

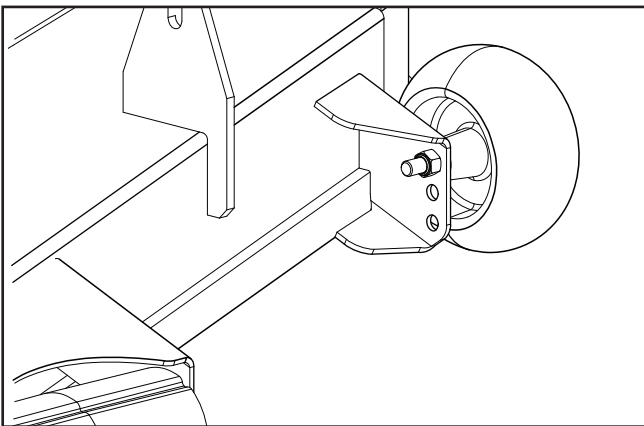

IMPORTANT INFORMATION Adjust anti-scalp rollers with the mower on a flat level surface.

To avoid deck damage, the anti-scalp rollers must not be adjusted to support the deck.

V-belts

Check every 100 hours of operation. Check for severe cracking and large nicks.

NOTE: The belt will show some small cracks in normal operation.

The belts are not adjustable. Replace belts if they begin to slip from wear.

Deck Belt Removal

1. Park on a level surface. Apply parking brake.
2. Lower the deck into the lowest cutting position.
3. Remove bolts from belt shields and remove shields.
4. Remove any dirt or grass that may have accumulated around the cutter housings and entire deck surface.
5. Remove tension on the belt by moving the idler arm.
6. Carefully lift the belt up over the top of the cutter housing pulleys and remove belt. Rolling belt over the pulleys may damage the belt.

Deck Belt Installation

NOTE: For ease in installing the deck belt, refer to the routing decal on the top of the deck.

1. Wrap the deck belt around the electric clutch pulley that is located on the engine shaft.
2. Route the belt forward and up onto the deck.
3. Place belt around spring loaded idler pulley.

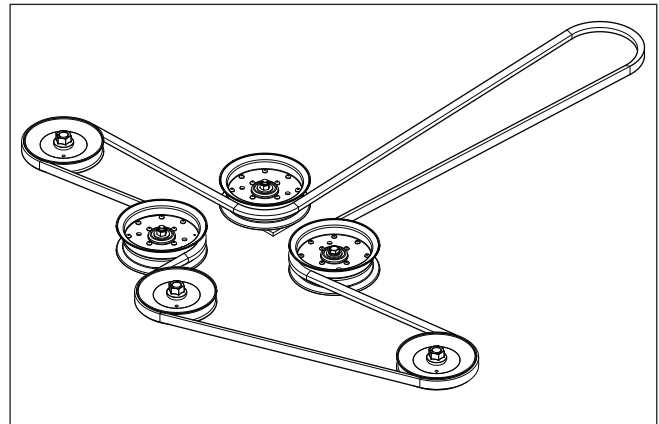

4. Wrap the belt around the stationary idler pulley and around the mandrel housings.
5. Push inward on the idler arm and carefully route belt over stationary idler pulley. Once belt is properly routed, slowly release idler arm to tension belt.
6. Double check belt routing to make sure it matches the routing decal and the belt does not have any twist. Correct as needed.
7. Replace belt shields on both mandrel housings and secure with fasteners.

MAINTENANCE

Adjusting the Mower Deck

Leveling deck

Adjust the deck while the mower is on a level surface. Make sure the tires are inflated to the correct pressure. See **Technical Data** / Transmission. If tires are under or over inflated, the deck cannot be properly adjusted. Raise the deck to the highest (transport) position.

The deck should be adjusted slightly higher in the rear.

NOTE: To insure accuracy of leveling procedure, mower deck drive belt must be installed prior to leveling deck.

1. Wear heavy gloves. Turn each outer blade tip to align front to rear with the deck side-to-side.

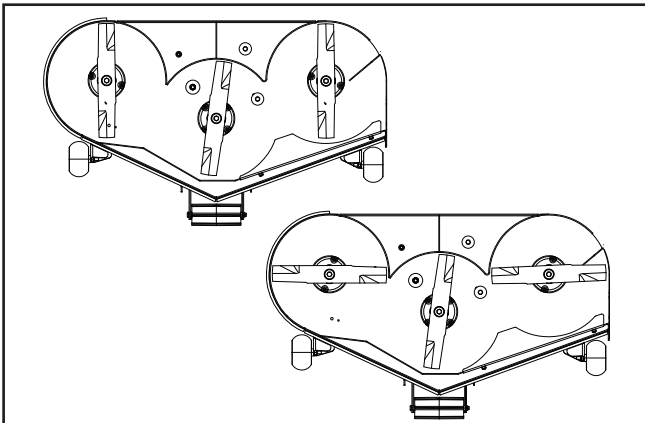

2. Measure from the floor surface up to the bottom of the blade tip on the discharge side of the mower deck. Record the measurement.
3. Move to the opposite side, check that measurement is the same. If adjustment is required—with a $\frac{3}{4}$ " or adjustable wrench, turn the lift link adjustment nuts on either side counter clockwise to lower or clockwise to raise. Adjust until both measurements are equal.

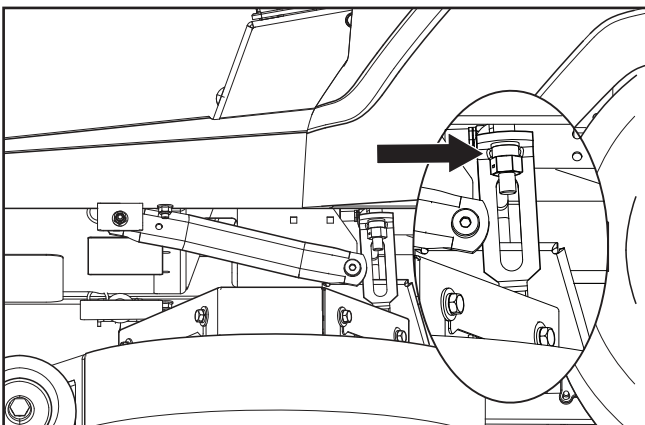

4. Turn any blade to align with the deck front-to-rear. If the front blade tip does not measure $\frac{1}{8}$ " to $\frac{1}{2}$ " higher in the rear—with a $\frac{5}{8}$ " or adjustable wrench, turn the nuts on the front suspension linkage. Clockwise raises the front of the mower, counter clockwise will lower the front. Adjust nuts until rear of mower deck is positioned level to $\frac{1}{8}$ " higher in the rear than the side-to-side measurement.

NOTE: For illustration, the front foot rest has been removed. The adjustment can be made without removal.

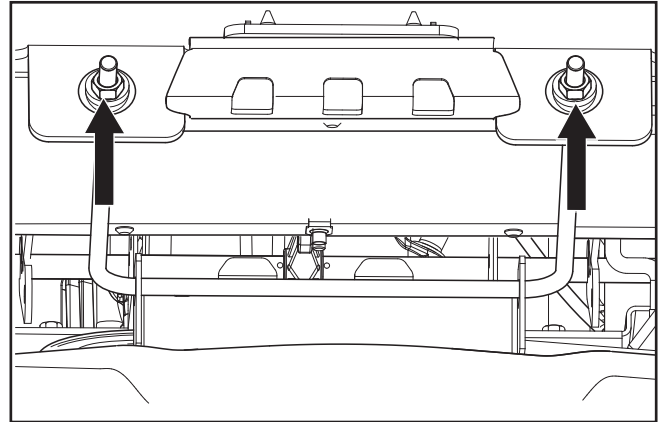

NOTE: This will place the mower deck in a standard measurement position. Depending on the type of grass being mowed or environmental conditions, additional adjustments may be required to achieve the desired cut.

MAINTENANCE

Cutting Blades

For the best mowing results, it is important that blades are well sharpened and not damaged.

Replace blades that have been bent or cracked by hitting obstacles.

Let the service workshop decide whether a blade with large nicks can be repaired/ground or must be replaced. Balance the blades after sharpening.

Check the blade mounts.



CAUTION! Blades are sharp. Protect your hands with gloves and/or wrap blades with a heavy cloth when handling.

The sharpening of blades should be carried out by an authorized service workshop.

Blade replacement

1. Remove blade bolt by turning counter clockwise.
2. Install new or resharpened blade with stamped **GRASS SIDE** facing towards ground/grass (down) or **THIS SIDE UP** facing deck and cutter housing.
3. Seat the blade's opening firmly onto the cutter housing.
4. Tighten blade bolt securely.
5. Torque blade bolt to 45-60 ft/lbs (60-81 Nm).

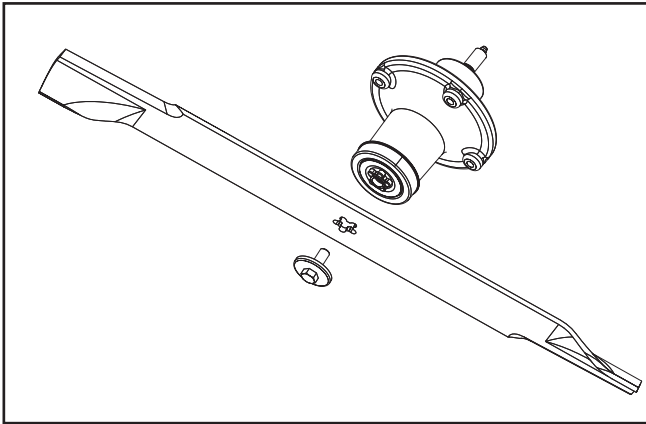

IMPORTANT INFORMATION The special blade bolt is heat treated. Replace with a Husqvarna bolt if required. Do not use lower grade hardware than specified.

Cleaning

Regular cleaning, especially under the mower deck, will increase the machine's life-span. Make it a habit to clean the machine directly after use (after it is cooled), before the debris sticks.

Do not spray water on the top of the mower deck. Use compressed air to clean the top side of mower deck. Regularly clean the underside of the deck with normal water pressure. Do not use a high pressure washer or steam cleaner. Avoid spraying the engine and electrical components with water.

For models fitted with a cleanout port, attach the quick connect (from the accessory packet) to any garden hose. After mowing, snap the hose to the cleanout port and turn on water supply.

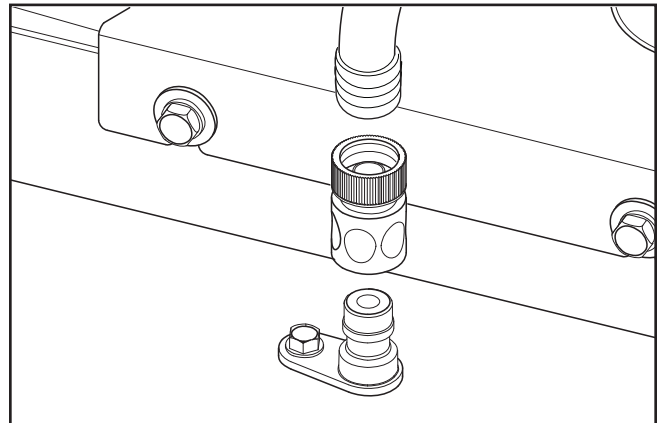

Restart the mower and engage the blades to use the spinning action to wash away debris. Make sure the hose is away from the mower blades.

Do not rinse hot surfaces with cold water. Let unit cool before washing.



CAUTION! Use protective glasses when cleaning and washing.

Hardware

Check daily. Inspect the entire machine for loose or missing hardware.

LUBRICATION

12/12	1/52	1/365		25h	50h	100h	200h	300h
				1 (2x)				
				2 (2x)				
				3				
				4 (2x)				
			5					
				*				

12/12	Every year	Lubricate with grease gun	
1/52	Every Week	Filter change	
1/365	Every day	Oil change	
		Level check	

General

Remove the ignition key to prevent unintentional movements during lubrication.

When lubricating with an oil can, it must be filled with engine oil.

When lubricating with grease, unless otherwise stated, use a high grade molybdenum disulphide grease.

For daily use, the machine should be lubricated twice weekly. Wipe away excess grease after lubrication.

It is important to avoid getting lubricant on the belts or the drive surfaces of the belt pulleys. Should this happen, attempt to clean them with spirits. If the belt continues to slip after cleaning, the belt must be replaced. Gasoline or other petroleum products must not be used to clean belts.

IMPORTANT INFORMATION Use minimal lubrication and remove excess lubricant so that it does not come into contact with belts or belt pulley drive surfaces.

Transmission

The transmission is maintenance free with no need for level checks or oil changes. If a leak occurs, replace the unit or contact your Husqvarna dealer.

Wheel and Deck Zerk

Use only good quality bearing grease.

Grease from well-known brand names (petrochemical companies, etc.) usually maintains a good quality.

Front Wheel Mount

Lubricate 3-4 strokes with a grease gun on each set of wheel bearings.

Front Wheel Bearings

Lubricate 3-4 strokes with a grease gun on each set of wheel bearings.

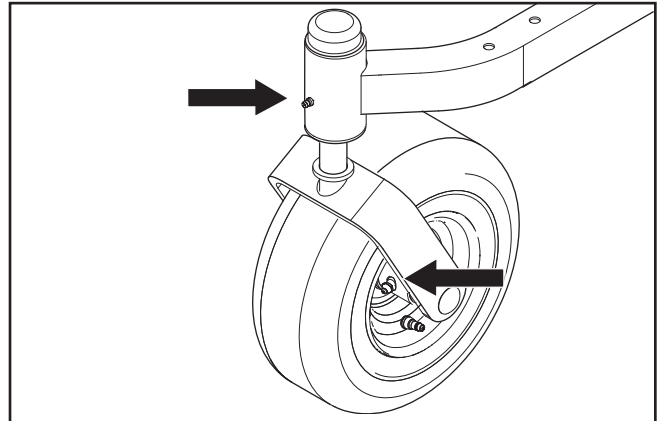

Deck Spindles

Lower the cutting deck completely. Lubricate with a grease gun, 2-3 strokes per spindle through the openings in the belt shields.

If a grease gun without rubber hose is used, the foot plate must be removed to access the center spindle.

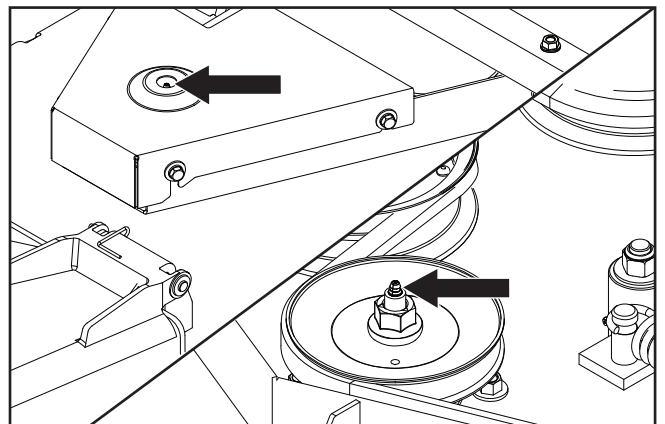

TROUBLESHOOTING

Problem / Cause

Engine will not start

- Blade switch is engaged
- Steering controls are not locked in the outer position
- Battery is dead
- Contamination in the carburetor or fuel line
- Fuel supply shutoff valve is closed
- Clogged fuel filter or fuel line
- Ignition system faulty

Starter does not turn the engine over

- Battery is dead
- Poor contact of the battery terminal cable connections
- Blown fuse
- Fault in the starter safety circuit. See **Safety System** in the *Maintenance* Section
- Safety switches are not fully inserted

Engine runs rough

- Faulty carburetor
- Clogged fuel filter or jet
- Choke control is pulled out with a warm engine
- Clogged ventilation valve on the fuel cap
- Fuel tank nearly empty
- Fouled spark plugs
- Rich fuel mixture or fuel-air mixture.
- Wrong fuel type
- Water in fuel
- Clogged air filter

Engine seems weak

- Clogged air filter
- Fouled spark plugs
- Carburetor incorrectly adjusted
- Air trapped in hydraulic system

Machine vibrates

- Blades are loose
- Blades are incorrectly balanced
- Engine is loose

Engine overheats

- Clogged air intake or cooling fins
- Engine overloaded
- Poor ventilation around engine
- Defective engine speed regulator
- Too little or no oil in the engine
- Contamination in the carburetor or fuel line
- Fouled spark plugs

Battery not charging

- Poor contact of the battery terminal cable connections
- Charging lead is disconnected

Machine moves slowly, unevenly, or not at all

- Park brake on
- Bypass valve on pump open
- Drive belt for the transmission is slack or has come off
- Air trapped in hydraulic system

Mower deck not engaging

- Drive belt for the mower deck has come loose
- Contact for the electromagnetic coupling has loosened
- Blade switch is faulty or has come loose from cable contact
- Blown fuse

Transaxle leaks oil

- Damaged seals, housing, or gaskets
- Air trapped in hydraulic system

Uneven mowing results

- Different air pressure in tires on the left and right sides.
- Bent blades
- Suspending for the mower deck is uneven
- Blades are dull
- Driving speed too high
- Grass is too long
- Grass collected under the mower deck

STORAGE

Winter Storage

The machine should be readied for storage at the end of the mowing season or if it will not be in use for more than 30 days. Fuel allowed to stand for long periods of time (30 days or more) can leave sticky residues that can plug the carburetor and disrupt engine function.

Fuel stabilizers are an acceptable option to prevent the sticky residues that can occur during storage.

Add stabilizer to the fuel in the tank or in the storage container. Always use the mixing ratios specified by the stabilizer manufacturer. Run the engine for at least ten minutes after adding the stabilizer so that it reaches the carburetor. Do not empty the fuel tank and the carburetor if stabilizer has been added.



WARNING! Never store an engine with fuel in the tank indoors or in poorly ventilated spaces where fuel vapor can come in contact with open flames, sparks, or a pilot light such as in a boiler, hot water tank, clothes dryer, etc. Handle the fuel with care. It is very flammable and can cause serious personal injury and property damage. Drain the fuel into an approved container outdoors and store far away from open flame or sources of ignition. Never use gasoline for cleaning. Use a degreaser and warm water.

To ready the machine for storage:

1. Thoroughly clean the machine, especially under the mower deck. Touch up damage to the paint and spray a thin layer of oil on the underside of the mower deck to avoid corrosion.
2. Inspect the machine for worn or damaged parts and tighten any nuts or screws that may have become loose.
3. Change the engine oil; dispose of properly.
4. Empty the fuel tanks or add a fuel stabilizer. Start the engine and allow it to run until the carburetor is drained of fuel or the stabilizer has reached the carburetor.
5. Remove the spark plug and pour about a tablespoon of engine oil into the cylinder. Turn over the engine so that the oil is evenly distributed and then refit the spark plug.
6. Lubricate all grease zerks, joints and axles.
7. Remove the battery. Clean, charge and store the battery in a cool place, but protect it from direct cold.
8. Store the machine in a clean, dry place and cover it for extra protection.

Service

When ordering spare parts, please specify the purchase year, model, type, and serial number.

Always use genuine Husqvarna spare parts.

An annual check-up at an authorized service workshop is a good way to ensure that the machine performs its best the following season.

SCHEMATIC

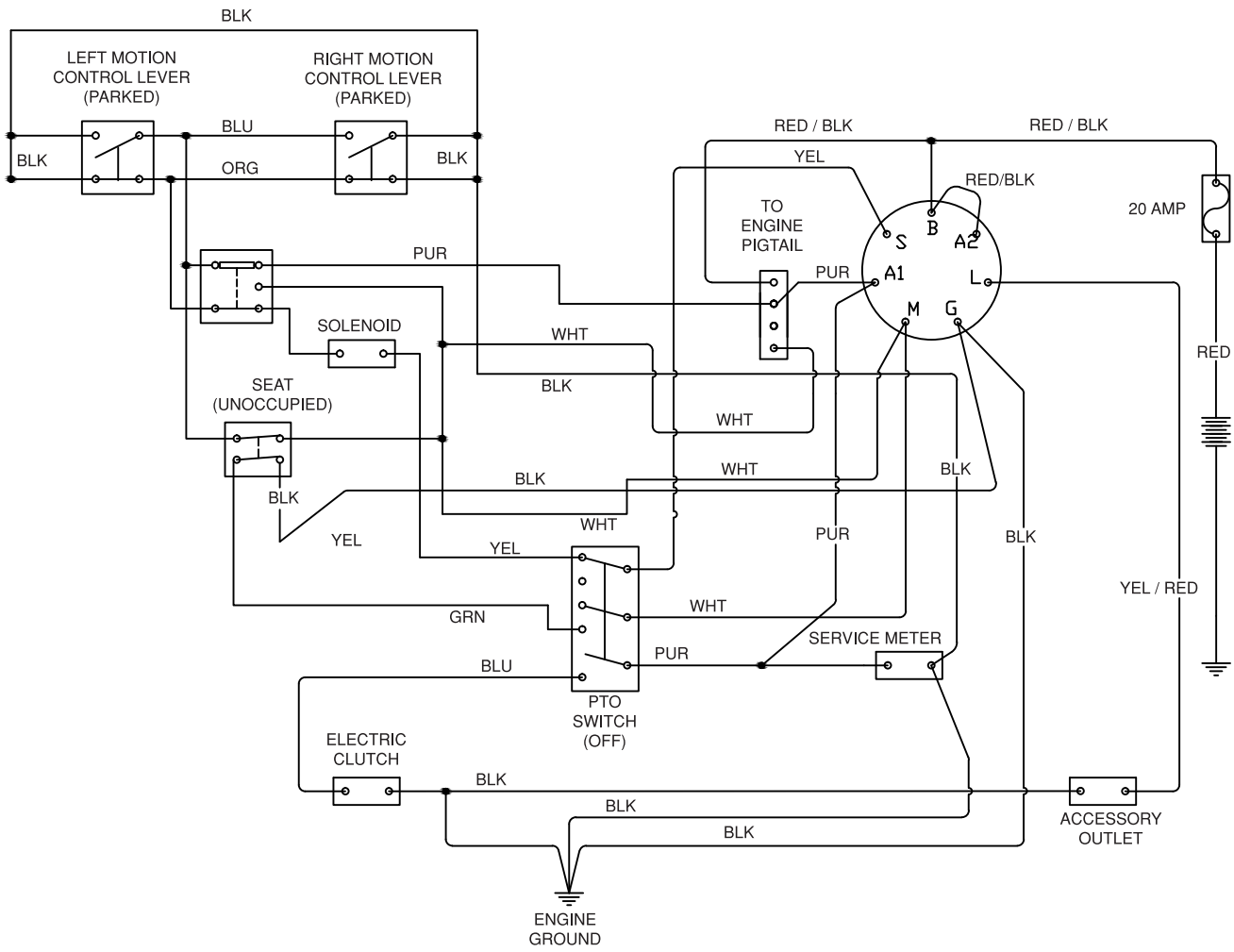

KEY SWITCH POSITIONS

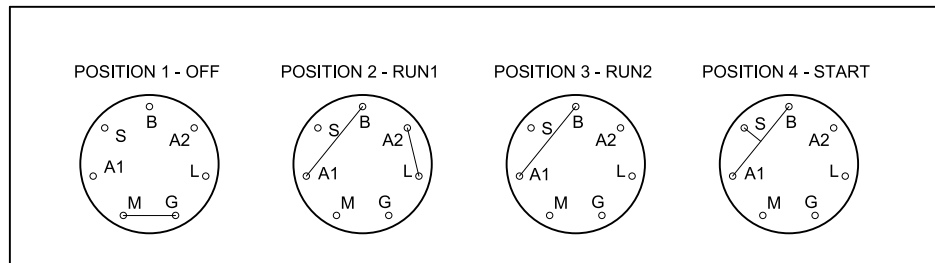

TECHNICAL DATA

Engine		Frame	
Manufacturer	Briggs & Stratton	Cutting Width	48" / 122 cm
Type	Endurance	Cutting Height	1½" - 4" / 3.8 - 10.2 cm
Power	24 ¹⁾	Uncut Circle	0
Lubrication	Pressure with oil filter	Number of Blades	3
Fuel	Min 87 octane unleaded (Max ethanol 10%, Max MTBE 15%)	Blade Length	16¼" / 42 cm
Fuel tank capacity	3½ gallons / 13.25 litres	Anti-scalp Rollers	2
Cooling	Air cooled	Sprung Seat	Standard
Air filter	Standard	Hinged Arm Rests	Optional
Alternator	12V	Service Meter	Digital
Starter	Electric	Blade Engagement	Electromagnetic Clutch
Transmission		Deck Construction	11 gauge fabricated
Transmission	Hydrostatic transaxles	Productivity	2.5 acres/h / 10117.1 m ² /h
Steering control	Dual levers, foam gripped	Dimensions	
Speed forward	0-6.5 mph / 0-10.5 km/h	Weight	595 lbs / 270 kg
Speed reverse	0-3.5 mph / 0-5.6 km/h	Base Machine Length	75" / 191 cm
Brakes	Mechanical park brake	Base Machine Height	40" / 102 cm
Front caster tires	11 x 6-5	Base Machine Width	43¾" / 111 cm
Rear tires, turf pneumatic	18 x 9.5-8	Overall Width, Chute Up	48½" / 123 cm
Tire pressure	15 PSI / 103 kPa / 1 bar	Overall Width, Chute Down	59¾" / 152 cm

¹⁾ *The power rating as declared by the engine manufacturer is the average gross power output at the specified RPM of a typical production engine for the engine model measured using SAE Standards for engine gross power. Refer to the engine manufacturer engine specifications.*

TECHNICAL DATA

Torque Specifications

Engine crankshaft bolt	75 ft/lb (102 Nm)	Standard 1/4" fasteners	9 ft/lb (12 Nm)
Deck pulley bolts	75 ft/lb (102 Nm)	Standard 5/16" fasteners	18 ft/lb (25 Nm)
Lug nuts	75 ft/lb (102 Nm)	Standard 3/8" fasteners	33 ft/lb (44 Nm)
Blade bolt	60 ft/lb (81 Nm)	Standard 7/16" fasteners	52 ft/lb (70 Nm)
		Standard 1/2" fasteners	80 ft/lb (110 Nm)

Accessories

Collection system

HEX HEAD CAP SCREWS

The torque values shown should be used as a general guideline when specific torque values are not given.

U.S. Standard Hardware

Grade		SAE Grade 5		SAE Grade 8		Flangelock Screw w/Flangelock Nut	
Size		ft./lbs	Nm	ft./lbs	Nm	ft./lbs	Nm
Shank Size (Diameter in inches, fine or coarse thread)	1/4	9	12	13	18		
	5/16	18	24	28	38	24	33
	3/8	31	42	46	62	40	54
	7/16	50	68	75	102		
	1/2	75	102	115	156		
	9/16	110	149	165	224		
	5/8	150	203	225	305		
	3/4	250	339	370	502		
	7/8	378	512	591	801		
	1 1/8	782	1060	1410	1912		

** Grade 5 - Minimum commercial quality (lower quality not recommended)

Metric Standard Hardware

Grade		Grade 8.8		Grade 10.9		Grade 12.9	
Size		ft./lbs	Nm	ft./lbs	Nm	ft./lbs	Nm
Shank Size (Diameter in inches, fine or coarse thread)	M4	1.5	2	2.2	3	2.7	3.7
	M5	3	4	4.5	6	5.2	7
	M6	5.2	7	7.5	10	8.2	11
	M7	8.2	11	12	16	15	20
	M8	13.5	18	18.8	25	21.8	30
	M10	24	33	35.2	48	43.5	59
	M12	43.5	59	62.2	84	75	102
	M14	70.5	96	100	136	119	161
	M16	108	146	147	199	176	239
	M18	142	193	202	274	242	328
	M20	195	264	275	373	330	447
	M22	276	374	390	529	471	639
	M24	353	478	498	675	596	808
M27	530	719	735	996	904	1226	

SERVICE JOURNAL

Action	Date, mtr reading, stamp, sign
Delivery Service	
Charge the battery	<input type="checkbox"/>
Adjust the tire pressure of all wheels to 15 PSI (1 bar)	<input type="checkbox"/>
Mount the steering controls in the normal position	<input type="checkbox"/>
Connect the contact box to the cable for the seat's safety switch	<input type="checkbox"/>
Check that the right amount of oil is in the engine	<input type="checkbox"/>
Adjust the position of the steering controls	<input type="checkbox"/>
Fill with fuel and open the fuel shut off valve	<input type="checkbox"/>
Start the engine	<input type="checkbox"/>
Check that there is drive to both wheels	<input type="checkbox"/>
Check the mower deck adjustment	<input type="checkbox"/>
Check:	
Safety switch for the park brake	<input type="checkbox"/>
Safety switch for the mower deck	<input type="checkbox"/>
Safety switch in the seat	<input type="checkbox"/>
Safety switch in the steering controls	<input type="checkbox"/>
Park brake functionality	<input type="checkbox"/>
Driving forward	<input type="checkbox"/>
Driving backward	<input type="checkbox"/>
Engaging the blades	<input type="checkbox"/>
Check the idle speed	<input type="checkbox"/>
Check the engine high idle speed	<input type="checkbox"/>
Inform the customer about:	
Need and advantages of following the service schedule	<input type="checkbox"/>
Need and advantages of leaving machine for service every 300 hours	<input type="checkbox"/>
Effects of service and maintaining a service journal on machine's resale value	<input type="checkbox"/>
Application areas for mulching	<input type="checkbox"/>
Fill in the sales papers, etc.	
Delivery service has been carried out No remaining notes Certified:	

SERVICE JOURNAL

Action	Date, mtr reading, stamp, sign
<p>After the First 10 Hours Change engine oil</p>	<input type="checkbox"/>
	Date, mtr reading, stamp, sign
<p>25-Hour Service Check the fuel pump's air filter Sharpen/Replace mower blades if required Check the tire pressures Check battery cables Lubricate according to lubrication chart Check / clean the engine's cooling air intake Clean the air cleaner's foam pre-filter</p>	<input type="checkbox"/> <input type="checkbox"/> <input type="checkbox"/> <input type="checkbox"/> <input type="checkbox"/> <input type="checkbox"/> <input type="checkbox"/>
	Date, mtr reading, stamp, sign
<p>50-Hour Service Perform the 25-hour service Clean / replace the air cleaner's paper filter cartridge (shorter intervals for dusty operating conditions) Change engine oil Lubricate according to lubrication chart Check/adjust the park brake</p>	<input type="checkbox"/> <input type="checkbox"/> <input type="checkbox"/> <input type="checkbox"/> <input type="checkbox"/>

SERVICE JOURNAL

Action	Date, mtr reading, stamp, sign
<p>100-Hour Service</p> <p>Perform the 25-hour service</p> <p>Perform the 50-hour service</p> <p>Change the engine oil filter</p> <p>Clean/replace the spark plugs</p> <p>Replace the fuel filter</p> <p>Check V-belts</p> <p>Check / tighten caster wheel axle bolts (every 200 hours)</p> <p>Change the air filter's paper cartridge</p> <p>Change hydraulic pump oil and filter. (200 hours)</p>	<p><input type="checkbox"/></p> <p><input type="checkbox"/></p> <p><input type="checkbox"/></p> <p><input type="checkbox"/></p> <p><input type="checkbox"/></p> <p><input type="checkbox"/></p> <p><input type="checkbox"/></p> <p><input type="checkbox"/></p> <p><input type="checkbox"/></p>

Action	Date, mtr reading, stamp, sign
<p>300-Hour Service</p> <p>Perform the 25-hour service</p> <p>Perform the 50-hour service</p> <p>Perform the 100-hour service</p> <p>Check / adjust the mower deck</p> <p>Clean the combustion chamber and grind the valve seats</p> <p>Check the engine valve clearance</p> <p>Replace the air cleaner's foam pre-filter</p>	<p><input type="checkbox"/></p> <p><input type="checkbox"/></p> <p><input type="checkbox"/></p> <p><input type="checkbox"/></p> <p><input type="checkbox"/></p> <p><input type="checkbox"/></p> <p><input type="checkbox"/></p>

SERVICE JOURNAL

Action	Date, mtr reading, stamp, sign
<p>At Least Once Each Year</p> <p>Clean the engine's cooling air intake (25 hours)</p> <p>Replace the air cleaner's foam pre-filter (300 hours)</p> <p>Replace the air filter's paper cartridge</p> <p>Change the engine oil (50 hours)</p> <p>Replace the engine oil filter (100 hours)</p> <p>Check / adjust the cutting height</p> <p>Check / adjust the park brake (50 hours)</p> <p>Clean / change the spark plugs (100 hours)</p> <p>Change the fuel filter (100 hours)</p> <p>Check the engine valve clearance</p>	<p><input type="checkbox"/></p> <p><input type="checkbox"/></p> <p><input type="checkbox"/></p> <p><input type="checkbox"/></p> <p><input type="checkbox"/></p> <p><input type="checkbox"/></p> <p><input type="checkbox"/></p> <p><input type="checkbox"/></p> <p><input type="checkbox"/></p> <p><input type="checkbox"/></p>

www.husqvarna.com

115 68 47-27 Rev B
2014-08-15