

EasyCut 400/25

Art. 9807

D Betriebsanleitung
Turbotrimmer

GB Operating Instructions
Turbotrimmer

F Mode d'emploi
Coupe-bordures

NL Gebruiksaanwijzing
Turbotrimmer

S Bruksanvisning
Turbotrimmer

DK Brugsanvisning
Turbotrimmer

FI Käyttöohje
Turbotrimmeri

N Bruksanvisning
Turbotrimmer

I Istruzioni per l'uso
Turbotrimmer

E Instrucciones de empleo
Recortabordes

P Manual de instruções
Aparador de relva Turbotrimmer

PL Instrukcja obsługi
Podkaszarka

H Használati utasítás
Damilos fűszegélynyíró

CZ Návod k obsluze
Turbotrimmer

SK Návod na obsluhu
Turbotrimmer

GR Οδηγίες χρήσης
Κουρευτικό πετονιάς

RUS Инструкция по эксплуатации
Турботриммер

SLO Navodilo za uporabo
Turbo obrezovalnik

HR Upute za uporabu
Turbo trimer za travu

SRB Uputstvo za rad
BIH Turbo trimer-kosilica

UA Інструкція з експлуатації
Турботример

RO Instrucțiuni de utilizare
Turbotrimmer

TR Kullanma Kılavuzu
Turbo Tirpan

BG Инструкция за експлоатация
Турботример

AL Manual përdorimi
Kositëse bari turbo

EST Kasutusjuhend
Turbotrimmer

LT Eksploatavimo instrukcija
Turbo žolijaprovė

LV Lietošanas instrukcija
Turbotrimmeris

GARDENA EasyCut 400/25



Translation of the original German operating instructions.

Please read the operating instructions carefully and observe the notes given. Use these operating instructions to familiarise yourself with the product, the proper use and the safety instructions.



Never operate the product when you are tired, ill or under the influence of alcohol, drugs or medicine.

This unit may be used under supervision, or if instruction regarding the safe use of the product has been provided and the resulting dangers have been understood, by children aged 8 and above, as well as by persons with physical, sensory or mental disabilities or a lack of experience and knowledge. Children must not be allowed to play with the product. Cleaning and user maintenance must not be performed by children without supervision. The use of this product by young people under the age of 16 is not recommended.

→ Keep these operating instructions in a safe place.

Contents:

1. Area of application of your GARDENA Turbotrimmer	12
2. Safety Instructions	12
3. Assembly	14
4. Operation	15
5. Storage	17
6. Maintenance	17
7. Troubleshooting	19
8. Technical Data	20
9. Service/Warranty	20

1. Area of application of your GARDENA Turbotrimmer

Purpose:

The GARDENA Turbotrimmer is designed for trimming and cutting areas of grass and lawns in private house and hobby gardens.

The Turbotrimmer must not be used in public facilities, parks, sports grounds, next to roads or in agriculture or forestry.

Please note:



For safety reasons, the GARDENA Turbotrimmer must not be used for hedge trimming or for shredding for composting.

2. Safety Instructions

→ Please read the notes on safety on the Trimmer.



CAUTION!

→ Please read the operating instructions before using this tool.

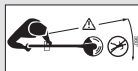

DANGER!

Risk of injury to other people!
→ Keep other people out of the area where you are working.



DANGER! Risk of electric shock!

→ Keep your Turbotrimmer away from water and rain!



**DANGER!****Eye and ear injuries!**

→ **Wear eye and hearing protection!**



→ **If the cable of the unit is damaged, the unit must be unplugged from the mains immediately.**

Check your Trimmer before each use

→ Always visually inspect your Trimmer before each use.

→ Check that the ventilation slots are not obstructed in any way.

Do not use the trimmer if it is damaged or if its safety devices (pressure switch, safety cover) and/or the filament cassette are damaged or worn.

→ Never bypass the safety devices.

→ Inspect the area to be cut before you begin work. Remove any foreign objects and look out for foreign objects (such as stones, pieces of wood, strings and wires) while you are working.

→ If you should come across an obstacle while cutting, turn off the Trimmer and unplug the mains plug. Remove the obstacle; inspect the trimmer for potential damage and arrange for it to be repaired if necessary.

→ Should the trimmer begin to vibrate abnormally, please take it out of operation and pull the mains plug. Inspect the trimmer for potential damage and arrange for it to be repaired, if necessary.

Use / responsibility**DANGER!****Tool does not stop immediately when turned off!**

→ **Keep hands and feet away from the work area until the cutting filament is stationary!**

The Trimmer can cause serious injuries.

→ Use the Trimmer only for the purpose specified in these operating instructions.

You are responsible for safety in the work area (2 metre radius).

→ Ensure that no other people (especially children) and animals are in close proximity to the danger area (15 metre radius).

In order to prevent injuries due to an accidental start-up of the device as a result of a damaged

start button, third parties must stay clear of the device upon plugging it in.

Unplug the mains plug after use and regularly inspect the trimmer, especially the filament cassette, for damage and arrange appropriate repair if necessary.

→ Always wear an eye shield or safety goggles!

→ Wear sturdy shoes and long trousers to protect your legs. Keep your fingers and feet away from the cutting filament – above all when starting work.

→ Always ensure that you have a secure foothold whilst working.

→ Keep the extension cable away from the area you are cutting.

Take extra care when walking backwards. You may stumble!

Only work in the daylight or when visibility is good.

Interrupting work

→ Never leave the Trimmer unattended where you are working.

→ If you stop work, unplug the mains plug and store your Trimmer in a safe place.

→ If you stop work in order to move to another work area, the trimmer must be switched off, wait until the work tool is stationary and then unplug the mains plug. Always carry the trimmer at the additional handle.

Familiarise yourself with the surroundings

→ Familiarise yourself with the surroundings and look out for possible dangers which you may not hear due to machine noise.

→ Never use the Trimmer when there is a risk of thunderstorms, when it is raining or in damp, wet areas.

Do not operate your Trimmer directly next to swimming pools or garden ponds.

Electrical safety

Check the power cord regularly for damage and signs of wear and tear.

Do not use your Trimmer if the power cord is damaged.

→ If the mains cord or extension cable is damaged while you are working, unplug the mains plug immediately. Do not touch the cable until the mains plug is switched off.

Supply lines must be lighter than:

- common rubber lines (H 05 RNF), if rubber-insulated;
- common PVC-coated lines (H 05 WF), if insulated with PVC.

→ Only connect the device to a mains circuit which is equipped with a residual current device (RCD) with a maximum release current of 30 mA.

In Switzerland the use of a residual-current device is obligatory.

Warning! This unit makes an electromagnetic field while it operates. This field may under some conditions interfere with active or passive medical implants. To decrease the risk of conditions that can possibly injure or kill, we recommend persons with medical implants to speak with their physician and the medical implant manufacturer before operating.

Warning! Keep toddlers away when you assemble the unit. Small parts can be easily swallowed. There is also a risk that the polybag can suffocate toddlers.

3. Assembly

Assembling the trimmer:

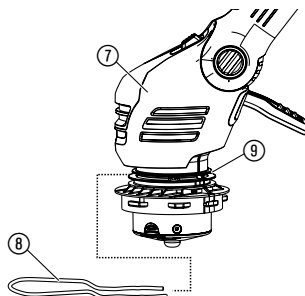
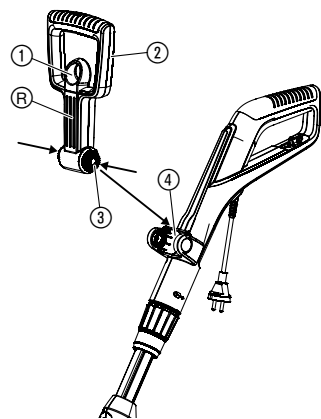

CAUTION!

The trimmer may only be operated provided that the protective cover ⑩ is assembled.

1. Pull the lock ① belonging to the additional handle ②, push in both of the snap-fits ③ belonging to the additional handle ② and, with the grooves ⑥ pointing forwards, snap them into the holder ④.
2. From the front, push the plant guard ⑧ into the upper groove ⑨ of the trimmer head ⑦. In doing so, ensure that the installed bow can rotate freely (i. e. insert the bow with the kink pointing upwards).
3. Place the protective cover ⑩ on top of the trimmer head ⑦.
4. Turn the protective cover ⑩ until it can be pushed over the trimmer head entirely (the two arrows ①①, ②② are directly across from each other).
5. Rotate the protective cover ⑩ anti-clockwise until it audibly engages.

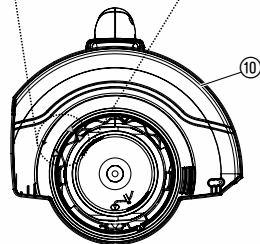
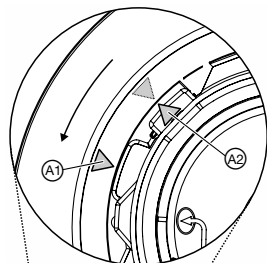

4. Operation

DANGER!



Risk of injury if the Turbotrimmer does not switch off when you release the start button.

→ **Never bypass the safety devices or switches (e.g. by tying the start button to the handle).**

Risk of injury!

→ **Unplug the mains plug of the Turbotrimmer prior to each adjustment of the working position, to the shaft length, additional handle or plant guard!**

Connecting the trimmer:

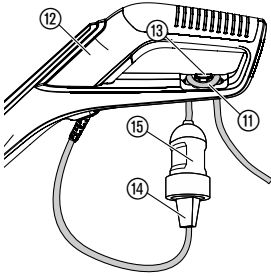

1. Insert the loop of the extension cable (11) into the cable strain relief (13) from below through the handle (12) and pull tight.
2. Plug the plug (14) of the trimmer into the socket (15) of the extension cable (11).
3. Plug the extension cable into a 230 V mains power supply.

Setting the working position:



Working position 1:
Standard trimming

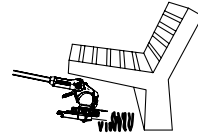

Working position 2:
Trimming beneath obstacles

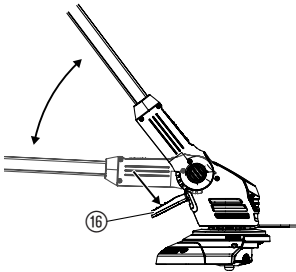

Working position 1:
For standard trimming.

Working position 2:

1. Press the foot pedal (16) and lower the shaft downwards into the desired working position.
2. Release the foot pedal (16) and allow the shaft to engage.

CAUTION! Avoid contact between the ground and the trimmer head in working position 1 + 2.

Setting the trimmer to body height:

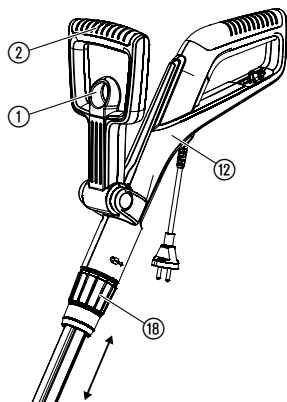

Adjusting the plant guard:

Starting the trimmer:

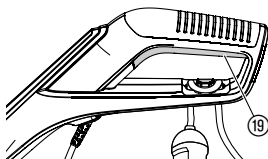

Setting the shaft length:

→ Loosen the clamping sleeve (18), extend the handle (12) to the desired shaft length and re-tighten the threaded collar (18).

The clamping sleeve (18) must be fastened firmly enough to prevent the shaft from being moved.

Setting the additional handle:

→ Pull the lock (1) belonging to the additional handle (2), set the additional handle (2) to the desired incline and release the lock (1).

If the trimmer is correctly set to the body height, the posture is upright and the trimmer head in **working position 1** is tilted forwards slightly.

→ Hold the trimmer by the handle (12) and additional handle (2) in such a manner that the trimmer head is tilted forwards slightly.

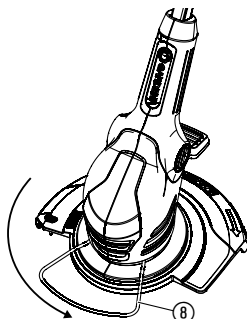

Working position

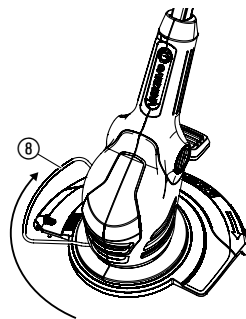

Parking position

→ Turn plant guard (8) through 90° into the required position until it locks into place.

Switching the trimmer on:

1. Press the start button (19) on the handle.

Switching the trimmer off:

→ Release the start button (19) on the handle.

Filament feed (Tip mechanism):

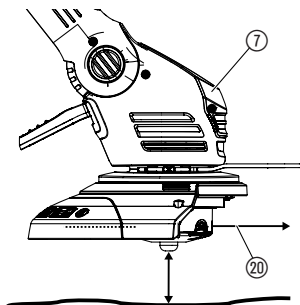

The tip mechanism works **when the motor is running**. A clean cut is only achieved with the maximum filament length. During first operation, it may be necessary to extend the cutting filament several times.

1. Start the trimmer.
2. Hold the trimmer head (7) parallel to the ground and briefly touch the trimmer head (7) onto a solid surface (avoid constant pressure over extended periods of time).

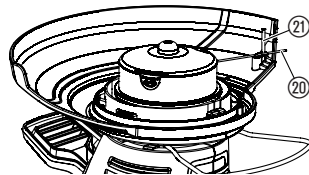

The cutting filament (20) is automatically lengthened with an audible switching process and adjusted to the correct length with the filament limiter (21). If necessary tap several times one after the other.

5. Storage

To put into storage:

Store out of the reach of children.

→ Store your Turbotrimmer in a dry place where it is protected from frost.

Recommendation:

The trimmer can be suspended by the handle.

The trimmer head is not placed upon any unnecessary strain if stored in a suspended manner.

Disposal:
(in accordance with
RL 2012/19/EU)



The product must not be added to normal household waste. It must be disposed of in line with local environmental regulations.

→ Important : Make sure that the unit is disposed of via your municipal recycling collection centre.

6. Maintenance

DANGER!



There is a risk of injury from the cutting filament!

→ **Always unplug the mains plug of the Turbotrimmer before carrying out maintenance work!**

Risk of injury and risk of damage to property!

→ **Never clean the trimmer with water or with a water jet (in particular a high-pressure water jet).**

Cleaning the trimmer:

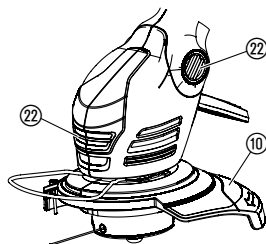

The ventilation slots must always be free of dirt.

→ Clean all moving parts after each use, and especially remove any grass and dirt from the cover (10) and ventilation slots (22).

Replacing the filament cassette:

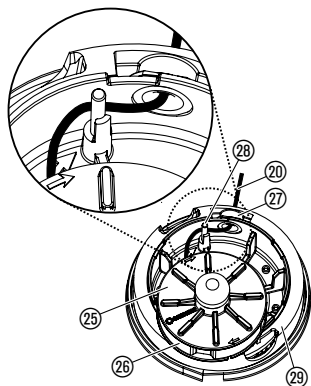
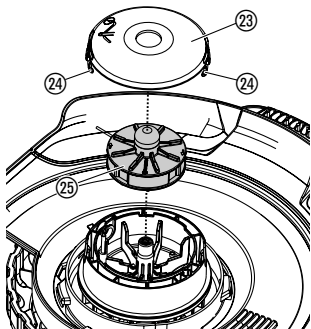

Risk of injury!

→ Never use metallic cutting elements or replacement parts and accessories not provided by GARDENA.

Only use original GARDENA Filament Cassettes. You can order Replacement Filament Cassettes from your GARDENA dealer or directly from the GARDENA Customer Service.

• for Art. 9807 EasyCut 400/25:
GARDENA Filament Cassette for Turbotrimmers Art. 5307

1. Press in cassette cover (23) on the two catches (24) at the same time and remove.
2. Remove the filament cassette (25).
3. Remove any dirt.
4. Pull approximately 15 cm of the cutting filament (20) out of the new filament cassette (25) through the hole in the plastic ring (26).
5. First thread the cutting filament (20) through the metal sleeve (27).
6. Thread the cutting filament (20) around the guide pin (28).
7. Insert the filament cassette (25) into the filament cassette holder (29).
8. Fit the cassette cover (23) on the filament cassette holder (29) so that you hear both locking clips (24) click into place.

When fitting the cassette cover (23), the cutting filament (20) must be placed around the guide pin (28) and must not be trapped.

→ If the cassette cover (23) cannot be touched down, turn the filament cassette (25) to and fro, until the filament cassette (25) is completely in the filament cassette holder (29).

DANGER!



Risk of injury from the cutting filament!

→ Always unplug the mains plug of the Turbotrimmer before troubleshooting.

Pulling the filament out of the filament cassette:

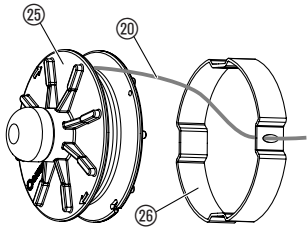
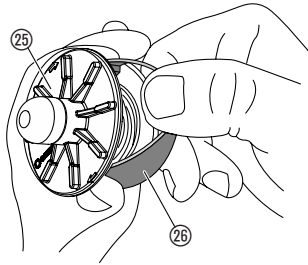

If a filament is drawn into the filament cassette you can pull it out again as described below.

1. Remove the filament cassette 25 as described under 6. Maintenance "Replacing the filament cassette".
2. Press together the plastic ring 26 on the filament cassette 25 between your thumb and forefinger.
3. Draw the plastic ring 26 over the side part of the filament cassette (use a screwdriver if necessary).
You can now access the filament that was drawn into the filament cassette.
4. Unwind the cutting filament 20 by approx. 15 cm and thread it through the eye of the plastic ring 26. If necessary, loosen the welded filament beforehand using a screwdriver, and unwind and rewind completely.
5. Pull the plastic ring 26 back over the filament cassette 25.
6. Reinstall the filament cassette 25 as described under 6. Maintenance "Replacing the filament cassette".

Problem

Possible Cause

Remedy

The trimmer no longer cuts

Filament worn or too short.

→ Lengthen the filament (see 4. Operation "Filament feed – Tip mechanism").

Filament cassette empty.

→ Replace the filament cassette (see 6. Maintenance "Replacing the filament cassette").

Filament drawn into the cassette or stuck together.

→ Pull the filament out of the filament cassette (see above).

Filament cannot be extended or filament is consumed rapidly

The filament became too dry and brittle (e. g. over the winter).

→ Place the filament in water for approx. 10 hours.

Frequent contact between the filament and hard objects.

→ Avoid contact between the filament and hard objects.



For any other malfunctions please contact the GARDENA service department. Repairs must only be carried out by GARDENA service departments or specialist dealers authorised by GARDENA.

8. Technical Data

Turbotrimmer	EasyCut 400/25 (Art. No. 9807)
Motor power consumption	400 W
Mains voltage / mains frequency	230 V / 50 – 60 Hz
Filament thickness	1.6 mm
Cutting width	250 mm
Filament supply	6 m
Filament feed	Tip mechanism
Rpm of filament cassette	approx. 12,000 rpm
Weight	approx. 2.9 kg
Telescopic adjustment of the turn handle	approx. 24 cm
Workplace-related emission values $L_{pa}^{1)}$	80 dB (A)
Uncertainty k_{pa}	3 dB (A)
Noise level $L_{WA}^{2)}$	measured 92 dB (A) / guaranteed 95 dB (A)
Uncertainty k_{WA}	3 dB (A)
Hand/arm vibration $a_{vhw}^{3)}$	3 m/s ²
Uncertainty k_a	1.5 m/s ²

Measuring process complying with ¹⁾ DIN EN 60335-2-91 ²⁾ RL2000/14/EG ³⁾ DIN EN 786. The stated vibration emission value has been measured according to a standardised test procedure and can be used for comparison of one electric power tool with another. It can also be used for preliminary evaluation of exposure. The vibration emission value can vary during actual use of the electric power tool.

9. Service/Warranty

Service:

Please contact the address on the back page.

Warranty:

In the event of a warranty claim, no charge is levied to you for the services provided.

GARDENA Manufacturing GmbH offers a two-year warranty (effective as of the date of purchase) for this product. This warranty includes all significant defects of the product that can be proved to be material or manufacturing faults. This warranty is fulfilled by supplying a fully functional replacement product or by repairing the faulty product sent to us free of charge; we reserve the right to choose between these options. This service is subject to the following provisions:

- The product was used for its intended purpose as per the recommendations in the operating instructions.

- Neither the purchaser nor a third party has attempted to repair the product.

This manufacturer's warranty does not affect warranty entitlements against the dealer/retailer.

If problems arise with this product, please contact our Service department or send the defective product along with a brief description of the fault to GARDENA Manufacturing GmbH, making sure to have sufficiently covered any shipping costs and to have followed the relevant postage and packaging guidelines. A warranty claim must be accompanied by a copy of the proof of purchase.

Consumables:

The filament cassette and cassette cover are consumables and are not covered by the guarantee.

D Produkthaftung

Wir weisen ausdrücklich darauf hin, dass wir in Übereinstimmung mit dem Produkthaftungsgesetz nicht für Schäden haften, die durch unsere Produkte entstehen, wenn diese unsachgemäß und nicht durch einen von uns autorisierten Servicepartner repariert wurden oder wenn keine Original GARDENA Teile oder von uns zugelassene Teile verwendet wurden.

GB Product liability

In accordance with the German Product Liability Act, we hereby expressly declare that we accept no liability for damage incurred from our products where said products have not been properly repaired by a GARDENA-approved service partner or where original GARDENA parts or parts authorised by GARDENA were not used.

F Responsabilité

Conformément à la loi relative à la responsabilité du fait des produits défectueux, nous déclarons expressément par la présente que nous déclinons toute responsabilité pour les dommages résultant de nos produits, si lesdits produits n'ont pas été correctement réparés par un partenaire d'entretien agréé GARDENA ou si des pièces d'origine GARDENA ou des pièces agréées GARDENA n'ont pas été utilisées.

NL Productaansprakelijkheid

Conform de Duitse wet inzake productaansprakelijkheid verklaren wij hierbij uitdrukkelijk dat wij geen aansprakelijkheid aanvaarden voor schade ontstaan uit onze producten waarbij deze producten niet zijn gerepareerd door een GARDENA-erkende servicepartner of waarbij geen originele GARDENA-onderdelen of onderdelen die door GARDENA zijn goedgekeurd zijn gebruikt.

S Produktansvar

I enlighet med tyska produktansvarslagar förklarar vi härmed uttryckligen att vi inte åtar oss något ansvar för skador som orsakas av våra produkter där produkterna inte har genomgått korrekt reparation från en GARDENA-godkänd servicepartner eller där originaldelar från GARDENA eller delar godkända av GARDENA inte använts.

DK Produktansvar

I overensstemmelse med den tyske produktansvarslov erklærer vi hermed udtrykkeligt, at vi ikke påtager os noget ansvar for skader på vores produkter, hvis de pågældende produkter ikke er blevet repareret korrekt af en GARDENA-godkendt servicepartner, eller hvor der ikke er brugt originale GARDENA-reservedele eller godkendte reservedele fra GARDENA.

FI Tuotevastuu

Saksan tuotevastuulain mukaisesti emme ole vastuussa laitteiden vaurioista, jos korjauksia ei ole tehnyt GARDENAn hyväksymä huoltoliike tai jos niiden syyinä on muiden kuin alkuperäisten GARDENA-varaosien tai GARDENAn hyväksymien varaosien käyttö.

I Responsabilità del prodotto

In conformità con la Legge tedesca sulla responsabilità del prodotto, con la presente dichiariamo espressamente che decliniamo qualsiasi responsabilità per danni causati dai nostri prodotti qualora non siano stati correttamente riparati presso un partner di assistenza approvato GARDENA o laddove non siano stati utilizzati ricambi originali o autorizzati GARDENA.

E Responsabilidad sobre el producto

De acuerdo con la Ley de responsabilidad sobre productos alemana, por la presente declaramos expresamente que no aceptamos ningún tipo de responsabilidad por los daños ocasionados por nuestros productos si dichos productos no han sido reparados por un socio de mantenimiento aprobado por GARDENA o si no se han utilizado piezas originales GARDENA o piezas autorizadas por GARDENA.

P Responsabilidade pelo produto

De acordo com a lei alemã de responsabilidade pelo produto, declaramos que não nos responsabilizamos por danos causados pelos nossos produtos, caso os tais produtos não tenham sido devidamente reparados por um parceiro de assistência GARDENA aprovado ou se não tiverem sido utilizadas peças GARDENA originais ou peças autorizadas pela GARDENA.

PL Odpowiedzialność za produkt

Zgodnie z niemiecką ustawą o odpowiedzialności za produkt, niniejszym wyraźnie oświadczamy, że nie ponosimy żadnej odpowiedzialności za szkody poniesione na skutek użytkowania naszych produktów, w przypadku gdy naprawa tych produktów nie była odpowiednio przeprowadzana przez zatwierdzonego przez firmę GARDENA partnera serwisowego lub nie stosowano oryginalnych części GARDENA albo części autoryzowanych przez tę firmę.

H Termékszavatosság

A németországi termékszavatossági törvénnyel összhangban ezennel nyomatékosan kijelentjük, hogy nem vállalunk felelősséget a termékeinkben keletkezett olyan károkért, amelyek valamely GARDENA által jóváhagyott szervizpartner által nem megfelelően végzett javításból adódtak, vagy amely során nem eredeti GARDENA alkatrészeket vagy a GARDENA által jóváhagyott alkatrészeket használtak fel.

CZ Odpovědnost za výrobek

V souladu s německým zákonem o odpovědnosti za výrobek tímto výslovně prohlašujeme, že nepřijímáme žádnou odpovědnost za poškození vzniklá na našich výrobcích, kdy zmíněné výrobky nebyly řádně opraveny schváleným servisním partnerem GARDENA nebo kdy nebyly použity originální náhradní díly GARDENA nebo náhradní díly autorizované společností GARDENA.

SK Zodpovednosť za produkt

V súlade s nemeckými právnymi predpismi upravujúcimi zodpovednosť za výrobok týmto výslovne prehlasujeme, že nenesieme žiadnu zodpovednosť za škody spôsobené našimi výrobkami, v prípade ktorých neboli náležité opravy vykonané servisným partnerom schváleným spoločnosťou GARDENA alebo neboli použité diely spoločnosti GARDENA alebo diely schválené spoločnosťou GARDENA.

GR Ευθύνη προϊόντος

Σύμφωνα με τον γερμανικό νόμο περί Ευθύνης για τα Προϊόντα, με το παρόν δηλώνουμε ρητώς ότι δεν αποδεχόμαστε καμία ευθύνη για τυχόν ζημιές που προκύπτουν από τα προϊόντα μας εάν αυτά δεν έχουν επισκευαστεί σωστά από κάποιον εγκεκριμένο συνεργάτη επισκευών της GARDENA ή εάν δεν έχουν χρησιμοποιηθεί αυθεντικά εξαρτήματα GARDENA ή εξαρτήματα εγκεκριμένα από την GARDENA.

SLO Odgovornost proizvajalca

V skladu z nemškimi zakoni o odgovornosti za izdelke, izrecno izjavljajo, da ne sprejemamo nobene odgovornosti za škodo, ki jo povzročijo naši izdelki, če teh niso ustrezno popravili GARDENINI odobreni servisni partnerji ali pri tem niso bili uporabljeni originalni GARDENINI nadomestni deli ali GARDENINIMI homologiranimi nadomestnimi deli.

HR Pouzdanost proizvoda

Sukladno njemačkom zakonu o pouzdanosti proizvoda, ovime izričito izjavljujemo kako ne prihvaćamo nikakvu odgovornost za oštećenja na našim proizvodima nastala uslijed neispravnog popravka od strane servisnog partnera kojeg odobrava GARDENA ili uslijed nekorištenja originalnih GARDENA dijelova ili dijelova koje odobrava GARDENA.

RO Răspunderea pentru produs

În conformitate cu Legea germană privind răspunderea pentru produs, declarăm în mod expres prin prezentul document că nu acceptăm nicio răspundere pentru defecțiunile suferite de produsele noastre atunci când acestea nu au fost reparate în mod corect de un atelier de service partener, aprobat de GARDENA, sau când nu au fost utilizate piese GARDENA originale sau piese autorizate de GARDENA.

BG Отговорност за вреди, причинени от стоки

Съгласно германския Закон за отговорността за вреди, причинени от стоки, с настоящото изрично декларираме, че не носим отговорност за щети, причинени от нашите продукти, ако те не са били правилно ремонтирани от одобрен от GARDENA сервиз или ако не са използвани оригинални части на GARDENA или части, одобрени от GARDENA.

EST Tootevastutus

Vastavalt Saksamaa tootevastutusseadusele deklareerime kaesolevaga selgesõnaliselt, et me ei kannu mingisugust vastutust meie toodetest tingitud kahjude eest, kui need tooted ei ole korrektselt parandatud GARDENA heakskiidetud hoolduspartneri poolt või kui parandamisel ei ole kasutatud GARDENA originaalosi või GARDENA volitatud osi.

LT Gaminio patikimumas

Mes aiškiai pareiškiame, kad, atsižvelgiant į Vokietijos gaminių patikimumo įstatymą, nepriisiame atsakomybės dėl bet kokios žalos, patirtos dėl mūsų gaminių, jeigu jie buvo netinkamai taisomi arba jų dalys buvo pakeistos neoriginaliomis GARDENA dalimis ar nepatvirtintomis dalimis, arba jeigu remonto darbai buvo atliekami ne GARDENA techninės priežiūros centro specialistų.

LV Atbildība par produkcijas kvalitāti

Saskaņā ar Vācijas likumu par atbildību par produkcijas kvalitāti ar šo mēs paziņojam, ka neuzņemamies atbildību par bojājumiem, kas radušies, lietojot mūsu izstrādājumus, kuru remontu nav veicis uzņēmuma GARDENA apstiprināts apkopes partneris vai kuru remontam netika izmantotas oriģinālās GARDENA detaļas vai detaļas, kuru lietošanu apstiprinājis uzņēmums GARDENA.

<p>D EU-Konformitätserklärung Der Unterzeichner, Husqvarna AB, 561 82 Huskvarna, Schweden, bescheinigt hiermit, dass die nachstehend aufgeführten Geräte bei Verlassen des Werks die harmonisierten EU-Leitlinien, EU-Normen für Sicherheit und besondere Normen erfüllen. Dieses Zertifikat verliert seine Gültigkeit, wenn die Geräte ohne unsere Genehmigung verändert werden.</p>	<p>H EK megfeleléiségi nyilatkozat Alulírott Husqvarna AB, 561 82 Huskvarna, Svédország ezzel tanúsítja, hogy az alábbiakban leírt egységek a gyár elhagyásakor megfeleltek a harmonizált uniós előírásoknak és biztonsági és termékspecifikus szabványoknak. Ez a tanúsítvány érvényes veszt, ha az egységeket jóváhagyásunk nélkül átalakítják.</p>
<p>GB EC Declaration of Conformity The undersigned, Husqvarna AB, 561 82 Huskvarna, Sweden, hereby certifies that, when leaving our factory, the units indicated below are in accordance with the harmonised EU guidelines, EU standards of safety and product specific standards. This certificate becomes void if the units are modified without our approval.</p>	<p>CZ Prohlášení o shodě ES Níže uvedená společnost Husqvarna AB, 561 82 Huskvarna, Švédsko, tímto potvrzuje, že při opuštění naší továrny jsou jednotky uvedené níže v souladu s harmonizovanými pokyny EU, standardy EU ohledně bezpečnosti a specifickými produktovými standardy. Tento certifikát pozbyvá platnosti, pokud dojde k úpravě jednotek bez našeho schválení.</p>
<p>F Déclaration de conformité CE Le constructeur, soussigné : Husqvarna AB, 561 82 Huskvarna, Suède, déclare que à la sortie de ses usines le matériel neuf désigné ci-dessous était conforme aux prescriptions des directives européennes énoncées ciaprès et conforme aux règles de sécurité et autres règles qui lui sont applicables dans le cadre de l'Union européenne. Toute modification apportée à cet appareil sans notre accord annule la validité de ce certificat.</p>	<p>SK EÚ vyhlásenie o zhode Dolu podpísaná spoločnosť Husqvarna AB, 561 82 Huskvarna, Švédsko týmto osvedčuje, že nižšie uvedené jednotky boli v súlade s harmonizovanými usmerneniami EÚ, normami EÚ v oblasti bezpečnosti a špecifickými normami týkajúcimi sa produktu v čase opustenia výrobného závodu. Toto osvedčenie stráca platnosť, ak boli jednotky zmenené bez nášho súhlasu.</p>
<p>NL EG-conformiteitsverklaring De ondergetekende, Husqvarna AB, 561 82 Huskvarna, Zweden, verklaart hierbij dat de producten die hieronder staan vermeld, wanneer ze onze fabriek verlaten, in overeenstemming zijn met de geharmoniseerde Europese richtlijnen, EU-normen voor veiligheid en productspecifieke normen. Dit certificaat vervalt als de producten worden aangepast zonder onze toestemming.</p>	<p>GR Δήλωση Συμμόρφωσης ΕΚ Η υπογεγραμμένη εταιρεία, Husqvarna AB, 561 82 Huskvarna, Σουηδία, πιστοποιεί ότι, κατά την έξοδο από το εργοστάσιο, οι μονάδες που αναφέρονται κατωτέρω συμμορφώνονται με τις ευρωπαϊκές οδηγίες ΕΕ, τα πρότυπα ασφαλείας της ΕΕ και τα συγκεκριμένα πρότυπα προϊόντος. Αυτό το πιστοποιητικό καθίσταται άκυρο εάν οι μονάδες έχουν τροποποιηθεί χωρίς την έγκρισή μας.</p>
<p>S EG-försäkran om överensstämmelse Undertecknad firma Husqvarna AB, 561 82 Huskvarna, Sverige, intygar härmed att nedan nämnda produkter, när de lämnar vår fabrik, överensstämmer med EU:s riktlinjer, EU:s säkerhetsstandarder och produktspecifika standarder. Detta intyg skall offentliggöras om produkten ändras utan vårt godkännande.</p>	<p>SLO Izjava ES o skladnosti Spodaj podpisana, Husqvarna AB, 561 82 Huskvarna, Švedska, s to izjavo potrjuje, da je bila spodaj navedena enota ob izhodu iz tovarne skladna z usklajalnimi smernicami EU, standardi EU za varnost in standardi, specifičnimi za izdelek. Izjava postane neveljavna v primeru neodobrene spremembe enote.</p>
<p>DK EU-overensstemmelseserklæring Undertegnede, Husqvarna AB, 561 82 Huskvarna, Sverige erklærer hermed, at nedenfor anførte enheder er i overensstemmelse med de harmoniserede EU-retningslinjer, EU-standarder for sikkerhed og produktspecifikke standarder, når de forlader fabrikken. Denne erklæring ugyldiggøres, hvis enhederne ændres uden vores godkendelse.</p>	<p>HR Izjava o uskladenosti EZ Níže potpisana Husqvarna AB, 561 82 Huskvarna, Švedska, ovime potvrđuje kako su u nastavku navedene jedinice prilikom napuštanja tvornice bile u skladu s uskladenim smjernicama EU, EU sigurnosnim standardima i standardima specifičnima za proizvod. Ova certifikacija poništava se ako se jedinice izmjenjuju bez odobrenja.</p>
<p>FI EY-vaatimustenmukaisuusvakuutus Husqvarna AB, 561 82 Huskvarna, Ruotsi, vakuuttaa täten, että alla mainitut laitteen ovat tehtaalta lähtiesään yhdenmukaiset EU-säännösten, EU:n turva-standardien ja tuotekohtaisten standardien mukaisia. Tämä vakuutus mitätöityy, jos laitteita muokataan ilman hyväksyntäämme.</p>	<p>RO Declarație de conformitate CE Subscrisa, Husqvarna AB, 561 82 Huskvarna, Suedia, certifică prin prezenta că, la momentul ieșirii din fabrica noastră, unitățile indicate mai jos sunt în conformitate cu directivele UE armonizate, cu standardele UE de siguranță și cu standardele specifice ale produsului. Prezentul certificat devine nul dacă unitățile sunt modificate fără aprobarea noastră.</p>
<p>I Dichiarazione di conformità CE La sottoscritta Husqvarna AB, 561 82 Huskvarna, Svezia, certifica che il prodotto qui di seguito indicato, nei modelli da noi commercializzati, è conforme alle direttive armonizzate UE nonché agli standard di sicurezza UE e agli standard specifici di prodotto. Qualunque modifica apportata al prodotto senza nostra specifica autorizzazione invalida la presente dichiarazione.</p>	<p>BG Декларация за съответствие на ЕО С настоящото долуподписаната, Husqvarna AB, 561 82 Huskvarna, Швеция, удостоверява, че при напускане на фабриката модулите, посочени по-долу, са в съответствие с хармонизираните директиви на ЕС, стандартите на ЕС за безопасност и специфичните за продукта стандарти. Този сертификат става невалиден, ако модулите са променени без нашето одобрение.</p>
<p>E Declaración de conformidad CE El abajo firmante, Husqvarna AB, 561 82 Huskvarna, Suecia, certifica por la presente que, cuando salen de la fábrica, las unidades indicadas a continuación cumplen las normas de armonización de la UE, las normas de la UE sobre seguridad y las normas específicas del producto. Este certificado quedará sin efecto si se modifican las unidades sin nuestra autorización.</p>	<p>EST EÜ vastavusdeklaratsioon Allkirjutatu Husqvarna AB, 561 82 Huskvarna, Rootsi, kinnitab käesolevaga, et tehased väljumeis vastavad alpool nimetatud seadmed harmoneeritud EL-i suunistele, EL-i ohutusstandarditele ja tootele eriomastele standarditele. See vastavuskinnitus kaotab kehtivuse, kui seadet muudetakse ilma meie heakskiuduta.</p>
<p>P Declaração de conformidade CE O abaixo-assinado, Husqvarna AB, 561 82 Huskvarna, Suécia, certifica por este meio que, ao sair da nossa fábrica, as unidades indicadas acima estão em conformidade com as diretrizes uniformizadas da UE, os padrões de segurança da UE e os padrões específicos do produto. Este certificado deixa de ser válido se as unidades forem modificadas sem a nossa aprovação.</p>	<p>LT EB atitikties deklaracija Husqvarna AB, 561 82 Huskvarna, Sweden, garantuoja, kad iš gamyklos siunčiami toliau nurodyti įrenginiai atitinka suderintus EB reikalavimus, EB saugos ir konkretaus gamtinio standartus. Pakeltus gaminius be mūsų patvirtinimo, nautraikiamas šio sertifikato galiojimas.</p>
<p>PL Deklaracja zgodności WE Nízej podpisaný predstaviteľ firmy Husqvarna AB, 561 82 Huskvarna, Szwecja, niniejszym oświadcza, że podane poniżej wyroby opuszczające fabrykę są zgodne ze zharmonizowanymi normami UE oraz z obowiązującymi w UE przepisami bezpieczeństwa i normami dotyczącymi danego produktu. Modyfikacja wyrobów bez naszej zgody powoduje unieważnienie niniejszego certyfikatu.</p>	<p>LV EK atbilstības deklarācija Uzņēmums Husqvarna AB, 561 82 Huskvarna, Zviedrija, ar parakstu apliecina, ka tālāk minētās vienības, pametot rūpniec, atbilst saskatotajām ES vadlīnijām, ES drošības standartiem un izstrādājumiem specifiskajiem standartiem. Šis sertifikāts tiek anulēts, ja šīs vienības tiek modificētas bez mūsu apstiprinājuma.</p>

Deutschland / Germany

GARDENA
Manufacturing GmbH
Central Service
Hans-Lorenser-Straße 40
D-89079 Ulm
Produktfragen:
(+49) 731 490-123
Reparaturen:
(+49) 731 490-290
service@gardena.com

Albania

COBALT Sh.p.k.
Rr. Siri Kodra
1000 Tirana

Argentina

Husqvarna Argentina S.A.
Av.del Libertador 5954 –
Piso 11 – Torre B
(C1428ARP) Buenos Aires
Phone: (+54) 11 5194 5000
info.gardena@
ar.husqvarna.com

Armenia

Garden Land Ltd.
61 Tigran Mets
0005 Yerevan

Australia

Husqvarna Australia Pty. Ltd.
Locked Bag 5
Central Coast BC
NSW 2252
Phone: (+61) (0) 2 4352 7400
customer.service@
husqvarna.com.au

Austria / Österreich

Husqvarna Austria GmbH
Industriezeile 36
4010 Linz
Tel.: (+43) 732 77 01 01-485
service.gardena@
husqvarnagroup.com

Azerbaijan

Firm Progress
a. Aliyev Str. 26A
1052 Baku

Belgium

Husqvarna België nv/sa
Gardena Division
Rue Egide Van Ophem 111
1180 Uccle / Ukkel
Tel.: (+32) 2 720 92 12
info@gardena.be

Bosnia / Herzegovina

SILK TRADE d.o.o.
Industrijska zona Bukva bb
74260 Tešanj

Brazil

Husqvarna do Brasil Ltda
Av. Francisco Matarazzo,
1400 – 19º andar
São Paulo – SP
CEP: 05001-903
Tel: 0800-112252
marketing.br.husqvarna@
husqvarna.com.br

Bulgaria

AGROLAND България АД
бул. 9 Декември, №13
Офис 5
1700 Студентски град
София
Тел.: (+359) 24666910
info@agroland.eu

Canada / USA

GARDENA Canada Ltd.
100 Summerlea Road
Brampton, Ontario L6T 4X3
Phone: (+1) 905 792 9330
info@gardenacanada.com

Chile

Maquinarias Agroforestales
Ltda. (Maga Ltda.)
Santiago, Chile
Avda. Chesterton
8355 comuna Las Condes
Phone: (+56) 2 202 4417
Dalton@maga.cl
Zipcode: 7560330

China

Husqvarna (China) Machinery
Manufacturing Co., Ltd.
No. 1355, Jia Xin Rd.,
Ma Lu Zhen, Jia Ding Dist.,
Shanghai
201801
Phone: (+86) 21 59159629
Domestic Sales
www.gardena.com.cn

Colombia

Husqvarna Colombia S.A.
Calle 18 No. 68 D-31, zona
Industrial de Montevideo
Bogotá, Cundinamarca
Tel. 571 2922700 ext. 105
jairo.salazar@
husqvarna.com.co

Costa Rica

Compania Exim
Euroiberoamericana S.A.
Los Colegios, Moravia,
200 metros al Sur del Colegio
Saint Francis – San José
Phone: (+506) 297 68 83
exim_euro@racsa.co.cr

Croatia

SILK ADRIA d.o.o.
Josipa Lončara 3
10090 Zagreb
Phone: (+385) 1 3794 580
silk.adria@zg.t-com.hr

Cyprus

Med Marketing
17 Digeni Akrita Ave
P.O. Box 27017
1641 Nicosia

Czech Republic

Husqvarna Česko s.r.o.
Türkova 2319/5b
149 00 Praha 4 – Chodov
Bezplatná infolinka:
800 100 425
servis@cz.husqvarna.com

Denmark

GARDENA DANMARK
Lejrvvej 19, st.
3500 Værløse
Tlf.: (+45) 70264770
husqvarna@husqvarna.dk
www.gardena.com/dk

Dominican Republic

BOSQUESA, S.R.L
Carretera Santiago Licey
Km. 5 ½
Esquina Copal II,
Santiago
Dominican Republic
phone: (+809) 736-0333
joserbosquesa@claro.net.do

Ecuador

Husqvarna Ecuador S.A.
Arupos E1-181 y 10 de
Agosto Quito, Pichincha
Tel. (+593) 22800739
francisco.jacome@
husqvarna.com.ec

Estonia

Husqvarna Eesti OÜ
Gardena Division
Valdeku 132
Tallinn
11216, Estonia
info@gardena.ee

Finland

Oy Husqvarna Ab
Gardena Division
Lauttarhankatu 8 / PL 3
00581 HELSINKI
info@gardena.fi

France

Husqvarna France
9/11 Allée des pierres mayettes
92635 Gennevilliers Cedex
France
http://www.gardena.com/fr
N° AZUR: 0 810 00 78 23
(Prix d'un appel local)

Georgia

ALD Group
Beliasvili 8
1159 Tbilisi

Great Britain

Husqvarna UK Ltd
Preston Road
Aycliffe Industrial Park
Newton Aycliffe
County Durham
DL5 6UP
info.gardena@
husqvarna.co.uk

Greece

Π. ΠΑΠΑΔΟΠΟΥΛΟΣ ΑΕΒΕ
Λεωφ. Αθηνών 92
Αθήνα
T.K. 104 02
Ελλάδα
Τηλ. (+30) 210 5193100
info@papadopoulos.gr

Hungary

Husqvarna Magyarorszá g Kft.
Ezred u. 1-3
1044 Budapest
Telefon: (+36) 1 251-4161
vevoszolgalat.husqvarna@
husqvarna.hu

Iceland

O. Johnson & Kaaber
Túngahalsi 1
110 Reykjavik
ojo@ojk.is

Ireland

Husqvarna UK Ltd
Preston Road
Aycliffe Industrial Park
Newton Aycliffe
County Durham
DL5 6UP
info.gardena@
husqvarna.co.uk

Italy

Husqvarna Italia S.p.A.
Via Santa Vecchia 15
23868 VALMADRERA (LC)
Phone: (+39) 0341.203.111
assistenza.italia@
it.husqvarna.com

Japan

KAKIUCHI Co. Ltd.
Sumitomo Realty &
Development Kojimachi
BLDG., 8F
5-1 Nibanncyo
Chiyoda-ku
Tokyo 102-0084
Phone: (+81) 33 264 4721
m_ishihara@kaku-ichi.co.jp

Kazakhstan

LAMED Ltd.
155/1, Tazhibayevoy Str.
050060 Almaty
IP Schmidt
Abayavenue 3B
110 005 Kostanay

Korea

Kyung Jin Trading CO.,LTD.
107-4, SunDuk Bid.,
YangJae-dong,
Seocho-gu,
Seoul, (zipcode: 137-891)
Phone: (+82) (0)2 574-6300

Kyrgyzstan

Alye Maki
av. Molodaya Guardir J 3
720014
Bishkek

Latvia

Husqvarna Latvija SIA
Gardena Division
Ulbrokas 19A
LV-1021 Riga
info@gardena.lv

Lithuania

LIUB Husqvarna Lietuva
Gardena Division
Ateities pl. 77C
LT-52104 Kaunas
info@gardena.lt

Luxembourg

Magasins Jules Neuberg
39, rue Jacques Stas
Luxembourg-Gasperich 2549
Case Postale No. 12
Luxembourg 2010
Phone: (+352) 40 14 01
api@neuberg.lu

Mexico

AFOSA
Av. Lopez Mateos Sur # 5019
Col. La Calma 45070
Zapopan, Jalisco
Mexico
Phone: (+52) 33 3818-3434
icornejo@afosa.com.mx

Moldova

Convel S.R.L.
290A Muncest Str.
2002 Chisinau

Netherlands

Husqvarna Nederland B.V.
GARDENA Division
Postbus 50131
1305 AC ALMERE
Phone: (+31) 36 521 00 10
info@gardena.nl

Neth. Antilles

Jonka Enterprises N.V.
Sta. Rosa Weg 196
P.O. Box 8200
Curaçao
Phone: (+599) 9 767 66 55
pgm@jonka.com

New Zealand

Husqvarna New Zealand Ltd.
PO Box 76-437
Manukau City 2241
Phone: (+64) (0) 9 9202410
support.nz@husqvarna.co.nz

Norway

Husqvarna Norge AS
Gardena Division
Trøskeneveien 36
1708 Sarpsborg
Tel: 69 10 47 00
www.gardena.no

Peru

Husqvarna Perú S.A.
Rr. Ramón Cárcamo 710
Lima 1
Tel: (+51) 1 3320400 ext. 416
juan.remuzgo@
husqvarna.com

Poland

Husqvarna Spółka z o.o.
ul. Wysockiego 15 b
03-371 Warszawa
Phone: (+48) 22 330 96 00
gardena@husqvarna.com.pl

Portugal

Husqvarna Portugal, SA
Lagoa – Albarraque
2635 – 505 Rio de Mouro
Tel.: (+351) 21 922 85 30
Fax : (+351) 21 922 85 36
info@gardena.pt

Romania

Madex International Srl
Soseaua Odaii 117 - 123,
RO 013603 Bucuresti, S 1
Phone: (+40) 21 352.76.03
madex@ines.ro

Russia / Россия

ООО „Хускварна“
141400, Московская обл.,
г. Химки,
улица Ленинградская,
выделение 39, стр.6
Бизнес Центр
„Химки Бизнес Парк“,
помещение 0B02.04
http://www.gardena.ru

Serbia

Domel d.o.o.
Autoput za Novi Sad bb
11273 Belgrade
Phone: (+381) 11 84 88 82
mroslav.jejina@domel.rs

Singapore

Hay-RR PRIVATE LIMITED
40 Jaiann Permipin
02-08 Tat Ann Building
Singapore 577185
Phone: (+65) 6253 2277
shiyang@hhyray.com.sg

Slovak Republic

Husqvarna Česko s.r.o.
Türkova 2319/5b
149 00 Praha 4 – Chodov
Bezplatná infolinka:
800 154 044
servis@sk.husqvarna.com

Slovenia

Husqvarna Austria GmbH
Industriezeile 36
4010 Linz
Tel.: (+43) 732 77 01 01-485
service.gardena@
husqvarnagroup.com

South Africa

Husqvarna
South Africa (Pty) Ltd
Postnet Suite 250
Private Bag X6,
Cascades, 3202
South Africa
Phone: (+27) 33 846 9700
info@gardena.co.za

Spain

Husqvarna España S.A.
Calle de Rivas nº 10
28052 Madrid
Phone: (+34) 91 708 05 00
atencioncliente@gardena.es

Suriname

Agrofix n.v.
Verlengde Hogestraat # 22
Phone: (+597) 472426
agrofix@sr.net
Pobox : 2006
Paramaribo

Sweden

Husqvarna AB
Gardena Division
S-561 82 Huskvarna
info@gardena.se

Switzerland / Schweiz

Husqvarna Schweiz AG
Consumer Products
Industriestrasse 10
5506 Mägenwil
Phone: (+41) (0) 62 887 37 90
info@gardena.ch

Turkey

GARDENA Dost Diş Ticaret
Müesseslik A.Ş.
Sanayi Cad. Adil Sokak
No: 1/B Kartal
34873 Istanbul
Phone: (+90) 216 38 93 939
info@gardena-dost.com.tr

Ukraine / Україна

ТОВ „Хусварна Україна“
вул. Васильківська, 34,
офіс 204-р
03022, Київ
Тел. (+38) 044 498 39 02
info@gardena.ua

Uruguay

FELISA
Entre Rios 1083 CP 11800
Montevideo – Uruguay
Tel: (+598) 22 03 18 44
info@felisa.com.uy

Venezuela

Corporación Casa y Jardín C.A.
Av. Caroní, Edif. Trezmen, P.B.
Colinas de Bello Monte,
1050 Caracas.
Tlf: (+58) 212 992 33 22
info@casayjardin.net.ve

9807-20.960.03/0317
© GARDENA
Manufacturing GmbH
D-89070 Ulm
http://www.gardena.com