ES 500 Art. 4066

D Betriebsanleitung Elektro-Rasenlüfter	SK Návod na obsluhu Elektrický prevzdušňovač
GB Operator's manual Electric Lawn Rake	GR Οδηγίες χρήσης Ηλεκτρικός εξαερωτής γραζόν
F Mode d'emploi Aérateur électrique	RUS Инструкция по эксплуатации Аэратор газонный электрический
NL Gebruiksaanwijzing Elektrische gazonbeluchter	SLO Navodilo za uporabo Električni prezračevalnik trate
S Bruksanvisning Elektrisk Gräsmatteluftare	HR Upute za uporabu Električni prozračivač
DK Brugsanvisning Elektrisk Plænelufter	SRB Uputstvo za rad BIH Električni aerator za travnjake
FI Käyttöohje Sähkökäyttöinen ilmastointilaite	UA Інструкція з експлуатації Аератор газонний електричний
N Bruksanvisning Elektrisk plenlufter	RO Instrucțiuni de utilizare Aerator electric
I Istruzioni per l'uso Arieggiatore elettrico	TR Kullanma Kılavuzu Elektro-Çim Havalandırıcı
E Instrucciones de empleo Aireador de césped eléctrico	BG Инструкция за експлоатация Електрическо гребло за трева
P Manual de instruções Arejador de relva eléctrico	AL Manual përdorimi Elektro-Ajrosës për Lëndina
PL Instrukcja obsługi Elektryczny aerator	EST Kasutusjuhend Elektriline murureha
H Használati utasítás Elektromos gyepszellőztető	LT Eksploatavimo instrukcija Elektrinis samanų grėblys
CZ Návod k obsluze Elektrický provzdušňovač	LV Lietošanas instrukcija Elektriskais zālāju grābeklis

GARDENA Electric Lawn Rake ES 500



Translation of the original German operating instructions.

Please read these operating instructions carefully and observe the notes given. Use these operating instructions to familiarise yourself with the Electric Lawn Rake, its proper use and the notes on safety.



This product may be used under supervision, or if instruction regarding the safe use of the product has been provided and the resulting dangers have been understood, by children aged 8 and above, as well as by persons with physical, sensory or mental disabilities or a lack of experience and knowledge. Children must not be allowed to play with the product. Cleaning and user maintenance must not be performed by children without supervision. The use of this product by young people under the age of 16 is not recommended.

→ Please keep these operating instructions in a safe place.

Contents:

1. Where to Use Your GARDENA Electric Lawn Rake	12
2. Safety Instructions	12
3. Function	14
4. Assembly	15
5. Operation	16
6. Maintenance	16
7. Trouble-Shooting	17
8. Storage	19
9. Accessories	19
10. Technical Data	20
11. Service/Warranty	20

1. Where to Use Your GARDENA Electric Lawn Rake

Intended use:

The GARDENA Electric Lawn Rake ES 500 is designed for aerating lawns and grassy areas in private domestic and hobby gardens. It is not designed for use in public facilities, parks, sporting grounds, on roads, in agriculture or forestry.

Compliance with these instructions provided by GARDENA is a prerequisite for using the Electric Lawn Rake correctly.

Please note:



Attention! To prevent injury, the Electric Lawn Rake must not be used for trimming bushes, hedges and shrubs. In addition, the Electric Lawn Rake must not be used for levelling irregularities in the soil.

2. Safety Instructions

→ Please observe the notes on safety on the Electric Lawn Rake.



WARNING!

Read operator's manual.



DANGER!

Keep bystanders away.

**DANGER! Electric shock!**

Keep supply flexible cord away from tines.

**WARNING!**

Beware of sharp tines!
Keep fingers and toes away.

Remove plug from mains before maintenance, adjusting, cleaning or if the cord is entangled or damaged. Tines continue to rotate after the motor is switched off.

1. General

This annex presents safe operating practices for all machine types covered by this standard.

IMPORTANT!

**READ CAREFULLY BEFORE USE.
KEEP FOR FUTURE REFERENCE.**

2. Safe operating practices for scarifiers / aerators**2.1 Training**

- a) Read the instructions carefully. Be familiar with the controls and the correct use of the equipment.
- b) Never allow **children** or people unfamiliar with these instructions to use the machine. Local regulations can restrict the age of the operator.
- c) Keep in mind that the operator or user is responsible for accidents or hazards occurring to other people or their property.

2.2 Preparation

- a) Wear ear protection and safety glasses at all times while operating the machine.
- b) Before use check the supply and extension cord for signs of damage or aging. If the cord becomes damaged during use, disconnect the cord from the supply immediately.
DO NOT TOUCH THE CORD BEFORE DISCONNECTING THE SUPPLY.
Do not use the machine if the cord is damaged or worn.
- c) While operating the machine always wear substantial footwear and long trousers. Do not operate the machine when barefoot or wearing open sandals. Avoid wearing clothing that is loose fitting or that has hanging cords or ties.
- d) Thoroughly inspect the area where the equipment is to be used and remove all objects which can be thrown by the machine.
- e) Operate the machine in a recommended position and only on a firm, level surface.
- f) Do not operate the machine on a paved or gravel surface where ejected material could cause injury.
- g) Before starting the machine, check that all screws, nuts, bolts, and other fasteners are properly secured and that guards and screens in place. Replace damaged or unreadable labels.
- h) Never operate the machine while people, especially children, or pets are nearby.

2.3 Operation

- a) Operate the machine only in daylight or in good artificial light.
- b) Avoid operating the machine in wet grass.
- c) Always be sure of your footing at all times, especially on slopes.

- d) Walk, never run.
- e) Mow across the face of slopes, never up and down.
- f) Exercise extreme caution when changing direction on slopes.
- g) Do not scarify or aerate excessively steep slopes.
- h) Use extreme caution when reversing or pulling the machine towards you.
- i) Stop the **tines** if the machine has to be tilted for transportation when crossing surfaces other than grass, and when transporting the machine to and from the area to be used.
- j) Never operate the machine with defective **guards** or shields, or without safety devices, for example deflectors and/or grass collector, in place.
- k) Switch on the motor carefully according to instructions and with feet well away from the **tines**.
- l) Keep supply and extension cord away from **tines**.
- m) Do not tilt machine when switching on the motor, except if the machine has to be tilted for starting. In this case, do not tilt it more than absolutely necessary and lift only the part which is away from the operator. Always ensure that both hands are in the operating position before returning the machine to the ground.
- n) Do not transport the machine while the power source is running.
- o) Do not put hands or feet near or under rotating parts. Keep clear of the **discharge opening** at all times.
- p) Stop the machine, and remove plug from the socket. Make sure that all moving parts have come to a complete stop:
 - 1) whenever you leave the machine,
 - 2) before clearing blockages or unclogging chute,
 - 3) before checking, cleaning or working on the machine,
 - 4) after striking a foreign object. Inspect the machine for damage and make repairs before restarting and operating the machine;
 if the machine starts to vibrate abnormally (check immediately):
 - 5) inspect for damage,
 - 6) replace or repair any damaged parts,
 - 7) check for and tighten any loose parts.

2.4 Maintenance and storage

- a) Keep all nuts, bolts and screws tight to be sure the equipment is in safe working condition.
- b) Check the debris collector frequently for wear or deterioration.
- c) Replace worn or damaged parts for safety.

- d) On machines with multiple **tine** assemblies, take care as rotating one **tine** assembly can cause another **tine** assembly to rotate.
- e) Be careful during adjustment of the machine to prevent entrapment of the fingers between moving **tine** assemblies and fixed parts of the machine.
- f) Always allow the machine to cool down before storing.
- g) When servicing the **tine** assembly be aware that, even though the power source is switched off, the **tine** assembly can still be moved.
- h) Replace worn or damaged parts for safety. Use only genuine replacement parts and accessories.
- i) When the machine is stopped for servicing, inspection, or storage, or to change an accessory, shut off the power source, disconnect the machine from the supply and make sure that all moving parts are come to a complete stop. Allow the machine to cool before making any inspections, adjustments, etc. Maintain the machine with care and keep it clean.
- j) Store the machine out of the reach of children.

2.5 Recommendation

The machine should be supplied via a residual current device (RCD) with a tripping current of not more than 30 mA.

Electrical safety



WARNING! Electric shock!
Risk of injury due to electric shock.

Disconnect the product from the mains before you do maintenance or you replace parts. Thereby the disconnected socket must be in the visual range.

Cables

If extension cables are used, these must comply with the minimum cross-sections in the table below:

Voltage	Cable length	Cross section
220 – 240 V / 50 Hz	up to 20 m	1.5 mm ²
220 – 240 V / 50 Hz	20 – 50 m	2.5 mm ²

1. Mains cables and extensions are available from your local Approved Service Centre.
2. Only use extension cables specifically designed for outdoor use and which conform to one of the following specifications: Ordinary rubber (60245 IEC 53), Ordinary PVC (60227 IEC 53) or Ordinary PCP (60245 IEC 57).
3. If the short connection lead is damaged, it must be replaced by the manufacturer, its service agent or similarly qualified persons in order to avoid a hazard.

Attachment fittings must be used for extension cables. In Switzerland use of a residual-current device is obligatory.

Checks before each use

→ Inspect the Electric Lawn Rake before each use. For safety reasons, allow all worn out and damaged parts to be exchanged by GARDENA Service or authorised specialist dealers.

Proper use / Responsibility



DANGER! Risk of injury!
The Electric Lawn Rake can cause serious injuries!

- Keep hands and feet away from the aerator cylinder.
- During use do not tip the unit and do not open the rear flap.
- Familiarise yourself with the surroundings of your working area. Check for possible risks which might be not audible due to the noise of the machine.
- Always push the Electric Lawn Rake at a walking pace.
- **Attention! Take extra care when walking backwards. You may stumble!**
- Do not use the Electric Lawn Rake if it is raining or in moist, wet conditions.
- Do not use the product when a thunderstorm is approaching.
- Do not work close to the edge of swimming pools or garden ponds with the Electric Lawn Rake.
- Please observe any local restrictions relating to noise levels.

Do not overload the product.

This product is not intended for long term use. Don't work until exhaustion.

Do not operate the product in explosive atmospheres, such as in the presence of flammable liquids, gases or dust. The product can create sparks which may ignite the dust or fumes.

Never operate the product when you are tired, ill or under the influence of alcohol, drugs or medicine.

WARNING! Cardiac arrest!

This product makes an electromagnetic field while it operates. This field may under some conditions interfere with active or passive medical implants. To decrease the risk of conditions that can possibly injure or kill, we recommend persons with medical implants to speak with their physician and the medical implant manufacturer before you operate the product.

Risk of suffocation!

Small could be swallowed during assembly and there is a risk of suffocation from the poly bag. Scrap the plastic bags immediately after assembling the product.

3. Function

Correct aerating:

The Electric Lawn Rake can be used for removing matting and moss in the lawn as well as for cutting flat-rooting ranks.

To maintain a well-cared-for lawn we recommend aerating every 4 – 6 weeks depending on the state of your lawn.

- First of all, mow your lawn to the length you require.
We particularly recommend this if the grass has grown tall (e.g. while you were away on holiday).

Recommendation: the shorter you mow your lawn, the easier it is to aerate, thus lessening the strain on the Electric Lawn Rake and increasing the lifetime of the aerator cylinder.

Remaining in one spot too long, or aerating if the ground is wet or too dry can damage the grass.

- For good results, guide the Electric Lawn Rake at an appropriate speed in strips as straight as possible across your lawn.

To avoid leaving any gaps during aerating, the strips should touch.

- Always guide the Electric Lawn Rake at an even speed depending on the type of ground.

- When working on inclines always stand diagonally to the incline in a sturdy, safe stance. Do not work on extremely steep slopes.

Danger of tripping!

To prevent tripping take particular care when moving backwards and when pulling the Electric Lawn Rake.

When aerating areas of very mossy lawn we recommend resowing the lawn after aerating. This helps the areas of lawn which were replaced by moss to regenerate more quickly.

4. Assembly

Assembling the handle:



→ **Do not place the connecting cable ⑧ under strain during assembly.**

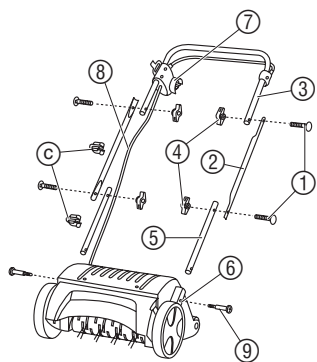

1. Insert the two lower sections of the upright ⑤ (with the end with the round hole) in the mountings in the motor casing ⑥ and secure with the crosshead screws ⑨.
2. Insert the two locking bolts ① from outside through the holes in the two central sections ② of the upright and secure to the lower sections of the upright ⑤ with two wing nuts ④.
3. Screw the upper part of the upright with starting handle ③ to the central sections of the upright ② with two more locking bolts ① and the wing nuts ④.
This completes the assembly of the handle.

Warning: Fit the upper section of the upright with starting handle ③ in such a way that the plug ⑦ with the power cable ⑧ is on the right side (in direction of movement) (see fig.).

4. Attach connection cable ⑧ to the handle with the two cable clips ③.

5. Operation

Connecting extension cable:

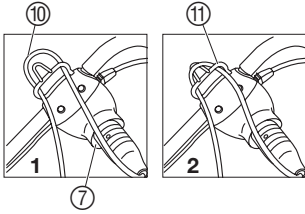

1. Push connector of extension cable ⑩ on to the plug ⑦.
2. Draw a loop of the extension cable ⑩ through the cable strain relief device ⑪ 1 and suspend in position 2.
This prevents inadvertent disconnection of the plug and socket connection.
3. Insert extension cable ⑩ into a mains socket.

Starting Electric Lawn Rake:



Danger of injury if the Electric Lawn Rake does not switch off automatically!

→ Do **not** remove or bridge safety devices fitted to the Electric Lawn Rake (e.g. by tying the starting lever to the upper handle)!

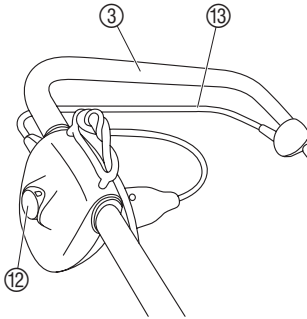

DANGER! The Electric Lawn Rake does not stop immediately after the motor has been switched off:

- **Never** lift, tip or carry the Electric Lawn Rake with the motor running!
- **Never** start on solid ground (e.g. asphalt).
- **Always** maintain the safety distance between the aerator cylinder and the user as defined by the guide handle.

1. Place Electric Lawn Rake on flat grass surface.
2. Keep safety interlock ⑫ pressed down and pull starting lever ⑬ on the upper handle ③. *The Electric Lawn Rake starts.*
3. Release safety interlock ⑫.

When in operation, the extension cable ⑩ must always be guided in the direction you are working and to the side of the area to be worked on.

Always work away from the connection cable.

Blockage Protection: If the aerator cylinder is blocked, e.g. by a foreign body, immediately release the starting lever. If the blockage lasts longer than 10 seconds and the starting lever has not been released, blockage protection is activated. In this case immediately release the starting lever. The Lawn Rake can be switched on again after cooling down for approx. 1 minute.

6. Maintenance



DANGER! The aerator cylinder can cause injuries!

- **Prior to maintenance, unplug from the mains and wait until the Electric Lawn Rake drum has stopped.**
- **Wear working gloves for performing maintenance.**

Cleaning Electric Lawn Rake:

The Electric Lawn Rake should be cleaned after each time it is used.

**Risk of injury and physical damage!**

- Do not clean Electric Lawn Rake under running water (particularly under high pressure).
- Do not use hard or pointed objects for cleaning the Electric Lawn Rake.

→ Remove grass and deposits from wheels, aerator cylinder and housing.

Adjusting for wear:

The Electric Lawn Rake is subject to wear in use due to the way in which it works. The more intensively the Electric Lawn Rake is used, the greater the wear on the spring tines. Hard or very dry ground accelerates wear as does excessive use of the Electric Lawn Rake.

If the results of your work with the Electric Lawn Rake become increasingly worse due to knife wear, the aerator cylinder can be adjusted twice.

The aerator cylinder has 4 adjustment positions:

- **Transport position**
- **Aerating position 1**
- **Aerating position 2:**

If the springs are worn (the rake roller is lowered by 3 mm).

• **Setting 3:**

Second setting for worn springs (the rake roller is lowered by a further 3 mm).

Push wear compensation lever ⑭ gently away from the housing and move to the position required.

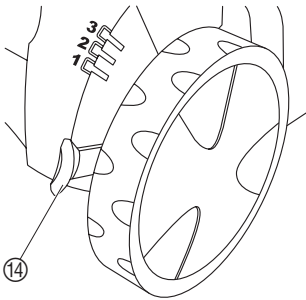

Note: Wear adjustment is not used for height adjustment. Adjustment of the aerator cylinder without visible wear can cause damage to the aerator cylinder or overload the motor.

7. Trouble-Shooting

Replacing spring tines:**DANGER! The aerator cylinder can cause injuries!**

- Prior to rectifying faults, unplug from the mains and wait until the aerator cylinder has stopped.
- Wear working gloves when rectifying faults.

If the aerator cylinder is not yet worn but individual springs have broken, these must be replaced. Only original **GARDENA replacement springs** may be used.

- **Replacement spring tines for Electric Lawn Rake GARDENA ES 500 Art. 4094**

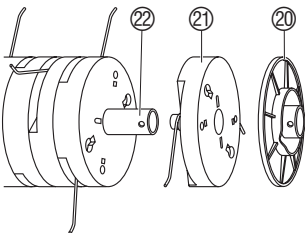
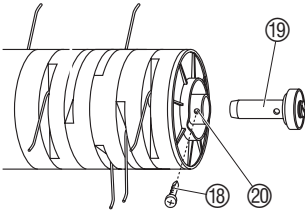
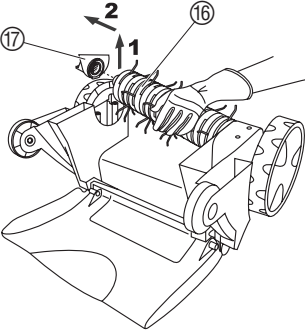
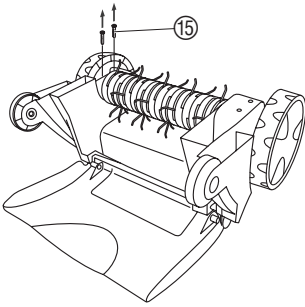

Problem

**Abnormal noise,
clattering in the unit**

Whistling sound

Possible Cause

Foreign bodies on the aerator cylinder are hitting the Rake.

Foreign bodies blocking the aerator cylinder.

Cogged belt slipping.

Remedy

1. Switch off the rake, remove the mains plug from the socket and wait until the cylinder has stopped rotating.

2. Remove foreign bodies.

3. Check Rake immediately.

→ Contact GARDENA Service.

1. Unscrew two screws ⑮ on the underside of the housing.
2. Lift aerator cylinder ⑯ at an angle 1 and pull away the drive shaft 2.
3. Pull bearing shell ⑰ off the aerator cylinder ⑯.
4. Unscrew and remove screw ⑱ and draw out bearing bolt ⑲.
5. Remove cover plate ⑳ and spring elements ㉑ from the spring element holder ㉒.
6. Push new spring elements ㉑ and cover plate ⑳ on the spring element holder ㉒.
The bores on the cover plate ⑳ and the spring element holder ㉒ must lie on top of each other.
7. Push in bearing bolt ⑲ in such a way that all 3 bores (bearing bolt ⑲, cover plate ⑳ and spring element holder ㉒) are on top of each other.
8. Screw in screw ⑱.
9. Push aerator cylinder ⑯ on to the drive shaft.
10. Put bearing shell ⑰ on the aerator cylinder ⑯.
11. Screw bearing shell ⑰ on to the lower side of the housing with the screw ⑮ without tightening too much.

Problem	Possible Cause	Remedy
Motor will not start	Faulty cable.	→ Check cable.
	The conductor cross-section of the extension cable is possibly too low.	→ Contact your electrician.
Motor cuts out because reblocking protection has been activated	Blocked by foreign bodies.	1. Switch off the motor, remove the mains plug from the socket and wait until the Rake has stopped rotating. 2. Remove foreign bodies. 3. After approx. 1 minute switch on the Rake.
	Aerating depth too large (aerator cylinder has been adjusted for wear without wear to the knives).	1. Leave motor to cool down. 2. Set adjustment for wear correctly.
	The grass is too tall.	→ Mow the lawn before aerating (see 3. Function "Correct Aerating").
Aerating results are not satisfactory	Wear to the spring tines.	→ Adjust aerator cylinder (see Maintenance).
	Cog belt faulty.	→ Contact GARDENA Service.
	Lawn has grown too tall.	→ Mow the lawn before using the Electric Lawn Rake.



In the event of other faults please contact GARDENA Service.
Repairs should only be carried out by GARDENA service centres or dealers authorised by GARDENA.

8. Storage

To put into storage:

To save space the Electric Lawn Rake can be folded up by releasing the wing nuts. **Take care during this process that the cable does not become trapped.**

→ Store the Electric Lawn Rake in a dry, closed room to which children cannot gain access.

Transport:

1. Switch off motor, unplug from the mains and wait until the aerator cylinder stops.
2. Move the wear compensation to the transport position and raise the Electric Lawn Rake when transporting it over sensitive surfaces, e.g. tiles.

Disposal:
(in accordance with
RL 2012/19/EC)



The product must not be added to normal household waste. It must be disposed of in line with local environmental regulations.

9. Accessories

10. Technical Data

Motor power consumption	500 W
Mains voltage	230 V
Mains frequency	50/60 Hz
Working speed of the aerator cylinder	2,250 r.p.m.
Weight	7.5 kg
Aerating width	30 cm
Wear adjustments	3 x 3 mm (3 adjustments + transport)
Working area related emission characteristic value L_{pA}¹⁾	77 dB (A)
Uncertainty k_{pA}	3 dB (A)
Noise level L_{WA}²⁾	measured 90 dB (A) / guaranteed 95 dB (A)
Uncertainty k_{WA}	5 dB (A)
Vibrations a_{vhw}¹⁾	≤ 2.5 m/s ²

Measuring method according to ¹⁾ EN 50636-2-92 ²⁾ Directive 2000/14/EC

11. Service/Warranty

Service:

Please contact the address on the back page.

Warranty:

GARDENA Manufacturing GmbH warrants this product for 2 years (from date of purchase). This warranty includes all significant defects of the product that can be proved to be material or manufacturing faults. Under warranty we will replace the product or repair it for no cost if these conditions are applicable:

- The product must have been used properly and in keeping with the requirements of the operation instructions.
- Neither the purchaser or a not approved third party have tried to repair the product.

This manufacturer's warranty does not have an effect on the user's existing warranty claims against the dealer/seller.

If you have problems with this product, please contact our Service or send the defective product together with a short description of the problem – if there is a warranty, with a copy of the receipt – postage paid to GARDENA Manufacturing GmbH.

Consumables:

The rake springs, are consumables and are not included in the warranty.

D Produkthaftung

Wir weisen ausdrücklich darauf hin, dass wir in Übereinstimmung mit dem Produkthaftungsgesetz nicht für Schäden haften, die durch unsere Erzeugnisse entstehen, wenn diese unsachgemäß repariert wurden oder wenn keine Originalteile von GARDENA oder zugelassene Teile verwendet wurden, und wenn die Reparaturen nicht von einem GARDENA Service-Center oder einem Fachhändler durchgeführt wurden. Entsprechendes gilt für Ergänzungsteile und Zubehör.

GB Product Liability

We expressly point out that, in accordance with the product liability law, we are not liable for any damage caused by our products if it is because of improper repair or if parts replaced are not original GARDENA parts or approved parts, and, if the repairs were not done by a GARDENA Service Centre or an approved specialist. The same applies to spare parts and accessories.

F Responsabilité

Nous vous signalons expressément que GARDENA n'est pas responsable des dommages causés par ses produits, dans la mesure où ces dommages seraient causés suite à une réparation non conforme, dans la mesure où, lors d'un échange de pièces, les pièces GARDENA d'origine ou approuvées n'auraient pas été utilisées, ou si la réparation n'a pas été effectuée par le service après-vente GARDENA ou l'un des Centres SAV agréés. Ceci est également valable pour tout ajout de pièces et d'accessoires autres que ceux préconisés par GARDENA.

NL Productaansprakelijkheid

Wij wijzen er nadrukkelijk op dat in overeenstemming met de wet voor productaansprakelijkheid wij niet aansprakelijk zijn voor enige schade veroorzaakt door onze producten als gevolg van onjuiste reparatie of als er onderdelen vervangen zijn door andere dan originele GARDENA-onderdelen of goedgekeurde onderdelen en als de reparaties niet zijn uitgevoerd door een GARDENA-servicecentrum of een goedgekeurde specialist. Ditzelfde geldt voor extra-onderdelen en accessoires.

S Produktansvar

Vi vill uttryckligen påpeka att, i enlighet med produktens ansvarsrätt, vi inte ansvarar för skada som orsakats av våra produkter om skadan beror på felaktig reparation eller om delar som byts ut inte är GARDENA-originaldelar eller godkända delar, och om reparationer inte har utförts av ett GARDENA-servicecenter eller en godkänd specialist. Samma sak gäller för kompletteringsdelar och tillbehör.

DK Produktansvar

Vi understreger udtrykkeligt, at vi i overensstemmelse med produktansvarsbestemmelserne ikke hæfter for skader forårsaget af vores produkter på grund af forkert reparation eller udskiftning af dele med uoriginale GARDENA-komponenter eller komponenter, som ikke er godkendt af os, og hvis reparationer ikke er udført af et GARDENA-servicecenter eller en godkendt specialist. Det samme gælder for ekstra udstyr og tilbehør.

FI Tuotevastuu

Ilmoitamme erityisesti, että tuotevastuulain mukaisesti emme ole vastuussa tuotteiden vaurioista, jos niiden syynä on virheellinen korjaaminen tai muiden kuin alkuperäisten GARDENA-varaosien tai hyväksytyjen varaosien käyttö tai jos korjauksia ei ole tehnyt GARDENA-huoltoliike tai valtuutettu asiantuntija. Tämä pätee myös lisäosiin ja lisävarusteisiin.

I Responsabilità del prodotto

Si rende espressamente noto che, conformemente alla legislazione sulla responsabilità del prodotto, non si risponde di danni causati da nostri prodotti se originati da riparazioni eseguite non correttamente o da sostituzioni di parti effettuate con materiale non originale GARDENA o comunque da noi non approvato e, in ogni caso, qualora l'intervento non venga eseguito da un centro assistenza GARDENA o da personale specializzato autorizzato. Lo stesso vale per le parti complementari e gli accessori.

E Responsabilidad de productos

Advertimos expresamente que, de acuerdo con la ley de fiabilidad del producto, no nos hacemos responsables de ningún daño causado por nuestros productos si es el resultado de una reparación incorrecta, si las piezas de recambio no son piezas originales de GARDENA o piezas homologadas, o si la reparación no la ha realizado un centro de servicio de GARDENA o un especialista autorizado. Lo mismo es aplicable para las piezas complementarias y accesorios.

P Responsabilidade sobre o produto

Relembremos expressamente que, em conformidade com a lei de responsabilidade pelo produto, não nos responsabilizamos por quaisquer danos causados pelos nossos produtos se forem provocados por reparações inadequadas ou se as peças substituídas não forem peças GARDENA originais ou peças aprovadas e se as reparações não tiverem sido realizadas por um centro de assistência GARDENA ou por um especialista aprovado. Esta restrição valerá também para peças adicionais e acessórios.

PL Odpowiedzialność za produkt

Wyraźnie zwracamy uwagę, że zgodnie z obowiązującymi przepisami nie ponosimy odpowiedzialności za żadne szkody spowodowane przez nasze produkty, jeśli doszło do nich w wyniku niewłaściwej naprawy lub użycia nieoryginalnych bądź niezatwierdzonych części zamiennych GARDENA i jeśli naprawy nie zostały przeprowadzone przez centrum serwisowe GARDENA lub autoryzowanego specjalistę. Dotyczy to również części uzupełniających i oprzyrządowania.

H Termékszavatosság

Nyomatékosan utalunk arra a tényre, hogy a termékszavatossági törvény szerint nem kell jótállást vállalnunk azokra a károokra, amelyeket nem a mi készülékeink okoztak, ha ezeket szakszerűtlen javítás okozta vagy egy alkatrész kicserélésénél nem a mi eredeti GARDENA alkatrészeinket vagy általunk engedélyezett alkatrészeket használták fel és a javítást nem a GARDENA szerviz vagy egy erre felhatalmazott szakember végezte. Hasonlóképpen érvényes ez a kiegészítő alkatrészekre és tartozékokra is.

CZ Odpovědnost za výrobek

Výslovně upozorňujeme na to, že podle zákona o odpovědnosti za výrobek neneseme odpovědnost za škody způsobené našimi přístroji, pokud byly způsobené neodbornou opravou nebo použitím jiných než našich originálních náhradních dílů GARDENA nebo námi schválených dílů a neprovedením opravy servisem GARDENA nebo autorizovaným odborníkem. Odpovídající platí i pro doplňkové díly a příslušenství.

SK Predmet záruky

Upozorňujeme dôrazne na to, že podľa zákona o poskytovaní záruk nezodpovedáme za škody spôsobené našimi výrobkami, v prípade, že boli boli vyvolané neodbornými opravami, výmenou dielcov, ktoré nepatria k originálnym dielom GARDENA alebo neboli nami schválené rovnako boli spôsobené servisnými zásahmi, ktoré neboli vykonané servisom GARDENA alebo autorizovaným odborníkom. Rovnako to platí pre doplnky a príslušenstvo.

GR Ευθύνη για το προϊόν

Σας υπενθυμίζουμε ρητά, ότι σύμφωνα με το νόμο περί ευθύνης για τα προϊόντα δεν ευθυνόμαστε για ενδεχόμενες βλάβες που προκαλούνται από τις συσκευές μας, εφόσον οφείλονται σε μία ακατάλληλη επισκευή ή σε μια αντικατάσταση τμημάτων για την οποία δεν έχουν χρησιμοποιηθεί τα πρωτότυπα ανταλλακτικά της GARDENA ή τα από μας συγκεκριμένα ανταλλακτικά και σε περίπτωση που δεν εκτελείται η επισκευή από το Τμήμα Εξυπηρέτησης Πελατών της GARDENA ή από έναν εξουσιοδοτημένο εξειδικευμένο τεχνίτη. Το ίδιο ισχύει για εξαρτήματα και συμπληρωματικά τμήματα.

SLO Jamstvo za izdelek

Izrecno izjavljamo, v skladu z ustreznimi zakonodajo, ki ureja odgovornost proizvajalca, da ne prevzemamo nikakršne odgovornosti za poškodbe, ki bi jih naši izdelki povzročili zaradi neustreznega popravila ali uporabe neoriginalnih ali neodobrenih nadomestnih delov (ki jih ne izdelata podjetje GARDENA) ali če popravil ne bi opravil servisni center GARDENA ali pooblaščen specialist. Enako velja tudi za nadomestne dele in opremo.

HR Odgovornost za proizvod

Izričito naglašavamo kako, u skladu sa zakonom o odgovornosti za proizvode, nismo odgovorni za bilo koja oštećenja uzrokovana našim proizvodima ako su posljedica nepravilnog popravka ili zamjene dijelova s neoriginalnim dijelovima ili dijelovima bez odobrenja tvrtke GARDENA i ako popravci nisu provedeni u servisnom centru tvrtke GARDENA ili ako ih nije proveo odobreni stručnjak. Isto vrijedi i za dodatne dijelove i pribor.

RO Responsabilitatea legala a produsului

Mentionăm în mod expres că, în conformitate cu legea privind răspunderea pentru produs, nu suntem răspunzători pentru nicio deteriorare provocată de produsele noastre, dacă se datorează reparării necorespunzătoare sau dacă piesele înlocuite nu sunt piese originale GARDENA sau piese aprobate și dacă reparațiile nu au fost efectuate de un Centru de service GARDENA sau de un specialist autorizat. Aceleași prevederi se aplica și pieselor de schimb si accesoriilor.

BG Отговорност за качество

Ние изрично посочваме, че в съответствие със закона за отговорността за продукта не носим отговорност за повреди, причинени от нашите продукти, ако това се дължи на неправилен ремонт или ако заменените части не са оригинални части на GARDENA или одобрени части, или ако ремонтните дейности не са били извършени от сервизен център на GARDENA или от одобрен специалист. Същото важи за допълнителните части и принадлежности.

EST Tootevastutus

Me teatame sõnaselgelt, et vastavalt tootevastutuse seadusele ei vastuta me mis tahes meie toodete põhjustatud kahjude eest, mis on tekkinud toote ebaõige parandamise tõttu või varuosadena GARDENA mitte-originaalvaruosade või heakskiidetud varuosade kasutamise tõttu või parandustööde tegemise tõttu mujal kui GARDENA hoolduskeskuses või heakskiidetud spetsialisti juures. Sama kehtib lisadetailide ja tarvikute kohta.

LT Atsakomybė už produkciją

Mes aiškiai pareiškiamo, kad atsižvelgiant į gaminių patikimumo įstatymą nepriisiame atsakomybės dėl bet kokios žalos, patirtos dėl mūsų gaminių, jeigu jie buvo netinkamai taisomi arba jų dalys buvo pakeistos neoriginaliomis GARDENA dalimis ar nepatvirtintomis dalimis, arba jeigu remonto darbai buvo atliekiami ne GARDENA techninės priežiūros centro specialistų. Tas pats galioja papildomoms dalims ir priedams.

LV Produkta atbildība

Mēs skaidri norādām uz to, ka saskaņā ar Produktu atbildības likumu, mēs neatbildam par mūsu iekārtu radītiem zaudējumiem, ciktāl tos ir izraisījis neatbilstošs remonts vai daļu nomaiņa ar neoriģinālām GARDENA daļām vai ne ar mūsu norādītajām detaļām un remontu nav veicis GARDENA serviss vai pilnvarots speciālists. Tas pats attiecas uz papildinošajām daļām un piederumiem.

<p>D CE-Conformit�tserkl�ring Der Unterzeichnete Husqvarna AB, 561 82 Huskvarna, Sweden best�tigt, dass die nachfolgend bezeichneten Ger�te in der von uns in Verkehr gebrachten Ausf�hrung die Anforderungen der harmonisierten EU-Richtlinien, EU-Sicherheitsstandards und produktspezifischen Standards erf�llen. Bei einer nicht mit uns abgestimmten �nderung der Ger�te verliert diese Erkl�rung ihre G�ltigkeit.</p>	<p>H EU-Megfelol�s�gi nyilatkozat Alulr�tt, a Husqvarna AB, 561 82 Huskvarna, Sweden igazolja azt, hogy az al�ltalban megnevezett k�szl�vek, az �ltalunk forgalomba hozott k�vitelben teljesitik a harmoniz�ci�s EU-ir�nyelvek, az EU biztons�gi szabv�nyok �s a term�kre jellemz� szabv�nyok k�vetelm�nyeit. Ha a k�szl�veken a mi beleegyez�s�nk n�lk�l v�ltoztat�st v�geznek, akkor ez a nyilatkozat �rvenyt veszti.</p>
<p>GB CE Declaration The undersigned Husqvarna AB, 561 82 Huskvarna, Sweden hereby certifies that, when leaving our factory, the units indicated below are in accordance with the harmonised EU guidelines, EU standards of safety and product specific standards. This certificate becomes void if the units are modified without our approval.</p>	<p>CZ Prohl�šení o shod� EU Podepsan� Husqvarna AB, 561 82 Huskvarna, Sweden potvrzuje, že d�le uveden� p�stroje v n�m� do provozu uveden�m proveden� spln�j� p�žadavky harmonizovan�ch sm�rnice EU, bezpe�nostn�ch norem EU a norem specifick�ch pro v�robek. P�i n�m� neschv�len� zm�n� p�stroj� ztr�c� toto prohl�šení platnost.</p>
<p>F Certificat de conformit� aux directives europ�ennes Le constructeur, soussign� : Husqvarna AB, 561 82 Huskvarna, Sweden d�clare qu'� la sortie de ses usines le mat�riel neuf d�sign� ci-dessous �tait conforme aux prescriptions des directives europ�ennes �nonc�es ci-apr�s et conforme aux r�gles de s�curit� et autres r�gles qui lui sont applicables dans le cadre de l'Union europ�enne. Toute modification port�e sur ce produit sans l'accord express de GARDENA supprime la validit� de ce certificat.</p>	<p>SK EU-Vyhlasenie o zhode Ni�šie uveden� firma Husqvarna AB, 561 82 Huskvarna, Sweden vyhlasuje, že uveden� zariadenia, ktor� uviedla na trh v tomto vyhotoven�, spln�j� p�žadavky harmonizovan�ch smernic EU, bezpe�nostn�ch noriem EU a noriem specifick�ch pre v�robok. Pri zmene zariadenia, ktor� nebola ods�hlasen� v�robcom stráca toto vyhl�senie platnost.</p>
<p>NL EU-overeenstemmingsverklaring Ondergetekende Husqvarna AB, 561 82 Huskvarna, Sweden bevestigt, dat de volgende genoemde apparaten in de door ons in de handel gebrachte uitvoering voldoen aan de eis van, en in overeenstemming zijn met de EU-richtlijnen, de EU-veiligheidsstandaard en de voor het product specifieke standaard. Bij een niet met ons afgestemde verandering aan de apparaten verliest deze verklaring haar geldigheid.</p>	<p>GR D�hlωση Συμm�ρφωσης προς τις Οδηγίες της ΕΕ Η υπογράφουσα Husqvarna AB, 561 82 Huskvarna, Sweden δηλώνει, ότι τα ερζη αναφερόμενα εκδιδόμενα από την εταιρία μας προϊόντα ανταποκρίνονται σε όλες τις αναρρηγομένης προδιαγραφές της ΕΕ, στα πρότυπα ασφαλείας της ΕΕ και στα ειδικά για το προϊόν πρότυπα. Σε μία μη συμφωνημένη με την εταιρία μας τροποποίηση των συσκευίων αυτή η δήλωση χάνει την ισχύ της.</p>
<p>S EU Tillverkarintyg Undertecknad firma Husqvarna AB, 561 82 Huskvarna, Sweden intygar h�rmed att nedan n�mnda produkter �verensst�mmer med EU:s direktiv, EU:s s�kerhetsstandard och produktspecifikation. Detta intyg upph�r att g�lla om produkten �ndras utan v�rt tillst�nd.</p>	<p>SLO EU-izjava o skladnosti Podpisani proizvajalec »Husqvarna AB, 561 82 Huskvarna, Sweden« s podpisom potrjuje, da slede�e opisana naprava, ki smo jo poslali na tr�i�ce izpolnjuje zahteve harmoniziranih standardov ES-smernic, ES-varnostnih standardov in izdelku specifi�nih standardov. V primeru spremembe na napravi brez na�ega posebnega dovoljenja ta izjava izgubi svoj pomen in veljavnost.</p>
<p>DK EU Overensstemmelse certificat Undertegnede Husqvarna AB, 561 82 Huskvarna, Sweden bekr�fter hermed, at enheder listet herunder, ved afsendelse fra fabrikken, er i overensstemmelse med harmoniserede EU retningslinier, EU sikkerheds standarder og produkt specifikations standarder. Dette certificat tr�der ud af kraft hvis enhederne er �ndret uden vor godkendelse.</p>	<p>HR Izjava o skladnosti EU-a Dolje potpisana tvrtka Husqvarna AB, 561 82 Huskvarna, Sweden ovime potvrđuje da dolje navedeni uređaji u izvedbi plasiranoj na tr�i�ce ispunjavaju zahtjeve harmoniziranih EU smjernica, EU sigurnosnih normi i normi za odredene proizvode. Ova izjava postaje ništava u slucaju izmjene uređaja koje nismo odobrili.</p>
<p>FI EU-yhdenmukaisuuskvakuutus Allekirjoittanut Husqvarna AB, 561 82 Huskvarna, Sweden vakuuttaa, ett� allainnimitet laittees t�ytt�v�t tehtaatamme l�htiesiss�n yhdenmukaistetujen EU-direktiivien, EU-turvallisuusstandardien ja tuotekohtaisten standardien vaatimukset. Laitteisiin tehdyt muutokset, joista ei ole sovittu kanssamme, johtavat t�m�n vakuutuksen raukaamiseen.</p>	<p>RO UE-Certificat de conformitate Prin prezenta Husqvarna AB, 561 82 Huskvarna, Sweden, certifica faptul ca, in momentul in care produsele mentionate mai jos ies din fabrica sunt in concordanta cu directivele UE, standardele de siguranta UE si standardele specifice ale produsului UE. Acest certificat devine nul in cazul modificarii aparatului f�r� aprobarea noastr�.</p>
<p>I Dichiarazione di conformit� alle norme UE La sottoscritta Husqvarna AB, 561 82 Huskvarna, Sweden certifica che il prodotto qui di seguito indicato, nei modelli da noi commercializzati, � conforme alle direttive armonizzate UE nonch� agli standard di sicurezza e agli standard autorizzatori di prodotto. Qualunque modifica apportata al prodotto senza nostra specifica autorizzazione invalida la presente dichiarazione.</p>	<p>BG EC-Декларация за съответствие Подписаната фирма Husqvarna AB, 561 82 Huskvarna, Sweden декларира, че описаните по-долу уређи, пунати в продажба съгласно нашата спецификация, изпълняват изискванията на хармонизираните ЕС-директиви, ЕС-станданти за безопасност и специфичните производствени стандарти. При промяна на уређа, която не е съгласувана с нас, тази декларация губи своята валидност.</p>
<p>E Declaraci�n de conformidad de la UE El que suscribe Husqvarna AB, 561 82 Huskvarna, Sweden declara que la presente mercanc�a, objeto de la presente declaraci�n, cumple con todas las normas de la UE, en lo que a normas t�cnicas, de homologaci�n y de seguridad se refiere. En caso de realizar cualquier modificaci�n en la presente mercanc�a sin nuestra previa autorizaci�n, esta declaraci�n pierde su validez.</p>	<p>EST ELi vastavusdeklaratsioon Allkirjutan Husqvarna AB, 561 82 Huskvarna, Sweden kinnitab, et kirjeldatud seade vastab meie poolt riiglusse viidud kujul ELi harmoniseeritud direktiividele, ELi ohutusstandarditele ja tootega seotud standarditele. Meiega koost�astamata muudatuse tegemise korral seadmel kaotab see deklaratsioon kehtivuse.</p>
<p>P Certificado de conformidade da UE Os abaixo mencionados Husqvarna AB, 561 82 Huskvarna, Sweden, por este meio certificam que ao sair da f�brica os aparelhos abaixo mencionados est�o de acordo com as directrizes harmonizadas da UE, padr�es de seguran�a e de produtos especifcos. Este certificado ficar� nulo se as unidades forem modificadas sem a nossa aprova�o.</p>	<p>LT ES Atitikties deklaracija Pasira�anti imon� Husqvarna AB, 561 82 Huskvarna, Sweden patvirtina, kad �emiau nurodyti prietaisai ir jų modeliai, kurie buvo pagaminti mūsų gamykloje atitinka ES direktyvas, ES saugumo standartus ir specifinius gaminio standartus. Atlikus bet k�kį prietaiso pakeitim�, kuris n�ra suderintas su mumis, ši deklaracija praranda galiojim�.</p>
<p>PL Deklaracja zgodno�ci Unii Europejskiej Husqvarna AB, 561 82 Huskvarna, Sweden potwierdza, że poni�ej okre�lone urz�dzenia w wersji oferowanej przez nas do sprzedazy spehniaj� wymagania zharmonizowanych dyrektyw Unii Europejskiej, standardu bezpiecze�stwa Unii Europejskiej i standardu specyficznego dla tego typu produkt�w. W przypadku zmiany urz�dzenia, kt�ra nie zostala z nami uzgodniona, niniejsza deklaracja traci moc obowi�zawania.</p>	<p>LV ES-atbilstības deklaracija Parakstijies Husqvarna AB, 561 82 Huskvarna, Sweden, V�cija apstiprina, ka sekojo�i apzīm�tās iek�rtas, kuras m�s izplat�m, sav� izpildījum� atbilst harmoniz�tajam ES direktiv�m, ES dro�ibas standartiem un produkta specifiskajiem standartiem. Ar m�su neapstiprin�tam izmaiņ�m iek�rt� ši deklar�cija zaud� savu derīgumu.</p>

<p>Bezeichnung des Geräts: Description of the unit: Désignation du matériel : Omschrijving van de apparaten: Produktbeskrivning: Beskrivelse af produktet: Laitteiden nimitys: Descrizione dei prodotti: Descripción de la mercancía: Descrição dos aparelhos: Nazwa urządzenia: A készülékek megnevezése: Označení přístrojů: Označenie zariadenia: Όνομασία της συσκευής: Όψis naprave: Oznaka uređaja: Descrierea articolelor: Обозначение на уредите: Seadméte nimetus: Prietaisų pavadinimas: Iekārtu apzīmējums:</p>	<p>Elektro-Rasenlüfter Electric Lawn Rake Aérateur électrique Elektrische gazonbeluchter Elektrisk Gräsmatteluftare Elektrisk Plænelufter Sähkökätöinen ilmastointilaitte Arieggiatore elettrico Aireador de césped eléctrico Arejador de relva eléctrico Elektryczny aerator Elektrómos gypszellőztető Elektrický prevzdušňovač Elektrický prevzdušňovač Ηλεκτρικός εξεραωτής γκαζόν Elektricióni prezračevalnik trate Elektricióni prozračivač Aerator electric Електрическо гребло за трева Elektriline murureha Elektrinis samanų grėblys Elektriskais zāļāju grābeklis</p>	<p>Schall-Leistungspegel: Noise level: Puissance acoustique : Geluidsniveau: Ljudnivå: Lydytrąksnivau: Melun tehotos: Livello rumorosità: Nivel sonoro: Nivel de ruido: Poziom natężenia dźwięku: Zajletjestiměny szint: Hluková hladina výkonu: Επίπεδο ισχύος ήχου: Nivo hrupa: Razina zvúčne snage Nivel de putere acustică: Ниво на шума: Helivõimsuse tase: Garso stiprumo lygis: Troksņu jaudas līmenis:</p>	<p>gemessen/ garantiert measured/ guaranteed mesurée/ garantie gemeten/ gegarandeerd uppmått/ garantierad afmålt/ garanti mituttu/ taattu testato/ garantito medido/ garantizado medido/ garantido zmierzono/ gwarantowane mért/ garantált naměřeno/ garantováno meraná/ garantovaná μετρήθηκαν/ εγγυημένα izmerjeno/ zagotovljeno izmerjeno/ garantirano măsurat/ garantat измерено/ гарантирано mõõdetud/ garanteeritud išmatuotas/ garantuotas izmērtais/ garantētais</p>
90 dB (A)/95 dB (A)			
<p>Typ-Bezeichnung: Product type: Désignation du modèle: Type-aanduiding: Typbeteckning: Type-betegnelse: Typipukkuvaus: Tipologia: Designación del tipo: Designação do modelo: Oznaczenie typu:</p>	<p>Tipus megnevezése: Typové označení: Typ-označenie: Όνομασία τύπου: Naziv tipa: Oznaka tipa: Denumirea tipului: Тип-наименование: Tíubi nimetus: Tipo pavadinimas: Tipa apzīmējums:</p>	<p>Artikel-Nummer: Article-Number: Référence : Artikelnummer: Ref.-nummer: Tuetteno: Numero articolo: Número de artículo: Número de referencia: Cikkszám: Číslo výrobku: Číslo výrobku: Κωδικός: Številka artikla: Broj artikla: Număr articol: Артикул номер: Artikli number: Gaminio numeris: Preces numurs:</p>	<p>Anbringungsjaar der CE-Kennzeichnung: Year of CE marking: Année d'apposition du marquage CE : Installatiejaar van de CE-aanduiding: Märkningsår: CE-Mærkningsår: CE-merkin kiinnitysvuosi: Anno di applicazione della certificazione CE: Colocación del distintivo CE: Ano de marcação pela CE: Rok nadania oznakowania CE: CE-jelzés elhelyezésének éve: Rok umístění značky CE: Rok udelenia značky CE: Έτος σήματος CE: Leto namestitve CE-oznake: Godina dobivanja CE oznake:</p>
ES 500	4066		
<p>CE-Richtlijnen: CE-Directives: Directives CE : CE-richtlijnen: CE-direktiv: CE-direktiver: CE-merkinnät: Directive CE: Directivas CE: Diretivas CE: Dyrektywy CE: CE irányelvek: Směrnice CE: Označenie CE: Όδηγίες CE: CE-direktive: CE směrnice: Directive CE: CE-Директиви: CE direktiivid:</p>	<p>CE direktyvos: CE direktivas:</p>	<p>2000/14/EG 2006/42/EG 2014/30/EG 2011/65/EG</p>	<p>Anul de marcare CE: Година на поставяне на CE-маркировка: CE-märkgistuse paigaldamise aasta: Metai, kada pažymėta CE-ženklui: CE-marčkjuma uzliškšanas gads: 2004</p>
<p>Harmonisierte EN: / Harmonised EN:</p>	<p>EN 60335-1 EN 50636-2-92 EN ISO 12100</p>		
<p>Hinterlegte Dokumentation: GARDENA Technische Dokumentation, M. Kugler, 89079 Ulm Deposited Documentation: GARDENA Technical Documentation, M. Kugler, 89079 Ulm Documentation déposée: Documentation technique GARDENA, M. Kugler, 89079 Ulm</p>	<p>Conformitätsbewertungsverfahren: Nach 2000/14/EG Art. 14 Anhang V Conformity Assessment according to: 2000/14/EC Procedure: art. 14 Annex V Procédure d'évaluation de la conformité: Selon 2000 /14 /CE art. 14 Annexe V</p> <p>Ulm, den 07.12.2016 Ulm, 07.12.2016 Fait à Ulm, le 07.12.2016 Ulm, 07-12-2016 Ulm, 2016.12.07. Ulm, 07.12.2016 Ulmmissa, 07.12.2016 Ulm, 07.12.2016 Ulm, 07.12.2016 Ulm, 07.12.2016 Ulm, dnia 07.12.2016 Ulm, 07.12.2016 Ulm, 07.12.2016 Ulm, 07.12.2016 Ulm, 07.12.2016 Ulm, 07.12.2016 Ulm, 07.12.2016 Ulm, 07.12.2016 Ulm, 07.12.2016 Ulm, 07.12.2016 Ulm, 07.12.2016 Ulm, 07.12.2016 Ulm, 07.12.2016 Ulm, 07.12.2016 Ulm, 07.12.2016 Ulm, 07.12.2016 Ulm, 07.12.2016</p> <p>Der Bevollmächtigte Authorized representative: Le mandataire De gevolmachtigde Auktoriserad representant Autoriseret repræsentant Valtuutettu edustaja Persona delegata La persona autorizada O representante Pelnomocnik Meghatalmazott Zplnomocněnc Splnomocnený O εξουσιοδοτημένος Pooblaščenec Ovlaštena osoba Conducerea tehnică Упълномощен Volitatud esindaja Įgaliotasis atstovas Pilnvarotā persona</p> <p><i>Reinhard Pompe</i> Reinhard Pompe (Vice President)</p>		

Deutschland / Germany

GARDENA
Manufacturing GmbH
Central Service
Hans-Lorenser-Straße 40
D-89079 Ulm
Produktfragen:
(+49) 731 490-123
Reparaturen:
(+49) 731 490-290
service@gardena.com

Albania

COBALT Sh.p.k.
Rr. Siri Kodra
1000 Tirana

Argentina

Husqvarna Argentina S.A.
Av.del Libertador 5954 –
Piso 11 – Torre B
(C1428ARP) Buenos Aires
Phone: (+54) 11 5194 5000
info.gardena@
ar.husqvarna.com

Armenia

Garden Land Ltd.
61 Tigran Mets
0005 Yerevan

Australia

Husqvarna Australia Pty. Ltd.
Locked Bag 5
Central Coast BC
NSW 2252
Phone: (+61) (0) 2 4352 7400
customer.service@
husqvarna.com.au

Austria / Österreich

Husqvarna Austria GmbH
Industriezeile 36
4010 Linz
Tel.: (+43) 732 7701 01-485
service.gardena@
husqvarnagroup.com

Azerbaijan

Firm Progress
a. Aliyev Str. 26A
1052 Baku

Belgium

Husqvarna België nv/sa
Gardena Division
Rue Egide Van Opthem 111
1180 Uccle / Ukkel
Tel.: (+32) 2 720 92 12
info@gardena.be

Bosnia / Hercegovina

SILK TRADE d.o.o.
Industrijska zona Bukva bb
74260 Tešanj

Brazil

Husqvarna do Brasil Ltda
Av. Francisco Matrazzo,
1400 – 19º andar
São Paulo – SP
CEP: 05001-903
Tel: 0800-112252
marketing.br.husqvarna@
husqvarna.com.br

Bulgaria

AGROLAND България АД
бул. 8 Декември, №13
Офис 5
1700 Студентски град
София
Тел.: (+359) 2466 69 10
info@agroland.eu

Canada / USA

GARDENA Canada Ltd.
100 Summerlea Road
Brampton, Ontario L6T 4X3
Phone: (+1) 905 792 93 30
info@gardenacanada.com

Chile

Maquinarias Agroforestales
Ltda. (Maga Ltda.)
Santiago, Chile
Avda. Chesterton
8355 comuna Las Condes
Phone: (+56) 2 202 4417
Dalton@мага.cl
Zipcode: 7560330

China

Husqvarna (China) Machinery
Manufacturing Co., Ltd.
No. 1355, Jia Xin Rd.,
Ma Lu Zhen, Jia Ding Dist.,
Shanghai
201801
Phone: (+86) 21 59159629
Domestic Sales
www.gardena.com.cn

Colombia

Husqvarna Colombia S.A.
Calle 18 No. 68 D-31, zona
Industrial de Montevideo
Bogotá, Cundinamarca
Tel. 571 2922700 ext. 105
jairo.salazar@
husqvarna.com.co

Costa Rica

Compania Exim
Euroiberoamericana S.A.
Los Colegios, Moravia,
200 metros al Sur del Colegio
Saint Francis – San José
Phone: (+506) 297 68 83
exim_euro@racsa.co.cr

Croatia

SILK ADRIA d.o.o.
Josipa Lončara 3
10090 Zagreb
Phone: (+385) 1 3794 580
silk.adria@zg.t-com.hr

Cyprus

Med Marketing
17 Digeni Akrita Ave
P.O. Box 27017
1641 Nicosia

Czech Republic

Husqvarna Česko s.r.o.
Türkova 2319/5b
149 00 Praha 4 – Chodov
Bezplatná infolinka:
800 100 425
servis@cz.husqvarna.com

Denmark

GARDENA DANMARK
Lejrvvej 19, st.
3500 Værløse
Tlf.: (+45) 70264770
husqvarna@husqvarna.dk
www.gardena.com/dk

Dominican Republic

BOSQUESA, S.R.L.
Carretera Santiago Licey
Km. 5 ½
Esquina Copal II,
Santiago
Dominican Republic
Phone: (+809) 736-0333
joserbosquesa@claro.net.do

Ecuador

Husqvarna Ecuador S.A.
Arujos E1-181 y 10 de
Agosto Quito, Pichincha
Tel. (+593) 22800739
francisco.jacome@
husqvarna.com.ec

Estonia

Husqvarna Eesti OÜ
Gardena Division
Valdeku 132
Tallinn
Phone: (+372) 2466 69 10
info@gardena.ee

Finland

Oy Husqvarna Ab
Gardena Division
Lautarhankatu 8 B / PL 3
00581 HELSINKI
info@gardena.fi

France

Husqvarna France
9/11 Allée des pierres mayettes
92635 Gennevilliers Cedex
France
http://www.gardena.com/fr
N° AZUR: 0 810 00 78 23
(Prix d'un appel local)

Georgia

ALP Group
Belashvili 8
1159 Tbilisi

Great Britain

Husqvarna UK Ltd
Preston Road
Aycliffe Industrial Park
Newton Aycliffe
County Durham
DL5 6UP
info.gardena@
husqvarna.co.uk

ГРЕЦΙΑ

Π.Ε.ΠΑΠΑΔΟΠΟΥΛΟΣ ΑΕΒΕ
Λεωφ. Αθηνών 92
Αθήνα
T.K. 104 2
Ελλάδα
Τηλ. (+30) 210 5193 100
info@papadopoulos.gr

Hungary

Husqvarna Magyarország Kft.
Ezred u. 1-3
1044 Budapest
Telefon: (+36) 1 251-4161
vevoszolgalat.husqvarna@
husqvarna.hu

Iceland

Ó. Johnson & Kaaber
Tunguhalis 1
110 Reykjavik
ojj@ojk.is

Ireland

Husqvarna UK Ltd
Preston Road
Aycliffe Industrial Park
Newton Aycliffe
County Durham
DL5 6UP
info.gardena@
husqvarna.co.uk

Italy

Husqvarna Italia S.p.A.
Via Santa Vecchia 15
23868 VALMADRERA (L.C.)
Phone: (+39) 0341.203.111
assistenza.italia@
it.husqvarna.com

Japan

KAKIUCHI Co. Ltd.
Sumitomo Realty &
Development Kojimachi
BLDG., 8F
5-1 Nibanncyo
Chiyoda-ku
Tokyo 102-0084
Phone: (+81) 33 264 4721
m_ishihara@kaku-ichi.co.jp

Kazakhstan

LAMED Ltd.
155/1, Tazhibayevoy Str.
050060 Almaty
Alf Schmidt
Abayavenue 3B
110 005 Kostanay

Korea

Kyung Jin Trading CO., LTD.
107-4, SunDuk Bld.,
YangJae-dong,
Seochu-gu,
Seoul, (zipcode: 137-891)
Phone: (+82) (0)2 574-6300

Kyrgyzstan

Alye Maki
av. Moladaya Guardir J 3
720014
Bishkek

Latvia

Husqvarna Latvija SIA
Gardena Division
Ulbrokas 19A
LV-1021 Riga
info@gardena.lv

Lithuania

UAB Husqvarna Lietuva
Gardena Division
Atleities pl. 77C
LT-52104 Kaunas
info@gardena.lt

Luxembourg

Magasins Jules Neuberg
339, rue Jacques Stas
Luxembourg-Gasperich 2549
Case Postale No. 12
Luxembourg 2010
Phone: (+352) 40 14 01
api@neuberg.lu

Mexico

AFOSA
Av. Lopez Mateos Sur # 5019
Col. La Calma 45070
Zapopan, Jalisco
Mexico
Phone: (+52) 33 3818-3434
icornejo@afosa.com.mx

Moldova

Comvel S.R.L.
290 A Muncest Str.
2002 Chisinau

Netherlands

Husqvarna Nederland B.V.
GARDENA Division
Postbus 50131
1305 AC ALMERE
Phone: (+31) 36 521 00 10
info@gardena.nl

Neth. Antilles

Jonka Enterprises N.V.
Sta. Rosa Weg 196
P.O. Box 8200
Curaçao
Phone: (+599) 9 767 66 55
pgm@jonka.com

New Zealand

Husqvarna New Zealand Ltd.
PO Box 76-437
Manukau City 2241
Phone: (+64) (0) 9 9202410
support.nz@husqvarna.co.nz

Norway

Husqvarna Norge AS
Gardena Division
Trøskenveien 36
1708 Sarpsborg
Tel: 69 10 47 00
www.gardena.no

Peru

Husqvarna Perú S.A.
Jr. Ramón Cárcamo 710
Lima 1
Tel: (+51) 1 3320400 ext. 416
juan.remuzgo@
husqvarna.com

Poland

Husqvarna
Poland Spółka z o.o.
ul. Wysockiego 15 b
03-371 Warszawa
Phone: (+48) 22 330 96 00
gardena@husqvarna.com.pl

Portugal

Husqvarna Portugal, SA
Lagoa – Albarraque
2635 – 595 Rio de Mouro
Tel.: (+351) 21 922 85 30
Fax: (+351) 21 922 85 36
info@gardena.pt

Romania

Madex International Srl
Soseaua Odaii 117-123,
RO 013603 Bucuresti, S 1
Phone: (+40) 21 352.76.03
madex@mes.ro

Russia / Россия

ООО „Хускварна“
141400, Московская обл.,
г. Химки,
улица Ленинградская,
владение 39, стр.6.
Бизнес Центр
„Химки Бизнес Парк“,
помещение 0B02.04
http://www.gardena.ru

Serbia

Domet d.o.o.
Autoput za Novi Sad bb
11273 Belgrade
Phone: (+381) 118 488 88 12
miroslav.jejina@domet.rs

Singapore

Hy-Ray PRIVATE LIMITED
40 Jalan Pemimpin
#02-09 Tat Ann Building
Singapore 577185
Phone: (+65) 6253 2277
shying@hyray.com.sg

Slovak Republic

Husqvarna Cesko s.r.o.
Türkova 2319/5b
149 00 Praha 4 – Chodov
Bezplatná infolinka:
800 154 044
servis@sk.husqvarna.com

Slovenia

Husqvarna Austria GmbH
Industriezeile 36
4010 Linz
Tel.: (+43) 732 77 01 01-485
service.gardena@
husqvarnagroup.com

South Africa

Husqvarna
Husqvarna (Pty) Ltd
Postnet Suite 250
Private Bag X6,
Cascades, 3202
South Africa
Phone: (+27) 33 846 9700
info@gardena.co.za

Spain

Husqvarna España S.A.
Calle de Rivas n° 10
28052 Madrid
Phone: (+34) 91 708 05 00
atencioncliente@gardena.es

Suriname

Agrofix n.v.
Verlengde Hogestraat # 22
Phone: (+597) 472426
agrofix@sr.net
Pobox : 2006
Paramaribo
Suriname – South America

Sweden

Husqvarna AB
Gardena Division
S-561 82 Huskvarna
info@gardena.se

Switzerland / Schweiz

Husqvarna Schweiz AG
Consumer Products
Industriestrasse 10
5506 Mägenwil
Phone: (+41) (0) 62 887 37 90
info@gardena.ch

Turkey

Dost Bağcı Dış Ticaret
Müesseslik A.Ş
Yunus Mah. Adil Sok. No:3
İc Kapı No: 1 Kartal
34873 İstanbul
Phone: (+90) 216 38 93 939
info@dosbağcı.com.tr

Ukraine / Україна

ТОВ „Хускварна Україна“
вул. Васильківська, 34,
офіс 204-г
03022, Київ
Тел. (+38) 044 498 39 02
info@gardena.ua

Uruguay

FELI SA
Entre Ríos 1083 CP 11800
Montevideo – Uruguay
Tel: (+598) 22 03 18 44
info@felisa.com.uy

Venezuela

Corporación Casa y Jardín C.A.
Av. Caroní, Edif. Trezmen, PB.
Colinas de Bello Monte,
1050 Caracas.
Tlf: (+58) 212 992 33 22
info@casayjardin.net.ve

4066-20.960.06/0117
© GARDENA Manufacturing GmbH
D-89070 Ulm
http://www.gardena.com