

9000  
aquasensor  
Art. 1783

13000  
aquasensor  
Art. 1785

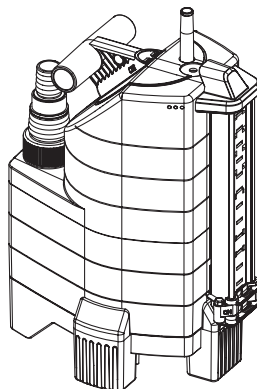

8500  
aquasensor  
Art. 1797

13000  
aquasensor  
Art. 1799

- DE Betriebsanleitung**  
Tauchpumpe/Schmutzwasserpumpe
- 
- EN Operator's Manual**  
Submersible Pump/Dirty Water Pump
- 
- FR Mode d'emploi**  
Pompe d'évacuation pour eaux claires/  
Pompe d'évacuation pour eaux chargées
- 
- NL Gebruiksaanwijzing**  
Dompelpomp/Vuilwaterpomp
- 
- SV Bruksanvisning**  
Dränkbar pump/Spillvattenpump
- 
- DA Brugsanvisning**  
Dykpumpe /Dykpumpe til urent vand
- 
- FI Käyttöohje**  
Upporumpu/liikavesipumppu
- 
- NO Bruksanvisning**  
Lensepumpe/Lensepumpe for urent vann
- 
- IT Istruzioni per l'uso**  
Pompa sommersa/  
Pompa sommersa per acqua sporca
- 
- ES Instrucciones de empleo**  
Bomba sumergible/  
Bomba para aguas sucias
- 
- PT Manual de instruções**  
Bomba submersível/  
Bomba para águas sujas
- 
- PL Instrukcja obsługi**  
Pompa zanurzeniowa/  
Pompa do brudnej wody
- 
- HU Használati utasítás**  
Merülőszivattyú/Szennyvízszivattyú
- 
- CS Návod k obsluze**  
Ponorné čerpadlo/kalové čerpadlo

- SK Návod na obsluhu**  
Ponorné čerpadlo/kalové čerpadlo
- 
- EL Οδηγίες χρήσης**  
Βυθιζόμενη αντλία/Αντλία Ακαθάρτων
- 
- RU Инструкция по эксплуатации**  
Погружной насос/  
Насос для грязной воды
- 
- SL Navodilo za uporabo**  
Potopna črpalka/  
črpalka za umazano vodo
- 
- HR Upute za uporabu**  
Potopna crpka/crpka za otpadnu vodu
- 
- SR/ Uputstvo za rad**  
**BS** Potopna pumpa/Pumpa za prljavu vodu
- 
- UK Інструкція з експлуатації**  
Заглибний насос/  
насос для брудної води
- 
- RO Instrucțiuni de utilizare**  
Pompa submersibilă/  
Pompă de apă murdară
- 
- TR Kullanma Kılavuzu**  
Dalgiç Pompa/Kirli Su Pompası
- 
- BG Инструкция за експлоатация**  
Потопяема дренажна помпа/  
Помпа за мръсна вода
- 
- SQ Manual përdorimi**  
Pompë zhytëse/Pompë për ujë të pisët
- 
- ET Kasutusjuhend**  
Uputatav pump/Reoveepump
- 
- LT Eksploatavimo instrukcija**  
Panardinamas siurblys/  
Purvino vandens siurblys
- 
- LV Lietošanas instrukcija**  
Iegremdējamais sūknis/  
Netīrā ūdens sūknis

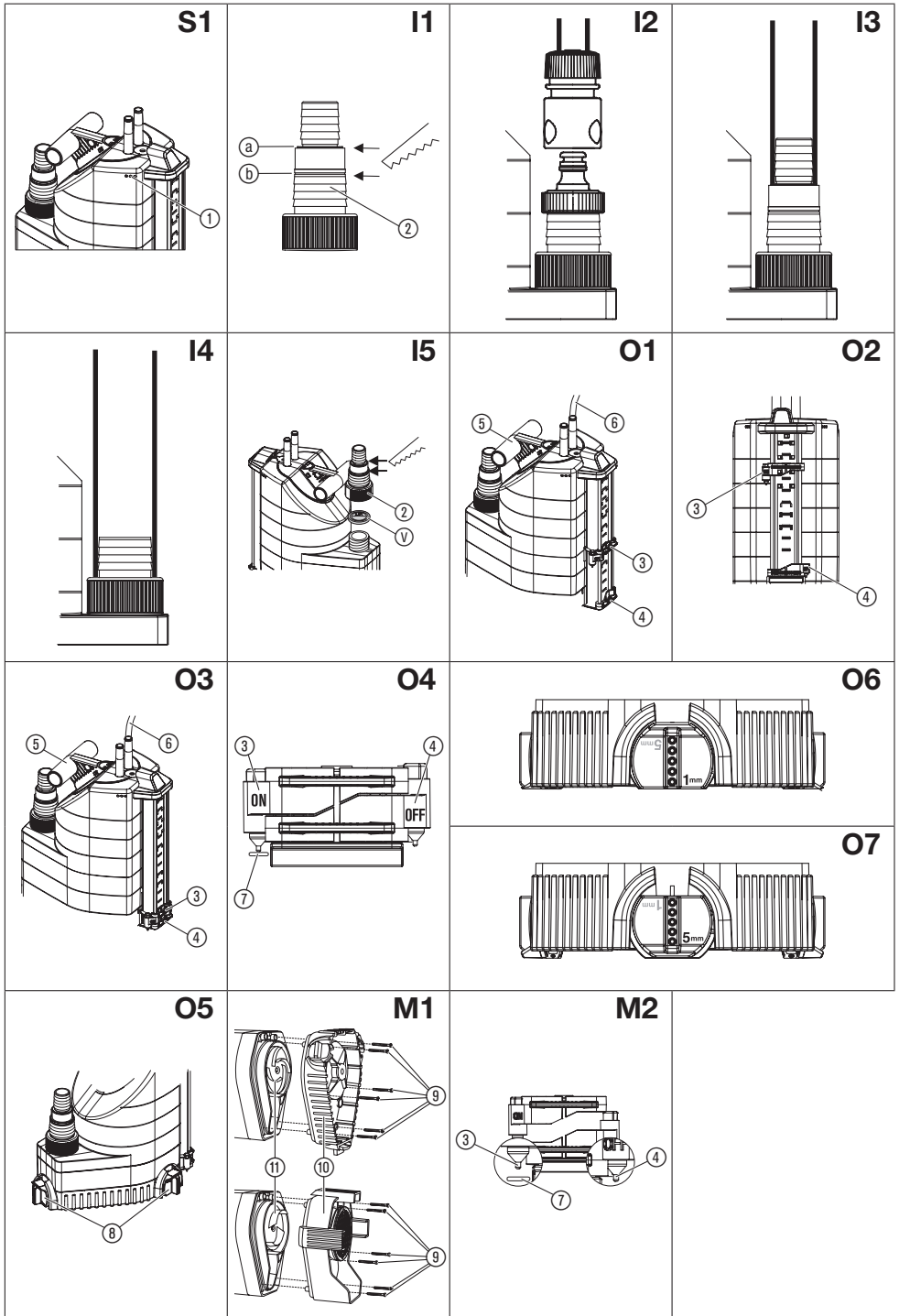

# GARDENA

## Submersible Pump 9000 / 13000 aquasensor / Dirty Water Pump 8500 / 13000 aquasensor

1. SAFETY .....	10
2. INITIAL OPERATION .....	11
3. OPERATION .....	12
4. STORAGE .....	13
5. MAINTENANCE .....	13
6. TROUBLESHOOTING .....	13
7. TECHNICAL DATA .....	14
8. SERVICE / WARRANTY .....	15

### Original instructions.



This product may be used under supervision, or if instruction regarding the safe use of the product has been provided and the resulting dangers have been understood, by children aged 8 and above, as well as by persons with physical, sensory or mental disabilities or a lack of experience and knowledge. Children must not be allowed to play with the product. Cleaning and user maintenance must not be performed by children without supervision. The use of this product by young people under the age of 16 is not recommended. Never

operate the product when you are tired, ill or under the influence of alcohol, drugs or medicine.

### Intended use:

GARDENA Pumps have been designed for private use around your house and garden. They are predominantly destined for drainage after flooding, transfer of liquids, draining containers, taking water from wells and shafts, draining boats and yachts as well as for water aeration and circulation for a limited period of time.

### Liquids to be pumped:

Liquids which can be handled by the GARDENA Pump are the following: clean and contaminated water (max. particle size submersible pumps = 5 mm / dirty water pumps = 30 mm) and chlorinated water (prerequisite is the recommended dosage of additives). Dirty water with solid particles such as sand or stones leads to wear of the turbine and of the pump base.

The pumps are fully submersible (waterproof sealed) and can be immersed in the liquid down to a depth of 7 m.

**CAUTION! The GARDENA Pumps are not designed for continuous operation (e.g. continuous circulating operation) in a pond. Your pump's life will be shortened correspondingly by such operation.**

**Corrosive, easily combustible or explosive substances (e.g. gasoline, petroleum, nitro thinner), fats, oils, salt-water and waste water of toilets and urinals must not be pumped. The temperature of the liquid handled should not exceed 35 °C.**

## 1. SAFETY

### IMPORTANT!

Read the operator's manual carefully before use and keep for future reference.

### Electrical safety



#### DANGER!

**Risk of injury due to electric shock.**

The product must be supplied through a residual current device (RCD) having a rated residual operating current not exceeding 30 mA.

The pump must not be used when people are in water.

→ Please contact your electrician.

According to DIN VDE (German Electrical Engineers' Association) 0620, mains power cables must not have a smaller cross-section than the rubber-sheathed cables of the designation H05RN-F (for Art. Nos. 1783/1797) or H07RN-F (for Art. Nos. 1785/1799). The cable length must be at least 10 m.

Data indicated on the type plate must match technical data of the mains supply.

→ Take care that the electrical connections are made within dry area, protected from flooding.

→ Keep mains plug dry.

Protect plug and power cable from heat, oil and sharp edges.



#### DANGER! Electric shock!

With a cut off mains plug, moisture can get into electrical parts via the mains cable and cause a short circuit.

→ **Never cut the mains plug off (e.g. to feed through wall).**

→ Don't use the power cable for plugging off.

→ If the supply cord is damaged, it must be replaced by the manufacturer, its service agent or similarly qualified persons in order to avoid a hazard.

The power cable or the float switch must not be used for mounting or relocating the pump. For submerging or lifting/securing the pump, fix a rope to the pump's carrying handle.

Extension cables must meet the requirements of DIN VDE 0620.

### In Austria

In Austria the electrical connection must satisfy the ÖVE-EM 42, T2 (2000)/1979 § 22 to § 2022.1.

This requires that pumps used for swimming pools and garden ponds may only be powered through an isolating transformer.

→ Please ask your electrician for his advice.

### In Switzerland

In Switzerland mobile appliances which are used outdoors, must be connected via a residual-current device.

### Visual check

→ Before operating the pump, first make a visual check, if there is any damage of the pump (esp. regarding power cable and plug).

→ Observe the minimum water level and the max. delivery height (see 7. TECHNICAL DATA).



**DANGER! Electric shock!**

**A damaged pump must not be used.**

→ In case of damage, please have the pump checked by our GARDENA Service Centre.

### Manual operation

During manual operation, the pump must be switched off as soon as all the liquid has been pumped away.

→ Observe the pump at all times during manual operation.

### Notes on use

Dry-running operation causes increased wear and is to be avoided. Therefore, in manual operation the pump must be immediately unplugged when water fails to flow.

Avoid running of the pump for more than 10 min. against closed delivery side of the pump.

Sand and other abrasive substances cause increased wear and reduce the pump's output.

Take care that the pump is located where the inlet openings at the suction base are obstructed neither completely nor partly.

Stand the pump on a brick if using in a pond.

Leaking lubricants can contaminate the pumped liquid.

### Instructions for submersible pumps

**When you purchase your pump** the swivel feet are set to the **flat suction position** (1 mm).

→ For normal operation, turn the feet 180° to 5 mm.

*The pump is lifted 5 mm.*

→ Clear the outlet line before use.

### Thermal protection switch

The pump is automatically switched off on overheating by the built-in thermal motor protector. After having cooled down, the motor automatically switches on again (see 6. TROUBLESHOOTING).

### Automatic deaerating valve [Fig. S1]:

The automatic deaerating valve eliminates any air pockets in the pump.

If the pump is half submersed, water may come out of the ventilation holes ①.

This is not a defect of your pump, but serves to deaerate the pump.

### DANGER!

This product makes an electromagnetic field while it operates. This field may under some conditions interfere with active or passive medical implants. To decrease the risk of conditions that can possibly injure or kill, we recommend persons with medical implants to speak with their physician and the medical implant manufacturer before you operate the product.

### DANGER!

Small parts can be easily swallowed. There is also a risk that the polybag can suffocate toddlers. Keep toddlers away when you assemble the product.

## 2. INITIAL OPERATION

<b>Hose diameter</b>	13 mm (½") 16 mm (⅝") 19 mm (¾")	25 mm (1")	38 mm (1 ½")
<b>Hose connection of universal fitting</b> ② [Fig. I1]	[Fig. I2]	[Fig. I3]	[Fig. I4]
<b>Hose connection</b>	Cut off topmost nipple at ③.	Do not cut off any nipples.	Cut off top two nipples at ④.

The following connection kits are required for 13 mm to 19 mm connections:

13 mm (1/2"): GARDENA Pump Connection Set	Art. 1750
16 mm (5/8"): GARDENA Tap Connector GARDENA Standard Hose Connector	Art. 18202 and Art. 18216
19 mm (3/4"): GARDENA Pump Connection Set	Art. 1752

Best results in delivery capacity are achieved when using 38 mm (1 1/2") hoses.

#### Connecting the hose [Fig. I5]:

The universal fitting ② allows you to connect all the hoses listed in the previous table.

1. Cut off nipples of the universal fitting ②, which are not needed, or match the hose connection.
2. **Only for the submersible pumps Art. 1783/1785:** Insert the non-return valve ⑤ supplied into the universal connector 2 with the word UP pointing upwards.

3. Screw the universal fitting ② onto the pump.
4. Connect the hose to the universal fitting ②.

We recommend 38 mm (1 1/2") 25 mm (1") hoses, in addition to be fixed with a **GARDENA Hose Clamps Art. 7192** (for 25 mm) and **Art. 7193** (for 38 mm).

#### Only for the submersible pumps Art. 1783/1785:

For flat suction we recommend using a 13 mm (1/2") or 16 mm (5/8") hose. The non-return valve ⑤ prevents the water flowing back through the hose. The max. delivery height will only be achieved without the non-return valve.

#### Only for 13 mm (1/2") hose:

The universal fitting ② can also be equipped with a **GARDENA Regulator Valve Art. 977** so that the contents of the outlet line do not flow back through the pump after pumping. The Regulator Valve can be ordered from your GARDENA dealer.

## 3. OPERATION

#### Automatic operation [Fig. O1]:

If the water level reaches the **ON** sensor 3, the pump automatically switches on. Depending on water volume and environment, it can take 1 to 3 minutes until pumping out commences.

#### Immediate delivery is possible given the following switch-on level of the ON sensor:

- from 5 mm for Art. 1783/1785 without non-return valve
- from 30 mm for Art. 1783/1785 with non-return valve
- from 95 mm for Art. 1797/1799

As soon as the water level falls below the **OFF** sensor ④, the pump is automatically switched off (the pump continues to run for approx. 10 seconds).

1. Stand the pump on a firm surface  
– or –  
use a rope attached through the bore hole in the carrying handle 5 to immerse the pump in a well or shaft.
2. Plug the power cable 6 into a mains socket.

#### Adjust switch-on and switch-off height [Fig. O2]:

The switch-on and switch-off height (see 7. TECHNICAL DATA) can be adjusted for automatic mode. The relevant sensor pin defines the height of the water level.

#### Set switch-on height ON:

- Push **ON** sensor ③ to the required switch-on height.  
*Switch-on height of the pump in automatic mode.*

#### Set switch-off height OFF:

- Push **OFF** sensor ④ to the required switch-off height.  
*Switch-off height of the pump in automatic mode.*

#### Manual operation [Fig. O3/O4]:

The pump remains in operation continuously. The **ON** sensor ③ is locked in manual position and bridged via the contact ⑦.

1. Push **OFF** sensor ④ and **ON** sensor ③ right down so that the **ON** sensor ③ touches the contact ⑦.
2. Stand the pump on a firm surface  
– or –  
use a rope attached through the bore hole in the carrying handle ⑤ to immerse the pump in a well or shaft.
3. Plug the power cable ⑥ into a mains socket.

#### Only for the submersible pumps: Flat suction/Normal operation [Fig. O5]:

##### Flat suction [Fig. O6]:

- Turn the 3 swivel feet ⑧ 180° to 1 mm.

##### Normal operation [Fig. O7]:

- Turn the 3 swivel feet ⑧ 180° to 5 mm.

The residual water level of approx. 1 mm is only reached during flat suction in the manual operation mode.

## 4. STORAGE

### To put into storage:

→ Store the pump away from frost before the first frost sets in.

### Disposal:

(in accordance with RL2012/19/EC)

The product must not be disposed of to normal household waste. It must be disposed of in line with local environmental regulations.



### IMPORTANT!

Dispose of the product through or via your municipal recycling collection centre.

## 5. MAINTENANCE

The pumps are virtually maintenance-free.

### Flushing the Pump:

After having pumped chlorinated swimming pool water or other liquids leaving residues, the pump should be rinsed with clear water.

### Cleaning the suction base and impeller [Fig. M1]:



**DANGER! Electric shock!**

**Risk of injury due to electric shock.**

→ Disconnect the pump from the mains before cleaning the suction base and impeller.

1. Unscrew the 6 Phillips screws ⑨ and pull the suction base ⑩ off the pump.

- Clean suction base ⑩ and impeller ⑪ (the warranty does not become void as a result of this maintenance work).
- Reinstall the suction base ⑩ and screw in the Phillips screws ⑨.

**For safety reasons a damaged impeller ⑪ can only be exchanged by the GARDENA Service Centre.**

### Clean sensors [Fig. M2]:

**The sensors will only work reliably if they are cleaned regularly (at least every 2 months)!**

→ Clean the sensors ③/④ and contact ⑦ regularly with a dry cloth (do not use hard or sharp objects).

## 6. TROUBLESHOOTING

Problem	Possible Cause	Remedy
<b>Pump is running, but doesn't deliver</b>	Air cannot escape.	→ Open pressure line (e.g. kinked pressure pipe). → Remove the non-return valve.
	Non-return valve inserted wrongly.	→ Insert the non-return valve with the word UP on top.
	Air locks in the suction base.	→ Wait for max. 60 seconds until the pump deaerates automatically over the vent valve. If necessary, switch off and start it again.
	Impeller clogged.	→ Disconnect plug and clean impeller (see 5. MAINTENANCE).
	When starting the pump, water height falls below the min. water level.	→ Submerge pump deeper.
<b>The pump does not switch on or off. Pump switches off although the OFF sensor is in the water</b>	Sensors ③/④ and contacts ⑦ are dirty.	→ Clean sensors (see 5. MAINTENANCE).
<b>Pump doesn't start or suddenly stops during operation</b>	Thermal overload switch has switched the pump off due to overheating.	→ Disconnect plug and clean impeller (see 5. MAINTENANCE). Observe max. media temperature of 35 °C.
	No power.	→ Check fuses and electric connections.

Problem	Possible Cause	Remedy
<b>Pump doesn't start or suddenly stops during operation</b>	Dirt particles are jammed in the suction base.	→ Disconnect plug and clean suction base (see 5. MAINTENANCE).
<b>Pump runs, but output suddenly decreases</b>	Suction base is clogged.	→ Disconnect plug and clean suction base (see 5. MAINTENANCE).



**NOTE:** For any other malfunctions please contact the GARDENA service department. Repairs must only be done by GARDENA service departments or specialist dealers approved by GARDENA.

## 7. TECHNICAL DATA

	Unit	Submersible pumps aquasensor		Dirty water pumps aquasensor	
		Value 9000 (Art. 1783)	Value 13000 (Art. 1785)	Value 8500 (Art. 1797)	Value 13000 (Art. 1799)
<b>Rated Power</b>	W	320	650	380	680
<b>Rated power</b>	l/h	9,000	13,000	8,300	13,000
<b>Max. delivery capacity</b>	bar	0.7	0.8	0.6	0.9
<b>Max. pressure</b>	m	7	8	6	9
<b>Max. delivery height</b>	m	7	7	7	7
<b>Max. submersion depth</b>	mm	1	1	35	35
<b>Contaminated water with particle size of max.</b>	mm	5	5	30	30
<b>Power cable</b>	m	10 H05RN-F	10 H07RN-F	10 H05RN-F	10 H07RN-F
<b>Pump connection</b>		universal (G 1 ¼" M) / universal nipple			
<b>Min. water level for operation</b>	mm	5	5	45	45
<b>Weight approx. (without cable)</b>	kg	3.8	5.4	4.0	5.6
<b>Max. media temperature</b>	°C	35	35	35	35
<b>Mains voltage/Mains frequency</b>	V / Hz	230 / 50	230 / 50	230 / 50	230 / 50
<b>Min./max. cut-in height</b>	mm	5 / 175	5 / 210	65 / 230	70 / 265
<b>Min./max. cut-out height</b>	mm	3 / 170	3 / 205	40 / 225	40 / 260
<b>Sound power level <math>L_{WA}</math><sup>1)</sup></b>	dB (A)	48	55	55	55

Measuring process complying with: <sup>1)</sup> EN 60335-1

### **Cut-in/Cut-out height:**

The cut-in and cut-out height varies.

### **Only for the submersible pumps Art. 1783/1785:**

The residual water height (flat suction down to approx. 1 mm) is only reached during manual operation with the swivel feet ⑥ turned to 1 mm (see 3. OPERATION).

## 8. SERVICE / WARRANTY

---

### **Service:**

Please contact the address on the back page.

### **Warranty:**

In the event of a warranty claim, no charge is levied to you for the services provided.

GARDENA Manufacturing GmbH offers a two-year warranty (effective as of the date of purchase) for this product.

This warranty includes all significant defects of the product that can be proved to be material or manufacturing faults.

This warranty is fulfilled by supplying a fully functional replacement product or by repairing the faulty product sent to us free of charge; we reserve the right to choose between these options. This service is subject to the following provisions:

- The product was used for its intended purpose as per the recommendations in the operating instructions.

- Neither the purchaser nor a third party has attempted to repair the product.

This manufacturer's warranty does not affect warranty entitlements against the dealer/retailer.

If problems arise with this product, please contact our Service department or send the defective product along with a brief description of the fault to GARDENA Manufacturing GmbH, making sure to have sufficiently covered any shipping costs and to have followed the relevant postage and packaging guidelines. A warranty claim must be accompanied by a copy of the proof of purchase.

### **Consumables:**

The wear parts turbine and pump base are excluded from the guarantee.



**Pumpen-Kennlinien**

*Performance characteristics*

*Courbes de performance*

*Prestatiegrafiek*

*Kapacitetskurva*

*Ydelses karakteristika*

*Pumpun ominaiskäyrä*

*Pumpekarakteristikk*

*Curva di rendimento*

*Curva característica de la bomba*

*Características de performance*

*Charakterystyka pompy*

*Szivattyú-jelleggörbe*

*Charakteristika čerpadla*

*Charakteristiky čerpadla*

*Χαράκτηριστικό διάγραμμα*

*Характеристика насоса*

*Karakteristika črpalke*

*Obilježja pumpe*

*Karakteristika pumpe*

*Крива характеристики насоса*

*Caracteristică pompă*

*Pompa karakter eğrisi*

*Помпена характеристика*

*Fuqia e pompës*

*Pumba karakteristik*

*Siurblio charakteristinė kreivė*

*Σύγκρα raksturlīkne*

**7000 Art. 1783/1785**

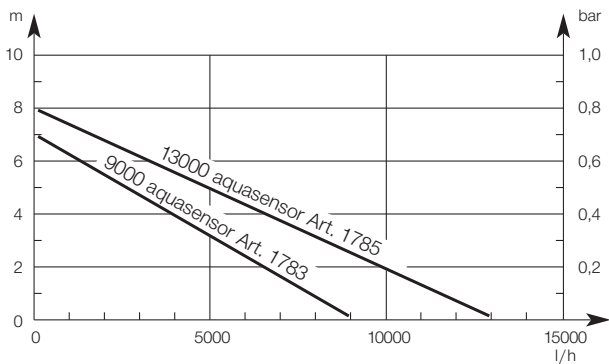

**7500 Art. 1797/1799**

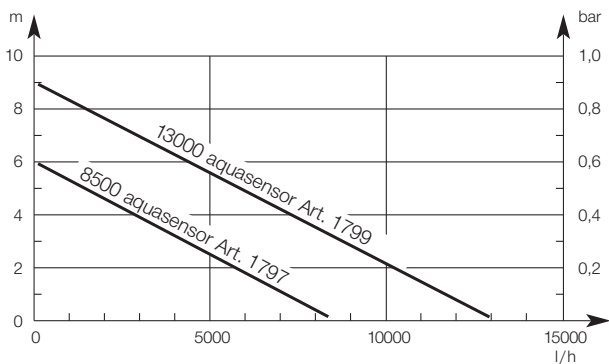

## **DE Produkthaftung**

Wir weisen ausdrücklich darauf hin, dass wir in Übereinstimmung mit dem Produkthaftungsgesetz nicht für Schäden haften, die durch unsere Produkte entstehen, wenn diese unsachgemäß und nicht durch einen von uns autorisierten Servicepartner repariert wurden oder wenn keine Original GARDENA Teile oder von uns zugelassene Teile verwendet wurden.

## **EN Product liability**

In accordance with the German Product Liability Act, we hereby expressly declare that we accept no liability for damage incurred from our products where said products have not been properly repaired by a GARDENA-approved service partner or where original GARDENA parts or parts authorised by GARDENA were not used.

## **FR Responsabilité**

Conformément à la loi relative à la responsabilité du fait des produits défectueux, nous déclarons expressément par la présente que nous déclinons toute responsabilité pour les dommages résultant de nos produits, si lesdits produits n'ont pas été correctement réparés par un partenaire d'entretien agréé GARDENA ou si des pièces d'origine GARDENA ou des pièces agréées GARDENA n'ont pas été utilisées.

## **NL Productaansprakelijkheid**

Conform de Duitse wet inzake productaansprakelijkheid verklaren wij hierbij uitdrukkelijk dat wij geen aansprakelijkheid aanvaarden voor schade ontstaan uit onze producten waarbij deze producten niet zijn gerepareerd door een GARDENA-erkende servicepartner of waarbij geen originele GARDENA-onderdelen of onderdelen die door GARDENA zijn goedgekeurd zijn gebruikt.

## **SV Produktsvar**

I enlighet med tyska produktansvarslagar förklarar vi härmed uttryckligen att vi inte åtar oss något ansvar för skador som orsakas av våra produkter där produkterna inte har genomgått korrekt reparation från en GARDENA-godkänd servicepartner eller där originaldelar från GARDENA eller delar godkända av GARDENA inte använts.

## **DA Produktsvar**

I overensstemmelse med den tyske produktansvarslov erklærer vi hermed udtrykkeligt, at vi ikke påtager os noget ansvar for skader på vores produkter, hvis de pågældende produkter ikke er blevet repareret korrekt af en GARDENA-godkendt servicepartner, eller hvor der ikke er brugt originale GARDENA-reservedele eller godkendte reservedele fra GARDENA.

## **FI Tuotevastuu**

Saksan tuotevastuulain mukaisesti emme ole vastuussa laitteiden vaurioista, jos korjauksia ei ole tehnyt GARDENAn hyväksymä huoltoliike tai jos niiden syynä on muiden kuin alkuperäisten GARDENA-varaosien tai GARDENAn hyväksymien varaosien käyttö.

## **IT Responsabilità del prodotto**

In conformità con la Legge tedesca sulla responsabilità del prodotto, con la presente dichiariamo espressamente che decliniamo qualsiasi responsabilità per danni causati dai nostri prodotti qualora non siano stati correttamente riparati presso un partner di assistenza approvato GARDENA o laddove non siano stati utilizzati ricambi originali o autorizzati GARDENA.

## **ES Responsabilidad sobre el producto**

De acuerdo con la Ley de responsabilidad sobre productos alemana, por la presente declaramos expresamente que no aceptamos ningún tipo de responsabilidad por los daños ocasionados por nuestros productos si dichos productos no han sido reparados por un socio de mantenimiento aprobado por GARDENA o si no se han utilizado piezas originales GARDENA o piezas autorizadas por GARDENA.

## **PT Responsabilidade pelo produto**

De acordo com a lei alemã de responsabilidade pelo produto, declaramos que não nos responsabilizamos por danos causados pelos nossos produtos, caso os tais produtos não tenham sido devidamente reparados por um parceiro de assistência GARDENA aprovado ou se não tiverem sido utilizadas peças GARDENA originais ou peças autorizadas pela GARDENA.

## **PL Odpowiedzialność za produkt**

Zgodnie z niemiecką ustawą o odpowiedzialności za produkt, niniejszym wyraźnie oświadczamy, że nie ponosimy żadnej odpowiedzialności za szkody poniesione na skutek użytkowania naszych produktów, w przypadku gdy naprawa tych produktów nie była odpowiednio przeprowadzana przez zatwierdzonego przez firmę GARDENA partnera serwisowego lub nie stosowano oryginalnych części GARDENA albo części autoryzowanych przez tę firmę.

## **HU Termékszavatosság**

A németországi termékszavatossági törvénnyel összhangban ezzel nyomatékosan kijelentjük, hogy nem vállalunk felelősséget a termékeinkben keletkezett olyan károkért, amelyek valamely GARDENA által jóváhagyott szervizpartner által nem megfelelően végzett javításból adódtak, vagy amely során nem eredeti GARDENA alkatrészeket vagy a GARDENA által jóváhagyott alkatrészeket használtak fel.

## **CS Odpovědnost za výrobek**

V souladu s německým zákonem o odpovědnosti za výrobek tímto výslovně prohlašujeme, že nepřijímáme žádnou odpovědnost za poškození vzniklá na našich výrobcích, kdy zmíněné výrobky nebyly řádně opraveny schváleným servisním partnerem GARDENA nebo kdy nebyly použity originální náhradní díly GARDENA nebo náhradní díly autorizované společností GARDENA.

## **SK Zodpovednosť za produkt**

V súlade s nemeckými právnymi predpismi upravujúcimi zodpovednosť za výrobok týmto výslovne prehlasujeme, že nenesieme žiadnu zodpovednosť za škody spôsobené našimi výrobkami, v prípade ktorých neboli náležité opravy vykonané servisným partnerom schváleným spoločnosťou GARDENA alebo neboli použité diely spoločnosti GARDENA alebo diely schválené spoločnosťou GARDENA.

## **EL Ευθύνη προϊόντος**

Σύμφωνα με τον γερμανικό νόμο περί Ευθύνης για τα Προϊόντα, με το παρόν δηλώνουμε ρητώς ότι δεν αποδεχόμαστε καμία ευθύνη για τυχόν ζημιές που προκύπτουν από τα προϊόντα μας εάν αυτά δεν έχουν επισκευαστεί σωστά από κάποιον συγκεκριμένο συνεργάτη επισκευών της GARDENA ή εάν δεν έχουν χρησιμοποιηθεί αυθεντικά εξαρτήματα GARDENA ή εξαρτήματα εγκεκριμένα από την GARDENA.

## **SL Odgovornost proizvajalca**

V skladu z nemškimi zakoni o odgovornosti za izdelke, izrecno izjavljajo, da ne sprejemamo nobene odgovornosti za škodo, ki jo povzročijo naši izdelki, če teh niso ustrezno popravili GARDENINI odobreni servisni partnerji ali pri tem niso bili uporabljeni originalni GARDENINI nadomestni deli ali GARDENINIMI homologiranimi nadomestnimi deli.

## **HR Pouzdanost proizvoda**

Sukladno njemačkom zakonu o pouzdanosti proizvoda, ovime izričito izjavljujemo kako ne prihvaćamo nikakvu odgovornost za oštećenja na našim proizvodima nastala uslijed neispravnog popravka od strane servisnog partnera kojeg odobrava GARDENA ili uslijed nekorištenja originalnih GARDENA dijelova ili dijelova koje odobrava GARDENA.

## **RO Răspunderea pentru produs**

În conformitate cu Legea germană privind răspunderea pentru produs, declarăm în mod expres prin prezentul document că nu acceptăm nicio răspundere pentru defecțiunile suferite de produsele noastre atunci când acestea nu au fost reparate în mod corect de un atelier de service partener, aprobat de GARDENA, sau când nu au fost utilizate piese GARDENA originale sau piese autorizate de GARDENA.

## **BG Отговорност за вреди, причинени от стоки**

Съгласно германския Закон за отговорността за вреди, причинени от стоки, с настоящото изрично декларираме, че не носим отговорност за щети, причинени от нашите продукти, ако те не са били правилно ремонтирани от одобрен от GARDENA сервиз или ако не са използвани оригинални части на GARDENA или части, одобрени от GARDENA.

## **ET Tootevastutus**

Vastavalt Saksamaa tootevastutusseadusele deklareerime käesolevaga selgesõnaliselt, et me ei kannu mingisugust vastutust meie toodetest tingitud kahjude eest, kui need tooted ei ole korrektselt parandatud GARDENA heakskiidetud hoolduspartneri poolt või kui parandamisel ei ole kasutatud GARDENA originaalosi või GARDENA volitatud osi.

## **LT Gaminio patikimumas**

Mes aiškiai pareiškiamo, kad, atsižvelgiant į Vokietijos gaminių patikimumo įstatymą, neprisiimame atsakomybės dėl bet kokios žalos, patirtos dėl mūsų gaminių, jeigu jie buvo netinkamai taisomi arba jų dalys buvo pakeistos neoriginaliomis GARDENA dalimis ar nepatvirtintomis dalimis, arba jeigu remonto darbai buvo atliekami ne GARDENA techninės priežiūros centro specialistų.

## **LV Atbildība par produkcijas kvalitāti**

Saskaņā ar Vācijas likumu par atbildību par produkcijas kvalitāti ar šo mēs paziņojam, ka neuzņemamies atbildību par bojājumiem, kas radušies, lietojot mūsu izstrādājumus, kuru remontu nav veicis uzņēmuma GARDENA apstiprināts apkopes partneris vai kuru remontam netika izmantotas oriģinālās GARDENA detaļas vai detaļas, kuru lietošanu apstiprinājis uzņēmums GARDENA.

<p><b>DE EU-Konformitätserklärung</b></p> <p>Der Unterzeichner, Husqvarna AB, 561 82 Huskvarna, Schweden, bescheinigt hiermit, dass die nachstehend aufgeführten Geräte bei Verlassen des Werks die harmonisierten EU-Leitlinien, EU-Normen für Sicherheit und besondere Normen erfüllen. Dieses Zertifikat verliert seine Gültigkeit, wenn die Geräte ohne unsere Genehmigung verändert werden.</p>	<p><b>HU EK megfeleléségi nyilatkozat</b></p> <p>Alulírott Husqvarna AB, 561 82 Huskvarna, Svédország ezzel tanúsítja, hogy az alábbiakban leírt egységek a gyár elhagyásakor megfelelték a harmonizált uniós előírásoknak és biztonsági és termékspecifikus szabványoknak. Ez a tanúsítvány érvényes veszt, ha az egységeket jóváhagyásunk nélkül átalakítják.</p>
<p><b>EN EC Declaration of Conformity</b></p> <p>The undersigned, Husqvarna AB, 561 82 Huskvarna, Sweden, hereby certifies that, when leaving our factory, the units indicated below are in accordance with the harmonised EU guidelines, EU standards of safety and product specific standards. This certificate becomes void if the units are modified without our approval.</p>	<p><b>CS Prohlášení o shodě ES</b></p> <p>Niže uvedená společnost Husqvarna AB, 561 82 Huskvarna, Švédsko, tímto potvrzuje, že při opuštění naší továrny jsou jednotky uvedené níže v souladu s harmonizačnými pokyny EU, standardy EU ohledně bezpečnosti a specifickými produktovými standardy. Tento certifikát pozbyvá platnosti, pokud dojde k úpravě jednotek bez našeho schválení.</p>
<p><b>FR Déclaration de conformité CE</b></p> <p>Le constructeur, soussigné : Husqvarna AB, 561 82 Huskvarna, Suède, déclare qu'à la sortie de ses usines le matériel neuf désigné ci-dessous était conforme aux prescriptions des directives européennes énoncées ciaprès et conforme aux règles de sécurité et autres règles qui lui sont applicables dans le cadre de l'Union européenne. Toute modification apportée à cet appareil sans notre accord annule la validité de ce certificat.</p>	<p><b>SK EÚ vyhlásenie o zhode</b></p> <p>Dolu podpísaná spoločnosť Husqvarna AB, 561 82 Huskvarna, Švédsko týmto osvedčuje, že nižšie uvedené jednotky boli v súlade s harmonizačnými usmerneniami EÚ, normami EÚ v oblasti bezpečnosti a špecifickými normami týkajúcimi sa produktu v čase opustenia výrobného závodu. Toto osvedčenie stráca platnosť, ak boli jednotky zmenené bez nášho súhlasu.</p>
<p><b>NL EG-conformiteitsverklaring</b></p> <p>De ondergetekende, Husqvarna AB, 561 82 Huskvarna, Zweden, verklaart hierbij dat de producten die hieronder staan vermeld, wanneer ze onze fabriek verlaten, in overeenstemming zijn met de geharmoniseerde Europese richtlijnen, EU-normen voor veiligheid en productspecifieke normen. Dit certificaat vervalt als de producten worden aangepast zonder onze toestemming.</p>	<p><b>EL Δήλωση Συμμόρφωσης EK</b></p> <p>Η υπογεγραμμένη εταιρεία, Husqvarna AB, 561 82 Huskvarna, Σουηδία, πιστοποιεί ότι, κατά την έξοδο από το εργοστάσιο, οι μονάδες που αναφέρονται κατωτέρω συμμορφώνονται με τις εναρμονισμένες οδηγίες ΕΕ, τα πρότυπα ασφαλείας της ΕΕ και τα συγκεκριμένα πρότυπα προϊόντος. Αυτό το πιστοποιητικό καθίσταται άκυρο εάν οι μονάδες έχουν τροποποιηθεί χωρίς την έγκρισή μας.</p>
<p><b>SV EG-försäkran om överensstämmelse</b></p> <p>Undertecknad firma Husqvarna AB, 561 82 Huskvarna, Sverige, intygar härmed att nedan nämnda produkter, när de lämnar vår fabrik, överensstämmer med EU:s riktlinjer, EU:s säkerhetsstandarder och produktspecifika standarder. Detta intyg skall ogiltigförklaras om produkten ändras utan vårt godkännande.</p>	<p><b>SL Izjava ES o skladnosti</b></p> <p>Spodaj podpisana, Husqvarna AB, 561 82 Huskvarna, Švedska, s to izjavo potrjuje, da je bila spodaj navedena enota ob izhodu iz tovarne skladna z usklajalnimi smernicami EU, standardi EU za varnost in standardi, specifičnimi za izdelek. Izjava postane neveljavna v primeru neodobrene spremembe enote.</p>
<p><b>DA EU-overensstemmelseserklæring</b></p> <p>Undertegnede, Husqvarna AB, 561 82 Huskvarna, Sverige erklærer hermed, at nedenfor anførte enheder er i overensstemmelse med de harmoniserede EU-retningslinjer, EU-standarder for sikkerhed og produktspecifikke standarder, når de forlader fabrikken. Denne erklæring ugyldiggøres, hvis enhederne ændres uden vores godkendelse.</p>	<p><b>HR Izjava o uskladenosti EZ</b></p> <p>Niže potpisana Husqvarna AB, 561 82 Huskvarna, Švedska, ovime potvrđuje kako su u nastavku navedene jedinice prilikom napuštanja tvornice bile u skladu s uskladenim smjernicama EU, EU sigurnosnim standardima i standardima specifičnima za proizvod. Ova certifikacija poništava se ako se jedinice izmjenjuju bez odobrenja.</p>
<p><b>FI EY-vaatimustenmukaisuusvakuutus</b></p> <p>Husqvarna AB, 561 82 Huskvarna, Ruotsi, vakuuttaa täten, että alla mainitut laitteet ovat tehtaalta lähtiesään yhdenmukaiset EU-säännösten, EU:n turva-standardien ja tuotekohtaisten standardien mukaisia. Tämä vakuutus mitätöityy, jos laitteita muokataan ilman hyväksyntäämme.</p>	<p><b>RO Declarație de conformitate CE</b></p> <p>Subscrisa, Husqvarna AB, 561 82 Huskvarna, Suedia, certifică prin prezenta că, la momentul ieșirii din fabrica noastră, unitățile indicate mai jos sunt în conformitate cu directivele UE armonizate, cu standardele UE de siguranță și cu standardele specifice ale produsului. Prezentul certificat devine nul dacă unitățile sunt modificate fără aprobarea noastră.</p>
<p><b>IT Dichiarazione di conformità CE</b></p> <p>La sottoscritta Husqvarna AB, 561 82 Huskvarna, Svezia, certifica che il prodotto qui di seguito indicato, nei modelli da noi commercializzati, è conforme alle direttive armonizzate UE nonché agli standard di sicurezza UE e agli standard specifici di prodotto. Qualunque modifica apportata al prodotto senza nostra specifica autorizzazione invalida la presente dichiarazione.</p>	<p><b>BG Декларация за съответствие на ЕО</b></p> <p>С настоящото долуподписаната, Husqvarna AB, 561 82 Huskvarna, Швеция, удостоверява, че при напускане на фабриката модулите, посочени по-долу, са в съответствие с хармонизираните директиви на ЕС, стандартите на ЕС за безопасност и специфичните за продукта стандарти. Този сертификат става невалиден, ако модулите са променени без нашето одобрение.</p>
<p><b>ES Declaración de conformidad CE</b></p> <p>El abajo firmante, Husqvarna AB, 561 82 Huskvarna, Suecia, certifica por la presente que, cuando salen de la fábrica, las unidades indicadas a continuación cumplen las normas de armonización de la UE, las normas de la UE sobre seguridad y las normas específicas del producto. Este certificado quedará sin efecto si se modifican las unidades sin nuestra autorización.</p>	<p><b>ET EÜ vastavusdeklaratsioon</b></p> <p>Allkirjutatu Husqvarna AB, 561 82 Huskvarna, Rootsi, kinnitab käesolevaga, et tehased väljulehit vastavad alpool nimetatud seadmed harmoneeritud EL-i suunistele, EL-i ohutusstandarditele ja tootele eriomastele standarditele. See vastavuskinnitus kaotab kehtivuse, kui seadet muudetakse ilma meie heakskiuduta.</p>
<p><b>PT Declaração de conformidade CE</b></p> <p>O abaixo assinado, Husqvarna AB, 561 82 Huskvarna, Suécia, certifica por este meio que, ao sair da nossa fábrica, as unidades indicadas acima estão em conformidade com as diretivas uniformizadas da UE, os padrões de segurança da UE e os padrões específicos do produto. Este certificado deixa de ser válido se as unidades forem modificadas sem a nossa aprovação.</p>	<p><b>LT EB atitikties deklaracija</b></p> <p>Husqvarna AB, 561 82 Huskvarna, Sweden, garantuoja, kad iš gamyklos siunčiami toliau nurodyti įrenginiai atitinka suderintus EB reikalavimus, EB saugos ir konkretaus gamtinio standartus. Pakeltus gaminius be mūsų patvirtinimo, nautraikiamas šio sertifikato galiojimas.</p>
<p><b>PL Deklaracja zgodności WE</b></p> <p>Niżej podpisany przedstawiciel firmy Husqvarna AB, 561 82 Huskvarna, Szwecja, niniejszym oświadcza, że podane poniżej wyroby opuszczające fabrykę są zgodne ze zharmonizowanymi normami UE oraz z obowiązującymi w UE przepisami bezpieczeństwa i normami dotyczącymi danego produktu. Modyfikacja wyrobów bez naszej zgody powoduje unieważnienie niniejszego certyfikatu.</p>	<p><b>LV EK atbilstības deklarācija</b></p> <p>Uzņēmums Husqvarna AB, 561 82 Huskvarna, Zviedrija, ar parakstu apliecina, ka tālāk minētās vienības, pametot rūpniec, atbilst saskatotajām ES vadlīnijām, ES drošības standartiem un izstrādājuma specifiskajiem standartiem. Šis sertifikāts tiek anulēts, ja šīs vienības tiek modificētas bez mūsu apstiprinājuma.</p>

Produktbezeichnung: <b>Tauchpumpe / Schmutzwasserpumpe</b> Description of the product: <b>Submersible Pump / Dirty Water Pump</b> Désignation du produit : <b>Pompe d'évacuation pour eaux claires / Pompe d'évacuation pour eaux chargées</b>  Beschrijving van het product: <b>Dompelpomp / Vuilwaterpomp</b> Beskrivning av produktén: <b>Dränkbar pump / Spillvattenpump</b> Beskrivelse af produktet: <b>Dykpumpe / Dykpumpe til urent vand</b> Tuotteen kuvaus: <b>Urppopumppu / likavesipumppu</b> Descrizione del prodotto: <b>Pompa sommersa / Pompa sommersa per acqua sporca</b> Descripción del producto: <b>Bomba sumergible / Bomba para aguas sucias</b> Descrição do produto: <b>Bomba submersível / Bomba para águas sujas</b>  Opis produktu: <b>Pompa zanurzeniowa / Pompa do brudnej wody</b>  A termék leírása: <b>Merülőszivattyú / Szennyvízszivattyú</b> Popis výrobku: <b>Ponorné čerpadlo / kalové čerpadlo</b> Popis produktu: <b>Ponorné čerpadlo / kalové čerpadlo</b> Περιγραφή του προϊόντος: <b>Βυθίζομενη αντλία / Αντλία Ακαθάρτων</b> Opis izdelka: <b>Potopna črpalka / črpalka za umazano vodo</b> Opis proizvoda: <b>Potopna crpka / crpka za otpadnu vodu</b> Descrierea produsului: <b>Pompa submersibilă / Pompă de apă murdară</b> Описание на продукта: <b>Потопна дренажна помпа / Помпа за мръсна вода</b>  Toote kirjeldus: <b>Uputatav pump / Reoveepump</b> Gaminio aprašas: <b>Panardinamas siurblys / Purvino vandens siurblys</b>  Izstrādājuma apraksts: <b>Iegremdējamais sūknis / Netīrā ūdens sūknis</b>		Hinterlegte Dokumentation: GARDENA Technische Dokumentation, M. Kugler 89079 Ulm  Deposited Documentation: GARDENA Technical Documentation, M. Kugler 89079 Ulm  Documentation déposée: Documentation technique GARDENA, M. Kugler 89079 Ulm  Anbringungsjaar der CE-Kennzeichnung: Year of CE marking: Année d'apposition du marquage CE : Installatiejaar van de CE-aanduiding: Märkningsår: CE-Mærkningsår: CE-merkin kiinnitysvuosi: Anno di applicazione della certificazione CE: Colocación del distintivo CE: Ano de marcação pela CE: Rok nadania oznakowania CE: CE-jelzés elhelyezésének éve: Rok umístění značky CE: Rok udelenia značky CE: Έτος σήμανσης CE: Leto namesitve CE-oznake: Godina dobivanja CE oznake: Anul de marcare CE: Година на поставяне на CE-маркировка: CE-märgistuse paigaldamise aasta: Metai, kada pažymėta CE-ženku: CE-märkjējuma uzlikšanas gads:	
Produkttyp: Terméktípus: Product type: Druh výrobku: Type de produit : Typ produktu: Producttype: Τύπος προϊόντος: Produkttyp: Vrsta izdelka: Produkttype: Vrsta proizvoda: Tuotetyyppi: Тип продукт: Tipo di prodotto: Toote tüüp: Tipo de produto: Gaminio tipas: Typ produktu: Produkta veids:		Artikelnummer: Cikkszámok: Article number: Objednací číslo: Référence : Objednávacie číslo: Artikelnummer: Κωδικός είδους: Artikelnummer: Številka izdelka: Artikelnummer: Kataloški broj: Tuotenumero: Cod articol: Codice articolo: Артикъл номер: Referencia: Artiklinumber: Número de Dalies numeris: referència: Artikula numurs: Numer katalogowy:	
<b>aquasensor 9000</b> <b>aquasensor 13000</b> <b>aquasensor 8500</b> <b>aquasensor 13000</b>		<b>1783</b> <b>1785</b> <b>1797</b> <b>1799</b>	
EU-Richtlinien: EC-Directives: Directives CE : EG-richtlijnen: EU-direktiv: EF-direktiver: EY-direktiv: Directive UE: Directiva CE: Diretivas CE: Dyrektywy WE: EK-irányelvek: Předpisy ES: Smernice EÚ: Общиакт, EK: Direktive EU: EC direktive:		Directive CE: Директиви на EO: EU direktivod: EB direktivos: EK direktivas:  <b>2011/65/EC</b> <b>2014/35/EC</b> <b>2014/30/EC</b>	
Harmonisierte EN-Normen / Harmonised EN:		<b>EN ISO 12100</b> <b>EN 60335-1</b> <b>EN 60335-2-41</b>	
		 <b>Reinhard Pompe</b> Vice President	

