

Art. 19080

- DE Betriebsanleitung**
smart Haus- & Gartenautomat
-
- EN Operator's manual**
smart Automatic Home & Garden Pump
-
- FR Mode d'emploi**
Automate smart pour la maison et le jardin
-
- NL Gebruiksaanwijzing**
smart elektronische hydrofoorpomp
-
- SV Bruksanvisning**
smart pumpautomat för hem och trädgård
-
- DA Brugsanvisning**
smart hus- & haveautomat
-
- FI Käyttöohje**
Älykäs smart paine- ja puutarhapumppu
-
- NO Bruksanvisning**
smart hus- og hageautomat

- IT Istruzioni per l'uso**
smart Pompa automatica per uso domestico e giardino
-
- ES Instrucciones de empleo**
Estación de bombeo para casa y jardín smart
-
- PL Instrukcja obsługi**
smart hydrofor elektroniczny
-
- HU Használati utasítás**
smart háztartási- és kerti automata szivattyú
-
- CS Návod k obsluze**
smart domácí a zahradní automat
-
- SK Návod na obsluhu**
smart domácí a záhradný automat
-
- EL Οδηγίες χρήσης**
Πιεστική αντλία νερού οικιακής χρήσης & κήπου smart

DE Produkthaftung

Wir weisen ausdrücklich darauf hin, dass wir in Übereinstimmung mit dem Produkthaftungsgesetz nicht für Schäden haften, die durch unsere Produkte entstehen, wenn diese unsachgemäß und nicht durch einen von uns autorisierten Servicepartner repariert wurden oder wenn keine Original GARDENA Teile oder von uns zugelassene Teile verwendet wurden.

EN Product liability

In accordance with the German Product Liability Act, we hereby expressly declare that we accept no liability for damage incurred from our products where said products have not been properly repaired by a GARDENA-approved service partner or where original GARDENA parts or parts authorised by GARDENA were not used.

FR Responsabilité

Conformément à la loi relative à la responsabilité du fait des produits défectueux, nous déclarons expressément par la présente que nous déclinons toute responsabilité pour les dommages résultant de nos produits, si lesdits produits n'ont pas été correctement réparés par un partenaire d'entretien agréé GARDENA ou si des pièces d'origine GARDENA ou des pièces agréées GARDENA n'ont pas été utilisées.

NL Productaansprakelijkheid

Conform de Duitse wet inzake productaansprakelijkheid verklaren wij hierbij uitdrukkelijk dat wij geen aansprakelijkheid aanvaarden voor schade ontstaan uit onze producten waarbij deze producten niet zijn gerepareerd door een GARDENA-erkende servicepartner of waarbij geen originele GARDENA-onderdelen of onderdelen die door GARDENA zijn goedgekeurd zijn gebruikt.

SV Produktansvar

I enlighet med tyska produktansvarslagar förklarar vi härmed uttryckligen att vi inte åtar oss något ansvar för skador som orsakas av våra produkter där produkterna inte har genomgått korrekt reparation från en GARDENA-godkänd servicepartner eller där originaldelar från GARDENA eller delar godkända av GARDENA inte använts.

DA Produktansvar

I overensstemmelse med den tyske produktansvarslov erklærer vi hermed udtrykkeligt, at vi ikke påtager os noget ansvar for skader på vores produkter, hvis de pågældende produkter ikke er blevet repareret korrekt af en GARDENA-godkendt servicepartner, eller hvor der ikke er brugt originale GARDENA-reservedele eller godkendte reservedele fra GARDENA.

FI Tuotevastuu

Saksan tuotevastuulain mukaisesti emme ole vastuussa laitteiden vaurioista, jos korjauksia ei ole tehnyt GARDENAn hyväksymä huoltoliike tai jos niiden syynä on muiden kuin alkuperäisten GARDENA-varaosien tai GARDENAn hyväksymien varaosien käyttö.

IT Responsabilità del prodotto

In conformità con la Legge tedesca sulla responsabilità del prodotto, con la presente dichiariamo espressamente che decliniamo qualsiasi responsabilità per danni causati dai nostri prodotti qualora non siano stati correttamente riparati presso un partner di assistenza approvato GARDENA o laddove non siano stati utilizzati ricambi originali o autorizzati GARDENA.

ES Responsabilidad sobre el producto

De acuerdo con la Ley de responsabilidad sobre productos alemana, por la presente declaramos expresamente que no aceptamos ningún tipo de responsabilidad por los daños ocasionados por nuestros productos si dichos productos no han sido reparados por un socio de mantenimiento aprobado por GARDENA o si no se han utilizado piezas originales GARDENA o piezas autorizadas por GARDENA.

PL Odpowiedzialność za produkt

Zgodnie z niemiecką ustawą o odpowiedzialności za produkt, niniejszym wyraźnie oświadczamy, że nie ponosimy żadnej odpowiedzialności za szkody poniesione na skutek użytkowania naszych produktów, w przypadku gdy naprawa tych produktów nie była odpowiednio przeprowadzana przez zatwierzonego przez firmę GARDENA partnera serwisowego lub nie stosowano oryginalnych części GARDENA albo części autoryzowanych przez tę firmę.

HU Termékszavatosság

A németországi termékszavatossági törvénnyel összhangban ezennel nyomatékosan kijelentjük, hogy nem vállalunk felelősséget a termékeinkben keletkezett olyan károkért, amelyek valamely GARDENA által jóváhagyott szervizpartner által nem megfelelően végzett javításból adódtak, vagy amely során nem eredeti GARDENA alkatrészeket vagy a GARDENA által jóváhagyott alkatrészeket használtak fel.

CS Odpovědnost za výrobek

V souladu s německým zákonem o odpovědnosti za výrobek tímto výslovně prohlašujeme, že nepřijímáme žádnou odpovědnost za poškození vzniklá na našich výrobcích, kdy zmíněné výrobky nebyly řádně opraveny schváleným servisním partnerem GARDENA nebo kdy nebyly použity originální náhradní díly GARDENA nebo náhradní díly autorizované společností GARDENA.

SK Zodpovednosť za produkt

V súlade s nemeckými právnymi predpismi upravujúcimi zodpovednosť za výrobok týmto výslovne prehlasujeme, že nenesieme žiadnu zodpovednosť za škody spôsobené našimi výrobkami, v prípade ktorých neboli náležité opravy vykonané servisným partnerom schváleným spoločnosťou GARDENA alebo neboli použité diely spoločnosti GARDENA alebo diely schválené spoločnosťou GARDENA.

EL Ευθύνη προϊόντος

Σύμφωνα με τον γερμανικό νόμο περί Ευθύνης για τα Προϊόντα, με το παρόν δηλώνουμε ρητώς ότι δεν αποδεχόμαστε καμία ευθύνη για τυχόν ζημιές που προκύπτουν από τα προϊόντα μας εάν αυτά δεν έχουν επισκευαστεί σωστά από κάποιον εγκεκριμένο συνεργάτη επισκευών της GARDENA ή εάν δεν έχουν χρησιμοποιηθεί αυθεντικά εξαρτήματα GARDENA ή εξαρτήματα εγκεκριμένα από την GARDENA.

I1

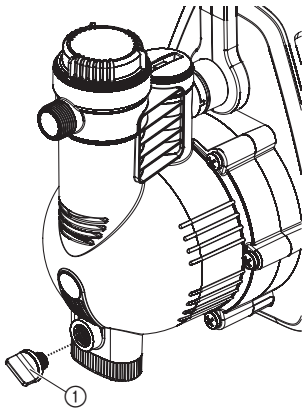

I2

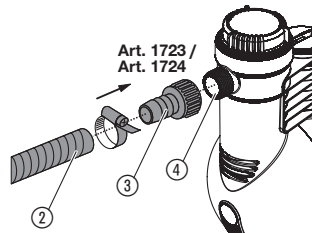

I3

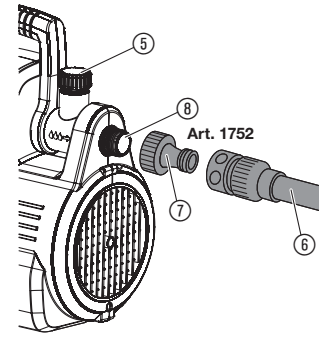

O1

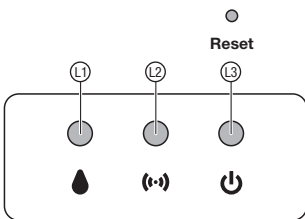

O2

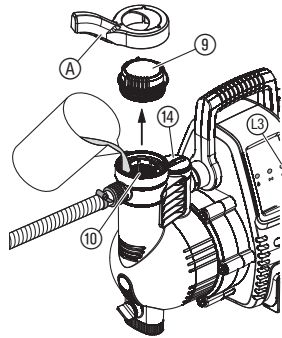

O3

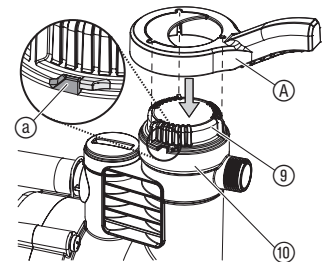

M1

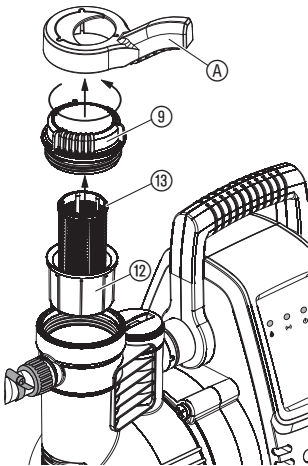

M2

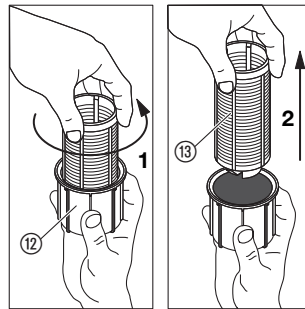

M3

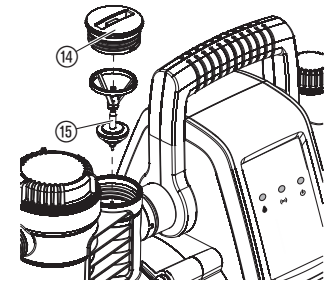

S1

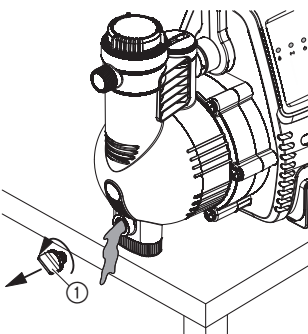

T1

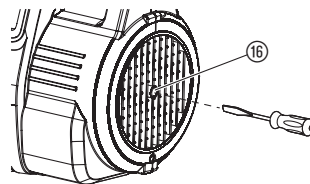

T2

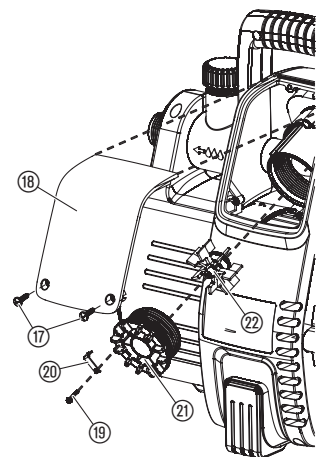

EN

1. SAFETY	9
2. INSTALLATION.....	9
3. OPERATION.....	10
4. MAINTENANCE	11
5. STORAGE	11
6. TROUBLESHOOTING	11
7. TECHNICAL DATA	12
8. ACCESSORIES	12
9. SERVICE/WARRANTY.....	13

Translation of the original instructions.



This product may be used under supervision, or if instruction regarding the safe use of the product has been provided and the resulting dangers have been understood, by children aged 8 and above, as well as by persons with physical, sensory or mental disabilities or a lack of experience and knowledge. Children must not be allowed to play with the product. Cleaning and user maintenance must not be performed by children without supervision. The use of this product by young people under the age of 16 is not recommended.

Intended use:

The **GARDENA smart Automatic Home & Garden Pump** is intended for private use in the home and hobby garden and is not intended to be used for operating irrigation equipment and systems in public gardens. It can be used for pumping rainwater, tap water and chlorinated water.

The **GARDENA smart Automatic Home & Garden Pump** can only be programmed together with the **GARDENA smart Gateway Art. 19000**.

The product is not intended for continuous operation (e.g. industrial applications, continuous circulating operation).

DANGER! Corrosive, easily combustible, aggressive or explosive liquids (such as gasoline, petroleum or nitrothinner), saltwater and food intended for consumption must not be pumped.

Pressure amplification:

If you use the pump for pressure amplification, the maximum permissible internal pressure must not exceed 6 bar (on the pressure side). With this in mind, the pump pressure must be added to the pressure to be amplified.

- Example: pressure at the tap = 1.0 bar.
Maximum pressure of the smart Automatic Home & Garden Pump = 5.0 bar.
Total pressure = 6.0 bar.

1. SAFETY

IMPORTANT!

Read the operator's manual carefully before use and keep for future reference.

Symbols on the product:



Read operator's manual.

General safety warnings

Electrical safety



DANGER! Electric shock!

Risk of injury due to electric current.

→ The product must be supplied through a residual current device (RCD) having a rated residual operating current not exceeding 30 mA.



DANGER! Electric shock!

Risk of injury due to electric current.

→ Disconnect the product from the mains before you maintain or replace parts. Thereby the disconnected socket must be in the visual range.

Safe operating practices

The water temperature should not exceed 35 °C.

The pump must not be used when people are in the water.

Leaking lubricants can contaminate the pumped liquid.

Circuit breakers

Dry-running protection: If no water is pumped (undercurrent) the pump switches off automatically.

Anti-lock protection: If the motor blocks (overcurrent), the pump switches off automatically.

Additional safety warnings

Electrical safety



DANGER! Cardiac arrest!

This product makes an electromagnetic field while it operates. This field may under some conditions interfere with active or passive medical implants. To decrease the risk of conditions that can possibly injure or kill, we recommend persons with medical implants to speak with their physician and the medical implant manufacturer before you operate the product.



DANGER! Electric shock!

The product must not be operated if there are people in the swimming pool or garden pond.

→ Make sure that the electrical plug and socket connections are fitted in an area which cannot be flooded.

→ Protect the power plug from moisture.

Connecting cable



DANGER! Electric shock!

With a cut off mains plug, moisture can get into electrical parts via the mains cable and cause a short circuit.

→ Do not cut the mains plug off (e.g. to feed through a wall).

If the supply cord is damaged, it must be replaced by the manufacturer, its service agent or similarly qualified persons in order to avoid a hazard.

According to DIN VDE (German Electrical Engineers' Association) 0620, mains power cables and extension cables must not have a smaller cross-section than the rubber-sheathed cables of the designation H07RN-F.

The cable length must be at least 10 m.

Data indicated on the type plate must match technical data of the mains supply.

Disconnect the product from the mains when it is not in use.

Protect plug and power cable from heat, oil and sharp edges.

Do not use the power cable to carry or to unplug the pump.

As an additional safety device an approved safety switch can be used.

→ Please ask your electrician for his advice.

Only use extension cables with earth connectors for operating this pump.

A damaged pump must not be used.

Before operating the pump look and see if there is any damage to the pump (especially to the power cable and plug).

→ In case of damage, please have the pump checked by our GARDENA Service Centre.

Personal safety



DANGER! Risk of suffocation!

Small parts can be easily swallowed. There is also a risk that the poly-bag can suffocate toddlers. Keep toddlers away when you assemble the product.



DANGER! Risk of injury due to hot water!

If the electronic control is defective or if the water supply on the intake side of the pump fails, any water remaining in the pump may heat up, generating a risk of injuries caused by hot water on leakage.

→ Disconnect the pump from the mains, let the water cool (approx. 10 – 15 min.) and secure the water supply on the intake side before putting into operation again.

Do not use the product while you are tired or under the influence of drugs, alcohol or medication. A moment of inattention while you operate the product may result in serious personal injury.

When connecting the pump to the water supply system, the country-specific sanitary regulations must be observed to prevent water not of drinking water quality being drawn back in.

When water flows through the pump it is no drinking water anymore.

When using the product, cover hair and do not wear scarves and other loose items of clothing.

Make sure that no children or unauthorised persons are within reach of the pump and the pumped medium without supervision.

In order to avoid dry-running of the pump, take care that the end of the suction hose is always submerged into the water.

→ Before each operation, fill the pump with liquid to be pumped (approx. 2 to 3 l).

The pump must be located on solid, even ground, protected from flooding.

Take care that the pump cannot fall into water.

Very fine sand can pass through the integrated filter (mesh size 0.45 mm) and cause accelerated wear in the hydraulic parts.

→ For sandy water, you should additionally use the **GARDENA Pump Preliminary Filter, art. 1730** (mesh size 0.1 mm).

The temperature of the pumped liquid must be between 2 °C to 35 °C.

Only stow the product in temperatures between 2 °C to 70 °C.

2. INSTALLATION



DANGER! Electric shock!

Risk of injury due to electric current.

→ Disconnect the product from the mains before you install the product.

Installation location [Fig. I1]:

The pump must be installed in a location with sufficient ventilation in the area of the ventilation slots. It must be at a distance of at least 5 cm from the walls. No dirt contamination (e.g. sand or soil) may be sucked in through the ventilation slots.

Set up the pump so that it is prevented from slipping and that an appropriately large collecting vessel for draining the pump or the system can be placed under the drain screw ①.

Install the pump at a safe distance (min. 2 m) from the pumping medium.

If possible, install the pump higher than the surface of the water to be pumped. If this is not possible, install a vacuum-resistant shut-off device between the pump and the suction hose to allow the integrated filter to be cleaned.

If the system is permanently installed, appropriate shut-off devices must be installed on the input and output sides. Important for maintenance and cleaning work on the pump or for shutdown, for example.

Connections:



CAUTION!

The GARDENA connection pieces on the intake and delivery sides may only be tightened by hand. Check whether the seal ring is present and undamaged before screwing the suction hose onto the suction inlet. When using metal connections, damage could occur on the connection thread due to inappropriate assembly. Therefore, screw on the connection fittings with the upmost care. Use sealing tape only for sealing metallic connection fittings.

Suction side:

Do not use modular water hose components on the suction side! A vacuum-tight suction hose must be used e.g.:

- GARDENA Suction Hose Art. 1411/1418
- GARDENA Bore Hole Suction Hose Art. 1729
- GARDENA Suction Hose sold by the metre with GARDENA Hose Clamp Art. 7192/7191.

If very fine dirt is present, we recommend the use of a GARDENA pump preliminary filter Art. 1730/1731 in addition to the integrated filter.

To reduce the pump repriming time, we recommend to use a suction hose with backflow preventer, which prevents the suction hose emptying automatically when the pump is switched off.

Important for fixed installation:

For greater suction heads, use a suction hose with a small diameter (3/4").

Pressure side:

A pressure-resistant hose must be used on the pressure side, e.g.:

- GARDENA Garden Hose (3/4") Art. 18113 with GARDENA Connection Set Art. 1752.

Important for fixed installation:

If the product is permanently installed in an enclosed space, only flexible hoses (e.g. reinforced hoses) may be used for connecting the service water supply, rather than rigid piping. Flexible hoses will reduce the noise level and prevent damage caused by pressure surges. Install fixed pipes at an upward gradient on the first 2 m only. To avoid damage to the thread, ensure careful and accurate installation when using metal connections.

To connect the suction hose [Fig. I2]:

1. Screw the suction hose fitting ③ onto the suction inlet ④ and tighten it by hand.
2. Slide the suction hose ② onto the suction hose fitting ③ and secure it e.g. with a GARDENA Hose Clamp Art. 7192/7191.
3. For suction head exceeding 4 m secure the suction hose (e.g. by fastening it to a wooden post).
The pump and the suction hose are relieved from the weight of the water.

To connect the pressure hose [Fig. I3]:

The pressure hose can be connected either to the delivery side 33.3 mm (G1)-thread of the 120° swivelling connection ⑤ and/or of the horizontal connection ⑥.

1. Screw the tap connector ⑦ onto the pressure outlet ⑤/⑥ and tighten it by hand.

2. Connect the pressure hose with hose connector ⑥ onto the tap connector ⑦.

3. OPERATION

Operation with the GARDENA smart system App:

You can use the GARDENA smart system app to control all smart system products from anywhere at any time. You can download the free GARDENA smart system app from the Apple App Store or from the Google Play Store.

In order to include, a GARDENA smart Gateway with internet connectivity is needed. All GARDENA smart products are integrated via the app. Follow the instructions inside the App.

Settings/Display via the app:

- Language
- Current flow
- Current pressure
- Standby
- Turn on pressure
- Total volume counter
- Frost Warning
- Leakage warning
ON (60 min)
ON (2 min)
OFF
- Errors

LED displays of the pump [Fig. O1]:

① Watering LED/Error LED

- Green: Water flows
- Off: Standby (when ③ illuminates)
- Red flashing: Error (see 6. TROUBLESHOOTING)

② Connection-LED

- Green flashing: Wait for connection
- Green – orange – red: Signal quality
- Red flashing: Inclusion not done

③ Power-LED

- Green: Power on
- Off: Power off

Reset Button

The smart Automatic Home & Garden Pump will be reset to the factory settings.

→ Push the Reset button for a short time.

New connection.

– or –

→ Push and hold down the Reset button for at least 5 seconds.

Cancels the existing connection and allows a new connection to be established, e.g. different Gateway.

To start the smart Automatic Home & Garden Pump [Fig. O2/O3]:



DANGER! Electric shock!

Risk of injury due to electric current.

→ Disconnect the product from the mains before you fill the pump.

NOTE: The specified maximum self-priming level (see 7. TECHNICAL DATA) is reached only when the pump is full and the pressure hose is held up high directly upstream of the pressure output during the first self-priming phase. This ensures that the pumped medium cannot leak from the pressure hose. When using a full suction hose with a check valve, it is not necessary to hold up the pressure hose.

1. Unscrew the lid ⑨ of the filter chamber with the spanner ④ provided.
2. Slowly fill in the liquid to be pumped via the filler connection ⑩ up to the overflow (approx. 2 to 3 l) until the water level no longer drops under the suction side inlet or the water flows out at the horizontal connector.
3. **With fixed installation:** Unscrew the cover ⑭ and fill with liquid until it flows towards the horizontal connector.
4. Empty any water remaining in the delivery hose so that the air can escape during filling and priming.
5. Open any shut-off devices in the delivery line (watering accessories, tap, etc.) so that air can escape before the priming procedure begins.

- With fixed installation:** If the delivery line cannot be emptied due to fixed installation, unscrew the cover (14). Considerable amounts of liquid may escape. Please keep a sufficiently large receptacle at hand for collection.
- Tighten the lid (15) of the filter chamber up to the stopper (16).
- Without fixed installation:** Lift up the delivery hose just behind the pressure outlet.
- Plug the power plug of the connecting cable into a mains socket.
The pump starts after approx. 3 seconds and the power-LED illuminates green.

The suction process can take up to 6 min. If no water is pumped afterwards, the pump will shut down automatically and display Error 2 (see 6. TROUBLESHOOTING).

- Close shut-off devices in the delivery pipeline again when the pump begins to deliver water continuously.

The pump turns off automatically approx. 10 seconds after closing the shut-off device.

The pump is ready for operation (Standby).

Electronic control:

The pump features an electronic controller.

If the pressure level falls below the start-up pressure, the pump is started automatically.

As soon as the water supply is no longer required, the pump is switched off automatically.

Low quantity programme and leakage warning:

Leakage warning:

In the event of a leakage or a dripping tap, the pressure constantly falls below the turn-on pressure and the pump switches itself on and off continuously.

If the pump is constantly switched on and off, the pump switches off automatically to prevent unwanted water leakage (error 4 "Leakage warning" is displayed).

Low quantity programme

To prevent the pump from switching off earlier when used with low quantity of water (e.g. washing machines or drip irrigation), the duration of the low quantity programme until the leakage warning is activated can be set (see **GARDENA smart system App**/leakage warning).

Switching the pump on and off cyclically during the small quantity program has no effect on the service life of the pump.

Use of washing machines

(Leakage warning set to 60 min.):

Upon completion of the low quantity water supply cycle in washing machines, the 60-minute operating interval of the low quantity programme is automatically reset to normal operation of the pump and allows a trouble-free use of the washing machine for > 60 minutes.

Use without low quantities of water

(Leakage warning set to 2 min.):

If no low quantities of water are required, the leakage warning can be reduced to 2 minutes. This enables maximum protection in the event of a leakage.

For continuous drip irrigation

(Leakage warning set to OFF):

If the low quantity programme is to be used for more than 60 minutes, the leakage warning can be deactivated (OFF).

Caution! The pump is then no longer protected by the leakage warning.

4. MAINTENANCE



DANGER! Electric shock!

Risk of injury due to electric current.

→ Disconnect the product from the mains before you maintain the product.

To clean the filter [Fig. M1/M2]:

- If applicable, close all the shutoff devices on the intake side.
- Loosen the lid (9) of the filter chamber with the spanner (A) provided.
- Remove the filter unit (12)/(13) vertically upwards.
- Hold the cup (12) firmly, turn the filter (13) counterclockwise **1** and remove the filter **2** (bayonet fitting).

- Clean the cup (12) under running water and clean the filter (13) e.g. with a soft brush.
- Assemble the filter again in reverse order.
- Start the pump (see 3. OPERATION).

To clean the check valve [Fig. M3]:



CAUTION!

The pump must not be operated without the check valve.

- If applicable, close all the shut-off devices on the intake side.
- Open all tapping points so that the pressure escapes on the pressure side. Now close the tapping points again so that the connected pipes do not drain via the pump.
- Loosen the cover (14) of the check valve with a suitable tool.
- Remove the check valve (15) and clean it under running water.
- Assemble the check valve (15) again in reverse order.
- Start the pump (see 3. OPERATION).

5. STORAGE

To put into storage [Fig. S1]:

The product must be stored away from children.

- Disconnect the pump from the mains.
- Open the consumer on the pressure side.
- Remove the connected hoses on the pressure and suction side.
- Unscrew drain bolt (1).
- Tilt the pump to the suction and pressure side until water is no longer discharged from either side.
- Store the pump in a dry, enclosed and frost-free place.

Disposal:

(in accordance with RL2012/19/EC)

The product must not be disposed of to normal household waste. It must be disposed of in line with local environmental regulations.



IMPORTANT!

→ Dispose of the product through or via your municipal recycling collection centre.

6. TROUBLESHOOTING



DANGER! Electric shock!

Risk of injury due to electric current.

→ Disconnect the product from the mains before you troubleshoot the product.

To troubleshoot with the error diagnosis system [Fig. O1]:

The pump is equipped with an error diagnosis system which indicates various error states via the error LED (1) and indicates the cause and the remedy of various error states via the **GARDENA smart system App**.

- Disconnect the pump from the mains.**
- Make the remedy indicated in the **GARDENA smart system App** (or the respective remedy from the table below).
- Start the pump again.
- If the error is not fixed, go back to step 1 and call up the next possible error.
- When the error is fixed, the error display is cleared.
The pump is ready for operation again.

Problem	Possible Cause	Remedy
Error-LED flashes 1 time (with a 2 second break)	<i>The pump does not pump water for 30 seconds during the initial operation.</i>	
Pump does not suck water	Pump was not sufficiently filled with liquid to be pumped.	→ Fill the pump and make sure that water does not drain out on the pressure side during the suctioning process (see 3. OPERATION).
	Air cannot escape on the pressure side, because the pressure side outlets are closed.	→ Open the pressure side outlets (see 3. OPERATION).

Problem	Possible Cause	Remedy
Pump does not start	The pump housing has heated up and the thermal circuit breaker has been activated.	<ol style="list-style-type: none"> 1. Open possible shut-off device in the pressure line (release pressure). 2. Ensure sufficient ventilation and let the pump cool down for 20 min.
	The impeller is blocked.	<ol style="list-style-type: none"> 1. Loosen the impeller (see "To loosen the impeller"). 2. Let the pump cool down for 20 min.
	The flow sensor is dirty.	→ Clean the flow sensor (see "To clean the flow sensor").

Error-LED flashes 2 times (with a 2 second break) *The pump does not pump water for 6 minutes during the initial operation.*

Pump does not suck water	Problem on the suction side.	<ul style="list-style-type: none"> → Immerse the suction hose end under water. → Eliminate any leak on the suction side. → Clean the check valve on the suction line and check the installation direction. → Clean the suction filter on the suction hose end. → Clean the filter lid seal and turn the lid until the stopper (see 4. MAINTENANCE). → Clean the filter in the pump.
	Suction hose deformed or bent.	→ Use a new suction hose.

Pump does not start	The thermal circuit breaker has been activated (motor overheated).	→ Let the pump cool down for 20 min.
---------------------	--	--------------------------------------

Error-LED flashes 3 times (with a 2 second break) *The pump does not pump water for 30 seconds during the current operation.*

Water supply disrupted on the suction side	Problem on the suction side.	<ul style="list-style-type: none"> → Immerse the suction hose end under water. → Eliminate any leak on the suction side. → Clean the check valve on the suction line and check the installation direction. → Clean the suction filter on the suction hose end. → Clean the filter lid seal and turn the lid until the stopper (see 4. MAINTENANCE). → Clean the filter in the pump.
	Suction hose deformed or bent.	→ Use a new suction hose.

Pump does not start	The thermal circuit breaker has been activated (motor overheated).	→ Let the pump cool down for 20 min.
	The flow sensor is dirty.	→ Clean the flow sensor (see "To clean the flow sensor").

Error-LED flashes 4 times (with a 2 second break) *The pump switches off during on-going operation after 60 minutes or 2 minutes.*

Leakage warning is activated	Leak on pressure side (e.g. dripping tap).	→ Eliminate any leak on the pressure side.
	The maximum duration of the set leakage warning (low quantity program 60 min. or 2 min.) has been exceeded	<ul style="list-style-type: none"> → Increase the duration of the leakage warning. → Increase the water consumption
	The check valve is blocked.	→ Clean the check valve (see "To clean the check valve").
	The flow sensor is dirty.	→ Clean the flow sensor (see "To clean the flow sensor").

Pump does not start or stops suddenly during operation	Mains plug is disconnected.	→ Connect the mains plug.
	Power failure.	→ Check the fuse and the cables.
	RCD has triggered (residual current).	→ Disconnect the pump and contact the GARDENA Service.
	Electrical interruption.	→ Disconnect the pump and contact the GARDENA Service.

To loosen the impeller [Fig. T1]:

If the impeller is stuck due to dirt, the **Error LED flashes 1 time (with a 2 second break)**.

1. Turn the motor shaft (16) with a screw driver.
This will loosen the blocked impeller.
2. Start the pump (see 3. OPERATION).

To clean the flow sensor [Fig. T2]:

If the flow sensor is stuck due to dirt, the **Error LED flashes (with a 2 second break)**.

1. Loosen both screws (17).
2. Remove the cover (18).
3. Loosen the screw (19) and remove the clip (20).
4. Loosen the cap (21) counterclockwise (e.g. with a screwdriver).
5. Remove and clean the impeller (22).
6. Clean the housing of the flow sensor.
7. Assemble the impeller (22) again in reverse order.
8. First insert the cover (18) at the top and then tighten both screws (17) at the bottom.
9. Start the pump (see 3. OPERATION).



NOTE: For any other malfunctions please contact the GARDENA service department. Repairs must only be done by GARDENA service departments or specialist dealers approved by GARDENA.

7. TECHNICAL DATA

smart Automatic Home & Garden Pump	Unit	Value (Art. 19080)
Mains voltage	V (AC)	230
Mains frequency	Hz	50
Rated Power / Standby consumption	W	1300 / 1,5
Connection cable	m	1.5 (H07RN-F)
Max. delivery capacity	l/h	5000
Max. pressure	bar	5.0
Max. delivery head	m	50
Max. suction height	m	8
Cut-in pressure	bar	2.0 – 2.8 ± 0.2
Permitted internal pressure (delivery side)	bar	6
SRD:		
Frequency range	MHz	863 – 870
Maximum power	mW	25
Free field radio range (approx.)	m	100
Weight	kg	13.4
Sound power level $L_{WA}^{1)}$: measured/guaranteed Uncertainty $k_{WA}^{1)}$	dB (A)	77 / 79 2.19

Measuring process complying with: ¹⁾ RL 2000/14/EC

8. ACCESSORIES

GARDENA Suction Hoses	Kink and vacuum-resistant, sold by the metre with 19 mm (3/4"), 25 mm (1") or 32 mm (5/4") diameter without fittings or in fixed lengths complete with fittings, suction filter and backflow preventer.	
GARDENA Suction Hose Fittings	For vacuum-resistant connection of the pump to the suction hose sold by the metre.	Art. 1723/1724
GARDENA Suction Filter with Backflow Preventer	To equip suction hoses with Backflow Preventer sold by the metre.	Art. 1726/1727
GARDENA Bore Hole Suction Hose	For vacuum-resistant connection of the pump to boreholes or pipe networks. Length 0.5 m. With 33.3 mm (G1) female thread at both ends.	Art. 1729
GARDENA Pump Preliminary Filter	Recommended for pumping sandy water.	Art. 1730/1731
GARDENA Pump Connection Set	Connection Set for 1/2" Pressure Hoses.	Art. 1750
GARDENA Pump Connection Set	Connection Set for 3/4" Pressure Hoses.	Art. 1752

9. SERVICE/WARRANTY

Service:

Please contact the address on the back page.

Warranty:

In the event of a warranty claim, no charge is levied to you for the services provided.

GARDENA Manufacturing GmbH offers a 2-year warranty for this product (from the date of purchase) if the product has been used exclusively for private purposes. This manufacturer's warranty does not apply to used products purchased from a secondary market. This warranty includes all significant defects of the product that can be proved to be material or manufacturing faults. This warranty is fulfilled by supplying a fully functional replacement product or by repairing the faulty product sent to us free of charge; we reserve the right to choose between these options. This service is subject to the following provisions:

- The product was used for its intended purpose as per the recommendations in the operating instructions.
- Neither the purchaser nor a third party has attempted to repair the product.
- Only original GARDENA spare and wear parts were used.

Normal wear and tear of parts and components, optical changes, as well as wear parts and consumables, are excluded from the warranty.

This manufacturer's warranty does not affect warranty entitlements against the dealer/retailer.

If problems arise with this product, please contact our Service department. In the event of a warranty claim, please send the defective product together with a copy of the purchase receipt and a description of the defect, sufficiently stamped, to the GARDENA service address on the back page.

Consumables:

The impeller, filter and jet nozzle are consumables and are not included in the warranty.

Pumpen-Kennlinien
Performance characteristics
Courbes de performance
Prestatiegrafieken
Kapacitetskurva
Ydelses karakteristika
Pumpun ominaiskäyrä
Pumpekarakteristikk
Curva di rendimento
Curva característica de la bomba
Charakterystyka pompy
Szivattyú-jelleggörbe
Charakteristika čerpadla
Charakteristiky čerpadla
Χαρακτηριστικό διάγραμμα

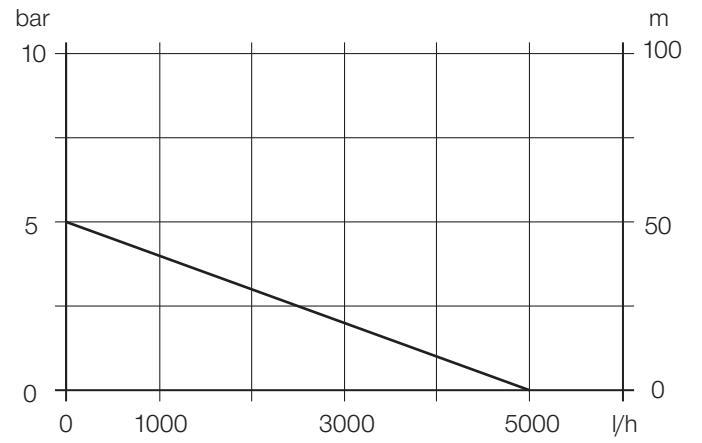

<p>DE EU-Konformitätserklärung Der Unterzeichner, GARDENA Germany AB, PO Box 7454, S-103 92 Stockholm, Schweden, bescheinigt hiermit, dass die nachstehend aufgeführten Produkte bei Verlassen des Werks die harmonisierten EU-Leitlinien, EU-Normen für Sicherheit und besondere Normen erfüllen. Dieses Zertifikat verliert seine Gültigkeit, wenn die Produkte ohne unsere Genehmigung verändert werden.</p>	<p>IT Dichiarazione di conformità CE La sottoscritta GARDENA Germany AB, PO Box 7454, S-103 92 Stockholm, Svezia, certifica che il prodotto qui di seguito indicato, nei modelli da noi commercializzati, è conforme alle direttive armonizzate UE nonché agli standard di sicurezza UE e agli standard specifici di prodotto. Qualunque modifica apportata al prodotto senza nostra specifica autorizzazione invalida la presente dichiarazione.</p>
<p>EN EC Declaration of Conformity The undersigned, GARDENA Germany AB, PO Box 7454, S-103 92 Stockholm, Sweden, hereby certifies that, when leaving our factory, the units indicated below are in accordance with the harmonised EU guidelines, EU standards of safety and product specific standards. This certificate becomes void if the units are modified without our approval.</p>	<p>ES Declaración de conformidad CE El abajo firmante, GARDENA Germany AB, PO Box 7454, S-103 92 Stockholm, Suecia, certifica por la presente que, cuando salen de la fábrica, las unidades indicadas a continuación cumplen las normas de armonización de la UE, las normas de la UE sobre seguridad y las normas específicas del producto. Este certificado quedará sin efecto si se modifican las unidades sin nuestra autorización.</p>
<p>FR Déclaration de conformité CE Le constructeur, soussigné : GARDENA Germany AB, PO Box 7454, S-103 92 Stockholm, Suède, déclare qu'à la sortie de ses usines le matériel neuf désigné ci-dessous était conforme aux prescriptions des directives européennes énoncées ciaprès et conforme aux règles de sécurité et autres règles qui lui sont applicables dans le cadre de l'Union européenne. Toute modification apportée à cet appareil sans notre accord annule la validité de ce certificat.</p>	<p>PL Deklaracja zgodności WE Niżej podpisany przedstawiciel firmy GARDENA Germany AB, PO Box 7454, S-103 92 Stockholm, Szwecja, niniejszym oświadcza, że podane poniżej wyroby opuszczające fabrykę są zgodne ze zharmonizowanymi normami UE oraz z obowiązującymi w UE przepisami bezpieczeństwa i normami dotyczącymi danego produktu. Modyfikacja wyrobów bez naszej zgody powoduje unieważnienie niniejszego certyfikatu.</p>
<p>NL EG-conformiteitsverklaring De ondergetekende, GARDENA Germany AB, PO Box 7454, S-103 92 Stockholm, Zweden, verklaart hierbij dat de producten die hieronder staan vermeld, wanneer ze onze fabriek verlaten, in overeenstemming zijn met de geharmoniseerde Europese richtlijnen, EU-normen voor veiligheid en productspecifieke normen. Dit certificaat vervalt als de producten worden aangepast zonder onze toestemming.</p>	<p>HU EK megfeleléségi nyilatkozat Alulírott GARDENA Germany AB, PO Box 7454, S-103 92 Stockholm, Svédország, ezzel tanúsítja, hogy az alábbiakban leírt egységek a gyár elhagyásakor megfeleltek a harmonizált uniós előírásoknak és biztonságai és termékspecifikus szabványoknak. Ez a tanúsítvány érvényét veszti, ha az egységeket jóváhagyásunk nélkül átalakítják.</p>
<p>SV EG-försäkran om överensstämmelse Undertecknad firma GARDENA Germany AB, PO Box 7454, S-103 92 Stockholm, Sverige, intygar härmed att nedan nämnda produkter, när de lämnar vår fabrik, överensstämmer med EU:s riktlinjer, EU:s säkerhetsstandarder och produktspecifika standarder. Detta intyg skall ogiltigförklaras om produkten ändras utan vårt godkännande.</p>	<p>CS Prohlášení o shodě ES Niže uvedená společnost GARDENA Germany AB, PO Box 7454, S-103 92 Stockholm, Švédsko, tímto potvrzuje, že při opuštění naší továrny jsou jednotky uvedené níže v souladu s harmonizačními pokyny EU, standardy EU ohledně bezpečnosti a specifickými produktovými standardy. Tento certifikát pozbyvá platnosti, pokud dojde k úpravě jednotek bez našeho schválení.</p>
<p>DA EU-overensstemmelseerklæring Undertegnede, GARDENA Germany AB, PO Box 7454, S-103 92 Stockholm, Sverige, erklærer hermed, at nedenfor anførte enheder er i overensstemmelse med de harmoniserede EU-rettlinjer, EU-standarder for sikkerhed og produktspecifikke standarder, når de forlader fabrikken. Denne erklæring ugyldiggøres, hvis enhederne ændres uden vores godkendelse.</p>	<p>SK EÚ vyhlásenie o zhode Dolu podpísaná spoločnosť GARDENA Germany AB, PO Box 7454, S-103 92 Stockholm, týmto osvedčuje, že nižšie uvedené jednotky boli v súlade s harmonizačnými usmerneniami EÚ, normami EÚ v oblasti bezpečnosti a špecifickými normami týkajúcimi sa produktu v čase opustenia výrobného závodu. Toto osvedčenie stráca platnosť, ak boli jednotky zmenené bez nášho súhlasu.</p>
<p>FI EY-vaatimustenmukaisuusvakuutus GARDENA Germany AB, PO Box 7454, S-103 92 Stockholm, Ruotsi, vakuuttaa täten, että alla mainitut laitteet ovat tehtaalta lähtessään yhdenmukaistettujen EU-säännösten, EU:n turvastandardien ja tuotekohtaisten standardien mukaisia. Tämä vakuutus mitätöityy, jos laitteita muutetaan ilman hyväksyntää.</p>	<p>EL Δήλωση Συμμόρφωσης EK Η υπογεγραμμένη εταιρεία, GARDENA Germany AB, PO Box 7454, S-103 92 Stockholm, Σουηδία, πιστοποιεί ότι, κατά την έξοδο από το εργοστάσιο, οι μονάδες που αναφέρονται κατωτέρω συμμορφώνονται με τις εναρμονισμένες οδηγίες ΕΕ, τα πρότυπα ασφαλείας της ΕΕ και τα συγκεκριμένα πρότυπα προϊόντος. Αυτό το πιστοποιητικό καθίσταται άκυρο εάν οι μονάδες έχουν τροποποιηθεί χωρίς την έγκρισή μας.</p>

<p>Produktbezeichnung: Description of the product: Désignation du produit : Beschrijving van het product: Beskrivning av produkten: Beskrivelse af produktet: Tuotteen kuvaus: Descrizione del prodotto: Descripción del producto: Opis produktu: A termék leírása: Popis výrobku: Popis produktu: Περιγραφή του προϊόντος:</p>	<p>smart Haus- & Gartenautomat smart Automatic Home & Garden Pump Automate smart pour la maison et le jardin smart elektronische hydrofoorpomp smart pumpautomat för hem och trädgård smart hus- & haveautomat Älykäs smart paine- ja puutarhapumppu smart Pompa automatica per uso domestico e giardino Estación de bombeo para casa y jardín smart smart hydrofor elektronikzny smart háztartási- és kerti automata szivattyú smart domácí a zahradní automat smart domácí a záhradný automat Πιστική αντλία νερού οικιακής χρήσης & κήπου smart</p>	<p>Harmonisierte EN-Normen / Harmonised EN: EN ISO 12100 EN 60335-1 EN 60335-2-41</p> <p>Schall-Leistungspegel: Noise level: Niveau sonore : Geluidsniveau: Ljudnivå: Støjniveau: Äänitaso: Livello acustico: Nivel de ruido: Poziom hałas: Zajszint:</p> <p>gemessen/ garantiert measured/ guaranteed mesuré/ garanti gemeten/ gegarandeerd uppmätt/ garanterad mält/ garanteret mitattu/ taattu misurato/ garantito medido/ garantizado zmierzony/ gwarantowany mért/ garantált</p>	<p>EN 301489-1 V1.9.2 EN 301489-3 V1.6.1</p> <p>Hladina hluku: Hladiny hluku: Επίπεδο θορύβου: naměřená/ zaručená namerané/ zaručené μετρημένο/ εγγυημένο</p> <p>77 dB(A) / 79 dB(A)</p>
<p>Artikelnummer: Article number: Référence : Artikelnummer: Artikelnummer: Artikelnummer: Tuotenumero: Codice articolo: Referencia: Numer katalogowy: Cikkszámok: Objednací číslo: Objednávacie číslo: Κωδικός είδους:</p>	<p>19080</p>	<p>Anbringningsjahr der CE-Kennzeichnung: Year of CE marking: Année d'apposition du marquage CE : Installatiejaar van de CE-aanduiding: Märkningsår: CE-Mærkningsår: CE-merkin kiinnitysvuosi: Anno di applicazione della certificazione CE: Colocación del distintivo CE: Rok nadania oznakowania CE: CE-jelzés elhelyezésének éve:</p>	<p>Rok umístění značky CE: Rok udelenia značky CE: Έτος σήματος CE:</p> <p>2016</p>
<p>EU-Richtlinien: EC-Directives: Directives CE : EG-richtlijnen: EU-direktiv: EF-direktiver: EY-direktiivit: Direttive UE: Directiva CE: Dyrektwy WE: EK-irányelvek: Předpisy ES: Smernice EÚ: Οδηγίες EK:</p>	<p>Hinterlegte Dokumentation: GARDENA Technische Dokumentation, M. Kugler 89079 Ulm</p> <p>Deposited Documentation: GARDENA Technical Documentation, M. Kugler 89079 Ulm</p> <p>Documentation déposée: Documentation technique GARDENA, M. Kugler 89079 Ulm</p>	<p>Konformitätsbewertungs- verfahren: Nach 2000/14/EG Art. 14 Anhang V</p> <p>Conformity Assessment Procedure: according to 2000/14/EC Art.14 Annex V</p> <p>Procédure d'évaluation de la conformité : Selon 2000/14/CE art. 14 Annexe V</p>	<p>Ulm, den 07.09.2018 Ulm, 07.09.2018 Fait à Ulm, le 07.09.2018 Ulm, 07-09-2018 Ulm, 2018.09.07. Ulm, 07.09.2018 Ulmissa, 07.09.2018 Ulm, 07.09.2018 Ulm, 07.09.2018 Ulm, dnia 07.09.2018 Ulm, 07.09.2018 Ulm, 07.09.2018 Ulm, 07.09.2018 Ulm, 07.09.2018</p> <p>Der Bevollmächtigte Authorised representative Le mandataire De gevolmachtigde Auktoriserad representant Autoriseret repräsentant Valtuutettu edustaja Persona delegata La persona autorizada Πειννομοκνικ Meghatalmazott Zplnomocnenec Splnomocnený Ο εξουσιοδοτημένος</p> <p><i>Reinhard Pompe</i> Reinhard Pompe Vice President</p>

Deutschland / Germany

GARDENA
Manufacturing GmbH
Central Service
Hans-Lorenser-Straße 40
D-89079 Ulm
Produktfragen:
(+49) 731 490-123
Reparaturen:
(+49) 731 490-290
service@gardena.com

Albania

COBALT Sh.p.k.
Rr. Siri Kodra
1000 Tirana

Argentina

Husqvarna Argentina S.A.
Av.del Libertador 5954 –
Piso 11 – Torre B
(C1428ARP) Buenos Aires
Phone: (+54) 11 5194 5000
info.gardena@
ar.husqvarna.com

Armenia

Garden Land Ltd.
61 Tigran Mets
0005 Yerevan

Australia

Husqvarna Australia Pty. Ltd.
Locked Bag 5
Central Coast BC
NSW 2252
Phone: (+61) (0) 2 4352 7400
customer.service@
husqvarna.com.au

Austria / Österreich

Husqvarna Austria GmbH
Industriezeile 36
4010 Linz
Tel.: (+43) 732 77 01 01-485
service.gardena@
husqvarnagroup.com

Azerbaijan

Firm Progress
a. Aliyev Str. 26A
1052 Baku

Belgium

Husqvarna België nv/sa
Gardena Division
Rue Egide Van Ophem 111
1180 Uccle / Ukkel
Tel.: (+32) 2 720 92 12
info@gardena.be

Bosnia / Herzegovina

SILK TRADE d.o.o.
Industrijska zona Bukva bb
74260 Tešanj

Brazil

Husqvarna do Brasil Ltda
Av. Francisco Matarazzo,
1400 – 19º andar
São Paulo – SP
CNPJ: 05001-903
Tel: 0800-112252
marketing.br.husqvarna@
husqvarna.com.br

Bulgaria

AGROLAND България АД
бул. 8 Декември, №13
Офис 5
1700 Студентски град
София
Тел.: (+359) 24 66 69 10
info@agroland.eu

Canada / USA

GARDENA Canada Ltd.
100 Summerlea Road
Brampton, Ontario L6T 4X3
Phone: (+1) 905 792 93 30
info@gardenacanada.com

Chile

Maquinarias Agroforestales
Ltda. (Maga Ltda.)
Santiago, Chile
Avda. Chesterton
8355 comuna Las Condes
Phone: (+56) 2 202 4417
Dalton@maga.cl
Zipcode: 7560330

China

Husqvarna (Shanghai)
Management Co., Ltd.
富世华 (上海) 管理有限公司
3F, Benq Square B,
No207, Song Hong Rd.,
Chang Ning District,
Shanghai, PRC. 200335
上海市长宁区淞虹路207号明
基广场B座3楼, 邮编: 200335

Colombia

Husqvarna Colombia S.A.
Calle 18 No. 68 D-31, zona
Industrial de Montevideo
Bogotá, Cundinamarca
Tel. 571 2922700 ext. 105
jairo.salazar@
husqvarna.com.co

Costa Rica

Compania Exim
Euroberoamericana S.A.
Los Colegios, Moravia,
200 metros al Sur del Colegio
Saint Francis – San José
Phone: (+506) 297 68 83
exim_euro@racsa.co.cr

Croatia

Husqvarna Austria GmbH
Industriezeile 36
4010 Linz
Tel.: (+43) 732 77 01 01-485
service.gardena@
husqvarnagroup.com

Cyprus

Med Marketing
17 Digeni Akrita Ave
P.O. Box 27017
1641 Nicosia
Czech Republic
Husqvarna Česko s.r.o.
Türkova 2319/5b
149 00 Praha 4 – Chodov
Bezplatná infolinka:
800 100 425
servis@cz.husqvarna.com

Denmark

GARDENA DANMARK
Lejrvej 19, st.
3500 Værløse
Tlf.: (+45) 70 26 47 70
husqvarna@husqvarna.dk
www.gardena.com/dk

Dominican Republic

BOSQUESA, S.R.L
Carretera Santiago Licey
Km. 5 ½
Esquina Copal II.
Santiago
Dominican Republic
Phone: (+809) 736-0333
joserbosquesa@claro.net.do

Ecuador

Husqvarna Ecuador S.A.
Arupos E1-181 y 10 de
Agosto Quito, Pichincha
Tel. (+593) 22800739
francisco.jacome@
husqvarna.com.ec

Estonia

Husqvarna Eesti OÜ
Valdeku 132
EE-11216 Tallinn
info@gardena.ee

Finland

Oy Husqvarna Ab
Gardena Division
Lautatarhankatu 8 B/PL 3
00581 HELSINKI
www.gardena.fi

France

Husqvarna France
9/11 Allée des pierres mayettes
92635 Gennevilliers Cedex
France
http://www.gardena.com/fr
N° AZUR: 0 810 00 78 23
(Prix d'un appel local)

Georgia

Transporter LLC
8/57 Beliashvili street
0159 Tbilisi, Georgia
Phone: (+995) 322 14 71 71

Great Britain

Husqvarna UK Ltd
Preston Road
Aycliffe Industrial Park
Newton Aycliffe
County Durham
DL5 6UP
info.gardena@
husqvarna.co.uk

Greece

Π. ΠΑΠΑΔΟΠΟΥΛΟΣ ΑΕΒΕ
Λεωφ. Αθηνών 92
Αθήνα
T.K.104 42
Ελλάδα
Τηλ. (+30) 210 5193100
info@papadopoulos.com.gr

Hungary

Husqvarna Magyarország Kft.
Ezred u. 1-3
1044 Budapest
Telefon: (+36) 1 251-4161
vevoszolgalat.husqvarna@
husqvarna.hu

Iceland

Ó. Johnson & Kaaber
Tunguhalsi 1
110 Reykjavik
ooj@ojk.is

Ireland

Husqvarna UK Ltd
Preston Road
Aycliffe Industrial Park
Newton Aycliffe
County Durham
DL5 6UP
info.gardena@
husqvarna.co.uk

Italy

Husqvarna Italia S.p.A.
Via Santa Vecchia 15
23868 VALMADRERA (LC)
Phone: (+39) 0341.203.111
assistenza.italia@
it.husqvarna.com

Japan

KAKUICHI Co. Ltd.
Sumitomo Realty &
Development Kojimachi
BLDG., 8F
5-1 Nibannco
Chiyoda-ku
Tokyo 102-0084
Phone: (+81) 33 264 4721
m_ishihara@kaku-ichi.co.jp

Kazakhstan

LAMED Ltd.
155/1, Tazhibayevoy Str.
050060 Almaty
IP Schmidt
Abayavenue 3B
110 005 Kostanay

Korea

Kyung Jin Trading CO.,LTD.
107-4, SunDuk Bld.,
YangJae-dong,
Seocho-gu,
Seoul, (zipcode: 137-891)
Phone: (+82) (0)2 574-6300

Kyrgyzstan

Alye Maki
av. Moladaya Guardir J 3
720014
Bishkek

Latvia

Husqvarna Latvija SIA
Ulbrokas 19A
LV-1021 Rīga
info@gardena.lv

Lithuania

UAB Husqvarna Lietuva
Ateities pl. 77C
LT-52104 Kaunas
info@gardena.lt

Luxembourg

Magasins Jules Neuberger
39, rue Jacques Stas
Luxembourg-Gasperich 2549
Case Postale No. 12
Luxembourg 2010
Phone: (+352) 40 14 01
api@neuberger.lu

Mexico

AFOSA
Av. Lopez Mateos Sur # 5019
Col. La Calma 45070
Zapopan, Jalisco
Mexico
Phone: (+52) 33 3818-3434
icornejo@afosa.com.mx

Moldova

Convel S.R.L.
290A Muncesti Str.
2002 Chisinau

Netherlands

Husqvarna Nederland B.V.
GARDENA Division
Postbus 50131
1305 AC ALMERE
Phone: (+31) 36 521 00 10
info@gardena.nl

Neth. Antilles

Jonka Enterprises N.V.
Sta. Rosa Weg 196
P.O. Box 8200
Curaçao
Phone: (+599) 9 767 66 55
pgm@jonka.com

New Zealand

Husqvarna New Zealand Ltd.
PO Box 76-437
Manukau City 2241
Phone: (+64) (0) 9 9202410
support.nz@husqvarna.co.nz

Norway

Husqvarna Norge AS
Gardena Division
Trøskenveien 36
1708 Sarpsborg
info@gardena.no

Peru

Husqvarna Perú S.A.
Jr. Ramón Cárcamo 710
Lima 1
Tel: (+51) 1 3320400 ext. 416
juan.remuzgo@
husqvarna.com

Poland

Husqvarna
Poland Spółka z o.o.
ul. Wysockiego 15 b
03-371 Warszawa
Phone: (+48) 22 330 96 00
gardena@husqvarna.com.pl

Portugal

Husqvarna Portugal, SA
Lagoa - Albarraque
2635 - 595 Rio de Mouro
Tel.: (+351) 21 922 85 30
Fax : (+351) 21 922 85 36
info@gardena.pt

Romania

Madex International Srl
Soseaua Odaii 117-123,
RO 013603 București, S1
Phone: (+40) 21 352.76.03
madex@ines.ro

Russia / Россия

ООО „Хускварна“
141400, Московская обл.,
г. Химки,
улица Ленинградская,
владение 39, стр.6
Бизнес Центр
„Химки Бизнес Парк“,
помещение ОВ02_04
http://www.gardena.ru

Serbia

Domel d.o.o.
Autoput za Novi Sad bb
11273 Belgrade
Phone: (+381) 1 18 48 88 12
miroslav.jejina@domel.rs

Singapore

Hy-Ray PRIVATE LIMITED
40 Jalan Pemimpin
#02-08 Tat Ann Building
Singapore 577185
Phone: (+65) 6253 2277
shiyiing@hyray.com.sg

Slovak Republic

Husqvarna Česko s.r.o.
Türkova 2319/5b
149 00 Praha 4 – Chodov
Bezplatná infolinka:
800 154 044
servis@sk.husqvarna.com

Slovenia

Husqvarna Austria GmbH
Industriezeile 36
4010 Linz
Tel.: (+43) 732 77 01 01-485
service.gardena@
husqvarnagroup.com

South Africa

Husqvarna
South Africa (Pty) Ltd
Postnet Suite 250
Private Bag X6,
Cascades, 3202
South Africa
Phone: (+27) 33 846 9700
info@gardena.co.za

Spain

Husqvarna España S.A.
Calle de Rivas nº 10
28052 Madrid
Phone: (+34) 91 708 05 00
atencioncliente@gardena.es

Suriname

Agrofix n.v.
Verlengde Hogestraat #22
Phone: (+597) 472426
agrofix@sr.net
Pobox : 2006
Paramaribo
Suriname – South America

Sweden

Husqvarna AB
Gardena Division
S-561 82 Husqvarna
Gardenaorder@husqvarna.se

Switzerland / Schweiz

Husqvarna Schweiz AG
Consumer Products
Industriestrasse 10
5506 Mägenwil
Phone: (+41) (0) 62 887 37 90
info@gardena.ch

Turkey

Dost Bahçe Diş Ticaret
Müessesilik A.Ş
Yunus Mah. Adil Sok. No:3
Ic Kapi No: 1 Kartal
34873 Istanbul
Phone: (+90) 216 38 93 939
info@dostbahce.com.tr

Ukraine / Україна

ТОВ «Хускварна Україна»
вул. Васильківська, 34,
офіс 204-г
03022, м. Київ
Тел. (+38) 044 498 39 02
info@gardena.ua

Uruguay

FELI SA
Entre Ríos 1083 CP 11800
Montevideo – Uruguay
Tel: (+598) 22 03 18 44
info@felisa.com.uy

Venezuela

Corporación Casa y Jardín C.A.
Av. Caroní, Edif. Trezmen, PB.
Colinas de Bello Monte.
1050 Caracas.
Tlf: (+58) 212 992 33 22
info@casayjardin.net.ve

19080-20.960.02/0818

© GARDENA
Manufacturing GmbH
D-89070 Ulm
http://www.gardena.com