

PowerMax Li-40/32 Art. 5033

DE Betriebsanleitung

Akku-Rasenmäher

EN Operator's manual

Battery Lawnmower

FR Mode d'emploi

Tondeuse sur batterie

NL Gebruiksaanwijzing

Accu-grasmaaier

SV Bruksanvisning

Accu-gräsklippare

DA Brugsanvisning

Accu-plæneklipper

FI Käyttöohje

Akkukäyttöinen ruohonleikkuri

NO Bruksanvisning

Batteridrevet gressklipper

IT Istruzioni per l'uso

Rasaerba a batteria

ES Instrucciones de empleo

Cortacésped de batería recargable

PT Manual de instruções

Máquina de cortar relva a bateria

PL Instrukcja obsługi

Akumulatorowe kosiarki do trawy

HU Használati utasítás

Akkumulátoros fűnyíró

CS Návod k obsluze

Akumulátorová sekačka na trávnik

SK Návod na obsluhu

Akumulátorová kosačka

EL Οδηγίες χρήσης

Χλοκοπτικό μπαταρίας

RU Инструкция по эксплуатации

Аккумуляторная газонокосилка

SL Navodilo za uporabo

Akumulatorska kosilnica

HR Upute za uporabu

Baterijska kosilica za travu

SR/ Uputstvo za rad
BS Baterijska kosilica za travu

UK Інструкція з експлуатації

Акумуляторна газонокосарка

RO Instrucțiuni de utilizare

Mașină de tuns iarbă

TR Kullanma Kılavuzu

Akülü çim biçme makinesi

BG Инструкция за експлоатация

Аккумуляторна косачка

SQ Manual përdorimi

Korrëse bari me bateri

ET Kasutusjuhend

Akuga muruniiduk

LT Eksploatavimo instrukcija

Akumuliatorinė vejamovė

LV Lietošanas instrukcija

Ar akumulatoru darbināms zāles plāvējs

<p>DE Produkthaftung Wir weisen ausdrücklich darauf hin, dass wir in Übereinstimmung mit dem Produkthaftungsgesetz nicht für Schäden haften, die durch unsere Produkte entstehen, wenn diese unsachgemäß und nicht durch einen von uns autorisierten Servicepartner repariert wurden oder wenn keine Original GARDENA Teile oder von uns zugelassene Teile verwendet wurden.</p>
<p>EN Product liability In accordance with the German Product Liability Act, we hereby expressly declare that we accept no liability for damage incurred from our products where said products have not been properly repaired by a GARDENA-approved service partner or where original GARDENA parts or parts authorised by GARDENA were not used.</p>
<p>FR Responsabilité Conformément à la loi relative à la responsabilité du fait des produits défectueux, nous déclarons expressément par la présente que nous déclinons toute responsabilité pour les dommages résultant de nos produits, si lesdits produits n'ont pas été correctement réparés par un partenaire d'entretien agréé GARDENA ou si des pièces d'origine GARDENA ou des pièces agréées GARDENA n'ont pas été utilisées.</p>
<p>NL Productaansprakelijkheid Conform de Duitse wet inzake productaansprakelijkheid verklaren wij hierbij uitdrukkelijk dat wij geen aansprakelijkheid aanvaarden voor schade ontstaan uit onze producten waarbij deze producten niet zijn gerepareerd door een GARDENA-erkende servicepartner of waarbij geen originele GARDENA-onderdelen of onderdelen die door GARDENA zijn goedgekeurd zijn gebruikt.</p>
<p>SV Produktansvar I enlighet med tyska produktansvarslagar förklarar vi härmed uttryckligen att vi inte åtar oss något ansvar för skador som orsakas av våra produkter där produkterna inte har genomgått korrekt reparation från en GARDENA-godkänd servicepartner eller där originaldelar från GARDENA eller delar godkända av GARDENA inte använts.</p>
<p>DA Produktansvar I overensstemmelse med den tyske produktansvarslov erklærer vi hermed udtrykkeligt, at vi ikke påtager os noget ansvar for skader på vores produkter, hvis de pågældende produkter ikke er blevet repareret korrekt af en GARDENA-godkendt servicepartner, eller hvor der ikke er brugt originale GARDENA-reservedele eller godkendte reservedele fra GARDENA.</p>
<p>FI Tuotevastuu Saksan tuotevastuulain mukaisesti emme ole vastuussa laitteiden vaurioista, jos korjauksia ei ole tehnyt GARDENA:n hyväksymä huoltoliike tai jos niiden synnä on muiden kuin alkuperäisten GARDENA-varaosien tai GARDENA:n hyväksymien varaosien käyttö.</p>
<p>IT Responsabilità del prodotto In conformità con la Legge tedesca sulla responsabilità del prodotto, con la presente dichiariamo espressamente che decliniamo qualsiasi responsabilità per danni causati dai nostri prodotti qualora non siano stati correttamente riparati presso un partner di assistenza approvato GARDENA o laddove non siano stati utilizzati ricambi originali o autorizzati GARDENA.</p>
<p>ES Responsabilidad sobre el producto De acuerdo con la Ley de responsabilidad sobre productos alemana, por la presente declaramos expresamente que no aceptamos ningún tipo de responsabilidad por los daños ocasionados por nuestros productos si dichos productos no han sido reparados por un socio de mantenimiento aprobado por GARDENA o si no se han utilizado piezas originales GARDENA o piezas autorizadas por GARDENA.</p>
<p>PT Responsabilidade pelo produto De acordo com a lei alemã de responsabilidade pelo produto, declaramos que não nos responsabilizamos por danos causados pelos nossos produtos, caso os tais produtos não tenham sido devidamente reparados por um parceiro de assistência GARDENA aprovado ou se não tiverem sido utilizadas peças GARDENA originais ou peças autorizadas pela GARDENA.</p>
<p>PL Odpowiedzialność za produkt Zgodnie z niemiecką ustawą o odpowiedzialności za produkt, niniejszym wyraźnie oświadczamy, że nie ponosimy żadnej odpowiedzialności za szkody poniesione na skutek użytkowania naszych produktów, w przypadku gdy naprawa tych produktów nie była odpowiednio przeprowadzana przez zatwierdzonego przez firmę GARDENA partnera serwisowego lub nie stosowano oryginalnych części GARDENA albo części autoryzowanych przez tę firmę.</p>
<p>HU Termékszavatosság A németországi termékszavatossági törvénnyel összhangban ezennel nyomatékosan kijelentjük, hogy nem vállalunk felelősséget a termékeinkben keletkezett olyan károkért, amelyek valamely GARDENA által jóváhagyott szervizpartner által nem megfelelően végzett javításból adódtak, vagy amely során nem eredeti GARDENA alkatrészeket vagy a GARDENA által jóváhagyott alkatrészeket használtak fel.</p>
<p>CS Odpovědnost za výrobek V souladu s německým zákonem o odpovědnosti za výrobek tímto výslovně prohlašujeme, že nepřijímáme žádnou odpovědnost za poškození vzniklá na našich výrobcích, kdy zmíněné výrobky nebyly řádně opraveny schváleným servisním partnerem GARDENA nebo kdy nebyly použity originální náhradní díly GARDENA nebo náhradní díly autorizované společností GARDENA.</p>
<p>SK Zodpovednosť za produkt V súlade s nemeckými právnymi predpismi upravujúcimi zodpovednosť za výrobok týmto výslovné prehlasujeme, že nenesieme žiadnu zodpovednosť za škody spôsobené našimi výrobkami, v prípade ktorých neboli náležité opravy vykonané servisným partnerom schváleným spoločnosťou GARDENA alebo neboli použité diely spoločnosti GARDENA alebo diely schválené spoločnosťou GARDENA.</p>
<p>EL Ευθύνη προϊόντος Σύμφωνα με τον γερμανικό νόμο περί Ευθύνης για τα Προϊόντα, με το παρόν δηλώνουμε ρητώς ότι δεν αποδεχόμαστε καμία ευθύνη για τυχόν ζημιές που προκύπτουν από τα προϊόντα μας εάν αυτά δεν έχουν επισκευαστεί σωστά από κάποιον εγκεκριμένο συνεργάτη επισκευών της GARDENA ή εάν δεν έχουν χρησιμοποιηθεί αυθεντικά εξαρτήματα GARDENA ή εξαρτήματα εγκεκριμένα από την GARDENA.</p>
<p>SL Odgovornost proizvajalca V skladu z nemškimi zakoni o odgovornosti za izdelke, izrecno izjavljajo, da ne sprejemamo nobene odgovornosti za škodo, ki jo povzročijo naši izdelki, če teh niso ustrezno popravili GARDENINI odobreni servisni partnerji ali pri tem niso bili uporabljeni originalni GARDENINI nadomestni deli ali GARDENINIMI homologiranimi nadomestnimi deli.</p>
<p>HR Pouzdanost proizvoda Sukladno njemačkom zakonu o pouzdanosti proizvoda, ovime izričito izjavljujemo kako ne prihvaćamo nikakvu odgovornost za oštećenja na našim proizvodima nastala uslijed neispravnog popravka od strane servisnog partnera kojeg odobrava GARDENA ili uslijed nekorištenja originalnih GARDENA dijelova ili dijelova koje odobrava GARDENA.</p>
<p>RO Răspunderea pentru produs În conformitate cu Legea germană privind răspunderea pentru produs, declarăm în mod expres prin prezentul document că nu acceptăm nicio răspundere pentru defecțiunile suferite de produsele noastre atunci când acestea nu au fost reparate în mod corect de un atelier de service partener, aprobat de GARDENA, sau când nu au fost utilizate piese GARDENA originale sau piese autorizate de GARDENA.</p>
<p>BG Отговорност за вреди, причинени от стоки Съгласно германския Закон за отговорността за вреди, причинени от стоки, с настоящото изрично декларираме, че не носим отговорност за щети, причинени от нашите продукти, ако те не са били правилно ремонтирани от одобрен от GARDENA сервиз или ако не са използвани оригинални части на GARDENA или части, одобрени от GARDENA.</p>
<p>ET Tootevastutus Vastavalt Saksamaa tootevastutusseadusele deklareerime käesolevaga selgesõnaliselt, et me ei kanna mingisugust vastutust meie toodetest tingitud kahjude eest, kui need tooted ei ole korrektselt parandatud GARDENA heakskiidetud hoolduspartneri poolt või kui parandamisel ei ole kasutatud GARDENA originaalosi või GARDENA volitatud osi.</p>
<p>LT Gaminio patikimumas Mes aiškiai pareiškiame, kad, atsižvelgiant į Vokietijos gaminių patikimumo įstatymą, nepriisiame atsakomybės dėl bet kokios žalos, patirtos dėl mūsų gaminių, jeigu jie buvo netinkamai taisomi arba jų dalys buvo pakeistos neoriginaliomis GARDENA dalimis ar nepatvirtintomis dalimis, arba jeigu remonto darbai buvo atliekami ne GARDENA techninės priežiūros centro specialistų.</p>
<p>LV Atbildība par produkcijas kvalitāti Saskaņā ar Vācijas likumu par atbildību par produkcijas kvalitāti ar šo mēs paziņojam, ka neuzņemamies atbildību par bojājumiem, kas radušies, lietojot mūsu izstrādājumus, kuru remontu nav veicis uzņēmuma GARDENA apstiprināts apkopes partneris vai kuru remontam netika izmantotas oriģinālās GARDENA detaļas vai detaļas, kuru lietošanu apstiprinājis uzņēmums GARDENA.</p>

A1

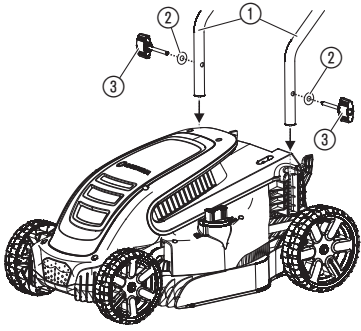

A2

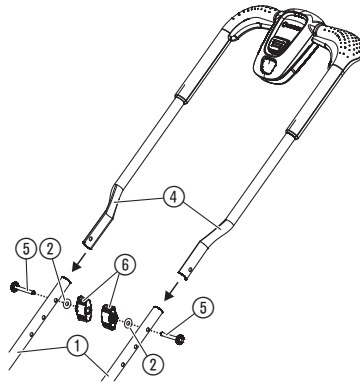

A3

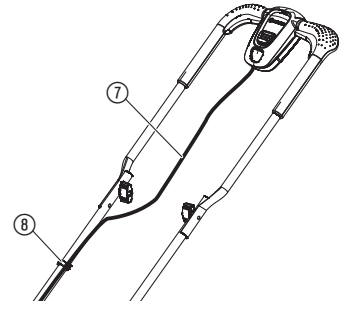

A4

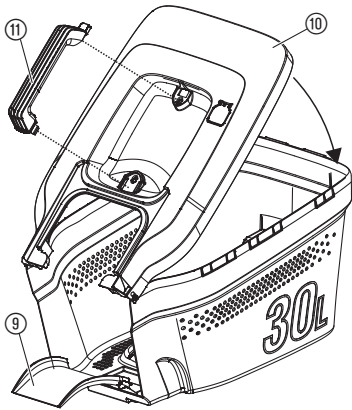

A5

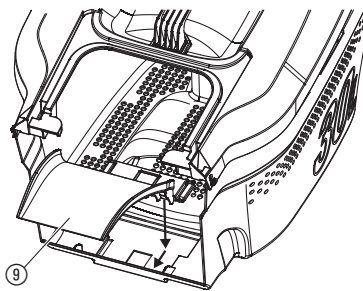

O1

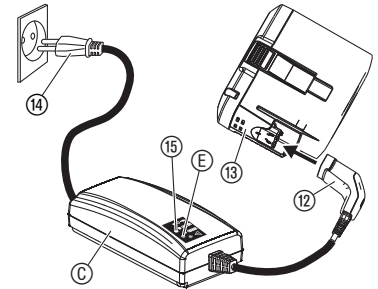

O2

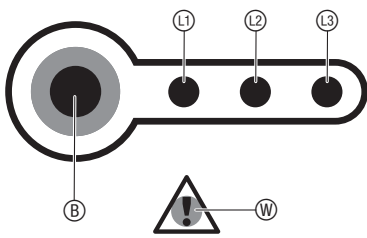

O3

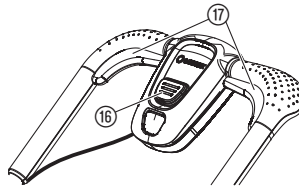

O5

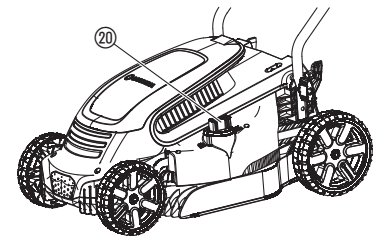

O4

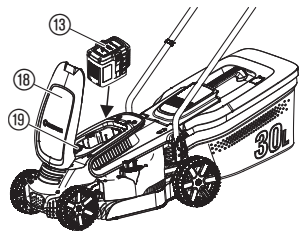

O6

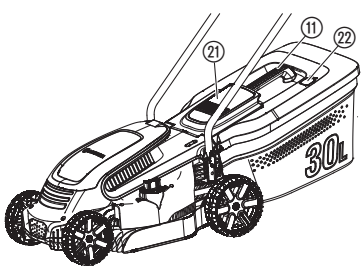

M1

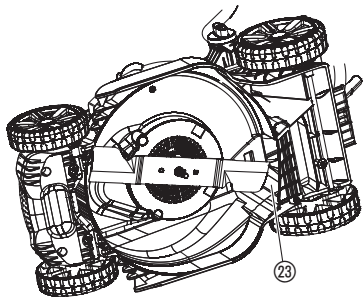

S1

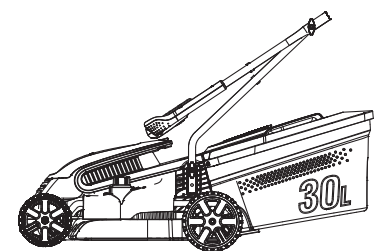

EN

Original instructions.



This product may be used under supervision, or if instruction regarding the safe use of the product has been provided and the resulting dangers have been understood, by children aged 8 and above, as well as by persons with physical, sensory or mental disabilities or a lack of experience and knowledge. Children must not be allowed to play with the product. Cleaning and user maintenance must not be per-

formed by children without supervision. The use of this product by young people under the age of 16 is not recommended.

Intended use:

The GARDENA Battery Lawnmower is used to cut lawn in private domestic gardens and allotments.

The product is not intended for long term use.

DANGER! Risk of injury! Do not use the product to cut bushes, hedges, shrubs, to cut off climbers or grass on roofs or balcony boxes, to chop up branches, twigs and to level irregularities in the soil. Do not use the product on a slope steeper than 20° maximum.

1. SAFETY

IMPORTANT!

Read the operator's manual carefully before use and keep for future reference.

Symbols on the product:

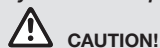

CAUTION!

If not used properly this product can be dangerous. The warnings and safety instructions must be followed to ensure reasonable safety and efficiency in using this product. The operator is responsible for following the warnings and instructions in this manual and on the product. Never use the product unless the guards provided by the manufacturer are in the correct position. Careless or incorrect use of this product can result in injury to the user or others. Read and understand the content of the operator's manual. Keep the manual for future reference.



Read operator's manual.



Keep other persons away.



Beware of sharp blades. Blades continue to rotate after the engine is switched off.

Remove safety key before you do maintenance or if the cable becomes damaged or cut.



Not valid for the battery mower.



Secure the working area before starting to work. Watch out for hidden cables.



Fire risk! Short-circuit!
Do not connect the contacts of the battery with metal components.



Do not let the product become wet with rain or other moisture.

General safety warnings

Electrical safety



DANGER! Electric shock!
Risk of injury due to electric shock.

→ The product must be supplied through a residual current device (RCD) having a rated residual operating current not exceeding 30 mA.



DANGER! Risk of injury!
Cut injury when the blade turns or the product starts accidentally.

→ Remove the safety key before you do maintenance or you replace parts. Thereby the removed safety key must be in the visual range.

Training

1. Read the instructions carefully. Be familiar with the controls and the correct use of the machine.
2. Never allow children or people unfamiliar with these instructions to use the machine. Local regulations can restrict the age of the operator.
3. Never operate the machine while people, especially children, or pets are nearby.
4. Keep in mind that the operator or user is responsible for accidents or hazards occurring to other people or their property.

Preparation

1. While operating the machine always wear substantial footwear and long trousers. Do not operate the machine when barefoot or wearing open sandals. Avoid wearing clothing that is loose fitting or that hanging cords or ties.

2. Thoroughly inspect the area where the machine is to be used and remove all objects which can be thrown by the machine.
3. Before using, always visually inspect to see that the blade, blade bolt and the blade assembly are not worn or damaged. Replace worn or damaged components in set to preserve balance. Replace damaged or unreadable labels.
4. Before use check the supply and extension cord for signs of damage or aging. If the cord becomes damaged during use, disconnect the cord from the supply immediately. **DO NOT TOUCH THE CORD BEFORE DISCONNECTING THE SUPPLY.** Do not use the machine if the cord is damaged or worn.

Operation

1. Operate the machine only in daylight or in good artificial light.
2. Avoid operating the machine in wet grass.
3. Always be sure of your footing on slopes.
4. Walk, never run.
5. Mow across the face of slopes, never up and down.
6. Exercise extreme caution when changing direction on slopes.
7. Do not mow excessively steep slopes.
8. Use extreme caution when reversing or pulling the machine towards you.
9. Stop the blade(s) if the machine has to be tilted for transportation when crossing surfaces other than grass, and when transporting the machine to and from area to be used.
10. Never operate the machine with defective guards or shields, or without safety devices, for example deflectors and/or grass collector, in place.
11. Switch on the motor carefully according to instructions and with feet well away from the blade(s).
12. Do not tilt the machine when switching on the motor, except if the machine has to be tilted for starting. In this case, do not tilt it more than absolutely necessary and lift only the part, which is away from the operator.
13. Do not start the machine when standing in front of the discharge opening.
14. Do not put hands or feet near or under rotating parts. Keep clear of the discharge opening at all times.
15. Do not transport the machine while the power source is running.
16. Stop the machine, and remove the disabling device. Make sure that all moving parts have come to a complete stop
 - whenever you leave the machine,
 - before clearing blockages or unclogging chute,
 - before checking, cleaning or working on the machine,
 - after striking a foreign object. Inspect the machine for damage and make repairs before restarting and operating the machine;

if the machine starts to vibrate abnormally (check immediately)

- inspect for damage,
- replace or repair any damaged parts,
- check for and tighten any loose parts.

Maintenance and storage

1. Keep all nuts, bolts, and screws tight to be sure the machine is in safe working condition.
2. Check the grass collector frequently for wear or deterioration.
3. On machines with multi blade, take care as rotating one blade can cause other blades rotate.
4. Be careful during adjustment of the machine to prevent entrapment of the fingers between moving blades and fixed parts of the machine.
5. Always allow the machine to cool down before storing.
6. When servicing the blades be aware that, even though the power source is switched off, the blades can still be moved.
7. Replace worn or damaged parts for safety. Use only genuine replacement parts and accessories.

Additional safety warnings

Battery safety



DANGER! Fire risk!

The battery to be charged must be placed on a non-flammable, heat resistant and non-conductive surface while charging.

Keep corrosive, flammable and easily combustible objects clear of the battery charger and the battery. Do not cover the battery charger and the battery while charging.

Disconnect the battery charger immediately in the event of smoke formation or fire.

Only use the original GARDENA Charger to charge the battery. The use of other battery chargers may damage the batteries irreparably and even cause a fire.

Only use original GARDENA batteries for the GARDENA battery product. Do not charge any third-party batteries. Risk of fire and explosion!

If you notice fire: Extinguish the flames with oxygen reducing materials.



DANGER! Risk of explosion!

Protect batteries from heat and fire. Do not leave on radiators or expose to strong sunshine for long periods.

Do not operate in explosive atmospheres, such as in the presence of flammable liquids, gases, or dust. Batteries may create sparks which could ignite the dust or fumes.

Check your replacement battery before each use. Visually check the battery before each use. A non-functioning battery must be disposed of correctly. Do not send by post. For further details, please contact your local disposal companies.

For risks of injury do not use the battery as a power source for other products. Only use the battery for the GARDENA product intended.

Only charge and use the battery in ambient temperatures between 0 °C and 40 °C. Allow battery to cool down after long periods of use.

Check the charging cable regularly for signs of damage or ageing (brittleness). Only use it in perfect condition.

Do not stow and transport the battery above 45 °C or in direct sunlight. Ideally, the battery should be stored below 25 °C so that self-discharge is low.

Do not expose the battery to rain or wet conditions. Water entering a battery will increase the risk of electric shock.

Keep battery in order (clean) especially air vents.

If usage of the battery is not planned for a certain time (winter period) reload the battery to avoid a deep discharge.

Do not store while still attached to a tool, this prevents misuse and accidents.

Do not store the battery in places where static electricity is present.

Electrical safety



DANGER! Cardiac arrest!

This product makes an electromagnetic field while it operates. This field may under some conditions interfere with active or passive medical implants. To decrease the risk of conditions that can possibly injure or kill, we recommend persons with medical implants to speak with their physician and the medical implant manufacturer before you operate the product.

Before use, examine the cable for signs of damage or ageing. If the cable is found to be defective, take the product to an Authorised Service Centre and have the cable replaced.

Do not use the product if the electric cables are damaged or worn.

Immediately disconnect from the mains if the charger cable is cut, or the insulation is damaged. Do not touch the electric cable until the cable has been disconnected. Do not repair a cut or damaged cable. Replace it with a new one.

Do not carry the product by the cable.

Do not pull on the cable to disconnect any of the plugs.

Use only on AC mains supply voltage shown on the product rating label.

Our products are double insulated to EN 60335. Do not connect an earth to any part of the product.

Check the working area for hidden cables.

Do not use for pond care or close to water.

Personal safety



DANGER! Risk of suffocation!

Small parts can be easily swallowed. There is also a risk that the polybag can suffocate toddlers. Keep toddlers away when you assemble the product.

Do not use in explosive atmosphere.

Never operate the product when you are tired, ill or under the influence of alcohol, drugs or medicine.

Do not overload the mower.

Use gloves, wear slip resistant shoes and wear eye protection.

Do not use under wet conditions.

Do not disassemble the product further than the delivery status.

Only start the mower with an upright standed handle.

Do not use the start levers alternately.

Use the handles carefully.

Safety Cut-Out

The engine is protected by a Safety Cut-Out which is activated when the blade becomes jammed or if the engine is overloaded. When this occurs, stop and disconnect the product from the mains. The Safety Cut-Out will only reset when you release the start/stop lever. Clear any obstruction and wait for a few minutes for the Safety Cut-Out to reset before you continue to use the product.

2. ASSEMBLY



DANGER! Risk of injury!

Cut injury when the blade turns or the product starts accidentally.

→ Wait for the blade to stop, remove the safety key and use gloves before you do assembly.

To connect the lower handle [Fig. A1]:

- Put the lower handle ① in the product.
Make sure that the handles are fully in place and the handle hole is inline with the threaded hole.

- Put the washer ② on the wing screw ③.
- Put the wing screw ③ in the threaded hole in the product.
- Tighten the wing screw ③.

To connect the upper handle [Fig. A2]:

- Put the upper handle ④ on the lower handle ①.
Make sure that the handles are fully in place and the handle holes are inline.
- Push the screw ⑤ through the hole.
- Put the washer ② and the wing nut ⑥ on the screw ⑤.
- Tighten the wing nut ⑥.

To fix the cable to the handle [Fig. A3]:

- Fix the cable ⑦ to the handle with the clip ⑧.
- Check that the cable ⑦ is not trapped between the lower and the upper handle.

To assemble the grass box [Fig. A4/A5]:

- Turn the cover ⑩ on the grass box.
Make sure that the cover ⑩ aligns to the grass box.
- Push the cover ⑩ on the grass box until the connections click.
Make sure that all connections are connected.
- Push the handle ⑪ into the cover ⑩ until it clicks.
- Push the chute ⑨ into the grass box and pull the chute ⑨ forward until it audibly engages.

3. OPERATION



DANGER! Risk of injury!

Cut injury when the blade turns or the product starts accidentally.

→ Wait for the blade to stop, remove the safety key and use gloves before you attach the battery or transport the product.

To charge the battery [Fig. O1]:



DANGER! Risk of injury!

Damage to the battery or the battery charger!

Overvoltage damages the battery and the battery charger.

→ Make sure that you use the correct mains voltage.

Before you use the battery the first time, the battery must be fully charged.

The lithium-ion battery can be charged in any state of charge and the charging process can be disconnected at any time without to damage the battery (no memory effect).

**For GARDENA Electric Lawnmower Art. 5033-20:
The GARDENA Battery BLi-40/100 Art. 9842 is in the scope of delivery.**

- Connect the mains cable ⑭ to the battery charger ⑮.
- Connect the mains cable ⑭ to a 230 V mains socket.
- Connect the charger cable ⑯ to the battery ⑰.

When the charging control lamp ⑱ at the charger flashes green once per second the battery is being charged.

When the charging control lamp ⑱ at the charger is lit green the battery is fully charged. For charging time, see 7. TECHNICAL DATA.

- Check the charge status regularly while you charge.
- When the battery is fully charged, disconnect the battery ⑰ from the battery charger ⑮.
- Disconnect the mains cable ⑭ from the mains.

Battery charging indicator [Fig. O2]:

Battery charging indicator during charging:

100 % charged	⑱, ⑲ and ⑲ lit
67 – 100 % charged	⑱ and ⑲ lit, ⑲ flashing
34 – 66 % charged	⑱ lit, ⑲ flashing
0 – 33 % charged	⑱ flashing

Battery charging indicator during operation:

Push the button ⑩ on the battery.

67 – 100 % charged	⑪, ⑫ and ⑬ lit
34 – 66 % charged	⑪ and ⑫ lit
11 – 33 % charged	⑪ lit
0 – 10 % charged	⑪ flashing

To start the mower [Fig. O3/O4]:

 **DANGER! Risk of injury!**
Risk of injury if the product does not stop when you release the start lever.
 → Do not bypass the safety devices or switches. For example do not attach the start lever ⑰ to the handle.

To start:

The product is fitted with a two-handed safety device (start lever ⑰ with safety interlock ⑱) to prevent the product from being turned on by accident.

There are two start levers ⑰ fitted. Either one have to be used to start.

1. Open the lid ⑮.
2. Put the battery ⑩ into the product.
3. Put the safety key ⑲ into the product and turn to position 1.
4. Push the safety interlock ⑱ with one hand and pull the start lever ⑰ with the other hand.
5. Release the safety interlock ⑱.
The product will start.

To stop:

1. Release the start lever ⑰.
2. Turn the safety key ⑲ to position 0 and remove it.

To adjust the cutting height [Fig. O5]:

The cutting height can be adjusted from 2 to 6 cm in 12 positions.

1. Push and turn the adjust wheel ⑳ clockwise to lower the cutting height.
2. Push and turn the adjust wheel ⑳ counterclockwise to increase the cutting height.

To use the mower with the grass box [Fig. O6]:

 **DANGER! Risk of injury!**
Cut injury when the blade turns or the product starts accidentally.
 → Wait for the blade to stop, remove the safety key and use gloves before you open the protective flap ㉑.
 → Do not put your hands in the discharge opening.

1. Lift the protective flap ㉑.
2. Put the grass box into the product by the handle ㉒.
3. Make sure that the grass box is securely connected.
4. Start the product.
The level indicator ㉓ opens the lid while you do mowing.
When the level indicator ㉓ closes the lid, the grass box is filled.
5. Stop the product.
6. Lift the protective flap ㉑.
7. Remove the grass box of the product by the handle ㉒.
8. Empty the grass box.

Tips to use the mower:

If grass residue is left in the discharge opening, pull the mower backwards about 1 m so that the grass residue can drop out downwards.

To produce a well-maintained lawn, we recommend to cut the lawn regularly once a week if possible. The lawn becomes denser if you cut it frequently.

After relatively long cutting intervals (holiday lawn), first of all cut in one direction with the highest cutting height and then cut in the crosswise direction with the required cutting height.

If possible, only cut the grass when it is dry, if the grass is damp, the cutting pattern will be uneven.

Cutting performance and battery charge:

The lawn area which can be cut on each battery charge depends on several factors such as moisture, grass density and cutting height. In order to ensure an optimal use of space, do not turn the mower on

and off too frequently as this severely reduces the battery running time. The cutting performance for each battery charge can be ideally utilised by increasing the cutting height and frequent mowing.

4. MAINTENANCE

 **DANGER! Risk of injury!**
Cut injury when the blade turns or the product starts accidentally.
 → Wait for the blade to stop, remove the safety key and use gloves before you do maintenance.

To clean the product:

 **DANGER! Electric shock!**
Risk of injury and risk of damage to the product.
 → Do not clean the product with water or with a water jet (in particular high-pressure water jet).

To clean the underside of the product [Fig. M1]:

The underside is easiest to clean after you mowed.

Use gloves.

1. Lay the product on its side carefully.
2. Clean the underside, the blade and the airflow slots ㉔ with a brush (do not use sharp objects).

To clean the overside of the product and the grass box:

Do not clean with chemicals including petrol or solvents. Some can destroy critical plastic parts.

1. Clean the overside with a damp cloth.
2. Clean the airflow slots and the grass box with a soft brush (do not use sharp objects).

To clean the battery and the battery charger:

Make sure that the surface and the contacts of the battery and the battery charger always are clean and dry before you connect the battery charger.

Do not use running water.

→ Clean the contacts and the plastic parts with a soft and dry cloth.

5. STORAGE

To put into storage [Fig. S1]:

The product must be stored away from children.

1. Turn the safety key to position 0 and remove it.
2. Remove the battery.
3. Charge the battery.
4. Clean the product, the battery and the battery charger (see 4. MAINTENANCE).
5. To save space, release the wing nuts of the handles until the joints can be folded together easily.
Make sure that the cable is stowed correctly to prevent damage.
6. Stowe the product, the battery and the charger in a dry, enclosed and secure place and in a frost-free place before the first frost arrives.

**Disposal:**

(in accordance with RL2012/19/EC)

The product must not be disposed of to normal household waste. It must be disposed of in line with local environmental regulations.

**IMPORTANT!**

→ Dispose of the product through or via your municipal recycling collection centre.

Disposal of the battery:

The GARDENA battery contains lithium-ion cells that should not be disposed of with normal household waste at the end of its life.

IMPORTANT!

→ Dispose of the batteries through or via your municipal recycling collection centre.

1. Discharge the lithium-ion cells completely (contact the GARDENA Service).
2. Protect the contacts on the lithium-ion cells against short circuits.
3. Dispose of the lithium-ion cells properly.

6. TROUBLESHOOTING



DANGER! Risk of injury!

Cut injury when the blade turns or the product starts accidentally.

→ Wait for the blade to stop, remove the safety key and use gloves before you do troubleshooting.

To replace the blade:



DANGER! Risk of injury!

Cut injury when the blade turns and it is damaged, bent, out of balance or has chipped edges.

→ Do not use the product when the blade is damaged, bent, out of balance or has chipped edges.

→ Do not regrind the blade.

The GARDENA spare parts are available from your GARDENA dealer or from the GARDENA service.

Only use an original GARDENA blade:

- **GARDENA replacement blade Art. 4100 [5822490-01].**

→ Let the blade replace by the GARDENA Service or a specialist dealer authorised by GARDENA .

Problem	Possible Cause	Remedy
Engine does not start	Extension cable is disconnected or damaged.	→ Connect the extension cable or if necessary replace it.
	Blade is blocked.	→ Remove the obstacle.
Engine is jammed and makes a noise	Blade is blocked.	→ Remove the obstacle.
	Cutting height is too low.	→ Raise the cutting height.
Loud noises, the mower is rattling	Screws on engine, its fixing or on the mower housing are loose.	→ Have screws tightened by an authorised specialist dealer or the GARDENA Service.
Product runs unevenly or vibrates strongly	Blade is damaged or the blade mounting is released.	→ Have blade tightened or replaced by an authorised specialist dealer or the GARDENA Service.
	Blade is very dirty.	→ Clean the mower (see 4. MAINTENANCE). If this does not rectify the problem, contact the GARDENA Service.
Lawn is not cleanly cut	Blade is blunt or damaged.	→ Have blade replaced by the GARDENA Service.
	Cutting height is too low.	→ Raise the cutting height.
Error-LED [Ⓜ] on the battery is flashing.	Over voltage.	→ Remove the battery and check that the mains voltage is correct.
	Under voltage.	→ Charge the battery.
	Battery temperature is out of range.	→ Use the battery in surroundings where temperatures are between 0 °C and 40 °C.
Error-LED [Ⓜ] on the battery lit	Battery error/battery defective.	→ Contact the GARDENA service.
Charging control lamp [Ⓜ] does not light up	Battery charger or charging cable are not connected correctly.	→ Connect the battery charger and charging cable correctly.
Charging control lamp [Ⓜ] is flashing rapidly (4 times per second)	Battery temperature is out of range.	→ Use the battery in surroundings where temperatures are between 0 °C and 40 °C.
Error-LED [Ⓜ] on the charger is flashing	Battery error.	→ Remove the battery and check that you use an original GARDENA battery.
Error-LED [Ⓜ] on the charger lit	Temperature inside the charger is too high.	→ Contact the GARDENA service.



NOTE: For any other malfunctions please contact the GARDENA service department. Repairs must only be done by GARDENA service departments or specialist dealers approved by GARDENA.

7. TECHNICAL DATA

Battery Lawnmower	Unit	Value (Art. 5033)
Speed of rotation cutting blade	R/min.	3,300
Cutting width	cm	32
Cutting height adjustment (12 positions)	cm	2 to 6
Volume of grass box	l	30
Weight	kg	8.4
Sound pressure level $L_{PA}^{1)}$ Uncertainty k_{PA}	dB (A)	73 3
Sound power level $L_{WA}^{2)}$: measured/guaranteed Uncertainty k_{WA}	dB (A)	86 / 86 0.59
Hand/arm vibration $a_{vhw}^{1)}$ Uncertainty k_a	m/s^2	1.64 1.5

System Battery / smart Battery	Unit	Value (Art. 9842/19090)	Value (Art. 9843/19091)
Lawn area which can be cut per battery charge • from 60 mm to 40 mm • from 80 mm to 40 mm	m^2 (approx.)	280 200	450 350
Battery voltage	V	max. 40 (The maximum initial no-load voltage of the battery is 40 V, the nominal voltage is 36 V)	max. 40 (The maximum initial no-load voltage of the battery is 40 V, the nominal voltage is 36 V)
Battery capacity	Ah	2.6	4.2
Battery charging time approx. 80 %/100 %	min.	65 / 90	105 / 140

Battery Charger	Unit	Value (Art. 9845)
Rated Power	W	100
Mains voltage	V	230
Mains frequency	Hz	50
Battery charging time for Art. 9842/19090 approx. 80 %/100 %	min.	65 / 90
Battery charging time for Art. 9843/19091 approx. 80 %/100 %	min.	105 / 140

Measuring process complying with: ¹⁾ EN 60335-2-77; ²⁾ RL 2000/14/EC



NOTE: The stated vibration emission value has been measured according to a standardized test procedure and can be used for comparison of one electric power tool with another. It can also be used for preliminary evaluation of exposure. The vibration emission value can vary during actual use of the electric power tool.

8. ACCESSORIES

GARDENA Replacement Battery BLi-40/100 / BLi-40/160	Battery for additional duration or for replacement.	Art. 9842/9843
GARDENA smart Battery BLi-40/100 / BLi-40/160	smart Battery for the smart System.	Art. 19090/19091
GARDENA smart Battery BLi-40/100 Set / BLi-40/160 Set	smart Battery with smart Gateway for the smart System.	Art. 19110/19111
GARDENA Battery Charger QC40	Battery Charger to charge the GARDENA Batteries and smart Batteries.	Art. 9845
GARDENA Replacement Blade	As replacement for blunt blade.	Art. 4100 [5822490-01]

9. SERVICE / WARRANTY

Service:

Please contact the address on the back page.

Warranty:

In the event of a warranty claim, no charge is levied to you for the services provided.

GARDENA Manufacturing GmbH offers a two-year warranty (effective as of the date of purchase) for this product. This warranty includes all significant defects of the product that can be proved to be material or manufacturing faults. The warranty will be fulfilled by the supply of a working replacement product provided that the following conditions are met:

- The product was used for its intended purpose as per the recommendations in the operating instructions.
- Neither the purchaser nor a third party has attempted to repair the product.

This manufacturer's warranty does not affect warranty entitlements against the dealer/retailer.

For troubleshooting, please contact our Service department (contact details see back page). It is not permitted to send a product to us without prior agreement.

Consumables:

The blade is a consumable and is not included in the warranty.

Deutschland / Germany

GARDENA
Manufacturing GmbH
Central Service
Hans-Lorenser-Straße 40
D-89079 Ulm
Produktfragen:
(+49) 731 490-123
Reparaturen:
(+49) 731 490-290
service@gardena.com

Albania

COBALT Sh.p.k.
Rr. Siri Kodra
1000 Tirana

Argentina

Husqvarna Argentina S.A.
Av.del Libertador 5954 –
Piso 11 – Torre B
(C1428ARP) Buenos Aires
Phone: (+54) 11 5194 5000
info.gardena@
ar.husqvarna.com

Armenia

Garden Land Ltd.
61 Tigran Mets
0005 Yerevan

Australia

Husqvarna Australia Pty. Ltd.
Locked Bag 5
Central Coast BC
NSW 2252
Phone: (+61) (0) 2 4352 7400
customer.service@
husqvarna.com.au

Austria / Österreich

Husqvarna Austria GmbH
Industriezeile 36
4010 Linz
Tel.: (+43) 732 77 01 01-485
service.gardena@
husqvarnagroup.com

Azerbaijan

Firm Progress
a. Aliyev Str. 26A
1052 Bakı

Belgium

Husqvarna België nv/sa
Gardena Division
Rue Eglise Van Ophem 111
1180 Uccle / Ukkel
Tel.: (+32) 2 720 92 12
info@gardena.be

Bosnia / Herzegovina

SILK TRADE d.o.o.
Industrijska zona Bukva bb
74260 Tešanj

Brazil

Husqvarna do Brasil Ltda
Av. Francisco Matarazzo,
1400 – 19º andar
São Paulo – SP
CEP: 05001-903
Tel: 0800-112252
marketing.br.husqvarna@
husqvarna.com.br

Bulgaria

AGROLAND България АД
бул. 8 Декември, №13
Офис 5
1700 Студентски град
София
Тел.: (+359) 2466 69 10
info@agroland.eu

Canada / USA

GARDENA Canada Ltd.
100 Summerlea Road
Brampton, Ontario L6T 4X3
Phone: (+1) 905 792 9330
info@gardenacanada.com

Chile

Maquinarias Agroforestales
Ltda. (Maga Ltda.)
Santiago, Chile
Avda. Chesterton
8355 comuna Las Condes
Phone: (+56) 2 202 4417
Dalton@maga.cl
Zipcode: 7560330

China

Husqvarna (Shanghai)
Management Co., Ltd.
富世华 (上海) 管理有限公司
3F, Benq Square B,
No207, Song Hong Rd.,
Chang Ning District,
Shanghai, PRC. 200335
上海市长宁区淞虹路207号明
基广场B座3楼, 邮编: 200335

Colombia

Husqvarna Colombia S.A.
Calle 18 No. 68 D-31, zona
Industrial de Montevideo
Bogotá, Cundinamarca
Tel. 571 2922700 ext. 105
jairo.salazar@
husqvarna.com.co

Costa Rica

Compania Exim
Euroiberoamericana S.A.
Los Colegios, Moravia,
200 metros al Sur del Colegio
Saint Francis – San José
Phone: (+506) 297 68 83
exim_euro@racsa.co.cr

Croatia

Husqvarna Austria GmbH
Industriezeile 36
4010 Linz
Tel.: (+43) 732 77 01 01-485
service.gardena@
husqvarnagroup.com

Cyprus

Med Marketing
17 Digeni Akrita Ave
P.O. Box 27017
1641 Nicosia

Czech Republic

Husqvarna Česko s.r.o.
Türkova 2319/5b
149 00 Praha 4 – Chodov
Bezplatná infolinka:
800 100 425
servis@cz.husqvarna.com

Denmark

GARDENA DANMARK
Lejrvej 19, st.
3500 Værløse
Tlf.: (+45) 7026 4770
husqvarna@husqvarna.dk
www.gardena.com/dk

Dominican Republic

BOSQUESA, S.R.L
Carretera Santiago Licey
Km. 5 ½
Esquina Copal II.
Santiago
Dominican Republic
Phone: (+809) 736-0333
joserbosquesa@claro.net.do

Ecuador

Husqvarna Ecuador S.A.
Arupos E1-181 y 10 de
Agosto Quito, Pichincha
Tel. (+593) 22800739
francisco.jacome@
husqvarna.com.ec

Estonia

Husqvarna Eesti OÜ
Valdeku 132
EE-11216 Tallinn
info@gardena.ee

Finland

Oy Husqvarna Ab
Gardena Division
Lautatarhankatu 8 B/PL 3
00581 HELSINKI
www.gardena.fi

France

Husqvarna France
9/11 Allée des pierres mayettes
92635 Gennevilliers Cedex
France
http://www.gardena.com/fr
N° AZUR: 0 810 00 78 23
(Prix d'un appel local)

Georgia

Transporter LLC
8/57 Beliashvili street
0159 Tbilisi, Georgia
Phone: (+995) 322 14 71 71

Great Britain

Husqvarna UK Ltd
Preston Road
Aycliffe Industrial Park
Newton Aycliffe
County Durham
DL5 6UP
info.gardena@
husqvarna.co.uk

Greece

Π. ΠΑΠΑΔΟΠΟΥΛΟΣ ΑΕΒΕ
Λεωφ. Αθηνών 92
Αθήνα
T.K.104 42
Ελλάδα
Τηλ. (+30) 210 5193 100
info@papadopoulos.com.gr

Hungary

Husqvarna Magyarország Kft.
Ezred u. 1-3
1044 Budapest
Telefon: (+36) 1 251-4161
vevoszolgalat.husqvarna@
husqvarna.hu

Iceland

Ö. Johnson & Kaaber
Tunguhalsi 1
110 Reykjavik
ooj@ojk.is

Ireland

Husqvarna UK Ltd
Preston Road
Aycliffe Industrial Park
Newton Aycliffe
County Durham
DL5 6UP
info.gardena@
husqvarna.co.uk

Italy

Husqvarna Italia S.p.A.
Via Santa Vecchia 15
23868 VALMADRERA (LC)
Phone: (+39) 0341.203.111
assistenza.italia@
it.husqvarna.com

Japan

KAUICHI Co. Ltd.
Sumitomo Realty &
Development Kojimachi
BLDG., 8F
5-1 Nibanncyo
Chiyoda-ku
Tokyo 102-0084
Phone: (+81) 33 264 4721
m_ishihara@kaku-ichi.co.jp

Kazakhstan

LAMED Ltd.
155/1, Tazhibayevoy Str.
050060 Almaty
IP Schmidt
Abayavenue 3B
110 005 Kostanay

Korea

Kyung Jin Trading CO.,LTD.
107-4, SunDuk Bld.,
YangJae-dong,
Seocho-gu,
Seoul, (zipcode: 137-891)
Phone: (+82) (0)2 574-6300

Kyrgyzstan

Alye Maki
av. Moladaya Guardir J 3
720014
Bishkek

Latvia

Husqvarna Latvija SIA
Ulbrokas 19A
LV-1021 Riga
info@gardena.lv

Lithuania

UAB Husqvarna Lietuva
Ateities pl. 77C
LT-52104 Kaunas
info@gardena.lt

Luxembourg

Magasins Jules Neuberg
39, rue Jacques Stas
Luxembourg-Gasperich 2549
Case Postale No. 12
Luxembourg 2010
Phone: (+352) 40 14 01
api@neuberg.lu

Mexico

AFOSA
Av. Lopez Mateos Sur # 5019
Col. La Calma 45070
Zapopan, Jalisco
Mexico
Phone: (+52) 33 3818-3434
icornejo@afosa.com.mx

Moldova

Convel S.R.L.
290A Muncesti Str.
2002 Chisinau

Netherlands

Husqvarna Nederland B.V.
GARDENA Division
Postbus 50131
1305 AC ALMERE
Phone: (+31) 36 521 00 10
info@gardena.nl

Neth. Antilles

Jonka Enterprises N.V.
Sta. Rosa Weg 196
P.O. Box 8200
Curaçao
Phone: (+599) 9 767 66 55
pgm@jonka.com

New Zealand

Husqvarna New Zealand Ltd.
PO Box 76-437
Manukau City 2241
Phone: (+64) (0) 9 9202410
support.nz@husqvarna.co.nz

Norway

Husqvarna Norge AS
Gardena Division
Trøskenveien 36
1708 Sarpsborg
info@gardena.no

Peru

Husqvarna Perú S.A.
Jr. Ramón Cárcamo 710
Lima 1
Tel: (+51) 1 3320400 ext. 416
juan.remuzgo@
husqvarna.com

Poland

Husqvarna
Poland Spółka z o.o.
ul. Wysockiego 15 b
03-371 Warszawa
Phone: (+48) 22 330 96 00
gardena@husqvarna.com.pl

Portugal

Husqvarna Portugal, SA
Lagoa - Albarraque
2635 - 595 Rio de Mouro
Tel.: (+351) 21 922 85 30
Fax : (+351) 21 922 85 36
info@gardena.pt

Romania

Madex International Srl
Soseaua Odaii 117-123,
RO 013603 București, S 1
Phone: (+40) 21 352.76.03
madex@ines.ro

Russia / Россия

ООО „Хускварна“
141400, Московская обл.,
г. Химки,
улица Ленинградская,
владение 39, стр.6
Бизнес Центр
„Химки Бизнес Парк“,
помещение ОВ02_04
http://www.gardena.ru

Serbia

Domel d.o.o.
Autoput za Novi Sad bb
11273 Belgrade
Phone: (+381) 1 18 48 88 12
miroslav.jejina@domel.rs

Singapore

Hy-Ray PRIVATE LIMITED
40 Jalan Pemimpin
#02-08 Tat Ann Building
Singapore 577185
Phone: (+65) 6253 2277
shiyiyng@hyray.com.sg

Slovak Republic

Husqvarna Česko s.r.o.
Türkova 2319/5b
149 00 Praha 4 – Chodov
Bezplatná infolinka:
800 154 044
servis@sk.husqvarna.com

Slovenia

Husqvarna Austria GmbH
Industriezeile 36
4010 Linz
Tel.: (+43) 732 77 01 01-485
service.gardena@
husqvarnagroup.com

South Africa

Husqvarna
South Africa (Pty) Ltd
Postnet Suite 250
Private Bag X6,
Cascades, 3202
South Africa
Phone: (+27) 33 846 9700
info@gardena.co.za

Spain

Husqvarna España S.A.
Calle de Rivas nº 10
28052 Madrid
Phone: (+34) 91 708 05 00
atencioncliente@gardena.es

Suriname

Agrofix n.v.
Verlengde Hogestraat #22
Phone: (+597) 472426
agrofix@sr.net
Pobox : 2006
Paramaribo
Suriname – South America

Sweden

Husqvarna AB
Gardena Division
S-561 82 Huskvarna
gardenaorder@husqvarna.se

Switzerland / Schweiz

Husqvarna Schweiz AG
Consumer Products
Industriestrasse 10
5506 Mägenwil
Phone: (+41) (0) 62 887 37 90
info@gardena.ch

Turkey

Dost Bahçe Diş Ticaret
Mümessilik A.Ş
Yunus Mah. Adil Sok. No:3
Ic Kapi No: 1 Kartal
34873 Istanbul
Phone: (+90) 216 38 93 939
info@dostbahce.com.tr

Ukraine / Україна

ТОВ «Хускварна Україна»
вул. Васильківська, 34,
офіс 204-г
03022, м. Київ
Тел. (+38) 044 498 39 02
info@gardena.ua

Uruguay

FELI SA
Entre Ríos 1083 CP 11800
Montevideo – Uruguay
Tel: (+598) 22 03 18 44
info@felisa.com.uy

Venezuela

Corporación Casa y Jardín C.A.
Av. Caroní, Edif. Trezmen, PB.
Colinas de Bello Monte.
1050 Caracas.
Tlf: (+58) 212 992 33 22
info@casayjardin.net.ve

5033-20.960.03/0518

© GARDENA
Manufacturing GmbH
D-89070 Ulm
http://www.gardena.com