

THS Li-18/42

Art. 8881

DE Betriebsanleitung

Accu-Teleskop-Heckenschere

EN Operator's manual

Telescopic Accu Hedge Trimmer

FR Mode d'emploi

Taille-haies télescopique sur accu

NL Gebruiksaanwijzing

Telescopische accu-heggenschaar

SV Bruksanvisning

Accu Teleskophäcksax

DA Brugsanvisning

Akku-teleskop-hækkeklipper

FI Käyttöohje

 Teleskooppivarrellinen
akkupensasleikkuri

NO Bruksanvisning

Batteri-teleskop-hekksaks

IT Istruzioni per l'uso

Tagliasiepi telescopica a batteria

ES Instrucciones de empleo

Recortasetos telescópico con Accu

PT Manual de instruções

Corta-sebes telescópico accu

PL Instrukcja obsługi

 Akumulatorowe nożyce do żywopłotu
z trzonkiem teleskopowym

HU Használati utasítás

 Akkumulátoros-teleszkópos
sövénynyíró

CS Návod k obsluze

 Akumulátorové teleskopické nůžky
na živý plot

SK Návod na obsluhu

Akumulátorové nožnice na živý plot

EL Οδηγίες χρήσης

 Τηλεσκοπικό μπόρντουροψάλιδο
μπαταρίας

RU Инструкция по эксплуатации

 Аккумуляторные телескопические
ножницы для живых изгородей

SL Navodilo za uporabo

 Akumulatorske teleskopske škarje za živo
mejo

HR Upute za uporabu

 Teleskopske škare za živicu
s akumulatorom

SR/ Uputstvo za rad
BS Teleskopske baterijske makaze za živicu

UK Інструкція з експлуатації

 Акумуляторний телескопічний
садовий секатор

RO Instrucțiuni de utilizare

 Trimmer telescopic cu acumulator pentru
gard viu

TR Kullanma Kılavuzu

Akülü teleskopik çit budayıcı

BG Инструкция за експлоатация

 Аккумуляторна телескопична ножица
за жив плет

SQ Manual përdorimi

Gërshërë gardhesh teleskopike me bateri

ET Kasutusjuhend

Aku ja teleskoopvarrega hekikäärid

LT Eksploatavimo instrukcija

 Akumuliatorinės teleskopinės gyvatvorių
žirklės

LV Lietošanas instrukcija

 Teleskopiskās dzīvžogu šķēres ar
akumulatoru

<p>DE Produkthaftung Wir weisen ausdrücklich darauf hin, dass wir in Übereinstimmung mit dem Produkthaftungsgesetz nicht für Schäden haften, die durch unsere Produkte entstehen, wenn diese unsachgemäß und nicht durch einen von uns autorisierten Servicepartner repariert wurden oder wenn keine Original GARDENA Teile oder von uns zugelassene Teile verwendet wurden.</p>
<p>EN Product liability In accordance with the German Product Liability Act, we hereby expressly declare that we accept no liability for damage incurred from our products where said products have not been properly repaired by a GARDENA-approved service partner or where original GARDENA parts or parts authorised by GARDENA were not used.</p>
<p>FR Responsabilité Conformément à la loi relative à la responsabilité du fait des produits défectueux, nous déclarons expressément par la présente que nous déclinons toute responsabilité pour les dommages résultant de nos produits, si lesdits produits n'ont pas été correctement réparés par un partenaire d'entretien agréé GARDENA ou si des pièces d'origine GARDENA ou des pièces agréées GARDENA n'ont pas été utilisées.</p>
<p>NL Productaansprakelijkheid Conform de Duitse wet inzake productaansprakelijkheid verklaren wij hierbij uitdrukkelijk dat wij geen aansprakelijkheid aanvaarden voor schade ontstaan uit onze producten waarbij deze producten niet zijn gerepareerd door een GARDENA-erkende servicepartner of waarbij geen originele GARDENA-onderdelen of onderdelen die door GARDENA zijn goedgekeurd zijn gebruikt.</p>
<p>SV Produktansvar I enlighet med tyska produktansvarslagar förklarar vi härmed uttryckligen att vi inte åtar oss något ansvar för skador som orsakas av våra produkter där produkterna inte har genomgått korrekt reparation från en GARDENA-godkänd servicepartner eller där originaldelar från GARDENA eller delar godkända av GARDENA inte använts.</p>
<p>DA Produktansvar I overensstemmelse med den tyske produktansvarslov erklærer vi hermed udtrykkeligt, at vi ikke påtager os noget ansvar for skader på vores produkter, hvis de pågældende produkter ikke er blevet repareret korrekt af en GARDENA-godkendt servicepartner, eller hvor der ikke er brugt originale GARDENA-reservedele eller godkendte reservedele fra GARDENA.</p>
<p>FI Tuotevastuu Saksan tuotevastuulain mukaisesti emme ole vastuussa laitteiden vaurioista, jos korjauksia ei ole tehnyt GARDENA:n hyväksymä huoltoliike tai jos niiden syynä on muiden kuin alkuperäisten GARDENA-varaosien tai GARDENA:n hyväksymien varaosien käyttö.</p>
<p>IT Responsabilità del prodotto In conformità con la Legge tedesca sulla responsabilità del prodotto, con la presente dichiariamo espressamente che decliniamo qualsiasi responsabilità per danni causati dai nostri prodotti qualora non siano stati correttamente riparati presso un partner di assistenza approvato GARDENA o laddove non siano stati utilizzati ricambi originali o autorizzati GARDENA.</p>
<p>ES Responsabilidad sobre el producto De acuerdo con la Ley de responsabilidad sobre productos alemana, por la presente declaramos expresamente que no aceptamos ningún tipo de responsabilidad por los daños ocasionados por nuestros productos si dichos productos no han sido reparados por un socio de mantenimiento aprobado por GARDENA o si no se han utilizado piezas originales GARDENA o piezas autorizadas por GARDENA.</p>
<p>PT Responsabilidade pelo produto De acordo com a lei alemã de responsabilidade pelo produto, declaramos que não nos responsabilizamos por danos causados pelos nossos produtos, caso os tais produtos não tenham sido devidamente reparados por um parceiro de assistência GARDENA aprovado ou se não tiverem sido utilizadas peças GARDENA originais ou peças autorizadas pela GARDENA.</p>
<p>PL Odpowiedzialność za produkt Zgodnie z niemiecką ustawą o odpowiedzialności za produkt, niniejszym wyraźnie oświadczamy, że nie ponosimy żadnej odpowiedzialności za szkody poniesione na skutek użytkowania naszych produktów, w przypadku gdy naprawa tych produktów nie była odpowiednio przeprowadzana przez zatwierdzonego przez firmę GARDENA partnera serwisowego lub nie stosowano oryginalnych części GARDENA albo części autoryzowanych przez tę firmę.</p>
<p>HU Termékszavatosság A németországi termékszavatossági törvénnyel összhangban ezennel nyomatékosan kijelentjük, hogy nem vállalunk felelősséget a termékeinkben keletkezett olyan károkért, amelyek valamely GARDENA által jóváhagyott szervizpartner által nem megfelelően végzett javításból adódtak, vagy amely során nem eredeti GARDENA alkatrészeket vagy a GARDENA által jóváhagyott alkatrészeket használtak fel.</p>
<p>CS Odpovědnost za výrobek V souladu s německým zákonem o odpovědnosti za výrobek tímto výslovně prohlašujeme, že nepřijímáme žádnou odpovědnost za poškození vzniklá na našich výrobcích, kdy zmíněné výrobky nebyly řádně opraveny schváleným servisním partnerem GARDENA nebo kdy nebyly použity originální náhradní díly GARDENA nebo náhradní díly autorizované společností GARDENA.</p>
<p>SK Zodpovednosť za produkt V súlade s nemeckými právnymi predpismi upravujúcimi zodpovednosť za výrobok týmto výslovné prehlasujeme, že nenesieme žiadnu zodpovednosť za škody spôsobené našimi výrobkami, v prípade ktorých neboli náležité opravy vykonané servisným partnerom schváleným spoločnosťou GARDENA alebo neboli použité diely spoločnosti GARDENA alebo diely schválené spoločnosťou GARDENA.</p>
<p>EL Ευθύνη προϊόντος Σύμφωνα με τον γερμανικό νόμο περί Ευθύνης για τα Προϊόντα, με το παρόν δηλώνουμε ρητώς ότι δεν αποδεχόμαστε καμία ευθύνη για τυχόν ζημιές που προκύπτουν από τα προϊόντα μας εάν αυτά δεν έχουν επισκευαστεί σωστά από κάποιον εγκεκριμένο συνεργάτη επισκευών της GARDENA ή εάν δεν έχουν χρησιμοποιηθεί αυθεντικά εξαρτήματα GARDENA ή εξαρτήματα εγκεκριμένα από την GARDENA.</p>
<p>SL Odgovornost proizvajalca V skladu z nemškimi zakoni o odgovornosti za izdelke, izrecno izjavljajo, da ne sprejemamo nobene odgovornosti za škodo, ki jo povzročijo naši izdelki, če teh niso ustrezno popravili GARDENINI odobreni servisni partnerji ali pri tem niso bili uporabljeni originalni GARDENINI nadomestni deli ali GARDENINIMI homologiranimi nadomestnimi deli.</p>
<p>HR Pouzdanost proizvoda Sukladno njemačkom zakonu o pouzdanosti proizvoda, ovime izričito izjavljujemo kako ne prihvaćamo nikakvu odgovornost za oštećenja na našim proizvodima nastala uslijed neispravnog popravka od strane servisnog partnera kojeg odobrava GARDENA ili uslijed nekorištenja originalnih GARDENA dijelova ili dijelova koje odobrava GARDENA.</p>
<p>RO Răspunderea pentru produs În conformitate cu Legea germană privind răspunderea pentru produs, declarăm în mod expres prin prezentul document că nu acceptăm nicio răspundere pentru defecțiunile suferite de produsele noastre atunci când acestea nu au fost reparate în mod corect de un atelier de service partener, aprobat de GARDENA, sau când nu au fost utilizate piese GARDENA originale sau piese autorizate de GARDENA.</p>
<p>BG Отговорност за вреди, причинени от стоки Съгласно германския Закон за отговорността за вреди, причинени от стоки, с настоящото изрично декларираме, че не носим отговорност за щети, причинени от нашите продукти, ако те не са били правилно ремонтирани от одобрен от GARDENA сервиз или ако не са използвани оригинални части на GARDENA или части, одобрени от GARDENA.</p>
<p>ET Tootevastutus Vastavalt Saksamaa tootevastutusseadusele deklareerime käesolevaga selgesõnaliselt, et me ei kanna mingisugust vastutust meie toodetest tingitud kahjude eest, kui need tooted ei ole korrektselt parandatud GARDENA heakskiidetud hoolduspartneri poolt või kui parandamisel ei ole kasutatud GARDENA originaalosi või GARDENA volitatud osi.</p>
<p>LT Gaminio patikimumas Mes aiškiai pareiškiame, kad, atsižvelgiant į Vokietijos gaminių patikimumo įstatymą, nepriisiame atsakomybės dėl bet kokios žalos, patirtos dėl mūsų gaminių, jeigu jie buvo netinkamai taisomi arba jų dalys buvo pakeistos neoriginaliomis GARDENA dalimis ar nepatvirtintomis dalimis, arba jeigu remonto darbai buvo atliekami ne GARDENA techninės priežiūros centro specialistų.</p>
<p>LV Atbildība par produkcijas kvalitāti Saskaņā ar Vācijas likumu par atbildību par produkcijas kvalitāti ar šo mēs paziņojam, ka neuzņemamies atbildību par bojājumiem, kas radušies, lietojot mūsu izstrādājumus, kuru remontu nav veicis uzņēmuma GARDENA apstiprināts apkopes partneris vai kuru remontam netika izmantotas oriģinālās GARDENA detaļas vai detaļas, kuru lietošanu apstiprinājis uzņēmums GARDENA.</p>

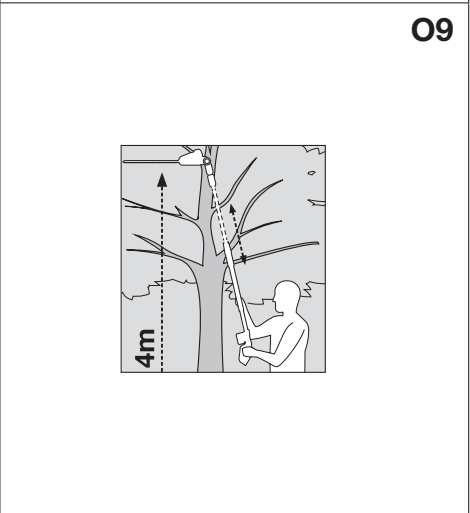
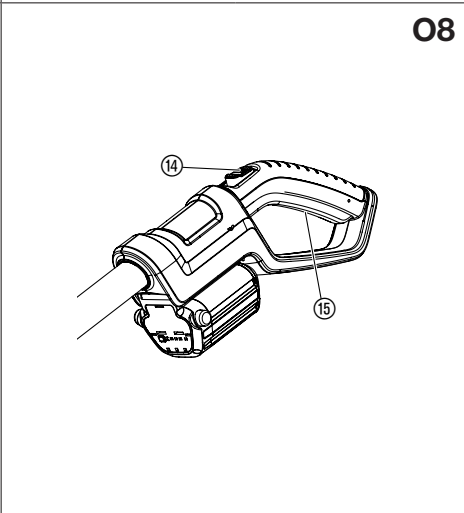
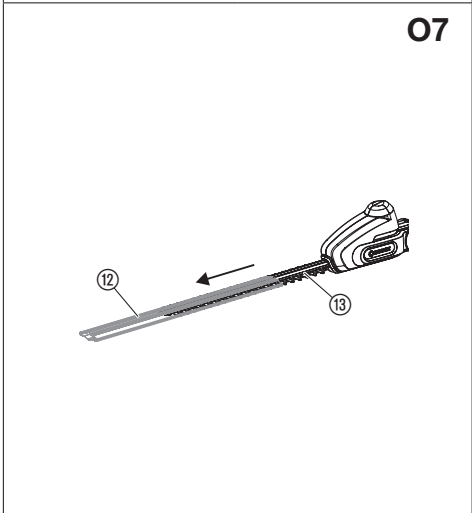
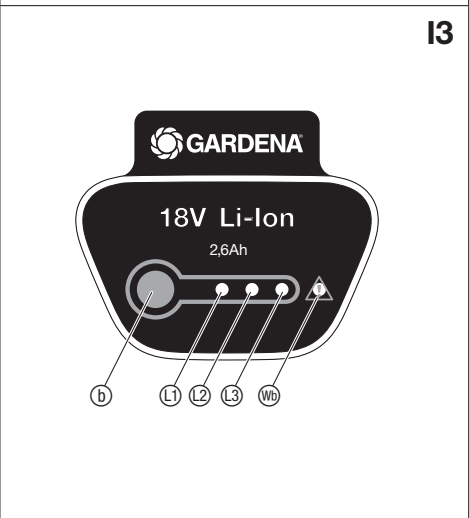
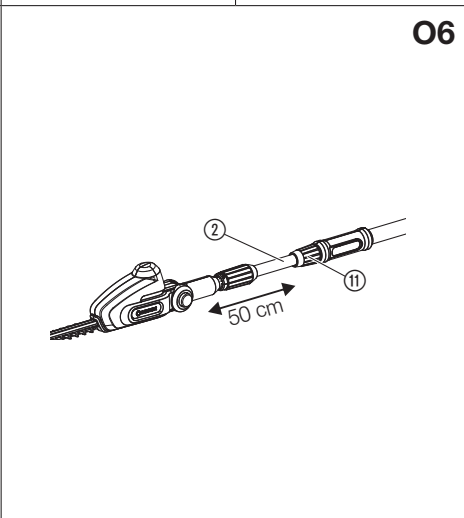
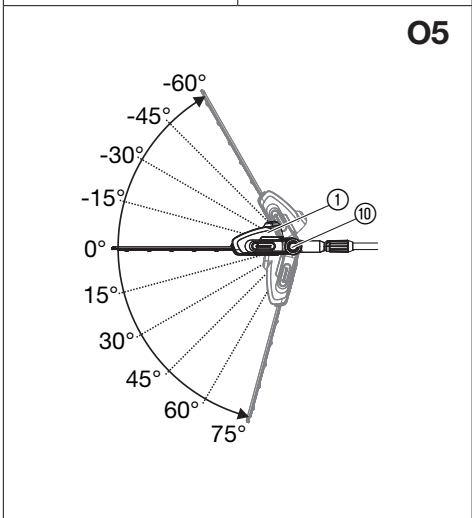
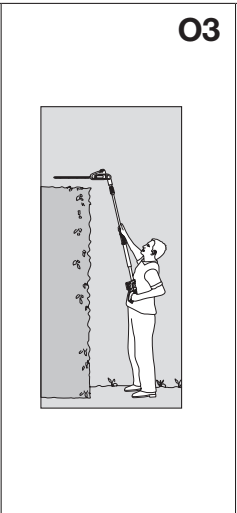
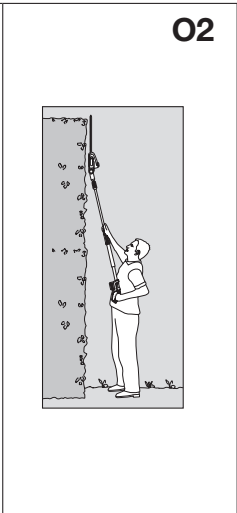
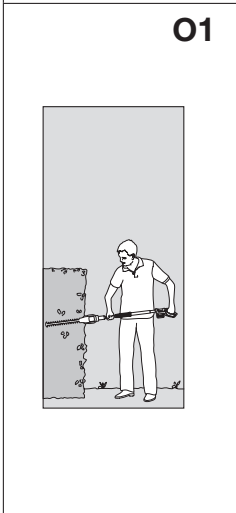
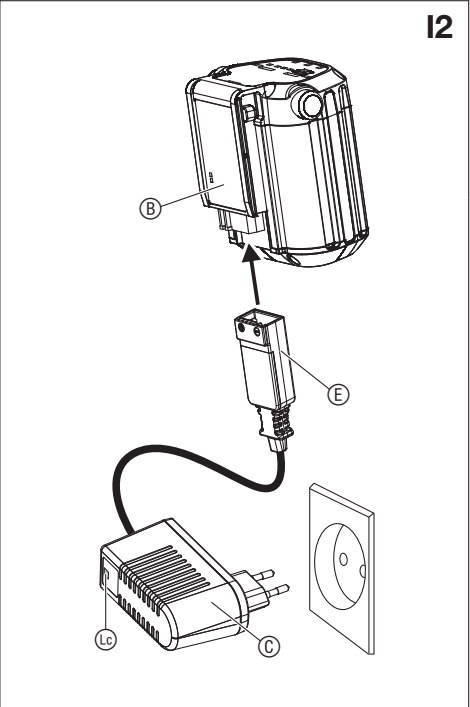
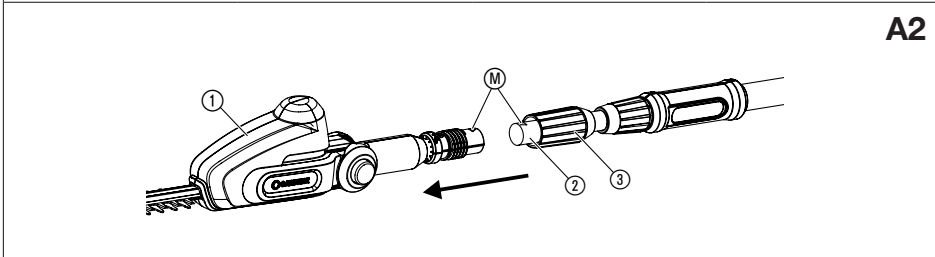
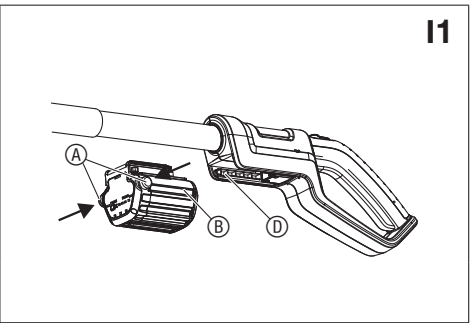
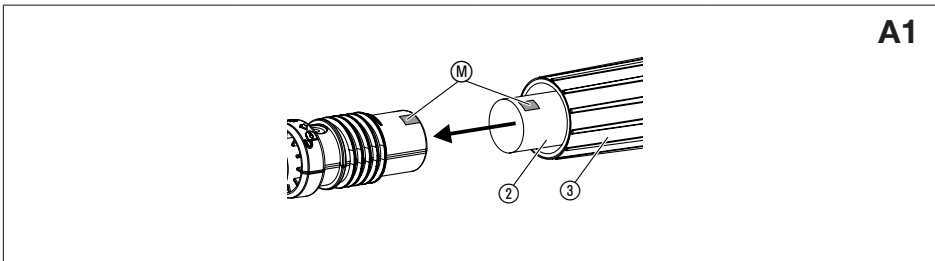

1. SAFETY

IMPORTANT!

Read the operator's manual carefully before use and keep for future reference.



If not used properly this product can be dangerous. The warnings and safety instructions must be followed to ensure reasonable safety and efficiency in using this product. The operator is responsible for following the warnings and instructions in this manual and on the product. Never use the product unless the guards provided by the manufacturer are in the correct position.

Symbols on the product:



WARNING!

Read the user instructions carefully to make sure you understand all the controls and what they do.



Risk of fatal injury due to electric shock!
Keep at least 10 m away from electricity lines.



Danger – Keep hands away from blade.



Always wear eye and ear protection.



Do not expose to rain.
Do not leave the product outdoors while it is raining.

General Power Tool Safety Warnings



WARNING! Read all safety warnings and all instructions.

Failure to follow the warnings and instructions may result in electric shock, fire and/or serious injury.

Save all warnings and instructions for future reference.

The term "power tool" in the warnings refers to your mains operated (corded) power tool or battery-operated (cordless) power tool.

1) Work area safety

a) Keep work area clean and well lit.

Cluttered or dark areas invite accidents.

b) Do not operate power tools in explosive atmospheres, such as in the presence of flammable liquids, gases or dust.

EPower tools create sparks which may ignite the dust or fumes.

c) Keep children and bystanders away while operating a power tool.

Distractions can cause you to lose control.

2) Electrical safety

a) Power tool plugs must match the outlet. Never modify the plug in any way. Do not use any adaptor plugs with earthed (grounded) power tools.

Unmodified plugs and matching outlets will reduce risk of electric shock.

b) Avoid body contact with earthed or grounded surfaces, such as pipes, radiators, ranges and refrigerators. There is an increased risk of electric shock if your body is earthed or grounded.

c) Do not expose power tools to rain or wet conditions.

Water entering a power tool will increase the risk of electric shock.

d) Do not abuse the cord. Never use the cord for carrying, pulling or unplugging the power tool. Keep cord away from heat, oil, sharp edges or moving parts.

Damaged or entangled cords increase the risk of electric shock.

e) When operating a power tool outdoors, use an extension cord suitable for outdoor use.

Use of a cord suitable for outdoor use reduces the risk of electric shock.

f) If operating a power tool in a damp location is unavoidable, use a residual current device (RCD) protected supply.

Use of an RCD reduces the risk of electric shock.

3) Personal safety

a) Stay alert, watch what you are doing and use common sense when operating a power tool. Do not use a power tool while you are tired or under the influence of drugs, alcohol or medication. A moment of inattention while operating power tools may result in serious personal injury.

b) Use personal protective equipment. Always wear eye protection.

Protective equipment such as dust mask, non-skid safety shoes, hard hat, or hearing protection used for appropriate conditions will reduce personal injuries.

c) Prevent unintentional starting. Ensure the switch is in the off-position before connecting to power source and/or battery pack, picking up or carrying the tool.

EN

Translation of the original instructions.



For safety reasons, children and young people under the age of 16, as well as people not familiar with these operating instructions, may not use this product. Persons with reduced physical or mental abilities may use the product only if they are supervised or instructed by a responsible person. Children must be supervised to ensure that they do not play with the product.

Intended use:

This GARDENA Telescopic Accu Hedge Trimmer is intended for the cutting of hedges, shrubs and grass coverings in private domestic gardens and allotments.

Adherence to these operating instructions is a precondition for the correct use of the hedge trimmer.

DANGER! Risk of injury! The hedge trimmer must not be used for cutting lawns/lawn edges or for chopping up material for composting purposes.

Carrying power tools with your finger on the switch or energising power tools that have the switch on invites accidents.

- d) **Remove any adjusting key or wrench before turning the power tool on.**
A wrench or a key left attached to a rotating part of the power tools may result in personal injury.
- e) **Do not overreach. Keep proper footing and balance at all times.**
This enables better control of the power tool in unexpected situations.
- f) **Dress properly. Do not wear loose clothing or jewellery. Keep your hair, clothing and gloves away from moving parts.**
Loose clothes, jewellery or long hair can be caught in moving parts.
- g) **If devices are provided for the connection of dust extraction and collection facilities, ensure these are connected and properly used.**
Use of dust collection can reduce dust-related hazards.
- 4) **Power tool use and care**
- a) **Do not force the power tool. Use the correct power tool for your application.** The correct power tool will do the job better and safer at the rate for which it was designed.
- b) **Do not use the power tool if the switch does not turn it on and off.**
Any power tool that cannot be controlled with the switch is dangerous and must be repaired.
- c) **Disconnect the plug from the power source and /or the battery pack from the power tool before making any adjustments, changing accessories, or storing power tools.** Such preventive safety measures reduce the risk of starting the power tool accidentally.
- d) **Store idle power tools out of the reach of children and do not allow persons unfamiliar with the power tool or these instructions to operate the power tool.**
Power tools are dangerous in the hands of untrained users.
- e) **Maintain power tools. Check for misalignment or binding of moving parts, breakage of parts and any other condition that may affect the power tool's operation. If damaged, have the power tool repaired before use.** Many accidents are caused by poorly maintained power tools.
- f) **Keep cutting tools sharp and clean.** Properly maintained cutting tools with sharp cutting edges are less likely to bind and are easier to control.
- g) **Use the power tool, accessories and tool bits etc. in accordance with these instructions, taking into account the working conditions and the work to be performed.** Use of the power tool for operations different from those intended could result in a hazardous situation.

5) Battery tool use and care

- a) **Recharge only with the charger specified by the manufacturer.**
A charger that is suitable for one type of battery pack may create a risk of fire when used with another battery pack.
- b) **Use power tools only with specifically designated battery packs.**
Use of any other battery packs may create a risk of injury and fire.
- c) **When battery pack is not in use, keep it away from other metal objects, like paper clips, coins, keys, nails, screws or other small metal objects, that can make a connection from one terminal to another.** Shorting the battery terminals together may cause burns or a fire.
- d) **Under abusive conditions, liquid may be ejected from the battery; avoid contact. If contact accidentally occurs, flush with water. If liquid contacts eyes, additionally seek medical help.**
Liquid ejected from the battery may cause irritation or burns.

6) Service

Have your power tool serviced by a qualified repair person using only identical replacement parts.
This will ensure that the safety of the power tool is maintained.

Hedge trimmer safety warnings:

- **Keep all parts of the body away from the cutter blade. Do not remove cut material or hold material to be cut when blades are moving. Make sure the switch is off when clearing jammed material.** A moment of inattention while operating the hedge trimmer may result in serious personal injury.
- **Carry the hedge trimmer by the handle with the cutter blade stopped. When transporting or storing the hedge trimmer always fit the cutting device cover.** Proper handling of the hedge trimmer will reduce possible personal injury from the cutter blades.
- **Hold the power tool by insulated gripping surfaces only, because the cutter blade may contact hidden wiring.**
Cutter blades contacting a "live" wire may make exposed metal parts of the power tool "live" and could give the operator an electric shock.

Additional safety warnings

Work area safety

Only use the product in the manner and for the functions described in these instructions. The operator or user is responsible for accidents or hazards occurring to other people or their property. Pay special attention to the hazard for third parties posed by the increased working radius when the telescopic tube is extended.

DANGER! When wearing hearing protection, and due to the noise produced by the unit, the operator may not notice persons approaching.

DANGER! This product makes an electromagnetic field while it operates. This field may under some conditions interfere with active or passive medical implants. To decrease the risk of conditions that can possibly injure or kill, we recommend persons with medical implants to speak with their physician and the medical implant manufacturer before you operate the product.

Do not use the product when a thunderstorm is approaching.

DANGER! Small parts can be easily swallowed. There is also a risk that the polybag can suffocate toddlers. Keep toddlers away when you assemble the product.

Electrical safety

Only connect charger to the AC voltage specified on the rating plate. Under no circumstances should an earth be connected to any part of the product.

Personal safety

Always wear suitable clothing, gloves, and stout shoes.

Avoid contact to the oil of the blade in particular when you react allergic with it.

All adjustments (inclining the blade head, altering the length of the telescopic tube) have to be made with the sheath in place, and the Hedge Trimmer must not rest on the blade in the process.

Before using the machine and after any impact, check for signs of wear or damage and repair as necessary.

Never attempt to use an incomplete product or one with an unauthorised modification.

Power tool use and care

Know how to stop the product quickly in an emergency.

Never hold the product by the guard.

Do not use the Hedge Trimmer if the protection equipment are damaged.

Do not use ladders whilst operating the product.

Remove the battery:

- before leaving the product unattended for any period;
- before clearing a blockage;
- before checking, cleaning or working on the appliance;
- if you hit an object. Do not use your product until you are sure that the entire product is in a safe operating condition;
- if the product starts to vibrate abnormally. Check immediately. Excessive vibration can cause injury.
- before passing to another person.

Maintenance and storage



RISK OF INJURY!

Do not touch blades.

→ **When work is finished or interrupted, refit the protective blade cover.**

All nuts and screws must be firmly tightened to ensure a safe operating condition of the device.

If the unit got hot during operation, let it cool down before storage.

Battery safety



DANGER! Fire risk!

The battery to be charged must be placed on a nonflammable, heat resistant and non-conductive surface while charging.

The supply terminals are not to be short-circuited.

Keep corrosive, flammable and easily combustible objects clear of the battery charger and the battery.

Do not cover the battery charger and the battery while charging.

Disconnect the battery charger immediately in the event of smoke formation or fire.

Only use the original GARDENA Charger to charge the battery. The use of other battery chargers may damage the batteries irreparably and even cause a fire.

Only use original GARDENA batteries for the GARDENA battery product.

Do not charge any third-party batteries. There is a risk of fire and explosion!

If you notice fire: Extinguish the flames with oxygen reducing materials.



DANGER! Risk of explosion!

Protect batteries from heat and fire. Do not leave on radiators or expose to strong sunshine for long periods.

Do not operate in explosive atmospheres, such as in the presence of flammable liquids, gases, or dust. Batteries may create sparks which could ignite the dust or fumes.

Check your replacement battery before each use. Visually check the battery before each use. A non-functioning battery must be disposed of correctly. Do not send by post. For further details, please contact your local disposal companies.

For risks of injury do not use the battery as a power source for other products. Only use the battery for the GARDENA product intended.

Only charge and use the battery in ambient temperatures of between 0 °C and 40 °C. Allow battery to cool down after long periods of use.

Check the charging cable regularly for signs of damage or ageing (brittleness). Only use it in perfect condition.

Do not stow or transport the battery above 45 °C or in direct sunlight. Ideally, the battery should be stored below 25 °C so that self-discharge is low.

Do not expose the battery to rain or wet conditions. Water entering a battery will increase the risk of electric shock.

Keep battery in order (clean) especially air vents.

If usage of the battery is not planned for a certain time (winter period) reload the battery to avoid a deep discharge.

Do not store while still attached to a tool, this prevents misuse and accidents.
Do not store the battery in places where static electricity is present.



Do not use the battery charger outdoors.

→ **Protect battery from heat and fire.**

Storage

The Hedge trimmer must not be stored over 35 °C or under direct exposure to sunlight.

Do not store the Hedge Trimmer in places with static electricity.

2. ASSEMBLY

Installing the telescopic handle [Fig. A1/A2]:

- Slide telescopic pipe ② into the motor unit ① until you reach the stop position. Ensure that the two markings ④ face each other.
- Tighten the grey nut ③.

3. INITIAL OPERATION

To charge the battery [Fig. I1/I2]:



CAUTION!

Overvoltage damages the battery and the battery charger.

→ **Make sure that you use the correct mains voltage.**

Before you use the battery the first time, the battery must be completely charged.

The lithium-ion battery can be charged in any state of charge and the charging process can be disconnected at any time without to damage the battery (no memory effect).

- Push both locking buttons ① and remove the battery ② from the battery holder ③.
 - Connect the battery charger ④ into a mains socket.
 - Connect the battery charger cable ⑤ to the battery ②.
- When the charging control lamp ⑥ at the charger flashes green the battery is being charged.**
- When the charging control lamp ⑥ at the charger illuminates green the battery is completely charged** (charging time, see 8. TECHNICAL DATA).
- Examine the charge status regularly while you charge.
 - When the battery ② is completely charged, disconnect the battery ② from the charger ④.
 - Disconnect the charger ④ from the mains.

Battery charging indicator [Fig. I3]:

Battery charging indicator during charging:

100 % charged	①, ② and ③ illuminate (for 60 sec.)
66 – 99 % charged	① and ② illuminate, ③ flashing
33 – 65 % charged	① illuminates, ② flashes
0 – 32 % charged	① flashes

Battery charging indicator during operation:

→ Push the button ④ on the battery.

66 – 99 % charged	①, ② and ③ illuminate
33 – 65 % charged	① and ② illuminate
11 – 32 % charged	① illuminates
0 – 10 % charged	① flashes

4. OPERATION

Work positions:

The hedge trimmer can be operated in 4 working positions.

- [Fig. O1]: **Side trimming: Telescopic pipe retracted**
- [Fig. O2]: **Vertical trimming at high level: Telescopic tube extended**
- [Fig. O3]: **Horizontal trimming at high level: Motor unit tilted by 75°, telescopic pipe extended**
- [Fig. O4]: **Trimming at low level: Motor unit tilted by – 60°, telescopic pipe extended**

Tilting the motor unit [Fig. O5]:

For trimming at high and low level, the motor unit ① can be tilted at an angle of 75° to – 60 in 15° increments.

- Remove the battery from the handle (see 3. INITIAL OPERATION).
- Keep both orange buttons ⑩ pressed.
- Tilt motor unit ① in the required direction.
- Release both orange buttons ⑩ and allow motor unit ① to engage.
- Put the battery on the handle (see 3. INITIAL OPERATION).

Extending the telescopic pipe [Fig. O6]:

For cutting at high and low heights, the telescopic pipe ② can be continuously extended by up to 50 cm.

- Remove the battery from the handle (see 3. INITIAL OPERATION).
- Loosen the orange nut ⑪, extend the telescopic pipe ② to the required length, and tighten the orange nut ⑪ again.
- Put the battery on the handle (see 3. INITIAL OPERATION).

Starting the Hedge Trimmer [Fig. O7/O8/O9]:



DANGER! Risk of injury!

If the Hedge Trimmer does not switch off automatically, there is a risk of lacerations.

→ **Never override the safety devices (e.g. by strapping down the starting lock-out or the start button).**

To start:

- Remove the protective cover ⑫ from blade ⑬.
- Put the battery on the handle (see 3. INITIAL OPERATION).
- Hold the telescopic pipe of the Hedge Trimmer with one hand and the handle with the other hand.
- Push the starting lock-out ⑭ forwards and press the start button ⑮.
The Hedge Trimmer will start.
- Release the starting lock-out ⑭.

To stop:

- Release the start button ⑮.
- Remove the battery from the handle (see 3. INITIAL OPERATION).
- Slide the protective cover ⑫ over the cutter blade ⑬.

5. MAINTENANCE

[Fig. O7]:



DANGER! Risk of injury!

Cutting injuries can be caused if the hedge trimmer does switch on unintentionally.

→ **Before maintenance, remove the battery (see 3. INITIAL OPERATION) and slide the protective cover ⑫ over the cutter blade ⑬.**

Cleaning the Hedge Trimmer:



DANGER! Risk of injury!

Risk of injury and risk of damage to the product.

→ **Do not clean the product with water or with a water jet (in particular high-pressure water jet).**

→ **Do not clean with chemicals including petrol or solvents. Some can destroy critical plastic parts.**

The airflow slots must always be clean.

- Clean the hedge trimmer with a damp cloth.
- Clean the airflow slots with a soft brush (do not use a screwdriver).
- Clean the blade ⑬ with a brush, if required, and lubricate with a low-viscosity oil (e.g. GARDENA Spray Oil Art. 2366).
Avoid contact of the oil with the plastic parts and wear gloves.

To clean the battery and the battery charger:

Make sure that the surface and the contacts of the battery and the battery charger always are clean and dry before you connect the battery charger.

Do not use running water.

→ Clean the contacts and the plastic parts with a soft and dry cloth.

6. STORAGE

To put into storage [Fig. O7]:

The product must be stored away from children.

1. Remove and charge battery (see 3. INITIAL OPERATION).
2. Clean the hedge trimmer (see 5. MAINTENANCE) and slide the protective cover ⑫ over the cutter blade ⑬.
3. Store the hedge trimmer in a dry, frost free place.

Disposal:

(in accordance with RL2012/19/EC)

The product must not be disposed of to normal household waste. It must be disposed of in line with local environmental regulations.



IMPORTANT!

→ Dispose of the product through or via your municipal recycling collection centre.

Disposal of the battery:

The GARDENA battery contains lithium-ion cells that should not be disposed of with normal household waste at the end of its life.



IMPORTANT!

→ Dispose of the batteries through or via your municipal recycling collection centre.

1. Discharge the lithium-ion cells completely (contact the GARDENA Service).
2. Protect the contacts on the lithium-ion cells against short circuits.
3. Dispose of the lithium-ion cells properly.

7. TROUBLESHOOTING



DANGER! Risk of injury!

Cutting injuries can be caused if the hedge trimmer does switch on unintentionally.

→ Remove the battery before troubleshooting (see 3. INITIAL OPERATION) and slide the protective cover ⑫ over the cutter blade ⑬ [Fig. O7].

Problem	Possible Cause	Remedy
Hedge trimmer does not start	Battery is flat.	→ Charge battery (see 3. INITIAL OPERATION).
	Battery not pushed onto the handle properly.	→ Push battery onto the handle and make sure that the locking buttons snaps in correctly.
	Blade soiled (e. g. by resin).	→ Clean blade (see 5. MAINTENANCE).
	Blade blocked.	→ Remove obstacle.
Hedge is not cleanly cut	Blade blunt or damaged.	→ Have blade replaced by GARDENA-Service.
The Hedge Trimmer can no longer be switched off	Start button is stuck.	→ Remove battery and loosen start button.
Hedge Trimmer stops. Error-LED ⑩ flashes	Battery overload.	→ Wait for 10 sec. Press button ⑪ on the battery and restart.
	High temperature. The allowed operation temperature was exceeded.	→ Leave battery to cool for approx. 15 min. Press button ⑪ on the battery and restart.
Charging control lamp ⑬ on the charger does not illuminate	Battery charger or charging cable are not connected correctly.	→ Connect the battery charger and charging cable correctly.
Charging control lamp ⑬ on the charger flashes red	Battery temperature is out of range.	→ Use the battery in surroundings where temperatures are between 0 °C and 40 °C.
Hedge Trimmer stops. Error-LED ⑩ flashes	Battery error/ battery defective.	→ Press button ⑪ on the battery and restart.
The battery can no longer be charged	Battery is defective.	→ Replace the battery (Art. 9839).

Only an original GARDENA BLi-18 Replaceable Battery (Art. 9839) may be used. This can be obtained from your GARDENA dealer or directly from GARDENA Service.



NOTE: For any other malfunctions please contact the GARDENA service department. Repairs must only be done by GARDENA service departments or specialist dealers approved by GARDENA.

8. TECHNICAL DATA

Telescopic Accu Hedge Trimmer	Unit	Value (Art. 8881)
Strokes	/ min.	2100
Length of cutter blade	cm	42
Tooth gap of cutter blade	mm	16
Range of extension of telescopic tube	cm	0 – 50
Weight (including battery)	kg	3.4
Sound pressure level $L_{pA}^{1)}$ Uncertainty k_{pA}	dB (A)	70 3
Sound power level $L_{WA}^{2)}$: measured/guaranteed Uncertainty k_{WA}	dB (A)	87 / 90 3
Hand/arm vibration $a_{vhw}^{1)}$ Uncertainty k_a	m/s ²	< 2.5 1.5

Measuring process complying with: ¹⁾ EN 60745-2-15 ²⁾ RL2000/14/EC



NOTE: The stated vibration emission value has been measured according to a standardized test procedure and can be used for comparison of one electric power tool with another. It can also be used for preliminary evaluation of exposure. The vibration emission value can vary during actual use of the electric power tool.

System Battery BLi-18	Unit	Value (Art. 9839)
Battery voltage	V (DC)	18
Battery capacity	Ah	2.6
Battery charging time 80 % / 100 % (approx.)	h	3,5 / 5

Battery Charger 18 V	Unit	Value (Art. 9825-00.630.00)
Mains voltage	V (AC)	230
Mains frequency	Hz	50
Rated Power	W	16
Output voltage	V (DC)	18
Max. output current	mA	600

9. ACCESSORIES

GARDENA Replacement Battery BLi-18	Battery for additional duration or for replacement.	Art. 9839
GARDENA Battery Charger 18 V	Charger to charge the GARDENA Batteries BLi-18.	Art. 8833
GARDENA Maintenance Oil	Increases the service life of the blade and battery life.	Art. 2366

10. SERVICE/WARRANTY

Service:

Please contact the address on the back page.

Warranty:

In the event of a warranty claim, no charge is levied to you for the services provided.

GARDENA Manufacturing GmbH offers a 2-year warranty for this product (from the date of purchase) if the product has been used exclusively for private purposes. This manufacturer's warranty does not apply to used products purchased from a secondary market. This warranty includes all significant defects of the product that can be proved to be material or manufacturing faults. This warranty is fulfilled by supplying a fully functional replacement product or by repairing the faulty product sent to us free of charge; we reserve the right to choose between these options. This service is subject to the following provisions:

- The product was used for its intended purpose as per the recommendations in the operating instructions.
- Neither the purchaser nor a third party has attempted to repair the product.
- Only original GARDENA spare and wear parts were used.

Normal wear and tear of parts and components, optical changes, as well as wear parts and consumables, are excluded from the warranty.

This manufacturer's warranty does not affect warranty entitlements against the dealer/retailer.

If problems arise with this product, please contact our Service department. In the event of a warranty claim, please send the defective product together with a copy of the purchase receipt and a description of the defect, sufficiently stamped, to the GARDENA service address on the back page.

Consumables:

The blade and eccentric drive are wearing parts and are not covered by the guarantee.

<p>DE EU-Konformitätserklärung Der Unterzeichner, GARDENA Germany AB, PO Box 7454, S-103 92 Stockholm, Schweden, bescheinigt hiermit, dass die nachstehend aufgeführten Produkte bei Verlassen des Werks die harmonisierten EU-Leitlinien, EU-Normen für Sicherheit und besondere Normen erfüllen. Dieses Zertifikat verliert seine Gültigkeit, wenn die Produkte ohne unsere Genehmigung verändert werden.</p>	<p>HU EK megfeleléségi nyilatkozat Alulírott GARDENA Germany AB, PO Box 7454, S-103 92 Stockholm, Svédország, ezzel tanúsítja, hogy az alábbiakban leírt egységek a gyár elhagyásakor megfeleltek a harmonizált uniós előírásoknak és biztonságú és termékspecifikus szabványoknak. Ez a tanúsítvány érvényét veszti, ha az egységeket jóváhagyásunk nélkül átalakítják.</p>
<p>EN EC Declaration of Conformity The undersigned, GARDENA Germany AB, PO Box 7454, S-103 92 Stockholm, Sweden, hereby certifies that, when leaving our factory, the units indicated below are in accordance with the harmonised EU guidelines, EU standards of safety and product specific standards. This certificate becomes void if the units are modified without our approval.</p>	<p>CS Prohlášení o shodě ES Niže uvedená společnost GARDENA Germany AB, PO Box 7454, S-103 92 Stockholm, Švédsko, tímto potvrzuje, že při opuštění naší továrny jsou jednotky uvedené níže v souladu s harmonizačními pokyny EU, standardy EU ohledně bezpečnosti a specifickými produktovými standardy. Tento certifikát pozbyvá platnosti, pokud dojde k úpravě jednotek bez našeho schválení.</p>
<p>FR Déclaration de conformité CE Le constructeur, soussigné : GARDENA Germany AB, PO Box 7454, S-103 92 Stockholm, Suède, déclare qu'à la sortie de ses usines le matériel neuf désigné ci-dessous était conforme aux prescriptions des directives européennes énoncées ciaprès et conforme aux règles de sécurité et autres règles qui lui sont applicables dans le cadre de l'Union européenne. Toute modification apportée à cet appareil sans notre accord annule la validité de ce certificat.</p>	<p>SK EÚ vyhlásenie o zhode Dotu podpísaná spoločnosť GARDENA Germany AB, PO Box 7454, S-103 92 Stockholm, týmto osvedčuje, že nižšie uvedené jednotky boli v súlade s harmonizačnými usmerneniami EÚ, normami EÚ v oblasti bezpečnosti a špecifickými normami týkajúcimi sa produktu v čase opustenia výrobného závodu. Toto osvedčenie stráca platnosť, ak boli jednotky zmenené bez nášho súhlasu.</p>
<p>NL EG-conformiteitsverklaring De ondergetekende, GARDENA Germany AB, PO Box 7454, S-103 92 Stockholm, Zweden, verklaart hierbij dat de producten die hieronder staan vermeld, wanneer ze onze fabriek verlaten, in overeenstemming zijn met de geharmoniseerde Europese richtlijnen, EU-normen voor veiligheid en productspecifieke normen. Dit certificaat vervalt als de producten worden aangepast zonder onze toestemming.</p>	<p>EL Δήλωση Συμμόρφωσης EK Η υπογεγραμμένη εταιρεία, GARDENA Germany AB, PO Box 7454, S-103 92 Stockholm, Σουηδία, πιστοποιεί ότι, κατά την έξοδο από το εργοστάσιο, οι μονάδες που αναφέρονται κατωτέρω συμμορφώνονται με τις εναρμονισμένες οδηγίες ΕΕ, τα πρότυπα ασφαλείας της ΕΕ και τα συγκεκριμένα πρότυπα προϊόντος. Αυτό το πιστοποιητικό καθίσταται άκυρο εάν οι μονάδες έχουν τροποποιηθεί χωρίς την έγκρισή μας.</p>
<p>SV EG-försäkran om överensstämmelse Undertecknad firma GARDENA Germany AB, PO Box 7454, S-103 92 Stockholm, Sverige, intygar härmed att nedan nämnda produkter, när de lämnar vår fabrik, överensstämmer med EU:s riktlinjer, EU:s säkerhetsstandarder och produktspecifika standarder. Detta intyg skall ogiltigförklaras om produkten ändras utan vårt godkännande.</p>	<p>SL Izjava ES o skladnosti Spodaj podpisana, GARDENA Germany AB, PO Box 7454, S-103 92 Stockholm, Švedska, s to izjavo potrjuje, da je bila spodaj navedena enota ob izhodu iz tovarne skladna z usklajenimi smernicami EU, standardi EU za varnost in standardi, specifični za izdele. Izjava postane neveljavna v primeru neodobrene spremembe enote.</p>
<p>DA EU-overensstemmelseserklæring Undertegnede, GARDENA Germany AB, PO Box 7454, S-103 92 Stockholm, Sverige, erklærer hermed, at nedenfor anførte enheder er i overensstemmelse med de harmoniserede EU-retningslinjer, EU-standarder for sikkerhed og produktspecifikke standarder, når de forlader fabrikken. Denne erklæring ugyldiggøres, hvis enhederne ændres uden vores godkendelse.</p>	<p>HR Izjava o usklađenosti EZ Niže potpisana GARDENA Germany AB, PO Box 7454, S-103 92 Stockholm, Švedska, ovime potvrđuje kako su u nastavku navedene jedinice prilikom napuštanja tvornice bile u skladu s usklađenim smjernicama EU, EU sigurnosnim standardima i standardima specifičnima za proizvod. Ova certifikacija poništava se ako se jedinice izmjenjuju bez odobrenja.</p>
<p>FI EY-vaatimustenmukaisuusvakuutus GARDENA Germany AB, PO Box 7454, S-103 92 Stockholm, Ruotsi, vakuuttaa täten, että alla mainitut laitteet ovat tehtaalta lähtessään yhdenmukaistettujen EU-säännösten, EU:n turvastandardien ja tuotekohtaisten standardien mukaisia. Tämä vakuutus mitätöityy, jos laitetta muutetaan ilman hyväksyntäämme.</p>	<p>RO Declarație de conformitate CE Subscrisa, GARDENA Germany AB, PO Box 7454, S-103 92 Stockholm, Suedia, certifică prin prezenta că, la momentul ieșirii din fabrica noastră, unitățile indicate mai jos sunt în conformitate cu directivele UE armonizate, cu standardele UE de siguranță și cu standardele specifice ale produsului. Prezentul certificat devine nul dacă unitățile sunt modificate fără aprobarea noastră.</p>
<p>IT Dichiarazione di conformità CE La sottoscritta GARDENA Germany AB, PO Box 7454, S-103 92 Stockholm, Svezia, certifica che il prodotto qui di seguito indicato, nei modelli da noi commercializzati, è conforme alle direttive armonizzate UE nonché agli standard di sicurezza UE e agli standard specifici di prodotto. Qualunque modifica apportata al prodotto senza nostra specifica autorizzazione invalida la presente dichiarazione.</p>	<p>BG Декларация за съответствие на ЕО С настоящото допълнително подписана, GARDENA Germany AB, PO Box 7454, S-103 92 Stockholm, Швеция, удостоверява, че при напускане на фабриката модулите, посочени по-долу, са в съответствие с хармонизираните директиви на ЕС, стандартите на ЕС за безопасност и специфичните за продукта стандарти. Този сертификат става невалиден, ако модулите са променени без нашето одобрение.</p>
<p>ES Declaración de conformidad CE El abajo firmante, GARDENA Germany AB, PO Box 7454, S-103 92 Stockholm, Suecia, certifica por la presente que, cuando salen de la fábrica, las unidades indicadas a continuación cumplen las normas de armonización de la UE, las normas de la UE sobre seguridad y las normas específicas del producto. Este certificado quedará sin efecto si se modifican las unidades sin nuestra autorización.</p>	<p>ET EÜ vastavusdeklaratsioon Allakirjutanu GARDENA Germany AB, PO Box 7454, S-103 92 Stockholm, Rootsi, kinnitab käesolevaga, et tehased väljumisel vastavad allpool nimetatud seadmed harmoneeritud EL-i suunistele, EL-i ohutusstandarditele ja tootele eriomastele standarditele. See vastavusmääritus kaotab kehtivuse, kui seadmed muudetakse ilma meie heakskiiduta.</p>
<p>PT Declaração de conformidade CE O abaixo-assinado, GARDENA Germany AB, PO Box 7454, S-103 92 Stockholm, Suécia, certifica por este meio que, ao sair da nossa fábrica, as unidades indicadas acima estão em conformidade com as diretrizes uniformizadas da UE, os padrões de segurança da UE e os padrões específicos do produto. Este certificado deixa de ser válido se as unidades forem modificadas sem a nossa aprovação.</p>	<p>LT EB atitikties deklaracija GARDENA Germany AB, PO Box 7454, S-103 92 Stockholm, Sweden, garantuoja, kad iš gamyklos siunčiami toliau nurodyti įrenginiai atitinka suderintus ES reikalavimus, EB saugos ir konkretaus gamtinio standartus. Pakaitus gaminių be mūsų patvirtinimo, nutraukiamas šio sertifikato galiojimas.</p>
<p>PL Deklaracja zgodności WE Niżej podpisany przedstawiciel firmy GARDENA Germany AB, PO Box 7454, S-103 92 Stockholm, Szwecja, niniejszym oświadcza, że podane poniżej wyroby opuszczające fabrykę są zgodne ze zharmonizowanymi normami UE oraz z obowiązującymi w UE przepisami bezpieczeństwa i normami dotyczącymi danego produktu. Modyfikacja wyrobów bez naszej zgody powoduje u nieważnienie niniejszego certyfikatu.</p>	<p>LV EK atbilstības deklarācija Uzņēmums GARDENA Germany AB, PO Box 7454, S-103 92 Stockholm, Zviedrija, ar parakstu apliecinā, ka tālāk minētās vienības, pamatot rūpnieciski, atbilst saskaņotajām ES vadlīnijām, ES drošības standartiem un izstrādājuma specifiskajiem standartiem. Šis sertifikāts tiek anulēts, ja šīs vienības tiek modificētas bez mūsu apstiprinājuma.</p>

<p>Produktbezeichnung: Description of the product: Désignation du produit : Beschrijving van het product: Beskrivning av produkten: Beskrivelse af produktet: Tuotteen kuvaus: Descrizione del prodotto: Descripción del producto: Descrição do produto: Opis produktu: A termék leírása: Popis výrobku: Popis produktu: Περιγραφή του προϊόντος: Opis izdelka: Opis proizvoda: Descrierea produsului: Описание на продукта: Toote kirjeldus: Gaminio aprašas: Izstrādājuma apraksts:</p>	<p>Accu-Teleskop-Heckenschere Telescopic Accu Hedge Trimmer Taille-haies télescopique sur accu Telescopische accu-heggenschaar Accu Teleskophäcksax Akku-teleskop-hækkeklipper Teleskoopivarrellinen akkupensasleikkuri Tagliasiepi telescopica a batteria Recortasietos telescópico con Accu Corta-sebes telescópico accu Akumulatorowe nożyce do żywoplotu z trzonkiem teleskopowym Akkumulátoros-telepszópos sövénynyíró Akumulatorové teleskopické nožičky na živý plot Akumulatorové nožnice na živý plot Τηλεσκοπικό υπογρουπούραίο ματαρίσις Akumulatorске teleskopske škarje za živo mejo Teleskopske škare za živicu s akumulatorom Trimmer telescopi cu acumulator pentru gard viu Акумуляторна телескопична ножица за жив плет Aku ja teleskoopvarrega hekiikäär Akumulatorinés teleskopinés gyvatvorių žirkles Teleskopiskās dzīvžogu šķeres ar akumulatoru</p>	<p>Harmonisierte EN-Normen / Harmonised EN: EN ISO 12100 EN ISO 10517 EN 60745-1 EN 60745-2-15</p> <p>Schall-Leistungspegel: Noise level: Niveau sonore : Geluidsniveau: Ljudnivå: Støjniveau: Ånitaso: Livello acustico: Nivel de ruido: Nivel de ruído: Poziom hałas: Zajszint:</p> <p>gemessen / garantiert measured / guaranteed mesuré / garanti gemeten / gegarandeerd määritetty / garantierad mält / garanteret mittattu / taattu misurato / garantito medido / garantizado medido / garantido zmierzony / gwarantowany mért / garantált</p> <p>Hladina hluku: Hladiny hluku: Επίπεδο θορύβου: Raven zvočne moči: Razina buke: Nivel de zgomot: Ниво на шум: Műratase: Triukšmo lygis: Trokšņa līmenis :</p> <p>naměřená / zaručená nameranjena / zaručené μετρημένο / εγγυημένο mjerena / zagotovljena mjerena / zajamčena măsurat / garantat измерено / гарантирано mōdetud / garanteeritud išmatuotas / garantuojamas mērītais / garantētais</p> <p>87 dB(A) / 90 dB(A)</p> <p>Anbringungsjahr der CE-Kennzeichnung: Year of CE marking: Année d'apposition du marquage CE : Installatiejaar van de CE-aanduiding: Märkningsår: CE-Mærkningsår: CE-merkin kiinnitysvuosi: Anno di applicazione della certificazione CE: Colocación del distintivo CE: Ano de marcação pela CE: Rok nadania oznakowania CE:</p> <p>CE-jelzés elhelyezésének éve: Rok umístění značky CE: Rok udelenia značky CE: Ετος ομάρτυσης CE: Leto namestitve CE-oznake: Godina dobivanja CE oznake: Anul de marcare CE: Година на поставяне на CE-маркировка: CE-mārgistuse paigaldamise aasta: Metai, kada pažymėta CE-ženku: CE-marķējuma uzlikšanas gads: 2013</p> <p>Ulm, den 29.02.2016 Ulm, 29.02.2016 Fait à Ulm, le 29.02.2016 Ulm, 29-02-2016 Ulm, 2016.02.29. Ulm, 29.02.2016 Ulmissa, 29.02.2016 Ulm, 29.02.2016 Ulm, 29.02.2016 Ulm, 29.02.2016 Ulm, dnia 29.02.2016 Ulm, 29.02.2016 Ulm, dnā 29.02.2016 Ulm, 29.02.2016 Ulm, 29.02.2016 Ulm, dana 29.02.2016 Ulm, 29.02.2016 Ulm, 29.02.2016 Ulm, 29.02.2016 Ulm, 29.02.2016 Ulm, 29.02.2016</p> <p>Der Bevollmächtigte Authorised representative Le mandataire De gevolmachtigde Auktoriserad representant Autoriseret repræsntant Valtuutettu edustaja Persona delegata La persona autorizada O representante Pelnomocnik Meghatalmazott Zplnomocnenec Spplnomocneny Ο εξουσιοδοτημένος Pooblaščenec Ovlaštena osoba Conducerea tehnică Упълномощен Volitatud esindaja Igalotasis atstovas Pilnvarotā persona</p> <p><i>Reinhard Pompe</i> Reinhard Pompe Vice President</p>
<p>THS Li-18/42</p> <p>EU-Richtlijnen: EC-Directives: Directives CE : EG-richtlijnen: EU-direktiv: EF-direktiver: EY-direktiivit: Directive UE: Directiva CE: Diretivas CE: Dyrektywy WE: EK-irányelvek: Predpisy ES: Smernice EÚ: Οδηγίες EK: Direktive EU: EC direktive: Directive CE: Директиви на ЕО: EU direktiivid:</p>	<p>Terméktípus: Druh výrobku: Type de produit: Producttype: Πρότυπο προϊόντος: Producttype: Producttype: Tuotetyyppi: Tipo adii produsului: Tipo de producto: Tipo de produto: Typ produktu:</p> <p>EB direktivos: EK direktivas: 2006/42/EG 2014/30/EG 2011/65/EG 2000/14/EG</p> <p>Ladegerät / Battery charger: 2014/35/EG</p>	<p>Artikelnummer: Article number: Référence : Artikelnummer: Artikelnummer: Artikelnummer: Tuotenumero: Codice articolo: Referencia: Número de referência: Numer katalogowy:</p> <p>Cikkszámok: Objednací číslo: Objednávacia číslo: Κωδικός είδους: Številka izdelka: Kataloški broj: Cod articol: Артикул номер: Artikelnummer: Dalies numeris: Artikula numurs:</p> <p>Nach 2000/14/EG Art. 14 Anhang V</p> <p>Conformity Assessment Procedure: according to 2000/14/EG Art.14 Annex V</p> <p>Documentation déposée: Documentation technique GARDENA, M. Kugler 89079 Ulm</p> <p>Procédure d'évaluation de la conformité : Selon 2000/14/CE art. 14 Annexe V</p>

Deutschland / Germany

GARDENA
Manufacturing GmbH
Central Service
Hans-Lorenser-Straße 40
D-89079 Ulm
Produktfragen:
(+49) 731 490-123
Reparaturen:
(+49) 731 490-290
service@gardena.com

Albania

COBALT Sh.p.k.
Rr. Siri Kodra
1000 Tirana

Argentina

Husqvarna Argentina S.A.
Av.del Libertador 5954 –
Piso 11 – Torre B
(C1428ARP) Buenos Aires
Phone: (+54) 11 5194 5000
info.gardena@
ar.husqvarna.com

Armenia

Garden Land Ltd.
61 Tigran Mets
0005 Yerevan

Australia

Husqvarna Australia Pty. Ltd.
Locked Bag 5
Central Coast BC
NSW 2252
Phone: (+61) (0) 2 4352 7400
customer.service@
husqvarna.com.au

Austria / Österreich

Husqvarna Austria GmbH
Industriezeile 36
4010 Linz
Tel.: (+43) 732 77 01 01-485
service.gardena@
husqvarnagroup.com

Azerbaijan

Firm Progress
a. Aliyev Str. 26A
1052 Baku

Belgium

Husqvarna België nv/sa
Gardena Division
Rue Egide Van Ophem 111
1180 Uccle / Ukkel
Tel.: (+32) 2 720 92 12
info@gardena.be

Bosnia / Herzegovina

SILK TRADE d.o.o.
Industrijska zona Bukva bb
74260 Tešanj

Brazil

Husqvarna do Brasil Ltda
Av. Francisco Matarazzo,
1400 – 19º andar
São Paulo – SP
CEP: 05001-903
Tel: 0800-112252
marketing.br.husqvarna@
husqvarna.com.br

Bulgaria

AGROLAND България АД
бул. 8 Декември, №13
Офис 5
1700 Студентски град
София
Тел.: (+359) 24 66 69 10
info@agroland.eu

Canada / USA

GARDENA Canada Ltd.
100 Summerlea Road
Brampton, Ontario L6T 4X3
Phone: (+1) 905 792 93 30
info@gardenacanada.com

Chile

Maquinarias Agroforestales
Ltda. (Maga Ltda.)
Santiago, Chile
Avda. Chesterton
8355 comuna Las Condes
Phone: (+56) 2 202 4417
Dalton@maga.cl
Zipcode: 7560330

China

Husqvarna (Shanghai)
Management Co., Ltd.
富世华 (上海) 管理有限公司
3F, Benq Square B,
No207, Song Hong Rd.,
Chang Ning District,
Shanghai, PRC. 200335
上海市长宁区淞虹路207号明
基广场B座3楼, 邮编: 200335

Colombia

Husqvarna Colombia S.A.
Calle 18 No. 68 D-31, zona
Industrial de Montevideo
Bogotá, Cundinamarca
Tel. 571 2922700 ext. 105
jairo.salazar@
husqvarna.com.co

Costa Rica

Compania Exim
Euroberoamericana S.A.
Los Colegios, Moravia,
200 metros al Sur del Colegio
Saint Francis – San José
Phone: (+506) 297 68 83
exim_euro@racsa.co.cr

Croatia

Husqvarna Austria GmbH
Industriezeile 36
4010 Linz
Tel.: (+43) 732 77 01 01-485
service.gardena@
husqvarnagroup.com

Cyprus

Med Marketing
17 Digeni Akrita Ave
P.O. Box 27017
1641 Nicosia
Czech Republic
Husqvarna Česko s.r.o.
Türkova 2319/5b
149 00 Praha 4 – Chodov
Bezplatná infolinka:
800 100 425
servis@cz.husqvarna.com

Denmark

GARDENA DANMARK
Lejrvej 19, st.
3500 Værløse
Tlf.: (+45) 70 26 47 70
husqvarna@husqvarna.dk
www.gardena.com/dk

Dominican Republic

BOSQUESA, S.R.L
Carretera Santiago Licey
Km. 5 ½
Esquina Copal II.
Santiago
Dominican Republic
Phone: (+809) 736-0333
joserbosquesa@claro.net.do

Ecuador

Husqvarna Ecuador S.A.
Arupos E1-181 y 10 de
Agosto Quito, Pichincha
Tel. (+593) 22800739
francisco.jacome@
husqvarna.com.ec

Estonia

Husqvarna Eesti OÜ
Valdeku 132
EE-11216 Tallinn
info@gardena.ee

Finland

Oy Husqvarna Ab
Gardena Division
Lautatarhankatu 8 B/PL 3
00581 HELSINKI
www.gardena.fi

France

Husqvarna France
9/11 Allée des pierres mayettes
92635 Gennevilliers Cedex
France
http://www.gardena.com/fr
N° AZUR: 0 810 00 78 23
(Prix d'un appel local)

Georgia

Transporter LLC
8/57 Beliashvili street
0159 Tbilisi, Georgia
Phone: (+995) 322 14 71 71

Great Britain

Husqvarna UK Ltd
Preston Road
Aycliffe Industrial Park
Newton Aycliffe
County Durham
DL5 6UP
info.gardena@
husqvarna.co.uk

Greece

Π. ΠΑΠΑΔΟΠΟΥΛΟΣ ΑΕΒΕ
Λεωφ. Αθηνών 92
Αθήνα
T.K.104 42
Ελλάδα
Τηλ. (+30) 210 51 93 100
info@papadopoulos.com.gr

Hungary

Husqvarna Magyarország Kft.
Ezred u. 1-3
1044 Budapest
Telefon: (+36) 1 251-4161
vevoszolgalat.husqvarna@
husqvarna.hu

Iceland

Ó. Johnson & Kaaber
Tunguhalsi 1
110 Reykjavik
ooj@ojk.is

Ireland

Husqvarna UK Ltd
Preston Road
Aycliffe Industrial Park
Newton Aycliffe
County Durham
DL5 6UP
info.gardena@
husqvarna.co.uk

Italy

Husqvarna Italia S.p.A.
Via Santa Vecchia 15
23868 VALMADRERA (LC)
Phone: (+39) 0341.203.111
assistenza.italia@
it.husqvarna.com

Japan

KAKUICHI Co. Ltd.
Sumitomo Realty &
Development Kojimachi
BLDG., 8F
5-1 Nibannco
Chiyoda-ku
Tokyo 102-0084
Phone: (+81) 33 264 4721
m_ishihara@kaku-ichi.co.jp

Kazakhstan

LAMED Ltd.
155/1, Tazhibayevoi Str.
050060 Almaty
IP Schmidt
Abayavenue 3B
110 005 Kostanay

Korea

Kyung Jin Trading CO.,LTD.
107-4, SunDuk Bld.,
YangJae-dong,
Seocho-gu,
Seoul, (zipcode: 137-891)
Phone: (+82) (0)2 574-6300

Kyrgyzstan

Alye Maki
av. Moladaya Guardir J 3
720014
Bishkek

Latvia

Husqvarna Latvija SIA
Ulbrokas 19A
LV-1021 Rīga
info@gardena.lv

Lithuania

UAB Husqvarna Lietuva
Ateities pl. 77C
LT-52104 Kaunas
info@gardena.lt

Luxembourg

Magasins Jules Neuberger
39, rue Jacques Stas
Luxembourg-Gasperich 2549
Case Postale No. 12
Luxembourg 2010
Phone: (+352) 40 14 01
api@neuberger.lu

Mexico

AFOSA
Av. Lopez Mateos Sur # 5019
Col. La Calma 45070
Zapopan, Jalisco
Mexico
Phone: (+52) 33 3818-3434
icornejo@afosa.com.mx

Moldova

Convel S.R.L.
290A Muncesti Str.
2002 Chisinau

Netherlands

Husqvarna Nederland B.V.
GARDENA Division
Postbus 50131
1305 AC ALMERE
Phone: (+31) 36 521 00 10
info@gardena.nl

Neth. Antilles

Jonka Enterprises N.V.
Sta. Rosa Weg 196
P.O. Box 8200
Curaçao
Phone: (+599) 9 767 66 55
pgm@jonka.com

New Zealand

Husqvarna New Zealand Ltd.
PO Box 76-437
Manukau City 2241
Phone: (+64) (0) 9 9202410
support.nz@husqvarna.co.nz

Norway

Husqvarna Norge AS
Gardena Division
Trøskenveien 36
1708 Sarpsborg
info@gardena.no

Peru

Husqvarna Perú S.A.
Jr. Ramón Cárcamo 710
Lima 1
Tel: (+51) 1 3320400 ext. 416
juan.remuzgo@
husqvarna.com

Poland

Husqvarna
Poland Spółka z o.o.
ul. Wysockiego 15 b
03-371 Warszawa
Phone: (+48) 22 330 96 00
gardena@husqvarna.com.pl

Portugal

Husqvarna Portugal, SA
Lagoa - Albarraque
2635 - 595 Rio de Mouro
Tel.: (+351) 21 922 85 30
Fax : (+351) 21 922 85 36
info@gardena.pt

Romania

Madex International Srl
Soseaua Odaii 117-123,
RO 013603 București, S1
Phone: (+40) 21 352.76.03
madex@ines.ro

Russia / Россия

ООО „Хускварна“
141400, Московская обл.,
г. Химки,
улица Ленинградская,
владение 39, стр.6
Бизнес Центр
„Химки Бизнес Парк“,
помещение ОВ02_04
http://www.gardena.ru

Serbia

Domel d.o.o.
Autoput za Novi Sad bb
11 273 Belgrade
Phone: (+381) 1 18 48 88 12
miroslav.jejina@domel.rs

Singapore

Hy-Ray PRIVATE LIMITED
40 Jalan Pemimpin
#02-08 Tat Ann Building
Singapore 577185
Phone: (+65) 6253 2277
shiyiing@hyray.com.sg

Slovak Republic

Husqvarna Česko s.r.o.
Türkova 2319/5b
149 00 Praha 4 – Chodov
Bezplatná infolinka:
800 154 044
servis@sk.husqvarna.com

Slovenia

Husqvarna Austria GmbH
Industriezeile 36
4010 Linz
Tel.: (+43) 732 77 01 01-485
service.gardena@
husqvarnagroup.com

South Africa

Husqvarna
South Africa (Pty) Ltd
Postnet Suite 250
Private Bag X6,
Cascades, 3202
South Africa
Phone: (+27) 33 846 9700
info@gardena.co.za

Spain

Husqvarna España S.A.
Calle de Rivas nº 10
28052 Madrid
Phone: (+34) 91 708 05 00
atencioncliente@gardena.es

Suriname

Agrofix n.v.
Verlengde Hogestraat #22
Phone: (+597) 472426
agrofix@sr.net
Pobox : 2006
Paramaribo
Suriname – South America

Sweden

Husqvarna AB
Gardena Division
S-561 82 Husqvarna
Gardenaorder@husqvarna.se

Switzerland / Schweiz

Husqvarna Schweiz AG
Consumer Products
Industriestrasse 10
5506 Mägenwil
Phone: (+41) (0) 62 887 37 90
info@gardena.ch

Turkey

Dost Bahçe Diş Ticaret
Müessesilik A.Ş
Yunus Mah. Adil Sok. No:3
Ic Kapi No: 1 Kartal
34873 Istanbul
Phone: (+90) 216 38 93 939
info@dostbahce.com.tr

Ukraine / Україна

ТОВ «Хускварна Україна»
вул. Васильківська, 34,
офіс 204-г
03022, м. Київ
Тел. (+38) 044 498 39 02
info@gardena.ua

Uruguay

FELI SA
Entre Rios 1083 CP 11800
Montevideo – Uruguay
Tel: (+598) 22 03 18 44
info@felisa.com.uy

Venezuela

Corporación Casa y Jardín C.A.
Av. Caroní, Edif. Trezmen, PB.
Colinas de Bello Monte.
1050 Caracas.
Tlf: (+58) 212 992 33 22
info@casayjardin.net.ve

8881-20.960.05/0918

© GARDENA
Manufacturing GmbH
D-89070 Ulm
http://www.gardena.com