

9 V
Art. 1251

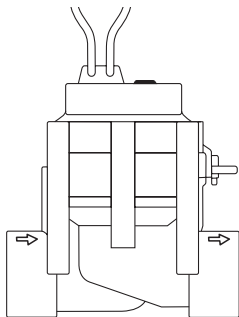

24 V
Art. 1278

DE Betriebsanleitung
Bewässerungsventil

EN Operator's manual
Irrigation Valve

FR Mode d'emploi
Electrovanne

NL Gebruiksaanwijzing
Beregeningsventiel

SV Bruksanvisning
Ventil

DA Brugsvejledning
Vandingsventil

FI Käyttöohje
Kasteluventtiili

NO Bruksanvisning
Vanningsventil

IT Istruzioni per l'uso
Valvola cordless

ES Instrucciones de empleo
Válvula de riego

PT Manual de instruções
Válvula de Irrigação

RO Instrucțiuni de utilizare
Electrovalvă

TR Kullanma Kılavuzu
Solenoid vana

DE

EN

FR

NL

SV

DA

FI

NO

IT

ES

PT

RO

TR

9 V

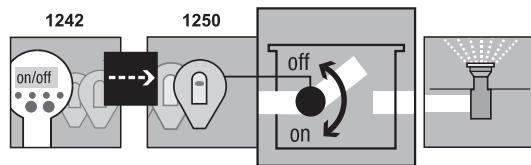

I1

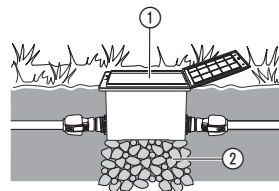

24 V

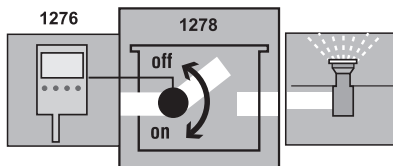

I2

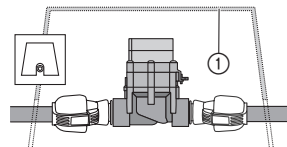

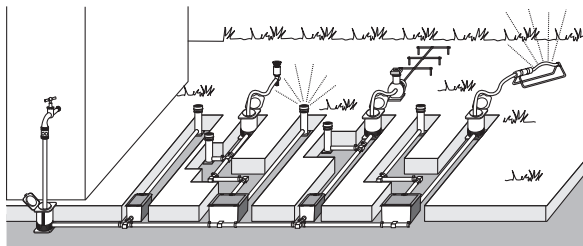
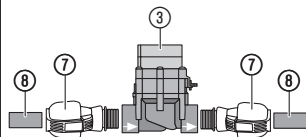
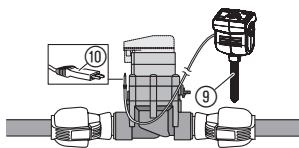
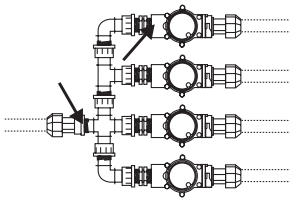
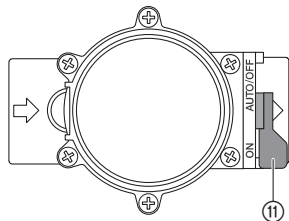
I3**I4****I5****I6****O1**

GARDENA Irrigation Valve

1. SAFETY	13
2. INITIAL OPERATION	14
3. OPERATION	15
4. STORAGE	16
5. TROUBLESHOOTING	17
6. TECHNICAL DATA	17
7. SERVICE/WARRANTY	18

Original instructions.



For safety reasons, children and young people under 16 as well as anyone who is not familiar with these operating instructions should not use the product. Persons with reduced physical or mental abilities may use the product only if they are supervised or instructed by a responsible person. Children must be supervised to ensure that they do not play with the product. Never operate the product when you are tired, ill or under the influence of alcohol, drugs or medicine.

Intended use:

The Irrigation Valves are intended solely for outdoor use for fully automatic control of individual irrigation systems. It is a benefit to arrange a watering system into separate sections in case of varying watering needs for different plant areas or if there is insuffi-

cient water available for simultaneous operation of the entire watering system.

The Irrigation Valve is installed upstream in the watering system (e.g. Pop-up Sprinklers; Micro-Drip-System), for example, in the ground.

Please note:
Compliance with the enclosed operating instructions provided by GARDENA is a prerequisite for proper use of the Irrigation Valve.

Fig. 9 V:

The Irrigation Valve **1251** forms part of an irrigation system in conjunction with the Programming Unit **1242** and the Control Unit **1250**.

Fig. 24 V:

The Irrigation Valve **1278** forms part of an irrigation system in conjunction with the Watering Controller **1276**.



The Irrigation Valve must only be used in conjunction with the – 9 V Control Units; Radio Receivers/24 V Watering Controller – approved by GARDENA.

1. SAFETY

IMPORTANT!

Read the operator's manual carefully before use and keep for future reference.

→ Please observe the notes on safety in the operating instructions.

9 V and 24 V products are not interchangeable.

Blocking the Irrigation Valve:

→ **In the case of dirty water, the GARDENA Central Filter Art. 1510 must be installed upstream in the watering system.**

Water pressure:

The function of your watering system depends on the available water pressure. Therefore, care should be taken not to overlap watering cycles of the various watering circuits and to ensure that the watering circuits you have planned will be supplied with sufficient water at an adequate pressure.

Please refer to the planning instructions in the special brochure entitled "Watering Systems – Sprinkler System Planning Guide" available from GARDENA.

DANGER!

This product makes an electromagnetic field while it operates. This field may under some conditions interfere with active or passive medical implants. To decrease the risk of conditions that can possibly injure or kill, we recommend persons with medical implants to speak with their physician and the medical implant manufacturer before you operate the product.

DANGER!

Small parts can be easily swallowed. There is also a risk that the polybag can suffocate toddlers. Keep toddlers away when you assemble the product.

2. INITIAL OPERATION

If the Irrigation Valve is installed below ground level, it must be installed in a sturdy and step-proof valve mount ① (valve box) e.g. **GARDENA Art. 1254/1255/1290/1292**.

Install the valve mount [Fig. I1/I2]:

1. Draw up a plan (see e.g. Fig. I3).
Additional information is provided in the GARDENA Sprinkler System Planning Guide which is available from your GARDENA dealer.
2. For underground installation, place a layer of coarse gravel ② underneath the valve mount ①.
This ensures proper drainage of the box.
3. Install the valve box with the top edge of the box at ground level.
This avoids damage when mowing the lawn.

Please refer to the relevant operating instructions for information on how to install the Irrigation Valves in GARDENA Valve Boxes V1 and V3.

Installing the Irrigation Valve without a Valve Box [Fig. I4]:

The integrated solenoid valve works only correctly with the Irrigation Valve connected in flow direction.



CAUTION! Flow direction!

→ Pay attention to the flow direction (arrows) when installing the Irrigation Valve ③.

→ Seal the screw connections with PTFE sealing tape, **Art. 7219**.

Connecting GARDENA Connecting pipes ⑧ (2700/2701/2704/2705/2718) or other commercially available connecting pipes:

1. Screw a **GARDENA Connector ⑦ 2763** (1" = 25 mm)/ **2769** (5/4" = 32 mm) into the Irrigation Valve ③.
2. Connect the GARDENA connecting pipes ⑧ or other commercially available connecting pipes (25 mm/32 mm).

Connect Soil Moisture Sensor or Rain Sensor electronic (optional) [Fig. I5]:

In conjunction with the programmed watering time, the moisture level of the soil or the natural precipitation can be taken into account for each Irrigation Valve.

When a sufficient moisture content of the soil is reached, a programme may be interrupted or activation of a programme may be suppressed.

1. Place the Soil Moisture Sensor ⑨ **in** the area to be irrigated
 – or –
 the Rain Sensor electronic (if necessary with an extension cable) **outside** of the area to be irrigated.

2. **9 V:** Plug the connector ⑩ into the sensor socket of the Control Unit.

24 V: Insert plug ⑩ in the sensor connection of the Watering Control System **Art. 1276** (see Operating Instructions Art. 1276).

Conventional installation [Fig. I6]:

If using **Art. 2750/2751/2752/2753/2755** the points marked with an arrow must be sealed with sealing tape (**e.g. Art. No. 7219**).

3. OPERATION

Adjusting valve control [Fig. O1]:

Fully Automatic Control:

- Set selection lever ⑪ to **“AUTO/OFF”**.
Programme-controlled water flow to the watering system according to the programming in the Control Unit/Radio Receiver.

An automatically opened valve cannot be closed manually.

Manual Control:

- Set selection lever ⑪ to **“ON”**.
Permanent water flow, independent of the programming.

4. STORAGE

To put into storage/Winter storage:

GARDENA Irrigation Valves are intended for outdoor use and are only frost-proof to a limited extent. The only way to protect your Irrigation Valves completely is to remove the valves before the frosty season begins. Alternatively, you can drain the pipeline system upstream and downstream of the Irrigation Valve.

Emptying the pipeline system UPSTREAM of the valve [Fig. O1]:

1. Turn off the tap and disconnect the hose between the tap and the **GARDENA Water Connection Point Art. 2722/ Art. 2795**.
This allows the air to flow freely and the supply line can be drained using the drain valve integrated in the Connecting Point. This requires that the Connecting Point be installed deeper in the ground than the Irrigation Valve.
2. If the watering system is directly connected to the water tap, turn off the water supply and open the venting tap.
3. Set the selection lever (11) of all valves to the **“ON”** position.
4. If you are using the GARDENA Valve Box V3, make sure you open the integrated drain cap.

Emptying the pipeline system DOWNSTREAM of the valve:

Requirement: The Drainage Valve must be installed deeper than or at the same depth as the Irrigation Valve.

→ Install a GARDENA Drainage Valve **Art. 2760** immediately after the valve.

The system is drained automatically via the the GARDENA Drainage Valve.

→ If neither of these requirements is fulfilled, the valve must be removed and stored in a place safe from frost.

Disposal:

(in accordance with RL2012/19/EC)

The product must not be disposed of to normal household waste. It must be disposed of in line with local environmental regulations.

Important! Dispose of the product through or via your municipal recycling collection centre.



5. TROUBLESHOOTING

Problem	Possible Cause	Remedy
Solenoid valve does not open, no water flow	No water supply.	→ Turn on water supply.
	Control Unit/Radio Receiver/Watering Controller not connected correctly to Irrigation Valve.	→ Connect Control Unit/Radio Receiver/Watering Controller correctly to Irrigation Valve.
Solenoid valve does not close, continuous water flow	Solenoid valve installed opposite to flow direction.	→ Turn solenoid valve (observe the flow direction).
	Selection lever (ii) set to "ON".	→ Set selection lever (ii) to "AUTO/OFF".



NOTE: For any other malfunctions please contact the GARDENA service department. Repairs must only be done by GARDENA service departments or specialist dealers approved by GARDENA.

6. TECHNICAL DATA

<i>Solenoid Valve</i>	Unit	Value 9 V (Art. 1251)	Value 24 V (Art. 1278)
Voltage	V	9 (DC)	24 (AC)
Operating pressure	bar	0,5 to 12	0,5 to 12
Flow medium		clean fresh water	clean fresh water
Max. water temperature	°C	40	40

7. SERVICE/WARRANTY

Service:

Please contact the address on the back page.

Warranty:

In the event of a warranty claim, no charge is levied to you for the services provided.

GARDENA Manufacturing GmbH offers a 2-year warranty for this product (from the date of purchase) if the product has been used exclusively for private purposes. This manufacturer's warranty does not apply to used products purchased from a secondary market. This warranty includes all significant defects of the product that can be proved to be material or manufacturing faults. This warranty is fulfilled by supplying a fully functional replacement product or by repairing the faulty product sent to us free of charge; we reserve the right to choose between these options. This service is subject to the following provisions:

- The product was used for its intended purpose as per the recommendations in the operating instructions.

- Neither the purchaser nor a third party has attempted to repair the product.
- Only original GARDENA spare and wear parts were used.

Normal wear and tear of parts and components, optical changes, as well as wear parts and consumables, are excluded from the warranty.

This manufacturer's warranty does not affect warranty entitlements against the dealer/retailer.

If problems arise with this product, please contact our Service department. In the event of a warranty claim, please send the defective product together with a copy of the purchase receipt and a description of the defect, sufficiently stamped, to the GARDENA service address on the back page.

Consumables:

Faults with the Irrigation Valve caused by incorrectly installed batteries or leaking batteries in the Control Unit/Radio Receiver are not covered by the guarantee.

Bild Nr. Picture No.	Ersatzteil-Nr. Spare Part No.	Bezeichnung Bewässerungsventil 9 V/1" Art. -Nr. 1251	Description Watering Valve 9 V/1" Art. No. 1251
19 – 36	1251-00.500.00	Bew. Ventil 9 V/ 1" (= Art.1251)	Watering valve 9 V/ 1" (=Art.1251)
19	1815-00.610.27	Steuerdüse, rot	Control nozzle, red
20	1251-00.500.26	Ventildeckel	Valve cover
21	913-00.680.01	O-Ring 7,5 x 2	O-Ring 7,5 x 2
22 + 21	1251-00.701.00	Küicken, vollst.	Mixer dial, cpl.
23	1672-00.600.11	O-Ring 24 x 2	O-Ring 24 x 2
24	1174-00.617.00	Magnetplatte, vollst.	Magnetic plate, cpl.
25	1174-00.610.11	Druckfeder, klein	Pressure spring, small
26	1251-00.510.00	Elektromagnet, vollst.	Electric magnet, cpl.
27	1174-00.610.07	Blechschraube 3,5 x 25-F-H	Sheet metal screw 3,5 x 25-F-H
28	1251-00.500.21	Blechschraube 4,2 x 60	Sheet metal screw 4,2 x 60 (6 x)
29	1174-00.610.08	Druckfeder, gross	Pressure spring, large
30 – 34	1251-00.520.00	Membrane, vollst.	Diaphragm
35	1251-00.500.11	Stützring	Support ring
36	1251-00.500.06	Ventilkörper	Valve body
	1251-00.540.00	Feinfilter	Fine filter

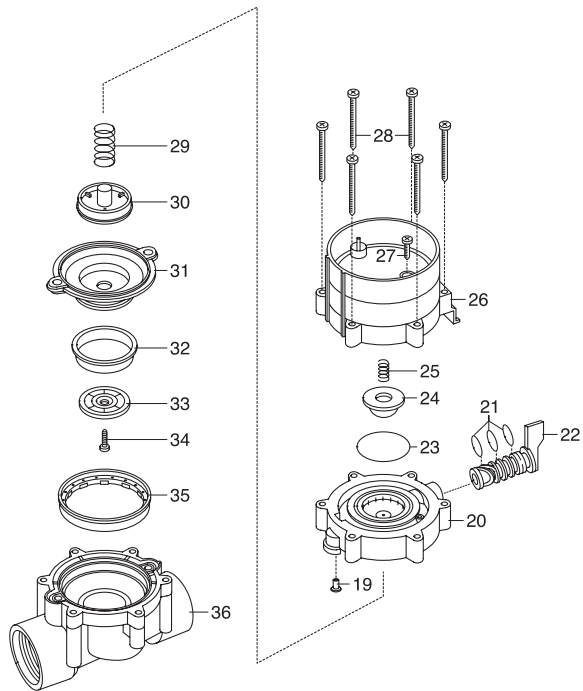

DE Produkthaftung

Wir weisen ausdrücklich darauf hin, dass wir in Übereinstimmung mit dem Produkthaftungsgesetz nicht für Schäden haften, die durch unsere Produkte entstehen, wenn diese unsachgemäß und nicht durch einen von uns autorisierten Servicepartner repariert wurden oder wenn keine Original GARDENA Teile oder von uns zugelassene Teile verwendet wurden.

SV Produktansvar

I enlighet med tyska produktansvarslagar förklarar vi härmed uttryckligen att vi inte åtar oss något ansvar för skador som orsakas av våra produkter där produkterna inte har genomgått korrekt reparation från en GARDENA-godkänd servicepartner eller där originaldelar från GARDENA eller delar godkända av GARDENA inte använts.

EN Product liability

In accordance with the German Product Liability Act, we hereby expressly declare that we accept no liability for damage incurred from our products where said products have not been properly repaired by a GARDENA-approved service partner or where original GARDENA parts or parts authorised by GARDENA were not used.

DA Produktansvar

I overensstemmelse med den tyske produktansvarslov erklærer vi hermed udtrykkeligt, at vi ikke påtager os noget ansvar for skader på vores produkter, hvis de pågældende produkter ikke er blevet repareret korrekt af en GARDENA-godkendt servicepartner, eller hvor der ikke er brugt originale GARDENA-reservedele eller godkendte reservedele fra GARDENA.

FR Responsabilité

Conformément à la loi relative à la responsabilité du fait des produits défectueux, nous déclarons expressément par la présente que nous déclinons toute responsabilité pour les dommages résultant de nos produits, si lesdits produits n'ont pas été correctement réparés par un partenaire d'entretien agréé GARDENA ou si des pièces d'origine GARDENA ou des pièces agréées GARDENA n'ont pas été utilisées.

FI Tuotevastuu

Saksan tuotevastuulain mukaisesti emme ole vastuussa laitteiden vaurioista, jos korjauksia ei ole tehnyt GARDENAn hyväksymä huoltoliike tai jos niiden syynä on muiden kuin alkuperäisten GARDENA-varaosien tai GARDENAn hyväksymien varaosien käyttö.

NL Productaansprakelijkheid

Conform de Duitse wet inzake productaansprakelijkheid verklaren wij hierbij uitdrukkelijk dat wij geen aansprakelijkheid aanvaarden voor schade ontstaan uit onze producten waarbij deze producten niet zijn gerepareerd door een GARDENA-erkende servicepartner of waarbij geen originele GARDENA-onderdelen of onderdelen die door GARDENA zijn goedgekeurd zijn gebruikt.

IT Responsabilità del prodotto

In conformità con la Legge tedesca sulla responsabilità del prodotto, con la presente dichiariamo espressamente che decliniamo qualsiasi responsabilità per danni causati dai nostri prodotti qualora non siano stati correttamente riparati presso un partner di assistenza approvato GARDENA o laddove non siano stati utilizzati ricambi originali o autorizzati GARDENA.

ES Responsabilidad sobre el producto

De acuerdo con la Ley de responsabilidad sobre productos alemana, por la presente declaramos expresamente que no aceptamos ningún tipo de responsabilidad por los daños ocasionados por nuestros productos si dichos productos no han sido reparados por un socio de mantenimiento aprobado por GARDENA o si no se han utilizado piezas originales GARDENA o piezas autorizadas por GARDENA.

RO Răspunderea pentru produs

În conformitate cu Legea germană privind răspunderea pentru produs, declaram în mod expres prin prezentul document că nu acceptăm nicio răspundere pentru defecțiunile suferite de produsele noastre atunci când acestea nu au fost reparate în mod corect de un atelier de service partener, aprobat de GARDENA, sau când nu au fost utilizate piese GARDENA originale sau piese autorizate de GARDENA.

PT Responsabilidade pelo produto

De acordo com a lei alemã de responsabilidade pelo produto, declaramos que não nos responsabilizamos por danos causados pelos nossos produtos, caso os tais produtos não tenham sido devidamente reparados por um parceiro de assistência GARDENA aprovado ou se não tiverem sido utilizadas peças GARDENA originais ou peças autorizadas pela GARDENA.

Deutschland / Germany

GARDENA Manufacturing GmbH
Central Service
Hans-Lorenser-Straße 40
D-89079 Ulm
Produktfragen:
(+49) 731 490-123
Reparaturen:
(+49) 731 490-290
service@gardena.com

Albania

COBALT Sh.p.k.
Rr. Siri Kodra
1000 Tirana

Argentina

Husqvarna Argentina S.A.
Av. del Libertador 5954 –
Piso 11 – Torre B
(C1428ARP) Buenos Aires
Phone: (+54) 11 5194 5000
info.gardena@ar.husqvarna.com

Armenia

Garden Land Ltd.
61 Tigran Mets
0005 Yerevan

Australia

Husqvarna Australia Pty. Ltd.
Locked Bag 5
Central Coast BC
NSW 2252
Phone: (+ 61) (0) 2 4352 7400
customer.service@
husqvarna.com.au

Austria / Österreich

Husqvarna Austria GmbH
Industriezeile 36
4010 Linz
Tel.: (+43) 732 77 01 01-485
service.gardena@
husqvarnagroup.com

Azerbaijan

Firm Progress
a. Aliyev Str. 26A
1052 Baku

Belgium

Husqvarna België nv/sa
Gardena Division
Rue Egide Van Ophem 111
1180 Uccle / Ukkel
Tel.: (+32) 2 720 92 12
Mail: info@gardena.be

Bosnia / Herzegovina

SILK TRADE d.o.o.
Industrijska zona Bukva bb
74260 Tešanj

Brazil

Husqvarna do Brasil Ltda
Av. Francisco Matarazzo,
1400 – 19º andar
São Paulo – SP
CEP: 05001-903
Tel: 0800-112252
marketing.br.husqvarna@
husqvarna.com.br

Bulgaria

AGROLAND България АД
бул. 8 Декември, № 13
Офис 5
1700 Студентски град
София
Tel.: (+359) 24666910
info@agroland.eu

Canada / USA

GARDENA Canada Ltd.
100 Summerlea Road
Brampton, Ontario L6T 4X3
Phone: (+1) 905 792 93 30
info@gardenacanada.com

Chile

Maquinarias Agroforestales
Ltda. (Maga Ltda.)
Santiago, Chile
Avda. Chesterton
8355 comuna Las Condes
Phone: (+56) 2 202 4417
Dalton@maga.cl
Zipcode: 7560330

China

Husqvarna (Shanghai)
Management Co., Ltd.
富世华 (上海) 管理有限公司
3F, Benq Square B,
No207, Song Hong Rd.,
Chang Ning District,
Shanghai, PRC. 200335
上海市长宁区淞虹路207号明
基广场B座3楼, 邮编: 200335

Colombia

Husqvarna Colombia S.A.
Calle 18 No. 68 D-31, zona
Industrial de Montevideo
Bogotá, Cundinamarca
Tel. 571 2922700 ext. 105
jairo.salazar@husqvarna.com.co

Costa Rica

Compañia Exim
Euroiberamericana S.A.
Los Colegios, Moravia,
200 metros al Sur del Colegio
Saint Francis – San José
Phone: (+506) 297 68 83
exim_euro@racsa.co.cr

Croatia

Husqvarna Austria GmbH
Industriezeile 36
4010 Linz
Tel.: (+43) 732 77 01 01-485
service.gardena@
husqvarnagroup.com

Cyprus

Med Marketing
17 Digeni Akrita Ave
P.O. Box 27017
1641 Nicosia

Czech Republic

Husqvarna Česko s.r.o.
Türkova 2319/5b
149 00 Praha 4 – Chodov
Bezplatná infolinka :
800 100 425
servis@cz.husqvarna.com

Denmark

GARDENA DANMARK
Lejrevej 19, st.
3500 Værløse
Tlf.: (+45) 70264770
husqvarna@husqvarna.dk
www.gardena.com / dk

Dominican Republic

BOSQUESA, S.R.L
Carretera Santiago Licey
Km. 5 ½
Esquina Copal II.
Santiago
Dominican Republic
Phone: (+809) 736-0333
joserbosquesa@claro.net.do

Ecuador

Husqvarna Ecuador S.A.
Arupos E1-181 y 10 de
Agosto Quito, Pichincha
Tel. (+593) 22800739
francisco.jacome@
husqvarna.com.ec

Estonia

Husqvarna Eesti OÜ
Valdeku 132
EE-11216 Tallinn
info@gardena.ee

Finland

Oy Husqvarna Ab
Gardena Division
Lautatarhankatu 8 B / PL 3
00581 HELSINKI
www.gardena.fi

France

Husqvarna France
9/11 Allée des pierres mayettes
92635 Gennevilliers Cedex
France
http : //www.gardena.com/ fr
N° AZUR: 0 810 00 78 23
(Prix d'un appel local)

Georgia

Transporter LLC
8/57 Bellashvili street
0159 Tbilisi, Georgia
Phone: (+995) 322 14 71 71

Great Britain

Husqvarna UK Ltd
Preston Road
Aycliffe Industrial Park
Newton Aycliffe
County Durham
DL5 6UP
info.gardena@husqvarna.co.uk

Greece

Π.ΠΑΠΑΔΟΠΟΥΛΟΣ ΑΕΒΕ
Λεωφ. Αθηνών 92
Αθήνα
T.K.104 42
Ελλάδα
Τηλ. (+30) 210 5193 100
info@papadopoulos.com.gr

Hungary

Husqvarna Magyarország Kft.
Ezred u. 1-3
1044 Budapest
Telefon: (+36) 1 251-4161
vevoszolgalat.husqvarna@
husqvarna.hu

Iceland

Ó. Johnson & Kaaber
Tunguhsali 1
110 Reykjavik
ooj@ojk.is

Ireland

Husqvarna UK Ltd
Preston Road
Aycliffe Industrial Park
Newton Aycliffe
County Durham
DL5 6UP
info.gardena@husqvarna.co.uk

Italy

Husqvarna Italia S.p.A.
Via Santa Vecchia 15
23868 VALMADRERA (LC)
Phone: (+39) 0341.203.111
assistenza.italia@it.husqvarna.com

Japan
KAKIUCHI Co. Ltd.
Sumitomo Realty &
Development Kojimachi
BLDG., 8F
5-1 Nibanncyo
Chiyoda-ku
Tokyo 102-0084
Phone: (+81) 33 264 4721
m_ishihara@kaku-ichi.co.jp

Kazakhstan
LAMED Ltd.
155/1, Tazhibayevoi Str.
050060 Almaty
IP Schmidt
Abayavenue 3B
110 005 Kostanay

Korea
Kyung Jin Trading CO.,LTD.
107-4, SunDuk Bid.,
YangJae-dong,
Seocho-gu,
Seoul, (zipcode: 137-891)
Phone: (+82) (0)2 574-6300

Kyrgyzstan
Alye Maki
av. Moladaya Guardir J 3
720014
Bishkek

Latvia
Husqvarna Latvija SIA
Ulbrokas 19A
LV-1021 Riga
info@gardena.lv

Lithuania
UAB Husqvarna Lietuva
Ateities pl. 77C
LT-52104 Kaunas
info@gardena.lt

Luxembourg
Magasins Jules Neuberger
39, rue Jacques Stas
Luxembourg-Gasperich 2549
Case Postale No. 12
Luxembourg 2010
Phone: (+352) 40 14 01
api@neuberger.lu

Mexico
AFOSA
Av. Lopez Mateos Sur # 5019
Col. La Calma 45070
Zapopan, Jalisco, Mexico
Phone: (+52) 33 3818-3434
icornejo@afosa.com.mx

Moldova
Convel S.R.L.
290A Muncesti Str.
2002 Chisinau

Netherlands
Husqvarna Nederland B.V.
GARDENA Division
Postbus 50131
1305 AC ALMERE
Phone: (+31) 36 521 00 10
info@gardena.nl

Neth. Antilles
Jonka Enterprises N.V.
Sta. Rosa Weg 196
P.O. Box 8200
Curaçao
Phone: (+599) 9 767 66 55
pgm@jonka.com

New Zealand
Husqvarna New Zealand Ltd.
PO Box 76-437
Manukau City 2241
Phone: (+64) (0) 9 9202410
support.nz@husqvarna.co.nz

Norway
Husqvarna Norge AS
Gardena Division
Traskemeveien 36
1708 Sarpsborg
info@gardena.no

Peru
Husqvarna Perú S.A.
Jr. Ramón Cárcamo 710
Lima 1
Tel: (+51) 1 3320400 ext. 416
juan.remuzgo@husqvarna.com

Poland
Husqvarna
Poland Spółka z o.o.
ul. Wyszockiego 15 b
03-371 Warszawa
Phone: (+48) 22 330 96 00
gardena@husqvarna.com.pl

Portugal
Husqvarna Portugal, SA
Lagoa - Albarraque
2635 - 595 Rio de Mouro
Tel.: (+351) 21 922 85 30
Fax : (+351) 21 922 85 36
info@gardena.pt

Romania
Madex International Srl
Soseaua Odaii 117 - 123,
RO 013603 București, S1
Phone: (+40) 21 352.76.03
madex@ines.ro

Russia / Россия
ООО „Хускварна“
141400, Московская обл.,
г. Химки,
улица Ленинградская,
владение 39, стр.6
Бизнес Центр
„Химки Бизнес Парк“,
помещение 0B02_04
http://www.gardena.ru

Serbia
Domel d.o.o.
Autoput za Novi Sad bb
11273 Belgrade
Phone: (+381) 1 18 48 88 12
miroslav.jejina@domel.rs

Singapore
Hy-Ray PRIVATE LIMITED
40 Jalan Pemimpin
#02-08 Tat Ann Building
Singapore 577185
Phone: (+65) 6253 2277
shiyang@hyray.com.sg

Slovak Republic
Husqvarna Cesko s.r.o.
Türkova 2319/5b
149 00 Praha 4 – Chodov
Bezplatná infolinka:
800 154 044
servis@sk.husqvarna.com

Slovenia
Husqvarna Austria GmbH
Industriezeile 36
4010 Linz
Tel.: (+43) 732 77 01 01-485
service.gardena@
husqvarnagroup.com

South Africa
Husqvarna
South Africa (Pty) Ltd
Postnet Suite 250
Private Bag X6,
Cascades, 3202
South Africa
Phone: (+27) 33 846 9700
info@gardena.co.za

Spain
Husqvarna España S.A.
Calle de Rivas nº 10
28052 Madrid
Phone: (+34) 91 708 05 00
atencioncliente@gardena.es

Suriname
Agrofix n.v.
Verlengde Hogestraat #22
Phone: (+597) 472426
agrofix@sr.net
Pobox : 2006
Paramaribo
Suriname – South America

Sweden
Husqvarna AB
Gardena Division
S-561 82 Huskvarna
gardenaorder@husqvarna.se

Switzerland / Schweiz
Husqvarna Schweiz AG
Consumer Products
Industriestrasse 10
5506 Mägenwil
Phone: (+41) (0) 62 887 37 90
info@gardena.ch

Turkey
Dost Bahçe Diş Ticaret
Mümesillik A.Ş
Yunus Mah. Adil Sok. No: 3
İc Kapı No: 1 Kartal
34873 İstanbul
Phone: (+90) 216 38 93 939
info@dostbahce.com.tr

Ukraine / Україна
ТОВ «Хускварна Україна»
вул. Васильківська, 34,
офіс 204-г
03022, м. Київ
Тел. (+38) 044 498 39 02
info@gardena.ua

Uruguay
FEL SA
Entre Rios 1083 CP 11800
Montevideo – Uruguay
Tel : (+598) 22 03 18 44
info@felisa.com.uy

Venezuela
Corporación Casa y Jardín C.A.
Av. Caroní, Edif. Trezmen, PB.
Colinas de Bello Monte.
1050 Caracas.
Tlf : (+58) 212 992 33 22
info@casayjardin.net.ve

1251-20.960.21/0219
© GARDENA Manufacturing GmbH
D-89070 Ulm
http://www.gardena.com