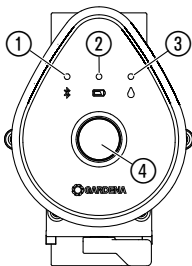
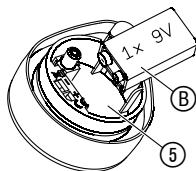
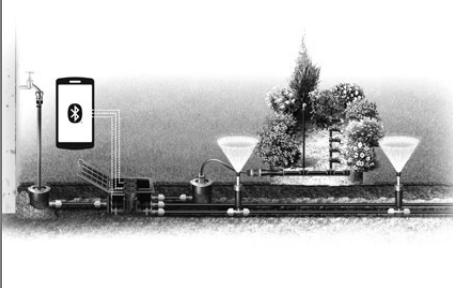
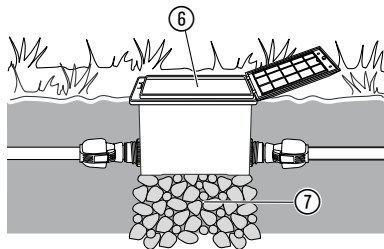
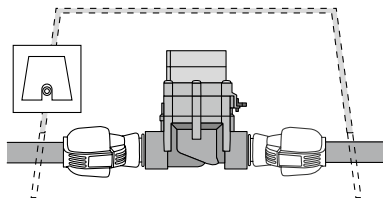
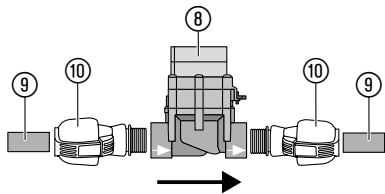
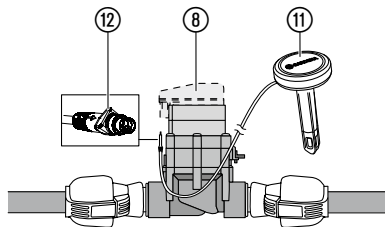
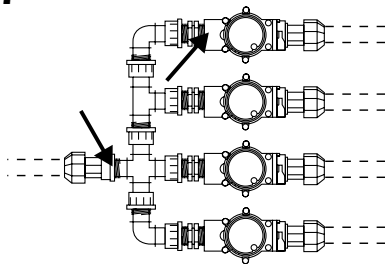
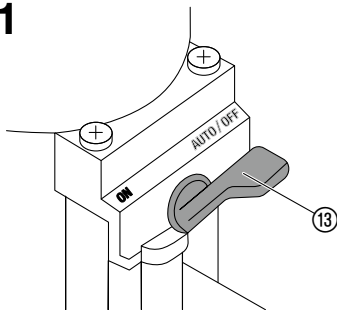

**EN Operation Instructions**  
Irrigation Valve 9 V Bluetooth®

---

Art. 1285

**F1****I1****I2****I3****I4**

**I5****I6****I7****O1**

# GARDENA Irrigation Valve 9 V Bluetooth®

1. SAFETY . . . . .	15
2. FUNCTION . . . . .	17
3. INITIAL OPERATION . . . . .	17
4. OPERATION . . . . .	19
5. MAINTENANCE . . . . .	20
6. STORAGE . . . . .	20
7. TROUBLESHOOTING . . . . .	21
8. TECHNICAL DATA . . . . .	22
9. ACCESSORIES . . . . .	23
10. SERVICE/WARRANTY . . . . .	24

or instructed by a responsible person. Children must be supervised to ensure that they do not play with the product. Never operate the product when you are tired, ill or under the influence of alcohol, drugs or medicine.

## **Intended use:**

The **GARDENA Irrigation Valve** is intended solely for outdoor use for fully automatic control of individual irrigation systems. It is a benefit to arrange a watering system into separate sections in case of varying watering needs for different plant areas or if there is insufficient water available for simultaneous operation of the entire watering system. The Irrigation Valve is installed upstream in the watering system (e. g. Pop-up Sprinklers; Micro-Drip-System), for example, in the ground.

The **Irrigation Valve Bluetooth® Art 1285** forms part of an irrigation system in conjunction with the **Bluetooth® App**.

## **Translation of the original instructions.**



For safety reasons, children and young people under 16 as well as anyone who is not familiar with these operating instructions should not use the product. Persons with reduced physical or mental abilities may use the product only if they are supervised

## **1. SAFETY**

### **IMPORTANT!**

**Read the operator's manual carefully before use and keep for future reference.**

### **Battery:**

**To ensure the Water Control runs safely, only a 9 V alkaline manganese battery (alkaline) type IEC 6LR61 must be used!**

**CAUTION!**

**Rechargeable batteries should not be used, otherwise the operating period of 1 year cannot be guaranteed!**

In order to stop the Water Control from failing because of a weak battery if you are away for a long time, the battery must be replaced when the battery symbol illuminates yellow.

Regularly examine the batteries for damage.

Do not use damaged batteries.

Keep damaged batteries out of the reach of children.

**Setting up:****Blocking the Irrigation Valve:**

→ **In the case of dirty water, a GARDENA Central Filter Art. 1510 must be installed upstream in the watering system.**

**Water pressure:**

The function of your watering system depends on the available water pressure. Therefore, care should be taken not to overlap watering cycles of the various watering

circuits and to ensure that the watering circuits you have planned will be supplied with sufficient water at an adequate pressure. Please refer to the planning instructions in the GARDENA Brochure "Automatic Irrigation".

**CAUTION!**

If the control section is removed when the valve is open, the valve remains open until the control section is reattached.

**DANGER! Cardiac arrest!**

**This product makes an electromagnetic field while it operates. This field may under some conditions interfere with active or passive medical implants. To decrease the risk of conditions that can possibly injure or kill, we recommend persons with medical implants to speak with their physician and the medical implant manufacturer before you operate the product.**

**DANGER! Risk of suffocation!**

**Small parts can be easily swallowed. There is also a risk that the polybag can suffocate toddlers. Keep toddlers away when you assemble the product.**

## 2. FUNCTION

---

### **Irrigation Valve:**

The **GARDENA Irrigation Valve 9 V Bluetooth®** is configured automatically with the **GARDENA Bluetooth® App** and consists of a valve and a control unit.

The Irrigation Valve carries out watering automatically according to the set program and can therefore also be used during holidays.

### **Controls/Display [Fig. F1]:**

- ① **LED Connection display/Signal:**  
**Blue flashing for 3 min.:** While connection  
**Blue lightning for 10 sec:** Successfully connected
- ② **LED Battery display:**  
**Green lightning:** Capacity up to 1 year  
**Yellow lightning:** Capacity min. 4 weeks

- Red flashing:** Capacity max. 4 weeks
- Red lightning:** Battery flat, valve no longer opens. A valve opened will also close again if the battery is flat.

The battery display is reset when the batteries are changed.

- ③ **LED Active watering:**  
**Green lightning for 10 seconds.**
- ④ **Man. Button:**  
A single push on the Man. Button activates the status request and the battery status is displayed for 10 sec. A second push activates manual watering.

## 3. INITIAL OPERATION

---

### **To operate with the GARDENA Bluetooth® App:**

You can use the free **GARDENA Bluetooth® app** to control the **GARDENA Irrigation Valve Bluetooth®** at any time. It can be downloaded from the Apple App Store or from the Google Play Store.

### **Settings of the Irrigation Valve:**

- According to the timings in the Bluetooth® App: Watering start, duration, days
- As required in the Bluetooth® App: Start and finish
- As required on the Irrigation Valve: Start and stop

**To insert the battery [Fig. I1]:**

The battery is not included in the scope of delivery.

The operating period is approx. 1 year. The operating period can vary depending on ambient temperature and transmission frequency.

1. Pull the control unit off the valve.
2. Place the battery ⑧ in the battery compartment ⑤ (note the polarity +/–).

*The connection LED is flashing.*

3. Push the control unit back onto the valve.

**To install the valve mount [Fig. I2/I3/I4]:**

If the Irrigation Valve is installed below ground level, it must be installed in a sturdy and stepproof valve mount ⑥ (valve box), e.g. **GARDENA Art. 1254/1255/1290/1292**.

1. Draw up a plan. Additional information is provided in the GARDENA Brochure “Automatic Irrigation”.
2. For underground installation: Support the valve surround ⑥ for drainage with a coarse gravel pack ⑦.
3. Install the valve box with the top edge of the box at ground level.

*This avoids damage when mowing the lawn.*

Please refer to the relevant operating instruction for information on how to install the Irrigation Valves in GARDENA Valve Boxes V1 and V3.

**To install the Irrigation Valve without a Valve Box [Fig. I5]:**

**CAUTION! Flow direction!**

→ **When installing the Irrigation Valve ⑧, pay attention to the direction of flow (arrows) to make sure it works properly.**

1. Seal the screw connections with the **GARDENA PTFE sealing tape, Art. 7219**.

**Connecting GARDENA Connecting pipes ⑨ (2700/2701/2718) or other commercially available connecting pipes:**

2. Screw the **GARDENA Connectors ⑩ Art. 2763** into the Irrigation Valve ⑧.
3. Connect the **GARDENA Connecting pipes ⑨** or other commercially available connecting pipes (25 mm).

**To connect the Soil Moisture Sensor (optional) [Fig. I6]:**

In addition to time-dependent control, it is also possible to include soil moisture.

If the soil moisture is sufficient, irrigation is stopped or skipped.

1. Place the Soil Moisture Sensor ⑪ in the area to be irrigated.
2. Plug the connector ⑫ into the sensor socket of the Control Unit ⑧.

**Conventional installation [Fig. I7]:**

If using **Art. 2750/2751/2752/2753/2755** the points marked with an arrow must be sealed with sealing tape (e.g. **Art. 7219**).

## 4. OPERATION

---

**To adjust the valve control [Fig. O1]:****Fully Automatic Control:**

Time-controlled irrigation with the **GARDENA Bluetooth® App**.

An automatically opened valve can be closed manually via the **Man. Button** on the valve or in the App.

→ Set the selection lever (13) to **AUTO/OFF**.

**Manual Control:**

Permanent water flow, independent of the time control.

→ Set the selection lever (13) to **ON**.

**Factory Reset [Fig. F1/I1]:**

The Irrigation Valve 9 V Bluetooth® will be reset to the factory settings.

1. Remove the battery (8).
2. Push and hold the **Man. Button** (4) and place the battery (8) in the battery compartment (5) (note the polarity +/-).
3. Push and hold the **Man. Button** (4) for another 10 seconds.

*After approx. 10 seconds the factory setting is restored and the connection LED is flashing.*



## 5. MAINTENANCE

*To clean the Irrigation Valve:*



**DANGER! Risk of physical injury!**

**Risk of injury and risk of damage to the product.**

→ Do not clean the product with water or with a water jet (in particular high-pressure water jet).

→ Do not clean with chemicals including petrol or solvents. Some can destroy critical plastic parts.

→ Clean the Irrigation Valve with a soft, damp cloth.

## 6. STORAGE

*To put into storage:*

The product must be stored away from children.

**The GARDENA Irrigation Valve are intended for outdoor use and are only frost-proof to a limited extent. The only way to protect your Irrigation Valves completely is to remove the valves before the frosty season begins. Alternatively, the pipe system can be emptied before and after the Irrigation Valve.**

1. Remove the battery to preserve it (see 3. Initial Operation).
2. Store the Irrigation Valve in a dry, enclosed and frost-free place.

*To empty the pipeline system:*

**To empty the pipeline system UPSTREAM of the valve:**

1. Turn off the tap and disconnect the hose between the tap and the **GARDENA Water Connection Point Art. 2722/Art. 2795**.  
*This allows the air to flow freely.*
2. If the watering system is directly connected to the water tap, turn off the water supply and open the venting tap.
3. Set the selection lever (13) of all valves to the **ON** position.
4. If you are using the GARDENA Valve Box V3, make sure that you open the integrated drain cap.

## To empty the pipeline system **DOWNSTREAM** of the valve:

**Requirement:** The Drainage Valve must be installed deeper than or at the same depth as the Irrigation Valve.

→ Install the **GARDENA Drainage Valve Art. 2760** immediately after the valve.

*The system is drained automatically via the the GARDENA Drainage Valve.*



### **CAUTION!**

**If neither of these requirements is fulfilled, the valve must be removed and stored in a place safe from frost.**

### **Disposal:**

*(in accordance with RL2012/19/EC)*



The product must not be disposed of to normal household waste. It must be disposed of in line with local environmental regulations.

### **IMPORTANT!**

→ Dispose of the product through or via your municipal recycling collection centre.

### **Disposal of the battery:**

The battery may only be disposed of when discharged.

### **IMPORTANT!**

→ Dispose of the battery through or via your municipal recycling collection centre.

## 7. TROUBLESHOOTING

In case of malfunctions you will find the FAQ at this address:

[www.gardena.com/de/bluetooth/faq](http://www.gardena.com/de/bluetooth/faq)

<b>Problem</b>	<b>Possible Cause</b>	<b>Remedy</b>
<b>No LED-display appears</b>	Battery is inserted incorrectly.	→ Batteries inserted incorrectly.
	Battery is completely empty.	→ Replace the battery.

Problem	Possible Cause	Remedy
<b>Irrigation valve does not open, no water flow</b>	No water supply.	→ Turn on the water supply.
	Control Unit is not connected correctly to the Irrigation Valve.	→ Connect the Control Unit correctly to the Irrigation Valve.
<b>Irrigation valve does not close, continuous water flow</b>	Irrigation valve is installed opposite to the flow direction.	→ Turn the Irrigation valve (observe the flow direction).
	Selection lever ⑨ is set to <b>ON</b> .	→ Set the selection lever ⑨ to <b>AUTO/OFF</b> .



**NOTE: For any other malfunctions please contact the GARDENA service department. Repairs must only be done by GARDENA service departments or specialist dealers approved by GARDENA.**

## 8. TECHNICAL DATA

<i>Irrigation Valve Bluetooth®</i>	Unit	Value (Art. 1285)
------------------------------------	------	-------------------

Voltage	V (DC)	9
---------	--------	---

### **SRD:**

Frequency range	GHz	2,402 – 2,480
-----------------	-----	---------------

Maximum power	mW	10
---------------	----	----

Free field radio range (approx.)	m	5
----------------------------------	---	---

Min./max. operating pressure	bar	0,5 / 12
------------------------------	-----	----------

<b>Irrigation Valve Bluetooth®</b>	<b>Unit</b>	<b>Value (Art. 1285)</b>
<b>Flow medium</b>		Clear fresh water
<b>Max. liquid temperature</b>	°C	40
<b>Battery required</b>		1 x 9 V alkaline manganese Typ IEC 6LR61
<b>Operating time of the battery (approx.)</b>	a	1

## ***EC Declaration of Conformity***

---

Hereby, GARDENA Manufacturing GmbH declares that the radio equipment type (Art. 1285) is in compliance with directive 2014/53/EU.

The full text of the EC declaration of conformity is available at the following internet address:

**<http://www.gardena.com/int/support/safety-regulations>**

## **9. ACCESSORIES**

---

**GARDENA Soil Moisture Sensor**

For irrigation depending on the soil moisture.

**Art. 1867**

## 10. SERVICE/WARRANTY

---

**Service:**

Please contact the address on the back page.

**Warranty statement:**

The manufacturer's warranty can be viewed at:

**[www.gardena.com/warranty](http://www.gardena.com/warranty) or**

**Phone number +49 731 4903773**

This manufacturer's warranty is limited to replacement and repair of products in accordance with the abovementioned conditions. The manufacturer's warranty does not constitute an entitlement to lodge other claims against us as a manufacturer, such as for damages. This manufacturer's warranty does not, of course, affect statutory and contractual warranty claims against the dealer/retailer.

The manufacturer's warranty is governed by the law of the Federal Republic of Germany.

### ***Trademark Attribution Footnote:***

---

The Bluetooth® word mark and logos are registered trademarks owned by Bluetooth SIG, Inc. and any use of such

marks by GARDENA is under license. Other trademarks and trade names are those of their respective owners.

### ***Product liability***

---

In accordance with the German Product Liability Act, we hereby expressly declare that we accept no liability for damage incurred from our products where said products

have not been properly repaired by a GARDENA-approved service partner or where original GARDENA parts or parts authorised by GARDENA were not used.

**Deutschland / Germany**

GARDENA Manufacturing GmbH  
Central Service  
Hans-Lorenser-Straße 40  
D-89079 Ulm  
Produktfragen: (+49) 731 490-123  
Reparaturen: (+49) 731 490-290  
service@gardena.com  
http://www.gardena.com

**Albania**

KRAFT SHPK  
Autostrada Tirane-Durrës  
Km 7  
1051 Tirane

**Argentina**

ROBERTO C. RUMBO S.R.L.  
Predio Norlog  
Lote 7  
Benavidez, ZC: 1621  
Buenos Aires  
ventas@rumbosrl.com.ar

**Australia**

Husqvarna Australia Pty. Ltd.  
Locked Bag 5  
Central Coast BC  
NSW 2252  
Phone: (+61) (0) 2 4352 7400  
customer.service@  
husqvarna.com.au

**Austria / Österreich**

Husqvarna Austria GmbH  
Industriezeile 36  
4010 Linz  
Tel.: (+43) 732 77 01 01-485  
service.gardena@  
husqvarnagroup.com

**Azerbaijan**

Firm Progress  
a. Aliyev Str. 26A  
1052 Baku

**Belarus**

Private Enterprise  
"Master Garden"  
Minsk  
Sharangovich str., 7a  
Phone: (+375) 17 257-00-33  
Mob.: (+375) 29 676-16-09  
mg@mastergarden.by

**Belgium**

Husqvarna Belgium nv  
Gardena Division  
Leuvensesteenweg 542  
Planet II E  
1930 Zaventem  
België

**Bosnia / Herzegovina**

SILK TRADE d.o.o.  
Industrijska zona Bukva bb  
74260 Tešanj

**Brazil**

Husqvarna do Brasil Ltda  
Av. Francisco Matarazzo,  
1400 – 19ª andar  
São Paulo – SP  
CEP: 05001-903  
Tel: 0800-112252  
marketing.br.husqvarna@  
husqvarna.com.br

**Bulgaria**

AGROLAND България АД  
бул. 8 Декември, № 13  
Офис 5  
1700 Студентски град  
София  
Tel.: (+359) 2466 6910  
info@agroland.eu

**Canada / USA**

GARDENA Canada Ltd.  
100 Summerlea Road  
Brampton, Ontario L6T 4X3  
Phone: (+1) 905 792 93 30  
info@gardenacanada.com

**Chile**

REPRESENTACIONES  
JCE S.A.  
Av. Del Valle Norte 857,  
Piso 4  
Santiago RM  
Phone: (+56) 212442560  
contacto@jce.cl

**China**

Husqvarna (Shanghai)  
Management Co., Ltd.  
富世华 (上海) 管理有限公司  
3F, Benq Square B,  
No207, Song Hong Rd.,  
Chang Ning District,  
Shanghai, PRC. 200335  
上海市长宁区淞虹路207号明  
基广场B座3楼, 邮编: 200335

**Colombia**

Husqvarna Colombia S.A.  
Calle 18 No. 68 D-31, zona  
Industrial de Montevideo  
Bogotá, Cundinamarca  
Tel. 571 2922700 ext. 105  
jairo.salazar@husqvarna.com.co

**Costa Rica**

Compania Exim  
Euroiberamericana S.A.  
Los Colegios, Moravia,  
200 metros al Sur del Colegio  
Saint Francis – San José  
Phone: (+506) 297 68 83  
exim\_euro@racsa.co.cr

**Croatia**

Husqvarna Austria GmbH  
Industriezeile 36  
4010 Linz  
Tel.: (+43) 732 77 01 01-485  
service.gardena@  
husqvarnagroup.com

**Cyprus**

Med Marketing  
17 Digeni Akrita Ave  
P.O. Box 27017  
1641 Nicosia

**Czech Republic**

Husqvarna Česko s.r.o.  
Türkova 2319/5b  
149 00 Praha 4 – Chodov  
Bezplatná infolinka :  
800 100 425  
servis@cz.husqvarna.com

**Denmark**

GARDENA DANMARK  
Lejrevej 19, st.  
3500 Værløse  
Tlf.: (+45) 70 26 47 70  
husqvarna@husqvarna.dk  
www.gardena.com / dk

**Dominican Republic**

BOSQUESA, S.R.L  
Carretera Santiago Licey  
Km. 5 ½  
Esquina Copal II.  
Santiago  
Dominican Republic  
Phone: (+809) 736-0333  
joserbosquesa@claro.net.do

**Ecuador**

Husqvarna Ecuador S.A.  
Arupos E1-181 y 10 de  
Agosto Quito, Pichincha  
Tel. (+593) 22800739  
francisco.jacome@  
husqvarna.com.ec

**Estonia**

Husqvarna Eesti OÜ  
Valdeku 132  
EE-11216 Tallinn  
info@gardena.ee

**Finland**

Oy Husqvarna Ab  
Gardena Division  
Lautatarhankatu 8 B / PL 3  
00581 HELSINKI  
www.gardena.fi

**France**

Husqvarna France  
9/11 Allée des pierres mayettes  
92635 Gennevilliers Cedex  
France  
http://www.gardena.com/ fr  
N° AZUR: 0 810 00 78 23  
(Prix d'un appel local)

**Georgia**

Transporter LLC  
113b Beshlavili street  
0159 Tbilisi, Georgia

**Great Britain**

Husqvarna UK Ltd  
Preston Road  
Aycliffe Industrial Park  
Newton Aycliffe  
County Durham  
DL5 6UP  
info.gardena@husqvarna.co.uk

**Greece**

Π.ΠΑΠΑΔΟΠΟΥΛΟΣ ΑΕΒΕ  
Λεωφ. Αθηνών 92  
Αθήνα  
T.K.104 42  
Ελλάδα  
Tel. (+30) 210 5193100  
info@papadopoulos.com.gr

**Hungary**

Husqvarna Magyarországi Kft.  
Ezred u. 1-3  
1044 Budapest  
Telefon: (+36) 1 251-4161  
vevoszolgalat.husqvarna@  
husqvarna.hu

**Iceland**

BYKO ehf.  
Bildshófa 20  
110 Reykjavik

**Ireland**

Husqvarna UK Ltd  
Preston Road  
Aycliffe Industrial Park  
Newton Aycliffe  
County Durham  
DL5 6UP  
info.gardena@husqvarna.co.uk

**Italy**

Husqvarna Italia S.p.A.  
Via Santa Vecchia 15  
23868 VALMADRERA (LC)  
Phone: (+39) 0341.203.111  
assistenza.italia@it.husqvarna.com

**Japan**  
Husqvarna Zenoah Co., Ltd.  
1-9 Minamidai  
Kawagoe  
350-1165 Saitama  
gardena-jp@husqvarnagroup.com

**Kazakhstan**  
LAMED Ltd.  
155/1, Tazhibayevoi Str.  
050060 Almaty  
IP Schmidt  
Abayavenue 3B  
110 005 Kostanay

**Korea**  
Kyung Jin Trading CO.,LTD.  
107-4, SunDuk Bid.,  
YangJae-dong,  
Secho-gu,  
Seoul, (zipcode: 137-891)  
Phone: (+82) (0)2 574-6300

**Latvia**  
Husqvarna Latvija SIA  
Ulbrokas 19A  
LV-1021 Riga  
info@gardena.lv

**Lithuania**  
UAB Husqvarna Lietuva  
Ateities pl. 77C  
LT-52104 Kaunas  
info@gardena.lt

**Luxembourg**  
Magasins Jules Neuberg  
39, rue Jacques Stas  
Luxembourg-Gasperich 2549  
Case Postale No. 12  
Luxembourg 2010  
Phone: (+352) 40 14 01  
api@neuberg.lu

**Mexico**  
AFOSA  
Av. Lopez Mateos Sur # 5019  
Col. La Calma 45070  
Zapopan, Jalisco, Mexico  
Phone: (+52) 33 3818-3434  
icornejo@afosa.com.mx

**Moldova**  
Convel S.R.L.  
290A Muncesti Str.  
2002 Chisinau

**Netherlands**  
Husqvarna Nederland B.V.  
GARDENA Division  
Postbus 50131  
1305 AC ALMERE  
Phone: (+31) 36 521 00 10  
info@gardena.nl

**Neth. Antilles**  
Jonka Enterprises N.V.  
Sta. Rosa Weg 196  
P.O. Box 8200  
Curaçao  
Phone: (+599) 9 767 66 55  
pgm@jonka.com

**New Zealand**  
Husqvarna New Zealand Ltd.  
PO Box 76-437  
Manukau City 2241  
Phone: (+64) (0) 9 9202410  
support.nz@husqvarna.co.nz

**Norway**  
Husqvarna Norge AS  
Gardena Division  
Trøskenveien 36  
1708 Sarpsborg  
info@gardena.no

**Peru**  
Husqvarna Perú S.A.  
Jr. Ramón Cárcamo 710  
Lima 1  
Tel: (+51) 1 3320400 ext. 416  
juan.remuzgo@husqvarna.com

**Poland**  
Husqvarna Poland Spółka z o.o.  
ul. Wysockiego 15 b  
03-371 Warszawa  
Phone: (+48) 22 330 96 00  
gardena@husqvarna.com.pl

**Portugal**  
Husqvarna Portugal, SA  
Lagoa - Albarraque  
2635 - 595 Rio de Mouro  
Tel.: (+351) 21 922 85 30  
Fax : (+351) 21 922 85 36  
info@gardena.pt

**Romania**  
Madex International Srl  
Soseaua Odaiei 117 - 123,  
RO 013603 Bucuresti, S1  
Phone: (+40) 21 352.76.03  
madex@ines.ro

**Russia / Россия**  
000 „Хускварна“  
141400, Московская обл.,  
г. Химки,  
улица Ленинградская,  
владение 39, стр.6  
Бизнес Центр  
„Химки Бизнес Парк“,  
помещение 0B02\_04  
http://www.gardena.ru

**Serbia**  
Domel d.o.o.  
Autoput za Novi Sad bb  
11273 Belgrade  
Phone: (+381) 1 18 48 88 12  
miroslav.jejina@domel.rs

**Singapore**  
Hy-Ray PRIVATE LIMITED  
40 Jalan Pemimpin  
#02-08 Tat Ann Building  
Singapore 577185  
Phone: (+65) 6253 2277  
shiyang@hyray.com.sg

**Slovak Republic**  
Husqvarna Česko s.r.o.  
Türkova 2319/5b  
149 00 Praha 4 – Chodov  
Bezplatná infolinka:  
800 154 044  
servis@sk.husqvarna.com

**Slovenia**  
Husqvarna Austria GmbH  
Industriezeile 36  
4010 Linz  
Tel. : (+43) 732 77 01 01-485  
service.gardena@husqvarnagroup.com

**South Africa**  
Husqvarna  
South Africa (Pty) Ltd  
Postnet Suite 250  
Private Bag X6,  
Cascades, 3202  
South Africa  
Phone: (+27) 33 846 9700  
info@gardena.co.za

**Spain**  
Husqvarna España S.A.  
Calle de Rivas nº 10  
28052 Madrid  
Phone: (+34) 91 708 05 00  
atencioncliente@gardena.es

**Suriname**  
Deto Handelmaatschappij N.V.  
Kernkampweg 72-74  
P.O.Box: 12782  
Paramaribo – Suriname  
South America  
Phone: (+597) 438050  
www.deto.sr

**Sweden**  
Husqvarna AB/GARDENA Sverige  
Drottninggatan 2  
561 82 Huskvarna  
Sverige

**Switzerland / Schweiz**  
Husqvarna Schweiz AG  
Consumer Products  
Industriestrasse 10  
5506 Mägenwil  
Phone: (+ 41) (0) 62 887 37 90  
info@gardena.ch

**Turkey**  
Dost Bahçe Diş Ticaret  
Mümesillik A.Ş  
Yunus Mah. Adil Sok. No: 3  
İc Kapi No: 1 Kartal  
34873 İstanbul  
Phone: (+90) 216 38 93 939  
info@dostbahce.com.tr

**Ukraine / Україна**  
ТОВ «Хускварна Україна»  
вул. Васильківська, 34,  
офіс 204-г  
03022, м. Київ  
Тел. (+38) 0 800 504 804  
info@gardena.ua

**Uruguay**  
FELI SA  
Entre Rios 1083 CP 11800  
Montevideo – Uruguay  
Tel : (+598) 22 03 18 44  
info@felisa.com.uy

**Venezuela**  
Corporación Casa y Jardín C.A.  
Av. Caroní, Edif. Trezmen, PB.  
Colinas de Bello Monte.  
1050 Caracas.  
Tel : (+58) 212 992 33 22  
info@casayjardin.net.ve

1285-20.960.01/0121  
© GARDENA Manufacturing GmbH  
D-89079 Ulm  
http://www.gardena.com