

SimpliGlide 300	Art. 970482562	Art. 970482502
SimpliGlide 330	Art. 970482862	Art. 970482802
SimpliGlide 360	Art. 970482962	Art. 970482902

EN Operator's manual
Electric Hover Lawnmower

A1**A2****A3****O1****O2****O3****O4****O5****O6****O7****O8****M1**

M2

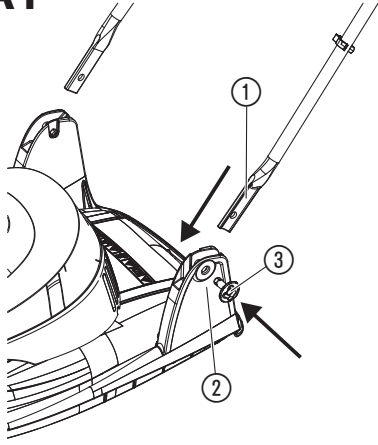
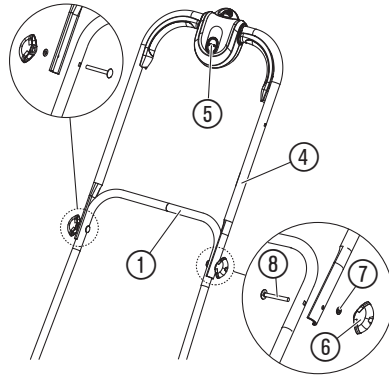
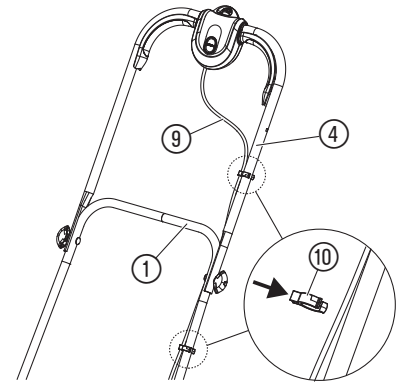
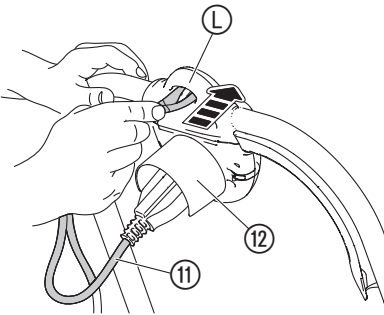
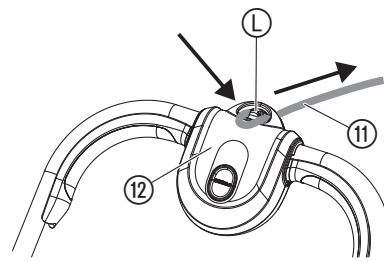
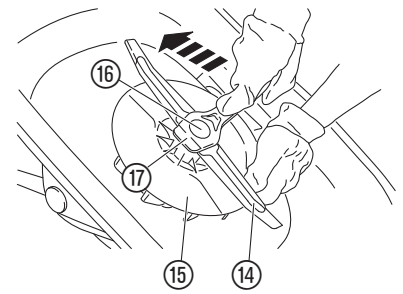
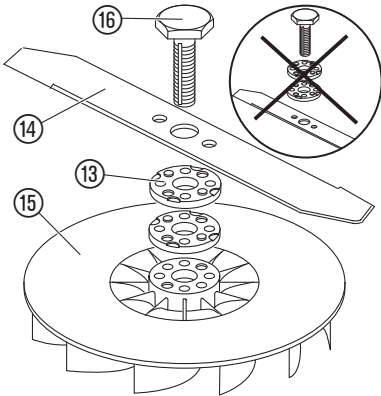
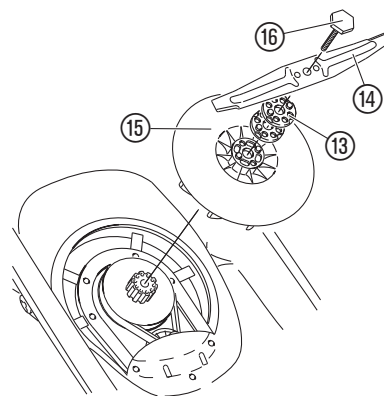
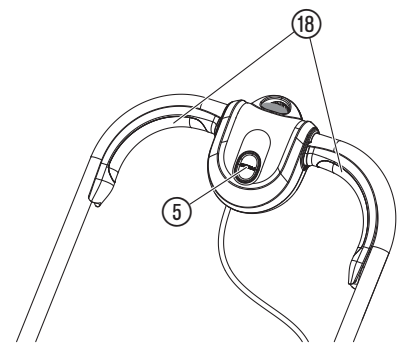
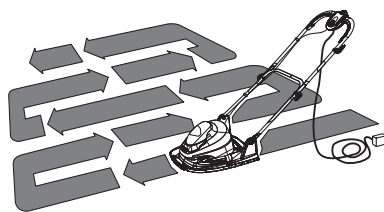
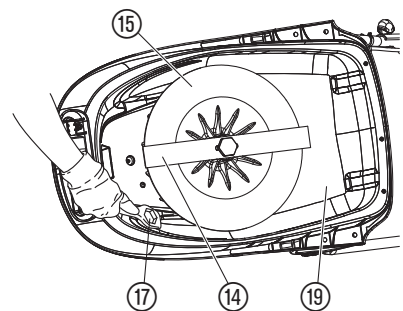
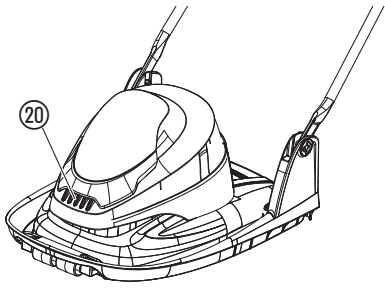

S1

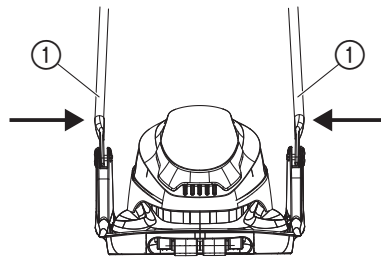

S2

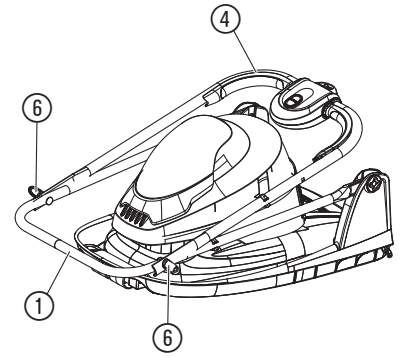

S3

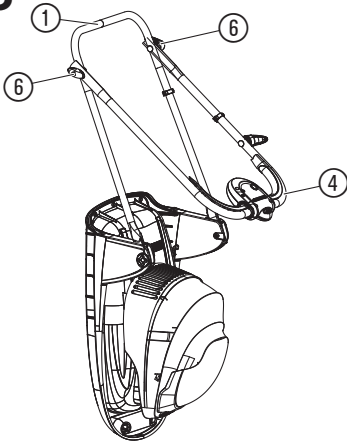

EN Electric Hover Lawnmower

1. SAFETY	4
2. ASSEMBLY	5
3. OPERATION	5
4. MAINTENANCE	6
5. STORAGE	6
6. TROUBLESHOOTING	6
7. TECHNICAL DATA	7
8. ACCESSORIES	7
9. SERVICE/WARRANTY	7

Original instructions.



This product may be used under supervision, or if instruction regarding the safe use of the product has been provided and the resulting dangers have been understood, by children aged 8 and above, as well as by persons with physical, sensory or mental disabilities or a lack of experience and knowledge. Children must not be allowed to play with the product. Cleaning and user maintenance must not be performed by children without supervision. The use of this product by young people under the age of 16 is not recommended.

Intended use:

The **FLYMO Lawnmower** is intended to mow lawn in private domestic gardens and allotments.

The product is not intended for long term use.



DANGER! Risk of injury!

→ Do not use the product to cut bushes, hedges, shrubs, to cut of climbers or grass on roofs or balcony boxes, to chop up branches, twigs and to level irregularities in the soil. Do not use the product on a slope steeper than 20° maximum.

1. SAFETY

IMPORTANT!

Read the operator's manual carefully before use and keep for future reference.

Symbols on the product:



Read operator's manual.



Keep bystanders away.



Beware of sharp blades. Blades continue to rotate after the motor is switched off. Remove plug from mains before maintenance or if cord is damaged.



Keep the mains cable away from the cutting blades.

General safety warnings

Electrical safety



DANGER! Electric shock!

Risk of injury due to electric shock.

→ The product must be supplied through a residual current device (RCD) having a rated residual operating current not exceeding 30 mA.



WARNING! Risk of physical injury!

Cut injury when the blade turns or the product starts accidentally.

→ Disconnect the product from the mains before you do maintenance or you replace parts. Thereby the disconnected socket must be in the visual range.

Cables

If extension cables are used, these must comply with the minimum cross-sections in the table below:

Voltage	Cable length	Cross section
220 – 240 V / 50 Hz	Up to 40 m	1.0 mm ²
220 – 240 V / 50 Hz	Up to 60 m	1.5 mm ²
220 – 240 V / 50 Hz	Up to 100 m	2.5 mm ²

Minimum rating: 1.0 mm² size cable, 10 amps 250 volts AC.

Your product is supplied with cable wired directly into the product.

- If the supply cord is damaged, it must be replaced by your local Husqvarna UK Ltd. Approved Service Centre or similarly qualified persons in order to avoid a hazard.
- Do not wire an extension cable directly to your product yourself. Please contact your local Husqvarna UK Ltd. Approved Service Centre for further information on the connectors and kits available.
- Only use extension cables specifically designed for outdoor use and which conform to one of the following specifications: Ordinary rubber (60245 IEC 53), Ordinary PVC (60227 IEC 53) or Ordinary PCP (60245 IEC 57).

Training

- Read the instructions carefully. Be familiar with the controls and the correct use of the machine.
- Never allow children or people unfamiliar with these instructions to use the machine. Local regulations can restrict the age of the operator.
- Never operate the machine while people, especially children, or pets are nearby.
- Keep in mind that the operator or user is responsible for accidents or hazards occurring to other people or their property.

Preparation

- While operating the machine always wear substantial footwear and long trousers. Do not operate the machine when barefoot or wearing open sandals. Avoid wearing clothing that is loose fitting or that hanging cords or ties.
- Thoroughly inspect the area where the machine is to be used and remove all objects which can be thrown by the machine.
- Before using, always visually inspect to see that the blade, blade bolt and the blade assembly are not worn or damaged. Replace worn or damaged components in set to preserve balance. Replace damaged or unreadable labels.
- Before use check the supply and extension cord for signs of damage or aging. If the cord becomes damaged during use, disconnect the cord from the supply immediately.
DO NOT TOUCH THE CORD BEFORE DISCONNECTING THE SUPPLY.
Do not use the machine if the cord is damaged or worn.

Operation

- Operate the machine only in daylight or in good artificial light.
- Avoid operating the machine in wet grass.
- Always be sure of your footing on slopes.
- Walk, never run.
- Mow across the face of slopes, never up and down.
- Exercise extreme caution when changing direction on slopes.
- Do not mow excessively steep slopes.
- Use extreme caution when reversing or pulling the machine towards you.
- Stop the blade(s) if the machine has to be tilted for transportation when crossing surfaces other than grass, and when transporting the machine to and from area to be used.
- Never operate the machine with defective guards or shields, or without safety devices, for example deflectors and/or grass collector, in place.
- Switch on the motor carefully according to instructions and with feet well away from the blade(s).
- Do not tilt the machine when switching on the motor, except if the machine has to be tilted for starting. In this case, do not tilt it more than absolutely necessary and lift only the part, which is away from the operator.
- Do not start the machine when standing in front of the discharge opening.
- Do not put hands or feet near or under rotating parts. Keep clear of the discharge opening at all times.
- Do not transport the machine while the power source is running.
- Stop the machine, and remove plug from the socket. Make sure that all moving parts have come to a complete stop.
 - whenever you leave the machine,
 - before clearing blockages or unclogging chute,
 - before checking, cleaning or working on the machine,
 - after striking a foreign object. Inspect the machine for damage and make repairs before restarting and operating the machine;

if the machine starts to vibrate abnormally (check immediately)

- inspect for damage,
- replace or repair any damaged parts,
- check for and tighten any loose parts.

Maintenance and storage

- Keep all nuts, bolts, and screws tight to be sure the machine is in safe working condition.
- Check the grass collector frequently for wear or deterioration.
- Replace worn or damaged parts for safety.
- On machines with multi blade, take care as rotating one blade can cause other blades rotate.
- Be careful during adjustment of the machine to prevent entrapment of the fingers between moving blades and fixed parts of the machine.
- Always allow the machine to cool down before storing.
- When servicing the blades be aware that, even though the power source is switched off, the blades can still be moved.
- Use only genuine replacement parts and accessories.

Additional safety warnings

Electrical safety



DANGER! Cardiac arrest!

This product makes an electromagnetic field while it operates. This field may under some conditions interfere with active or passive medical implants. To decrease the risk of conditions that can possibly injure or kill, we recommend persons with medical implants to speak with their physician and the medical implant manufacturer before you operate the product.

Before use, examine the cable for signs of damage or ageing. If the cable is found to be defective, take the product to an authorised Service Centre and have the cable replaced.

Do not use the product if the electric cables are damaged or worn.

Immediately disconnect from the mains if the cable is cut, or the insulation is damaged. Do not touch the electric cable until the cable has been disconnected. Do not repair a cut or damaged cable. Replace it with a new one.

The extension cable must be uncoiled. Coiled cables can overheat and reduce the efficiency of your mower.

Keep the extension cable away from product, always work away from the power point mowing up and down, never in circles.

Do not pull cable around sharp objects.

Always switch off at the mains before disconnecting any plug, cable connector or extension cable.

Stop the motor, disconnect the mains and examine the cable for damage or ageing before you wind the cable for storage. Do not repair a damaged cable, replace it with a new one. Use only genuine replacement cable.

Always wind the cable carefully, avoid kinking.

Do not carry the product by the cable.

Do not pull on the cable to disconnect any of the plugs.

Use only on AC mains supply voltage shown on the product rating label.

Our products are double insulated to EN60335. Do not connect an earth to any part of the product.

Check the working area for hidden cables.

Do not use for pond care or close to water.

Personal safety



DANGER! Risk of suffocation!

Small parts can be easily swallowed. There is also a risk that the poly-bag can suffocate toddlers. Keep toddlers away when you assemble the product.

Let the hover mower to cool down for at least 30 minutes before storage or maintenance.

If blockage of cutting element stop product and check.

Do not tilt the machine into the direction of the user.

Do not move backwards.

Stay alert during operation.

Do not use in explosive atmosphere.

Do not operate the product when you are tired, ill or under the influence of alcohol, drugs or medicine or when you are exhausted.

Do not overload the mower.

Use gloves, wear slip resistant shoes and wear eye protection.

Do not use under wet conditions.

Do not use on wet grass.

Do not disassemble the product further than the delivery status.

Only start the mower with an upright standing handle.

Do not use the start levers alternately.

Use the handles carefully.

Safety Cut-Out

The motor is protected by a Safety Cut-Out which is activated when the blade becomes jammed or if the motor is overloaded. When this occurs, stop and disconnect the product from the mains. The Safety Cut-Out will only reset when you release the start/stop lever. Clear any obstruction and wait for a few minutes for the Safety Cut-Out to reset before you continue to use the product.

2. ASSEMBLY



DANGER! Risk of injury!

Cut injury when the product starts accidentally.

→ Wait for the blade to stop, disconnect the product from the mains and use gloves before you assemble the product.

To assemble the lower handle [Fig. A1]:

- Place the end of the lower handle ① into the slots on the deck ②.
- Secure the lower handles ① to the deck ② by firmly pushing fixing pin ③ through the holes in the deck ② and handle ①.
- Repeat on the other side.

NOTE: Should a problem occur when securing the handle to the deck with the fixing pin, carefully lever fixing pin out of location and repeat steps 1 to 3 above.

To assemble the upper handle [Fig. A2/A3]:

- Make sure that the upper handle ④ is located correctly with the safety lock-off button ⑤ on the switchbox facing upwards.
- Make sure that the upper handle ④ and the lower handle ① are aligned correctly.
- Insert the nut into the handle knob ⑥ (if necessary).
- Fit the bolts ⑥, the washers ⑦ and the handle knobs ⑥ onto the handles ①/④ in the correct positions.
- Attach the cable ⑨ to the handles ①/④ with the clips ⑩ provided. Make sure that the cable ⑨ is not trapped between the upper handle ④ and lower handle ①.

3. OPERATION



DANGER! Risk of injury!

Cut injury when the product starts accidentally.

→ Wait for the blade to stop, disconnect the product from the mains and use gloves before you adjust or transport the product.

To connect the mower [Fig. O1/O2]:



DANGER! Electric shock!

To avoid damage to the extension cable ⑪, the extension cable ⑪ must be inserted into the cable lock ⑬.

→ Before you operate insert the extension cable ⑪ into the cable lock ⑬.

- Connect the female extension cable ⑪ connector to the back of the switchbox ⑫.
- Form a loop in the extension cable ⑪, insert the loop into the cable lock ⑬ slot in the switchbox ⑫ and pull tight.
- Connect the extension cable ⑪ into a 230 V mains socket.

To adjust the cutting height [Fig. O3/O4/O5]:



CAUTION! Do not use more than 3 cutting height spacers ⑬. The cutting height spacers ⑬ must only be fitted between the blade ⑭ and the fan ⑮. Do not fit the cutting height spacers ⑬ between the blade ⑭ and the blade bolt ⑯.

- To remove the blade bolt ⑯, hold the fan ⑮ firmly and loosen the blade bolt ⑯ with the spanner ⑰ provided.
- Remove the blade bolt ⑯, the blade ⑭, the cutting height spacers ⑬ and the fan ⑮.
- Inspect for damage and clean as necessary.
- Put the fan ⑮ on the product.
Make sure that the fan ⑮ is fully in place and the hole of the fan is inline up with the threaded hole.
- Put the cutting height spacers ⑬ onto the fan ⑮.
Higher Cut – less cutting height spacers
Lower Cut – more cutting height spacers
Make sure that the pegs have located into the holes.
- Put the blade ⑭ on by aligning the D-shaped holes onto the cutting height spacers ⑬.
Make sure that the pegs have located into the holes on the blade.

- Put the blade bolt (16) through the centre hole of the blade (14).
- Tighten down the blade bolt (16) clockwise by hand.
- Hold the fan (15) firmly and tighten the blade bolt (16) with the spanner (17) provided.

Operation position:

Adjustment is not required to move the handle to the operating position. Simply pull down from the forward position or lift up from the down position until the handle is in the most comfortable operating position.

To start the mower [Fig. O6/O7]:



DANGER! Risk of injury!

Risk of injury if the product does not stop when you release the start levers.

→ Do not bypass the safety devices or switches. For example do not attach the start levers to the handle.

To start:

The product is provided with a two-handed safety device (start lever (18) and safety lock-off button (5)) to prevent the product from being turned on by accident.

There are two start levers (18) fitted. Either one has to be used to start.

- Push the safety lock-off button (5) with one hand and pull the start lever (18) with the other hand.
The mower starts.

- Release the safety lock-off button (5).

To prevent a ring being cut in the lawn and to clear any residual grass, tilt the mower slightly. When the lawnmower has reached full speed gently lower it onto the lawn.

To stop:

→ Release the start lever (18).
The mower stops.

Tips to use the mower [Fig. O8]:

Mow twice a week during the growing season.

The lawn will suffer if more than a third of its length is cut at one time.

For the best results mow the outside edge of the lawn in a clockwise direction first.

Start to mow the edge of the lawn nearest to the power point.
So the cable is laid out on the lawn you have already cut.

For the best cutting results mow in straight lines with an overlap of approximately 8 – 10 cm on each pass with the mower.

Do not overload the mower. To mow long thick grass may cause the motor speed to drop and you will hear a change in the motor sound. If the motor speed drops you may overload the mower which may cause damage. When you mow in long thick grass a first cut with the cutting height set higher will help reduce the load.

See *To adjust the cutting height*.

4. MAINTENANCE



DANGER! Risk of injury!

Cut injury when the product starts accidentally.

→ Wait for the blade to stop, disconnect the product from the mains and use gloves before you maintain the product.

To clean the mower:



DANGER! Risk of injury!

Risk of injury and risk of damage to the product.

→ Do not clean the product with water or with a water jet (in particular high-pressure water jet).

→ Do not clean with chemicals including petrol or solvents. Some can destroy critical plastic parts.

The airflow slots must always be clean.

To clean the underside of the mower [Fig. M1]:

The underside is easiest to clean after you mowed.

- Lay the mower on its side carefully.
- Clean the underside (19) by removing any grass build up with the spanner/scrapper tool (17).
- Clean the blade (14) and the fan (15) with a soft brush (do not use sharp objects).

To clean the outside of the mower [Fig. M2]:

- Clean the outside with a dry cloth.
- Clean the airflow slots (20) with a soft brush (do not use sharp objects).

5. STORAGE

To put into storage:

The product must be stored away from children.

- Disconnect the product from the mains.
- Clean the mower (see 4. MAINTENANCE).
- Store the mower in a dry, enclosed and frost-free place.

Storage positions [Fig. S1]:

- Push the lower handle (1) inwards from both sides simultaneously.
- Rotate the handle (1) to the desired position, either forward for the folding storage position or backward for the wall mounting storage position.
- Loosen the handle knobs (6) and fold the upper handle (4).
Make sure that the cable is not locked between the lower and the upper handle.

Folding storage position [Fig. S2]

Wall mounting storage position [Fig. S3]

NOTE: When wall-mounting storage, always hang the mower from the lower handle (1) cross section.

Disposal:

(in accordance with RL2012/19/EC)



The product must not be disposed of to normal household waste. It must be disposed of in line with local environmental regulations.

IMPORTANT!

→ Dispose of the product through or via your municipal recycling collection centre.

6. TROUBLESHOOTING



DANGER! Risk of injury!

Cut injury when the product starts accidentally.

→ Wait for the blade to stop, disconnect the product from the mains and use gloves before you troubleshoot the product.

To replace the blade:



DANGER! Risk of injury!

Cut injury when the blade turns and it is damaged, bent, out of balance or has chipped edges.

→ Do not use the mower when the blade is damaged, bent, out of balance or has chipped edges.

→ Do not grind the blade.

The FLYMO spare parts are available from your FLYMO dealer or from the FLYMO service.

Only use an original FLYMO blade:

FLYMO Replacement Blade for 30 cm:

Reference no. FLY094

Part no. 529370590

FLYMO Replacement Blade for 33 cm:

Reference no. FLY095

Part no. 529370790

FLYMO Replacement Blade for 36 cm:

Reference no. FLY096

Part no. 529370890

→ Replace the blade (see 3. OPERATION *To adjust the cutting height*).

Problem	Possible Cause	Remedy
Mower does not start	Mains cable is disconnected or damaged.	→ Connect the mains cable or if necessary replace it.
	Motor is blocked.	→ Remove the obstacle.
Motor is jammed and makes a noise	Motor is blocked.	→ Remove the obstacle.
	Cutting height is too low.	→ Raise the cutting height.
Loud noises, the mower is rattling	Screws on motor, its fixing or on the mower chasing are loose.	→ Let the screws be tightened by an authorised specialist dealer.

Problem	Possible Cause	Remedy
Mower runs unevenly or vibrates strongly	Blade is damaged/ worn or the blade mounting is released.	→ Replace the blade.
	Blade is very dirty.	→ Clean the mower (see 4. MAINTENANCE). If this does not rectify the problem, replace the blade.
Lawn is not cleanly mowed	Blade is blunt or damaged.	→ Replace the blade.
	Cutting height is too low.	→ Raise the cutting height.
Poor flotation	Underside of the mower is dirty.	→ Clean the underside of the mower.
	Cutting height is too low.	→ Raise the cutting height.
	Fan is damaged.	→ Check and replace the fan.
	If poor flotation persists, contact the local approved Service Centre.	



NOTE: For any other malfunctions please contact the FLYMO service department. Repairs must only be done by FLYMO service departments or specialist dealers approved by FLYMO.

7. TECHNICAL DATA

Electric Hover Lawnmower	Unit	Value (30 cm)	Value (33 cm)	Value (36 cm)
Rated power	W	1700	1700	1800
Mains voltage	V	230	230	230
Mains frequency	Hz	50	50	50
Speed of rotation cutting blade	R/min	4200	4200	4200
Cutting width	cm	30	33	36
Cutting height adjustment (4 positions)	mm	10 – 30	10 – 30	10 – 30
Weight	kg	6.7	6.7	6.9
Sound pressure level L_{pA}¹⁾	dB (A)	84	83	80
Uncertainty k_{pA}		3	3	3
Sound power level L_{WA}²⁾: measured/guaranteed	dB (A)	92 / 96	92 / 96	92 / 96
Uncertainty k_{WA}		3.9	3.2	3.2
Hand/arm vibration a_{vhw}¹⁾	m/s ²	1.5	1.5	1.9
Uncertainty k_{vhw}		1.5	1.5	1.5

Measuring process complying with: ¹⁾ EN 60335-2-77 ²⁾ RL 2000/14/EC



NOTE: The stated vibration emission value has been measured according to a standardised test procedure and can be used for comparison of one electric power tool with another. It can also be used for preliminary evaluation of exposure. The vibration emission value can vary during actual use of the electric power tool.

Please consult the supply authority, if necessary, that the equipment is connected only to a supply of an impedance no more than 0.354 Ω. This maximum permissible system impedance at the interface point of the user's supply is according to the test value of **SimpliGlide 360V**.

8. ACCESSORIES

FLYMO Replacement Blade for 30 cm	As replacement for blunt blade.	Reference no. FLY094 Part no. 529370590
FLYMO Replacement Blade for 33 cm	As replacement for blunt blade.	Reference no. FLY095 Part no. 529370790
FLYMO Replacement Blade for 36 cm	As replacement for blunt blade.	Reference no. FLY096 Part no. 529370890

9. SERVICE/WARRANTY

Service:

Please contact the address on the back page.

Warranty statement:

In the event of a warranty claim, no charge is levied to you for the services provided.

FLYMO grants a warranty for all original FLYMO new products for two years from the date of original purchase from the retailer, provided that the devices have been for private use only. This manufacturer's warranty does not apply to products acquired second hand. This warranty includes

all significant defects of the product that can be proved to be material or manufacturing faults. This warranty is fulfilled by supplying a fully functional replacement product or by repairing the faulty product sent to us free of charge; we reserve the right to choose between these options. This service is subject to the following provisions:

- The product has been used for its intended purpose as per the recommendations in the operating instructions.
- Neither the purchaser nor a third party has attempted to open or repair the product.
- Only Original FLYMO replacement parts and wear parts have been used for operation.
- Presentation of the receipt.

Normal wear and tear of parts and components (such as blades, blade fixing parts, turbines, light bulbs, V-belts/toothed belts, impellers, air filters, spark plugs), visual changes, wear parts and consumables are excluded from the warranty.

This manufacturer's warranty is limited to replacement and repair of products in accordance with the abovementioned conditions. The manufacturer's warranty does not constitute an entitlement to lodge other claims against us as a manufacturer, such as for damages. This manufacturer's warranty does **not**, of course, affect statutory and contractual warranty claims against the dealer/retailer.

The manufacturer's warranty is governed by the law of the Federal Republic of Germany.

In case of a warranty claim, please return the faulty product, together with a copy of the receipt and a description of the fault, with postage paid to the service address.

Consumables:

The blade is a consumable and is not included in the warranty.

<p>DE Produkthaftung Wir weisen ausdrücklich darauf hin, dass wir in Übereinstimmung mit dem Produkthaftungsgesetz nicht für Schäden haften, die durch unsere Produkte entstehen, wenn diese unsachgemäß und nicht durch einen von uns autorisierten Servicepartner repariert wurden oder wenn keine Original FLYMO Teile oder von uns zugelassene Teile verwendet wurden.</p>
<p>EN Product liability In accordance with the German Product Liability Act, we hereby expressly declare that we accept no liability for damage incurred from our products where said products have not been properly repaired by a FLYMO-approved service partner or where original FLYMO parts or parts authorised by FLYMO were not used.</p>
<p>FR Responsabilité Conformément à la loi relative à la responsabilité du fait des produits défectueux, nous déclarons expressément par la présente que nous déclinons toute responsabilité pour les dommages résultant de nos produits, si lesdits produits n'ont pas été correctement réparés par un partenaire d'entretien agréé FLYMO ou si des pièces d'origine FLYMO ou des pièces agréées FLYMO n'ont pas été utilisées.</p>
<p>NL Productaansprakelijkheid Conform de Duitse wet inzake productaansprakelijkheid verklaren wij hierbij uitdrukkelijk dat wij geen aansprakelijkheid aanvaarden voor schade ontstaan uit onze producten waarbij deze producten niet zijn gerepareerd door een FLYMO-erkende servicepartner of waarbij geen originele FLYMO-onderdelen of onderdelen die door FLYMO zijn goedgekeurd zijn gebruikt.</p>
<p>SV Produktansvar I enlighet med tyska produktansvarslagar förklarar vi härmed uttryckligen att vi inte åtar oss något ansvar för skador som orsakas av våra produkter där produkterna inte har genomgått korrekt reparation från en FLYMO-godkänd servicepartner eller där originaldelar från FLYMO eller delar godkända av FLYMO inte använts.</p>
<p>DA Produkansvar I overensstemmelse med den tyske produktansvarslav erklærer vi hermed udtrykkeligt, at vi ikke påtager os noget ansvar for skader på vores produkter, hvis de pågældende produkter ikke er blevet repareret korrekt af en FLYMO-godkendt servicepartner, eller hvor der ikke er brugt originale FLYMO-reservedele eller godkendte reservedele fra FLYMO.</p>
<p>FI Tuotevastuu Saksan tuotevastuulain mukaisesti emme ole vastuussa laitteiden vaurioista, jos korjauksia ei ole tehnyt FLYMO:n hyväksymä huoltoliike tai jos niiden synnä on muiden kuin alkuperäisten FLYMO-varaosien tai FLYMO:n hyväksymien varaosien käyttö.</p>
<p>IT Responsabilità del prodotto In conformità con la Legge tedesca sulla responsabilità del prodotto, con la presente dichiariamo espressamente che decliniamo qualsiasi responsabilità per danni causati dai nostri prodotti qualora non siano stati correttamente riparati presso un partner di assistenza approvato FLYMO o laddove non siano stati utilizzati ricambi originali o autorizzati FLYMO.</p>
<p>ES Responsabilidad sobre el producto De acuerdo con la Ley de responsabilidad sobre productos alemana, por la presente declaramos expresamente que no aceptamos ningún tipo de responsabilidad por los daños ocasionados por nuestros productos si dichos productos no han sido reparados por un socio de mantenimiento aprobado por FLYMO o si no se han utilizado piezas originales FLYMO o piezas autorizadas por FLYMO.</p>
<p>PT Responsabilidade pelo produto De acordo com a lei alemã de responsabilidade pelo produto, declaramos que não nos responsabilizamos por danos causados pelos nossos produtos, caso os tais produtos não tenham sido devidamente reparados por um parceiro de assistência FLYMO aprovado ou se não tiverem sido utilizadas peças FLYMO originais ou peças autorizadas pela FLYMO.</p>
<p>PL Odpowiedzialność za produkt Zgodnie z niemiecką ustawą o odpowiedzialności za produkt, niniejszym wyraźnie oświadczamy, że nie ponosimy żadnej odpowiedzialności za szkody poniesione na skutek użytkowania naszych produktów, w przypadku gdy naprawa tych produktów nie była odpowiednio przeprowadzana przez zatwierdzonego przez firmę FLYMO partnera serwisowego lub nie stosowano oryginalnych części FLYMO albo części autoryzowanych przez tę firmę.</p>
<p>HU Termékszavatosság A németországi termékszavatossági törvénnyel összhangban ezennel nyomatékosan kijelentjük, hogy nem vállalunk felelősséget a termékeinkben keletkezett olyan károkért, amelyek valamely FLYMO által jóváhagyott szervizpartner által nem megfelelően végzett javításból adódtak, vagy amely során nem eredeti FLYMO alkatrészeket vagy a FLYMO által jóváhagyott alkatrészeket használtak fel.</p>
<p>CS Odpovědnost za výrobek V souladu s německým zákonem o odpovědnosti za výrobek tímto výslovně prohlašujeme, že nepřijímáme žádnou odpovědnost za poškození vzniklá na našich výrobcích, kdy zmíněné výrobky nebyly řádně opraveny schváleným servisním partnerem FLYMO nebo kdy nebyly použity originální náhradní díly FLYMO nebo náhradní díly autorizované společností FLYMO.</p>
<p>SK Zodpovednosť za produkt V súlade s nemeckými právnymi predpismi upravujúcimi zodpovednosť za výrobok týmto výslovné prehlasujeme, že nenesieme žiadnu zodpovednosť za škody spôsobené našimi výrobkami, v prípade ktorých neboli nutné opravy vykonané servisným partnerom schváleným spoločnosťou FLYMO alebo neboli použité diely spoločnosti FLYMO alebo diely schválené spoločnosťou FLYMO.</p>
<p>EL Ευθύνη προϊόντος Σύμφωνα με τον γερμανικό νόμο περί Ευθύνης για τα Προϊόντα, με το παρόν δηλώνουμε ρητώς ότι δεν αποδεχόμαστε καμία ευθύνη για τυχόν ζημιές που προκύπτουν από τα προϊόντα μας εάν αυτά δεν έχουν επισκευαστεί σωστά από κάποιον εγκεκριμένο συνεργάτη επισκευών της FLYMO ή εάν δεν έχουν χρησιμοποιηθεί αυθεντικά εξαρτήματα FLYMO ή εξαρτήματα εγκεκριμένα από την FLYMO.</p>
<p>SL Odgovornost proizvajalca V skladu z nemškimi zakoni o odgovornosti za izdelke, izrecno izjavljajo, da ne sprejemamo nobene odgovornosti za škodo, ki jo povzročijo naši izdelki, če teh niso ustrezno popravili FLYMONINI odobreni servisni partnerji ali pri tem niso bili uporabljeni originalni FLYMONINI nadomestni deli ali FLYMONINIMI homologiranimi nadomestnimi deli.</p>
<p>HR Pouzdanost proizvoda Sukladno njemačkom zakonu o pouzdanosti proizvoda, ovime izričito izjavljujemo kako ne prihvaćamo nikakvu odgovornost za oštećenja na našim proizvodima nastala uslijed neispravnog popravka od strane servisnog partnera kojeg odobrava FLYMO ili uslijed nekorištenja originalnih FLYMO dijelova ili dijelova koje odobrava FLYMO.</p>
<p>RO Răspunderea pentru produs În conformitate cu Legea germană privind răspunderea pentru produs, declarăm în mod expres prin prezentul document că nu acceptăm nicio răspundere pentru defecțiunile suferite de produsele noastre atunci când acestea nu au fost reparate în mod corect de un atelier de service partener, aprobat de FLYMO, sau când nu au fost utilizate piese FLYMO originale sau piese autorizate de FLYMO.</p>
<p>BG Отговорност за вреди, причинени от стоки Съгласно германския Закон за отговорността за вреди, причинени от стоки, с настоящото изрично декларираме, че не носим отговорност за щети, причинени от нашите продукти, ако те не са били правилно ремонтирани от одобрен от FLYMO сервиз или ако не са използвани оригинални части на FLYMO или части, одобрени от FLYMO.</p>
<p>ET Tootevastutus Vastavalt Saksamaa tootevastustusseadusele deklareerime käesolevaga selgesõnaliselt, et me ei kanna mingisugust vastutust meie toodetest tingitud kahjude eest, kui need tooted ei ole korrektselt parandatud FLYMO heakskiidetud hoolduspartneri poolt või kui parandamisel ei ole kasutatud FLYMO originaalosi või FLYMO volitatud osi.</p>
<p>LT Gaminio patikimumas Mes aiškiai pareiškiame, kad, atsižvelgiant į Vokietijos gaminių patikimumo įstatymą, neprisiimame atsakomybės dėl bet kokios žalos, patirtos dėl mūsų gaminių, jeigu jie buvo netinkamai taisomi arba jų dalys buvo pakeistos neoriginaliomis FLYMO dalimis ar nepatvirtintomis dalimis, arba jeigu remonto darbai buvo atliekami ne FLYMO techninės priežiūros centru specialistų.</p>
<p>LV Atbildība par produkcijas kvalitāti Saskaņā ar Vācijas likumu par atbildību par produkcijas kvalitāti ar šo mēs paziņojam, ka neuzņemamies atbildību par bojājumiem, kas radušies, lietojot mūsu izstrādājumu, kuru remontu nav veicis uzņēmuma FLYMO apstiprināts apkopes partneris vai kuru remontam netika izmantotas oriģinālās FLYMO detaļas vai detaļas, kuru lietošanu apstiprinājis uzņēmums FLYMO.</p>

Deutschland / Germany
GARDENA Manufacturing GmbH
Central Service
Hans-Lorenser-Straße 40
D-89079 Ulm
Produktfragen:
(+49) 731 490-123
Reparaturen:
(+49) 731 490-290
service-flymo@gardena.com

Albania
COBALT Sh.p.k.
Rr. Siri Kodra
1000 Tirana

Argentina
Husqvarna Argentina S.A.
Av.del Libertador 5954 –
Piso 11 – Torre B
(C1428ARP) Buenos Aires
Phone: (+54) 11 5194 5000
info.gardena@ar.husqvarna.com

Armenia
Garden Land Ltd.
61 Tigran Mets
0005 Yerevan

Australia
Husqvarna Australia Pty. Ltd.
Locked Bag 5
Central Coast BC
NSW 2252
Phone: (+ 61) (0) 2 4352 7400
customer.service@
husqvarna.com.au

Austria / Österreich
Husqvarna Austria GmbH
Industriezeile 36
4010 Linz
Tel. : (+43) 732 77 01 01-485
service.gardena@
husqvarnagroup.com

Azerbaijan
Firm Progress
a. Aliyev Str. 26A
1052 Baku

Belgium
Husqvarna België nv/sa
Gardena Division
Rue Egide Van Ophem 111
1180 Uccle/Ukkel
Tel.: (+32) 2 720 92 12
Mail: info@gardena.be

Bosnia / Hercegovina
SILK TRADE d.o.o.
Industrijska zona Bukva bb
74260 Tešanj

Brazil
Husqvarna do Brasil Ltda
Av. Francisco Matarazzo,
1400 – 19ª andar
São Paulo – SP
CEP: 05001-903
Tel: 0800-112252
marketing.br.husqvarna@
husqvarna.com.br

Bulgaria
AGROLAND България АД
бул. 8 Декември, № 13
Офис 5
1700 Студентски град
София
Тел.: (+359) 24666910
info@agroland.eu

Canada / USA
GARDENA Canada Ltd.
100 Summerlea Road
Brampton, Ontario L6T 4X3
Phone: (+1) 905 792 93 30
info@gardenacanada.com

Chile
Maquinarias Agroforestales
Ltda. (Maga Ltda.)
Santiago, Chile
Avda. Chesterton
8355 comuna Las Condes
Phone: (+56) 2 202 4417
Dalton@maga.cl
Zipcode: 7560330

China
Husqvarna (China) Machinery
Manufacturing Co., Ltd.
No. 1355, Jia Xin Rd.,
Ma Lu Zhen, Jia Ding Dist.,
Shanghai
201801
Phone: (+86) 21 59159629
Domestic Sales
www.gardena.com.cn

Colombia
Husqvarna Colombia S.A.
Calle 18 No. 68 D-31, zona
Industrial de Montevideo
Bogotá, Cundinamarca
Tel. 571 2922700 ext. 105
jairo.salazar@husqvarna.com.co

Costa Rica
Compania Exim
Euroberoamericana S.A.
Los Colegios, Moravia,
200 metros al Sur del Colegio
Saint Francis – San José
Phone: (+506) 297 68 83
exim_euro@racsa.co.cr

Croatia
SILK ADRIA d.o.o.
Josipa Lončara 3
10090 Zagreb
Phone: (+385) 1 3794 580
silk.adria@zg.t-com.hr

Cyprus
Med Marketing
17 Digeni Akrita Ave
P.O. Box 27017
1641 Nicosia

Czech Republic
Husqvarna Česko s.r.o.
Türkova 2319/5b
149 00 Praha 4 – Chodov
Bezplatná infolinka :
800 100 425
servis@cz.husqvarna.com

Denmark
GARDENA DANMARK
Lejrvej 19, st.
3500 Værløse
Tlf.: (+45) 70 26 47 70
husqvarna@husqvarna.dk
www.gardena.com / dk

Dominican Republic
BOSQUESA, S.R.L
Carretera Santiago Licey
Km. 5 ½
Esquina Copal II.
Santiago
Dominican Republic
Phone: (+809) 736-0333
joserbosquesa@claro.net.do

Ecuador
Husqvarna Ecuador S.A.
Arupos E1-181 y 10 de
Agosto Quito, Pichincha
Tel. (+593) 22800739
francisco.jacome@
husqvarna.com.ec

Estonia
Husqvarna Eesti OÜ
Gardena Division
Valdeku 132
Tallinn
11216, Estonia
info@gardena.ee

Finland
Oy Husqvarna Ab
Gardena Division
Lautatarhankatu 8 B /PL 3
00581 HELSINKI
info@gardena.fi

France
Husqvarna France
9/11 Allée des pierres mayettes
92635 Gennevilliers Cedex
France
http : //www.gardena.com/ fr
N° AZUR: 0 810 00 78 23
(Prix d'un appel local)

Georgia
ALD Group
Beliasvili 8
1159 Tleilisi

Great Britain
Husqvarna UK Ltd
Preston Road
Aycliffe Industrial Park
Newton Aycliffe
County Durham
DL5 6UP
Phone:+44 (0) 344 8444558
customer.services@
husqvarna.co.uk

Greece
Π.ΠΑΠΑΔΟΠΟΥΛΟΣ ΑΕΒΕ
Λεωφ. Αθηνών 92
Αθήνα
T.K.104 42
Ελλάδα
Τηλ. (+30) 210 5193 100
info@papadopoulos.com.gr

Hungary
Husqvarna Magyarorszag Kft.
Ezred u. 1 - 3
1044 Budapest
Telefon: (+36) 1 251-4161
vevoszolgalat.husqvarna@
husqvarna.hu

Iceland
Ó. Johnson & Kaaber
Tunguhalsi 1
110 Reykjavik
ooj@ojk.is

Ireland
Husqvarna UK Ltd
Preston Road
Aycliffe Industrial Park
Newton Aycliffe
County Durham
DL5 6UP
info.gardena@husqvarna.co.uk

Italy
Husqvarna Italia S.p.A.
Via Santa Vecchia 15
23868 VALMADRERA (LC)
Phone: (+39) 0341.203.111
assistenza.italia@
it.husqvarna.com

Japan
KAKUICHI Co. Ltd.
Sumitomo Realty &
Development Kojimachi
BLDG., 8F
5 - 1 Nibanncho
Chiyoda-ku
Tokyo 102-0084
Phone: (+81) 33 264 4721
m_isihara@kaku-ichi.co.jp

Kazakhstan
LAMED Ltd.
155/1, Tazhibayevoi Str.
050060 Almaty
IP Schmidt
Abayavenue 3B
110 005 Kostanay

Korea
Kyung Jin Trading CO.,LTD.
107-4, SunDuk Bld.,
YangJae-dong,
Seocho-gu,
Seoul, (zipcode: 137-891)
Phone: (+82) (0)2 574-6300

Kyrgyzstan
Alye Maki
av. Molodaya Guardir J 3
720014
Bishkek

Latvia
Husqvarna Latvija SIA
Gardena Division
Ulbrokas 19A
LV-1021 Riga
info@gardena.lv

Lithuania
UAB Husqvarna Lietuva
Gardena Division
Ateities pl. 77C
LT-52104 Kaunas
info@gardena.lt

Luxembourg
Magasins Jules Neuberg
39, rue Jacques Stas
Luxembourg-Gasperich 2549
Case Postale No. 12
Luxembourg 2010
Phone: (+352) 40 14 01
api@neuberg.lu

Mexico
AFOSA
Av. Lopez Mateos Sur # 5019
Col. La Calma 45070
Zapopan, Jalisco, Mexico
Phone: (+52) 33 3818-3434
icornejo@afosa.com.mx

Moldova
Convel S.R.L.
290A Muncesti Str.
2002 Chisinau

Netherlands
Husqvarna Nederland B.V.
GARDENA Division
Postbus 50131
1305 AC ALMERE
Phone: (+31) 36 521 00 10
info@gardena.nl

Neth. Antilles
Jonka Enterprises N.V.
Sta. Rosa Weg 196
P.O. Box 8200
Curaçao
Phone: (+599) 9 767 66 55
pgm@jonka.com

New Zealand
Husqvarna New Zealand Ltd.
PO Box 76-437
Manukau City 2241
Phone: (+64) (0) 9 9202410
support.nz@husqvarna.co.nz

Norway
Husqvarna Norge AS
Gardena Division
Trøskeneveien 36
1708 Sarpsborg
Tel: 69 10 47 00
www.gardena.no

Peru
Husqvarna Perú S.A.
Jr. Ramón Cárcamo 710
Lima 1
Tel: (+51) 1 3320400 ext. 416
juan.remuzgo@husqvarna.com

Poland
Husqvarna
Poland Spółka z o.o.
ul. Wysockiego 15 b
03-371 Warszawa
Phone: (+48) 22 330 96 00
gardena@husqvarna.com.pl

Portugal
Husqvarna Portugal, SA
Lagoa - Albarraque
2635 - 595 Rio de Mouro
Tel.: (+351) 21 922 85 30
Fax : (+351) 21 922 85 36
info@gardena.pt

Romania
Madex International Srl
Soseaua Odaii 117 - 123,
RO 013603 București, S1
Phone: (+40) 21 352.76.03
madex@ines.ro

Russia / Россия
ООО „Хускварна“
141400, Московская обл.,
г. Химки,
улица Ленинградская,
владение 39, стр.6
Бизнес Центр
„Химки Бизнес Парк“,
помещение ОВ02_04
http://www.gardena.ru

Serbia
Domel d.o.o.
Autoput za Novi Sad bb
11273 Belgrade
Phone: (+381) 1 18 48 88 12
mironslav.jejina@domel.rs

Singapore
Hy-Ray PRIVATE LIMITED
40 Jalan Pemimpin
#02-08 Tat Ann Building
Singapore 577185
Phone: (+65) 6253 2277
shiyjing@hyray.com.sg

Slovak Republic
Husqvarna Česko s.r.o.
Türkova 2319/5b
149 00 Praha 4 – Chodov
Bezplatná infolinka:
800 154 044
servis@sk.husqvarna.com

Slovenia
Husqvarna Austria GmbH
Industriezeile 36
4010 Linz
Tel.: (+43) 732 77 01 01-485
service.gardena@
husqvarnagroup.com

South Africa
Husqvarna
South Africa (Pty) Ltd
Postnet Suite 250
Private Bag X6,
Cascades, 3202
South Africa
Phone: (+27) 33 846 9700
info@gardena.co.za

Spain
Husqvarna España S.A.
Calle de Rivas nº 10
28052 Madrid
Phone: (+34) 91 708 05 00
atencioncliente@gardena.es

Suriname
Agrofix n.v.
Verlengde Hogestraat #22
Phone: (+597) 472426
agrofix@sr.net
Pobox : 2006
Paramaribo
Suriname – South America

Sweden
Husqvarna AB
Gardena Division
S-561 82 Huskvarna
info@gardena.se

Switzerland / Schweiz
Husqvarna Schweiz AG
Consumer Products
Industriestrasse 10
5506 Mägenwil
Phone: (+ 41) (0) 62 887 37 90
info@gardena.ch

Turkey
GARDENA Dost Diş Ticaret
Müessesilik A.Ş.
Sanayi Cad. Adil Sokak
No: 1/B Kartal
34873 Istanbul
Phone: (+90) 216 38 93 939
info@gardena-dost.com.tr

Ukraine / Україна
ТОВ «Хусварна Україна»
вул. Васильківська, 34,
офіс 204-г
03022, Київ
Тел. (+38) 044 498 39 02
info@gardena.ua

Uruguay
FELI SA
Entre Ríos 1083 CP 11800
Montevideo – Uruguay
Tel : (+598) 22 03 18 44
info@felisa.com.uy

Venezuela
Corporación Casa y Jardín C.A.
Av. Caroni, Edif. Trezmen, PB.
Colinas de Bello Monte.
1050 Caracas.
Tlf : (+58) 212 992 33 22
info@casayjardin.net.ve

SG300EU-20.960.02/0321
Husqvarna AB
S-561 82 Huskvarna
Sweden

