



Original instructions in English. Any other language is a translation of the original instructions.

OPERATING INSTRUCTIONS BDC-99

VERSION 1.9





Inspection comments

Inspection before initial operation on:	_____
By:	_____
Date of initial operation:	_____
Serial number & Year of manufacture:	_____

Recurring inspections

Date / Hour counter	Findings	Repairs / Cleaning	Test on	By*

*competent person

Table of contents

Maintenance log	2
1. Introduction	4
2. Machine description	4
3. Safety	6
3.1 Work area safety	6
3.2 Electrical safety	6
3.3 Personal safety	7
3.4 Machine safety	7
3.5 Dust collector safety	7
3.6 Maintenance safety	8
3.7 Transport safety	9
3.8 Signs on the machine	10
4. Initial operation	11
4.1 Checkpoints of electrical safety	11
4.2 Checkpoints of machine safety	11
4.3 Control box	11
4.4 Transport	13
5. Operating	14
5.1 Before switch on	14
Extension lead	14
Checking & correcting the turning direction	14
5.2 Starting / stopping the machine	14
5.3 Working with the machine	14
5.4 Interrupting work	15
5.5 Emptying the dust bin	15
5.6 Replacing a bigbag	15
5.7 Silencer	16
6. Maintenance	16
6.1 When to change the filters	17
6.2 Changing the filters	18
6.3 Pulse system	19
6.4 Water separator	20
6.5 Compressor	20
6.6 The V-belts	21
6.7 V-belt mounting	21
6.8 V-belt tension	21
7. Special options	22
7.1 HEPA filter	22
7.2 Difference vacuum gauge	22
7.3 Horizontal in-line preseparator	23
8. Troubleshooting	24
9. Technical data	26
Contact	



1. Introduction

Before use, operators must be provided with information, instruction and training for the use of the machine and the substances for which it is to be used, including the safe method of removal and disposal of the material collected. All persons who are working with or maintaining this machine must read the manual carefully and understand it fully. In case you sell the unit, hand it on to the next owner. Keep this manual always with the machine, to enable it to be referred to at any time. Any other work not covered by this operating manual must not be carried out.

This machine is designed for industrial use by professionals. Only authorized and trained personnel may operate this machine. This machine is not intended for use by persons (including children) with reduced physical, sensory or mental capabilities, or lack of experience and knowledge. **Blastrac BV** offers a course on the use of the machine in order to make the operating and maintenance personnel familiar with all elements of the machine. Always use common sense when working with machines.

2. Machine description

The Blastrac dust collector BDC-99 may only be used in combination with Blastrac blast cleaning machines, grinders and scarifying machines. The BDC-99 can **only** be used for **dry cleaning**. It should **only be** used for removing **noncombustible/non-explosive dust or substances**. The BDC-99 must **not** be used for **pathogenic or carcinogenic substances like asbestos**. Do not use the machine in the presence of dangerous atmospheres. The machine is designed for usage in conditions according to classification **M** (see below).

Classification according to standard EN 60335-2-69 – Annexe AA	
Class	Designation
L	(light hazard) suitable for separating dust with a limit value of occupational exposure of greater than 1 mg/m ³ ;
M	(medium hazard) for separating dust with a limit value of occupational exposure not less than 0,1 mg/m ³
H	(high hazard) for separating all dusts with all limit values of occupational exposure, including carcinogenic and pathogenic dusts.

Dust emissions into the environment	
Class	Value of performance
L	Retains at least 99 % of Most Penetrating Particle Size (MPPS) 0.3 µm
M	Retains at least 99,9 % of Most Penetrating Particle Size (MPPS) 0.3 µm
H	Retains at least 99,995 % of Most Penetrating Particle Size (MPPS) 0.3 µm

In the case of dust harmful to health, contact the local health and safety authorities, and observe national regulations in force both during use and disposal.

In addition to the Operating Instructions general and legal regulations regarding accident prevention and environmental protection must be complied with and indicated!

Such duties may for example relate to the handling of hazardous substances or to the provision and wearing of personal protection equipment as well as compliance with local regulations.



Application

The BDC-99 is a very powerful mobile dust extractor. This high performance machine is exclusively designed and built to be used in combination with Blastrac machines. It is equipped with **9 pieces** of specially designed **high quality M-class cartridge filters**.

The dust extractor is provided with an air pulse cleaning system which increases the life of the filter cartridges. This system works by use of pressurized air, built up by a compressor. The air is led through a water separator to the pulse system.

The conditioned air then passes a control valve which regulates the system pressure, and then builds up pressure in the pulse tank. The pressurized air is used to generate a pulse of air which cleans the filters from the inside. With every pulse of the pulse system, dust and particles are released from the filter surface. Contact Blastrac B.V. for the correct execution and combinations.

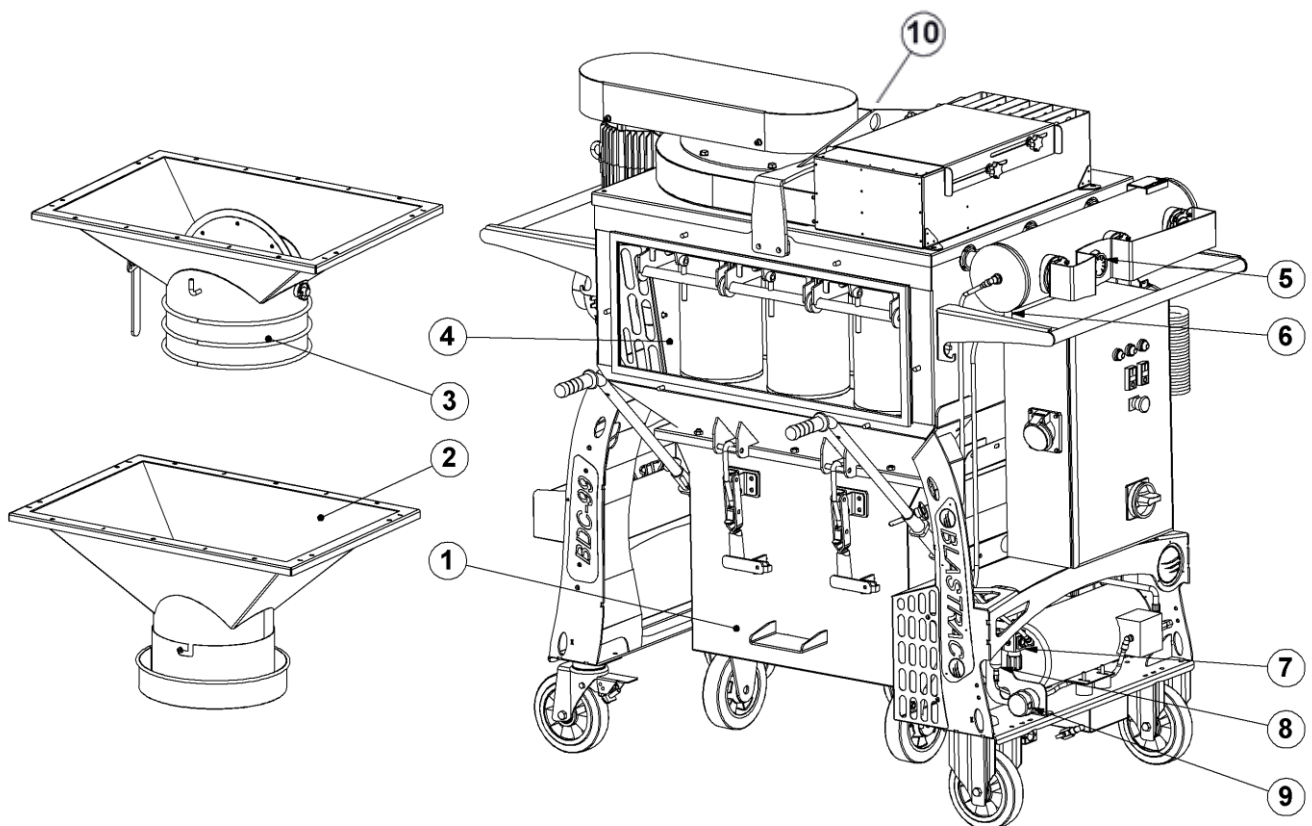

1	Dust bin kit	6	Drain valve. Open regularly to remove water from the air tank.
2	Longo pack kit	7	Pressure valve, must be set on 7 bar
3	Big bag kit	8	Water separator
4	Rubber impact plate	9	Air filters compressor
5	Manometer, shows the pressure of the air tank. The pulse to clean the filters must be given at 5 – 5.5 bar.	10	Lifting eye

3. Safety



Warning!

Read all safety warnings and all instructions. Failure to follow the warnings and instructions may result in electric shock, fire, explosions and / or serious injuries.

Only authorized and trained personnel may operate this machine. This machine is not intended for use by persons (including children) with reduced physical, sensory or mental capabilities, or lack of experience and knowledge.

It is the responsibility of the user to analyse the surface to be treated. The surface may not contain any substances which could pose a fire-, explosion- or health risk when treated. The user should make a risk assessment on the basis of the information obtained about the surface to be treated and take proper precautions for the work to be performed.

In case of any inappropriate usage, improper operation or repair, the producer shall be exempt from liability.

3.1 Work area safety

- a) Do not use the machine in rain, damp or wet locations.
- b) **Avoid dangerous environments:** do not work in the presence of explosive atmospheres, in the presence of flammable liquids, gases or dust. Remove materials or debris that may be ignited by sparks.
- c) Make sure there is enough ambient light on the work area. Cluttered or dark areas invite accidents.
- d) Only use the machine when it is parked on a flat, horizontal surface.
- e) Keep children and bystanders away while operating the machine. They are likely not to foresee the potential dangers of the machine. Distractions could cause you to lose control of the machine.
- f) Persons who are not operating the machine must not be permitted to stay in the surrounding area of at least 5 meter from the machine.
- g) Secure the work area around the machine in public areas providing an adequate safety distance from the machine. Use a red and white safety chain and danger sign to enclose the work area.
- h) It is necessary to provide for an adequate air change rate L in the room if the exhaust air is returned to the room. Comply with the National regulations.
- i) Never use the machine when the surface is not clear and if there is a risk of stumbling or tripping.
- j) Remove electrical cables and dust hose from the surface to be treated.
- k) Make sure that there are no cables or hoses in the driving direction of the machine.
- l) Make sure that there is nothing standing or situated on the surface to be treated.
- m) Make sure the machine can travel over all inequalities on the surface, small inequalities like weld seams or (floor) joints are no barriers for the machine.
- n) **Never operate the machine when workplace is wet. Never stay in the rain with the machine.**
- o) Check if there are any obstacles that can snag the cables when the machine is moving.
- p) **Warning!**
Make sure that the surface to be treated does not contain dangerous materials such as:
 - combustible or explosive dusts or substances.
 - carcinogenic or pathogenic substances.
In these cases, additional safety measures should be used. Always mind the local safety requirements. Contact your dealer for additional options.
- q) Secure the work area around the machine in public areas providing an adequate safety distance from the machine. Use a red and white safety chain and danger sign to enclose the work area.

3.2 Electrical safety

- a) Use only extension cables for extending the main cable that are sized and marked in accordance with the overall power consumption of the machine. **Do not use damaged extension cables.**
- b) Electrical cables must be rolled entirely off of the reels.
- c) Any damage to the electric cables and/or electrical components is not permitted.
- d) If the power supply cable or plug is damaged, it must be replaced immediately. Only use original Blastrac parts.
- e) The voltage on the identification plate must comply with the power supply.
- f) The extension lead may only be used for Blastrac machines with the correct power consumption.
- g) Use an electrical power supply connection with earth connection and earth leakage circuit breaker.
- h) The circuit breaker of the power supply must have a "D" characteristic. Circuit breakers with a "C" or "B" characteristic can give problems when switching the machine on.



- i) **Keep the machine original; The machine is always equipped with an earthed connection, do not change this** and always use earthed cables with an earthed plug.
- j) Inspect and test the electrical components regularly. The electrical components have to satisfy with the requirements set out in the harmonised norm EN-IEC 60204-1.
- k) Always call a skilled electrician or your distributor when you have questions about the safety of the electrical components.
- l) Work on electrical equipment or operating materials may only be undertaken by a skilled electrician or by trained persons under the guidance and supervision of a skilled electrician as well as in accordance with the electrical engineering regulations.
- m) Always use tools that are insulated against voltages.
- n) Do not abuse the cables. Never use the cables for carrying, pulling or unplugging the machine. Keep cables away from heat, oil, sharp edges or moving parts. Damaged or entangled cables increase the risk of electric shock. Do not fold the cable or clamp it.
- o) Don't pull out the power supply cable out by the wire, but by the connector.
- p) Be careful with water on the treated surface. Electrical cables must not come into contact with water.
- q) The main power switch on the machine must be in the "Off" position before connecting to the power supply.
- r) During a long standstill of the machine, pull out the main plug.
- s) If the machine is to be operated using power from a generator, the generator must be operated in accordance with the current legal regulations and directives in force. (this applies to the protective earth conductor in particular) in order to ensure that all safety devices are functioning and to eliminate possible damage to electrical components.

3.3 Personal safety

- a) **Always wear Personal Protective Equipment while working with the machine.**
 - Dust mask class FFP3 or higher
 - Ear protection
 - Safety glasses with lateral protection
 - Protecting gloves
 - Safety shoes
- b) Dress properly. Do not wear loose clothing or jewellery. Keep your hair, clothing and gloves away from moving parts!
- c) Personnel must tie back long hair and not wear loose clothing or jewellery including rings.
- d) Stay alert, watch what you are doing and use common sense when operating the machine.
- e) Always seek professional medical attention immediately in case of injury.
- f) All persons surrounding the machine should wear Personal Protective Equipment.

3.4 Machine safety general

- a) Safety functions and operating functions must work correct.
- b) No loose bolts and nuts permitted.
- c) Never operate machine without the guards and/or safety devices in place.
- d) Never change anything on the safety devices on the machine!
- e) Do not use the unit when it is damaged.
- f) Do not **open or remove protective guards** while driving gears are running.
- g) Hoses and pipe work can be under high pressure. The temperature can be above 37° C. Use only hoses and pipe work that are sized and marked in accordance with the machine's overall power consumption.
- h) The machine, specially the handle grips must be free of fats/oils and have to be dry.
- i) All repair work has to be done by qualified Blastrac personnel, this guarantees a safe and reliable machine.
- j) Always use original Blastrac spare parts and filters. This will ensure the best performance. Only original parts meet the factory specifications and quality. Otherwise Blastrac BV cannot guarantee the safety of the machine. The part numbers can be found in the Service Manual.
- k) Check the rotating direction of the motor before operation. The correct direction is given with an arrow on the housing of the motor.
- l) If safety-critical changes occur to the machine or its working method, the machine must be shut down immediately! The cause of the fault must be established, and rectified.
- m) In the event of operational malfunctions the machine must be shut down immediately and secured!



3.5 Dust collector safety

- a) The Blastrac dust collector can **only** be used for **dry cleaning**.
- b) It should **only** be used for removing **noncombustible/non-explosive dust or substances**.
- c) The machine may **not** be used for **pathogenic or carcinogenic or asbestos substances** without additional safety measures should be used. Always mind the local safety requirements. Contact your dealer for additional options.
- d) Do not use the machine in the presence of dangerous atmospheres like flammable gasses or dusts.
- e) The machine is designed for usage in conditions according to classification **M**.
- f) The dust hose must be undamaged and free of obstructions. It must be connected properly with hose clamps and industrial tape.
- g) Do not point hose at people or animals.
- h) Never use this machine for sucking water or liquids.
- i) Acids, acetone or solvents can damage the machine.
- j) Never use the machine without the filters in place!
- k) Never use the machine without a big bag/dustbin attached.
- l) Regularly check the contents of the dust-bin / bigbag. Always wear a **dust mask of at least class FFP3** when emptying the dust bin / changing the bigbag. Comply with the local waste treatment regulations considering the removed material.
- m) Regularly use the air pistol and drain valve to remove water from the pressure tank.
- n) When temporarily interrupting the work (1/2 hour – 1 hour), turn off the fan unit only. Pulse cleaning of the filter system will continue and will increase the life-time of the filter cartridges.
- o) During a longer stand still of the dust collector, first switch off the fan unit. Let the pulse cleaning cycle run for +/- 5 minutes. Switch off the compressor and Main-switch. Remove water from the air tank.
- p) Always close off the inlet of the dust collector when running the pulse cleaning cycle! Failure to do so results in blown out dust, which can be hazardous to the health!
- q) Close the sliding cover of the silencer when the machine is turned off. This prevents moisture, dust and other contaminants to enter the machine.
- r) If dust leaves the filter unit instead of clean air, this is a sign that the filter cartridges are damaged or not fixed correctly inside the chamber. Do not proceed! Rectify immediately!
- s) When a filter is leaking it has to be replaced. The compartment above the filters and silencer also have to be cleaned thoroughly.
- t) Compartments that are not dust-tight must be opened with suitable tools and thoroughly cleaned.
- u) Operators should observe all safety regulations appropriate to the materials being handled.
- v) Make sure the machine is parked on a flat and horizontal surface before operation.
- w) The machine must be braked by actuating the levers on the wheels with brakes.
- x) Do not allow the operation of the machine while it is moving, during operation the machine must be braked.

3.6 Maintenance safety

- a) Pull out the power plug and place it in sight, before starting inspections and repairing on the machine.
- b) Wait for standstill of all drives before any inspections, adjustments and/or maintenance work is started.
- c) Block machine in stable position before doing any maintenance work.
- d) Use the drain valve to depressurize the air pressure tank before maintenance.
- e) **WARNING!** Do not weld, flame cut or perform grinding works on or near the dust collector. Danger of fire or explosion exists!
- f) To allow the user to carry out maintenance operations, the dust collector must be disassembled, cleaned and inspected as far as reasonably possible, without causing hazards for the maintenance staff or other people.
- g) The suitable precautions include: decontamination before disassembling the dust collector, adequate filtered ventilation of the exhaust air from the room in which it is disassembled, cleaning of the maintenance area and suitable personal protection equipment.
- h) When maintenance or repair procedures are carried out, all the contaminated elements that cannot be properly cleaned, must be destroyed.
- i) These elements must be disposed of in sealed bags according to the applicable regulations and in accordance with the local laws governing the disposal of such material.
- j) This procedure must also be followed when the filters have to be disposed.
- k) Use only original Blastrac filters and spare parts.
- l) It is advisable to stock all spare parts or wear parts that cannot be supplied quickly. As a rule, production standstill periods are more expensive than the cost for the corresponding spare part.
- m) Failures due to inadequate or incorrect maintenance may generate very **high repair costs** and long standstill periods of the machine. **Regular** maintenance therefore is imperative.
- n) Operational safety and service life of the machine depends, among other things, on proper maintenance.



- o) Prevent premature wear by keeping the machine as dust free as possible. Clean the machine for this reason regularly with a dust collector and non-aggressive materials. Never use a high pressure water cleaner to clean the machine.
- p) The dust collector must be yearly overhauled by a skilled technician.

3.7 Transport safety

- a) Be aware of your surroundings and machine operating level. Do not side hill, do not run on steep incline, this could cause machine to tip over.
- b) Remove the dust from the dust collector before the dust collector is transported.
- c) Always dispose the contents of the dust collector before the end of the working day. Observe the local waste disposal regulations!
- d) Before the dust collector is removed from the hazardous zone, take precautions to prevent dust from escaping.
- e) For class H and M machines, the outside of the machine should be decontaminated by cleaning and vacuuming methods, de-dusted before being taken out from the hazardous zone. All parts of the dust collector must be considered as contaminated when they are removed from the hazardous zone and appropriate actions must be taken to prevent dust from dispersing.
- f) Always close the inlet of the dust collector with the appropriate plug when the dust hose is disconnected.
- g) Make sure the dust hoses are disconnected and put away properly before transport.
- h) The net weight of the BDC-99 is 510 kg. Use a crane or lift when transporting the machine, use the lifting eye of the machine.
- i) Before every use check the lifting eye and welds for: deformation, damages, cracks, corrosion and wear.
- j) Only lift the machine on the lifting eye (Page 5, item 10).
- k) When lifting the machine from the ground, always use the lowest lifting speed. The cables must first be tensioned at this speed; they must not be slack when the machine is lifted from the ground.
- l) During hoisting make sure to be at a safe distance from the machine with the most optimal view on the machine and working environment.
- m) Never stand directly below the machine.
- n) Never use the machine for lifting persons or items.
- o) When transporting the machine do so in such a manner that damage due to the effects of the use of force or incorrect loading and unloading is avoided.
- p) The lifting eye can also be used to fasten the machine on a pallet or during transport.
- q) Always drive backwards when driving up to a ramp or grade, and forwards when driving of the ramp.
- r) Chock wheels for transport, use the brakes on the wheels.
- s) Don't leave the machine unsecured on jobsites.
- t) Park the machine always on a flat horizontal and levelled surface.
- u) Make sure the electrical cable and dust hose are disconnected before transport.
- v) Never use the machine for lifting persons or items.
- w) Store the cleaned and dry machine in a humid free room. Protect the electrical motor from moisture, heat dust and shocks.



3.8 Signs on the machine

The following stickers are placed on the machine. Meanings of these symbols are:



! Danger Hazardous voltage in motor even when solid state controller is OFF. Disconnect main power before servicing motor, controller or associated wiring.



Lifting point.



Wear a dust mask class FFP2 or higher.

Hearing protection is obliged.

Safety glasses with lateral protection are obliged.

CE-mark on this machine.

Wear protecting gloves.

Safety shoes obliged.

Consult the manual before operating the machine.

Type plate:

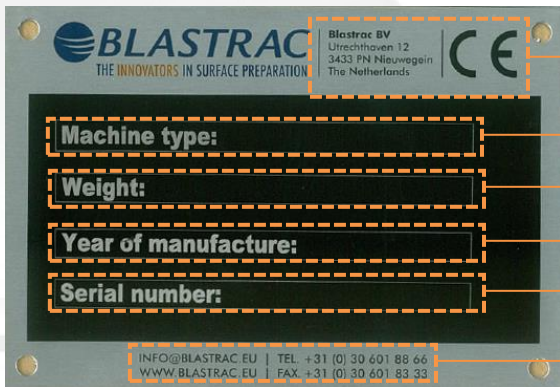

Name, address and CE mark.

The machine type.

The net weight of the machine in kilogram.

The year of manufacture.

The serial number of the machine.

Email address, Website, Telephone & fax number.

EU Declaration of Conformity:



4. Initial operation

Before using the machine it is essential to inspect the machine.

It is not permitted to use the machine if the machine safety is not according the checkpoints below.

4.1 Checkpoints power supply

- Use only extension cables for extending the main cable that are sized and marked in accordance with the overall power consumption of the machine.
- Electrical cables must be fully unwind of the reels.
- No damage is permitted for electrical cables.
- Use an electrical power supply connection with earth connecting.
- The main switch of the machine should be put to 'Off' before connecting to the power supply.
- Make sure the power supply is in accordance with the machine specifications.
- The circuit breaker of the power supply must have a 'D' characteristic. Circuit breakers with a 'C' or 'B' characteristic can give problems when switching the machine on.
- If the machine is to be operated using power from a generator, the generator must be operated in accordance with the current legal regulations and directives in force. (this applies to the protective earth conductor in particular) in order to ensure that all safety devices are functioning and to eliminate possible damage to electrical components.

4.2 Checkpoints of machine

- Safety functions and operating functions must work correct.
- Check all screws and other fasteners for tightness. No loose bolts and/or nuts are permitted.
- Check the electrical components, cables and connections for wear and/or damages.
- Dust hose connection must be reliable: use hose clamps and industrial tape.
- Dust hoses must be undamaged and free of obstructions.
- Make sure that the dust bin / bigbag is empty and connected properly.
- If dust leaves the filter unit instead of clean air, this is a sign that the filter cartridges are damaged or not fixed correctly inside the chamber. Do not proceed! Rectify immediately!
- All water must be removed from the air tank and drain box. Excessive water can have a negative impact on the pulse power and shortens the life-time of the filter cartridges.
- Check all air hoses for leakage.
- Make sure the machine is parked on a flat and horizontal surface before operation.
- The machine must be braked by actuating the levers on the wheels with brakes.
- Do not allow operation of the machine while it is moving, during operation the machine must be braked.

4.3 Control box

The control box is equipped with all control elements and instruments for monitoring and controlling the dust collector.

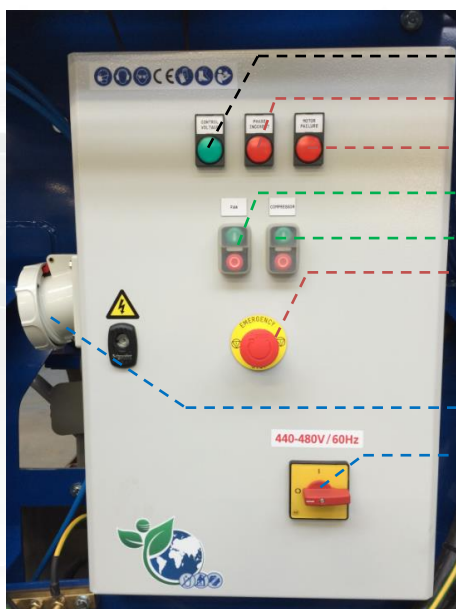

1	Control voltage light (green)
2	Phase sequence control light (red)
3	Motor failure control light (red)
4	Fan ON/OFF button
5	Compressor ON/OFF button
6	Emergency shutdown button
7	Extension lead (45A max.)
8	Main power switch



1. Control voltage light

When lit it indicates that the machine has power supply.

2. Phase sequence Control light

This light shines when the phases of the power supply are incorrect.

3. Motor failure Control light

This light shines when the whole electric system will be switched off due to an overload of one motor.

4. Button Fan ON/OFF

Pressing the green button switches the fan on. Pressing the red button switches the fan off. The fan can only be switched on when the compressor is switched on.

5. Button Compressor ON/OFF

Pressing the green button switches the compressor on. Pressing the red button switches the compressor off.

6. Emergency shutdown button

Red mushroom-shaped emergency shutdown push button, this button cuts off all power to the machine and the extension lead. Turn to unlock.

7. Extension lead

The extension lead on the vacuum cleaner may only be used as an extension lead for Blastrac machines. Contact Blastrac for the correct combinations.

The extension lead on the vacuum cleaner will only be live when the mains plug is plugged in, and the main power switch is turned ON. Connection value: Vacuum cleaner + connected unit, maximum 60A.

CAUTION! Machines must be switched off when they are connected.

8. Main power switch

The main power switch is located on the control box. It has to be switched ON before operating the dust collector and the use of the extension lead.

- **Phase inverter switch**

This switch is located inside the control box. It is used when the phases of the power supply are incorrect.

Set the main power switch in position "0" and open the control box door. Now you can adjust the turning direction of the motors with the phase inverter switch.

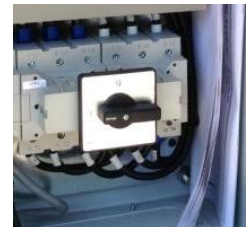

4.4 Transport

Read chapter 3.7 "Transport safety"

Be careful! Make sure nobody's feet get under the wheels. Wear appropriate safety shoes when you drive the machine to or from the work area.

Remove the dust from the dust collector before it is transported. The dust collector may only be lifted by using the suspension eyelet. The weight and dimensions of the dust collector are shown in Chapter 9 "Technical data".

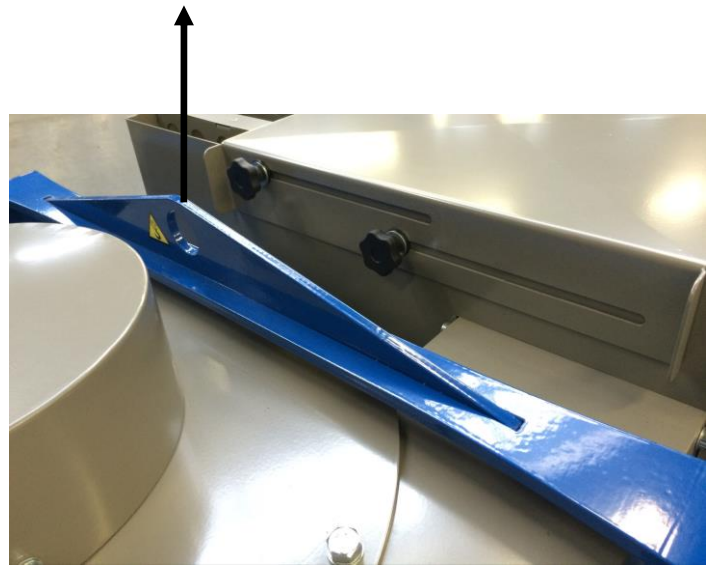

Make sure that no vehicles, such as forklift trucks and other equipment run over the electric cable and the dust hose.

The machine should only be moved around when the dust hose, and power supply cable are disconnected.

WARNING! Always make sure all rotating parts have come to a complete standstill and there is no more pressure in the air tank before moving the machine around.



5. Operation

Before switching on the machine make sure that no-one can be endangered when the machine starts up. Make sure that no vehicles, such as forklift trucks and other equipment run over the electric cable and the dust hose. Park the machine on a flat horizontal surface and put the brakes on.

5.1 Before switch on

Extension lead

The extension lead on the machine may only be used as an extension lead for Blastrac machines. Contact Blastrac for the correct combinations.

The extension lead on the vacuum cleaner will only be live when the mains plug is plugged in, and the main power switch is turned ON. Connection value: Vacuum cleaner + connected unit, maximum 60A.

CAUTION! Machines must be switched off when they are connected.

Checking the turning direction of the motors

- Start the machine for a few seconds by pressing the 'compressor ON' and 'fan ON' buttons.
- Stop the machine by pressing the 'fan OFF' and 'compressor OFF' buttons.
- Check the rotating direction of the fan motor (indicated with an arrow).

Correcting the turning direction of the motors

- Switch off all motors and put the main power switch to the OFF-position
- Wait for a complete standstill of all drives.
- Open the control box of the machine.
- Set the inverter switch to the opposite position.
- Close the control box and check the turning direction of the motor again.

5.2 Starting / stopping the machine

- Connect the dust hose between the machine to be used and the dust extractor.
- Connect the dust collector to the power supply.
- Switch on the main power switch.
- First switch on the compressor motor.
- Secondly switch on the fan motor.
- Carry out these actions in opposite sequence to stop the machine.

5.3 Work with the machine

- Regularly check the contents of the dust-bin or bigbag. Always wear a **dust mask of at least class FFP3** when emptying the dust bin or changing the bigbag. Observe and obey the local waste disposal regulations!
- Regularly open the drain valve to remove water from the air tank.



5.4 Interrupting work

- When temporarily interrupting the work (1/2 hour – 1 hour), turn off the fan motor only. Pulse cleaning of the filter system will continue and will increase the life-time of the filter cartridges.
- During a longer stand still of the dust collector, first switch off the fan unit. Let the pulse cleaning cycle run for +/- 5 minutes. Switch off the compressor unit and Main-switch.
- Disconnect the power-supply cable.
- Close the silencer when the machine is not working, so there is no change that water or dirt gets in.
- Prevent unauthorized persons from getting access to the dust collector or take measures to prevent unauthorized working with the equipment.

IMPORTANT NOTE !

Always close off the inlet of the dust collector when running the pulse cleaning cycle! Failure to do so results in blown out dust, which can be hazardous to the health !

5.5 Emptying the dust bin

Operators should observe all safety regulations appropriate to the materials being handled.

ATTENTION! Wear a dust mask of at least class FFP3!

The level of the dustbin must be regularly checked. The periods are dependent on the type of surface preparation being carried out.

WARNING: Pay attention to the increased weight of the dustbin when you loosen the hopper toggle clamps. Loosen the clamps with caution!

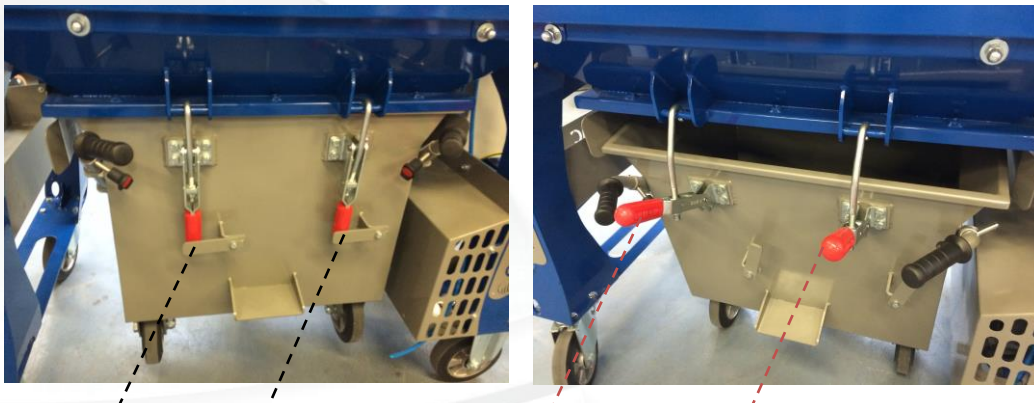

Flip the protectors up and grab the red handles of the toggle clamps. Carefully move them up until they can be unhooked. Remove and empty the dustbin.

5.6 Replacing a bigbag

ATTENTION! Wear a dust mask of at least class FFP3!

- 1 Close the butterfly valve with the control handle.
- 2 Remove and close the funnel of the BigBag.
- 3 Slide the bigbag off the support plate.
- 4 Place a new bigbag, sleeve the funnel on and secure it with the pull strap.
- 5 Open the butterfly valve with the control handle.

Description	Part number	Qty.
Big Bag 67,5 ltr	E06311	1
Big Bag 145 ltr	E09418	1
LongoPac cassette	BLS-1058	4x20mtr.

Close the BigBags properly and make sure they don't get punctured or ripped. A leaking BigBag can cause a big mess and potentially be dangerous to the health.

NOTE: The butterfly valve should always be opened during operation, only close it for changing the bigbag or transport.



5.7 Silencer

The silencer on top of the dust extractor reduces the noise emission but can also be used to adjust the suction power of the machine. Close it a little bit for less suction power, and open it for more suction power.

6. Maintenance

Pay attention to Chapter 3 "**Safety**" during maintenance and repair works.

Failures due to inadequate or incorrect maintenance may generate very **high repair costs** and long standstill periods of the dust collector. **Regular** maintenance therefore is imperative.

Operational safety and service life of the dust collector depend, among other things, on proper maintenance.

The following table shows recommendations about time, inspection and maintenance for the normal use of the dust collector.

Operating hours/ time period	Inspection points, maintenance instructions
12 h after repairing	Check all accessible screw connections for tight seat.
Daily and prior to starting work	Check that all safety devices working adequate. Check the electric connections for sediments of dirt or foreign bodies. Check the electric motors for dirt and other contaminants. Check all safety devices working adequate. Check the function of the residual current operated device. Check the hose connections for tightness and fixed seat. Check all hoses on the machine for damages or leakage. Make sure that the dust bin is emptied. Make sure there is no water in the air pressure tank.
Every 3 months	Clean the upper section of the filter unit. Clean or replace the air filter of the compressor. Clean or replace the filter inside the water separator. Check the tension of the V-belts.
Annually	Full overhaul and cleaning of the complete machine.

The time indications are based on uninterrupted operation. When the indicated number of working hours is not achieved during the corresponding period, the period can be extended. However a full overhaul and a technical inspection must be carried out at least once a year, consisting of inspection of filters for damage, air tightness of the machine and proper function of the control mechanism. This technical inspection shall be carried out by the manufacturer or an instructed person.

Due to different working conditions it can't be foreseen how frequently inspections for wear check's, inspection, maintenance and repair works ought to be carried out. Prepare a suitable inspection schedule considering your own working conditions and experience.

Pay attention to unusual noises or strong vibrations. Check for the cause of every big change. Call a technician if you have doubts about the cause or when a repair without a technician seems not possible without damages. Only use genuine Blastrac spare parts.

Our specialists will be happy to assist you with more advice.



Prior to any repair works on the dust collector and its drives, secure the dust collector against unintentional switching on. Put the dust collector to its safety off position. Also make sure there is no air pressure on the pulse system. The machine is in a safe condition when it cannot generate any hazard.

Follow additional operating and maintenance instructions of Original Equipment Manufacturers if included during your service and maintenance work.

Further is advised:

Store the cleaned and dry machine in a dry and humid free room. Protect the electrical motors from moisture, heat, dust and shocks.

All repair work must to be done by qualified Blastrac personnel, this to guarantee a safe and reliable machine.

Any guarantee on the machine is expired when:

- Non original Blastrac parts have been used
- Repair work is not done by qualified Blastrac personnel
- Changes, add on's or conversions are undertaken without written permission of Blastrac BV

Screws, bolts etc. that have been removed must be replaced with those of the same quality, strength, material and design.

Do not weld, flame cut or perform grinding works on or near the dust collector. Danger of fire or explosion exists! Provide adequate ventilation when working in a confined space. Secure the maintenance area if necessary.

6.1 When to change the filters?

If the dust collector loses suction power first try the following before continuing:

1. Check if the silencer is fully opened.
2. Ensure that the compressor is fully pressurized and then turn it off. Remove all moisture from the compressed air tank by using the drain valve. Turn on the compressor again until it is fully pressurized again, now use the air gun to completely empty the pulse tank.
3. Only turn on the compressor, and keep the fan unit turned off. Let the machine pulse for about a half an hour. This action will clean the filters from the inside.

When the machine still does not perform adequately, the filters probably need to be exchanged.

If the silencer blows out dust, stop the machine immediately!

This means probably that a filter is damaged or not fitted properly inside the filter chamber. Check the filters and replace if necessary.

When a filter was damaged, has leaked or was mounted incorrect, it has to be replaced. The compartment above the filters, the connecting air hoses and the silencer also have to be cleaned thoroughly.

Continuing work with a broken/leaking filter can cause serious damage to the machine and is a health hazard!

Never expose the filter cartridges to moisture!



Blastrac Cartridge Filter
IFA/BIA certificate M-class
Order nr. E10600



6.2 Changing the filters

Read chapter 3 Safety before changing the filters.

Operators should observe any safety regulations appropriate to the materials being handled.

Observe the national regulations in force both during exchange and disposal of the old filters.

Warning! Always wear Personal Protective Equipment, the dust can be hazardous to the health!

- Pull out the mains plug before you start
- Always wear gloves and a **dust mask** of at least **class FFP3**
- Use an extra vacuum cleaner in order to work as dust free as possible



Make sure you have enough sturdy plastic bags or use big bags for the disposal of the old filters. Observe the national regulations in force both during exchange and disposal of the old filters.

- 1: Locking bar
- 2: Nut + washer
- 3: Filter

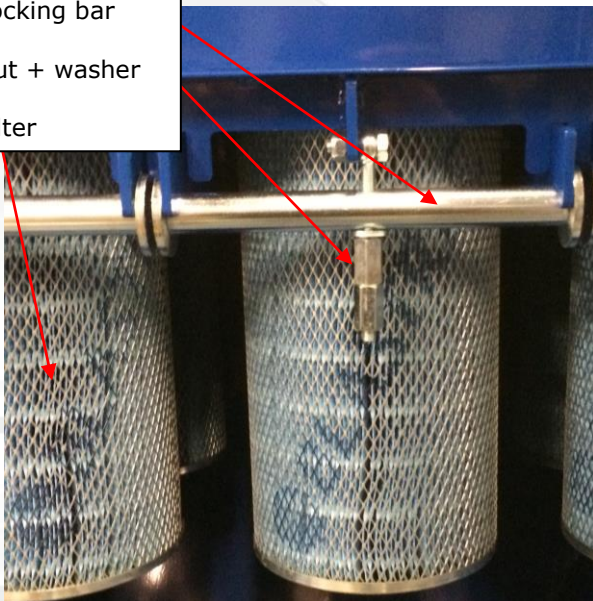

- Remove the filter house door.
- Loosen the nut + washer (2).
- Remove the locking bar (1).
- The filter bracket will now be tilted downwards so the filters can be taken out easily.
- Slide out the filter (3) and put it in a sturdy plastic bag.
- Close the bags properly.
- When mounting new filter cartridges pay attention that their gaskets at the upper side lies firm at the sheet steel of the filter chamber. A tilt of the filter cartridge results in leakage and contaminants will be sucked in the clean part and consequently will blow them backwards in the outer air.

When a filter was damaged, has leaked or was mounted incorrect, it has to be replaced. The compartment above the filters, the connecting air hoses and the silencer also have to be cleaned thoroughly.

If the silencer blows out dust, stop the machine immediately!

This means probably that a filter is damaged or not fitted properly inside the filter chamber.

Check the filters and replace if necessary.

Continuing work with a broken/leaking filter can cause serious damage to the machine and is a health hazard!



6.3 Pulse system

The Dust collector is provided with an air pulse cleaning system which increases the life of the filter cartridges and ensures a constant suction power.

The system works by use of pressurized air, built up by a compressor

The air is led through a water separator to the pulse system.

The cooled air passes a control valve, which regulates the systems pressure , and then builds up pressure in the pulse tank.

Normally the pressure in the system lies between 6 and 7 bar. The control valve is activated above 7 bar. This provision is to ensure that the pressure in the pulse tank remains within safe limits.

The safety valve mounted on the compressor is activated at approximately 10 bar.

This provision is to ensure that when there is a defect in the Control valve, the pressure in the pulse tank remains within safe limits.

If the pressure of 6 bar is not reached, it is possible that either the filter of the water separator or the air filter of the compressor is dirty.

If inspection of the water separator and compressor shows no abnormalities, it is possible that either there is a leakage in the air tubing, or the control valve is defect. In that case replace the defective parts or have it checked by Blastrac.

When there is pressure but the pulse system does not function, there might be a problem in the electrical system which controls the pulsing system. Check the wiring and the PLC-settings.

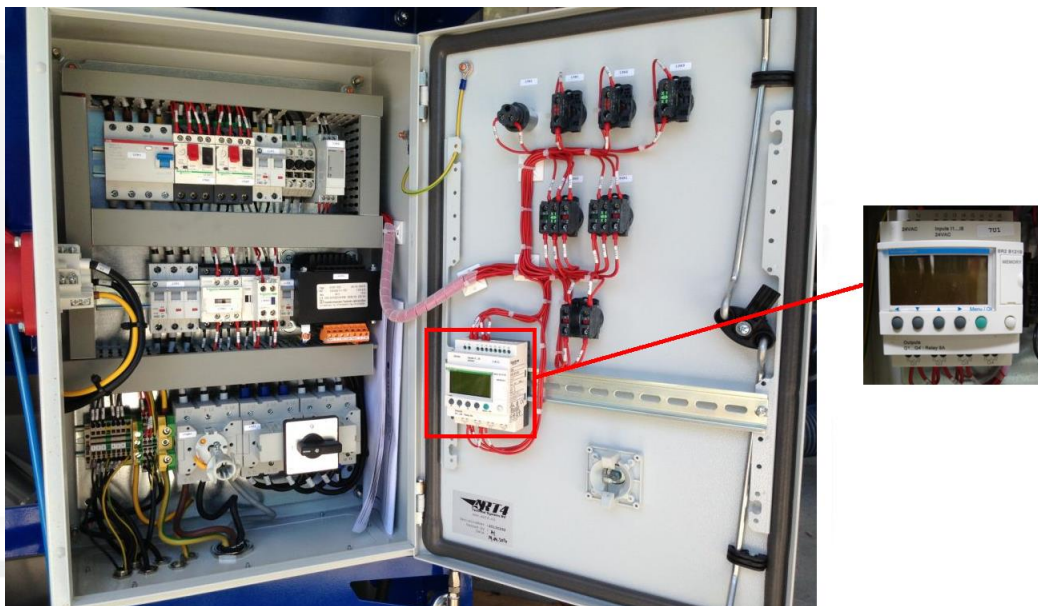

It is advised to contact Blastrac Support in order to prevent operational problems.

6.4 Water separator

The water separator filters dirt particles, oil and water from the air. It is recommended to replace the filter after every 200 operating hours.

1. Head
26. Valve
27. Floater
28. O-ring
29. Bowl
30. O-ring
31. Filter element
36. Louver

This spitter type drain operates momentarily when a rapid change in air flow occurs or when the supply pressure is reduced.

The separated water will be drained in the 'Drain Box'
It has to be emptied daily.

Checking the filter:

Unscrew 29. Bowl and keep it upright, so that the vlotter and o-ring will stay in place.
Check 31. Filter element on contaminants and calcium deposits.
Clean the filter with warm water and pressurised air or replace if needed.

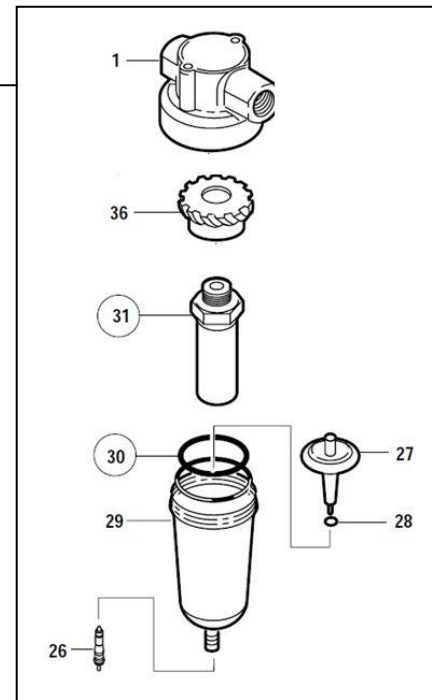

6.5 Compressor

Replacement or cleaning of the air filter of the compressor is depending on the environment in which the dust collector is operating.
Check the filter every month.

Unscrew the cap and take out the filter inside.
Clean or replace if necessary.

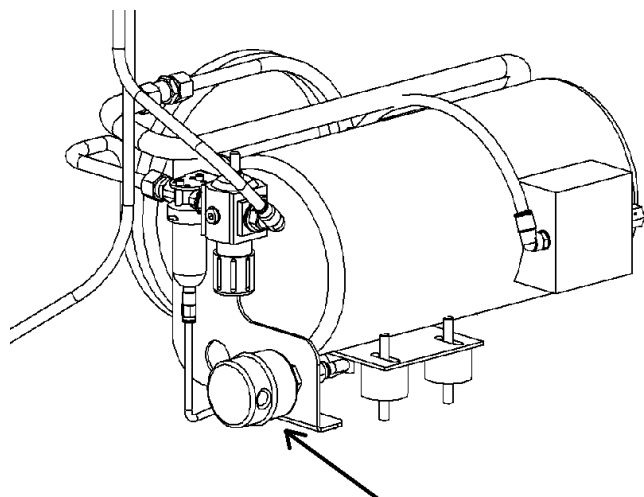



6.6 The V-belts

The V-belt drive is designed for the installed driving power. To force a higher output through an excessive high tension of the V-belts will result in broken belts, damage to the bearings and causes loss of the total efficiency. Too low belt tension will cause slipping with the result of a very high temperature of the V-belt and a premature destruction of it. Temperatures over 70° for a longer period will decrease the working life and the efficiency of the V-belts. The grooves of the V-belt pulleys must be free of rust, fat and dirt and must not show any damages. The use of belt wax or similar substances in order to increase the friction coefficient is not necessary and it damages the V-belts. Soiling due to oil, grease or chemicals have to be avoided.

In order to get perfect power transmission the V-belt drives have to be checked every 3 months.

6.7 V-belt mounting

Remove the belt guard only when the driving motor is in standstill and the power supply cable of the machine is disconnected from the power source.

- Reduce the distance between the driving motor and the bearing to release the tension of the V-belt drive.
- Carefully put the V-belt in the grooves of the V-belt pulley by hand and without using the force.
- Increase the distance between the driving motor and the bearing to stretch the V-belt as following described.
- Fix the required driving gear guards.

6.8 V-belt tension

The correct V-belt tension is of utmost importance in order to obtain a perfect power transmission and to reach the usual working life of the V-belt. Too low or too high tension causes frequently a premature breakdown of the V-belt. Excessive belt tension results in damaged bearings at drives.

Check the tension of the V-belt by pressing the thumb on the belt. The belt has the correct tension if you can press it in about 10-15 mm at approx. 10 kg. pressure.

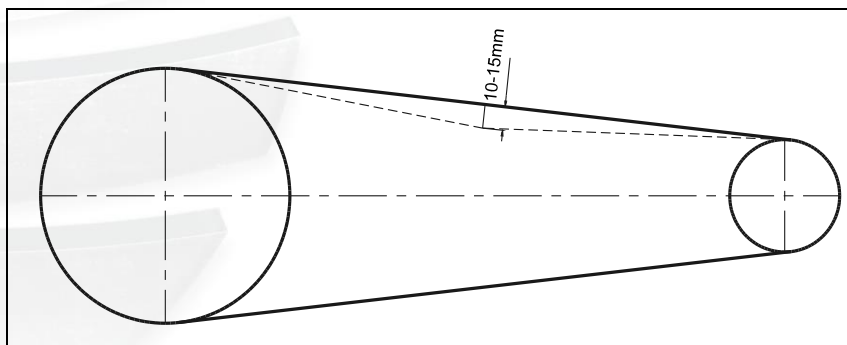

7. Special options

Blastrac offers a few special options. On request we have got advanced solutions for working conditions where the use of special equipment might be desired or required by law.

7.1 HEPA filter

The purpose of this option is to ensure clean air at the work space. This is achieved by using our high class HEPA filter. The Blastrac HEPA filters can be ordered in filter class H14

Our HEPA filters are tested according to EN 1822:2009 and classified H14 to test result.

Group	Filterclass	Total retention @ MPPS at least:	Local retention @ MPPS at least:	Total penetration @ MPPS	Local penetration @ MPPS
HEPA	H 14	99,995 %	99,975 %	0,005 %	0,025 %

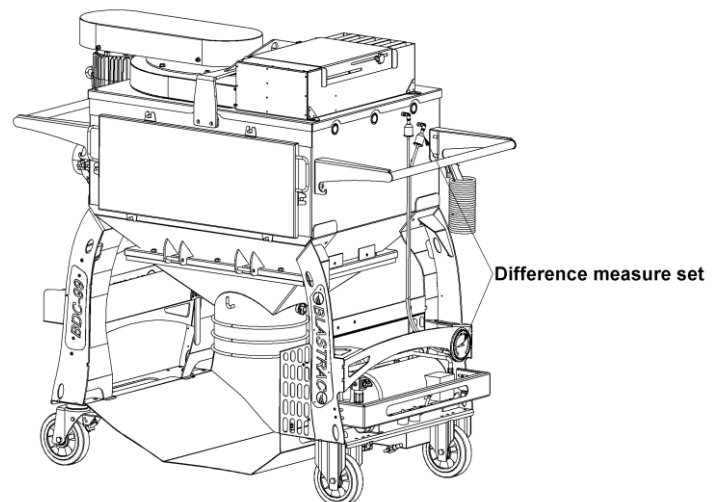
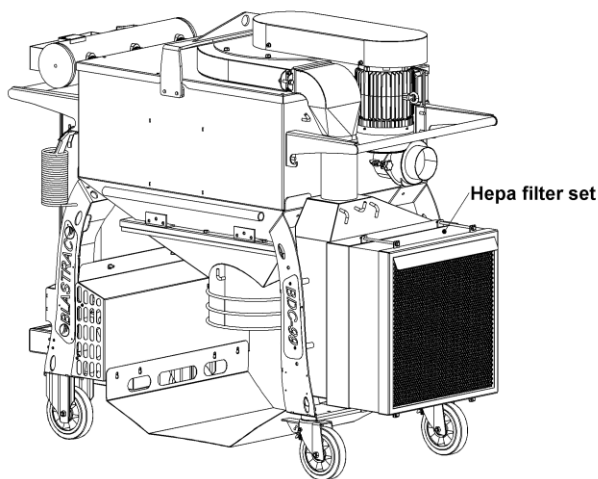

7.2 Difference vacuum gauge

A vacuum gauge measures the difference between the under pressure above the filters and inner filter house. This readout indicates the degree of pollution of the filters, with this system you can always keep an eye on the condition and pollution of the filters inside the dust extractor. It can also help you fine-tune the airflow when precise adjustment is required for the job.



7.3 Horizontal in-line preseparator

The horizontal in-line preseparator (E12278) can be used as an option for jobs with a lot of dust. The preseparator will separate +/-90% of the dust. This means that the dustcollector will last longer and stay more powerful. You will save precious time because the full bigbag underneath the preseparator can be replaced during work, the dustcollector does not have to be stopped.

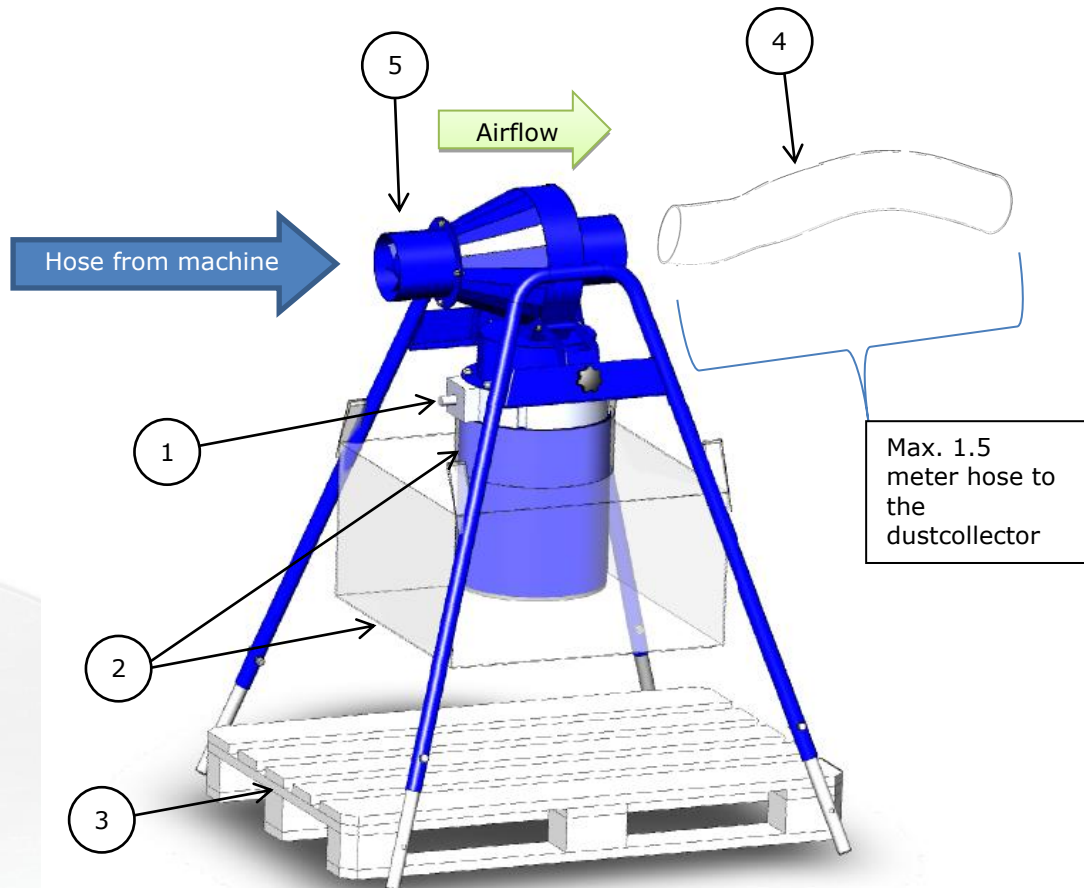

1. Connect the handle and make sure the valve is open.

2. Slide the big bag as high up as possible (as shown in the picture) and fasten with a strap or fixing belt.

3. Slide a pallet underneath.

4. Use 1.5 meter of Ø150 hose to connect to the dust collector.
Use tape or hose clamps (# 001109) to fasten the hose.

5. Connect the hose to the machine.
Use tape or hose clamps (# 001109) to fasten the hose.

6. Close the valve when changing a full big bag.

8. Troubleshooting

Prior to any repair works on the equipment or its drives the equipment must be secured against unintentional switching-on. Disconnect the power supply.

Fault	Possible cause	Remedy
Unusual noises	To little clearance or wrong adjustment of the rotating parts Too little grease in the bearing Silencer assembly defective	Check the alignment and adjustment of the rotating parts. Check screws and all parts for tight seat. Lubricate the bearing. Check and replace if needed.
Too low or no pressure	Check the whole pneumatic system for leaks. Dirty airfilter.	Fill the leaks or replace the damaged components. Clean or replace the air filter of the compressor.
Bad or no filter cleaning	Pressure too low. Pulse timer / PLC defective or wrong settings.	See above. Contact Blastrac.
No suction power	Dirty filter cartridges. Foreign air leaks in the dust container. Obstructed or ripped dust hose. Check the tension of the blower/fan V-belt.	Clean or replace the filter cartridges. Check the alignment or replace the seal. Check and replace if necessary. Adjust the tension of the V-belt.
Motor failure warning light is lit	The motor protection switch was triggered, for example: caused by wrong power supply or defective equipment.	Check the power supply for the correct voltage and Hertz. Call for a skilled electrician to check the motor protection switch inside the electrobox.
Phase sequence warning light is lit	The phases of the power supply are connected wrong.	Call for a skilled electrician to change the phase inversion switch inside the electrobox.

Note: If a motor protection switch has been triggered by overload, it can be switched on again after a short cooling down period.



Startup Problems

- If the light 'Failure' is lit up, a fault has been detected and the system has shut down.
- If the light 'Phase Incorrect' is lit up, the phases of the power connection are wrong.

Warning! Work on electrical equipment or operating materials may only be undertaken by a skilled electrician or by trained persons under the guidance and supervision of a skilled electrician as well as in accordance with the electrical engineering regulations.

The BDC-99's from serial number 28781B & up have a softstarter to protect the electrical equipment. On this softstarter the information regarding the failure is shown to help resolve problems.

The soft starter can be found in the electrobox.

The LED on the soft starter shows the problem in code:



LED OFF	Check power connections and power source
LED ON	Check isolation contactor for proper closure Check presence of line power
LED Flashing 1 x - Overload	Reset Overload
2 x - Over Temperature	Trip on Over Temperature. Allow time for unit to cool.
3 x - Phase Reversal	Check for proper phase rotation of line power
4 x - Phase Loss / Open Load	Confirm that 3-phase is present.
5 x - Phase Imbalance	Check line current present in each phase. Unit will trip if imbalance is >50%
6 x - Shorted SCR	Please contact your Blastrac dealer .

9. Technical data

	BDC-99 3x460 volt	BDC-99 3x400 volt
Power consumption	8,6 kW IE3	7,5 kW IE3
Electrical consumption	3x 460 Volt IE3	3x 400 Volt
Frequency	60 Hz	50 Hz
Amperage connection	63 Ampere	5 pole / 63 Ampere
Supply cable	4 x 16mm ² (15m)	4 x 16mm ² (15m)
Available plug connections	5 pole / 63 Ampere	5 pole / 63 Ampere
Air flow (with 20m hose 6" and medium shot blaster)	1410m ³ /hr	
Air flow without hose	2654m ³ /hr	
Vacuum	66 hPa / mbar	
Dust hose connection	Ø127mm / Ø150 mm	
Dust bin capacity	150L	
Longo pack capacity	25L	
Noise emission level	82dB(A) Uncertainty: 2,5dB	
Sound power level	96dB(A) Uncertainty: 2,5dB	
Dust bag	67,5L / 145L	
Length	1731mm	
Width	866mm	
Height	1643mm	
Weight	510kg	

Design and specifications are subject to change without notice by Blastrac B.V.
The electrical diagrams of the electrical system are placed inside of the control panel.

Extension cables

Cable length	Cross section			
	≤ 16 A	≤ 32 A	≤ 63 A	≤ 125 A
Calculated at a pre-fuse GG:	16amp*	32amp*	63amp*	125amp*
> 20m	1.5 mm ²	2.5 mm ²	10 mm ²	25 mm ²
20m > 50m	2.5 mm ²	4 mm ²	10 mm ²	25 mm ²
50m > 75m	4 mm ²	6 mm ²	16 mm ²	35 mm ²

*The cross-sections need to be re-calculated when using any other type or size pre-fuse than mentioned.

**IMPORTANT NOTES:**

The indicated values are measured on new machines. Noise levels will vary in different circumstances. Area influences like open outside or closed inside space, ambient temperature, different surfaces to be treated, daily use, different tools or accessories, poor maintenance, etc. will give different values at all time and could increase the exposure level over the total working period.

The declared noise emission level represents the main application of the machine. The values may be measurements from a representative sample of technically comparable machinery. The values may be used for a preliminary assessment of exposure.

A precise estimation of the level of exposure to noise should also take in account the fact that the dust collector does not require constant operating. Most of the times the operator won't be near the machine during normal activities. This may significantly decrease the exposure level over the total working period.

Identify additional safety measures to protect the operator from the effects of noise such as: proper and regular maintenance of the machine and the accessories, provision of proper ear protection and organization of work patterns for example by using rotation schedules.

Always use hearing protection when working with this machine.

Old equipment contains valuable materials which are valuable for re-processing. **The machine parts must not be thrown away in the normal household waste**, but should be disposed of at a suitable proper collection system, e. g. via your communal disposal location. This way the materials can be re-used in an environmentally responsible manner.

Despite the fact that this guide is made with care, Blastrac takes no liability for errors in the manual and the possible consequences. We are naturally very interested in your findings and additions.
No part of this publication may be reproduced and / or published in print, photocopy, or other form without prior permission by Blastrac.



BLASTRAC EUROPE

WE'RE READY TO ASSIST YOU!

BLASTRAC THE NETHERLANDS

EUROPEAN HEAD OFFICE
Utrechthaven 12
NL - 3433 PN Nieuwegein
Tel.: +31 (0)30 601 88 66
Fax: +31 (0)30 601 83 33
Email: info@blastrac.nl
WWW.BLASTRAC.EU

BLASTRAC POLAND

SALES & SERVICE CENTRE
Golina, ul. Dworcowa 47E
63-200 Jarocin
Tel.: +48 (0)62 740-41-50
Fax: +48(0)62 740-41-51
Email: info@blastrac.pl
WWW.BLASTRAC.PL

BLASTRAC FRANCE

SALES & SERVICE CENTRE
ZI - 29, Av. des Temps Modernes
F - 86360 Chasseneuil du Poitou
Tel.: +33 (0)5 49 00 49 20
Fax: +33 (0)5 49 00 49 21
Email: info@blastrac.fr
WWW.BLASTRAC.FR

BLASTRAC ITALY

SALES & SERVICE CENTRE
S.S. 10 Padana Inferiore, 41
IT - 29012 Caorso (PC)
Tel.: +39 0523 814241
Fax: +39 0523 814245
Email: info@blastrac.it
WWW.BLASTRAC.IT

BLASTRAC GERMANY

SALES & SERVICE CENTRE
Richard-Byrd-Str. 15
50829 Köln
Tel.: +49 (0) 221 709032-0
Fax: +49 (0) 221 709032-22
Email: info@blastrac.de
WWW.BLASTRAC.DE

BLASTRAC UKRAINE

SALES & SERVICE CENTRE
Nezalezhnosti 14, of. 21
07400 Brovary
Tel.: +38 (0)44 222 51 28
Fax: +38 (0)44 277 98 29
Email: info@blastrac.com.ua
WWW.BLASTRAC.COM.UA

BLASTRAC SPAIN

SALES & SERVICE CENTRE
Calle del Estío, 9
E - 28500
Arganda del Rey, Madrid
Tel.: +34 91 660 10 65
Fax: +34 91 672 72 11
Email: info@blastrac.es
WWW.BLASTRAC.ES

BLASTRAC UNITED KINGDOM

SALES & SERVICE CENTRE
Unit 2a, Outgang Lane, Dinnington
Sheffield, South Yorkshire
GB - S25 3QU
Tel.: +44 (0) 1909 / 569 118
Fax: + 44 (0) 1909 / 567 570
Email: info@blastrac.co.uk
WWW.BLASTRAC.CO.UK

BLASTRAC MIDDLE EAST

SALES & SERVICE CENTRE
P.O. box 29424
Dubai / United Arab Emirates
Tel.: +971 4 3245760
Fax: +971 4 3245761
Email: info@blastracdx.ae
WWW.BLASTRAC.AE

BLASTRAC NORDIC

SALES & SERVICE CENTRE
Lekstorps Industriväg 13D,
443 41, Gråbo
Sweden
Tel.: +46 (0) 31 30 333 55
Email: info@blastrac.se
WWW.BLASTRAC.SE

BLASTRAC INDIA

SALES & SERVICE CENTRE
G.B. Warehousing, GAT NO- 523,
Pune- Nagar Road, Wagholi
Pune- 412 207
Tel.: +91 99213 98109
Email: info.blastrac.in
WWW.BLASTRAC.IN