

SmallCut 300
SmallCut Plus 350

Art. 9805
Art. 9806

EN **Operator's manual**
Turbotrimmer

| |
|---|
| <p>DE Produkthaftung Wir weisen ausdrücklich darauf hin, dass wir in Übereinstimmung mit dem Produkthaftungsgesetz nicht für Schäden haften, die durch unsere Produkte entstehen, wenn diese unsachgemäß und nicht durch einen von uns autorisierten Servicepartner repariert wurden oder wenn keine Original GARDENA Teile oder von uns zugelassene Teile verwendet wurden.</p> |
| <p>EN Product liability In accordance with the German Product Liability Act, we hereby expressly declare that we accept no liability for damage incurred from our products where said products have not been properly repaired by a GARDENA-approved service partner or where original GARDENA parts or parts authorised by GARDENA were not used.</p> |
| <p>FR Responsabilité Conformément à la loi relative à la responsabilité du fait des produits défectueux, nous déclarons expressément par la présente que nous déclinons toute responsabilité pour les dommages résultant de nos produits, si lesdits produits n'ont pas été correctement réparés par un partenaire d'entretien agréé GARDENA ou si des pièces d'origine GARDENA ou des pièces agréées GARDENA n'ont pas été utilisées.</p> |
| <p>NL Productaansprakelijkheid Conform de Duitse wet inzake productaansprakelijkheid verklaren wij hierbij uitdrukkelijk dat wij geen aansprakelijkheid aanvaarden voor schade ontstaan uit onze producten waarbij deze producten niet zijn gerepareerd door een GARDENA-erkende servicepartner of waarbij geen originele GARDENA-onderdelen of onderdelen die door GARDENA zijn goedgekeurd zijn gebruikt.</p> |
| <p>SV Produktansvar I enlighet med tyska produktansvarslagar förklarar vi härmed uttryckligen att vi inte åtar oss något ansvar för skador som orsakas av våra produkter där produkterna inte har genomgått korrekt reparation från en GARDENA-godkänd servicepartner eller där originaldelar från GARDENA eller delar godkända av GARDENA inte använts.</p> |
| <p>DA Produktansvar I overensstemmelse med den tyske produktansvarslov erklærer vi hermed udtrykkeligt, at vi ikke påtager os noget ansvar for skader på vores produkter, hvis de pågældende produkter ikke er blevet repareret korrekt af en GARDENA-godkendt servicepartner, eller hvor der ikke er brugt originale GARDENA-reservedele eller godkendte reservedele fra GARDENA.</p> |
| <p>FI Tuotevastuu Saksan tuotevastuulain mukaisesti emme ole vastuussa laitteiden vaurioista, jos korjauksia ei ole tehnyt GARDENA:n hyväksymä huoltoliike tai jos niiden syynä on muiden kuin alkuperäisten GARDENA-varaosien tai GARDENA:n hyväksymien varaosien käyttö.</p> |
| <p>IT Responsabilità del prodotto In conformità con la Legge tedesca sulla responsabilità del prodotto, con la presente dichiariamo espressamente che decliniamo qualsiasi responsabilità per danni causati dai nostri prodotti qualora non siano stati correttamente riparati presso un partner di assistenza approvato GARDENA o laddove non siano stati utilizzati ricambi originali o autorizzati GARDENA.</p> |
| <p>ES Responsabilidad sobre el producto De acuerdo con la Ley de responsabilidad sobre productos alemana, por la presente declaramos expresamente que no aceptamos ningún tipo de responsabilidad por los daños ocasionados por nuestros productos si dichos productos no han sido reparados por un socio de mantenimiento aprobado por GARDENA o si no se han utilizado piezas originales GARDENA o piezas autorizadas por GARDENA.</p> |
| <p>PT Responsabilidade pelo produto De acordo com a lei alemã de responsabilidade pelo produto, declaramos que não nos responsabilizamos por danos causados pelos nossos produtos, caso os tais produtos não tenham sido devidamente reparados por um parceiro de assistência GARDENA aprovado ou se não tiverem sido utilizadas peças GARDENA originais ou peças autorizadas pela GARDENA.</p> |
| <p>PL Odpowiedzialność za produkt Zgodnie z niemiecką ustawą o odpowiedzialności za produkt, niniejszym wyraźnie oświadczamy, że nie ponosimy żadnej odpowiedzialności za szkody poniesione na skutek użytkowania naszych produktów, w przypadku gdy naprawa tych produktów nie była odpowiednio przeprowadzana przez zatwierdzonego przez firmę GARDENA partnera serwisowego lub nie stosowano oryginalnych części GARDENA albo części autoryzowanych przez tę firmę.</p> |
| <p>HU Termékszavatosság A németországi termékszavatossági törvénnyel összhangban ezennel nyomatékosan kijelentjük, hogy nem vállalunk felelősséget a termékeinkben keletkezett olyan károkért, amelyek valamely GARDENA által jóváhagyott szervizpartner által nem megfelelően végzett javításból adódtak, vagy amely során nem eredeti GARDENA alkatrészeket vagy a GARDENA által jóváhagyott alkatrészeket használtak fel.</p> |
| <p>CS Odpovědnost za výrobek V souladu s německým zákonem o odpovědnosti za výrobek tímto výslovně prohlašujeme, že nepřijímáme žádnou odpovědnost za poškození vzniklá na našich výrobcích, kdy zmíněné výrobky nebyly řádně opraveny schváleným servisním partnerem GARDENA nebo kdy nebyly použity originální náhradní díly GARDENA nebo náhradní díly autorizované společností GARDENA.</p> |
| <p>SK Zodpovednosť za produkt V súlade s nemeckými právnymi predpismi upravujúcimi zodpovednosť za výrobok týmto výslovné prehlasujeme, že nenesieme žiadnu zodpovednosť za škody spôsobené našimi výrobkami, v prípade ktorých neboli náležité opravy vykonané servisným partnerom schváleným spoločnosťou GARDENA alebo neboli použité diely spoločnosti GARDENA alebo diely schválené spoločnosťou GARDENA.</p> |
| <p>EL Ευθύνη προϊόντος Σύμφωνα με τον γερμανικό νόμο περί Ευθύνης για τα Προϊόντα, με το παρόν δηλώνουμε ρητώς ότι δεν αποδεχόμαστε καμία ευθύνη για τυχόν ζημιές που προκύπτουν από τα προϊόντα μας εάν αυτά δεν έχουν επισκευαστεί σωστά από κάποιον εγκεκριμένο συνεργάτη επισκευών της GARDENA ή εάν δεν έχουν χρησιμοποιηθεί αυθεντικά εξαρτήματα GARDENA ή εξαρτήματα εγκεκριμένα από την GARDENA.</p> |
| <p>SL Odgovornost proizvajalca V skladu z nemškimi zakoni o odgovornosti za izdelke, izrecno izjavljajo, da ne sprejemamo nobene odgovornosti za škodo, ki jo povzročijo naši izdelki, če teh niso ustrezno popravili GARDENINI odobreni servisni partnerji ali pri tem niso bili uporabljeni originalni GARDENINI nadomestni deli ali GARDENINIMI homologiranimi nadomestnimi deli.</p> |
| <p>HR Pouzdanost proizvoda Sukladno njemačkom zakonu o pouzdanosti proizvoda, ovime izričito izjavljujemo kako ne prihvaćamo nikakvu odgovornost za oštećenja na našim proizvodima nastala uslijed neispravnog popravka od strane servisnog partnera kojeg odobrava GARDENA ili uslijed nekorištenja originalnih GARDENA dijelova ili dijelova koje odobrava GARDENA.</p> |
| <p>RO Răspunderea pentru produs În conformitate cu Legea germană privind răspunderea pentru produs, declarăm în mod expres prin prezentul document că nu acceptăm nicio răspundere pentru defecțiunile suferite de produsele noastre atunci când acestea nu au fost reparate în mod corect de un atelier de service partener, aprobat de GARDENA, sau când nu au fost utilizate piese GARDENA originale sau piese autorizate de GARDENA.</p> |
| <p>BG Отговорност за вреди, причинени от стоки Съгласно германския Закон за отговорността за вреди, причинени от стоки, с настоящото изрично декларираме, че не носим отговорност за щети, причинени от нашите продукти, ако те не са били правилно ремонтирани от одобрен от GARDENA сервиз или ако не са използвани оригинални части на GARDENA или части, одобрени от GARDENA.</p> |
| <p>ET Tootevastutus Vastavalt Saksamaa tootevastutusseadusele deklareerime käesolevaga selgesõnaliselt, et me ei kanna mingisugust vastutust meie toodetest tingitud kahjude eest, kui need tooted ei ole korrektselt parandatud GARDENA heakskiidetud hoolduspartneri poolt või kui parandamisel ei ole kasutatud GARDENA originaalosi või GARDENA volitatud osi.</p> |
| <p>LT Gaminio patikimumas Mes aiškiai pareiškiame, kad, atsižvelgiant į Vokietijos gaminių patikimumo įstatymą, nepriisiame atsakomybės dėl bet kokios žalos, patirtos dėl mūsų gaminių, jeigu jie buvo netinkamai taisomi arba jų dalys buvo pakeistos neoriginaliomis GARDENA dalimis ar nepatvirtintomis dalimis, arba jeigu remonto darbai buvo atliekami ne GARDENA techninės priežiūros centro specialistų.</p> |
| <p>LV Atbildība par produkcijas kvalitāti Saskaņā ar Vācijas likumu par atbildību par produkcijas kvalitāti ar šo mēs paziņojam, ka neuzņemamies atbildību par bojājumiem, kas radušies, lietojot mūsu izstrādājumus, kuru remontu nav veicis uzņēmuma GARDENA apstiprināts apkopes partneris vai kuru remontam netika izmantotas oriģinālās GARDENA detaļas vai detaļas, kuru lietošanu apstiprinājis uzņēmums GARDENA.</p> |

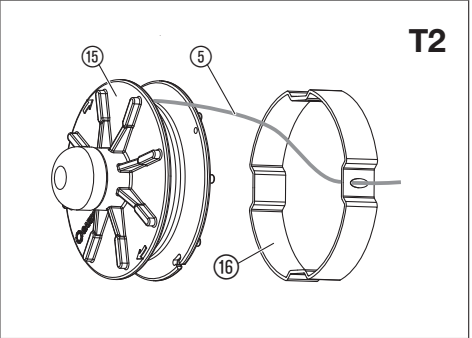
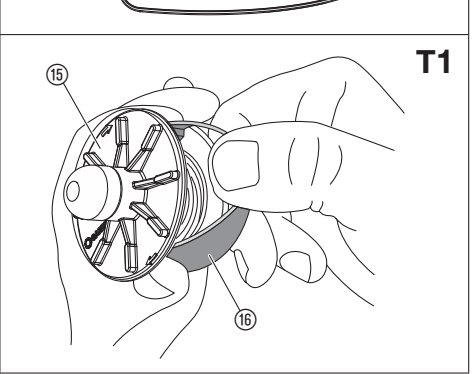
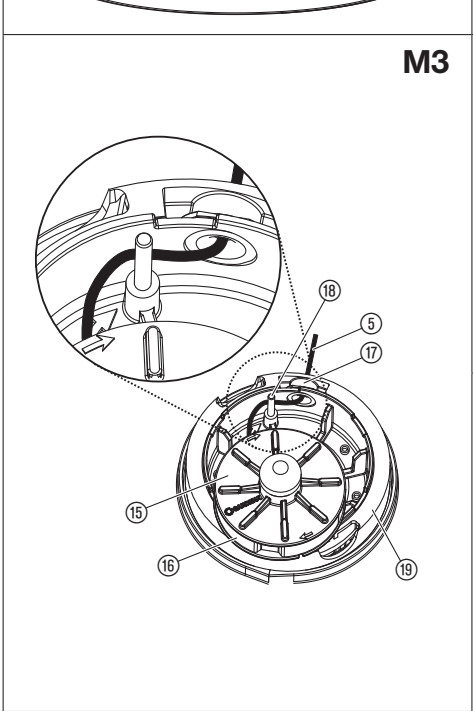
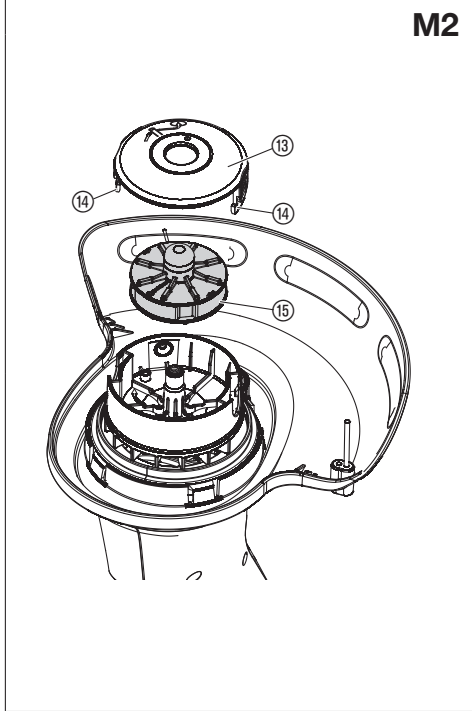
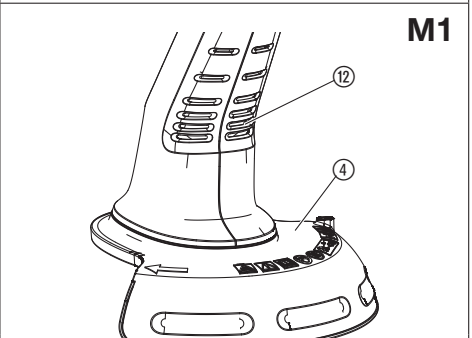
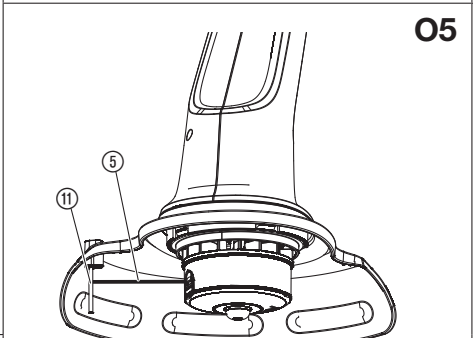
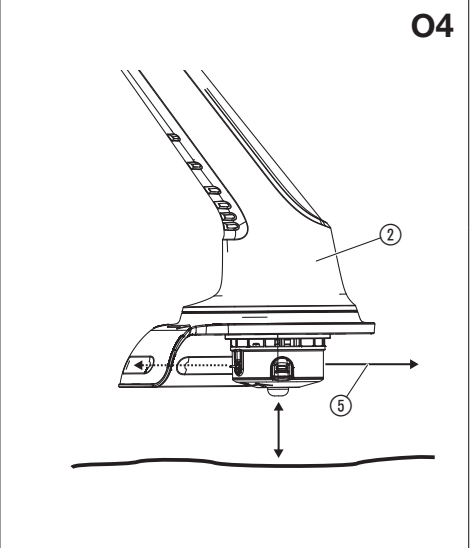
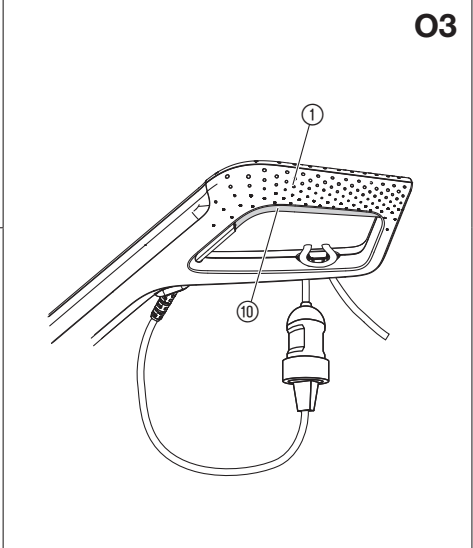
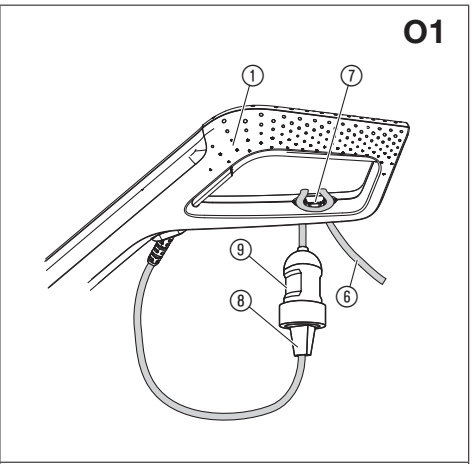
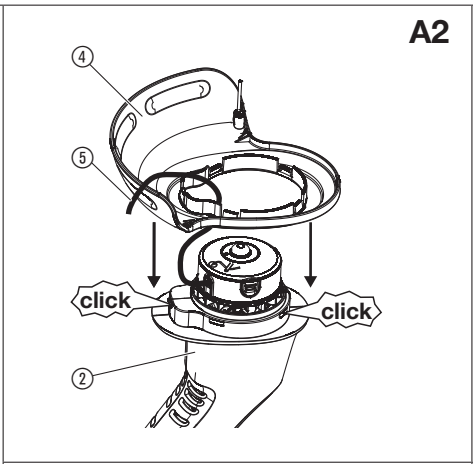
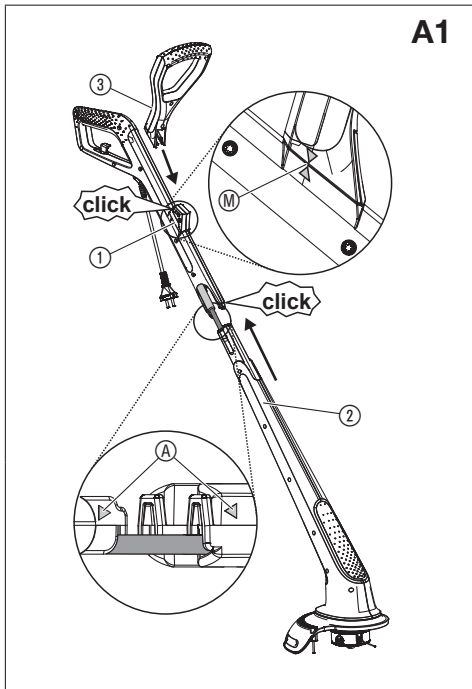

EN Turbotrimmer

| | |
|---------------------------|---|
| 1. SAFETY | 7 |
| 2. ASSEMBLY | 8 |
| 3. OPERATION | 8 |
| 4. MAINTENANCE | 8 |
| 5. STORAGE | 8 |
| 6. TROUBLESHOOTING | 9 |
| 7. TECHNICAL DATA | 9 |
| 8. ACCESSORIES | 9 |
| 9. SERVICE/WARRANTY | 9 |

Original instructions.

 This product may be used under supervision, or if instruction regarding the safe use of the product has been provided and the resulting dangers have been understood, by children aged 8 and above, as well as by persons with physical, sensory or mental disabilities or a lack of experience and knowledge. Children must not be allowed to play with the product. Cleaning and user maintenance must not be performed by children without supervision. The use of this product by young people under the age of 16 is not recommended. Never operate the product when you are tired, ill or under the influence of alcohol, drugs or medicine.

Intended use:

The **GARDENA Turbotrimmer** is used to trim and to cut grass and lawns in private house and hobby gardens.

Do not use the product in public facilities, parks, sports grounds, adjacent to roads or in agriculture or forestry.

 **DANGER! Risk of injury!**

→ Do not use the product to cut hedges, to shred or to make compost.

1. SAFETY

Important!

Read the operator's manual carefully before use and keep for future reference.

Symbols on the product:



Read operator's manual.



Keep other persons away.

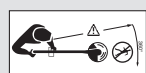

DANGER!
Risk of injury to other persons!

→ Keep other persons out of the work area.



Wear safety glasses and ear protection.



Do not let the product become wet with rain or other moisture. Do not leave the product outdoors while it is raining.



Disconnect the mains cable if the cable becomes damaged or entangled.

Safe operating practices

Training

- Read the instructions carefully. Be familiar with the controls and the correct use of the machine.
- Never allow children or people unfamiliar with these instructions to use the machine. Local regulations can restrict the age of operator.
- Keep in mind that the operator or user is responsible for accidents or hazards occurring to other people or their property.

Preparation

- Before use check the supply and extension cord for signs of damage or aging. If the cord becomes damaged during use, disconnect the cord from the supply immediately.
DO NOT TOUCH THE CORD BEFORE DISCONNECTING THE SUPPLY. Do not use the machine if the cord is damaged or worn.
- Before use, always visually inspect the machine for damaged, missing or misplaced guards or shields.
- Never operate the machine while people, especially children, or pets are nearby.

Operation

- Keep supply and extension cords away from cutting means.
- Wear eye protection and stout shoes at all times while operating the machine.
- Avoid using the machine in bad weather conditions especially when there is a risk of lightning.
- Use the machine only in daylight or good artificial light.
- Never operate the machine with damaged guards or shields or without guards or shields in place.
- Switch on the motor only when the hands and feet are away from the cutting means.
- Always disconnect the machine from the power supply (i.e. remove the plug from the mains, remove the disabling device or removable battery).
 - whenever the machine is left unattended;
 - before clearing a blockage;
 - before checking, cleaning or working on the machine;
 - after striking a foreign object;
 - whenever the machine starts vibrating abnormally.
- Take care against injury to feet and hands from the cutting means.
- Always ensure that the ventilation openings are kept clear of debris.

Maintenance and storage

- Disconnect the machine from the power supply (i.e. remove the plug from the mains, remove the disabling device or removable battery) before carrying out maintenance or cleaning work.
- Use only the manufacturer's recommended replacement parts and accessories.
- Inspect and maintain the machine regularly. Have the machine repaired only by an authorized repairer.
- When not in use, store the machine out of reach of children.

Recommendation

The machine should be supplied via a residual current device (RCD) with a tripping current of not more than 30 mA.

Additional Safety Recommendations

DANGER! Small parts can be easily swallowed. There is also a risk that the poly-bag can suffocate toddlers. Keep toddlers away when you assemble the product.

DANGER! When wearing hearing protection, and due to the noise produced by the product, the operator may not notice persons approaching.

If the product starts unintentionally when the mains plug is connected, disconnect the mains at once. Contact GARDENA Service to check the product.

DANGER! This product makes an electromagnetic field while it operates. This field may under some conditions interfere with active or passive medical implants. To decrease the risk of conditions that can possibly injure or kill, we recommend persons with medical implants to speak with their physician and the medical implant manufacturer before you operate the product.

Cables

Use only permitted extension cables as per HD 516.

→ Ask your electrical specialist.

If the product got hot during operation, let it cool down before storage.

2. ASSEMBLY



DANGER! Risk of injury!

Cut injury when the product starts accidentally.

→ Before you assemble the product, make sure that the mains cable is disconnected.

To assemble the trimmer [Fig. A1/A2]:

1. Put the top part of the handle ① and the trimmer head ② together until they make a click (**click**). Ensure that the two arrows ③ face each other. The cable must not be stretched or caught when you do this.
2. Put the bottom handle ③ on the top part of the handle ① until it makes a click (**click**). Ensure that the two arrows ④ face each other.
3. Put the cover ④ on the trimmer head ② while you feed the cutting filament ⑤ through the opening in the cover ④.
4. Put the cover ④ on the trimmer head ② until it makes a click (**click**). Make sure that all cams lock in position.

3. OPERATION



DANGER! Risk of injury!

Cut injury when the product starts accidentally.

→ Before you connect, adjust or transport the product, disconnect the mains cable and transport the product by the bottom handle.

To connect the trimmer [Fig. O1]:



DANGER! Electric shock!

To avoid damage to the mains cable ⑧ the extension cable ⑥ must be inserted into the cable lock ⑦.

→ Before you operate the product insert the extension cable ⑥ into the cable lock ⑦.

1. Loop the extension cable ⑥, insert the loop into the cable lock ⑦ and pull tight.
2. Connect the plug ⑧ of the product into the socket ⑨ of the extension cable ⑥.
3. Connect the extension cable ⑥ into a 230 V mains socket.

Work position [Fig. O2]:

→ Hold the product by the top part of the handle ① and the bottom handle ③ so that the trimmer head ② is tilted a small distance forward.

Make sure, the filament does not touch hard objects such as walls, stones and fences to prevent the filament from welding together or breaking.

To start the trimmer [Fig. O3]:



DANGER! Risk of injury!

Risk of injury if the product does not stop when you release the start button.

→ Do not bypass the safety devices or switches. For example do not attach the start button ⑩ to the handle.

To start:

→ Push the start button ⑩ on the top part of the handle ①.

To stop:

→ Release the start button ⑩.

To extend the cutting filament (Tip mechanism) [Fig. O4/O5]:

The tip mechanism operates **when the motor operates**. The best result occurs only with the maximum cutting filament length. During first operation, it can be necessary to extend the cutting filament many times.

1. Start the product.
2. Hold the trimmer head ② parallel to the ground and briefly tap the trimmer head ② onto a solid surface (prevent constant pressure for extended periods).

The cutting filament ⑤ is automatically extended with a mechanism that can be heard and adjusted to the correct length with the filament limiter ⑪. If necessary tap many times again and again.

4. MAINTENANCE



DANGER! Risk of injury!

Cut injury when the product starts accidentally.

→ Before you maintain the product, make sure that the mains cable is disconnected.

To clean the trimmer [Fig. M1]:



DANGER! Electric shock!

Risk of injury and risk of damage to the product.

→ Do not clean the product with water or with a water jet (in particular high-pressure water jet).

The airflow slots must always be clean.

1. Clean the airflow slots ⑫ with a soft brush (do not use a screwdriver).
2. Clean all movable parts after each operation. Especially remove any grass and dirt from the cover ④.

To replace the filament cassette [Fig. M2/M3]:



DANGER! Risk of injury!

Risk of injury from metal cutting parts!

→ Do not use metal cutting parts or replacement parts and accessories not approved by GARDENA.

Only use original GARDENA Filament Cassettes. You can order Replacement Filament Cassettes from your GARDENA dealer or directly from the GARDENA Customer Service. For Art. 9805 SmallCut 300/Art. 9806 SmallCut Plus 350: GARDENA Filament Cassette for Turbotrimmers Art. 5307.

1. Push in cassette cover ⑬ on the two locking clips ⑭ at the same time and remove.
2. Remove the filament cassette ⑮.
3. Remove all dirt.
4. Pull approximately 15 cm of the cutting filament ⑤ out of the new filament cassette ⑮ through the hole in the plastic ring ⑯.
5. First put the cutting filament ⑤ through the metal sleeve ⑰.
6. Put the cutting filament ⑤ around the guide pin ⑱.
7. Put the filament cassette ⑮ into the filament cassette holder ⑲.
8. Attach the cassette cover ⑬ on the filament cassette holder ⑲ until you hear both locking clips ⑭ make a click.

When attaching the cassette cover ⑬, the cutting filament ⑤ must be put around the guide pin ⑱ and must not be caught.

→ If the cassette cover ⑬ cannot be fully installed, turn the filament cassette ⑮ back and forth, until the filament cassette ⑮ is fully in the filament cassette holder ⑲.

5. STORAGE

To put into storage:

The product must be stored away from children.

1. Disconnect the mains cable.
2. Clean the product (see 4. MAINTENANCE).
3. Stow the product in a dry area where it has protection from frost.

Recommendation:

The product can be hung up by the handle. The cutting head is not put under too much strain if the product is stowed hanging up.

Disposal:

(in accordance with RL2012/19/EC/S.I. 2013 No. 3113)



The product must not be disposed of to normal household waste. It must be disposed of in line with local environmental regulations.

IMPORTANT!

→ Dispose of the product through or via your municipal recycling collection centre.

6. TROUBLESHOOTING



DANGER! Risk of injury!

Cut injury when the product starts accidentally.

→ Before you troubleshoot the product, make sure that the mains cable is disconnected.

To pull the cutting filament out of the filament cassette [Fig. T1/T2]:

If a cutting filament is pulled into the filament cassette you can pull it out again with the instructions below.

1. Remove the filament cassette ⑩ with the instructions under 4. MAINTENANCE "To replace the filament cassette".
2. Push together the plastic ring ⑩ on the filament cassette ⑩ between your thumb and index finger.
3. Pull the plastic ring ⑩ over the side part of the filament cassette (if necessary, use a screwdriver).
4. You can at this time get the cutting filament that was pulled into the filament cassette.
5. Unwind the cutting filament ⑤ by approx. 15 cm and put it through the eye of the plastic ring ⑩ (if necessary, loosen the welded cutting filament beforehand using a screwdriver, and unwind and wind fully).
6. Pull the plastic ring ⑩ onto the filament cassette ⑩.
7. Install the filament cassette ⑩ with the instructions under 4. MAINTENANCE "To replace the filament cassette".

| Problem | Possible Cause | Remedy |
|--|---|--|
| Product no longer cuts | Cutting filament worn or too short. | → Extend the cutting filament (see 3. OPERATION "To extend the cutting filament (Tip mechanism)"). |
| | Filament cassette empty. | → Replace the filament cassette (see 4. MAINTENANCE "To replace the filament cassette"). |
| | Cutting filament pulled into the cassette or stuck together. | → Pull the cutting filament out of the filament cassette (see above). |
| Cutting filament cannot be extended or cutting filament is used quickly | The cutting filament became too dry and brittle (e.g. during the winter). | → Place the filament cassette in water for approx. 10 hours. |
| | The cutting filament frequently touched hard objects. | → Prevent the cutting filament from touching hard objects. |



NOTE: For any other malfunctions please contact the GARDENA service department. Repairs must only be done by GARDENA service departments or specialist dealers approved by GARDENA.

7. TECHNICAL DATA

| Turbotrimmer | Unit | SmallCut 300 (Art. 9805) | SmallCut Plus 350 (Art. 9806) |
|---|------------------|--------------------------|-------------------------------|
| Motor power consumption | W | 300 | 350 |
| Mains voltage/ Mains frequency | V / Hz | 230 / 5 | 230 / 50 |
| Cutting filament thickness | mm | 1.6 | 1.6 |
| Cutting width | mm | 230 | 230 |
| Cutting filament supply | m | 6 | 6 |
| Cutting filament feed | | Tip mechanism | Tip mechanism |
| Rpm of filament cassette | rpm | 13,000 | 13,000 |
| Weight | kg | 1.6 | 1.8 |
| Sound pressure level L_{pA}¹⁾ Uncertainty k_{pA} | dB (A) | 83 3 | 83 3 |
| Sound power level L_{WA}²⁾ measured/guaranteed Uncertainty k_{WA} | dB (A) | 92/94 2.04 | 92/94 2.32 |
| Hand/arm vibration a_{vhw}¹⁾ Uncertainty k_a | m/s ² | 4.3 2.2 | 4.3 2.2 |

Measuring process complying with: ¹⁾ EN 50636-2-91 ²⁾ RL 2000/14/EG/S.I. 2001 No. 1701



NOTE: The stated vibration emission value has been measured according to a standardized test procedure and can be used for comparison of one electric power tool with another. It can also be used for preliminary evaluation of exposure. The vibration emission value can vary during actual use of the electric power tool.

8. ACCESSORIES

GARDENA Filament Cassette for Turbotrimmers

Art. 5307

9. SERVICE/WARRANTY

Service:

Please contact the address on the back page.

Warranty statement:

In the event of a warranty claim, no charge is levied to you for the services provided.

GARDENA Manufacturing GmbH grants a warranty for all original GARDENA new products for two years from the date of original purchase from the retailer, provided that the devices have been for private use only. This manufacturer's warranty does not apply to products acquired second hand. This warranty includes all significant defects of the product that can be proved to be material or manufacturing faults. This warranty is fulfilled by supplying a fully functional replacement product or by repairing the faulty product sent to us free of charge; we reserve the right to choose between these options. This service is subject to the following provisions:

- The product has been used for its intended purpose as per the recommendations in the operating instructions.
- Neither the purchaser nor a third party has attempted to open or repair the product.
- Only Original GARDENA replacement parts and wear parts have been used for operation.
- Presentation of the receipt.

Normal wear and tear of parts and components (such as blades, blade fixing parts, turbines, light bulbs, V-belts/toothed belts, impellers, air filters, spark plugs), visual changes, wear parts and consumables are excluded from the warranty.

This manufacturer's warranty is limited to replacement and repair of products in accordance with the abovementioned conditions. The manufacturer's warranty does not constitute an entitlement to lodge other claims against us as a manufacturer, such as for damages. This manufacturer's warranty does **not**, of course, affect statutory and contractual warranty claims against the dealer/retailer.

The manufacturer's warranty is governed by the law of the Federal Republic of Germany.

In case of a warranty claim, please return the faulty product, together with a copy of the receipt and a description of the fault, with postage paid to the service address.

Consumables:

The filament cassette and cassette cover are consumables and are not included in the guarantee.

| | |
|--|---|
| <p>DE EU-Konformitätserklärung Der Unterzeichnete bestätigt als Bevollmächtigte des Herstellers, der GARDENA Germany AB, PO Box 7454, S-103 92, Stockholm, Schweden, dass das (die) nachfolgend bezeichnete(n) Geräte(e) in der von uns in Verkehr gebrachten Ausführung die Anforderungen der harmonisierten EU-Richtlinien, EU-Sicherheitsstandards und produktspezifischen Standards erfüllen/erfüllen. Bei einer nicht mit uns abgestimmten Änderung des (der) Geräte(s) verliert diese Erklärung ihre Gültigkeit.</p> | <p>HU EU megfeleléségi nyilatkozat Az alulírott, a GARDENA Germany AB, Pf. 7454, S-103 92, Stockholm, Svédország megbízotti minőségében megerősíti, hogy az általunk alábbi kivitelben forgalomba hozott, lent nevezett eszköz(ök) megfelel(nek) az unióis irányelvekkel és szabványokkal meghatározott elvárások követelményeinek, az EU biztonsági szabványainak és a konkrét termékre vonatkozó szabványoknak. Az eszköz(ök)nek velünk megegyeztetett módosítása esetén ez a nyilatkozat érvényét veszti.</p> |
| <p>EN EC Declaration of Conformity The undersigned hereby certifies as the authorized representative of the manufacturer, GARDENA Germany AB, PO Box 7454, S-103 92, Stockholm, Sweden, that when leaving our factory, the unit(s) indicated below is/are in accordance with the harmonised EU guidelines, EU standards of safety and product specific standards. This certificate becomes void if the unit(s) is/are modified without our approval.</p> | <p>CS EU prohlášení o shodě Podpisem osoba zplnomocnená výrobcem GARDENA Germany AB, PO Box 7454, S-103 92, Stockholm, Švédsko potvrzuje, že v následujícím uvedený(-é) přístroj(-e) v provedení námi uvedeném na trh splňuje/splňují požadavky směrnice EU, bezpečnostních norem EU a norem specifických pro výrobek. V případě změny přístroje(-ů), která s námi nebyla dohodnuta, ztrácí toto prohlášení svou platnost.</p> |
| <p>FR Déclaration de conformité CE Le soussigné déclare, en tant que mandataire du fabricant, la GARDENA Germany AB, PO Box 7454, S-103 92, Stockholm, Suède, que het/ de onderstaand vermelde apparaat/apparaten in de door ons in de handel gebrachte uitvoering voldoet/voldoen aan de eisen van de geharmoniseerde EU-richtlijnen, EU-veiligheidsnormen en productspecifieke normen. Bij een niet met ons afgestemde verandering van het apparaat/de apparaten verliest deze verklaring haar geldigheid.</p> | <p>SK EÚ vyhlásenie o zhode Dolný podpísaný potvrdzuje, ako zplnomocnený zástupca výrobcu, GARDENA Germany AB, PO Box 7454, S-103 92, Stockholm, Švédsko, že ďalej označené zariadenie /a vo vyhotovení uvedenom na trh spĺňa/jú požiadavky harmonizovaných smerníc EU, bezpečnostných štandardov EÚ a predpisov, špecifických pre dané výrobky. Pri zmene zariadenia/zariadení, ktorá nebola odsúhlasená našou spoločnosťou, stráca toto vyhlásenie platnosť.</p> |
| <p>NL EU-conformiteitsverklaring De ondergetekende bevestigt als gevolmachtigde van de fabrikant, GARDENA Germany AB, PO Box 7454, S-103 92, Stockholm, Zweden, dat het/ de onderstaand vermelde apparaat/apparaten in de door ons in de handel gebrachte uitvoering voldoet/voldoen aan de eisen van de geharmoniseerde EU-richtlijnen, EU-veiligheidsnormen en productspecifieke normen. Bij een niet met ons afgestemde verandering van het apparaat/de apparaten verliest deze verklaring haar geldigheid.</p> | <p>EL Δήλωση συμμόρφωσης ΕΕ Ο υπογεγραμμένος βεβαιώνει ως πληρεξούσιος του κατασκευαστή, της εταιρείας GARDENA Germany AB, T.Θ. 7454, S-103 92, Στοκχόλμη, Σουηδία, ότι η (οι) παρακάτω αναφερόμενη(ες) συσκευή(ές) στην έκδοσή που τίθεται από εμάς σε κυκλοφορία πληροί/πληρούν τις απαιτήσεις των ευρωπαϊκών οδηγιών της ΕΕ, προτύπων ασφαλείας της ΕΕ και των ειδικών για το προϊόν προτύπων. Σε περίπτωση τροποποίησης της (των) συσκευή(ών) χωρίς προηγουμένη συναίνεσή μας παύει να ισχύει η δήλωση.</p> |
| <p>SV EU-försäkran om överensstämmelse Undertecknad intygar som befulldäktad företrädare för tillverkaren, GARDENA Germany AB, PO Box 7454, S-103 92, Stockholm, Sverige, att nedan angiven apparat/ nedan angivna apparater i det utförande vi har släppt på marknaden, uppfyller fordringarna i de harmoniserade EU-direktiv, EU-säkerhetsstandarderna och de produktspecifika standarderna. Denna försäkran upphör att gälla vid en ändring av apparaten/apparaterna som inte har ståmits av med oss.</p> | <p>SL Izjava EU o skladnosti Spodaj podpisani kot pooblaščenec proizvajalca GARDENA Germany AB, PO Box 7454, S-103 92, Stockholm, Švedska, potrjuje, da v nadaljevanju označene naprave v izvedbi, v kakršni smo jih dali v promet, izpolnjuje zahteve usklajenih direktiv EU, varnostnega standarda EU in standardov, ki veljajo za posamezne izdelke. V primeru spremembe naprave, ki ni usklajena z nami, ta izjava neha veljati.</p> |
| <p>DA EU-overensstemmelseserklæring Underskriveren bekræfter som fuldmægtig for producenten, GARDENA Germany AB, PO Box 7454, S-103 92, Stockholm, Sverige, at det (de) efterfølgende betegnede apparat(er) i den af os markerede udførelse opfylder kravene i de harmoniserede EU-direktiv, EU-sikkerhedsstandarder og produktspecifikke standarder. Føretaget en ændring af apparatet/apparaterne, der ikke er aftalt med os, mister denne erklæring sin gyldighed.</p> | <p>HR EU izjava o sukladnosti Dolje potpisani kao opruomocnik proizvođača, tvrtke GARDENA Germany AB, PO Box 7454, S-103 92, Stockholm, Švedska, potvrđujem da niže navedeni uređaj(i) odgovarajuće izvedbe koji/koje smo iznijeli na tržište ispunjavaju kriterije usklađenih direktiva EU i sigurnosnih standarda EU kao i standarda koji se tiču proizvođača. Ova izjava gubi valjanost u slučaju izmjena uređaja koje nisu prethodno ugovorene s nama.</p> |
| <p>FI EU-vaatimustenmukaisuusvakuutus Allekirjoittanut vahvistaa valmistajan, GARDENA Germany AB, PO Box 7454, S-103 92, Tukholma, Ruotsi, valtuuttamansa henkilöä, että seuraava laite täyttää/ seuraavat laitteet täyttävät meidän toimittamassa mallissa yhdenmukaistettujen EU-direktiivien, EU-turvallisuusnäyttöjen ja tuotekohkeisten standardien vaatimukset. Laitteen/ laitteiden muutoksissa, joista ei ole sovittu meidän kanssamme, menettää tämä selvitys voimassolonsa.</p> | <p>RO Declarație de conformitate UE Semnatarul, în calitate de reprezentant al producătorului GARDENA Germany AB, PO Box 7454, S-103 92, Stockholm, Suedia, confirmă că aparatul (aparatele) descrise în cele ce urmează, în execuția pusă de noi pe piață îndeplinesc cerințele directivei armonizate UE, ale standardelor de siguranță UE și ale standardelor specifice produsului. În cazul modificării fără aprobarea noastră prealabilă a aparatului (aparateror), această declarație își pierde valabilitatea.</p> |
| <p>IT Dichiarazione di conformità UE Il sottoscritto, in quanto soggetto autorizzato dal produttore, GARDENA Germany AB, PO Box 7454, S-103 92, Stoccolma, Svezia, dichiara che l'apparecchio/gli apparecchi di seguito denominato/i, nella versione da noi immessa in commercio, soddisfa/ no i requisiti delle direttive UE armonizzate, degli standard di sicurezza europei e degli standard specifici per il prodotto. La presente dichiarazione perde di validità in caso di modifica dell'apparecchio/ degli apparecchi non concordata con noi.</p> | <p>BG ЕС-Декларация за съответствие Долноподписанят удостоверява като пълномощник на производителя GARDENA Germany AB, PO Box 7454, S-103 92, Стокхолм, Швеция, че по-долу описаните(ите) уреди(и) във вариант на изпълнение пунат от нас на пазара изпълнява/ изпълняват изискванията на хармонизираните ЕС-директиви, ЕС-норми за безопасност и специфичните норми за продукцията. В случай на промяна на уреда(ите), която не е съгласувана с нас, тази декларация губи своята валидност.</p> |
| <p>ES Declaración de conformidad de la UE El firmante confirma, en calidad de operado del fabricante GARDENA Germany AB, PO Box 7454, S-103 92 Estocolmo (Suecia), que el/ los aparato(s) mencionado(s) a continuación cumple(n), en la versión lanzada al mercado por nuestra empresa, los requisitos de las directivas de la UE armonizadas, los estándares de seguridad de la UE y los estándares específicos del producto. La presente declaración perderá su validez si se modifica(n) el/ los aparato(s) sin previa aprobación por nuestra parte.</p> | <p>ET EL-i vastavuseklaratsioon Alakirjutajana kinnitab tootja, GARDENA Germany AB, PO Box 7454, S-103 92, Stockholm, Rootsi, poolt volitatud isikuna, et järgnevalt nimetatud seade (seadmed) täidab (täidavad) meil poolt turule toodud versiooni kuulj harmoniseeritud EL-i direktiivide, EL-i ohutusstandardite ja tootepühiste standardite nõudeid. Seadme (seadmete) meiega kooskõlastamata muudatuste tegemise korral kaotab käesolev deklaratsioon oma kehtivuse.</p> |
| <p>PT Declaração CE de Conformidade O abaixo-assinado, na qualidade de representante do fabricante, GARDENA Germany AB, PO Box 7454, S-103 92, Stockholm, Schweden, confirma que o(s) aparelho(s) a seguir designado(s) no modelo lançado por nós no mercado cumpre/ cumprem os requisitos das diretivas UE harmonizadas, as normas de segurança UE e as normas específicas para estes produtos. Esta declaração perde a sua validade se forem realizadas alterações no(s) aparelho(s) sem o nosso consentimento.</p> | <p>LT ES atitikties deklaracija Pasirašantis, kaip gamintojo, GARDENA Germany AB, PO Box 7454, S-103 92, Stokholmas, Švedija, įgaliotasis atstovas patvirtina, kad žemiau nurodyti(-ų) prietaisai(-ų) modeliai, kurie buvo pagaminti mūsų gamyklose, atitinka darnijas ES direktyvas, ES saugumo standartus ir specifinius gaminių standartus. Atlikus bet kokį prietais(-ų) pakeitimą, kuris nėra suderintas su mumis, ši deklaracija praranda galiojimą.</p> |
| <p>PL Deklaracja zgodności UE Nижє podpisany potwierdza jako upoważniony przedstawiciel producenta, spółki GARDENA Germany AB, PO Box 7454, S-103 92, Stokholm, Szwecja, że określone poniżej urządzenie/-nia w wersji wprowadzonej przez nas do obrotu spełnia/ -niają wymogi zharmonizowanych dyrektyw UE, norm bezpieczeństwa UE oraz norm dotyczących konkretnych produktów. Niniejsza deklaracja traci ważność w przypadku wprowadzania niezgodnych z nami zmian urządzenia/-ń.</p> | <p>LV ES atbilstības deklarācija Lēmē parakstījis šīs personas kā ražotāja, GARDENA Germany AB, PO Box 7454, S-103 92, Stokholma, Zviedrija, pilnvarotais pārstāvis apstiprina, ka tālāk norādītā(-s) ierīce(-s) izpildījuma, kādā mēs to (tās) esam laiduši tirgū, atbilst saskaņotajam ES direktīvam, ES drošības standartiem un konkrētajām produktām noteiktajiem standartiem. Ierīce(-s) veicot ar mums nesaskaņotus izmaiņus, šī deklarācija zaudē savu spēku.</p> |

| | | | | | |
|--|---|--|---|--|---|
| <p>Produktbezeichnung: Description of the product: Désignation du produit : Beschrijving van het product: Beskrivning av produkt: Beskrivelse af produktet: Tuotteen kuvaus: Descrizione del prodotto: Descripción del producto: Descrição do produto: Opis produktu: A termék leírása: Popis výrobku: Popis produktu: Περιγραφή του προϊόντος: Opis izdelka: Opis proizvoda: Descrierea produsului: Описание продукта: Toote kirjeldus: Gaminio aprašas: Izstrādājuma apraksts:</p> | <p>Turbotrimmer Turbotrimmer Coupe-bordures Turbotrimmer Turbotrimmer Turbotrimmer Turbotrimmer Turbotrimmer Recortabordes Aparador de relva Turbotrimmer Podkaszarka Damilos fűszéglynyíró Turbotrimmer Turbotrimmer Κοιμητικό πετονιάς Turbo obrezovalnik Turbo trimer za travu Turbotrimmer Турбогримпер Turbotrimmer Turbo žolijapjovė Turbotrimmeris</p> | <p>Termetíktípus: Druh výrobku: Type de produit: Producttype: Producttype: Producttype: Tip produs: Тип продукта: Tipo de producto: Tipo de produto: Typ produktu:</p> | <p>Artikelnúmer: Article number: Réfèrençè : Artikelnúmer: Artikelnúmer: Tiputenumero: Codice articolo: Referençia: Número de referençia: Numer katalogowy: Cikkszámok: Objednací číslo: Objednávacie číslo: Κωδικός είδους: Ştevilka izdelka: Katalóski broj: Cod articol: Artikulu numer: Artikelnúmer: Daliess numeris: Artikula numurs:</p> | <p>SmallCut 300 SmallCut Plus 350</p> <p>EU-Richtlijnen: EC-Directives: Directives CE : EG-richtlijnen: EU-direktiv: EU-direktiver: EY-direktiv: Directive UE: Directiva CE: Dretivas CE: Direktywy WE: EK-irányelvek: Predpisy ES: Smernice EU: Önyvics EK: Direktive EU: EC direktive: Directive CE: Директиви на ЕО: EU direktiv: 2006/42/EC 2014/30/EU 2000/14/EC 2011/65/EU</p> | <p>Harmoniserte EN-Normen / Harmonised EN: EN 60335-1 EN 50636-2-91 EN ISO 12100</p> <p>Schall-/Leistungspegel: Noise level: Niveau sonore : Geluidsniveaue: Ljudnívää: Stójniveaue: Äänitaso: Livello acustico: Nivel de ruido: Nivel de ruido: Poziom halasu: Zajszint: Hladina hluku: Hladiny hluku: gemessen/ garantiert measured/ guaranteee mesuré/ garanti gemeten/ gegarandeerd uppmätt/ garantatad målt/ garantatet mitattu/ taattu misurato/ garantito medido/ garantizado medido/ garantido zmierzony/ gwarantowany mért/ garantált naměřená/ zaručenää nameraná/ zaručenää</p> <p>Anbringungsjahr der CE-Kennzeichnung: Year of CE marking: Année d'apposition du marquage CE : Installatiejaar van de CE-aanduiding: Märkningsår: CE-Märkningsår: CE-merkkin kiinnitysvuosi: Anno di applicazione della certificazione CE: Colocación del distintivo CE: Ano de marcaçáo pela CE: Rok nadania oznakowania CE: CE-jelzés elhelyezésének éve: Epíneuo ðorúbou: Raven zvóčne moçi: Razina buke: Nivel de zgomot: Ниво на шум: Múratase: Triukšmo lygis : Trokšna límenis : 9805 9806</p> <p>Rok umístění značky CE: Rok udelenia značky CE: Ετος σήματος CE: Leto namestitve CE-oznake: Godina dobivanja CE oznake: Anul de marcare CE: Godina na postavljanje na CE-маркировка: CE-márgistuse paigaldamise aasta: Metai, kada pažymeta CE-ženklui: CE-markejuma uzlikšanas gads: 2015</p> <p>Ulme, den 30.09.2021 Ulme, 30.09.2021 Fait à Ulme, le 30.09.2021 Ulme, 30-09-2021 Ulme, 2021.09.30. Ulme, 30.09.2021 Ulmissa, 30.09.2021 Ulme, 30.09.2021 Ulme, 30.09.2021 Ulme, 30.09.2021 Ulme, 30.09.2021 Ulme, 30.09.2021 Ulme, 30.09.2021 Ulme, 30.09.2021 Ulme, 30.09.2021 Ulme, 30.09.2021 Ulme, 30.09.2021 Ulme, 30.09.2021 Ulme, 30.09.2021 Ulme, 30.09.2021 Ulme, 30.09.2021 Ulme, 30.09.2021 Ulme, 30.09.2021 Ulme, 30.09.2021 Ulme, 30.09.2021</p> <p>Der Bevollmächtigte Authorised representative Le mandataire De gevolmachtigde Auktoriserad representant Autoriseret repræsentant Valtuutettu edustaja Persona delegata La persona autorizada O reprezentante Pārtomocnik Meghatalmazott Zplnomocnenec Spilnomocneny O εξουσιοδοτημένος Pooblaščenec Ovlaštena osoba Conducerea tehnicää Упълномощен Volitatud esindaja İgaliotasis atstovas Pilnvarotā persona</p> <p>Reinhard Pompe Vice President</p> <p>Wolfgang Engelhardt Vice President Supply Chain</p> |
|--|---|--|---|--|---|

EN UKCA Declaration of Conformity (only for UK)

The manufacturer: GARDENA Germany AB, PO Box 7454, S-103 92 Stockholm, Sweden hereby certifies, when leaving our factory, the unit(s) indicated below is/are in accordance with the UK Regulations, designated standards of safety and product specific designated standards. This certificate becomes void if the units are modified without our approval.

Description of the Product: **Turbotrimmer**

Product type: **SmallCut Plus 350**

Article Number: **9806-28**

UK regulations: **S.I. 2008/1597
S.I. 2016/1091
S.I. 2012/3032
S.I. 2001/1701**

Designated Standards: **EN ISO 12100
EN 60335-1
EN 60335-2-77**

Authorised Representative: **Husqvarna UK Limited**

Deposited Documentation: **Preston Road,
Aycliffe,
County Durham
UK
DL5 6 UP**

Noise level: measured / guaranteed **Art. 9674825-xx: 92 dB(A) / 93 dB(A)
Art. 9674828-xx: 91 dB(A) / 91 dB(A)
Art. 9674829-xx: 92 dB(A) / 93 dB(A)**

Conformity Assessment according to: **According to S.I. 2001/1701 Art, 11 Schedule 9**

Aycliffe, 10.09.2021

Authorised Representative:



**John Thompson
Director**

| | | | | |
|---|--|--|--|--|
| <p>Deutschland / Germany GARDENA Manufacturing GmbH Central Service Hans-Lorenser-Straße 40 D-89079 Ulm Produktfragen: (+49) 731 490-123 Reparaturen: (+49) 731 490-290 service@gardena.com http://www.gardena.com</p> | <p>Costa Rica Exim CIA Costa Rica Calle 25A, B°. Montalegre Zapote San José Costa Rica Phone: (+506) 2221-5654 (+506) 2221-5659 eximcostanica@gmail.com</p> | <p>Ireland Liffey Distributors Ltd. 309 NW Business Park, Ballycoolan 15 Dublin Phone: (+353) 1 824 2600 info@liffeyd.com</p> | <p>Netherlands Husqvarna Nederland B.V. GARDENA Division Postbus 50131 1305 AC ALMERE Phone: (+31) 36 521 00 10 info@gardena.nl</p> | <p>South Africa Husqvarna South Africa (Pty) Ltd Lifestyle Business Park – Ground Floor Block A Cnr Beyers Naude Drive and Ysterhout Road Randpark Ridge, Randburg Phone: (+27) 10 015 5750 service@gardena.co.za</p> |
| <p>Albania KRAFT SHPK Autostrada Tirane-Durres Km 7 1051 Tirane Phone: (+355) 69 877 7821 info@kraft.al</p> | <p>Croatia Husqvarna Austria GmbH Industriježele 36 4010 Linz Phone: (+43) 732 77 01 01-485 service.gardena@husqvarnagroup.com</p> | <p>Israel HAGARIN LTD. 2 Nahal Harif St. 8122201 Yavne internet@hagarin.co.il Phone: (+972) 8-932-0400</p> | <p>Neth. Antilles Jonka Enterprises N.V. Sta. Rosa Weg 196 P.O. Box 8200 Curaçao Phone: (+599) 9 767 66 55 info@jonka.com</p> | <p>Spain Husqvarna España S.A. Calle de Rivas nº 10 28052 Madrid Phone: (+34) 91 708 05 00 atencioncliente@gardena.es</p> |
| <p>Argentina ROBERTO C. RUMBO S.R.L. Predio Norlog Lote 7 Benavidez, ZC: 1621 Buenos Aires ventas@rumbosrl.com.ar</p> | <p>Cyprus Pantelis Papadopoulos S.A. 92 Athinon Avenue Athens 10442 Greece Phone: (+30) 21 0519 3100 infocyp@papadopoulos.com.gr</p> | <p>Italy Husqvarna Italia S.p.A. Via Santa Vecchia 15 23868 VALMADRERA (LC) Phone: (+39) 0341.203.111 assistenza.italia@it.husqvarna.com</p> | <p>New Zealand Husqvarna New Zealand Ltd. PO Box 76-437 Manukau City 2241 Phone: (+64) (0) 9 9202410 support.nz@husqvarna.co.nz</p> | <p>Sri Lanka Hunter & Company Ltd. 130 Front Street Colombo Phone: 94-11 232 81 71 hurters@eureka.lk</p> |
| <p>Armenia AES Systems LLC Marshal Babajanyan Avenue 56/2 0022 Yerevan Phone: (+374) 60 651 651 masisohanyan@cloud.com</p> | <p>Czech Republic Gardena Service Center Vrbno c/o Husqvarna Manufacturing CZ s.r.o. Jesenická 146 79326 Vrbno pod Prádedem Phone: 800 100 425 servis@gardena.cz</p> | <p>Japan Husqvarna Zenoh Co. Ltd. Japan 1-9 Minamidai, Kawagoe 350-1165 Saitama Japan gardena-jp@husqvarnagroup.com</p> | <p>North Macedonia Sinpeks d.o.o. Ul. Kravarski Pat Bb 7000 Bitola Phone: (+389) 47 20 85 00 sinpeks@mt.net.mk</p> | <p>Suriname Deto Handelmaatschappij N.V. Kernkampweg 72-74 P.O. Box: 12782 Paramaribo Suriname Phone: (+597) 438050 info@deto.sr</p> |
| <p>Australia Husqvarna Australia Pty. Ltd. Locked Bag 5 Central Coast BC NSW 2252 Phone: (+61) (0) 2 4352 7400 customer.service@husqvarna.com.au</p> | <p>Denmark GARDENA DANMARK Lejvej 19, st. 3500 Værløse Tlf.: (+45) 70 26 47 70 husqvarna@husqvarna.dk www.gardena.com/dk</p> | <p>Kazakhstan TOO "Ламед" Russian Адрес: Қазақстан, г. Алматы, ул. Тажибаевой, 155/1 Тел.: (+7) (727) 355 64 00 (+7) (700) 355 64 00 lamed@lamed.kz</p> | <p>Norway Husqvarna Norge AS Gardena Division Treskenveien 36 1708 Sarpsborg info@gardena.no</p> | <p>Sweden Husqvarna AB / GARDENA Sverige Drottninggatan 2 561 82 Huskvarna Sverige Phone: (+46) (0) 36-14 60 02 info@gardena.se</p> |
| <p>Austria / Österreich Husqvarna Austria GmbH Industrielle 36 4010 Linz Tel.: (+43) 732 77 01 01-485 service.gardena@husqvarnagroup.com</p> | <p>Dominican Republic BOSQUESA, S.R.L. Carretera Santiago Licey Km. 5 ½ Esquina Copal II. Santiago De Los Caballeros 51000 Dominican Republic Phone: (+1) 809-562-0476 contacto@bosquesa.com.do</p> | <p>Korea Kyung Jin Trading Co., Ltd 107-4, Sunduk Bld, Yangjae-Dong Seocho-Gu 137-891 Seoul Phone: (+82) 2 574 6300 kjh@kjh.co.kr</p> | <p>Northern Cyprus Mediterranean Home & Garden No 150 Alsancak, Karaoglanoglu Caddesi Gine Phone: (+90) 392 821 33 80 info@medgardener.com</p> | <p>Switzerland / Schweiz Husqvarna Schweiz AG Consumer Products Industriestrasse 10 5506 Mägerlen Phone: (+41) (0) 62 887 37 90 info@gardena.ch</p> |
| <p>Azerbaijan Proqres Xüsusi Firması Aliyar Aliyev 212, Baku, Azerbaijan Sales: +994 70 328 07 14 Aftersales: +994 77 326 07 14 www.proqres-garden.az info@proqres-garden.az</p> | <p>Egypt Universal Agencies Co 26, Abdel Hamid Lotfy St. Giza Phone: 3761 5757 https://gardeningegypt.com/ hany.masoud@univag.org/</p> | <p>Kuwait Palms Agro Production Co Al Rai- Fourth Ring Road – Block 56. P.O Box: 1976 Safat 13020 Al-Rai Phone: 24730745 info@palms-kw.com</p> | <p>Peru Sierras y Herramientas Forestal SAC Av. Las Gaviotas 833, Chorrillos Lima Phone: (+51) 1 2520252 supervisorventas1@siersac.com www.siersac.com</p> | <p>Taiwan Hong Ying Trading Co., Ltd. No. 46 Wu-Kun-Wu Road New Taipei City Phone: (+886) (02) 2298 1486 salesg1@7friends.com.tw</p> |
| <p>Bahrain M.H. Al-Mahroos BUILDING 208, BLOCK 356, ROAD 328 Salhiya Phone: +973 1740 8090 almahroos@almahroos.com</p> | <p>France Husqvarna France 9/11 Allée des pierres mayettes 92635 Gennemilliers Cedex France http://www.gardena.com/fr N° AZUR: 0 810 00 78 23 (Prix d'un appel local)</p> | <p>Latvia Husqvarna Latvija SIA Ulbrokas 19A LV-1021 Riga info@gardena.lv</p> | <p>Philippines Royal Dragon Traders Inc 10 Linaw Street, Barangay Saint Peter Quezon City 1114 Philippines Phone: (+63) 2 7426893 aida.fernandez@rdti.com.ph</p> | <p>Thailand Spica Co. Ltd 243/2 Onnuch Rd., Prawat Bangkok 10250 Thailand Phone: (+66) (0)2721 7373 surapong@spica-siam.com</p> |
| <p>Belarus / Беларусь ООО «Мастер Гарден» 220118, г. Минск, улица Шаранговича, дом 7а Тел. (+375) 17 257 00 33 mg@mastergarden.by</p> | <p>Georgia Transporter LLC #70, Belashvili street 0159 Tbilisi, Georgia Number: (+995) 322 14 71 71 info@transporter.com.ge www.transporter.com.ge</p> | <p>Malaysia Glomedic International Sdn Bhd Jalan Ruang No. 30 Shah Alam, Selangor 40150 Malaysia Phone: (03)-7734 7997 oase@glomedic.com.my</p> | <p>Poland Gardena Service Center Vrbno c/o Husqvarna Manufacturing CZ s.r.o. Jesenická 146 79326 Vrbno pod Prádedem Czech Republic Phone: (22) 336 78 90 servis@gardena.pl</p> | <p>Tajikistan ARIERS JV LLC 39, Ayni Street, 7734024 Dushanbe, Tajikistan</p> |
| <p>Belgium Husqvarna Belgium nv Gardena Division Leuvensesteenweg 542 Planet II E 1930 Zaventem België</p> | <p>Germany Husqvarna 9/11 Allée des pierres mayettes 92635 Gennemilliers Cedex France http://www.gardena.com/fr N° AZUR: 0 810 00 78 23 (Prix d'un appel local)</p> | <p>Malta I.V. Portelli & Sons Ltd. 85, 86, Triq San Pawl Rabat - RBT 1240 Phone: (+356) 2145 4289</p> | <p>Portugal Husqvarna Portugal, SA Lagoa - Albarraq 2635 - 595 Rio de Mouro Phone: (+351) 21 922 85 30 Fax: (+351) 21 922 85 36 info@gardena.pt</p> | <p>Turkey Dost Bahçe Yunus Mah. Adil Sk. No:3 Kartal Istanbul 34873 Turkey Phone: (+90) 216 389 39 39 info@dostbahce.com.tr www.dostbahce.com.tr</p> |
| <p>Bosnia / Hercegovina Silk Trade d.o.o. Poslovnna Zona Vila Br. 20 Phone: (+387) 61 165 593 info@silktade.com.ba</p> | <p>Hong Kong Tung Tai Company 151-153 Hoi Bun Road Kwun Tong, Kowloon Hong Kong Phone: (+852) 3583 1662 admin@tungtaico.com</p> | <p>Mexico AFOSA Av. Lopez Mateos Sur # 5019 Col. La Calma 45070 Zapopan, Jalisco, Mexico Phone: (+52) 33 3818-3434 isolis@afosa.com.mx</p> | <p>Romania Madex International Srl Soseaua Odaii 117 - 123, RO 013603 Bucuresti, S1 Phone: (+40) 21 352 7603 madex@ines.ro</p> | <p>Turkmenistan I.E. Orazmuhammedov Nurmuhammet 80 Ataturk, BERKARAR Shopping Center, Ground floor, A770, ASHGABAT 744000, TURKMENISTAN Phone: (+993) 12 468859 Mob: (+993) 62 222887 info@jayhyzmat.com / bekgiyev@jayhyzmat.com www.jayhyzmat.com</p> |
| <p>Brazil Nordtech Maquinas e Motores Ltd. Avenida Juscelino Kubitschek de Oliveira Curitiba 3003 Brazil Phone: (+55) 41 3595-9600 contato@nordtech.com.br www.nordtech.com.br</p> | <p>Hungary Husqvarna Magyarorszáგ Kft. Ezred u. 1 – 3 1044 Budapest Phone: (+36) 1 251-4161 vezesvolgalat.husqvarna@husqvarna.hu</p> | <p>Moldova Convel SRL Republica Moldova, mun. Chisinau, sos. Muncetii 284 Phone: (+373) 22 857 126 www.convel.md</p> | <p>Russia / Россия "Хускварна" 141400, Московская обл., г. Химки, улица Ленинградская, владение 39, стр.6 Бизнес Центр „Химки Бизнес Парк“, помещение OB02_04 http://www.gardena.ru</p> | <p>UAE Al-Futtaim ACE Company L.L.C Building, Al Rebat Street Festival City, Dubai 7880 UAE Phone: (+971) 4 206 6700 ace@alfuttaim.ae</p> |
| <p>Bulgaria AGROLAND България АД бул. 8 Декември, № 13 Офис 5 1700 Студентски град София Тел.: (+359) 24 66 6910 info@agroland.eu</p> | <p>India B K RAMAN AND CO Plot No. 185, Industrial Area, Phase-2, Ram Darbar Chandigarh 160002 India Phone: (+91) 98140 06530 raman@jagannhardware.com</p> | <p>Mongolia Soyolj Gardening Shop Namiid Rd Ulaanbaatar 14230 Mongolia Phone: +976 7777 5080 soyolj@maginet.mn</p> | <p>Saudi Arabia SACO Takhassusi Main Road P.O. Box: 86387 Riyadh 12863 40011 Saudi Arabia Phone: (966) 11 482 8877 webmaster@saco-ksa.com</p> | <p>Uruguay FELI SA Entre Rios 1083 11800 Montevideo Phone: (+598) 2203 1844 info@felisa.com.uy</p> |
| <p>Canada / USA GARDENA Canada Ltd. 100 Summerlea Road Brampton, Ontario L6T 4X3 Phone: (+1) 905 792 93 30 info@gardenacanada.com</p> | <p>Iceland BYKO ehf. Skemmuvegji 2a 200 Kópavogur Phone: (+354) 515 4000 byko@byko.is</p> | <p>Morocco Proekip 64 Rue de la Participation Casablanca-Boches Noires 20303 Morocco Phone: (+212) 661342107 hicham.hafani@proekip.ma</p> | <p>Singapore Hy-Ray PRIVATE LIMITED 40 Jalan Pemimpin #02-08 Tat Ann Building Singapore 577185 Phone: (+65) 6253 2277 info@hyray.com.sg</p> | <p>Ukraine / Україна AT «Альцест» вул Петропавлівська 4 08130, Київська обл. Києво-Святошинський р-н, с. Петропавлівська Борщагівка Україна Тел.: (+38) 0 800 503 000</p> |
| <p>China Husqvarna (Shanghai) Management Co., Ltd. 高世华 (上海) 管理有限公司 Jifeng Square B, No207, Song Hong Rd., Chang Ning District, Shanghai, PRC. 200335 上海市长宁区淞虹路207号明 泰广场B座307楼, 邮编: 200335</p> | <p>Colombia Equipos de Toyama Colombia SAS Cra. 68 D № 25 B 86 Of. 618 Edificio Torre Central Bogota Phone: +57 (1) 703 9520 +57 (1) 703 9522 serviciocliente@toyama.com.co www.toyama.com.co</p> | <p>Nepal Husqvarna Nepal Pvt. Ltd. Kathmandu Phone: (+977) 1 422 2222</p> | <p>Slovak Republic Gardena Service Center Vrbno c/o Husqvarna Manufacturing CZ s.r.o. Jesenická 146 79326 Vrbno pod Prádedem Phone: 0800 154044 servis@gardena.sk</p> | <p>Zimbabwe Cutting Edge 159 Citroen Rd, Msasa Harare Phone: (+263) 8677 008685 sales@cuttingedge.co.zw</p> |
| <p>Costa Rica Exim CIA Costa Rica Calle 25A, B°. Montalegre Zapote San José Costa Rica Phone: (+506) 2221-5654 (+506) 2221-5659 eximcostanica@gmail.com</p> | <p>Croatia Husqvarna Austria GmbH Industriježele 36 4010 Linz Phone: (+43) 732 77 01 01-485 service.gardena@husqvarnagroup.com</p> | <p>Israel HAGARIN LTD. 2 Nahal Harif St. 8122201 Yavne internet@hagarin.co.il Phone: (+972) 8-932-0400</p> | <p>Neth. Antilles Jonka Enterprises N.V. Sta. Rosa Weg 196 P.O. Box 8200 Curaçao Phone: (+599) 9 767 66 55 info@jonka.com</p> | <p>Spain Husqvarna España S.A. Calle de Rivas nº 10 28052 Madrid Phone: (+34) 91 708 05 00 atencioncliente@gardena.es</p> |
| <p>Argentina ROBERTO C. RUMBO S.R.L. Predio Norlog Lote 7 Benavidez, ZC: 1621 Buenos Aires ventas@rumbosrl.com.ar</p> | <p>Cyprus Pantelis Papadopoulos S.A. 92 Athinon Avenue Athens 10442 Greece Phone: (+30) 21 0519 3100 infocyp@papadopoulos.com.gr</p> | <p>Italy Husqvarna Italia S.p.A. Via Santa Vecchia 15 23868 VALMADRERA (LC) Phone: (+39) 0341.203.111 assistenza.italia@it.husqvarna.com</p> | <p>New Zealand Husqvarna New Zealand Ltd. PO Box 76-437 Manukau City 2241 Phone: (+64) (0) 9 9202410 support.nz@husqvarna.co.nz</p> | <p>Sri Lanka Hunter & Company Ltd. 130 Front Street Colombo Phone: 94-11 232 81 71 hurters@eureka.lk</p> |
| <p>Armenia AES Systems LLC Marshal Babajanyan Avenue 56/2 0022 Yerevan Phone: (+374) 60 651 651 masisohanyan@cloud.com</p> | <p>Denmark GARDENA DANMARK Lejvej 19, st. 3500 Værløse Tlf.: (+45) 70 26 47 70 husqvarna@husqvarna.dk www.gardena.com/dk</p> | <p>Kazakhstan TOO "Ламед" Russian Адрес: Қазақстан, г. Алматы, ул. Тажибаевой, 155/1 Тел.: (+7) (727) 355 64 00 (+7) (700) 355 64 00 lamed@lamed.kz</p> | <p>Norway Husqvarna Norge AS Gardena Division Treskenveien 36 1708 Sarpsborg info@gardena.no</p> | <p>Sweden Husqvarna AB / GARDENA Sverige Drottninggatan 2 561 82 Huskvarna Sverige Phone: (+46) (0) 36-14 60 02 info@gardena.se</p> |
| <p>Australia Husqvarna Australia Pty. Ltd. Locked Bag 5 Central Coast BC NSW 2252 Phone: (+61) (0) 2 4352 7400 customer.service@husqvarna.com.au</p> | <p>Dominican Republic BOSQUESA, S.R.L. Carretera Santiago Licey Km. 5 ½ Esquina Copal II. Santiago De Los Caballeros 51000 Dominican Republic Phone: (+1) 809-562-0476 contacto@bosquesa.com.do</p> | <p>Korea Kyung Jin Trading Co., Ltd 107-4, Sunduk Bld, Yangjae-Dong Seocho-Gu 137-891 Seoul Phone: (+82) 2 574 6300 kjh@kjh.co.kr</p> | <p>Northern Cyprus Mediterranean Home & Garden No 150 Alsancak, Karaoglanoglu Caddesi Gine Phone: (+90) 392 821 33 80 info@medgardener.com</p> | <p>Switzerland / Schweiz Husqvarna Schweiz AG Consumer Products Industriestrasse 10 5506 Mägerlen Phone: (+41) (0) 62 887 37 90 info@gardena.ch</p> |
| <p>Azerbaijan Proqres Xüsusi Firması Aliyar Aliyev 212, Baku, Azerbaijan Sales: +994 70 328 07 14 Aftersales: +994 77 326 07 14 www.proqres-garden.az info@proqres-garden.az</p> | <p>Egypt Universal Agencies Co 26, Abdel Hamid Lotfy St. Giza Phone: 3761 5757 https://gardeningegypt.com/ hany.masoud@univag.org/</p> | <p>Kuwait Palms Agro Production Co Al Rai- Fourth Ring Road – Block 56. P.O Box: 1976 Safat 13020 Al-Rai Phone: 24730745 info@palms-kw.com</p> | <p>Peru Sierras y Herramientas Forestal SAC Av. Las Gaviotas 833, Chorrillos Lima Phone: (+51) 1 2520252 supervisorventas1@siersac.com www.siersac.com</p> | <p>Taiwan Hong Ying Trading Co., Ltd. No. 46 Wu-Kun-Wu Road New Taipei City Phone: (+886) (02) 2298 1486 salesg1@7friends.com.tw</p> |
| <p>Bahrain M.H. Al-Mahroos BUILDING 208, BLOCK 356, ROAD 328 Salhiya Phone: +973 1740 8090 almahroos@almahroos.com</p> | <p>France Husqvarna France 9/11 Allée des pierres mayettes 92635 Gennemilliers Cedex France http://www.gardena.com/fr N° AZUR: 0 810 00 78 23 (Prix d'un appel local)</p> | <p>Latvia Husqvarna Latvija SIA Ulbrokas 19A LV-1021 Riga info@gardena.lv</p> | <p>Philippines Royal Dragon Traders Inc 10 Linaw Street, Barangay Saint Peter Quezon City 1114 Philippines Phone: (+63) 2 7426893 aida.fernandez@rdti.com.ph</p> | <p>Thailand Spica Co. Ltd 243/2 Onnuch Rd., Prawat Bangkok 10250 Thailand Phone: (+66) (0)2721 7373 surapong@spica-siam.com</p> |
| <p>Belarus / Беларусь ООО «Мастер Гарден» 220118, г. Минск, улица Шаранговича, дом 7а Тел. (+375) 17 257 00 33 mg@mastergarden.by</p> | <p>Georgia Transporter LLC #70, Belashvili street 0159 Tbilisi, Georgia Number: (+995) 322 14 71 71 info@transporter.com.ge www.transporter.com.ge</p> | <p>Malaysia Glomedic International Sdn Bhd Jalan Ruang No. 30 Shah Alam, Selangor 40150 Malaysia Phone: (03)-7734 7997 oase@glomedic.com.my</p> | <p>Poland Gardena Service Center Vrbno c/o Husqvarna Manufacturing CZ s.r.o. Jesenická 146 79326 Vrbno pod Prádedem Czech Republic Phone: (22) 336 78 90 servis@gardena.pl</p> | <p>Tajikistan ARIERS JV LLC 39, Ayni Street, 7734024 Dushanbe, Tajikistan</p> |
| <p>Belgium Husqvarna Belgium nv Gardena Division Leuvensesteenweg 542 Planet II E 1930 Zaventem België</p> | <p>Germany Husqvarna 9/11 Allée des pierres mayettes 92635 Gennemilliers Cedex France http://www.gardena.com/fr N° AZUR: 0 810 00 78 23 (Prix d'un appel local)</p> | <p>Malta I.V. Portelli & Sons Ltd. 85, 86, Triq San Pawl Rabat - RBT 1240 Phone: (+356) 2145 4289</p> | <p>Portugal Husqvarna Portugal, SA Lagoa - Albarraq 2635 - 595 Rio de Mouro Phone: (+351) 21 922 85 30 Fax: (+351) 21 922 85 36 info@gardena.pt</p> | <p>Turkey Dost Bahçe Yunus Mah. Adil Sk. No:3 Kartal Istanbul 34873 Turkey Phone: (+90) 216 389 39 39 info@dostbahce.com.tr www.dostbahce.com.tr</p> |
| <p>Bosnia / Hercegovina Silk Trade d.o.o. Poslovnna Zona Vila Br. 20 Phone: (+387) 61 165 593 info@silktade.com.ba</p> | <p>Hong Kong Tung Tai Company 151-153 Hoi Bun Road Kwun Tong, Kowloon Hong Kong Phone: (+852) 3583 1662 admin@tungtaico.com</p> | <p>Mexico AFOSA Av. Lopez Mateos Sur # 5019 Col. La Calma 45070 Zapopan, Jalisco, Mexico Phone: (+52) 33 3818-3434 isolis@afosa.com.mx</p> | <p>Romania Madex International Srl Soseaua Odaii 117 - 123, RO 013603 Bucuresti, S1 Phone: (+40) 21 352 7603 madex@ines.ro</p> | <p>Turkmenistan I.E. Orazmuhammedov Nurmuhammet 80 Ataturk, BERKARAR Shopping Center, Ground floor, A770, ASHGABAT 744000, TURKMENISTAN Phone: (+993) 12 468859 Mob: (+993) 62 222887 info@jayhyzmat.com / bekgiyev@jayhyzmat.com www.jayhyzmat.com</p> |
| <p>Brazil Nordtech Maquinas e Motores Ltd. Avenida Juscelino Kubitschek de Oliveira Curitiba 3003 Brazil Phone: (+55) 41 3595-9600 contato@nordtech.com.br www.nordtech.com.br</p> | <p>Hungary Husqvarna Magyarorszáგ Kft. Ezred u. 1 – 3 1044 Budapest Phone: (+36) 1 251-4161 vezesvolgalat.husqvarna@husqvarna.hu</p> | <p>Moldova Convel SRL Republica Moldova, mun. Chisinau, sos. Muncetii 284 Phone: (+373) 22 857 126 www.convel.md</p> | <p>Russia / Россия "Хускварна" 141400, Московская обл., г. Химки, улица Ленинградская, владение 39, стр.6 Бизнес Центр „Химки Бизнес Парк“, помещение OB02_04 http://www.gardena.ru</p> | <p>UAE Al-Futtaim ACE Company L.L.C Building, Al Rebat Street Festival City, Dubai 7880 UAE Phone: (+971) 4 206 6700 ace@alfuttaim.ae</p> |
| <p>Bulgaria AGROLAND България АД бул. 8 Декември, № 13 Офис 5 1700 Студентски град София Тел.: (+359) 24 66 6910 info@agroland.eu</p> | <p>India B K RAMAN AND CO Plot No. 185, Industrial Area, Phase-2, Ram Darbar Chandigarh 160002 India Phone: (+91) 98140 06530 raman@jagannhardware.com</p> | <p>Mongolia Soyolj Gardening Shop Namiid Rd Ulaanbaatar 14230 Mongolia Phone: +976 7777 5080 soyolj@maginet.mn</p> | <p>Saudi Arabia SACO Takhassusi Main Road P.O. Box: 86387 Riyadh 12863 40011 Saudi Arabia Phone: (966) 11 482 8877 webmaster@saco-ksa.com</p> | <p>Uruguay FELI SA Entre Rios 1083 11800 Montevideo Phone: (+598) 2203 1844 info@felisa.com.uy</p> |
| <p>Canada / USA GARDENA Canada Ltd. 100 Summerlea Road Brampton, Ontario L6T 4X3 Phone: (+1) 905 792 93 30 info@gardenacanada.com</p> | <p>Iceland BYKO ehf. Skemmuvegji 2a 200 Kópavogur Phone: (+354) 515 4000 byko@byko.is</p> | <p>Morocco Proekip 64 Rue de la Participation Casablanca-Boches Noires 20303 Morocco Phone: (+212) 661342107 hicham.hafani@proekip.ma</p> | <p>Singapore Hy-Ray PRIVATE LIMITED 40 Jalan Pemimpin #02-08 Tat Ann Building Singapore 577185 Phone: (+65) 6253 2277 info@hyray.com.sg</p> | <p>Ukraine / Україна AT «Альцест» вул Петропавлівська 4 08130, Київська обл. Києво-Святошинський р-н, с. Петропавлівська Борщагівка Україна Тел.: (+38) 0 800 503 000</p> |
| <p>China Husqvarna (Shanghai) Management Co., Ltd. 高世华 (上海) 管理有限公司 Jifeng Square B, No207, Song Hong Rd., Chang Ning District, Shanghai, PRC. 200335 上海市长宁区淞虹路207号明 泰广场B座307楼, 邮编: 200335</p> | <p>Colombia Equipos de Toyama Colombia SAS Cra. 68 D № 25 B 86 Of. 618 Edificio Torre Central Bogota Phone: +57 (1) 703 9520 +57 (1) 703 9522 serviciocliente@toyama.com.co www.toyama.com.co</p> | <p>Nepal Husqvarna Nepal Pvt. Ltd. Kathmandu Phone: (+977) 1 422 2222</p> | <p>Slovak Republic Gardena Service Center Vrbno c/o Husqvarna Manufacturing CZ s.r.o. Jesenická 146 79326 Vrbno pod Prádedem Phone: 0800 154044 servis@gardena.sk</p> | <p>Zimbabwe</p> |