



Operator's manual

SILENO pro

SILENO max

smart SILENO pro

smart SILENO max

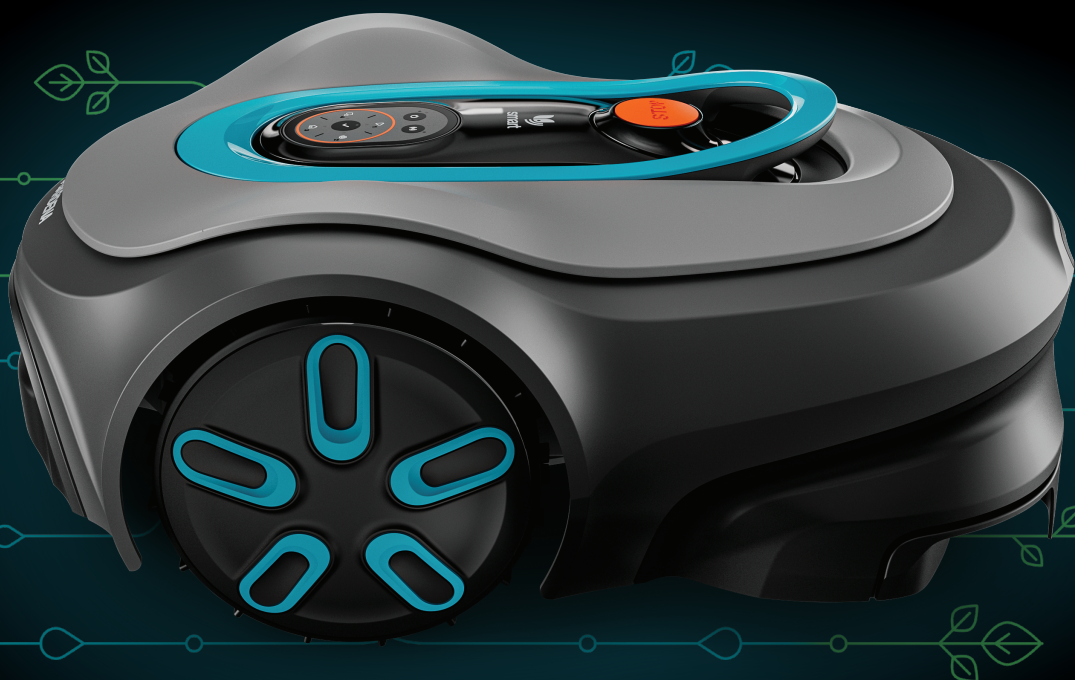

Contents

1 Safety		5 Operation	
1.1 Safety definitions.....	3	5.1 To use the ON/OFF button.....	25
1.2 General safety instructions.....	3	5.2 To start the product.....	25
1.3 Safety instructions for installation.....	4	5.3 Operating modes.....	25
1.4 Safety instructions for operation.....	4	5.4 To stop the product.....	27
1.5 Safety instructions for maintenance.....	4	5.5 To set the product to OFF.....	28
1.6 Battery safety.....	5	5.6 To charge the battery.....	28
1.7 To lift and move the product.....	5	5.7 Cutting height adjustment.....	28
2 Introduction		6 Maintenance	
2.1 Introduction.....	6	6.1 Introduction - maintenance.....	30
2.2 Product overview.....	7	6.2 To remove the body of the product.....	30
2.3 To use the keypad.....	8	6.3 Clean the product.....	30
2.4 LED status indicator on the keypad.....	9	6.4 Replacement of the blades.....	31
2.5 Symbols on the product.....	11	6.5 Firmware update.....	32
2.6 Symbols on the battery.....	11	6.6 Battery.....	33
2.7 General manual instructions.....	11	6.7 Winter service.....	33
2.8 Product damage.....	11	7 Troubleshooting	
3 Installation		7.1 Messages.....	35
3.1 Introduction - Installation.....	12	7.2 Indicator lamp in the charging station.....	40
3.2 Main components for installation.....	12	7.3 Symptoms.....	41
3.3 To prepare for installation.....	12	7.4 Find breaks in the loop wire.....	42
3.4 Before the installation of the wires.....	12	8 Transportation, storage and disposal	
3.5 Installation of the product.....	17	8.1 Transportation.....	45
3.6 To put the wire into position with stakes.....	20	8.2 Storage.....	45
3.7 To bury the boundary wire or the guide wire.....	20	8.3 Disposal.....	45
3.8 To extend the boundary wire or the guide wire... 20		9 Technical data	
3.9 After the installation of the product.....	20	9.1 Technical data.....	46
3.10 To download and pair with the GARDENA Bluetooth® app.....	21	9.2 Registered trademarks.....	47
3.11 To download and pair with the GARDENA smart system app.....	21	10 Declaration of Conformity	
4 Settings		10.1 Original EU Declaration of Conformity.....	48
4.1 To do the Schedule settings.....	22	11 Applicable to UK market	
4.2 Dynamic starting points.....	22	11.1 Original UK Declaration of Conformity.....	50
4.3 Drive Past Wire function.....	22	11.2 Statement of compliance.....	51
4.4 To set the charging station starting point.....	22		
4.5 SensorControl.....	23		
4.6 ECO mode.....	23		
4.7 Trim-to-Edge.....	23		
4.8 Frost Sensor.....	23		
4.9 ZoneProtect.....	23		
4.10 New loop signal.....	23		
4.11 PIN code.....	24		
4.12 Reset all user settings.....	24		

1 Safety

1.1 Safety definitions

Warnings, cautions and notes are used to point out specially important parts of the manual.



WARNING: Used if there is a risk of injury or death for the operator or bystanders if the instructions in the manual are not obeyed.



CAUTION: Used if there is a risk of damage to the product, other materials or the adjacent area if the instructions in the manual are not obeyed.

Note: Used to give more information that is necessary in a given situation.

1.2 General safety instructions



WARNING: Read the warning instructions that follow before you use the product.

- Read the Operator's manual carefully and make sure you understand the instructions before you use the product. Keep for future reference.
- This appliance is not intended for use by children or persons with reduced physical, sensory or mental capabilities (that could affect a safe handling of the product), or lack of experience and knowledge, unless they have been given supervision or instruction concerning use of the appliance by a person responsible for their safety. However, EU requirements allows this appliance to be used by children aged from 8 years and above and persons with reduced physical, sensory or mental capabilities or lack of experience and knowledge, if they have been given supervision or instruction concerning use of the appliance in a safe way and understand the hazards involved. Children shall not play with the appliance. Cleaning and user maintenance shall not be made by children without supervision.
- The product must only be used with the equipment recommended by GARDENA. All other types of use are incorrect.
- Do not let children less than 9 years of age be in the work area during operation.
- Always keep a distance of minimum 3 m/10 ft from the product during operation. Children and animals must be supervised at all times during operation.
- The product is not a toy. The blades of the product can cause injury to persons and animals.
- To set the product to OFF, go behind the product and push the STOP button. You can use the app to pause the product if it is applicable for your product. When the product is set to OFF, wait minimum 3 seconds before you move the product.
- Do not use the product when persons, especially children, or animals are in the work area.
- Warning signs must be put around the work area of the product if it operates in public areas. The signs must have the text that follows: Warning! Automatic lawn mower! Keep away from the machine! Supervise children!
- Do not touch moving hazardous parts, such as the blade disc, before it has come to a complete stop.
- Set the product to OFF before you clear a blockage, do maintenance or examine the product, and if the product starts to vibrate abnormally. Examine the product for damage before you start the product again. Do not use the product if it is damaged.
- If an injury or accident occur, get medical aid.
- Do not put power supply cable and extension cable in the work area. This can cause damage to the cables.
- Do not connect a damaged cable or plug, or touch a damaged cable, before it is disconnected from the power outlet. Disconnect the plug from the power outlet if the cable becomes damaged while in operation. A worn or damaged cable increases the risk of electrical shock. A damaged cable must be replaced by service personnel.
- When you connect the power supply to the power outlet, use a residual-current device (RCD) with a tripping current of maximum 30 mA.
- Only charge the product in the included charging station. For safe disposal of the battery, refer to *Winter service on page 33*. Incorrect use may result in electric shock, overheating or leaking of corrosive liquid from the battery. In the event of leakage of electrolyte, flush with water/neutralizing agent. Get medical aid if corrosive liquid comes in your eyes.
- Use only original batteries recommended by GARDENA. Product safety cannot be guaranteed with other than original batteries. Do not use non-rechargeable batteries.
- Follow the installation instructions that includes to specify the work area, refer to *Installation on page 12*.
- Follow the instructions about to start and operate the product, refer to *Operation on page 25*.
- If there is a risk of thunderstorm, GARDENA recommends that the power supply and all the

wires to the charging station are disconnected to decrease the risk of damage to electrical components. Connect the power supply and all the wires again if there is no longer a risk of thunderstorm. It is important that all wires are connected correctly.

- Follow the maintenance instructions and if necessary use GARDENA original spare parts, refer to *Maintenance on page 30*.
- For technical data such as weight, dimensions and noise emission values, refer to *Technical data on page 46*.
- The operator is responsible for accidents or dangers that occurs to other persons or property.
- The product must only be operated, maintained and repaired by persons that are fully conversant with its special characteristics and safety regulations.
- It is not permitted to change the initial design of the product.
- Obey national regulations about electrical safety.
- GARDENA does not guarantee full compatibility between the product and other types of wireless systems such as remote controls, radio transmitters or equivalent.
- The built-in alarm is very loud. Be careful, especially if the product is handled indoors.
- Operation and storage temperature range is 0-50 °C / 32-122 °F. Temperature range for charging is 0-45 °C / 32-113 °F. Too high temperatures can cause damage to the product.

1.3 Safety instructions for installation



WARNING: Read the warning instructions that follow before you use the product.

- Do not install the charging station, including any accessory, at a location that is below, or within 60 cm / 24 in. from, any combustible material. In case of malfunction, heating of the charging station and the power supply may occur and create a potential risk of fire.
- Do not put the power supply at a height where there is a risk it can be put in water. Do not put the power supply on the ground.
- Do not encapsulate the power supply. Condensed water can harm the power supply and increase the risk of electrical shock.
- Do not install the charging station where there are pests, for example ants.
- Applicable to USA/Canada. If power supply is installed outdoors: Risk of Electric Shock. Install only to a covered Class A GFCI receptacle (RCD) that has an enclosure that is weatherproof with the attachment plug cap inserted or removed.

- Do not install the charging station where there is a risk of standing water.

1.4 Safety instructions for operation



WARNING: Read the warning instructions that follow before you use the product.

- Keep your hands and feet away from the rotating blades. Do not put your hands or feet near or below the product when it is set to ON.
- Use the park mode or set the product to OFF when persons, especially children or animals are in the work area. Refer to *To set the product to OFF on page 28*. GARDENA recommends to set the product to operate when the work area has no activity. The product can cause injury to animals at night in work area, for example hedgehogs. Refer to *Park / Schedule on page 26*.
- Make sure that there are no objects such as stones, branches, tools or toys on the lawn. The blades can be damaged if it hits an object.
- Do not lift the product or move it when it is set to ON.
- Do not let the product collide with persons or animals. If a person or animal comes in the way of the product, stop the product immediately. Refer to *To stop the product on page 27*.
- Do not put objects on top of the product or its charging station.
- Do not use the product if the **STOP** button does not work.
- Always set the product to OFF when it is not in operation. The product can only start when you enter the correct PIN code.
- Do not use the product at the same time as a pop-up sprinkler. Use the *Schedule* function so the product and pop-up sprinkler do not operate at the same time. Refer to *Park / Schedule on page 26*.
- Do not let the product operate when there is standing water in the work area. For example when heavy rain forms pools of water.

1.5 Safety instructions for maintenance



WARNING: Read the warning instructions that follow before you do maintenance on the product.

- Set the product to **OFF** when you do maintenance on the product.
- Do not use a high-pressure washer to clean the product. Do not use solvents to clean the product.
- Disconnect the plug to the charging station before you clean or do maintenance of the charging station.

1.6 Battery safety



WARNING: Read the warning instructions that follow before you use the product.

- Lithium-ion batteries can explode or cause fire if disassembled, short-circuited, exposed to water, fire, or high temperatures. Handle carefully, do not dismantle, open the battery or use any type of electrical/mechanical abuse. Avoid storage in direct sunlight.

1.7 To lift and move the product



WARNING: The product must be set to OFF before you lift the product. The product is disabled when the indicator on the **ON/OFF** button goes off.



CAUTION: Do not lift the product when it is parked in the charging station. It can cause damage to the charging station and/or the product. Push the **STOP** button and pull the product out of the charging station before you lift it.

To safely move the product from or in the work area:

1. Push the **STOP** button to stop the product.

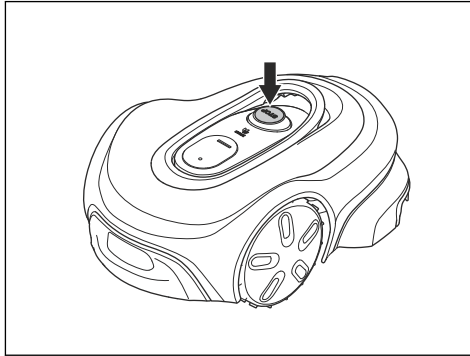

2. Push the **ON/OFF** button for 3 seconds to set the product to OFF.

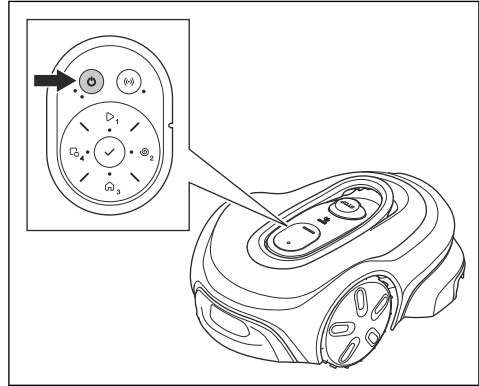

3. Make sure that the product is disabled. The indicator on the **ON/OFF** button goes off when the product is disabled. Refer to *To use the keypad on page 8*.
4. Lift the product by the handle with the blade disc away from your body.



2 Introduction

2.1 Introduction

Serial number:
PIN code:
Product registration key:

The serial number is on the product carton and on the product rating plate. Refer to *Product overview on page 7*.

- Use the serial number to register your product on www.gardena.com.

2.1.1 Support

For support about the GARDENA product, speak to your GARDENA service.

2.1.2 Product description

Note: GARDENA regularly updates the appearance and function of the products. Refer to *Support on page 6*.

The product is a robotic lawn mower. The product has a battery power source and cuts the grass automatically. It continuously alternates between mowing and charging. The movement pattern is random, which means that the lawn is mowed evenly and with less wear. The boundary wire and the guide wire controls the movement of the product within the work area. Sensors in the product senses when it is approaching the boundary wire. The front of the product always passes the boundary wire by a specific distance before the product turns around. When the product hits an obstacle or approaches the boundary wire the product selects a new direction.

You can select the operation settings in the app or with the buttons on the keypad of the product. The app and the LED status indicator show the operation mode of the product.

2.1.2.1 Mowing technique

The frequent cutting technique improves the grass quality and decreases the use of fertilizers. Collection of

grass is not necessary. The *Trim-to-Edge* function and the edge cutting disc makes it possible for the product to cut near the edges of the lawn.

2.1.2.2 Find the charging station

The product operates until the battery state of charge is low, then the product starts to go to the charging station. The guide wire is put from the charging station to a remote part of the work area or through a narrow passage. The guide wire is connected with the boundary wire to make it easier and faster for the product to find the charging station.

2.1.2.3 Connectivity

The GARDENA Bluetooth® app or the GARDENA smart system app can be used to operate the product and to make the settings of the product. You can only use one app at the time.

The GARDENA Bluetooth® app is used to quickly and easily access the settings and operation of the product. You can only control the product with the GARDENA Bluetooth® app when the mobile device is in Bluetooth®-range of the product. Refer to *To download and pair with the GARDENA Bluetooth® app on page 21*.

The GARDENA smart Gateway is purchased separately. Install the GARDENA smart Gateway and connect the product to use the GARDENA smart system app. The GARDENA smart system app has more functions and remote access to the product. Refer to *To download and pair with the GARDENA smart system app on page 21*.

2.2 Product overview

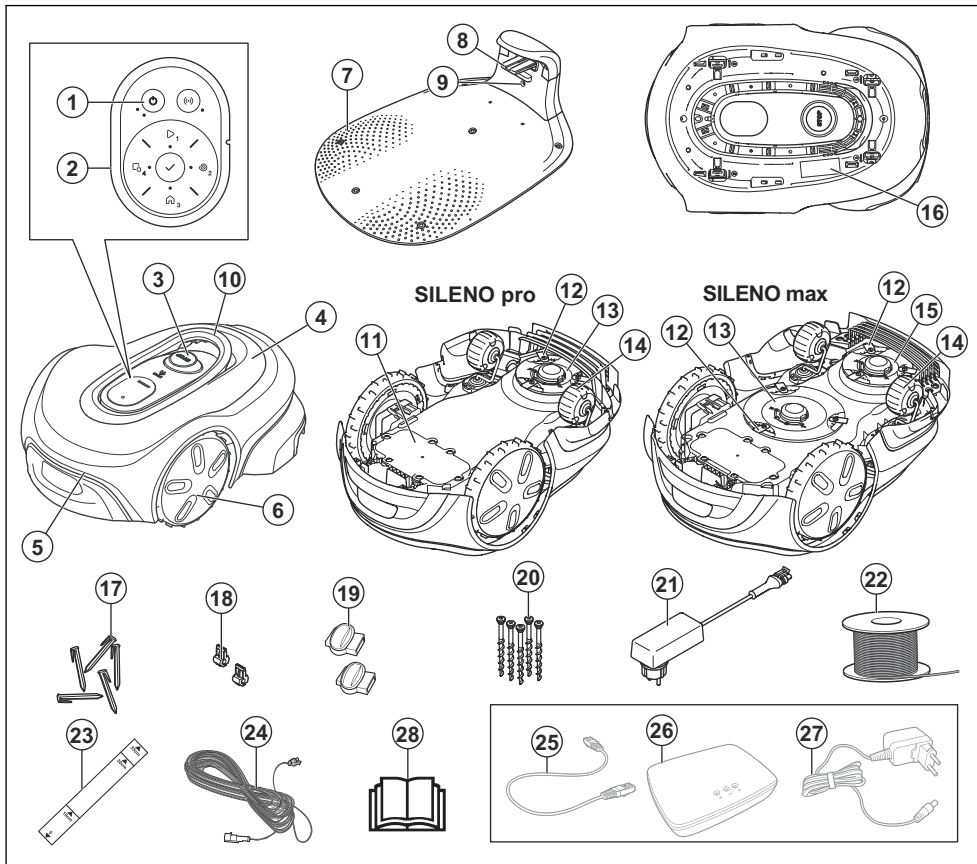

- | | |
|-------------------------------------------------------------------------------------------------------------------------------------------------------------------------------------------------------------------------------------------------------------------------------------------------------------------------------------------------------------------------------------------------------------------------------|------------------------------------------------------------------------------------------------------------------------------------------------------------------------------------------------------------------------------------------------------------------------------------------------------------------------------------------------------------------------------------------------------------------------------------------------------------------------------------------------------------------------------------------------------------|
| <ol style="list-style-type: none"> 1. ON/OFF button 2. Keypad 3. Stop button 4. Top cover 5. Body 6. Front wheels 7. Charging station 8. Contact plates 9. LED indicator of the charging station 10. Handle 11. Chassis box with electronics, battery and motors 12. Cutting system 13. Blade disc | <ol style="list-style-type: none"> 14. Rear wheels 15. Edge cut disc 16. Rating plate¹ 17. Stakes 18. Connector for the loop wire 19. Couplers for loop wire 20. Screws to attach the charging station 21. Power supply² 22. Loop wire for boundary wire and guide wire 23. Measurement gauge for installation of the boundary wire (the measurement gauge is removed from the carton of the product) 24. Low-voltage cable |
|-------------------------------------------------------------------------------------------------------------------------------------------------------------------------------------------------------------------------------------------------------------------------------------------------------------------------------------------------------------------------------------------------------------------------------|------------------------------------------------------------------------------------------------------------------------------------------------------------------------------------------------------------------------------------------------------------------------------------------------------------------------------------------------------------------------------------------------------------------------------------------------------------------------------------------------------------------------------------------------------------|

¹ Found below the top cover. The top cover must be removed to access it.

² The appearance can be different for different markets.

- 25. GARDENA smart Gateway LAN-cable³
- 26. GARDENA smart Gateway⁴
- 27. GARDENA smart Gateway power supply⁵
- 28. Operator's manual, Quick guide and instruction for the GARDENA smart system

2.3 To use the keypad

Use the keypad on the product to operate the product. Push the button for 1 second or 3 seconds to set an operating mode, refer to *Operating modes on page 25*. When you push the button for 3 seconds, the LED on the button flashes 3 times when a operating mode is selected. You must enter the PIN code for the product before you can select an operating mode.

- Use the **ON/OFF** button (A) to set the product to ON or OFF.
- Use the **Start** button (B) to start the operation of the product on the main area.
- Use the **Secondary area** button (C) to cut in a work area that does not have a charging station. Refer to *Secondary area on page 27*.
- Use the **OK** button (D) do the selections.
- Use the **Connectivity** button (E) to enable the pairing operation for Bluetooth® and the GARDENA smart system.

- Use the **SpotCut** button (F) to set the product to operate in a spiral pattern. The product cuts the grass in the area where it started.
- Use the **Park** button (G) to send the product to the charging station.

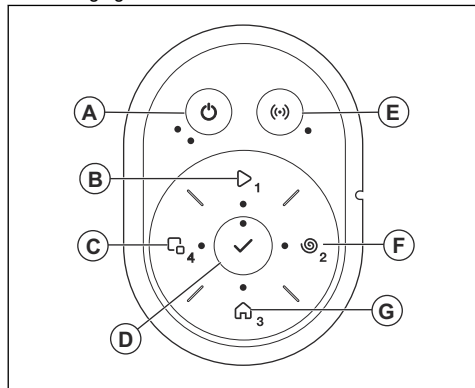

³ Purchased separately.

⁴ Purchased separately.

⁵ Purchased separately.

2.4 LED status indicator on the keypad

The LED status indicator on the keypad shows the status of the product. There are 4 light modes on the LED indicator: the light flashes quickly (A) the light is solid (B), the light is out (C), and the light pulsates (D).

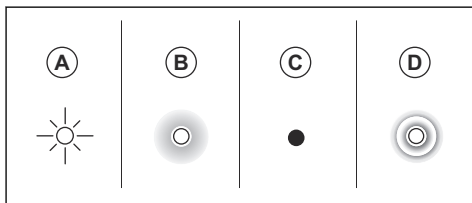

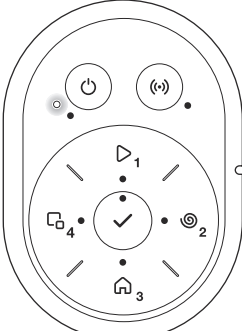
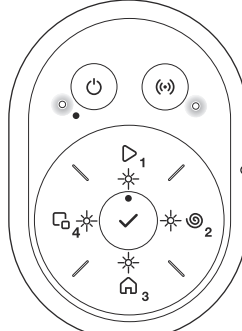
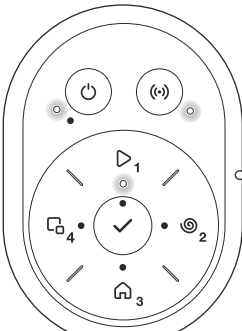
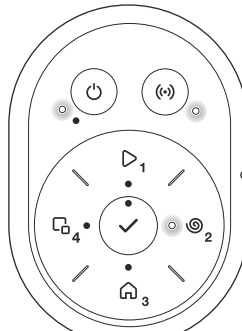
<p>Standby.</p> 	<p>Waiting for PIN code.</p> 
<p>Cutting main area according to the set <i>Schedule</i> or in operating mode <i>Override schedule</i>.</p> 	<p>Cutting, in operating mode <i>SpotCut</i>.</p> 

Parked until the next schedule or Parked until further notice.

Cutting in operating mode Secondary area.

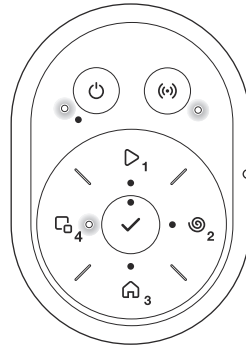
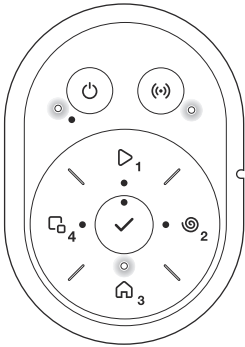

Error.

Error after 3 minutes.

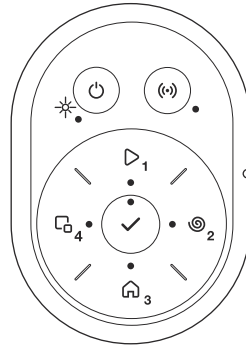
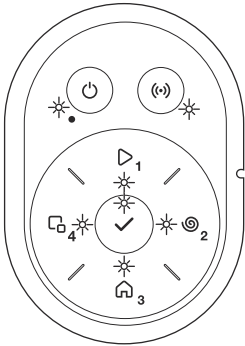

Charging or installs firmware update.

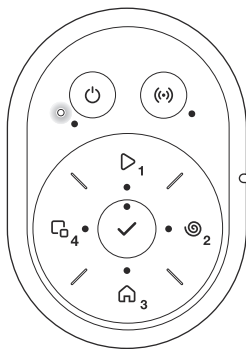

2.5 Symbols on the product

These symbols can be found on the product. Study them carefully.



WARNING: Read the user instructions before operating the product.



WARNING: Disable the product before working on or lifting the product.



WARNING: Keep a safe distance from the product when operating. Keep your hands and feet away from the rotating blades.



WARNING: Do not ride on the product. Do not put your hands or feet close to or under the product.

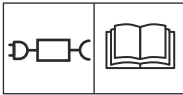

Use a detachable power supply as defined on the rating plate next to the symbol.



This product complies with the applicable EU Directives.



This product complies with the applicable UK Directives.



It is not permitted to dispose this product as normal household waste. Ensure that the product is recycled in accordance with local legal requirements.



The low-voltage cable must not be shortened, extended or spliced.

Do not use a trimmer nearby the low-voltage cable. Be careful when trimming edges where the cables are placed.

2.6 Symbols on the battery



WARNING: Lithium-ion batteries can explode or cause fire if disassembled, short-circuited or handled roughly. Do not expose to water, fire or high temperature.



Read the user instructions.



Do not discard the battery into fire and do not expose the battery to a heat source.



Do not immerse the battery into water.

2.7 General manual instructions

The following system is used in the Operator's manual to make it easier to use:

- Text written in *italics* is a text that is shown in the app or is a reference to another section in the Operator's manual.
- Text written in **bold** is one of the buttons on the product.

2.8 Product damage

We are not responsible for damages to our product if:

- the product is incorrectly repaired.
- the product is repaired with parts that are not from the manufacturer or not approved by the manufacturer.
- the product has an accessory that is not from the manufacturer or not approved by the manufacturer.
- the product is not repaired at an approved service center or by an approved authority.

3 Installation

3.1 Introduction - Installation

Refer to www.gardena.com for more information about installation and instruction videos.

We recommend you to update the firmware before you install the product to make sure that the product has the latest firmware. Refer to *Firmware update on page 32*.



WARNING: Read and understand the safety chapter before you install the product.



CAUTION: Use original spare parts and installation material.

3.2 Main components for installation

The installation involves the following components:

- A robotic lawn mower that mows the lawn automatically.
- A charging station, which has 3 functions:
 - To send control signals along the boundary wire.
 - To send control signals along the guide wire so that the product can follow the guide wire to specific remote areas in the garden and can find its way back to the charging station.
 - To charge the product.
- A power supply, which is connected to the charging station and a 100-240V power outlet.
- Loop wire, which is laid around the work area and around objects and plants that the product must not run into. The loop wire is used both as boundary wire and guide wire.

3.3 To prepare for installation

Read the installation chapter before you start the installation. Prepare the installation carefully to make the product operate satisfactorily.

- Make a blueprint of the work area and include all obstacles. This makes it easier to examine where to put the charging station, the boundary wire and the guide wire.
- Make a mark on the blueprint where to put the charging station, the boundary wire and the guide wire.
- Make a mark on the blueprint where the guide wire connects to the boundary wire. Refer to *To install the guide wire on page 19*.
- Fill in holes in the lawn to make it level.



CAUTION: Holes with water in the lawn can cause damage to the product.

- Cut the grass and trim the edges before you install the product. Make sure that the grass is maximum 4 cm / 1.6 in.

Note: The first weeks after installation the sound level when the product cuts the grass can be higher than usual. The sound level decreases after some time.

3.4 Before the installation of the wires

You can select to attach the wires with stakes or bury them. You can use the 2 procedures for the same work area.



CAUTION: If you use a dethatcher in the work area, bury the boundary wire and the guide wire to prevent them from damage.

3.4.1 To examine where to put the charging station

- Keep a minimum 2 m / 6.6 ft. of free space in front of the charging station. Refer to *To examine where to put the guide wire on page 16*.
- Keep a minimum of 30 cm / 12 in. of free space to the right and left of the center of the charging station.

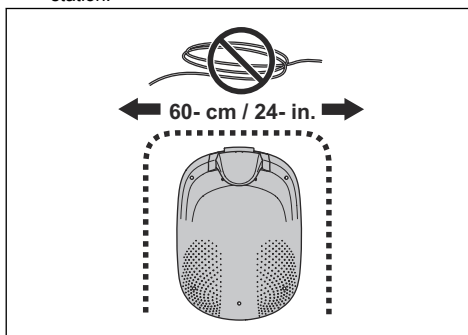

- Put the charging station near a power outlet.
- Put the charging station on a level surface.
- The baseplate of the charging station must not be bent.

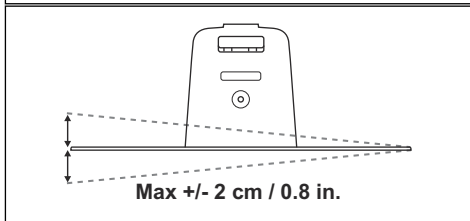
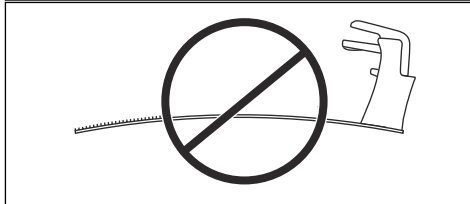
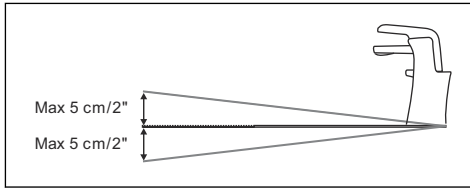

- If the work area has two parts separated with a steep slope, we recommend to put the charging station in the lower section.
- Put the charging station in an area with protection from the sun.
- If the charging station is installed on an island, make sure to connect the guide wire to the island. Refer to *To make an island on page 15*.

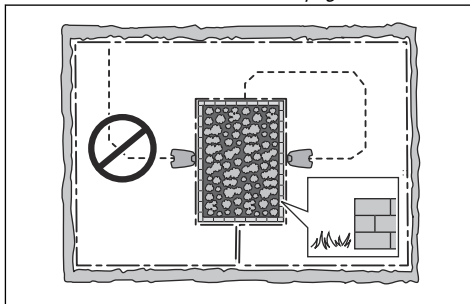

3.4.2 To examine where to put the power supply



WARNING: Do not cut or extend the low-voltage cable. There is a risk of electrical shock.



CAUTION: Make sure that the blades on the product do not cut the low-voltage cable.



CAUTION: Do not put the low-voltage cable in a coil or below the charging station plate. The coil causes interference with the signal from the charging station.



- Put the power supply in an area with a roof and protection from the sun and rain.
- Put the power supply in an area with good airflow.
- Use a residual-current device (RCD) with a tripping current of maximum 30 mA when you connect the power supply to the power outlet.

Low-voltage cables of different lengths are available as accessories.

3.4.3 To examine where to put the boundary wire



CAUTION: There must be a barrier of minimum 15 cm / 6 in. in height between the boundary wire and water bodies, slopes, precipices or public roads. This will prevent damage to the product.



CAUTION: Do not let the product operate on gravel.



CAUTION: Do not make sharp bends when you install the boundary wire.



CAUTION: For careful operation without noise, isolate all obstacles such as trees, roots and stones.

The boundary wire should be put as a loop around the work area. Sensors in the product senses when the product approaches the boundary wire, and the product selects another direction.

To make the connection easier between the guide wire and the boundary wire, it is recommended to make an eyelet where the guide wire will be connected. Make the

eyelet with approximately 20 cm / 8 in. of the boundary wire.

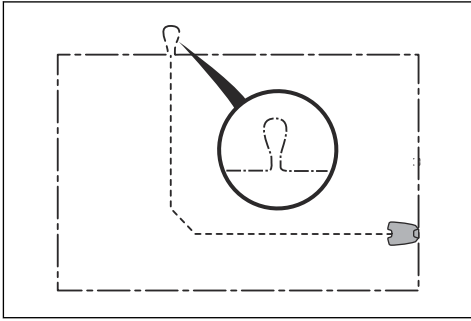

Note: Make a blueprint of the work area before you install the boundary wire and guide wire.

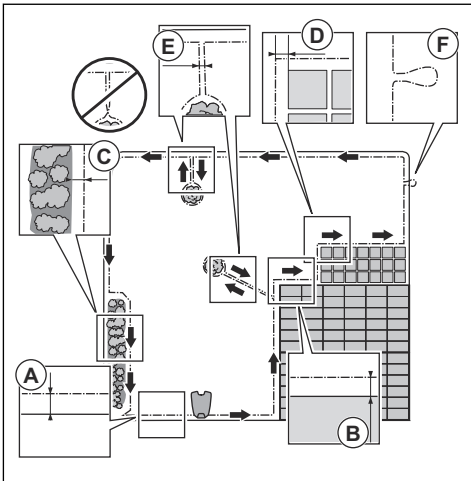

- Put the boundary wire around all of the work area (A). Adapt the distance between the boundary wire and obstacles.
- Put the boundary wire 35 cm / 14 in. (B) from an obstacle that is more than 2 cm / 0.8 in. high.

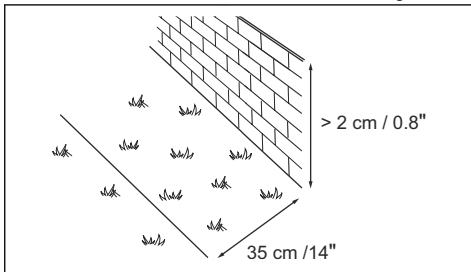

- Put the boundary wire 30 cm / 12 in. (C) from an obstacle that is 1-2 cm / 0.4-0.8 in. high.

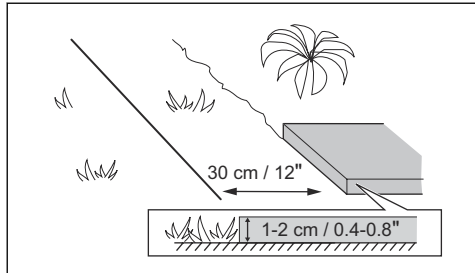

- Put the boundary wire 10 cm / 4 in. (D) from an obstacle that is less than 1 cm / 0.4 in. high.

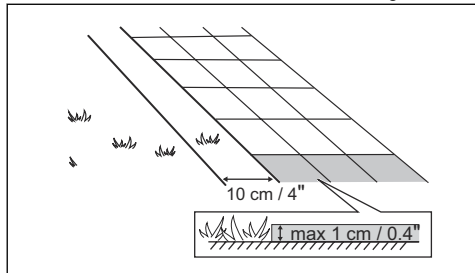

- If you have a paving stone path that is in level with the lawn, put the boundary wire below the paving stone.
- If you make an island, put the boundary wire that runs to and from the island near together (E). Put the wires in the same stake. Refer to *To make an island on page 15*.
- Make an eyelet (F) where the guide wire is to be connected to the boundary wire.

3.4.3.1 To put the boundary wire in a slope

SILENO pro can operate in 25% slopes and SILENO max can operate in 35% slopes. Slopes that are too steep must be isolated with the boundary wire. The gradient (%) is calculated as the vertical height divided by the horizontal distance.

Example:

- $10 \text{ cm} / 100 \text{ cm} = 10\%$.
- $4 \text{ in} / 40 \text{ in} = 10\%$.

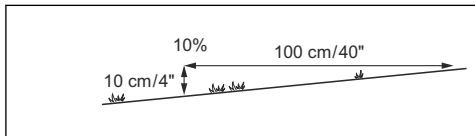

- For slopes steeper than 25-35% inside the work area, isolate the slope with boundary wire.

- For slopes steeper than 15% along the outer edge of the lawn, put the boundary wire 20 cm / 8 in. (A) from the edge.

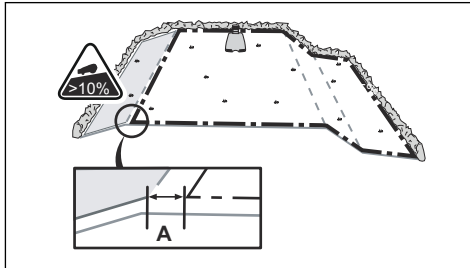

- For slopes adjacent to a public road, put a barrier of minimum 15 cm / 6 in. along the outer edge of the slope. You can use a wall or a fence as a barrier.

3.4.3.2 Passages

A passage is a section that has boundary wire on each side and that connects 2 parts of the work area. The distance between the boundary wire on each side in the passage must be a minimum of 60 cm / 24 in.

Note: If a passage is less than 2 m / 6.5 ft. wide, install a guide wire through the passage.

The recommended minimum distance between the guide wire and the boundary wire is 30 cm / 12 in. The product always runs to the left of the guide wire as seen facing the charging station. It is recommended to have as much free area as possible to the left of the guide wire (A).

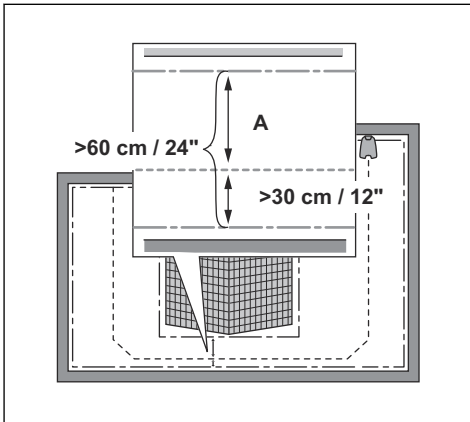

3.4.3.3 To make an island



CAUTION: Do not put a section of boundary wire across the other. The sections of boundary wire must be parallel.



CAUTION: Do not put the guide wire across the boundary wire.



CAUTION: Isolate or remove obstacles that are less than 15 cm / 5.9 in. in height. Isolate or remove obstacles that slope slightly, for example, stones, trees or roots. This will prevent damage to the blades of the product.

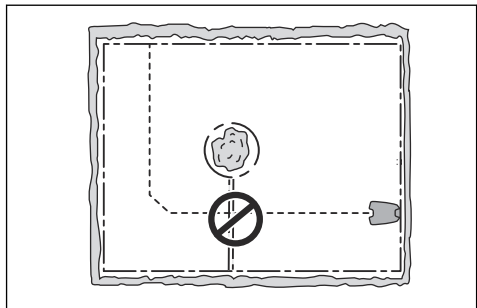

To make an island, isolate areas in the work area with the boundary wire. We recommend to isolate all stable objects in the work area.

Some obstacles are resistant to a collision, for example, trees or bushes that are more than 15 cm / 5.9 in. in height. The product will collide with the obstacle and then select a new direction.

- Put the boundary wire to and around the obstacle to make an island.
- Put the 2 sections of boundary wire to and from the island close together. This will make the product run across the wire.
- Put the 2 sections of boundary wire in the same stake.

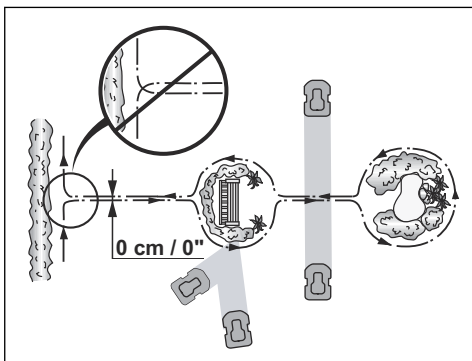

3.4.3.4 To make a secondary area

Make a secondary area (B) if the work area has 2 areas that are not connected with a passage. The work area with the charging station is the main area (A).

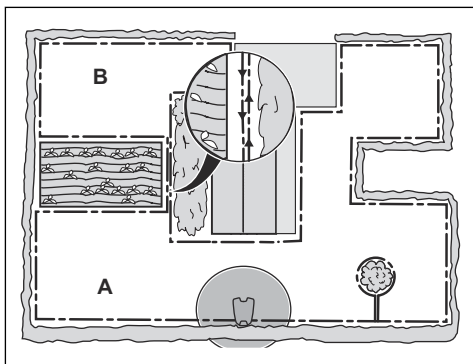

Note: The product must be manually moved between the main area and the secondary area.

- Put the boundary wire around the secondary area (B) to make an island. Refer to *To make an island on page 15*.

Note: The boundary wire must be put as 1 loop around all of the work area (A + B).

Note: When the product cuts grass in the secondary area, the *Secondary area* mode must be selected. Refer to *Secondary area on page 27*.

3.4.4 To examine where to put the guide wire

Put the guide wire from the charging station through the work area and connect it to the boundary wire.

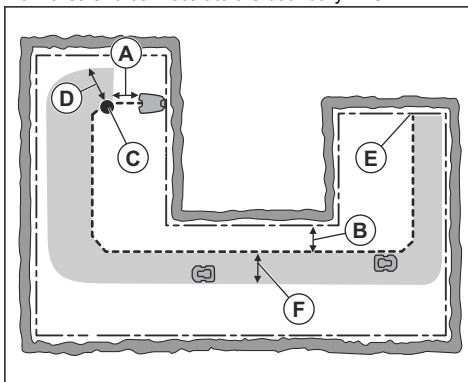

- Put the guide wire in a line at a minimum of 1 m / 3.3 ft. in front of the charging station (A).
- Put the guide wire minimum 30 cm / 1 ft. from the boundary wire (B).
- Starting point (C). Refer to *To set the charging station starting point on page 22*.
- Minimum distance 60 cm / 2 ft. from the starting point to perpendicular to the boundary wire (D). Refer to *To install the guide wire on page 19*.
- Where the guide wire is connected to the boundary wire (E).
- Guide corridor (F). The product always runs to the left of the guide wire as seen facing the charging station. Make sure that the guide wire has as much free area as possible to the left of the guide wire. The guide corridor can be maximum 1.2 m / 4 ft.

Note: The product always runs in the guide corridor but changes the distance to the guide wire.

- Do not make sharp bends when you install the guide wire.

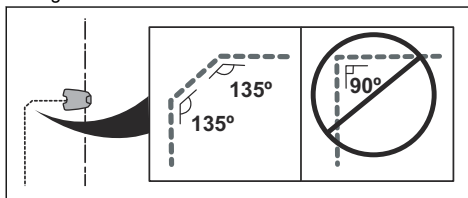

3.4.5 To examine where to put the guide wire for the LONA installation

This function is only available for smart models connected to the GARDENA smart Gateway. Follow the

instructions below if you install a virtual work area with the LONA function.

- Put the guide wire in all parts of the work area.
- We recommend to put the guide wire in a line in all parts of the work area.

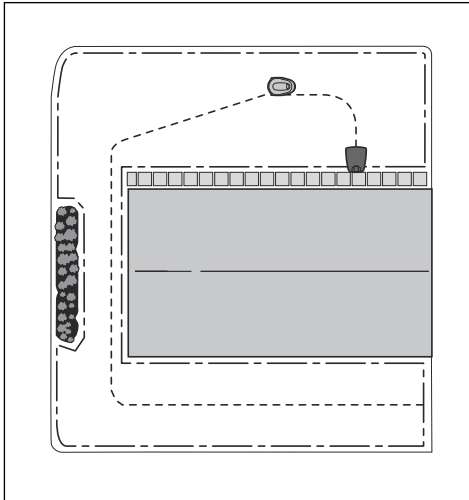

- If it is necessary, you can install the guide wire in a loop. Put the guide wire in a loop to the right of the charging station. Put the guide wire at a minimum distance of 1.5 m / 4.9 in. (A) from the other section of the guide wire.

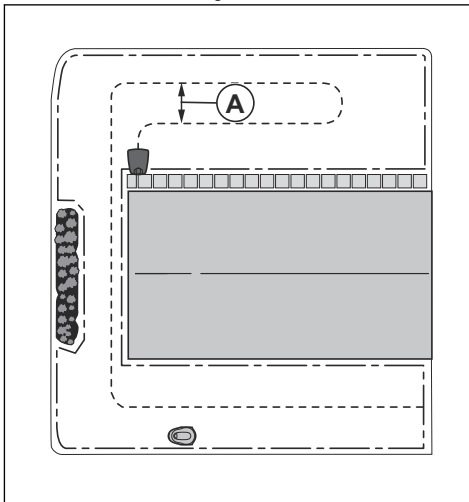

3.4.6 Work area examples

- If the charging station is put in a small area (A), make sure that the distance to the boundary wire is

at a minimum 2 m / 6.6 ft. in front of the charging station.

- If the work area has a passage (B) with no guide wire installed, the minimum distance between the boundary wires is 2 m / 6.5 ft. With a guide wire installed through the passage, the minimum distance between the boundary wires is 60 cm / 24 in. Use the *CorridorCut* function to cut this passage. Refer to *Starting points and CorridorCut* on page 22.
- If the work area has areas which are connected by a narrow passage (B), you can set the product to first follow and then leave the guide wire after a certain distance (C). The settings can be changed in *Starting points and CorridorCut* on page 22.
- If the work area includes a secondary area (D), refer to *Secondary area* on page 27. Put the product in the secondary area and select *Secondary area mode*.

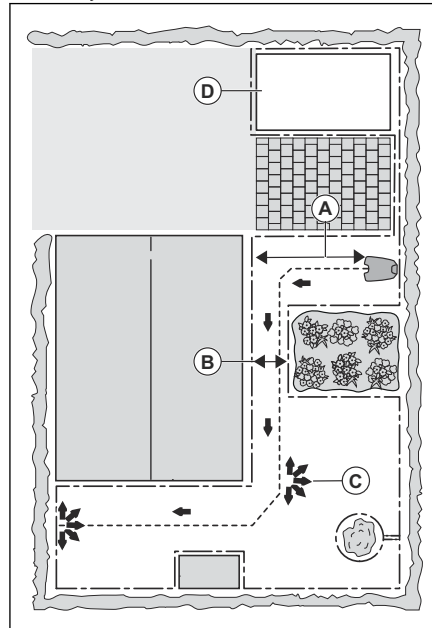

3.5 Installation of the product

3.5.1 Installation tools

- Hammer/plastic mallet: To simplify putting the stakes into the ground.
- Edge cutter/straight spade: To bury the boundary wire.
- Combination pliers: For cutting the boundary wire and pressing the connectors together.
- Adjustable plier: For pressing the couplers together.

3.5.2 To install the charging station



CAUTION: Do not make new holes in the charging station plate.



CAUTION: Do not put your feet on the baseplate of the charging station.



WARNING: Make sure that the plugs of the low-voltage cable and the power supply unit are clean and dry before you connect them.

When connecting the power supply, only use a power outlet that is connected to an residual-current (RCD) device.

1. Read and understand the instructions about the charging station. Refer to *To examine where to put the charging station on page 12*.
2. Connect the cable of the charging module to the cable of the charging station.

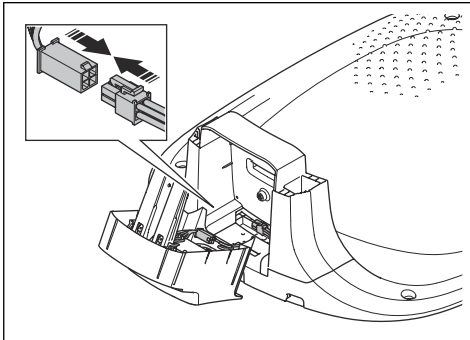

3. Tilt the charging module (A) and push it into position into the charging station (B).

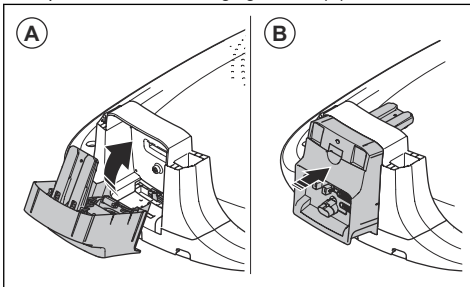

4. Install the charging station top to the charging station.

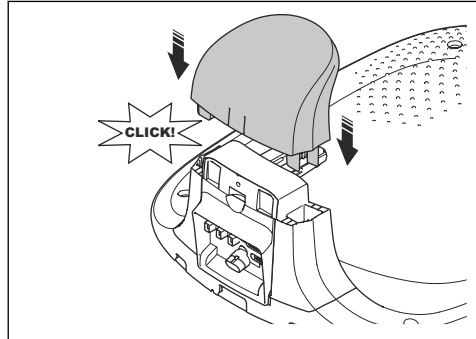

5. If it is necessary to remove the charging module, push the clips from below with the hex key. Remove the charging module.

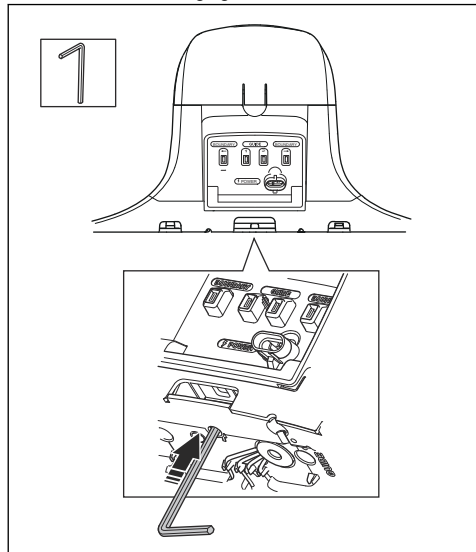

6. Put the charging station in the selected area.

Note: Do not attach the charging station to the ground with the screws until the guide wire is installed. Refer to *Introduction on page 6*.

7. Connect the low-voltage cable to the charging station.
8. Put the power supply at a minimum height of 30 cm / 12 in.

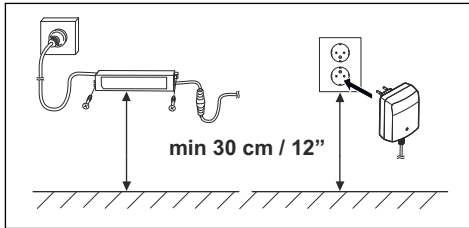

9. Connect the power supply cable to a 100-240V power outlet.

Note: The product can be put in the charging station to charge while you install the boundary wire and the guide wire.

10. Put the low-voltage cable in the ground with stakes or bury the cable. Refer to *To put the wire into position with stakes on page 20* or *To bury the boundary wire or the guide wire on page 20*.
11. Connect the wires to the charging station after the installation of boundary wire and guide wire is complete. Refer to *To install the boundary wire on page 19* and *To install the guide wire on page 19*.
12. Attach the charging station to the ground with the supplied screws after the guide wire is installed. Refer to *To install the guide wire on page 19*.

3.5.3 To install the boundary wire



CAUTION: Do not put remaining wire in a coil. The coil causes interference with the product.

1. Put the boundary wire around all of the work area. Start and complete the installation behind the charging station.
2. Open the connector and put the boundary wire in the connector.

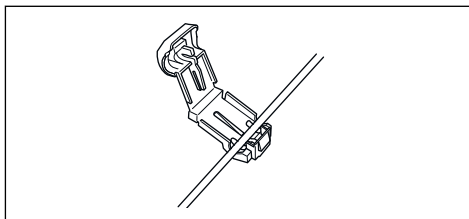

3. Close the connector with a pair of pliers.

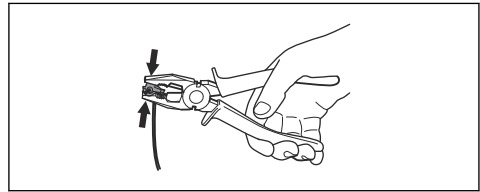

4. Cut the boundary wire 1-2 cm / 0.4-0.8 in. above each connector.
5. Push the right connector onto the metal pin on the charging station with the mark "BOUNDARY->".
6. Push the left connector onto the metal pin on the charging station with the mark "<-BOUNDARY".

3.5.4 To install the guide wire



CAUTION: Twinned cables, or a screw terminal block that is insulated with insulation tape are not satisfactory splices. Soil moisture will cause the wire to oxidize and after a time result in a broken circuit.

1. Open the connector and put the wire in the connector.
2. Close the connector with a pair of pliers.
3. Cut the guide wire 1-2 cm / 0.4-0.8 in. above each connector.
4. Push the guide wire through the slot in the charging station plate.
5. Push the connector onto the metal pin on the charging station with the mark "GUIDE 1 / GUIDE 2".
6. Disconnect the charging station from the power outlet.
7. Put the end of the guide wire at the eyelet on the boundary wire.
8. Cut the boundary wire with a pair of wire cutters.
9. Connect the guide wire to the boundary wire with a coupler.

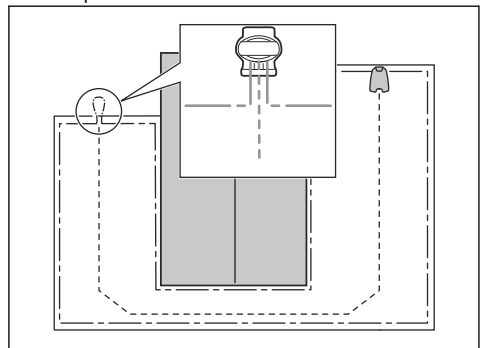

- a) Put the 2 ends of the boundary wire and the end of the guide wire into the coupler.

Note: Make sure that you can see the ends of the wires through the transparent area of the coupler.

- b) Push down the cover on the coupler with adjustable pliers to attach the wires in the coupler.

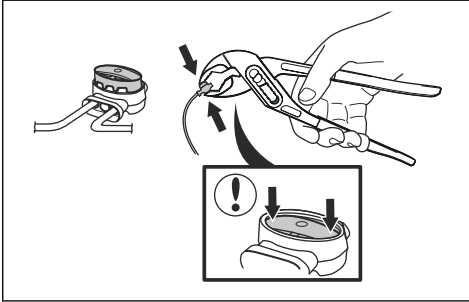

10. Attach the guide wire to the ground with stakes or bury the guide wire in the ground. Refer to *To put the wire into position with stakes on page 20* or *To bury the boundary wire or the guide wire on page 20*.
11. Connect the charging station to the power outlet.

3.6 To put the wire into position with stakes



CAUTION: Make sure that the stakes hold the boundary wire and the guide wire against the ground.



CAUTION: Cutting the grass too low right after installation can damage the wire insulation. Damage to the insulation may not cause disruptions until several weeks or months later.

1. Put the boundary wire and the guide wire on the ground.
2. Put the stakes at a maximum of 100 cm / 40 in. distance from each other.
3. Attach the stakes to the ground with a hammer or a plastic mallet.

Note: The wire is overgrown with grass and not visible after a few weeks.

3.7 To bury the boundary wire or the guide wire

- Cut a groove in the ground with an edge cutter or a straight shovel.
- Put the boundary wire or the guide wire 1-20 cm / 0.4-8 in. into the ground.

3.8 To extend the boundary wire or the guide wire

Note: Extend the boundary wire or the guide wire if it is too short for the work area. Use original spare parts, for example couplers.

1. Disconnect the charging station from the power outlet.
2. Cut the boundary wire or the guide wire with a pair of wire cutters where it is necessary to install the extension.
3. Add wire where it is necessary to install the extension.
4. Put the boundary wire or the guide wire into position.
5. Put the wire ends into a coupler.

Note: Make sure that you can see the ends of the boundary wire or the guide wire through the transparent area of the coupler.

6. Push down the cover on the coupler with adjustable pliers to attach the wires in the coupler.

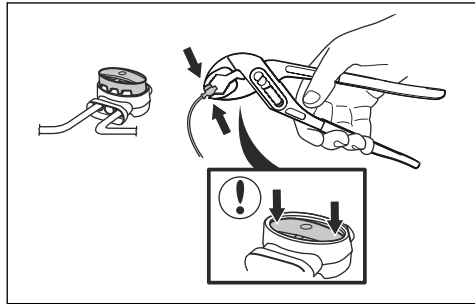

7. Put the boundary wire or the guide wire into position with stakes.
8. Connect the charging station to the power outlet.

3.9 After the installation of the product

3.9.1 To do a visual check of the charging station

1. Make sure that the indicator LED lamp on the charging station has a green light.

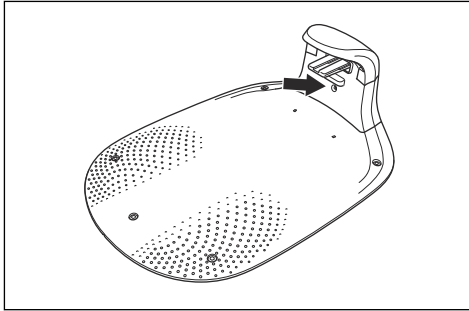

2. If the indicator LED lamp does not have a green light, do a check of the installation. Refer to *Indicator lamp in the charging station on page 40* and *To install the charging station on page 18*.

3.10 To download and pair with the GARDENA Bluetooth® app

Use the GARDENA Bluetooth® for the products that do not have the GARDENA smart system and the GARDENA smart Gateway. The GARDENA Bluetooth® app is a free app for your mobile device. The GARDENA Bluetooth® app is used for the settings and operation of the product. You can access the menus and functions when the product is connected to the app with Bluetooth®.

1. Download the GARDENA Bluetooth® app on your mobile device.
2. Push the **ON/OFF** button for 3 seconds to set the product to ON.
3. Enter the factory PIN code 1234 with the buttons on the product and push **OK** button. Refer to *PIN code on page 24*.

Note: We recommend you to change to a personal PIN code in the GARDENA Bluetooth® app.

4. Push the **Connectivity** button on the product to enable the pairing operation.

Note: The Bluetooth® pairing operation is enabled for 3 minutes.

5. Pair the GARDENA Bluetooth® app with the product.

3.11 To download and pair with the GARDENA smart system app

Use the GARDENA smart system app for the products that have the GARDENA smart system and the GARDENA smart Gateway to set settings and operation of the product.

1. Install the GARDENA smart system and connect it to the Internet.

Note: Read the instructions for the GARDENA smart system for more information about how to connect the GARDENA smart system.

2. Download the GARDENA smart system app on your mobile device.
3. Register as a user and log on to the app.
4. Select *Include product* in the app.
5. Select the product category *Robotic lawn mower*.
6. Push the **Connectivity** button on the product to enable the pairing operation mode.
7. Follow the instructions in the app.

3.11.1 To remove the product from the GARDENA smart system app

- Push the **Connectivity** button on the product for 3 seconds or select *Exclude the device* in the GARDENA smart system app.

4 Settings

Use the app for product settings. The factory settings are applicable for almost all work areas, but the settings can be adapted to the conditions for each work area.

4.1 To do the Schedule settings

The product has a maximum cutting time each day. You can set the operating time of the product in the schedule. The operating time includes cutting, searching and charging. The operating time can be different because of many reasons, for example the layout of the work area, the grass growth and age of the battery. When the product has operated to the maximum cutting time in a day, the message *Today's mowing complete* is shown in the display of the app.

You can set the schedule in 3 different procedures:

- Use the GARDENA assisted scheduling. Enter the dimension of your work area for the scheduling wizard to show an applicable schedule.
- Use the manual scheduling to set or adjust the schedule manually.
- Push the **Start** button and the **SpotCut** button at the same time to set a daily schedule. The daily schedule starts this current time each day and the product operates to its maximum cutting time each day. Refer to *To set the product to operate in Main area and make a daily schedule on page 25*.



CAUTION: Do not cut the lawn more than it is necessary to prevent wear on the product and the lawn.

4.2 Dynamic starting points

The product has *Dynamic starting points* that helps the product to select the most optimal operation and lawn coverage. This function is enabled from factory. If you want to do manual settings for your lawn or use the *CorridorCut*, disable the *Dynamic starting points* and the set *Starting points* manually.

4.2.1 Starting points and CorridorCut

If the work area includes remote parts that are connected with narrow passages, the *Starting points* and *CorridorCut* function are useful to be able to maintain a well-cut lawn in all parts of the yard. The *Starting points* function is used to guide the product to remote parts of the work area. The *CorridorCut* function is used for narrow passage mowing. A guide wire must be installed to use these functions. You can set a maximum of 3 remote areas.

With the *Starting points* function the product first follows and then leaves the guide wire after a certain distance and starts to mow the lawn.

Area A, approximately 50%

Area B, approximately 30%

Area C, approximately 20%

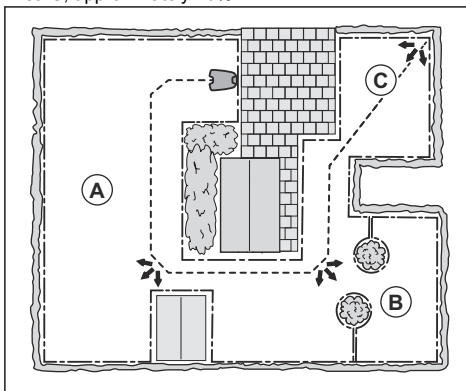

The *CorridorCut* function is suitable to mow narrow passages of 60 cm - 1.5 m / 2 ft. - 4.9 ft. width. The product moves in a pattern to cover the passage width. The product starts the *CorridorCut* at the set distance from the charging station. When the product reaches the end of the narrow passage, the product continues and cuts the lawn as normal.

Note: To prevent that the grass in the narrow passage is worn, GARDENA recommends to set a low percentage for the *CorridorCut*.

In the factory settings the product follows the guide wire 20% of the time for 99 m / 325 ft, or until the product reaches the connection with the boundary wire. The remaining time the product starts to cut at the starting point. In the factory settings the *CorridorCut* is disabled.

4.3 Drive Past Wire function

The front of the product always moves past the boundary wire by a specified distance. Then the product moves rearward and changes direction. The factory setting is 35 cm / 14 in. You can select a distance of 25-40 cm / 10-16 in.

Note: If you change the distance for *Drive Past Wire*, the distance will change along the boundary wire in all parts of the work area.

4.4 To set the charging station starting point

The product starts to operate at the starting point. The starting point is set to control how far the product

moves along the guide wire from the charging station. The product straddles the guide wire from the charging station to the starting point. The factory setting is 60 cm / 2 ft.

- Set the starting point at a short distance from the charging station to prevent tracks on the lawn.
- If the charging station is put in a small area, set the starting point (A) where the minimum distance (B) to the boundary wire is 60 cm / 2 ft.

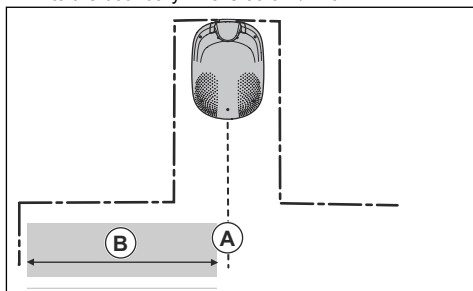

4.5 SensorControl



SensorControl automatically adjust the cutting time to the growth of the grass. The product is not permitted to operate more than the schedule settings. You can set how frequently the product cuts the grass when you use *SensorControl*. There are 3 frequency levels: *Low*, *Mid* and *High*. The higher the frequency, the more sensitive the product is to the grass growth. That is, if the grass growth is high then the product can operate longer.

Note: When using *SensorControl*, it is recommended to make as much operating time as possible available for *SensorControl*. Do not restrict the schedule more than necessary. Also, check that the blade disc is clean and that the blades are in good condition.

The first operation of the day is set by the schedule settings. The product always completes 1 mowing cycle, and then *SensorControl* selects if the product will continue to operate or not. In the factory setting this function is disabled.

Note: *SensorControl* is reset if the product does not operate for more than 50 hours, or if a *Reset of all user settings* is done. *SensorControl* is not changed if a *Reset of schedule settings* is done.

4.6 ECO mode

ECO mode disables the signal in the boundary wire, guide wire and the charging station, when the product is

parked or is charging. The LED indicator of the charging station flashes green when the loop signal is disabled.

Note: Use *ECO mode* to save energy and to prevent interference with other equipment, for example hearing loops or garage doors.

Note: To start the product manually in the work area you must first enable the loop signal.

4.6.1 To enable the loop signal

1. Set the product to ON.
2. Put the product in the charging station.
3. Push the **STOP** button.
4. Wait 2 seconds and then remove the product from the charging station.
5. Make sure that the LED indicator of the charging station is solid green.
6. Put the product where you want it to start to cut.

4.7 Trim-to-Edge

The *Trim-to-Edge* function makes it possible for the product to cut near the edges of the lawn. There are 2 settings that you can select for the product:

- *Along boundary wire* makes the product operate with the cutting pattern for the *Trim-to-Edge* function by the boundary wire.
- *On collision* makes the product operate with the cutting pattern for the *Trim-to-Edge* after collision with a tree or other object.

4.8 Frost Sensor

The grass is extra sensitive to wear if the yard is covered with frost. If the *Frost Sensor* is activated, the product is not allowed to start to cut the grass if the temperature is below 5° C / 41° F. In the factory setting this function is disabled.

Note: The frost sensor is located inside the chassis and there can be a delay compared to the ambient temperature.

4.9 ZoneProtect

If you install the GARDENA ZoneProtect accessory, you must enable the GARDENA ZoneProtect function to make the product sense the GARDENA ZoneProtect accessory.

4.10 New loop signal

The loop signal is manually selected to create a unique link between the product and the charging station. In rare cases, there may be a need to generate a new

signal, for instance if two adjacent installations have a very similar signal. Put the product in the charging station before you make a new loop signal.

4.11 PIN code

When you use the product for the first time you must enter the factory PIN code 1234. You can change the PIN code in the app. The PIN code must have 4 digits. You can use the numbers 1-4 to set a new PIN code.

4.12 Reset all user settings

Use this function to reset all user settings.

Note: *PIN code*, *Loop signal* and *Messages* are not reset when you select *Reset all user settings*.

5 Operation

5.1 To use the ON/OFF button



WARNING: Read and understand the safety chapter before you use the product.

- Push the **ON/OFF** button for 3 seconds to set the product to ON. Make sure that the LED indicator comes on.
- The product is ON and in power save mode if the LED indicator flashes. Push the **ON/OFF** button for 3 seconds to set the product to ON.

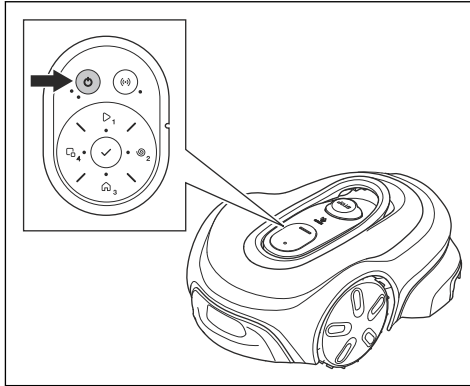

- Push the **ON/OFF** button for 3 seconds to set the product to OFF. Make sure that the LED indicator goes off.

Note: The product cannot be set to OFF when it is in the charging station.

5.1.1 The indicator lamp

The indicator lamps on the keypad show the operating modes of the product, refer to *LED status indicator on the keypad on page 9*.

5.2 To start the product

1. Push the **ON/OFF** button for 3 seconds.
2. Use the buttons on the keypad to enter the PIN code and then push the **OK** button. Refer to *PIN code on page 24*.
3. Select an operating mode. Refer to *Operating modes on page 25*.

Note: The first weeks after installation the perceived sound level when cutting the grass may be higher than expected. When the product has cut the grass for some time, the perceived sound level is much lower.

5.3 Operating modes

The following operating modes are available:

- *Main area*
- *Override schedule*
- *SpotCut*
- *Park / Schedule*
- *Park*
- *Secondary area*

5.3.1 Main area

Main area is the standard operating mode where the product mows and charges automatically.

5.3.1.1 To set the product to operate in Main area

This can be set in the dashboard in the app or with the keypad on the product:

1. Push the **STOP** button.
2. Push the **Start** button for 1 second.

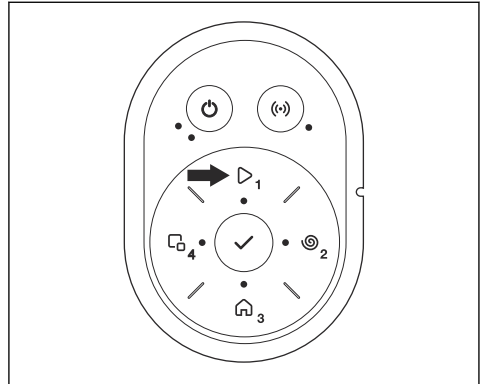

3. Push the **OK** button.

Note: If there is no set schedule a daily schedule will be set. The schedule will start at this current time each day and the product will operate to its maximum cutting time each day.

5.3.1.2 To set the product to operate in Main area and make a daily schedule

You can set a schedule that starts at this current time each day and cuts the maximum cutting time for the product each day. This can be set with the keypad on the product. The current set schedules will be deleted when this is selected.

1. Push the **STOP** button.
2. Push the **Start** button and the **SpotCut** button at the same time.

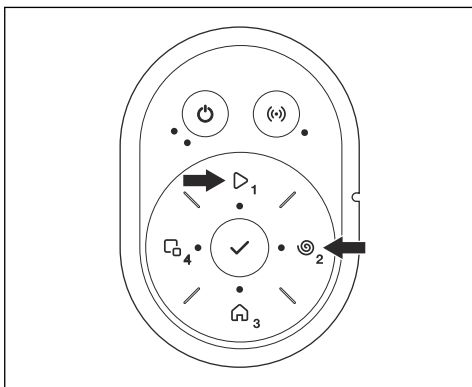

3. Push the **OK** button.

Note: This function is not available if your product is connected to the GARDENA smart Gateway.

5.3.2 Override schedule

Select *Override schedule* to temporarily override the schedule settings. You can select to override the schedule settings for 3 hours. The product cannot be set to cut more than the maximum cutting time for each day.

5.3.2.1 To override the schedule

This can be set in the dashboard in the app or with the keypad on the product:

1. Push the **STOP** button.
2. Push the **Start** button for 3 seconds.

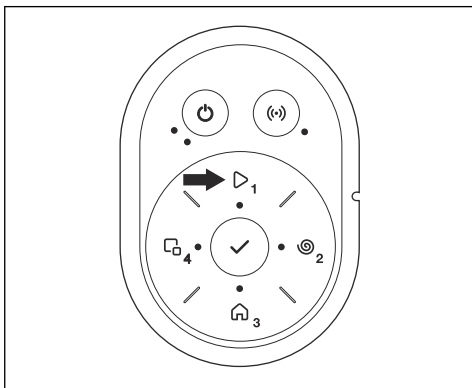

3. Push the **OK** button.

5.3.3 SpotCut

Use the *SpotCut* function to quickly cut an area where the grass has been cut less than in other parts of

the yard. You must manually move the product to the selected area.

SpotCut means that the product operates in a spiral pattern in order to cut the grass in the area where it was started. When this is done, the product automatically switches back to *Main area* or *Secondary area*.

5.3.3.1 To enable SpotCut

This can be set in the dashboard in the app or with the keypad on the product:

1. Push the **STOP** button.
2. Push the **SpotCut** button for 1 second.

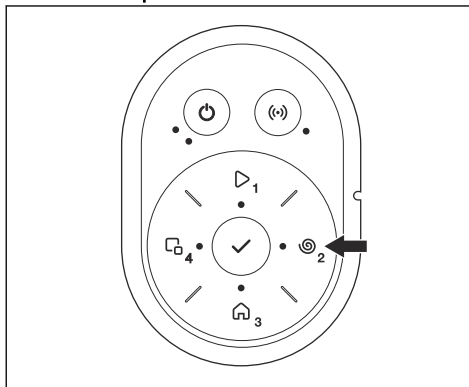

3. Push the **OK** button.

5.3.4 Park / Schedule

Operating mode *Park / Schedule* means that the product goes back to the charging station where it stays until the next schedule. If the product has operated the maximum cutting time for the day, it will start to operate again the next day. Refer to *To do the Schedule settings on page 22*.

5.3.4.1 To park the product and start again with the next schedule

This can be set in the dashboard in the app or with the keypad on the product:

1. Push the **STOP** button.
2. Push the **Park** button for 1 second.

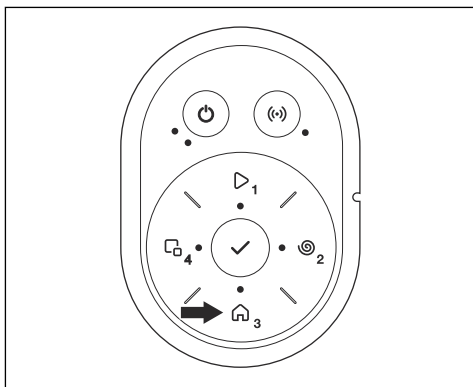

3. Push the **OK** button.

Note: To change the operating mode of the product, push the **STOP** button and the product will be in idle mode where you can set an operating mode.

5.3.5 Park

Operating mode *Park* means that the product returns to the charging station where it remains until a different operating mode is selected.

5.3.5.1 To park the product

This can be set in the dashboard in the app or with the keypad on the product:

1. Push the **STOP** button.
2. Push the **Park** button for 3 seconds.

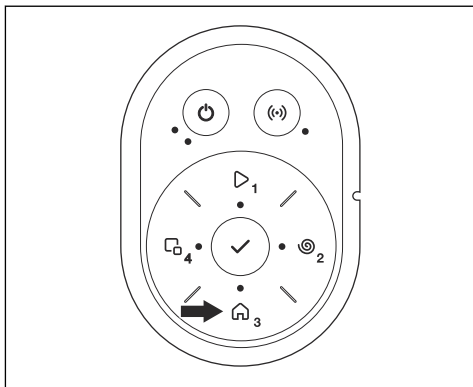

3. Push the **OK** button.

Note: To change the operating mode of the product, push the **STOP** button and the product will be in idle mode where you can set an operating mode.

5.3.6 Secondary area

To mow secondary areas the operating mode *Secondary area* must be selected. In this mode, the operator must move the product manually between the main area and the secondary area. The product mows until the battery is empty. When the battery is empty, put the product in the charging station to charge the battery. When the battery is charged, the product moves out of the charging station and stops. The product is now prepared to start operation, but needs confirmation from the operator first.

Note: Put the product in the charging station and change the operating mode to *Main area* in the app or with the keypad on the product if you want to cut the main area after the battery is charged.

5.3.6.1 To set the product to operate in Secondary area

This can be set in the dashboard in the app or with the keypad on the product:

1. Push the **STOP** button.
2. Push the **Secondary area** button for 1 second.

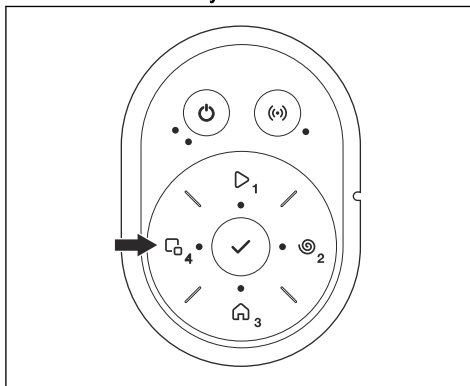

3. Push the **OK** button.

5.4 To stop the product

1. Push the **STOP** button on top of the product.

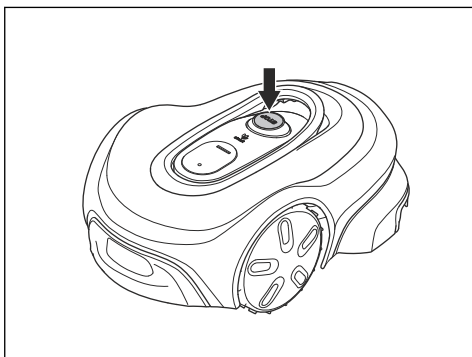

Note: When the **STOP** button is pushed the product will be idle. The product stops and the cutting motor stops.

5.5 To set the product to OFF

1. Push the **STOP** button.
2. Push the **ON/OFF** button for 3 seconds to set the product to OFF. Make sure that the LED indicator goes off.

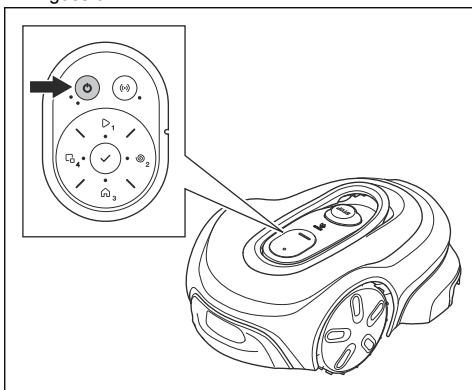

Note: The product cannot be set to OFF when it is in the charging station.

5.6 To charge the battery



WARNING: Only charge the product using a charging station which is intended for it. Incorrect use may result in electric shock, overheating or leakage of corrosive liquid from the battery.

In the event of leakage of electrolyte flush with water and seek medical help if it comes in contact with the eyes etc.

When the product is new or has been stored for a long period, the battery can be empty and needs to be charged before starting. In the *Main area* mode, the product automatically alternates between mowing and charging.

1. Push the **ON/OFF** button to start the product.
2. Put the product in as far as possible in the charging station. Make sure that the product and the charging station is connected. Refer to contact and charging strips in *Product overview on page 7*

5.7 Cutting height adjustment



CAUTION: The first weeks after a new installation, set the cutting height to 4 to prevent damage to the loop wire. You can then lower the cutting height each week.

You can select between 4 different cutting height steps. The blade disc has marks for each step. Step 1 is the lowest height and step 4 is the highest height. The factory setting is set to 4. For SILENO max you can set the cutting height on both discs.

5.7.1 To adjust the cutting height



WARNING: Use protective gloves.

1. Push the **STOP** button.
2. Push the **ON/OFF** button for 3 seconds to set the product to OFF. Make sure that the LED indicator goes out.
3. Put the product with the blade disc up on a soft and clean surface.
4. Remove the cover of the cutting height adjustment knob.

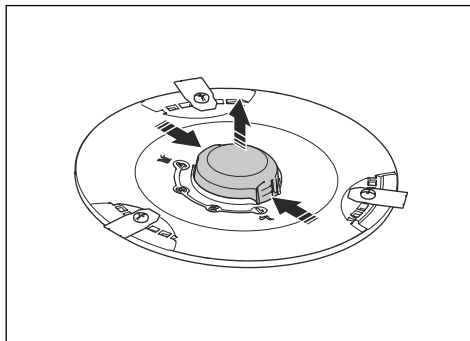

- 5. Push the cutting disc down and rotate the cutting height adjustment knob to select a cutting height.

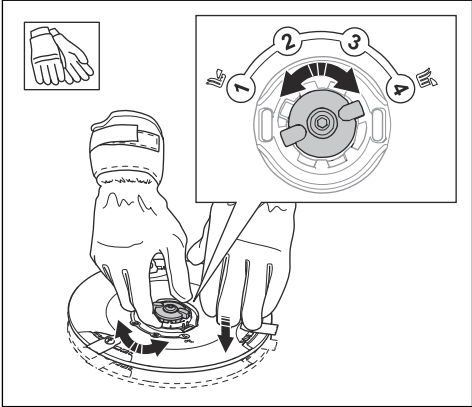

- 6. Release the cutting disc.
- 7. Attach the cover of the cutting height adjustment knob.

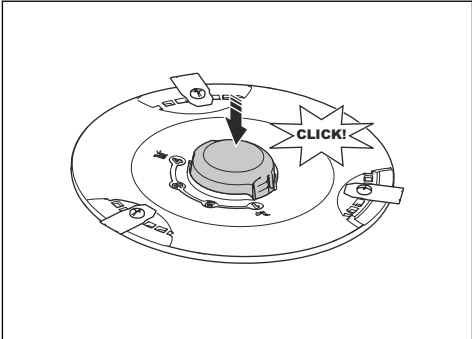

6 Maintenance

6.1 Introduction - maintenance



WARNING: Set the product to OFF before you do maintenance on the product.



WARNING: Use protective gloves.

For better operation and lifetime of the product, make sure to clean the product regularly and replace worn parts.

When the product is new, examine the blade discs and blades each week. If the wear is low, you can increase the interval for the next time you examine the blade discs and blades. Examine the blade discs and the blades more regularly if there is much wear.

It is important that the blade disc rotates easily and that the edges of the blades are not damaged. The usual lifetime of the blades are 4 to 7 weeks. The conditions that follow can increase or decrease the lifetime of the blades:

- Operation time and dimension of the work area.
- Length and thickness of the grass.
- Soil, sand and use of fertilizers.
- Objects such as cones, tools, stones and roots in the work area.

Note: The cutting result can be unsatisfactory if the blades are blunt. Refer to *Replacement of the blades on page 31* on how to replace the blades.

6.2 To remove the body of the product

1. Remove the top cover.

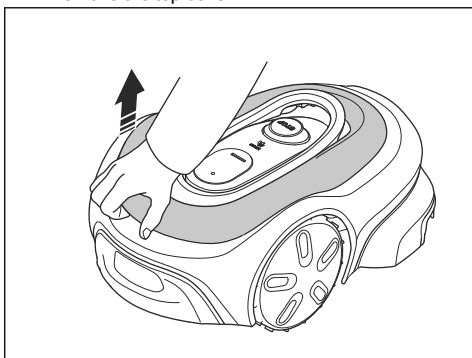

2. Push the clips that are on the rear side of the body of the product.

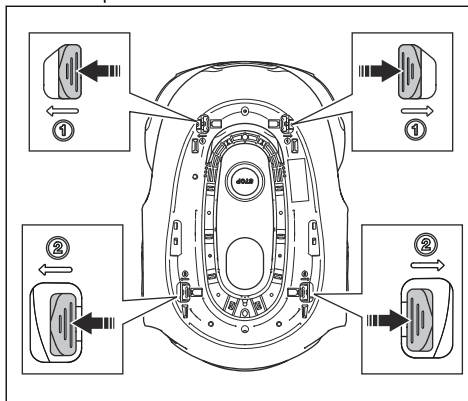

3. Push the clips that are on the front side of the body of the product.
4. Remove the body of the product from the chassis.

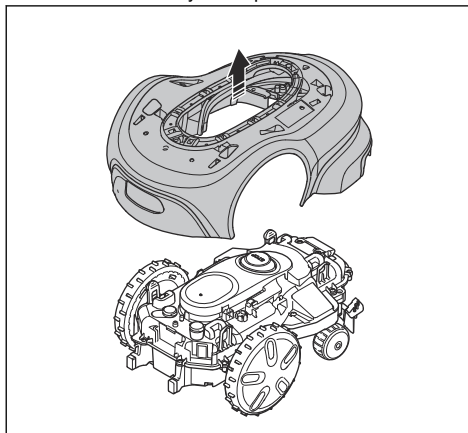

6.3 Clean the product



CAUTION: Do not use a high-pressure washer to clean the product. Do not use solvents for cleaning.

GARDENA recommends to use a special cleaning and maintenance kit. Speak to your GARDENA service for more information.

6.3.1 To clean the product

1. Remove the body of the product. Refer to *To remove the body of the product on page 30.*



CAUTION: Do not remove other parts from the product to clean it.

2. Clean the body of the product and the chassis with a brush and running water.
3. Install the body of the product and the top cover.

6.3.2 To clean the chassis and blade disc

Examine the blade discs and blades weekly.

1. Push the **STOP** button.
2. Push the **ON/OFF** button for 3 seconds to set the product to OFF. Make sure that the LED indicator on the keypad goes out.
3. Lift the product onto its side.
4. Make sure that the blades are not damaged and that the blades and blade discs can rotate freely.
5. Clean the blade discs and chassis with a brush and running water.

6.3.3 To clean the wheels

The product does not operate satisfactorily in slopes if the wheels are blocked with grass.

- Use a soft brush to clean the wheels.

6.3.4 To clean the body of the product

- Use a moist cloth and a weak soap solution to clean the body of the product.

6.3.5 To clean the charging plates and contact plates

1. Use a fine grade emery cloth to clean the charging plates and the contact plates.
2. Lubricate the charging plates and contact plates with oil or grease.

6.3.6 To clean the charging station



WARNING: Disconnect the power supply from the power outlet before maintenance, or when you clean the charging station or power supply.



CAUTION: Do not use a high-pressure washer or running water to clean the charging station.

Note: The product cannot enter the charging station if there are objects in the charging station. Clean the charging station regularly.

- Remove grass, twigs and other objects from the charging station.

6.4 Replacement of the blades



WARNING: GARDENA can only guarantee safety if you use GARDENA original blades with the embossed crowned H-mark logotype.

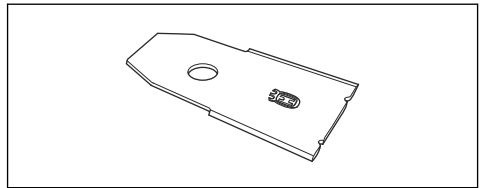

WARNING: You must replace the screws when you replace the blades. The used screws can wear quickly and make the blade come loose, this can cause serious injury.

Replace worn or damaged blades for a safe operation. Replace the blades regularly for a satisfactory cut result and a low energy use. All 3 blades and screws must be replaced at the same time to get a balanced cutting system.

6.4.1 To replace the blades

1. Push the **STOP** button.
2. Push the **ON/OFF** button for 3 seconds to set the product to OFF. Make sure that the LED indicator on the keypad goes out.

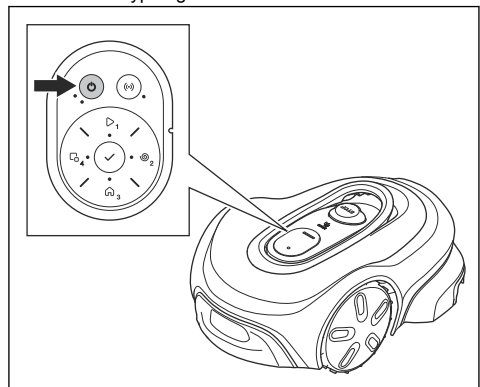

- Put the product with the blade disc up on a soft and clean surface.
- Remove the 3 screws and blades for each cutting disc.

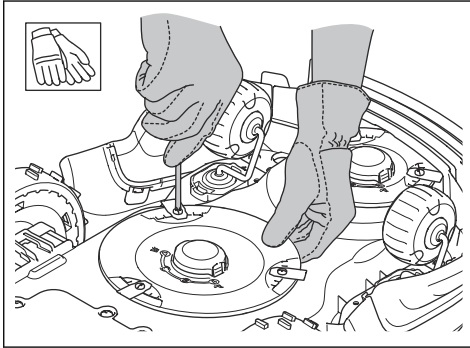

- Attach new blades and screws.
- Make sure that the blades can pivot freely.

6.5 Firmware update

GARDENA recommends the use of the apps to update the firmware. GARDENA regularly updates the firmware for the product. You can update the firmware of the product in 3 different procedures:

- With the GARDENA smart system app and the GARDENA smart Gateway.
- With the GARDENA Bluetooth® app with Wi-Fi Connection and firmware over the air (FOTA).
- Connect the product to your computer with a cable.

6.5.1 Firmware update with the GARDENA smart system app

When a new firmware is available, a notification shows in the app where you can select to install the new firmware.

6.5.2 Firmware update with the GARDENA Bluetooth® app

The product has a function that automatically downloads new firmware. The product downloads new firmware over the air (FOTA) when it is parked in the charging station and has Wi-Fi coverage. When a new firmware is available, a notification shows in the app where you can select to install the new firmware. Follow instructions in the GARDENA Bluetooth® app on how to connect the product to Wi-Fi.

6.5.3 To update the firmware with cable

- Remove the body of the product. Refer to *To remove the body of the product on page 30*.
- Push the clips on the HMI cover with a flat screwdriver.

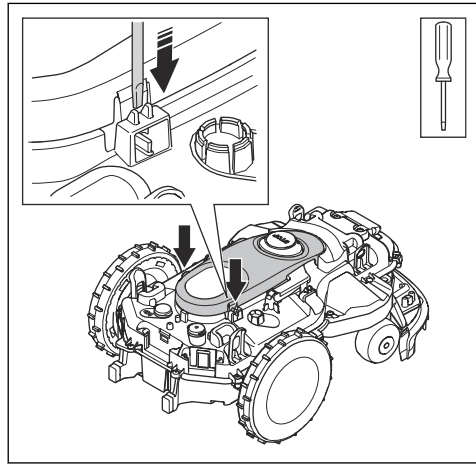

- Remove the HMI cover.

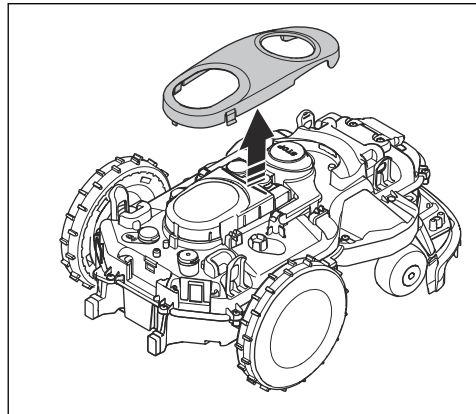

- Remove the USB cover with a flat screw driver.

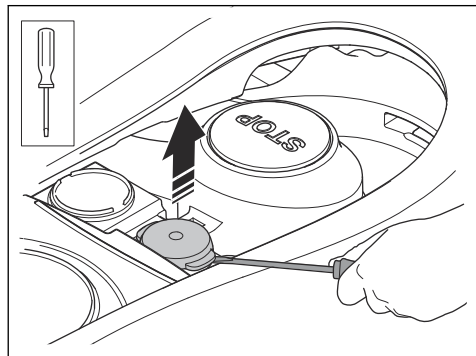

- Connect a USB-C cable to the product and your computer.

6. Go to www.gardena.com. Download the firmware update tool and follow the instructions.
7. Disconnect the cable.
8. Attach the cap and make sure that it seals fully.



CAUTION: Make sure that the cap seals fully to prevent moisture.

9. Install the body of the product and the top cover.

6.5.4 Update of the apps

The apps are regularly updated. Update the app on App Store or on Google Play to make sure that you have the latest version.

6.6 Battery



CAUTION: Charge the battery fully before you put the product into storage. If the battery is not fully charged it can cause damage to the battery.

If the operating time of the product is shorter than usual between charges, this means that the battery is at the end of its life cycle. Replace the battery to extend the operating time.

Note: The battery life is related to the length of the season and how many hours a day the product operates. A long season or many hours of operation a day means that the battery must be replaced more regularly.

6.6.1 To remove and install the battery



WARNING: Use protective gloves.



CAUTION: Do not touch the circuit boards.



CAUTION: If the battery housing is damaged, do not install or use the battery. Refer to *Disposal* on page 45.

1. Push the **ON/OFF** button for 3 seconds to set the product to OFF. Make sure that the LED indicator goes out.
2. Put the product with the blade disc up on a soft and clean surface.
3. Remove the 6 screws on the battery cover with a Torx 20 to remove the battery cover.

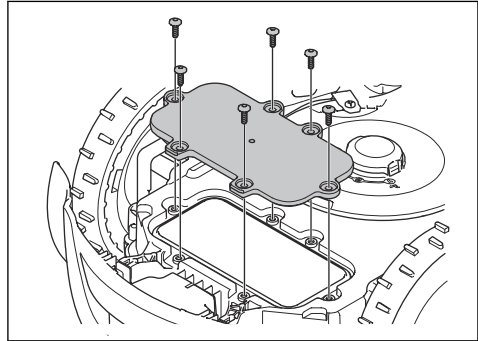

4. Push the clips that holds the battery and lift up the battery.

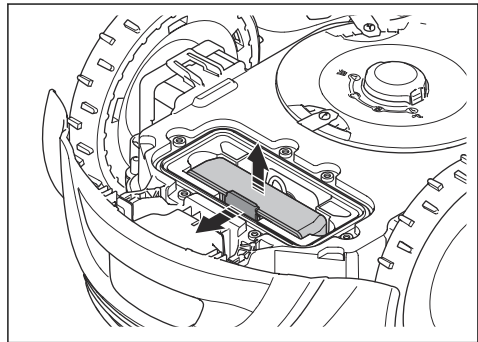

5. Disconnect the 2 cables from the battery.

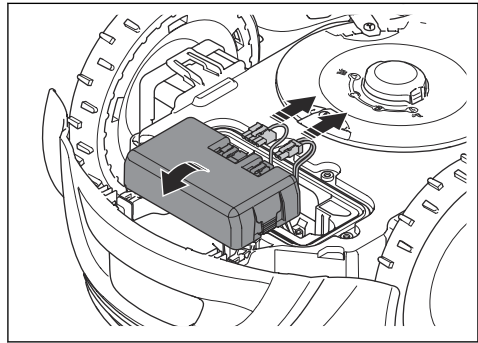

6. Remove the battery.
7. Install the battery in the opposite sequence.

6.7 Winter service

Take your product to your GARDENA service for service prior to winter storage. Regular winter service will maintain the product in good condition and create the best conditions for a new season without any disruptions.

Service usually includes the following:

- Thorough cleaning of the body, the chassis, the blade disc and all other moving parts.
- Testing of the product's function and components.
- Checking and, if required, replacing wear items such as blades and bearings.
- Testing the product's battery capacity as well as a recommendation to replace battery if necessary.
- If new firmware is available, the product is updated.

7 Troubleshooting

7.1 Messages

The messages in the table below are shown in the app. Speak to your GARDENA service if the same message shows frequently.

Message	Cause	Action
<i>Wheel motor blocked, left/right</i>	Grass or other object around the drive wheel.	Remove grass or other object.
<i>Cutting system blocked</i>	Grass or other object around the blade disc.	Remove grass or other object.
	The blade disc is in water.	Move the product and prevent the collection of water in the work area.
	The grass is too high.	Cut the grass before you install the product. Make sure that the grass is maximum 4 cm / 1.6 in.
<i>Trapped</i>	The product is behind a number of obstacles in a small area.	Remove the obstacles or put the boundary wire around the obstacle to make an island. Refer to <i>To make an island on page 15</i> .
<i>Outside work area</i>	A section of boundary wire is put across the other section of boundary wire to the charging station.	Make sure that the boundary wire is connected correctly.
	The boundary wire is too near the edge of the work area.	Make sure that the boundary wire is installed correctly. Refer to <i>Safety instructions for maintenance on page 4</i> .
	The work area slopes much by the boundary loop.	
	The boundary wire is put in the incorrect direction around an island.	
	Interference to the boundary wire from metal objects such as fences, reinforcement steel or buried cables nearby.	Move the boundary wire.
	The product can not find the correct loop signal because of interference with a loop signal from a different product installation nearby.	Put the product in the charging station and generate a new loop signal.

Message	Cause	Action
<i>Empty battery</i>	The product cannot find the charging station.	Change the position of the guide wire. Refer to <i>To install the guide wire on page 19</i> .
	The battery is at the end of its life cycle.	Replace the battery. Refer to <i>Battery on page 33</i> .
	The antenna of the charging station is damaged.	Do a check if the indicator lamp in the charging station flashes red. Refer to <i>Indicator lamp in the charging station on page 40</i> .
	The charging plates on the product or contact plates on the charging station is damaged because of corrosion.	Clean the charging plates and contact plates. Refer to <i>To clean the charging plates and contact plates on page 31</i> . If the problem stays speak to your GARDENA service.
<i>Slipped</i>	The product has got caught in something and has been slipping.	Free the product and correct the cause of problem. If it is because of wet grass, wait until the lawn is dry before you use the product.
	The work area includes a steep slope.	Steep slopes must be isolated. Refer to <i>To examine where to put the boundary wire on page 13</i> .
	The guide wire is not put diagonally in the slope.	Make sure that the guide wire is installed diagonally across the slope. Refer to <i>To examine where to put the guide wire on page 16</i> .
<i>Wheel motor overloaded, left/right</i>	Grass or other object around the drive wheel.	Remove grass or object from the drive wheel.
<i>Collision/Collision sensor problem</i>	The front wheels on the product are blocked.	Free the product and correct the cause of problem. If the problem stays speak to your GARDENA service.
<i>Charging station blocked</i>	The contact between the charging plates on the product and the contact plates on the charging station is not good. The product has made a number of tries to charge.	Put the product in the charging station and make sure that the charging plates and contact plates are connected.
	An object prevents the product to enter the charging station.	Remove the object.
	The charging station is tilted or bent.	Put the baseplate on level ground.
	The guide wire is not installed correctly.	Install the guide wire correctly. Refer to <i>To install the guide wire on page 19</i> .
<i>Stuck in charging station</i>	An object prevents the product to move out from the charging station.	Remove the object.
<i>Upside down</i>	The product is in an incorrect position, the product is tilting too much or is upside down.	Put the product in the correct position.

Message	Cause	Action
<i>Lifted</i>	The lift sensor has been enabled because the product has been lifted.	Make sure that the product body can move freely around its chassis. Remove or create an island around objects that can cause the chassis to be lifted. If the problem stays speak to your GARDENA service.
<i>Wheel drive problem, right/left</i>	Grass or other object around the drive wheel.	Clean the wheels and around the wheels.
<i>Electronic problem</i>	Temporary electronic or firmware related problem in the product.	Restart the product. If the problem stays speak to your GARDENA service.
<i>Loop sensor problem, front/rear</i>		
<i>Tilt sensor problem</i>		
<i>Temporary problem</i>		
<i>Invalid sub-device combination</i>		
<i>Temporary battery problem</i>		
<i>Safety function faulty</i>		
<i>STOP button problem</i>		
<i>Invalid system configuration</i>		
<i>Lift sensor problem</i>		
<i>Charging system problem</i>	There is corrosion or dirt on the charging plates and contact plates.	Restart the product. Clean the charging plates on the product and the contact plates on the charging station.
	Temporary electronic or firmware problem in the product.	Restart the product. If the problem stays, speak to your approved servicing dealer.
<i>Battery problem</i>	Temporary battery or firmware related problem in the product.	Restart the product. If the problem stays speak to your GARDENA service.
	Incorrect type of battery.	Use original batteries recommended by the manufacturer.
<i>Battery temperature outside limits</i>	The temperature in the battery is too high or too low to start operation.	The temperature in the battery is not in its operating limits and charging/mowing has stopped. Charging/mowing will start when the temperature is restored to its limits.
<i>Charging current too high</i>	Incorrect or damaged power supply unit.	Restart the product. If the problem stays speak to your GARDENA service.

Message	Cause	Action
<i>No loop signal</i>	The power supply or low-voltage cable are not connected.	If the LED status indicator on the charging station is not lit, it shows that there is no power. Examine the power outlet connection and the residual-current device. Make sure that the low-voltage cable is connected to the charging station.
	The power supply or low-voltage cable are damaged or not connected.	Replace the power supply or low-voltage cable.
	The boundary wire is not connected to the charging station.	Connect the boundary wire to the charging station. Replace the connectors if damaged. Refer to <i>To install the boundary wire on page 19</i> .
	The boundary wire is damaged.	Do a check of the LED status indicator on the charging station. If it shows damage in the boundary wire, replace the damaged section with new boundary wire.
	The product has tried to start but it is not in the charging station and <i>ECO mode</i> is enabled.	Put the product in the charging station and start the product.
	A section of the boundary wire is across the other section of boundary wire to and from an island.	Install the boundary wire in the correct direction around the island. Refer to <i>To install the boundary wire on page 19</i> .
	Problem with the pairing between the product and the charging station.	Put the product in the charging station and make a new loop signal. Refer to <i>New loop signal on page 23</i> .
	Interference from metal objects such as fences, reinforcement steel or buried cables nearby.	Move the boundary wire and/or make islands in the work area to increase the signal strength.
The product is too far from the boundary wire.	Install the boundary wire to make all parts of the work area maximum 15 m / 50 ft. from the boundary wire.	
<i>Mower tilted</i>	The product is tilted more than the maximum angle.	Move the product to a level area.
<i>Guide not found</i>	The guide wire is not connected to the charging station.	Connect the guide wire to the charging station. Refer to <i>To install the guide wire on page 19</i> .
	Damage in the guide wire.	Replace the damaged section with new guide wire.
	The guide wire is not connected to the boundary loop.	Connect the guide wire correctly to the boundary loop. Refer to <i>To install the guide wire on page 19</i> .
<i>Connection NOT changed</i>	The loop signal was not changed because of an error.	Make a <i>New loop signal</i> a number of times. Refer to <i>New loop signal on page 23</i> . If the problem stays speak to your GARDENA service.

Message	Cause	Action
<i>Slope too steep</i>	The product stopped because the slope is too steep.	Change the installation of the boundary wire to exclude this steep part of the work area. Refer to <i>To install the boundary wire on page 19</i> .
<i>Cutting system imbalance</i>	The product has senses vibrations in the blade disc.	Examine that the blades and screws are not damaged or worn. Make sure that all blades are correctly installed and that there is only one blade attached in each position on the blade disc.
<i>No power in charging station</i>	The power supply unit is incorrect or damaged.	Examine the power supply unit. Replace the power supply unit if it is necessary.
	Power failure.	Find and correct the cause of the power failure.
	The product cannot charge because there is no contact between the contact plates and the charging plates.	Make sure that the charging plates and the contact plates are in contact. Clean the charging plates and the contact plates.
<i>Destination not reachable</i>	The product cannot reach the destination because there is no guide wire or boundary wire within the work area.	Edit or make a new installation of the work area in the app and include a guide or a boundary wire in the work area.
	The product cannot reach the destination because there is a stay-out blocking the way to the work area.	Edit or remove the stay-out zone or make a new installation of the work area.
<i>Destination blocked</i>	The way of the destination is blocked by an obstacle.	Remove the obstacle that blocks the way to the destination.
<i>Battery needs replacement</i>	The battery state of health is low.	Replace the battery. Speak to your authorized service technician.
<i>Battery near end of life</i>	The battery state of health is critically low.	Replace the battery. Speak to your authorized service technician.
<i>Invalid firmware configuration</i>	The firmware in the product is invalid.	Put the product in the charging station and update the firmware via FOTA. If the problem remains, speak to your authorized service technician.
<i>Zone generator problem</i>	The battery of the ZoneProtect accessory is low. The ZoneProtect accessory does not operate when the battery is empty. The product can cut in the stay-out zone if you start the product before you charge the ZoneProtect accessory.	Park the product and charge the ZoneProtect accessory before you start the product.
	The temperature in the ZoneProtect accessory is a higher than the maximum limit and is set to off.	Put the product in an area with protection from the sun. Let the temperature of the ZoneProtect accessory decrease before you start the product.
<i>Edge cutting disc blocked</i>	The edge cutting system is blocked by grass or other objects.	Examine the edge cutting system and remove the grass or other objects.

Message	Cause	Action
<i>Imbalanced edge cutting disc</i>	The product has senses vibrations in the edge blade disc.	Examine that the blades and screws are not damaged or worn. Make sure that all blades are correctly installed and that there is only one blade attached in each position on the blade disc.

7.2 Indicator lamp in the charging station

The indicator lamp in the charging station must show a solid or flashing green light for a correct installation. If not, follow the instructions in the troubleshooting table below.

Speak to your GARDENA service for more information.

Light	Cause	Action
Green solid light	Good signals.	Usual operation of the product.
Green flashing light	The signals are good and <i>ECO mode</i> is enabled.	Usual operation of the product. Refer to <i>ECO mode on page 23</i> .
Blue flashing light	The boundary wire is not connected to the charging station.	Make sure that the boundary wire is correctly installed in the charging station. Refer to <i>To install the boundary wire on page 19</i> .
	Damage in the boundary wire.	Find out where the damage is. Replace the damaged section with new boundary wire.
Red flashing light	Interference in the antenna of the charging station.	Speak to your GARDENA service.
Red solid light	Error in the circuit board or incorrect power supply in the charging station. The error must be corrected by your GARDENA service	Speak to your GARDENA service.

7.3 Symptoms

If the product does not operate as usual, follow the symptoms table below. Speak to your GARDENA service if you cannot find the cause for the fault.

Symptoms	Cause	Action
The product has difficulty docking.	The guide wire is not put straight in a line and correct distance from the charging station.	Do a check of the installation of the charging station. Refer to <i>To install the charging station on page 18</i> .
	The guide wire is not put in the slot in the charging station plate.	Make sure that the guide wire is put straight in a line and put in the slot in the charging station plate. Refer to <i>To install the guide wire on page 19</i> .
	The charging station is not on a level surface.	Put the charging station on a level surface. Refer to <i>To examine where to put the charging station on page 12</i> .
The product operates at the wrong time.	The start and stop times for operating are incorrect.	Change the schedule settings. Refer to <i>To do the Schedule settings on page 22</i> .
The product vibrates.	The cutting system is not in balance because of damaged blades.	Examine the blades and screws and replace them if necessary. Refer to <i>Replacement of the blades on page 31</i> .
	The cutting system is not in balance because of too many blades in the same position.	Do a check that only one blade is attached to each screw.
	Different thickness of blades are installed on the product.	Do a check if the blades are of different thickness and replace if necessary.
The product operates, but the blade disc does not rotate.	The product searches for the charging station, or is moving to the starting point.	Usual operation for the product. The blade disc does not rotate when the product is searching for the charging station.
The product operates for shorter periods than usual between charges.	Grass or other object causes a blockage to the blade disc.	Remove and clean the blade disc. Refer to <i>To clean the chassis and blade disc on page 31</i> .
	The battery is at the end of its life cycle.	Replace the battery. Refer to <i>Battery on page 33</i> .
	Blunt blades. More energy is necessary when cutting the grass.	Replace the blades. Refer to <i>Replacement of the blades on page 31</i> .
Mowing and charging times are shorter than usual.	The battery is at the end of its life cycle.	Replace the battery. Refer to <i>Battery on page 33</i> .
The product is parked for hours in the charging station.	The product has operated the maximum cutting time for the day.	Usual operation for the product. Refer to <i>To do the Schedule settings on page 22</i> .
	The STOP button has been pushed.	Enter the PIN code and push the OK button. Push the Start button.
	Parking mode is enabled.	Change the operating mode. Refer to <i>Operating modes on page 25</i> .
	The product does not operate if the battery temperature is too high or too low.	Make sure that the charging station is put in an area with protection from the sun.

Symptoms	Cause	Action
Uneven mowing results.	The product operates for a small number of hours per day.	Increase the cutting time. Refer to <i>To do the Schedule settings on page 22</i> .
	For the shape of the work area it is necessary to adjust the settings for <i>Starting points</i> to cover all parts of the work area.	Change the settings of the areas where the product starts to cut and how often. Refer to <i>Starting points and CorridorCut on page 22</i> .
	The work area is too large.	Decrease the size of the work area or extend the schedule. Refer to <i>To do the Schedule settings on page 22</i> .
	Blunt blades.	Replace all the blades. Refer to <i>Replacement of the blades on page 31</i> .
	Long grass in relation to the set cutting height.	Increase the cutting height and then lower it when the grass is shorter.
	Collection of grass by the blade disc or around the motor shaft.	Remove the collection of grass and clean the product. Refer to <i>Clean the product on page 30</i> .
The battery state of charge is high, but the product goes back to the charging station.	To prevent to become blocked in a small area, the product follows the guide wire to the charging station.	Usual operation for the product.

7.4 Find breaks in the loop wire

Breaks in the loop wire are usually the result of unintentional physical damage to the wire such as when gardening with a shovel. In countries with ground frost, also sharp stones that move in the ground can damage the wire. Breaks can also occur due to the wire being stretched excessively during installation.

Mowing the grass too low right after the installation can damage wire insulation. Damage to the insulation may not cause disruptions until several weeks or months later. To avoid this, always select the maximum cutting height the first weeks after installation and then lower the height one step at a time every second week until the desired cutting height has been reached.

A damaged splicing of the loop wire can also lead to disruptions several weeks after the splice was done. A faulty splice can, for example, be the result of the coupler not being pressed together hard enough with a pair of pliers, or that a coupler of lower quality than the original coupler has been used. Please first check all known splices before further troubleshooting is done.

A wire break can be located by gradually halving the distance of the loop where the break may have occurred until there is only a very short section of the wire left.

The following method does not work if *ECO mode* is activated. Make sure first that *ECO mode* is switched off. Refer to *ECO mode on page 23*.

1. Check that the indicator lamp in the charging station flashes blue, which indicates a break in

the boundary loop. Refer to *Indicator lamp in the charging station on page 40*.

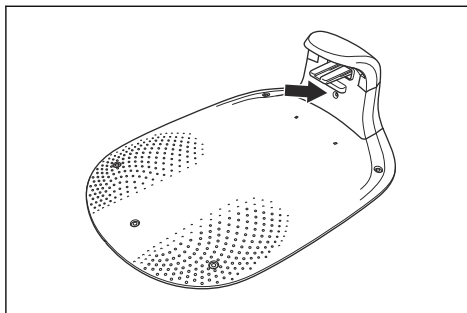

2. Check that the boundary wire connections to the charging station are properly connected and not damaged. Check that the indicator lamp in the charging station is still flashing blue.

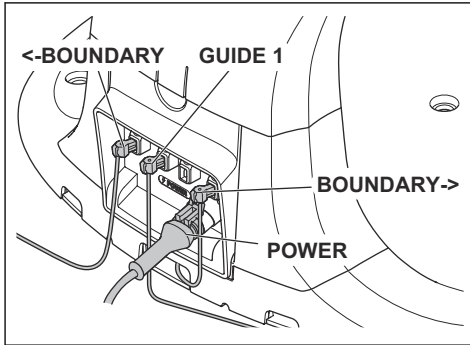

3. Switch the connections between the guide wire and the boundary wire in the charging station.

Start by switching connection BOUNDARY-> and GUIDE.

If the indicator lamp is flashing yellow, then the break is somewhere on the boundary wire between BOUNDARY-> and the point where the guide wire is connected to the boundary wire (thick black line in the illustration).

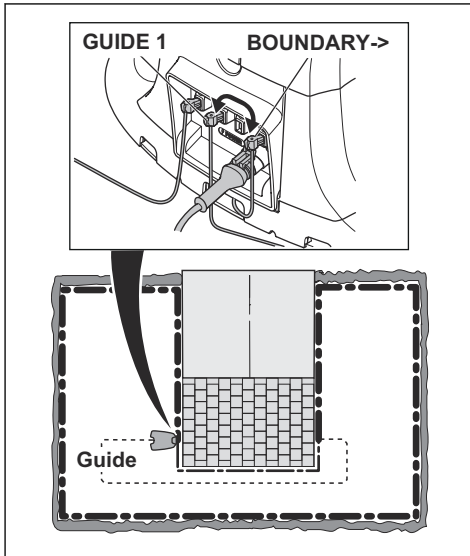

To rectify the fault you will need boundary wire, connector(s) and coupler(s):

- a) If the suspected boundary wire is short then the easiest way is to exchange all of the boundary wire between BOUNDARY-> and the point where the guide wire is connected to the boundary wire (thick black line).

- b) If the suspected boundary wire is long (thick black line) then do as follows: Put BOUNDARY-> and GUIDE back to their original positions. Then disconnect <-BOUNDARY. Connect a new loop wire to <-BOUNDARY. Connect the other end of this new loop wire at the middle of the suspected wire section.

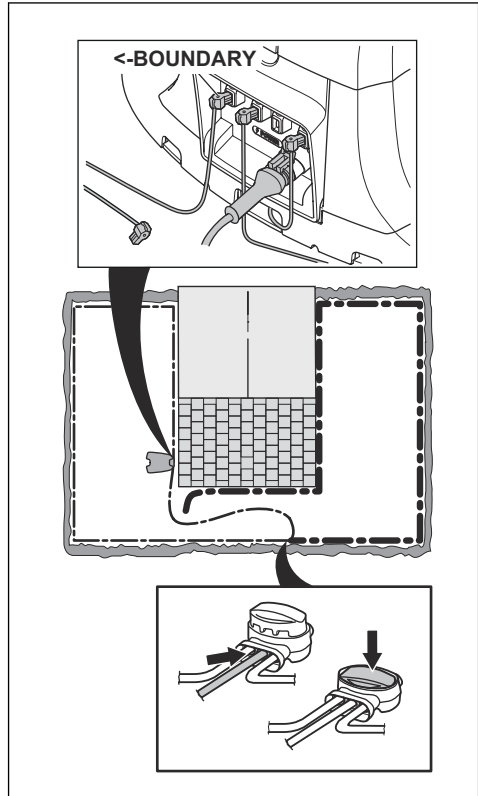

- If the indicator lamp now is flashing yellow, then the break is somewhere in the wire between the disconnected end to the point where the new wire is connected (thick black line below). In that case, move the connection for the new wire closer to the disconnected end (roughly at the middle of the suspected wire section) and check again if the indicator lamp is green.

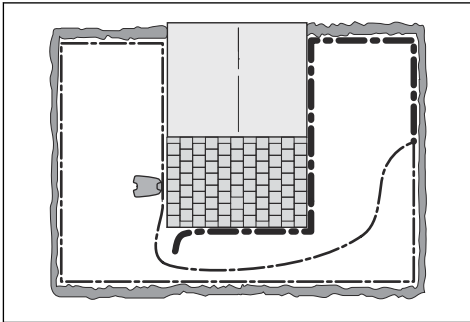

Continue until only a very short section of the wire remains which is the difference between a solid green light and a flashing blue light. Then follow instruction in step 5 below.

4. If indicator lamp still flashes blue in step 3 above: Put BOUNDARY-> and GUIDE back in their original positions. Then switch <-BOUNDARY and GUIDE. If indicator lamp now is lit with a solid green light then disconnect BOUNDARY-> and connect a new boundary wire to BOUNDARY->. Connect the other end of this new wire at the middle of the suspected wire section. Follow the same approach as in 3a) and 3b) above.
5. When the break is found, the damaged section must be replaced with a new wire. Always use original couplers.

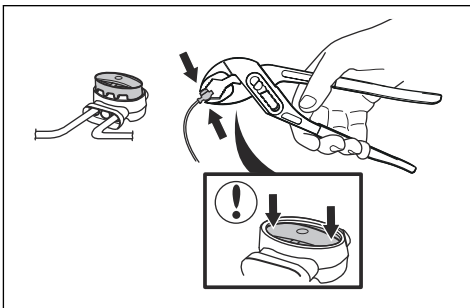

8 Transportation, storage and disposal

8.1 Transportation

The supplied Li-ion batteries obey the Dangerous Goods Legislation requirements.

- Obey all applicable national regulations.
- Obey the special requirement on package and labels for commercial transportations, including by third parties and forwarding agents.

8.2 Storage

- Fully charge the product. Refer to *To charge the battery on page 28*.
- Set the product to OFF. Refer to *To set the product to OFF on page 28*.
- Clean the product. Refer to *Clean the product on page 30*.
- Keep the product in a dry, frost free space.
- Keep the product with all wheels on level ground.
- If you keep the charging station indoors, disconnect and remove the power supply and all the connectors from the charging station. Put the end of each connector wire in a connector protection box.

Note: If you keep the charging station outdoors, do not disconnect the power supply and the connectors.

- Speak to your GARDENA service for information about available storage accessories for your product.

8.3 Disposal

- Obey the local recycling requirements and applicable regulations.
- For questions about how to remove the battery, refer to *Battery on page 33*.

9 Technical data

9.1 Technical data

Dimensions	SILENO pro	SILENO max
Length, cm	60	63
Width, cm	41	43
Height, cm	26	26
Weight, kg	8.6	10.3

Electrical system	SILENO pro	SILENO max <1100 m ²	SILENO max ≥1100 m ²
Battery, Lithium-Ion 18.0 V/2.0 Ah Art.No	5937420-03, 5937420-04, 5937420-05		
Power supply (28V DC), V AC	100-240		
Low-voltage cable length, m	3		
Mean energy consumption at maximum use	6 kWh/month in a 600 m ² work area	8 kWh/month in a 1000 m ² work area	10 kWh/month in a 1500 m ² work area
Charge current, A DC	1/1.3		2.2
Type of Power Supply Unit ⁶	ADP-40KR XX		FW7438/28/D/XX/Y
Average mowing time, min	50		
Average charging time, min	90/70		40

Boundary wire antenna	SILENO pro/max
Operating Frequency Band, Hz	100-80000
Maximum magnetic field ⁷ , dBuA/m	82
Maximum Radio-frequency power ⁸ , mW @60m	<25

Sound data ⁹	SILENO pro	SILENO max
Sound level, perceived, dB (A)	57	58
Measured sound power noise level, dB (A)	56	57
Noise emissions uncertainties K _{WA} , dB (A)	1	5
Sound pressure noise level at the operator's ear ¹⁰ , dB (A)	48	49

⁶ XX, YY can be any alphanumeric characters or blank for marketing purpose only, no technical differences.

⁷ Measured according to EN 303 447.

⁸ Maximum active output power to antennas in the frequency band in which the radio equipment operates.

⁹ Determined according to Directive 2006/42/EC and standard EN 50636-2-107. Except Sound level, perceived that is measured according to ISO 11094:1991.

¹⁰ Sound pressure noise uncertainties K_{pA}, 2-4 dB (A)

Mowing	SILENO pro	SILENO max
Cutting system	3 pivoted cutting blades	2 discs with 3 pivoting blades
Cutting motor speed, rpm	2670	2670 for edge disc / 2300 for main disc
Power consumption during cutting, W +/- 20 %	23	25
Cutting height, cm	2.5-4.5	
Cutting width, cm	16	22
Narrowest possible passage, cm	60	
Maximum slope for work area, %	25	35
Maximum slope for boundary wire, %	15	
Maximum length boundary wire, m	300 / 980	
Maximum length guide loop ¹¹ , m	150 / 490	

IP-code	SILENO pro/max
Product	IPX5
Charging station	IPX5
Power supply	IP44

Bluetooth®	SILENO pro/max
Operating frequency band, MHz	2400 - 2484
Maximum transmitted power, dBm	8

Internal SRD (short range device)	
Operating frequency band, MHz	863-870
Maximum transmitted power, dBm	14
Free field radio range, approx. m	100

Husqvarna AB does not guarantee full compatibility between the product and other types of wireless systems such as remote controls, radio transmitters, hearing loops, underground electric animal fencing or similar.

The products are made in England or the Czech Republic. See information on the rating plate. Refer to *Introduction on page 6*.

9.2 Registered trademarks

The *Bluetooth®* word mark and logos are registered trademarks owned by *Bluetooth SIG, inc.* and any use of such marks by GARDENA is under license.

App Store is a trademark of Apple Inc.

Google Play is a trademark of Google LLC.

¹¹ The guide loop is the loop that if formed by the guide wire and the part of the boundary wire from the junction with the guide wire to the right connection in the charging station.

10 Declaration of Conformity

10.1 Original EU Declaration of Conformity

EU Declaration of Conformity

ROB-P14G-24-2E

We, Husqvarna AB, SE 561 82 Huskvarna, SWEDEN, Tel. +46 36 146500 declare on our sole responsibility that the product:

Description	Robotic lawn mower
Brand	GARDENA
Type / Model	GARDENA SILENO pro, smart SILENO pro, SILENO max and smart SILENO max
Identification	Serial numbers dating from 2024 week 28

complies fully with the following EU directives and regulations:

Directive/Regulation	Description
2006/42/EC	"relating to machinery"
2014/53/EU	"relating to radio equipment"
2011/65/EU	"restriction of use of certain hazardous substances"

and that the following standards and/or technical specifications are applied;

EN 60335-1:2012+AC:2014+A11:2014+A13:2017+A15:2021

EN 50636-2-107:2015+A1:2018+A2:2020+A3:2021

EN IEC 63000:2018

EN 55014-1:2017+A11:2020

EN 55014-2:1997+A1:2001+A2:2008+AC:1997

ETSI EN 301 489-1 V1.9.2

ETSI EN 301 489-3 V2.3.2

ETSI EN 301 489-17 V3.2.4

ETSI EN 303 447 V1.3.1

ETSI EN 300 328 V2.2.2

ETSI EN 303 413 V1.2.1

and for the models equipped with radar accessory the following additional standards apply:

Draft ETSI EN 305 550 V2.1.0

ETSI EN 305 550-1 v1.2.1

ETSI EN 305 550-2 v1.2.1

and for the smart SILENO pro and smart SILENO max the following additional standards apply:

ETSI EN 301 489-19 V2.2.1

ETSI EN 300 220-1 V3.1.1

ETSI EN 300 220-2 V3.1.1

ETSI EN 303 413 V1.2.1

Lars Roos (Jun 13, 2024 12:52 GMT+2)

Lars Roos
Huskvarna

R&D Director, Robotics & Smart Business Unit
Husqvarna AB, Gardena Division
Responsible for technical documentation



10.2 Translated EU Declaration of Conformity

We, Husqvarna AB, SE-561 82 Huskvarna, SWEDEN,
Tel: +46 36 146500 declare on our sole responsibility
that the product:

Description	Robotic lawn mower
Brand	GARDENA
Type/Model	GARDENA SILENO pro, smart SILENO pro, SILENO max and smart SILENO max
Identification	Serial numbers dating from 2024 week 28

complies fully with the following EU directives and regulations:

Directive/Regulation	Description
2006/42/EC	"Relating to machinery"
2014/53/EU	"Relating to radio equipment"
2011/65/EU	"Restriction of use of certain hazardous substances"

and that the following harmonized standards and/or technical specifications are applied;

- EN 60335-1:2012+AC:2014+A11:2014+A13:2017+A15:2021
- EN 50636-2-107:2015+A1:2018+A2:2020+A3:2021
- EN IEC 63000:2018
- EN 55014-1:2017+A11:2020
- EN 55014-2:1997+A1:2001+A2:2008+AC:1997
- ETSI EN 301 489-1 V1.9.2
- ETSI EN 301 489-3 V2.3.2
- ETSI EN 301 489-17 V3.2.4
- ETSI EN 303 447 V1.3.1
- ETSI EN 300 328 V2.2.2
- ETSI EN 303 413 V1.2.1

and for the models equipped with radar accessory the following additional standards apply:

- Draft ETSI EN 305 550 V2.1.0
- ETSI EN 305 550-1 v1.2.1
- ETSI EN 305 550-2 v1.2.1

and for the smart SILENO pro and smart SILENO max the following additional standards apply:

- ETSI EN 301 489-19 V2.2.1
- ETSI EN 300 220-1 V3.1.1
- ETSI EN 300 220-2 V3.1.1
- ETSI EN 303 413 V1.2.1

Lars Roos
Huskvarna

R&D Director, Robotics & Smart Business Unit.
Husqvarna AB, Gardena Division. Responsible for
technical documentation.



11 Applicable to UK market

11.1 Original UK Declaration of Conformity

Declaration of Conformity

ROB-P14G-24-2U

We, Husqvarna AB, SE 561 82 Huskvarna, SWEDEN, Tel. +46 36 146500 declare on our sole responsibility that the product:

Description	Robotic lawn mower
Brand	GARDENA
Type / Model	GARDENA SILENO pro, smart SILENO pro, SILENO max and smart SILENO max
Identification	Serial numbers dating from 2024 week 28

complies fully with the following UK regulations:

Regulation	Description
S.I. 2008/1597	The Supply of Machinery (Safety) Regulations 2008
S.I. 2017/1206	The Radio Equipment Regulations 2017
S.I. 2012/3032	The Restriction of the Use of Certain Hazardous Substances in Electrical and Electronic Equipment Regulations 2012

and that the following standards and/or technical specifications are applied;

EN 60335-1:2012+AC:2014+A11:2014+A13:2017+A15:2021

EN 50636-2-107:2015+A1:2018+A2:2020+A3:2021

EN IEC 63000:2018

EN 55014-1:2017+A11:2020

EN 55014-2:1997+A1:2001+A2:2008+AC:1997

ETSI EN 301 489-1 V1.9.2

ETSI EN 301 489-3 V2.3.2

ETSI EN 301 489-17 V3.2.4

ETSI EN 303 447 V1.3.1

ETSI EN 300 328 V2.2.2

ETSI EN 303 413 V1.2.1

and for the models equipped with radar accessory the following additional standards apply:

Draft ETSI EN 305 550 V2.1.0

ETSI EN 305 550-1 v1.2.1

ETSI EN 305 550-2 v1.2.1

and for the smart SILENO pro and smart SILENO max the following additional standards apply:

ETSI EN 301 489-19 V2.2.1

ETSI EN 300 220-1 V3.1.1

ETSI EN 300 220-2 V3.1.1

ETSI EN 303 413 V1.2.1

[Lars Roos \(Jun 13, 2024 12:53 GMT+2\)](#)

Lars Roos
Huskvarna



UK Importer:
Husqvarna UK Ltd
Preston Road, Co. Durham
DL5 6UP

R&D Director, Robotics & Smart Business Unit
Husqvarna AB, Gardena Division
Responsible for technical documentation

11.2 Statement of compliance

Statement of compliance

PSTI-ROB-GardenaP14-24-1U

We, Husqvarna AB, SE 561 82 Huskvarna, SWEDEN, Tel. +46 36 146500 declare on our sole responsibility that the product:

Description	Robotic lawn mower
Brand	Gardena
Type / Model	Gardena SILENO pro, SILENO max, SILENO free
Identification	Serial numbers dating from 2024 week 40
Support period	At least 3 years from the manufacturing date.

complies fully with the following UK regulations:

Description
The Product Security and Telecommunications Infrastructure (Security Requirements for Relevant Connectable Products) Regulations 2023, Schedule 2.
ETSI EN 303 645 V2.1.1 (2020-06)

UK Importer:
Husqvarna UK Ltd
Preston Road, Co. Durham
DL5 6UP

[Lars Roos \(Jun 27, 2024 12:34 GMT+2\)](#)

Lars Roos

Director R&D Robotics & Smart Business Unit
Husqvarna AB, Gardena Division
Responsible for technical documentation



ORIGINAL INSTRUCTIONS

We reserve the right to make changes without prior notice.
Copyright © 2024 GARDENA Manufacturing GmbH. All rights reserved.

1144035-26



2024-09-12