**Art. 20505-81****Operator's manual**
Retractable Hose Reel**Customer Service:****Important!**

Before returning to the place of purchase, please contact us first. We will do our best to make sure you are completely satisfied

**Phone / Téléphone :** 1(800) 818-8123**USA:** <https://us.gardena.com/pages/contact-1>**Canada:** <https://www.gardena.com/ca-en/support/advice/contact>

A

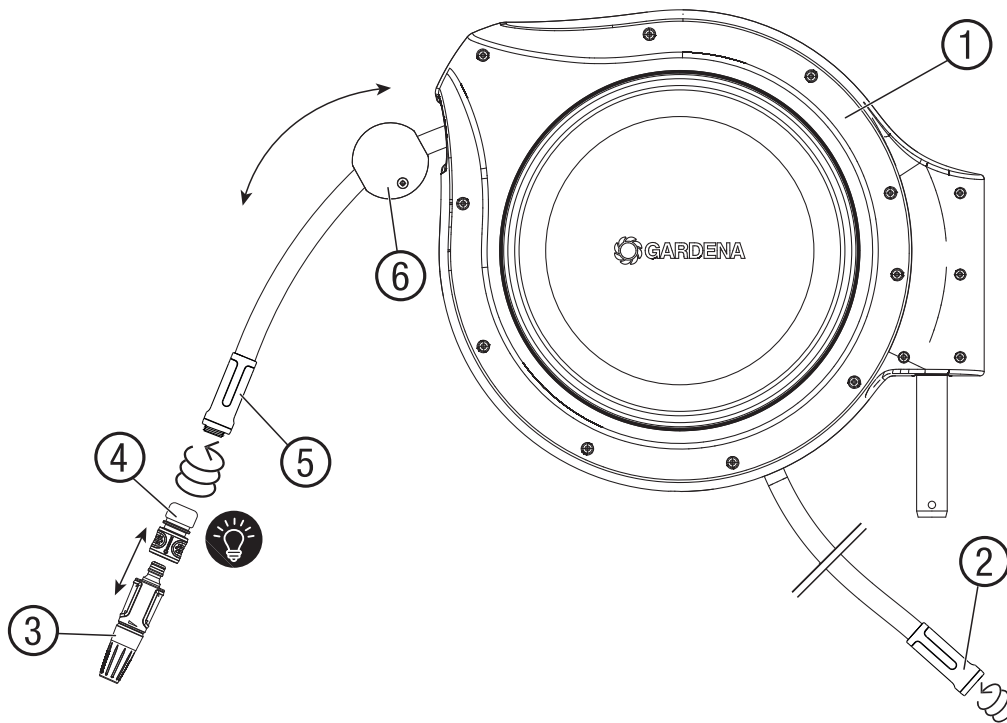

To use the GARDENA quick connect system

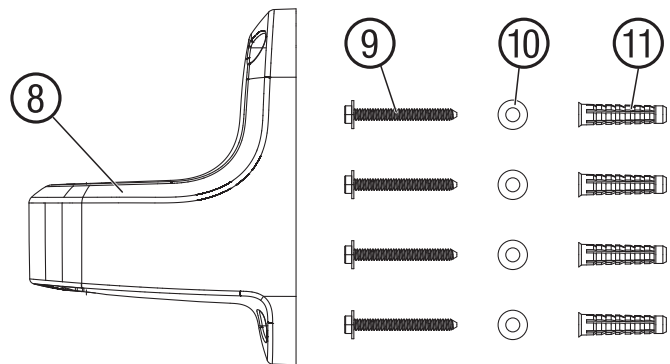
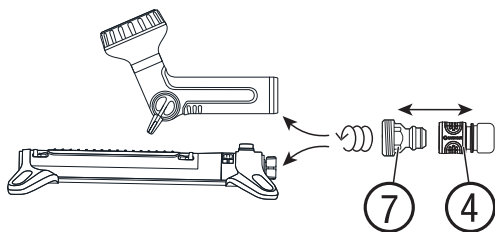

en Product overview

- | | |
|--|---------------------|
| ① Rectable hose reel | ⑦ Accessory Adapter |
| ② Tap connector
(Water input) | ⑧ Wall bracket |
| ③ Nozzle | ⑨ Bolts |
| ④ Accessory End
Quick Connector | ⑩ Washers |
| ⑤ Accessory
end connector
(Water output) | ⑪ Anchors |
| ⑥ Stopper ball | |

B

To mount the wall bracket

B1

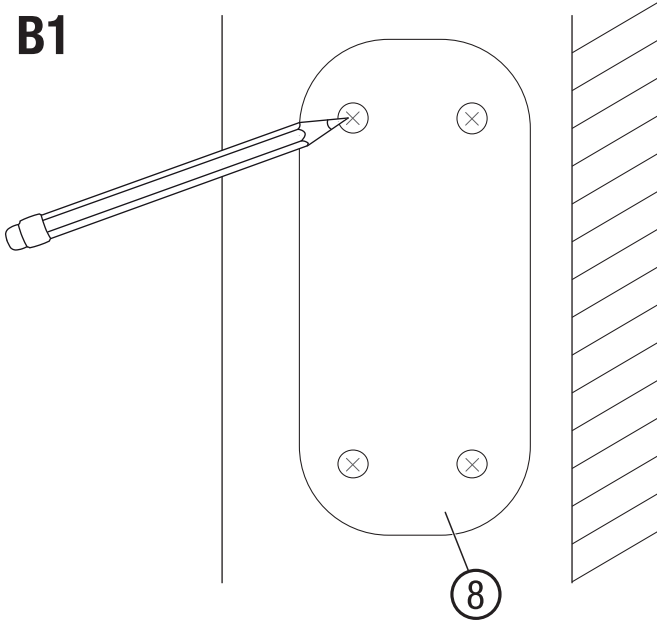

B2

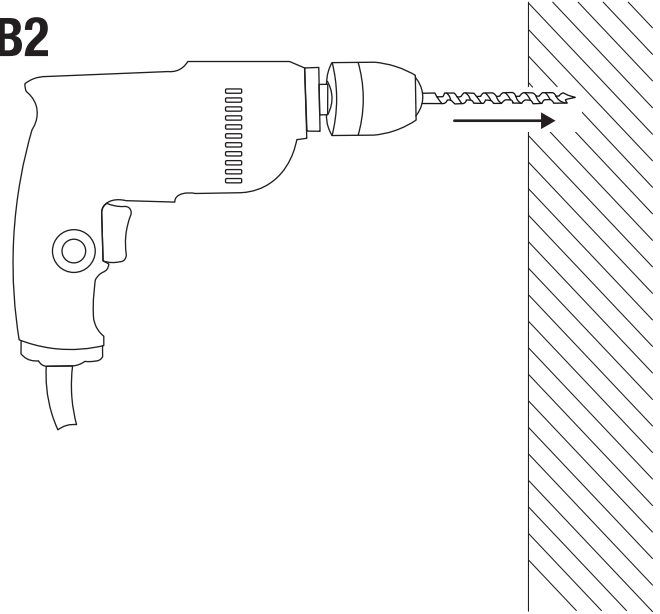

→ Choose a stable and flat wall.

NOTICE!

Bolts should be snug, but do not overtighten. Otherwise the bolts may break.

B3

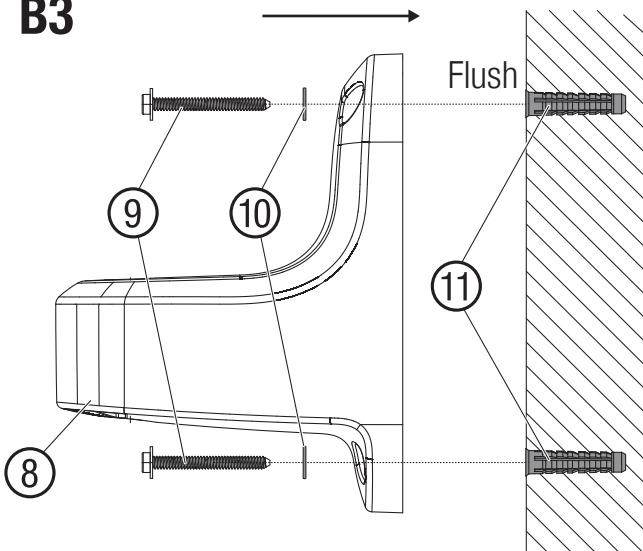

For most installations including wood, stucco, masonry and concrete, use hardware components ⑨, ⑩ and ⑪*.

***For solid wood do not use anchors.**

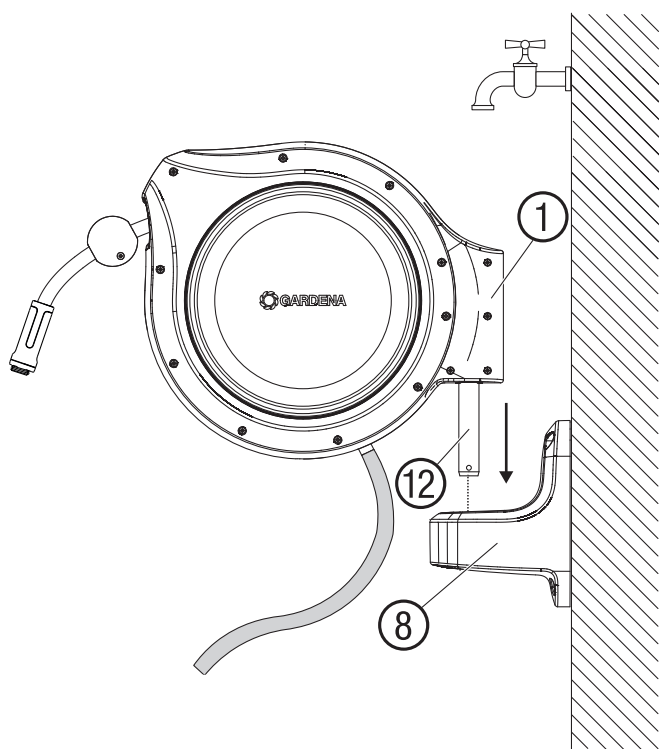
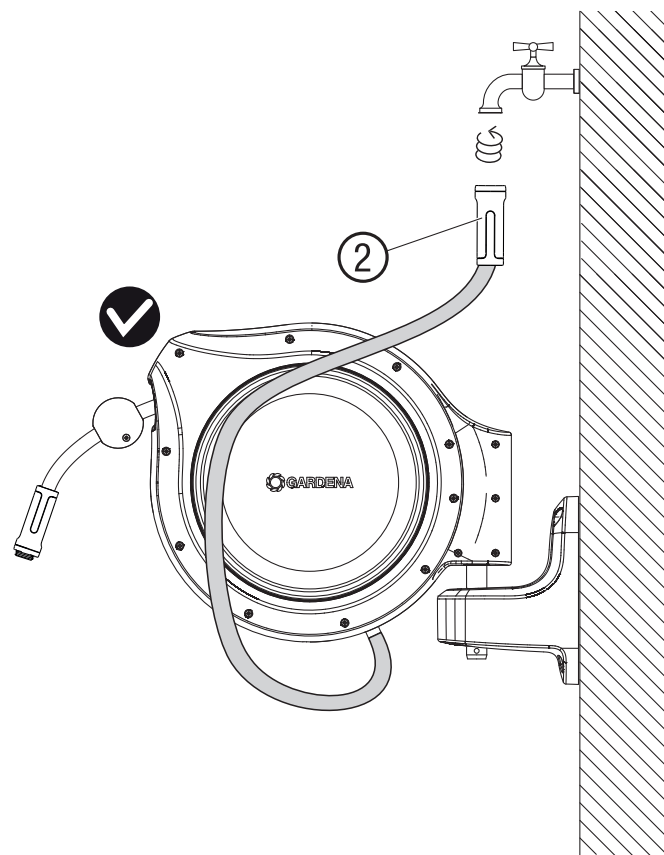
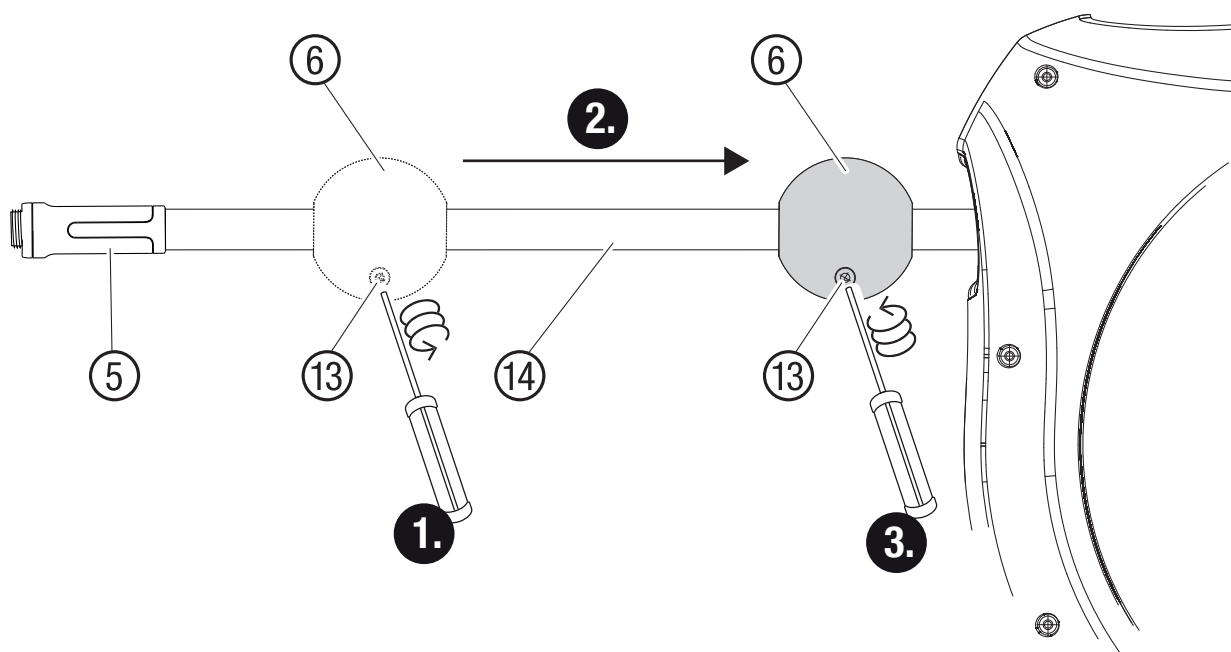
C**To mount the hose reel to the wall bracket****D****To connect the hose to the faucet****E****To shift the stopper**

en Rectable Hose Reel

Original instructions

1. SAFETY WARNINGS 5
2. ASSEMBLY 5
3. OPERATION 6
4. TRANSPORTATION AND STORAGE 6
5. TECHNICAL DATA 6
6. SERVICE / WARRANTY 6
7. DISPOSAL 6

1. SAFETY WARNINGS

1.1 Explanation of the symbols on the product



CAUTION!

→ Read the operating Instructions before initial operation.



DANGER!

Physical injury through prestressed springs.
→ The Hose reel may not be opened.

1.2 Explanation of the safety warnings



CAUTION!

Type and source of hazard.

Indicates a hazardous situation which, if not avoided, could result in minor or moderate injury.

→ Follow the instructions of the safety warning to prevent the threat.



WARNING!

Type and source of hazard.

Indicates a hazardous situation which, if not avoided, could result in death or serious injuries.

→ Follow the instructions of the safety warning to prevent the threat.



DANGER!

Type and source of hazard.

Indicates a hazardous situation that, if not avoided, will result in death or serious injuries.

→ Follow the instructions of the safety warning to prevent the threat.

NOTICE!

Is used to address practices not related to physical injury.

→ Follow the instructions of the safety warning to prevent the threat.

1.3 General safety warnings

- Read the operator's manual carefully before use and keep for future reference.
- Never operate the product when you are tired, ill or under the influence of alcohol, drugs or medicine.
- This product contains springs that are under tension and could result in injury if the product is operated by someone who is: unfamiliar with this product, needs adult supervision, or has impaired judgment due to fatigue, medication, or other substances that can impair judgment or coordination.
- Children must be supervised to ensure that they do not play with the product.
- Never drink the water from the hose.
- Never use hot water with this product.
- Do not place any additional load on the wall bracket.
- Depressurise the hose when not in use.
- Regularly inspect the bracket and securing pins for signs of wear and tear.

1.4 Intended use:

The Hose reel is intended for use with cold water for outdoor irrigation only. This hose is **not** intended to be used as a drinking water hose.

The product is intended exclusively for use in private household gardens or on private allotments.

2. ASSEMBLY



DANGER!

Risk of suffocation.

Small parts can be easily swallowed. Toddlers can suffocate on the polybag.

→ Keep toddlers away when you assemble the product.

2.1 To assemble a watering tool [Fig. A]

You can either assemble a watering tool to the hose with the supplied bonus adapters (see *To use the GARDENA quick connect system*).

Or by drilling the watering tool directly onto the accessory end connector ⑤ of the hose.

As a watering tool, use the supplied nozzle ④ or your individual nozzle or sprinkler.

To use the GARDENA quick connect system:



→ Combine the provided bonus adapters ⑦ (Art. 6924) and the Accessory End Quick Connector ④ (Art. 18218).

1. Drill your watering tool onto the adapters ④ and ⑦.
2. Drill the combination onto the accessory end connector ⑤.

2.2 To choose a mounting location

- Choose a mounting location that is near a water tap **outside**.
- Choose a mounting location that prevents water from entering the building in the event of a leak.
- Choose a mounting location that is protected against direct sunlight so that the product, hose and the water won't overheat.
- Choose a stable and flat wall.
- Check the stability of the wall to ensure it is strong enough to support the weight of the hose reel.

2.3 To mount the wall bracket [Fig. B1, B2, B3]

1. Mark the position of the 4 drill holes with a pencil through the 4 holes of the wall bracket ⑧.
 2. Drill the 4 drill holes into the wall.
 3. Put the anchors ⑩ into the drill holes.
- If mounting to solid wood screw the bolts directly into the wood **without** anchors.
4. Drive the wall bracket ⑧ completely to the wall with the bolts ⑨ and washers ⑩.
 5. Check to make sure the wall bracket is secure and does not wiggle.

2.4 To mount the hose reel to the wall bracket [Fig. C]



CAUTION!

Risk of crushing between product and bracket!

The product can be swivelled 180°. Body parts between hose reel and bracket can be injured.

→ Do not reach between the product and the holder.

1. Pay attention to a secure footing and carry the hose reel as close to your body as possible.
2. Place the hose reel ① with the holding tube ⑫ on the wall bracket ⑧ with both hands.

2.5 To connect the hose to the faucet [Fig. D]

→ Drill the tab connector ② into the faucet.

2.6 To shift the stopper ball [Fig. E]

NOTICE!

Complete pulling in of the watering hose.

Never simultaneously release the accessory end connector ⑤ and the stopper ball ⑥.

- Never let the hose retract without the stopper in place.
- If the hose has been pulled all the way in, please contact GARDENA Service.

1. Loosen the 2 bolts ⑬ on the stopper ball ⑥ with a screwdriver.
2. Hold the watering hose ⑭ securely while shifting.
3. Shift the stopper ball ⑥ and screw tightly again with the 2 bolts ⑬.

3. OPERATION



CAUTION!

Crushing and entanglement hazard due to high spring force.

- Keep your fingers, hair, clothing and all other objects away from the hose and inlet shaft!
- Keep children away from the product.

→ Check the product for damage before retracting and unwinding.

→ Do not use a damaged product.

→ Keep people and animals away from the product while it is in use.

3.1 To unwind the hose

→ Pull out the hose to desired length.

3.2 To retract the hose



CAUTION!

Risk of injury due to uncontrolled hose feed.

- Do not allow the hose to be pulled in without supervision.
- Keep people and animals away from the hose feed.

1. Release the locking device by pulling briefly on the hose.
2. Hold the end of the hose firmly and walk the hose back to the reel with the nozzle ④.

The hose rolls up securely and evenly on its own.

The locking mechanism clicks during unwinding and roll-up.

3.3 About the water stop connector

The accessory end connector ⑤ includes a water stop connector. With no watering tool inserted water cannot flow through the water stop connector.

4. TRANSPORTATION AND STORAGE

NOTICE!

Damage to the product during the frost period.

The hose reel is not frost-proof.

→ Remove the hose reel from the wall in winter to prevent frost damage.

4.1 To transport the product

→ Empty the hose before transporting it.

4.2 To store the product

→ Store the hose reel in a location that is out of the reach of children.

5. TECHNICAL DATA

Hose reel	20505-81
Hose length	100 ft
Weight	31.1 lbs

6. SERVICE / WARRANTY

6.1 Product registration

Please register your product at gardena.com/registration.

Please find the warranty statement online:

<https://us.gardena.com/pages/standard-manufacturers-warranty-policy>

6.2 Service

Please find the current contact information of our service on the back page and online:

- USA: <https://us.gardena.com/pages/contact-1>
- Canada: <https://www.gardena.com/ca-en/support/advice/contact/>

7. DISPOSAL

7.1 Disposal of the product

(In accordance with Directive 2012/19/EU)



The product must not be disposed of to normal household waste. It must be disposed of in line with local environmental regulations.

1. Empty the hose completely before disposing of the hose box.
2. Dispose of the product through or via your local recycling collection centre.

Service contact for Canada / USA

GARDENA Canada Ltd.
125 Edgeware Road
Product 15 A
Brampton L6Y 0P5
ON, Canada
Phone: 1 (800) 818-8123
servicegardena.us@husqvarnagroup.com

20505-81.960.02/1024
© GARDENA Manufacturing GmbH
D-89079 Ulm
<https://www.gardena.com>